

# 2019

## Summary of Major Revisions

to the

### City of Fargo Standard Specifications for Construction

#### SECTION 1300 – WATER MAINS

- 2.1.2: The language that has been used in the Master SIBs was incorporated.
- Deleted 2.5 Butterfly Valves
- 2.3.3: Minimum working pressure of couplings was revised. Approved products were called out.
- 2.11: The tracer wire specifications that had been in the Master SIBs were incorporated.
- 3.10: The pressure and leakage testing language that has been used in the Master SIBs was incorporated.
- 3.11: The bacteriological testing language that has been used in the Master SIBs was incorporated.
- 3.12: The tracer wire system specifications that had been in the Master SIBs were incorporated.
- 4.2.2: Tracer wire and tracer wire accessories shall be included in the price bid for water main.
- 4.2.3: The language and table that were in the Master SIBs for fitting weights has been incorporated.
- 4.2.8: Language was updated to reflect actual practices of tapping of mains and billing.
- Drawings:
  - In general, all details were updated for consistency.
  - Details were also updated to reflect changes to the tracer wire revisions.
  - All trench width details were revised to be OD+24" minimum rather than OD+24" maximum.

#### SECTION 1400 - SEWER AND WATER SERVICE CONNECTIONS

- 2.1.3: PVC saddle wyes are the method for connecting to an existing sewer main. Inserta-tees are allowed only when approved by the Engineer.
- 2.2: The PEX specifications that had been in the Master SIBs were incorporated.

- 2.2.6: Tracer wire access points shall be securely taped to the marker near the curb stop on new construction projects.
- 2.2.7: Tracer wire access points will be required at all curb stop boxes and shall be “SnakePit Lite Duty Access Point” with a blue, single-terminal cast iron lid or approved equal.
- 3.4: Updated to reflect changes necessary for PEX.
- 4.2: Revised to create consistency in bid items between new development and reconstruction projects.
  - To summarize these changes, for services on rehab projects or new development projects the following bid items will be used:
    - Sewer Services: Connect Sewer Service per EA and F&I Pipe per LF
    - Water Services: Connect Water Service per EA, F&I Water Service per LF, F&I CS & Box per EA or Rem & Repl CS & Box per EA
- Drawings:
  - In general, all details were updated for consistency.
  - Details were also updated to reflect changes to the tracer wire and PEX material revisions.
  - All trench width details were revised to be OD+24” minimum rather than OD+24” maximum.



# City of Fargo Standard Specifications for Construction

Revised 2019

*I hereby certify that the attached plan, specification, or report was prepared by me or under my direct supervision and that I am a duly registered Professional Engineer under the laws of the State of North Dakota.*

<u>Brenda E. Derrig /s/</u>	<u>7/30/2019</u>
Brenda E. Derrig, P.E. City Engineer	Date

## SEAL

This document was originally  
issued and sealed by  
Brenda E. Derrig  
Registration Number  
PE-5833  
on 7/30/2019 and the original  
document is stored in the  
Engineering Dept. at City Hall.

# CITY OF FARGO SPECIFICATIONS

<b><u>SECTION NUMBER</u></b>	<b><u>DESCRIPTION</u></b>
1000	EXCAVATION, TRENCHING, AND BACKFILLING FOR UNDERGROUND WORK
1050	REMOVALS
1200	SANITARY SEWERS
1300	WATER MAINS
1400	SEWER AND WATER SERVICE CONNECTIONS
1500	STORM SEWERS
1600	PIPE AND MANHOLE REHABILITATION
2000	EXCAVATION, FILLING, AND SUBGRADE PREPARATION
2050	GEOTEXTILES AND GEOGRIDS
2070	AGGREGATE BASES
2100	CONCRETE PAVING AND CURBS & GUTTERS
2300	CONCRETE SIDEWALKS AND DRIVEWAYS
2400	ASPHALT PAVING
2600	SEAL COATS
2700	GRADING ROADS
2800	GRAVEL SURFACING
2900	PAVEMENT MILLING OR GRINDING
3100	TURF ESTABLISHMENT
3200	SODDING
3300	EROSION AND SEDIMENT CONTROL
3500	BUILDING DEMOLITION
3600	FLOOD CONTROL LEVEES
4000	PAVEMENT MARKINGS
4100	TRAFFIC CONTROL
4200	TRAFFIC SIGNALS
4300	SIGNING
4400	STREET LIGHTING
7000	LANDSCAPING
9000	EXTRA WORK
9900	BIDDING AND CONTRACT DOCUMENTS
(1)	GENERAL INSTRUCTIONS TO BIDDERS
(2)	CERTIFICATE OF INSURANCE
(3)	PROPOSAL
(4)	BIDDER'S BOND
(5)	CONTRACT
(6)	CONTRACT BOND
(7)	LIQUIDATED DAMAGES SCHEDULE

**CITY OF FARGO SPECIFICATIONS  
EXCAVATION, TRENCHING, AND BACKFILLING  
FOR UNDERGROUND WORK**

**PART 1  
DESCRIPTION OF WORK**

The terms “Excavation” and “Trenching”, either individually or collectively, as used in these Specifications and other contract documents shall refer to and shall mean all material excavated or otherwise removed, in the performance of the specified work and all subsequent handling, backfilling, and/or disposing of such material. Excavation and trenching shall include site clearing and preparation where required, subgrade preparation, boring, tunneling, bell holes, all sheeting, shoring, and dewatering of trenches and excavations, protection of adjacent property, backfilling, pipe encasement, specified backfill compaction and consolidation, surfacing, final grading and dressing of the sites to the grades and elevations shown on the drawings or specified to be done, and other work necessary or required.

**PART 2**  
**MATERIAL**

2.1. CLASSIFICATION OF EXCAVATED MATERIAL

No classification of excavated material will be made. Excavation and trenching work shall include all the removal and subsequent handling of all material encountered in the excavation limits.

2.2. SURFACE RESTORATION

Unless stated specifically to the contrary in the Special Instructions, the Contractor shall replace all surface material and shall restore paving, curbing, sidewalks, gutters, fences, sod, topsoil, and other items disturbed, to a condition equal to that before the work began; furnishing all labor, material, and equipment necessary to do this work. Traveled streets shall be kept open and maintained by the Contractor after the backfilling and before surfacing or final inspection. The cost of all such work shall be absorbed in the contract unit price for size of pipe being installed unless otherwise specified in the special instructions.

2.3. BARRICADES AND LIGHTS

When streets or public thoroughfares are impacted by construction activity, the public shall be protected by placement of adequate warning devices. All open trenches and other excavations shall be provided with suitable barrier signs and lights, to the extent that adequate protection is provided to the public against accident by reason of such open construction. Obstructions such as equipment and material piles shall be provided with similar warning signs and lights.

All barricades and warning devices shall be in accordance with Section 4100 of these Specifications.

2.4. PAVING REMOVAL AND REPLACEMENT

Whenever paving or sidewalk is encountered on the line of the pipe, it shall be cut through at such places and in such a manner as the Engineer may direct. Removals shall be in accordance with Section 1050 of these Specifications.

The Contractor shall maintain all paving cuts until paving is done. Temporary patching may be done with concrete, asphalt, stabilized gravel or any other method approved by the Engineer, except for temporary patches left over the winter, which shall be concrete. Permanent patches shall be subject to the warranty period specified in the contract.

A. ASPHALT PAVING

Asphalt paving that is removed shall be replaced in kind in accordance with Section 2400 of these Specifications.

B. CONCRETE PAVEMENT REPLACEMENT

Concrete pavement and concrete base pavement that is removed shall be replaced in kind in accordance with Section 2100 of these Specifications.

C. SIDEWALK REPLACEMENT

Concrete sidewalks removed on the line of the pipe shall be replaced in kind with new sidewalk. Sidewalk replacement shall be done in accordance with Section 2300 of these Specifications.

2.5. TRENCH FOUNDATION MATERIAL

Material used for stabilizing trench bottoms shall be 100% crushed rock and shall be sized 1-1/4" minus or as specified on the plans or bid sheet.

**PART 3**  
**CONSTRUCTION**

3.1. LOCATION AND PROTECTION OF EXISTING UTILITIES

The location of the public or private utilities may be shown on the plans, as reported by the various utility companies and the City, but this does not relieve the Contractor of the responsibility of determining the accuracy or completeness of said locations. North Dakota law requires the Contractor to contact ND One-Call at 800-795-0555 prior to any underground interference. The Contractor shall protect all trees, shrubs, manholes, water shut-off, survey monuments, or any other existing utilities from damage. Any utilities that are damaged during the course of the work shall be repaired or replaced to the satisfaction of the Engineer at the Contractor's expense.

3.2. CONTRACTOR TO MAINTAIN TRAFFIC AND DRAINAGE

A. *TRAFFIC*

The Contractor shall conduct the work in such a manner as to interfere as little as possible with the use of the street for public travel, whether vehicular or pedestrian. When it is necessary to cross or interfere with roads, driveways, and walks, whether public or private, the Contractor shall at his own expense provide and maintain suitable and safe bridges, detours, or other temporary expedients for the accommodation of travel, and shall give reasonable notice to owners of private drives before interfering with them; provided however, that such maintenance of traffic will not be required at any point where the Contractor has obtained permission from the owner and tenant of the private property, or from the authority having jurisdiction over public property involved to obstruct traffic at any designated point thereon and for the duration of whatever period of time as may be agreed on.

B. *DRAINAGE*

The trenches shall be smoothed to conform to the elevations and contours of the existing ground and all sod removed or damaged shall be replaced at the Contractor's expense. The backfilling of the trench shall be done in such manner as to prevent water from accumulating in unfilled or partially filled trenches. All ditches or other watercourses crossed by the line of the trench shall be restored to their original condition immediately

after backfilling in order that surface drainage will be obstructed no longer than necessary.

### 3.3. CLEARING, GRUBBING, AND TREE REMOVAL

Sites that are to be occupied by permanent construction or which are to be excavated and graded shall be cleared and grubbed of all stumps, trees, logs, brush and other vegetation and debris as may be required for the proper conduct and execution of the work.

Clearing, grubbing, and tree removal shall be in accordance with Section 1050 of these Specifications.

### 3.4. TOPSOIL

#### *3.4.1. STRIPPING AND STOCKPILING*

The Contractor shall remove and stockpile all topsoil in areas of excavation as delineated in the field by the Engineer in accordance with Section 1050 of these Specifications.

#### *3.4.2. TOPSOIL SPREADING AND IMPORT*

All topsoil shall meet the requirements specified in Section 2000 of these Specifications.

### 3.5. DISPOSAL OF EXCESS MATERIAL

All excess excavated material shall become the property of the Contractor and shall be disposed of away from the work site at such locations and in such a manner as the Engineer may direct. The Contractor shall furnish a dump person at no expense to the City. Broken concrete, asphalt, and other similar materials shall be separated from the earth fill and hauled to the City of Fargo landfill.

Stockpiling: On projects where the City retains ownership of the excess material at a site designated on the plans or special instructions, the Contractor shall stockpile the material. The costs to haul and shape the material to a drainable, mowable stockpile shall be included in the cost of other bid items.

### 3.6. EXCAVATION FOR STRUCTURES

Except where special construction on unstable soil is authorized, all structures shall be founded on and be in direct contact with undisturbed original subsoil; all unauthorized excavation below the specified structure subgrade shall be replaced by and at the expense of the Contractor, with concrete monolithic with that of the structure, slab or foundation above.

All excavations shall be kept dry to the extent that no pipe or reinforcing steel is installed in water and that no water will be allowed to rise over the reinforcing steel prior to the concrete being placed. No water shall be allowed to come in contact with any concrete within 12 hours after placing. Such lowering of the water level shall be maintained from subgrade preparation until after the concrete has been placed and hardened. In the case of trenches, the dewatering shall be done by means of well points or other acceptable means until the pipe has been laid and backfill has been completed to a stage where danger from flotation is eliminated.

The Contractor is responsible for the condition of any sewer, drain or other conduit which may be for drainage purposes and all such pipes or conduits shall be clean and free of all sediment before acceptance thereof by the Engineer.

Concrete forms shall be required above extended footings and excavations shall provide adequate clearance for their installation and removal. In no case shall excavation faces be undercut to provide for extended footings. Not less than 6 inches clearance shall be provided between excavation faces and brick or block masonry exterior wall surfaces that are to be plastered.

Subgrade soil for all concrete structures shall be firm, dense, and thoroughly consolidated and compacted; shall be free of mud and muck; and shall be sufficiently stable to remain firm and intact under the feet of the workmen. Where necessary, a layer of concrete of sufficient strength and thickness to withstand subsequent construction activity shall be installed below the specified subgrade elevation and the structure concrete placed thereon. Coarse gravel or crushed stone may be used for subsoil reinforcement if satisfactory results can be obtained thereby. Such material shall be applied in thin layers, each layer being entirely embedded in the subsoil by thorough tamping. All excess soil shall be removed to compensate for the displacement of the gravel or crushed stone and the finished elevation of any subsoil reinforced in this manner shall not be above the specified subgrade.



### 3.7. STRUCTURE BACKFILL

Backfilling around and outside of structures shall be adequately compacted, to the extent necessary to prevent future settlement, by tamping or by other means approved by the Engineer. Settlement by inundation with water will be permitted only where no damage could result to the structure from hydrostatic pressure or uplift. All backfill shall be earth only, with no vegetation or debris being placed in the backfill.

Mechanically compacted backfill shall not be deposited or compacted in water and shall consist of loose, damp earth having a moisture content such that maximum density of the compacted soil will be obtained. Moisture content shall be uniform throughout and where added, it shall be made in sufficient time in advance to ensure uniform distribution throughout the backfill.

### 3.8. TRENCH EXCAVATION

No more than 300 feet of trench shall be open at any one time in advance of the complete construction of the pipe installation. Ordinary excavation shall be open-cut from surface, however when depth of trench and soil conditions permit, tunneling may be required beneath crosswalks, driveways, curbs and gutters, pavement and other surface structures; for such tunneling no additional compensation will be allowed over the price for open-cut excavation.

All material excavated shall be deposited alongside the trench in a manner that will cause the least inconvenience to the public and be consistent with the rapid and economical handling of the work. Sidewalks, streets, driveways, and alleys shall be kept open to traffic and all trees shall be protected from injury.

#### *3.8.1. ROUGH EXCAVATION*

Rough excavation shall be deep enough to provide at least three (3) inches of pipe embedment material as specified. Trenches shall be of sufficient width to provide ample space for workmen to install the pipe and in no case shall the trench be less than 24 inches.

### 3.8.2. *HAND EXCAVATION*

Hand excavating tools and methods shall be used in locations where the use of mechanical equipment would cause damage to trees, buildings, culverts, utilities, or other structures above or below ground.

### 3.8.3. *TUNNEL EXCAVATION*

Tunnel sections shall provide adequate clearance for the proper installation of the pipe. All bracing, shoring, or sheeting necessary for the construction of the tunnel and the proper protection of the workmen therein shall be furnished and installed by the Contractor and, where and as required by the Engineer, shall be left in place. All tunnel backfill shall be of proper moisture content and condition to readily compact, and shall be thoroughly tamped and rammed into the annular space around the pipe.

### 3.8.4. *ALIGNMENT, GRADE, AND MINIMUM COVER*

The alignment, grade and elevation shall be fixed and determined by means of offset stakes located by the Engineer. The minimum cover over water lines and the minimum separation from sewer lines shall be in accordance with Section 1300 of these Specifications. Care should be taken to maintain depth of cover under ditches, vertical curves, gutters and on service lines. Cover over sewers and sewage force mains shall be as shown on the plans and as staked by the Engineer.

### 3.8.5. *REPLACEMENT OF UNSUITABLE PIPE FOUNDATION MATERIAL*

When, in the sole opinion of the Engineer, the trench bottom is not suitable to provide a uniform base for the pipe, the trench shall be undercut to sufficient depth to build an acceptable base.

### 3.8.6. *ARTIFICIAL TRENCH FOUNDATIONS*

Whenever so ordered by the Engineer, the Contractor shall excavate to such depth below grade as the Engineer may direct and the trench bottom shall be brought to grade with such artificial material(s) as the Engineer may order installed. All timber, concrete foundations, wooden invert, pipes, posts, stringers, and/or saddles made necessary by quicksand or other treacherous soil, shall be installed as directed by the Engineer.

### 3.8.7. DEWATERING OF TRENCHES

Pipe trenches shall be kept free from water during excavation, grading, pipe laying and embedment in an acceptable manner. When the trench bottom is unstable due to ground water, and in all cases where the static ground water level is above the bottom of the trench or bell hole excavation, such ground water shall be lowered by means of well points and pumps or by other means acceptable to the Engineer, to the extent necessary to keep the trench free from water and the trench bottom stable at all times the work is in progress. The disposal of the wastewater from trench dewatering operations shall be piped/routed to existing drainage ditches, channels or drains, subject to the approval of the Engineer. Surface water shall be diverted to prevent it from entering trenches to the greatest extent possible without damage to adjacent property from dikes, ditches, or impounded water. The ND Storm Water Permit shall govern dewatering methods.

### 3.8.8. FINISH GRADING OF TRENCH BOTTOM

Trench bottoms shall conform to the grade and elevation to which the pipe is to be laid and the gravel bedding shall be accurately compacted, graded, and shaped to provide uniform bearing and support for each pipe along its length between bell holes before the pipe is laid in the trench.

In the event that after placing the pipe in the trench it is found that the prepared trench bottom is not at the proper elevation, the pipe shall be removed and the grade corrected. In no case shall the pipe be raised from and dropped in the trench bottom for the purpose of lowering a subgrade that is too high.

#### A. BELL HOLES

Bell holes in the trench bottom shall be dug after the trench has been graded. Each bell hole shall be dug immediately prior to placing the pipe in the trench. Regardless of the type of joint, all bell holes shall be of sufficient depth and size that the joints can be properly made with no part of the pipe bell in contact with the trench bottom.

#### A.1. SANITARY AND STORM SEWERS

Bell holes shall not be longer than 1/4 of the pipe laying length nor exceed 18 inches.

#### A.2. WATER LINES

Bell holes shall be large enough to properly make the joint, and no part of the pipe bell is in contact with the pipe bottom.

#### B. EXCAVATION FOR CONCRETE ENCASEMENT OR EMBEDMENT OF THE PIPE

Where concrete encasement or embedment is required, trench subgrade elevation will be determined by the thickness of the required concrete section. The horizontal dimension shall be at least the minimum trench width permitted for the pipe being laid and shall extend the full width of the trench as excavated and shall be poured against vertical trench walls. In the case of a sheeted trench, the concrete shall be poured against sheeting that has been left in the trench.

#### 3.8.9. MAXIMUM TRENCH WIDTHS

Trenches shall be excavated to a width that will provide adequate working space to install and embed the pipe. However, in order to protect the pipe from loading in excess of design conditions, the width of the lower portion of the trench to a point 6 inches above the pipe shall not exceed 24" plus the outside diameter of the bell.

#### 3.8.10. UNAUTHORIZED TRENCH WIDTHS

Where, for any reason, the width of the lower portion of the trench exceeds the maximum permitted, pipe of adequate design, special pipe embedment, rock encasement, or arch concrete encasement as required by loading conditions and as determined by the Engineer shall be furnished and installed by the Contractor at his sole expense. The determination of necessary pipe, special embedment or arch concrete encasement shall be based on pipe strength equal to the minimum three-edge bearing ultimate strength stipulated in the governing pipe specification for the size and type of pipe involved. Trench loading will be based on saturated backfill weighing 120 pounds per cubic foot with suitable allowances for trench or other live loads where required.

*3.8.11. TRENCH BRACING AND SHEETING*

Sheeting, bracing, or pulling a trench box or shield shall be used and maintained where necessary to comply with City, County, State and Federal regulations to protect personnel & property on the job. The cost of such sheeting, unless a special price is called for in the contract, shall be included in the bid price per foot of pipe. In order to meet trench width provisions, it is not possible for the trench box or shield to be on grade at the bottom of the pipe. The box shall be made to rest on a ledge cut along each side of the top of the pipe, and a narrower and deeper trench shall be cut inside the box to accommodate the bedding material, pipe, and backfill material up to the top of the pipe. This installation is necessary to maintain the strength of the flexible pipe and pipe envelope and to prevent excessive deflection when the box is moved forward and the pipe trench is backfilled.

In the event it is necessary to extend sheeting or bracing to the bottom of the trench, all materials used therein, except cross braces that interfere with the pipe installation, shall be left in place. Where sheeting is left in place, it shall not be braced against the pipe, but shall be supported by stakes driven into the trench bottom on each side of the pipe and with tops of the stakes supported by cross braces above the top of the pipe or by other means, approved by the Engineer, which will not result in the application of concentrated loads or horizontal thrust on the pipe. These cross braces may be removed after the specified pipe encasement has been completed beyond the point of cross brace removal.

*3.8.12. SHEETING LEFT IN TRENCH*

The Contractor may make written request to the Engineer for permission to leave timber in a trench and receive payment for the same. Such request must state location, the amount of timber, and the reason for leaving it in the trench. When such request is made and granted, payment shall be made only for the timber left in the trench at current prices in the City of Fargo. No timber shall be left in the trench without written order of the Engineer.

*3.8.13. DISPOSAL OF EXCESS EXCAVATED MATERIAL*

All excess material removed from trenches shall be disposed of at such location and in such manner as the Engineer may direct. Any material loaded, hauled, and dumped within a two (2) mile radius of the project shall be done by and at the expense of the Contractor. The Contractor shall level the dumpsite to the satisfaction of the Engineer.

*3.9. HAUNCHING, ENCASEMENT, AND TRENCH BACKFILL*

The bedding material shall be placed so that after the pipe is laid, the bedding will extend up the sides of the pipe a distance of 1/2 the pipe diameter, where the material shall then be shovel-sliced and tamped with mechanical tamping equipment to provide uniform bearing along the entire length of pipe.

Generally, most of the trenches backfilled in the City of Fargo will be backfilled with the excavated material, however in certain cases, special types of backfill will be used. No trench backfill containing rock or detritus from rock excavation shall be placed in the upper 12 inches of the trench nor shall any rock, stone, concrete or boulder larger than 8 inches be placed within 6 inches of any portion of installed pipe. Large stones or concrete pieces may be placed in the remainder of the trench backfill only if well separated and so arranged that no interference with backfill settlement will result.

*3.9.1. TYPES OF BACKFILL AND ENCASEMENT MATERIAL**A. COMPACTED EARTH BACKFILL*

Compacted earth backfill shall be free from sticks, large roots, or other organic material coarser than grass roots, stones, hard lumps, and clods and shall have a moisture content such that optimum compaction is obtained when PROPERLY TAMPED OR ROLLED.

*B. UNCOMPACTED OR WATER SETTLED EARTH*

All earth backfill not required to be tamped or rolled, including all earth backfill settled with water, shall be free of brush, roots more than 2 inches in diameter, or other organic material that would interfere with proper settlement and consolidation.

## C. GRAVEL OR SAND BACKFILL

Gravel for backfill shall meet the requirements for ND Class 3 with the Number 200 sieve requirement modified to be 3-15% passing. When the aggregate does not meet the gradation specified for all required samples, a reduction in the contract unit price will be made for such material in accordance with the acceptance requirements for Aggregate Base outlined in the current version of the NDDOT Standard Specifications for Road and Bridge Construction.

## D. PIPE ENCASEMENT

All gravel for pipe encasement shall meet the requirements specified above.

## E. CONCRETE ENCASEMENT

All concrete for encasement shall be 3000 psi Portland Cement Concrete.

3.9.2. *PIPE ENCASEMENT METHODS*

## A. GRAVEL ENCASEMENT AND HAUNCHING

The pipe shall be bedded and encased in gravel encasement as specified. After the pipe has been graded, aligned and joined, sufficient gravel encasement material shall be deposited and compacted under and around each pipe in 6" lifts with mechanical tamping equipment to firmly support and hold the pipe in position during subsequent pipe laying activity. Gravel encasement material shall be deposited in such a manner that it is scattered along the pipe and not dropped in a compact mass.

All pipe and bells shall be covered with a minimum of 3 inches of gravel above the pipe. The gravel shall not be "humped" over the pipe but shall be level from one side of the trench to the other.

For concrete storm sewers, gravel encasement shall only be required to 1/2 way up on the pipe. PVC and PP storm sewer shall be covered with a minimum of 3" of gravel above the pipe.

**B. CONCRETE ENCASEMENT**

The pipe shall be encased in concrete when called out on the plans or as determined by the Engineer. Materials shall be as specified and constructed as directed by the Engineer.

Loose material shall be removed from the trench and the concrete placed with continuous contact with undisturbed soil on the sides and bottom of the trench. A base course of concrete shall be screeded to a level that ensures the pipe to be at the specified grade. Each length of pipe shall be held in rigid alignment and braced to prevent flotation. The pipe joints shall be carefully sealed to prevent entrance of concrete mortar and water into the joints. The cementing or sealing of the joints shall be done at least one hour before the encasement is poured.

**3.9.3. BACKFILLING ABOVE PIPE ENCASEMENTS**

Normal backfill above pipe encasement shall be done with excavated earth backfill and compacted. Compacted gravel backfill above encasement for the entire depth of the trench will be required beneath pavements, driveways, parking areas, curbs, gutters, walks or other surface construction; road and highway shoulders; and all tunnel backfill, except where a clay capped trench is required (see standard details).

The locations of compaction tests will be determined by the Engineer in the field. The Contractor shall assist with, and make all necessary accommodations for compaction and material testing at no additional compensation.

**3.9.4. COMPACTION METHODS****A. STANDARD COMPACTION OF BACKFILL**

The backfill shall be compacted to 90% of Standard Proctor Density for areas outside the street right-of-way and 95% of Standard Proctor Density for all trenches located in street right-of-ways unless otherwise noted on the plans or special instructions. Moisture content shall be between optimum and +6% of optimum for earth backfill and between 4% of dry weight and optimum for gravel backfill. Where excessive ground moisture is encountered, the Engineer



may relax the earth backfill moisture requirements, in which case the Contractor shall provide compactive effort satisfactory to the Engineer to achieve compaction as close to zero-air voids as possible.

Before any compaction is begun, two (2) feet of backfill shall be placed over the encasement to prevent damage to the installed pipe. Backfill shall be compacted in successive 12-inch layers. If pneumatic hand tampers are used, the backfill shall be installed in 6-inch layers. Pneumatic tampers are to be used only in areas that are not accessible to heavier duty or motorized compaction equipment. The Contractor shall take special care to uniformly compact all portions of the trench, particularly the valve boxes and manholes, as he is responsible for damage caused by future settlement due to improper compaction.

**B. WATER SETTLEMENT OF BACKFILL**

Earth, gravel and sand backfill may be compacted by the water settlement or “flushing” method where permitted by the special instructions or by the Engineer and where water and fire hydrants are available. Water shall be applied in a manner that will use a minimum of water yet provide effective settlement of the backfill. In no case shall the trench be allowed to overflow or water to be wasted. Generally, the water shall be introduced into the bottom of the trench as quickly as possible by forcing the hose vertically downward in the trench and regulating the flow to promote consolidation.

**3.10. FINAL INSPECTION**

After the Contractor has completed the installation of the public facility and any clean-up items, he shall make a written request to the Engineer for a final inspection. Upon receipt of this request, the Engineer will set a date and time for the final inspection. The final inspection request form can be found on the City’s website.

**PART 4**  
**GUARANTEE, MEASUREMENT & PAYMENT**

4.1. GUARANTEE

The guarantee shall be per the contract, and shall include trench settlement. When settlement occurs during the guarantee period, the Contractor shall fill the settled area with imported topsoil and reseed, or repair settled curb, pavement, etc. as applicable, at no additional cost to the City.

4.2. MEASUREMENT AND PAYMENT

*4.2.1. EXCAVATION AND BACKFILL FOR STRUCTURES*

All costs for excavating and backfilling of structures shall be included in the cost of the structure unless indicated as a separate bid item on the bid sheet. Where gravel is indicated as a separate bid item on the bid sheet, it will be measured and paid for on a cubic yard basis.

*4.2.2. TRENCHING*

The cost of trenching and subsequent handling of the material regardless of character or condition shall be included in the contract unit price for the pipe per linear foot in place.

*4.2.3. TRENCH FOUNDATION MATERIAL*

The contract unit price for “Trench Found” for the size of pipe being installed shall include all costs for removal of unsuitable material and replacement with material meeting the specifications for Foundation Material.

Where no bid item exists, the Contractor will be paid the actual cost of the delivered foundation material plus 15%, with no allowance for excavation nor the installation of the material.

#### 4.2.4. ARTIFICIAL TRENCH FOUNDATIONS

Where not otherwise provided for in the special instructions or on the bid sheet, compensation for extra excavation and artificial trench foundations shall be made in accordance with Section 9000 of these Specifications.

#### 4.2.5. BACKFILL

Backfilling of trenches will be paid as follows:

- A. STANDARD COMPACTION OF BACKFILL: All costs for standard compaction of backfill shall be included in the contract unit price for the size of pipe being installed.
- B. GRAVEL BACKFILL: All costs for installing and compacting gravel backfill shall be included in the “w/Gravel Backfill” contract unit price for the size of pipe being installed. The contract unit price shall include the cost of loading, hauling, and dumping of the excavated material.

In the event no “w/Gravel Backfill” bid item is provided on the bid sheet for the size of pipe being installed with gravel backfill, gravel backfill will be paid for by the cubic yard as an extra to the contract. The Contractor will be paid the actual cost of the gravel backfill material plus 15% with no allowance for the installation. The cubic yards of gravel will be calculated by multiplying the length of the trench by the height as measured from the top of the pipe encasement to the bottom of the existing pavement (or top of gravel if not under hard surfacing). This product will then be multiplied times the average width; however the width shall not exceed the outside diameter of the pipe bell plus 24 inches at the bottom of the trench and 48 inches plus the outside diameter of the pipe at the top.

- C. WATER SETTLED BACKFILL: All costs for this type of backfilling shall be included in the contract unit price for the size of pipe being installed.

#### 4.2.6. GRAVEL ENCASEMENT

All costs of furnishing and placing the gravel encasement shall be included in the contract unit price for the size of pipe being installed.

#### 4.2.7. CONCRETE ENCASEMENT OF PIPE

If concrete encasement is shown on the plans and not included as a separate item on the bid sheet, its cost shall be included in the contract unit price for the size of pipe being installed. In cases where unforeseen conditions warrant the use of concrete encasement and such has not been included on the plans or bid sheet, it will be paid for in accordance with Section 9000 of these Specifications.

#### 4.2.8. PAVEMENT AND SIDEWALK REMOVAL AND REPLACEMENT

If pavement or sidewalk removal is shown on the plans and not included as a separate item on the bid sheet, its cost shall be included in the contract unit price for the size of pipe being installed. In cases where a separate bid item exists for pavement or sidewalk removal and replacement, the maximum width of concrete or asphalt pavement that will be paid for is 48 inches plus the outside diameter of the pipe bell. Any removal in excess of these limits will be at the expense of the Contractor unless the Engineer designates additional removal.

#### 4.2.9. TREE REMOVAL

Tree removal shall be in accordance with Section 1050 of these Specifications.

#### 4.2.10. CLEARING AND GRUBBING

Clearing and Grubbing shall be in accordance with Section 1050 of these Specifications.

4.2.11. *TOPSOIL*

Topsoil will be paid as follows:

A. TOPSOIL STRIPPING:

Topsoil stripping shall be in accordance with Section 1050 of these Specifications.

B. TOPSOIL SPREADING:

Topsoil spreading shall be in accordance with Section 2000 of these Specifications.

C. TOPSOIL IMPORT:

Topsoil import shall be in accordance with Section 2000 of these Specifications.

**CITY OF FARGO SPECIFICATIONS  
REMOVALS**

**PART 1  
DESCRIPTION OF WORK**

The work to be done under this section of the Specifications and the accompanying plans consists of all labor, material, and equipment necessary to perform vegetation removal, topsoil stripping, abandonment or removal and disposal of designated in-place infrastructure, and such other work and incidentals as may be necessary to properly complete the work.

**PART 2**  
**MATERIAL**

2.1. OWNERSHIP AND DISPOSAL OF REMOVED MATERIALS

Removed materials shall become the property of the Contractor unless otherwise indicated, except for flap gates, sluice gates, manhole/inlet castings, valves, and hydrants, which shall be salvaged and delivered to City Personnel at the City of Fargo cold storage site at 2401 5th Avenue North, unless otherwise directed by the Engineer.

Disposal of all removed materials shall be in accordance with all applicable federal, state or local regulations.

**PART 3**  
**CONSTRUCTION**

3.1. LOCATION AND PROTECTION OF EXISTING UTILITIES

The location of the public or private utilities may be shown on the plans, as reported by the various utility companies and the City, but this does not relieve the contractor of the responsibility of determining the accuracy or completeness of said locations. North Dakota law requires the contractor to contact ND One-Call at 800-795-0555 prior to any underground interference. The contractor shall protect all trees, shrubs, manholes, water shut-off, survey monuments, or any other existing utilities from damage. Any utilities that are damaged during the course of the work shall be repaired or replaced to the satisfaction of the engineer at the contractor's expense.

3.2. CLEARING AND GRUBBING

Prior to topsoil stripping, all topsoil shall be made to be free from surface vegetation over six inches in height, trash, stones, and all other debris by clearing and grubbing. The Engineer will establish the limits for clearing and grubbing and designate all trees, shrubs, plants and other items that are to be removed. Unless otherwise specified, all material cleared and grubbed shall be disposed of at the City of Fargo landfill.

3.3. TREE REMOVAL

The Engineer will mark all trees that are to be removed; the Contractor shall not remove any tree not marked for removal. The Contractor shall take all appropriate precautions to protect trees that are not marked for removal. All tree removals shall include pulling from the ground and removing the root ball (stump) of all removed trees. In no case will grinding of the root ball be allowed.

3.4. TOPSOIL STRIPPING

Where topsoil stripping requirements are not outlined in the Special Instructions, the entire thickness of existing topsoil shall be stripped. Topsoil that is temporarily stockpiled for respreading on the project shall be piled within the construction limits delineated by the Engineer. Where the plans or Special Instructions call for permanent stockpiling of topsoil, the costs to haul and shape the material to a drainable, mowable stockpile shall be included in the contract price for topsoil stripping.



3.5. REMOVAL OF UNDERGROUND UTILITIES*3.5.1. REMOVAL OR ABANDONMENT OF PIPE*

Existing pipe shall be removed or abandoned where so designated on the plans or as directed by the Engineer. When existing pipe is encountered which is not shown on the plans, it shall not be removed or abandoned until the Engineer has been notified of its presence and has directed its removal or abandonment.

All ends of pipe on live sanitary sewers and water mains shall be sealed to a watertight condition with a slip-on or mechanical plug manufactured for the size and type of pipe being plugged. Other pipes may be plugged with low-slump concrete in accordance with the standard detail for concrete pipe plugs.

*3.5.2. ASBESTOS-CEMENT PIPE (ACP) SPECIAL REQUIREMENTS*

Removal, disposal, alteration, modification or abandonment of existing ACP shall meet the requirements of the current publication entitled “AWWA Work Practices for Asbestos-Cement Pipe” or subsequent revisions and in accordance with the requirements provided in the current standard entitled “OSHA Asbestos Construction Standards” or subsequent revisions for the removal, disposal, or abandonment of all ACP as shown on the plans and/or encountered in the field during construction, and any other applicable federal, state or local regulation.

Cutting: Keep the pipe wet at all times. A pipe-cutter shall be used – sawing the pipe will not be allowed.

Coupling Removal: Keep the pipe wet at all times. AC coupling removal may be accomplished by gradually splitting the coupling lengthwise using a chisel and hammer. After the top of the coupling has been split, a crowbar or similar tool is used as a lever to split the bottom of the coupling.

Cleaning: Vacuum dust and/or cuttings with a HEPA rated vacuum cleaner. DO NOT blow out with compressed air, dry sweep, or vacuum with a non-HEPA rated vacuum cleaner.

Rasping: Keep the pipe wet at all times. Field-cut ends and/or holes made in the pipe by using a hammer and chisel may be dressed or beveled using a coarse wood rasp. All dust and cuttings shall be removed from the pipe’s interior

by flushing with water, wet mopping, or vacuuming with a HEPA rated vacuum cleaner.

**Handling:** Care shall be taken to prevent the breakup of the pipe material by rough handling or dropping of the pipe. All removed ACP shall be disposed of at the City of Fargo Landfill or other approved disposal site.

**Wet Tapping:** Keep the pipe wet at all times. Downstream flushing shall be performed or tapping equipment shall be used that provide positive purge or “blow-off” features.

**Dry Tapping:** Keep the pipe wet at all times. All dust and cuttings shall be removed from the pipe’s interior by flushing with water, wet mopping, or vacuuming with a HEPA rated vacuum cleaner.

### *3.5.3. REMOVAL OR ABANDONMENT OF MANHOLES/INLETS*

Existing manholes and/or inlets shall be removed or abandoned where so designated on the plans or as directed by the Engineer. When an existing manhole/inlet is encountered which is not shown on the plans, it shall not be removed or abandoned until the Engineer has been notified of its presence and has directed its removal or abandonment.

Manholes/inlets to be abandoned shall have the pipe leads plugged from within the manhole with two feet of low-slump concrete, the top section shall be removed, then the manhole/inlet shall be filled and compacted with ND Class 3 – modified aggregate.

### *3.6. REMOVAL OF PAVEMENT, CURB & GUTTER, AND SIDEWALK*

All removals shall include full-depth saw-cutting along removal lines. Should street light conductors be damaged during pavement, sidewalk, and/or curb & gutter removal/replacement, the Contractor shall replace the entire length of street light conductors between street light standards at his sole expense.

#### *3.6.1. REMOVE EXISTING PAVING*

This bid item is provided for the full-depth removal of pavement of all types. Where new pavement will later be installed, the Contractor shall remove 6-inches, or the depth shown on the plans, of subgrade material to provide room for paving base material.

For removal of concrete pavement, the Contractor shall “double saw” the pavement at the removal lines to eliminate the risk of spalling the pavement that is to remain. The Contractor shall repair all spalled concrete by removing and replacing the entire spalled panel to the next joint at his sole expense.

*3.6.2. REMOVE & REPLACE ASPHALT PAVEMENT*

This bid item is provided for the full-depth removal and replacement of various, typically small areas of asphalt pavement for the purpose of repairing deteriorated pavement. The work shall also include removal of 6-inches of subgrade material to provide room for base material under the new asphalt pavement.

The Contractor shall provide and install 6-inches of recycled crushed concrete for base material under the new pavement. All new asphalt paving shall be constructed in accordance with Section 2400 of these Specifications. The sides and bottom of the patch hole shall be cleaned and coated with tack, then patched with matching thickness, up to 9" thick, of asphalt in lifts not to exceed 3" each. Adequate compaction shall be obtained, and sufficient cooling shall occur for each lift, both in the sole opinion of the Engineer, prior to placing subsequent lifts.

*3.6.3. REMOVE & REPLACE CONCRETE PAVEMENT*

This bid item is provided for the full-depth removal and replacement of various, typically small areas of concrete pavement for the purpose of repairing deteriorated pavement. The work shall also include removal of 6-inches of subgrade material to provide room for base material under the new concrete pavement.

The Contractor shall provide and install 6-inches of recycled crushed concrete for base material under the new pavement. All new concrete paving shall be constructed in accordance with Section 2100 of these Specifications.

*3.6.4. REMOVE CURB AND GUTTER*

The Contractor shall remove the curb & gutter and 2-inches of subgrade material to provide room for bedding material where new sidewalk will be installed.

*3.6.5. REMOVE & REPLACE CURB AND GUTTER*

This bid item is provided for removal and replacement of various, typically short lengths of curb and gutter (mountable or standard) where the pavement and boulevard are to remain. The work shall include saw-cutting through the curb and gutter at each end of the removal, and also along the curb/pavement edge (curb flange) for the entire length of the curb and gutter to be removed. The Contractor shall remove 2-inches of subgrade material to provide room for bedding material under the new curb and gutter.

The Contractor shall provide and install 2-inches of ND Class 5 or recycled crushed concrete for bedding material under the new curb and gutter. All new curbs and gutters shall be constructed in accordance with Section 2100 of these Specifications. The new curb and gutter shall be tied into the existing curb with two 18-inch long No. 4 epoxy-coated deformed bars. The work shall also include removing debris from and patching any voids created in the pavement during curb and gutter removal.

*3.6.6. REMOVE CONCRETE SIDEWALK*

The Contractor shall remove the sidewalk and 2-inches of subgrade material to provide room for bedding material where new sidewalk will be installed.

*3.6.7. REMOVE & REPLACE SIDEWALK*

These bid items are provided for removal and replacement of various, typically short lengths of 4" or 6" thick sidewalk. The Contractor shall remove 2-inches of subgrade material to provide room for base material under the new sidewalk.

The Contractor shall provide and install 2-inches of ND Class 5 or recycled crushed concrete for bedding under the new sidewalk. All new sidewalks shall be constructed in accordance with Section 2300 of these Specifications.

3.6.8. *REMOVE & REPLACE ADA RAMP*

This bid item is provided for removal and replacement of sidewalk curb ramps where the adjacent sidewalk is to remain. The Contractor shall remove 2-inches of subgrade material to provide room for base material under the new ramp.

The Contractor shall provide and install 2-inches of ND Class 5 or recycled crushed concrete for bedding under the new ramp. All new sidewalk curb ramps shall be constructed in accordance with Section 2300 of these Specifications.

3.6.9. *REMOVE & REPLACE 6" CONCRETE DRIVEWAY*

This bid item is provided for removal and replacement of driveway aprons where necessary. The Contractor shall remove adequate-depth subgrade material to provide room for base material under the new driveway.

The Contractor shall provide and install 2-inches of ND Class 5 or recycled crushed concrete for bedding under the new driveway. All new driveway pavement shall be tied to adjacent existing driveway pavement with 18-inch long No. 4 epoxy-coated deformed bars spaced 24" O.C., and shall be constructed in accordance with Section 2300 of these Specifications.

3.6.10. *REMOVE EXISTING DRIVEWAY*

The Contractor shall remove adequate-depth subgrade material to provide room for base material under the new driveway.

**PART 4**  
**GUARANTEE, MEASUREMENT & PAYMENT**

4.1. GUARANTEE

The guarantee does not apply to removals, but shall be per the Contract for all pipe plugs.

4.2. MEASUREMENT AND PAYMENT

Removal areas may not be limited to those shown on the plans. Actual removal limits will be marked in the field by the Engineer prior to removal operations commencing. Pay quantities for non-lump-sum bid items will be adjusted based on actual removal quantities as determined by the Engineer by using field measurements or computerized mapping software as deemed appropriate by the Engineer.

All replacement of removed items shall be in accordance with the requirements of the applicable sections of these Specifications. The contractor will be responsible for all costs associated with removal & replacement of any items lying outside the marked removal limits that are damaged during construction.

Unless otherwise provided for in the bid documents, the contract unit price for each removal item shall include all labor, equipment, materials, and delivery necessary to saw-cut, remove, and dispose of the item as specified herein.

*4.2.1. CLEARING AND GRUBBING*

All costs for “clearing and grubbing”, including landfill fees, shall be included in the price bid for other items unless a bid item for CLEAR & GRUB is provided on the bid sheet, in which case all said costs shall be included in the contract unit price for CLEAR & GRUB.

*4.2.2. TREE REMOVAL*

Measurement and payment shall be made on a per tree basis, including removal of the stump, for trees measuring 6 inches in diameter or greater at a point 4.5 feet off the ground. All costs for removal of any/all trees smaller than this shall be considered incidental to the Contract.

#### 4.2.3. *TOPSOIL STRIPPING*

Where a volume-based bid item is provided on the bid sheet, the Engineer will calculate the volume of topsoil stripping to be paid by first determining the area of stripping that was performed by a method described above, then multiplying that area by an assumed topsoil thickness of 1 foot.

#### 4.2.4. *REMOVAL OF ASBESTOS-CEMENT PIPE (ACP)*

ACP removal and disposal shall be paid for under the REMOVE PIPE – ASBESTOS CEMENT bid item at the contract unit price per linear foot, irrespective of the depth and/or size of the pipe, which shall include the cost of removing and disposing all pipe material, pipe bend sections, jointing material, restraints, stainless steel stiffeners and all other appurtenances, and of handling, hauling, dewatering, trenching, sheeting, excavating and backfilling, restoring the surface equal to or better than the original condition to the satisfaction of the Engineer (unless separate bid item is provided), necessary permits, and all material or work necessary to remove and dispose of the pipe as specified in the Contract Documents and/or as directed by the Engineer, all of which shall be in accordance with all applicable federal, state and local regulations and requirements.

#### 4.2.5. *REMOVAL OF ALL OTHER TYPES OF PIPE*

Pipe removal and disposal shall be paid for under the REMOVE PIPE bid item for the type of pipe being removed (be it sanitary sewer, watermain, storm sewer, etc.) at the contract unit price per linear foot, irrespective of the depth, pipe material, and/or size of the pipe, which shall include the cost of removing and disposing all pipe material, pipe bend sections, jointing material, restraints, stainless steel stiffeners and all other appurtenances, and of flushing, handling, hauling, dewatering, trenching, sheeting, excavating and backfilling, restoring the surface equal to or better than the original condition to the satisfaction of the Engineer (unless separate bid item is provided), necessary permits, and all material or work necessary to remove and dispose of the pipe as specified in the Contract Documents and/or as directed by the Engineer, all of which shall be in accordance with all applicable federal, state and local regulations and requirements. All costs for removal of service pipes being replaced shall be included in the contract unit price of the size and type of pipe being installed.

*4.2.6. REMOVAL OF CASTINGS, VALVES, AND HYDRANTS*

All costs for removal and disposal (delivery to City per **Part 2** above) of valves and hydrants as specified in PART 2 above shall be incidental to the removal of water main.

All costs for removal and disposal (delivery to City per **Part 2** above) of manhole/inlet castings as specified above shall be included in the price bid for other items.

*4.2.7. ABANDONMENT AND PLUGGING OF PIPES*

Abandonment of pipe will not be a pay item. Where a bid item for plugging is provided, plugging the ends of abandoned pipe will be paid for at the contract unit price for the size/type of plug to be installed, regardless of plugging method. Otherwise, all costs for plugging existing pipes shall be included in the price bid for other items.

*4.2.8. ABANDONMENT OF MANHOLES/INLETS*

Abandonment of manholes/inlets will be paid for at the contract unit price for each manhole/inlet abandoned in accordance with these Specifications. Payment shall include all costs for plugging all pipe leads inside the manhole/inlet, top section removal, and all backfill.

*4.2.9. REMOVAL OF MANHOLES AND INLETS*

Removal of manholes/inlets shall be paid for under the corresponding REMOVE MANHOLE or REMOVE INLET bid item at the contract unit price per each, irrespective of depth, material, and/or size, which shall include all costs to remove the base, barrel, adjusting rings, and casting in accordance with these Specifications.

*4.2.10. REMOVE EXISTING PAVING*

Payment shall be considered full compensation for removing and disposing of existing pavement with no differentiation in payment based on thickness or type, as well as removing the subgrade material to the depth specified if applicable.



*4.2.11. REMOVE & REPLACE ASPHALT PAVEMENT*

This bid item shall include all costs for the work to remove the existing pavement with no differentiation in payment based on thickness, remove subgrade material to the depth specified, and install new base material and pavement in its place as specified herein.

*4.2.12. REMOVE & REPLACE CONCRETE PAVEMENT*

This bid item shall include all costs for the work to remove the existing pavement of thickness noted in the bid item, remove subgrade material to the depth specified, and install new base material and pavement in its place as specified herein.

*4.2.13. REMOVE CURB & GUTTER*

This bid item shall include all costs for the work to remove the existing curb & gutter with no differentiation in payment based on type or size, and to remove subgrade material to the depth specified herein.

*4.2.14. REMOVE & REPLACE CURB & GUTTER*

This bid item shall include all costs for the work to remove the existing curb & gutter and subgrade material, and install new base material and curb & gutter in its place as specified herein.

*4.2.15. REMOVE CONCRETE SIDEWALK*

Removal of sidewalk will be paid for at the contract unit price for the corresponding thickness of sidewalk to be removed, which shall include all costs for the work to remove the existing sidewalk with no differentiation in payment based on width, and to remove subgrade material to the depth specified herein.

*4.2.16. REMOVE AND REPLACE SIDEWALK*

This bid item shall include all costs for the work to remove the existing sidewalk with no differentiation in payment based on width, remove subgrade material to the depth specified, and install new base material and sidewalk in its place as specified herein.

*4.2.17. REMOVE AND REPLACE ADA RAMP*

This bid item shall include all costs for the work to remove the existing sidewalk curb ramp with no differentiation in payment based on width or thickness, remove subgrade material to the depth specified, and install new base material and sidewalk curb ramp in its place as specified herein. Detectable warning panels are paid for under a separate bid item.

*4.2.18. REMOVE AND REPLACE 6" CONCRETE DRIVEWAY*

This bid item shall include all costs for the work to remove the existing concrete driveway with no differentiation in payment based on width, remove subgrade material to the depth specified, and install new base material and driveway in its place as specified herein.

*4.2.19. REMOVE EXISTING DRIVEWAY*

This bid item shall include all costs for the work to remove the existing driveway with no differentiation in payment based on width, thickness, nor material, and removal of the subgrade material to the depth specified.

*4.2.20. OTHER COSTS*

All other costs for work necessary to properly complete the work specified herein including, but not limited to trenching and backfilling per Section 1000 of these Specifications, shall not be bid items; the costs shall be charged to other items unless a bid item is specifically included on the bid sheet.

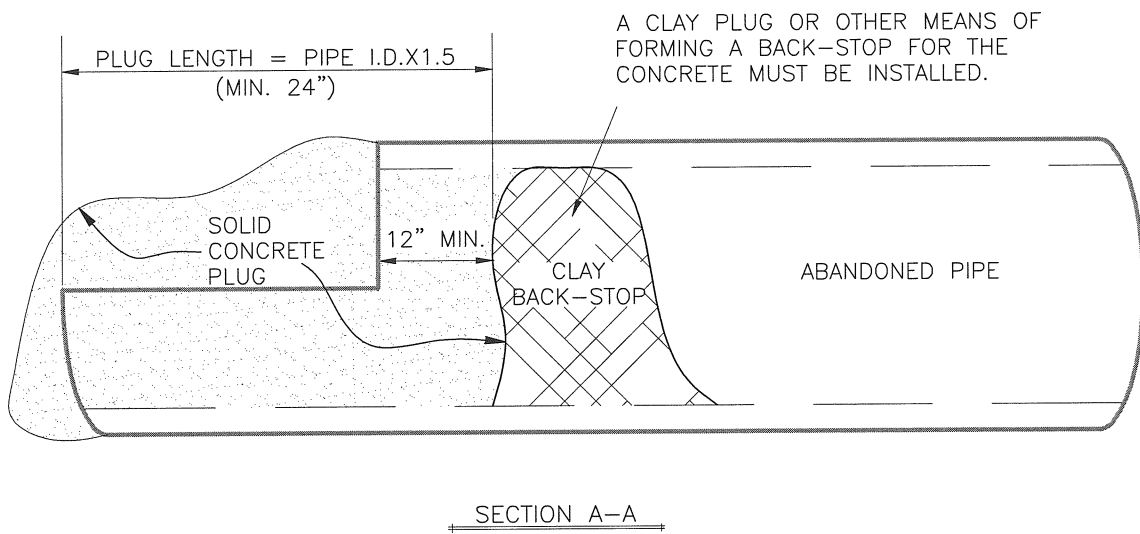
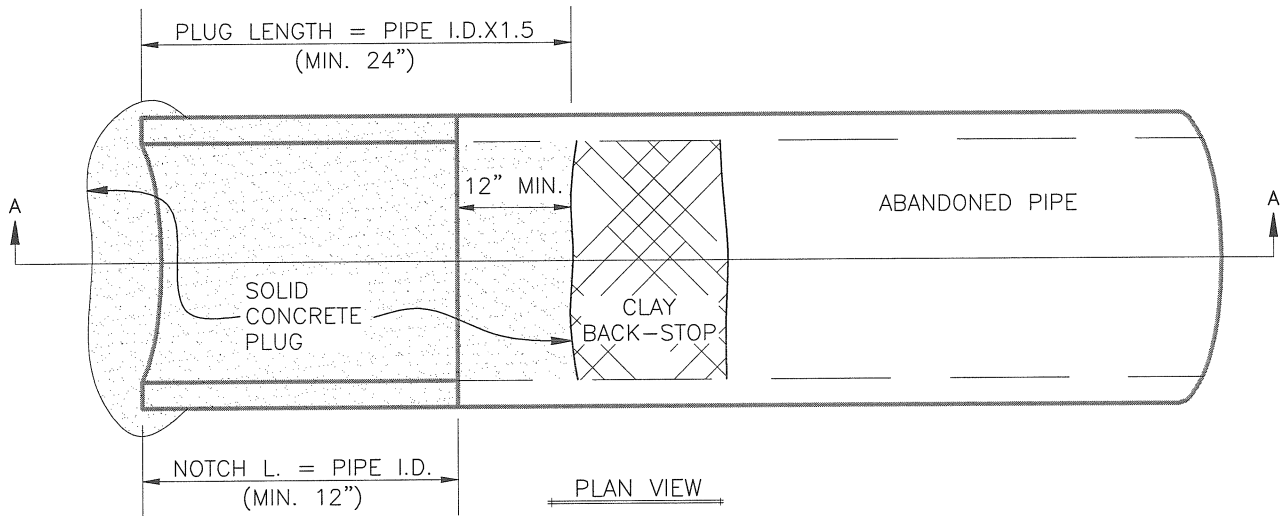

WHERE ALLOWED BY THE ENGINEER,  
A CONCRETE PLUG MAY BE USED TO PLUG  
THE ENDS OF ABANDONED PIPE.

NOTCH & REMOVE TOP OF PIPE DOWN TO  
THE SPRING LINE.

PLUG PIPE 12" OR SMALLER SHALL HAVE A  
CUT OPENING OF AT LEAST 12".

FILL VOID UP TO CLAY BACK-STOP WITH  
LOW SLUMP CONCRETE UP TO THE TOP OF  
PIPE.

SECTION NO. 1050	DRAWING NO. 5.1
REV.D. 2012	
<b>CONCRETE PLUG (WHERE ALLOWED)</b>	
CITY OF FARGO ENGINEERING DEPARTMENT	
APPROVED <i>BED</i>	DATE <i>2-21-2012</i>

**CITY OF FARGO SPECIFICATIONS  
SANITARY SEWERS**

**PART 1  
DESCRIPTION OF WORK**

The work to be done under this section of the Specifications and the accompanying plans consists of the furnishing of all labor, material, accessories and equipment necessary to construct sewers in the City of Fargo. The work includes excavation, removal and replacement of paving where encountered; furnishing, laying and jointing pipe; making connections to existing sewers and manholes as necessary; constructing new manholes; protecting existing utilities and public and private property; backfilling trenches; bypass pumping and other work as may be necessary in order that the work may be completed in accordance with these Specifications and the plans accompanying them.

**PART 2**  
**MATERIAL**

2.1. SOLID WALL POLYVINYLCHLORIDE (PVC) SEWER PIPE

*2.1.1. MATERIAL*

The material shall conform to “Standard Specifications for Rigid Polyvinyl Chloride Compounds”, ASTM D-1784, Class 12454-B or 12454-C or 12364-C. The pipe shall be produced using a continuous extrusion process employing a prime grade of white unplasticized polyvinyl chloride.

*2.1.2. PIPE MANUFACTURE*

The PVC sewer pipe and fittings 8” in diameter shall meet ASTM D3034, SDR 26 requirements; 10” to 15” in diameter shall meet the requirements of ASTM D3034 SDR 35 minimum; PVC pipe and fittings larger than 15 inches in diameter shall meet the requirements of ASTM F 679, wall thickness T-1, pipe stiffness of 46 psi. When pipe is installed at depths of 18 feet or more, SDR 26 with a pipe stiffness of 115 psi shall be used.

*2.1.3. JOINTING*

The joint system shall be an integral bell gasketed joint that forms a watertight seal in accordance with ASTM Specification D3212 and F477.

*2.1.4. SERVICES*

Services shall be made by the use of in-line wyes or, with the Engineer’s approval, saddle wyes may be used. Saddle wyes shall be PVC with a rubber gasket and shall be installed as per the manufacturer’s recommendation and attached with two stainless steel straps.

2.2. CLOSED PROFILE POLYVINYL CHLORIDE SEWER PIPE

*2.2.1. MATERIAL*

The pipe and fittings be made of PVC plastic meeting the requirements of ASTM D-1784 having a minimum cell classification of 12364 -A.

### *2.2.2. MANUFACTURE*

The PVC profile wall pipe and fittings shall meet the requirements of ASTM F 794 latest edition and have a minimum pipe stiffness of 46 psi. Closed cell PVC pipe will only be allowed in 21-inch diameter or larger.

### *2.2.3. JOINTING*

The joint system shall be of the bell and spigot type with a gasket that meets the requirement of ASTM D3212 & F477 to form a watertight seal. Gaskets shall be factory installed and chemically bonded to the bell end of the pipe. Field cuts and field installed gaskets shall be done in accordance with the manufacturer's instructions and his recommended equipment and materials.

### *2.2.4. SERVICE CONNECTIONS*

Connections to the pipe shall be made with GPK in-line fittings, GPK saddle wyes, or "Inserta-Tee" as manufactured by Fowler Manufacturing or approved equal. Installation shall be as per the manufacturer's recommendation. Exposed channels in the PVC profile pipe shall be sealed with 3M industrial sealant 612, 3M 605 urethane adhesive, or Hilti C-100 sealant.

### *2.2.5. APPROVED MANUFACTURERS*

Vylon High Capacity and Diamond Plastics Pro-21 closed profile PVC pipes are approved products.

## *2.3. DUCTILE IRON PIPE*

### *2.3.1. MATERIAL*

Ductile iron pipe shall meet the requirements of ASTM A-746 Standards.

### *2.3.2. MANUFACTURE*

The ductile iron pipe will be push-on joint type and shall be coated on the exterior with bituminous and on the interior with a factory applied minimum nominal thickness of 40 mil polyethylene lining. All ductile iron pipe shall be encased in 8-mil polyethylene plastic film or 4-mil cross-woven polyethylene plastic film. Pipe shall be Class 53 and ductile pipe will only be used with the Engineer's prior approval.

### *2.3.3. JOINTING*

Joints shall meet the requirements of ANSI/AWWA C 111/A21.11.

### *2.3.4. SERVICES*

Services shall be made by the use of in-line wyes or, with the Engineer's approval, saddle wyes may be used. Saddle wyes shall be PVC with a rubber gasket and shall be installed as per the manufacturer's recommendation and attached with two stainless steel straps.

## 2.4. REINFORCED CONCRETE PIPE

### *2.4.1. MATERIAL*

Material, manufacture and testing of reinforced concrete pipe shall comply with ASTM C76 and to Section 1500-2.1 of these Specifications.

### *2.4.2. MANUFACTURE*

The class and wall type will be as indicated on the plan sheets and shall meet the testing requirements as set forth in the latest edition of ASTM C76. All interior surfaces shall be spray coated with a 14-20 mil thick coating of Coal Tar Epoxy. Special coatings, if required, shall be as specified in the special instructions on the particular project. Concrete pipe will only be allowed when directly specified on the plans.

### 2.4.3. *PVC SHEET LINER*

#### 1. General

All work for and in connection with the installation of the lining in concrete pipe, and the field sealing and welding of joints, shall be done in strict conformity with all applicable specifications, instructions, and recommendations of the lining manufacturer.

The manufacturer of the lining shall furnish an affidavit attesting to the successful use of its material as a lining for sewer pipes for a minimum period of ten years in sewage conditions recognized as corrosive or otherwise detrimental to concrete.

#### 2. Material

2.1. Liner shall be Ameron T-Lock as manufactured by Ameron Protective Linings Division or approved equal.

#### 2.2. Composition

The liner must be continuous and free of pinholes, both across the joints and in the liner itself. The material used in the liner and in all joint, corner, and welding strips shall be a combination of poly (vinyl chloride) resin, pigments, and plasticizers, specially compounded to remain flexible. Poly (vinyl chloride) resin shall constitute not less than 99 percent, by weight, of the resin used in the formulation. Copolymer resins will not be permitted.

#### 2.3. Physical Properties

2.3.1. All plastic liner plate sheets, joint, corner, and welding strips shall have the following physical properties when tested at 77°F+/-5°.



Property	Initial	(Par.2.4)
Tensile strength	2200 psi min.	2100 psi min.
Elongation at break	200% min.	200% min.
Shore durometer, Type D	1 sec. 50 - 60 10 sec. 35 - 50	+/- 5 with respect to +/- 5 initial test result
Weight change		+/- 1.5

2.3.2. Tensile specimens shall be prepared and tested in accordance with ASTM D412 using die B.

2.3.3. Liner plate locking extensions embedded in concrete shall withstand a test pull of at least 100 pounds per linear inch, applied perpendicularly to the concrete surface for a period of one minute, without rupture of the locking extensions or withdrawal from embedment. This test shall be made at a temperature of 70 - 80° F inclusive.

2.3.4. The lining shall have good impact resistance, shall be flexible, and shall have an elongation sufficient to bridge up to 3-inch settling cracks, which may occur in the pipe or in the joint after installation, without damage to the lining.

2.3.5. The lining shall be repairable at any time during the life of the pipe or structure.

#### 2.4. Chemical resistance

After conditioning to constant weight at 110° F, tensile specimens and weight change specimens shall be exposed to the following solutions for a period of 112 days at 77° F +/- 5°.

At 28-day intervals, tensile specimens and weight change specimens shall be removed from each of the chemical solutions and tested in accordance with

Paragraph 2.3.2. If any specimen fails to meet the 112-day requirements before completion of the 112-day exposure, the material will be subject to rejection.

Chemical Solution	Concentration
Sulfuric acid	20% *
Sodium hydroxide	5%
Ammonium hydroxide	5% *
Nitric acid	1% *
Ferric chloride	1%
Sodium hypochlorite	1%
Soap	0.1%
Detergent (linear alkyl benzyl sulfonate or (LAS)	0.1%
Bacteriological	BOD not less than 700 ppm.

\* Volumetric percentages of concentrated C.P. grade reagents.

## 2.5. Pipe-size sheets and accessories

2.5.1. Pipe linings shall be a minimum of 0.065 inches in thickness and supplied as pipe-size sheets, fabricated by shop-welding the basic-size sheets together. Shop welds shall be made by lapping sheets a minimum of 2 inch and applying heat and pressure to the lap to produce a continuous welded joint.

Tensile strength measured across shop-welded joints measured in accordance with ASTM D412 shall be at least 2000 psi.

2.5.2. Sheets shall be supplied in prefabricated, pipe-sized tubular-shaped sheets, ready to lower onto the inner pipe forms. Transverse flaps shall be provided at the ends of sheets for pipe.

2.5.3. Welding strips Joint strips shall be sized per manufacturer's recommendations.

2.5.4. Prior to preparing the sheets for shipment, they shall be tested for pinholes using an electrical spark tester set between 18,000 – 22,000 volts. Any holes shall be repaired and retested.

### 3. Installation of lining

#### 3.1. General

3.1.1. Lining shall be cast integral with the pipe at the pipe manufacturer's facility. Installation of the lining, including preheating of sheets in cold weather and the welding of all joints, shall be done in accordance with the recommendations of the lining manufacturer.

3.1.2. Coverage of the lining shall not be less than the minimum shown on the plans.

3.1.3. All nail and tie holes and all cut, torn, and seriously abraded areas in the lining shall be patched. Patches made entirely with the welding strip shall be fused to the liner over the entire patch area. Larger patches may consist of smooth liner sheet applied over the damaged area with adhesive. All edges must be covered with welding strip fused to the patch and the sound lining adjoining the damaged area.

3.1.4. Care shall be exercised in handling, transporting, and placing lined pipe to prevent damage to the lining. No interior hooks or slings shall be used in lifting pipe. All handling operations shall be done with an exterior sling or with a suitable fork lift.

- 3.1.5. On pipe having 360° liner coverage, the longitudinal edges of the sheet shall be butt welded. When pipe tubes are furnished, these are shop-welded joints made in accordance with 2.6.1.
- 3.1.6. No pipe with damaged lining will be accepted until the damage has been repaired to the satisfaction of the Engineer.
- 3.2. Field joints in lining for concrete pipe
- 3.2.1. No lining joint shall be made until after the trench has been back-filled and consolidated. Pipe joints must be dry before lining joints are made.
- 3.2.2. Field joints in the lining at pipe joints shall be made according for liner manufacturer recommendations.
- 3.2.3. All welding of joints is to be in strict conformance with the specifications and instructions of the lining manufacturer.
- 3.3. Testing and repairing damaged surfaces
- 3.3.1. After the pipe is installed in the trench, all surfaces covered with lining, including welds, shall be tested with an electrical holiday detector as approved by the lining manufacturer with the instrument set between 18,000 – 22,000 volts.
- All welds shall be physically tested by a nondestructive probing method. All patches over holes, or repairs to the liner wherever damage has occurred, shall be accomplished in accordance with Paragraph 3.1.8.
- 3.3.2. Each transverse welding strip which extends to a lower edge of the liner will be tested by the purchasing agency. The welding strips shall extend 2 inches below the liner to provide a tab. A 10-pound pull will be applied to each tab. The force will be applied normal to the face of the structure by means of a spring balance. Liner adjoining the

welding strip will be held against the concrete during application of the force. The 10-pound pull will be maintained if a weld failure develops, until no further separation occurs. Defective welds will be retested after repairs have been made. Tabs shall be trimmed away neatly by the installer of the liner after the welding strip has passed inspection. Inspection shall be made within 2 days after joint has been completed in order to prevent tearing the projecting weld strip and consequent damage to the liner from equipment and materials used in or taken through the work.

A. Welders/Fusers

All welders/fusers for the PVC liner shall be precertified by Ameron or approved manufacturer prior to the start of work. All joints shall be numbered and initialed by the welder. The inspector will record on a daily basis the number of the joint and the welder at the end of each working day.

B. Factory Representative

The Contractor will make provisions to have a factory representative knowledgeable in joint fusing present at least one day during the first week of welding, and again at the time of the final inspection, to aid both the Contractor and the City in the detection of faulty welds, and to ensure the quality of the welds.

C. Final Inspection

The Contractor shall provide adequate ventilation, lighting and equipment (to include a cart/skateboard and tools) to allow for final inspection of all welds prior to putting the line in service.

#### *2.4.4. JOINTING*

Joints shall be of the bell and spigot type with a rubber “O”-ring type gasket that forms a watertight seal. Joints shall meet the requirements of ASTM C 443 OR C 361.

#### *2.4.5. SERVICES*

Services shall be made with “Inserta-Tee” as manufactured by Fowler Manufacturing Company or approved equal. The service hole in the pipe shall be cored to the recommended diameter and the tee installed as per the manufacturer’s recommendation.

2.5. CENTRIFUGALLY CAST FIBERGLASS-REINFORCED POLYMER MORTAR (CCFRPM) PIPE*2.5.1. MATERIAL*

This pipe shall have a stiffness of 72 psi and a pressure rating of 150 psi. It must meet AWWA C905 specifications. Each pipe shall be hydrostatically tested at the factory to two times the working pressure. The resin must meet the requirements of ASTM D3754 with the joints meeting ASTM D4161.

Installed pipe shall be pressure and leakage tested at 125 psi for a minimum of 30 minutes. Pressure and leakage shall be in accordance Section 1300 of these Specifications.

*2.5.2. MANUFACTURE*

Approved is HOBAS Pipe USA or approved equal.

*2.5.3. INFILTRATION TESTING*

Infiltration testing shall be performed on the new sanitary sewer line. The allowable limits of infiltration shall not exceed a rate of 100 gallons per inch of internal pipe diameter per mile per 24 hours with no allowance for manholes. Duration of all tests shall be a minimum of 2 hours. No more than 1500 feet of sewer shall be tested at any one time. Prior to testing for infiltration the system shall be pumped out so that normal infiltration conditions exist at the time of testing. The amounts of infiltration shall be determined by pumping the infiltrated water into calibrated drums, or by other approved methods.

*2.5.4. SERVICES*

Services shall be made with "Inserta-Tee" as manufactured by Fowler Manufacturing Company or approved equal. The service hole in the pipe shall be cored to the recommended diameter and the tee installed as per the manufacturer's recommendation.

## 2.6. MANHOLES

### *2.6.1. MATERIAL*

Manholes shall meet the requirements of ASTM C478 and shall be furnished with an approved casting (Neenah R-1733 or EJ1205Z or approved equal) with a self-sealing lid, concealed pick bar, and the word "SANITARY" (or words "SANITARY SEWER") cast into the center of the lid in letters at least one inch high.

### *2.6.2. MANUFACTURE*

The manholes shall be constructed in accordance with the detail drawings included as part of these Specifications. The manhole shall be furnished with an eccentric-type cone section. All manhole bases shall be monolithic or, if approved by the Engineer, a precast base or mini-tee manhole may be used. The main sewer shall be carried through manholes by split pipe whenever practicable. The concrete manhole shelves shall slope from the top edges of the invert at a rate of 2" per foot. When split pipe is not possible due to breaks in grade or elevation, the sewer invert shall be made of concrete. The shape of the invert shall conform exactly to the lower 1/3 of the pipe it connects and be left smooth and clean. Side branch inverts shall be constructed with as large radius of curvature as possible.

### *2.6.3. JOINTS*

Connections to sewer pipe larger than 36" diameter shall be made with a resilient watertight seal integrally cast as part of the manhole. Smaller pipes may be connected to the manhole similarly, or with a resilient watertight pipe-to-manhole connector having all stainless steel components with no welds nor rivets. All resilient seals shall meet or exceed ASTM C-923 and be fastened to the sewer pipe by means of stainless steel bands. Joints between manhole sections shall be sealed with a butyl rubber gasket. The joint shall meet the requirements of ASTM 443 for pipe joints. PVC pipe connections to existing manholes shall be core-drilled and booted.

### *2.6.4. MANHOLE ADJUSTING RINGS*

Manhole adjusting rings shall be as specified in Section 1500 of these Specifications.

### 2.6.5. *LIFT HOLES*

Lift holes shall be manufactured to provide a watertight seal.

### 2.6.6. *MANHOLE SEALS*

The Contractor shall install watertight manhole seals on the sanitary manholes as designated in the plans. The Contractor shall have the option of using either internal or external manhole seals except where a type of seal is specifically designated by the Engineer. These seals shall be installed as per the manufacturer's recommendations. Extensions will be paid for under the bid item for "Install Watertight Manhole Seal Extension", and shall be able to cover a minimum adjusting ring/chimney height of 7 to 10 inches.

The Contractor shall verify the dimensions and determine which type of seal should be utilized and the number of extensions that will be required. If an internal seal is used, the sealing surface shall be clean and free of loose material and excessive voids. If the surface has minor irregularities, a bead of butyl-rubber caulking shall be applied to fill these voids. If the sealing surface is rough or has excessive voids, a low-shrink mortar sealing surface shall be installed. Any flanges or protrusions on the interior to the casting shall be removed and ground smooth.

If an external seal is used, the Contractor shall install the seal as per the manufacturer's recommendation. The exterior of the manhole and casting shall be wire-brushed clean and leveled and smoothed with a low-shrink mortar surface if necessary.

#### A. INTERNAL SEAL

Internal seal shall be as manufactured by Cretex Specialty Products, NPC Inc., Strike Products Polyethylene I/I Barrier or approved equal. The sealing bands and all mounting hardware (screws, bolts, nuts, etc.) shall be type 304 stainless steel. Any casting modifications, mortar leveling, casting adjustment, concrete removal and replacement (due to offsets, etc.) shall be incidental to this bid item. If the I/I Polyethylene I/I Barrier is used, it shall be installed as per the manufacturer's recommendation and the bottom surface of the I/I Barrier shall be sealed to the manhole cone top surface using a butyl sealant.

#### B. EXTERNAL SEAL



External seal shall be as manufactured by Cretex Specialty Products, NPC, Inc., WrapidSeal heat shrinkable sleeve system as manufactured by Conusa – CPS or approved equal. All concrete removal and replacement, excavation, backfill and casting adjustments shall be incidental to the bid item.

#### 2.7. SANITARY SEWER FORCE MAIN TRACER WIRE

The tracer wire shall be in accordance with the requirements of Section 1300 of these Specifications, except it shall be green in color. The pedestal shall be a Rhino Triview Flex Pedestal complete with 6' long "U" channel, post or approved equal.

#### 2.8. INSULATION

Insulation, where required by the Engineer, shall be extruded polystyrene (rigid), 2" thick unless noted otherwise, and shall be provided in 4' x 8' sheets, cut smaller where necessary.

**PART 3**  
**CONSTRUCTION**

3.1. GENERAL

Excavation, trenching and backfilling shall be done in accordance with Section #1000 of these Specifications. Pipe and fittings shall be handled and laid in accordance with the manufacturer's or industry standards. Pipe, fittings and manholes shall be laid in the location shown on the plans, the exact location being designated by the Engineer. The bell and spigot shall be wiped clean and sufficient lubrication placed on the gasket and spigot end before the pipe is fully pushed into the bell. Field cut spigot ends shall be beveled prior to being pushed into the bell. Every part of the pipe shall be bedded uniformly throughout its length. Pipe shall be laid upgrade with the spigot end pointing in the direction of flow. All sewers must be kept thoroughly clean. When the trench is left at night or the pipe laying stopped, the upper end of the pipe must be closed with an end board or cap to prevent dirt and sand from entering the pipe.

3.2. ALIGNMENT

The Engineering Department will provide line and grade for all sanitary sewer pipes. Grade and alignment shall be maintained by the use of a line parallel to the grade and line of the sewer. This line is to be supported above the ground on batter boards spaced 50 feet or less apart and rigidly anchored to and supported by steel post driven into the ground.

Not less than 3 batter boards shall be maintained at all times. The Engineer shall be immediately notified of any misalignment of the batter boards set in accordance with the grade and alignment of the tacked offset stakes provided.

Electronic grade control is allowed, however the Contractor will be required to install and maintain batter boards and periodically check the line & grade from the offset stakes provided. In no instance will the Contractor be allowed to change the alignment or grade without the permission of the Engineer.

### 3.3. INSTALLATION OF WYE BRANCHES

Wye branches shall be located at the points designated by the Engineer. The Contractor shall ensure that the wye branches have been marked in advance of the construction of the sewer. If the locations have not been marked, the Contractor shall stop sewer construction until such time as the location (s) has been obtained. Wye branches shall not be installed causing the location of the service to be on the lower 1/2 of the sewer main. The location of the wye branch with reference to the nearest down-stream manhole shall be accurately determined and recorded together with the direction it faces.

### 3.4. INSTALLATION OF RISERS

If the sewer depth exceeds 12 feet in depth, risers shall be installed. This shall be done by installing a wye in the main sewer and placing a length of pipe sufficiently long to reach within 10' of the sidewalk grade. On risers of 5 feet or greater, 1 1/4" crushed rock shall be used to encase the wye and support the vertical bend outside of the wye. Work shall conform to the detailed drawings for sewer service connections and placed at the location shown on the plans or as ordered by the Engineer.

### 3.5. INSTALLATION OF SERVICE CONNECTIONS

Service connections on new construction shall have the risers laid on a slope not to exceed 2 feet vertically to 1 foot horizontally. The pipe shall be laid so that it has solid bearing on undisturbed earth. The service pipe shall make a horizontal angle with the wye branch or slant that ensures a proper connection is made. The first length of pipe shall not make a total angle with the branch or slant greater than 4 inches in two feet, and the wye branch or slant shall be installed in such a manner as to fit the alignment of the branch service line as closely as possible. On all new construction sewer services shall be installed as the sewer main is installed so that the backfill of the sewer main trench and the sewer service trench will be done in one continuous operation.

### 3.6. TRANSFER SEWER SERVICE

When it is indicated on the plans to transfer existing service connections to the new sewer and this item is included as a bid item, it shall be done in accordance with Section 1400 of these Specifications.

### 3.7. SEWER SERVICE REPAIRS

Repairs shall be in accordance with Section 1400 of these Specifications.

### 3.8. MANHOLES

The manhole base shall be set at the proper grade and alignment to provide a smooth transition from the incoming pipe (s) to the outgoing pipe. Manhole bases shall be bedded in 6" of 1 1/4" crushed rock. The area that is over-excavated adjacent to the manhole base and under the pipe shall be backfilled with 1 1/4" crushed rock to prevent settlement and provide for support for the pipe from the manhole edge to the regular trench excavation. Care shall be taken that the connection between the manhole and the pipe is watertight and the invert is smooth and continuous as it enters and exits the manhole.

### 3.9. CASTING TO GRADE (BOULEVARD)

This bid item shall be in accordance with Section 1500 of these Specifications, except that all joints between the rings and the manhole, the rings and the frame, and in-between rings shall be constructed water-tight by a method recommended by the ring manufacturer. In lieu of the use of a sealant, an external mechanical frame-chimney seal may be used for a watertight installation.

### 3.10. DEFLECTION TEST

Deflection tests shall be performed by the Contractor on all flexible conduit sewers. Deflection tests shall be conducted after the final backfill has been in place at least 30 days. Deflection tests shall be made using a Go/No-Go device or other approved method. The Contractor shall provide the appropriate equipment to test the sewer main. The diameter of the Go/ No-Go device or rigid mandrel shall be 95% of the undeflected inside diameter of the flexible pipe. The mandrel design shall have nine or more "legs". The Contractor is required to install and bed the pipe in such a manner as to limit the diametric deflection to less than 5%. All pipes exceeding 5% deflection shall be re-laid or replaced by the Contractor at his expense and at no additional cost to the owner.

### 3.11. LOW PRESSURE AIR TESTING

Upon completion of the sewer, before house services are connected to the pipe line, and after the line has been backfilled and cleaned, the Contractor shall furnish all necessary equipment and personnel to conduct a low pressure air test on all gravity plastic pipe sewer lines sized 30 inches in diameter or less. The test shall be conducted in the presence of the City's project representative

between two manholes in succession and in accordance with ASTM F-1417, as modified herein. The Contractor shall notify the representative a minimum of 48 hours prior to testing. All costs for performing the test shall be included in the price of the installed pipe.

The sewer pipe section under test shall be clean at the time of testing, but the pipe may be wetted. Pneumatic plugs each having a length greater than the diameter of the pipe being tested shall be used to plug the pipe ends at manholes. One plug shall have the air supply hose and the return air pressure hose. The air supply hose, connected from the compressor to the plug, shall have a throttling valve, bleeding valve, and shut off valve for control. The air pressure tap shall have a sensitive pressure gauge, 1 to 10 psi range, protected by a gauge cock and a pressure relief valve set a 10 psi. The gauge must be in 0.1 pound increments. The testing gauge shall be located at ground level, out of and away from the manhole. Air shall be slowly introduced into the plugged line until the internal air pressure reaches 4.0 psig greater than the average back pressure of any ground water pressure that may submerge the pipe. At least two minutes shall be allowed for the air temperature to stabilize before readings are taken and the timing started, during which time the air supply shall be regulated to maintain the pressure between 3.5 and 4.0 psig. After the stabilization period the air supply shall be shut off and timing begun.

The sewer section under test will be accepted as having passed the low pressure air test if it does not lose air at a rate to cause the pressure to drop more than 0.5 psig in less time than ½ minute per inch diameter of the pipe tested. If the pipe fails to meet the requirements of the test, the Contractor shall, at his sole expense, determine the source of leakage and repair/replace defective material and/or workmanship, after which, the low pressure air test and deflection test, if applicable, shall be performed again.

To determine the air pressure to be added for the average ground water above the pipeline, the ground water height in feet above the pipeline shall be divided by 2.31, and that incremental pressure added to the gauge pressure. A table for converting water height to gauge pressure is as follows:

<b>Ground Water Level Over Top of Pipeline</b>	<b>Incremental Air Pressure to be Added to Gauge Pressure Readings</b>
1 foot	0.43 psig ( <i>4.43 psig total</i> )
2 feet	0.86 psig ( <i>4.86 psig total</i> )
4 feet	1.72 psig ( <i>5.72 psig total</i> )
8 feet	3.44 psig ( <i>7.44 psig total</i> )
10 feet	4.30 psig ( <i>8.30 psig total</i> )
Over 10 feet	<b><i>*DO NOT PERFORM TEST</i></b>

*\* If the air pressure required to run the test exceeds 8.3 psig, the Contractor shall lower the groundwater to acceptable levels by means of dewatering (incidental) and perform the test.*

### 3.12. TELEVISIONING

All gravity sewers shall be televised by the City of Fargo Street Department. Any abnormalities such as, but not limited to, deviations of grade, misaligned joints, cracked/defected pipe, rolled gaskets, shall be repaired by the Contractor at his expense. Sections requiring repair shall be re-televised to verify condition of repair. It is the Contractor's responsibility to provide drivable access to each manhole for the City of Fargo camera truck. Televising requires a 7 day advance notice and shall be scheduled through the inspector on site, and will be completed during normal City of Fargo Street Department hours. If the camera operator deems the pipe unsuitable for televising, the Contractor, at his expense, shall clean the sewer by means of jetting. Any/all costs associated with televising shall be incidental to other items.

### 3.13. SANITARY FORCE MAIN TRACER WIRE

All sanitary force main shall have a solid copper tracer wire secured to the sewer force main as it is being installed. Splices made to the tracer wire shall be sealed with a two-part mixture and enclosed in a plastic sleeve.

The tracer wire shall be looped up at pedestal locations or as directed by the Engineer. Enough wire shall be left above finished grade to allow connection into the pedestal fixture. A label shall be secured to the outside of the pedestal denoting "sewer locating line". All connections shall be made as per the manufacturer's recommendations.

Upon completion of the project the Contractor shall furnish a locator and using a low voltage circuit, test the entire tracer wire system in the presence of the Engineer. The test shall consist of a continuous above ground trace of the piping and appurtenances installed. All areas failing the location test shall be corrected at the Contractor's expense. The wire shall be tested in accordance with the requirements of ASTM B-1, B-3, B-8 and D-1248. All wire will be spark tested at 7500 VAC.

### 3.14. BYPASS PUMPING

The Contractor shall install a temporary bypass to maintain uninterrupted sewer service on sewer reconstruction or sewer repair projects where work will interfere with sewage flow in the existing sewer. The bypass shall be made by diverting the effluent flow at an upstream access manhole and pumping it through a separate conduit to a downstream reentry point or to an adjacent sewer

system. The pump and bypass conduit shall be of adequate size and capacity to handle the flow. The effluent level in the bypass pumping manhole shall not be allowed to rise more than 1 foot above the crown of the incoming sewer pipe. Bypass pumping shall be incidental to the sewer work.

Bypassing of sewage flow by means of plugging the existing sewer and providing for backflow of sewage through adjoining sewers may be allowed when existing piping is available and when approved by the Engineer.

On all temporary sanitary sewer bypass locations, the Contractor shall supply and maintain an overflow prevention monitor. The monitor shall be a field-ready corrosion resistant housing meeting IP67/NEMA 4, 4X standards with cellular communication capability. It shall be preprogrammed for the text service provider as designated by the Engineer. Unit must be designed for maintenance-free operation and non-confined space entry. Unit shall be provided with a field replaceable 6-volt Alkaline Lantern Battery and have the capability of transmitting text alerts to a minimum of three user-designated cell phones. Unit shall be Model 1<sup>st</sup> Response 8200 by Eastech Flow Controls, Upper River, NJ or approved equal.

**PART 4**  
**GUARANTEE, MEASUREMENT & PAYMENT**

4.1. GUARANTEE

The guarantee shall be per the contract.

4.2. MEASUREMENT AND PAYMENT

*4.2.1. GENERAL*

The cost of excavating and trenching shall be included as part of this specification.

*4.2.2. SANITARY SEWER PIPE*

Pipe will be measured by customary and conventional methods and paid for on a unit price basis for the actual length installed. Measurement will be from center of manhole to center of manhole or from end of existing pipe to center of manhole or end of pipe stubout. No additional or direct payment will be made for the wyes or for the jointing of the pipes or manhole connections.

*4.2.3. WYE BRANCHES*

The cost of furnishing and installing the wye branches shall be included in the unit bid price per linear foot of sewer pipe in place.

*4.2.4. STANDARD AND DROP CONNECTION MANHOLES*

The cost of furnishing and installing the manholes will be paid for on a lump sum bid per each manhole installed. Costs shall include all excavation, bedding, backfilling, constructing, furnishing and installing the manhole and casting in place, connections to the sewer and sealing the manhole joints and lift holes. On Drop-Manholes all additional fittings, collars, pipe and appurtenances below the main sewer shall be included in the bid price.



*4.2.5. RISER PIPES*

Sewer service riser pipes will be paid for on a linear foot basis. The bid price shall include all bends, rock or concrete encasement if required, planking or any other incidental items required.

*4.2.6. DEFLECTION AND AIR TESTING*

No additional payment will be made for deflection and/or air testing. All costs for material, labor, and equipment necessary to complete the testing shall be included in the contract unit price per linear foot of sewer main installed.

*4.2.7. FORCE MAIN*

Pipe will be measured by customary and conventional methods and paid for on a unit price basis for the actual length installed. No additional or direct payment will be made for jointing, bends or connections.

*4.2.8. TRACER WIRE*

Payment for the tracer wire shall be incidental to the force main. The locating pedestal will be paid on a unit price per each basis and shall include all labor, material and equipment necessary to install one locating wire pedestal.

*4.2.9. OTHER COSTS*

All costs for work necessary to properly complete the work specified herein shall not be bid items; the costs shall be charged to other items unless a bid item is included on the bid sheet.

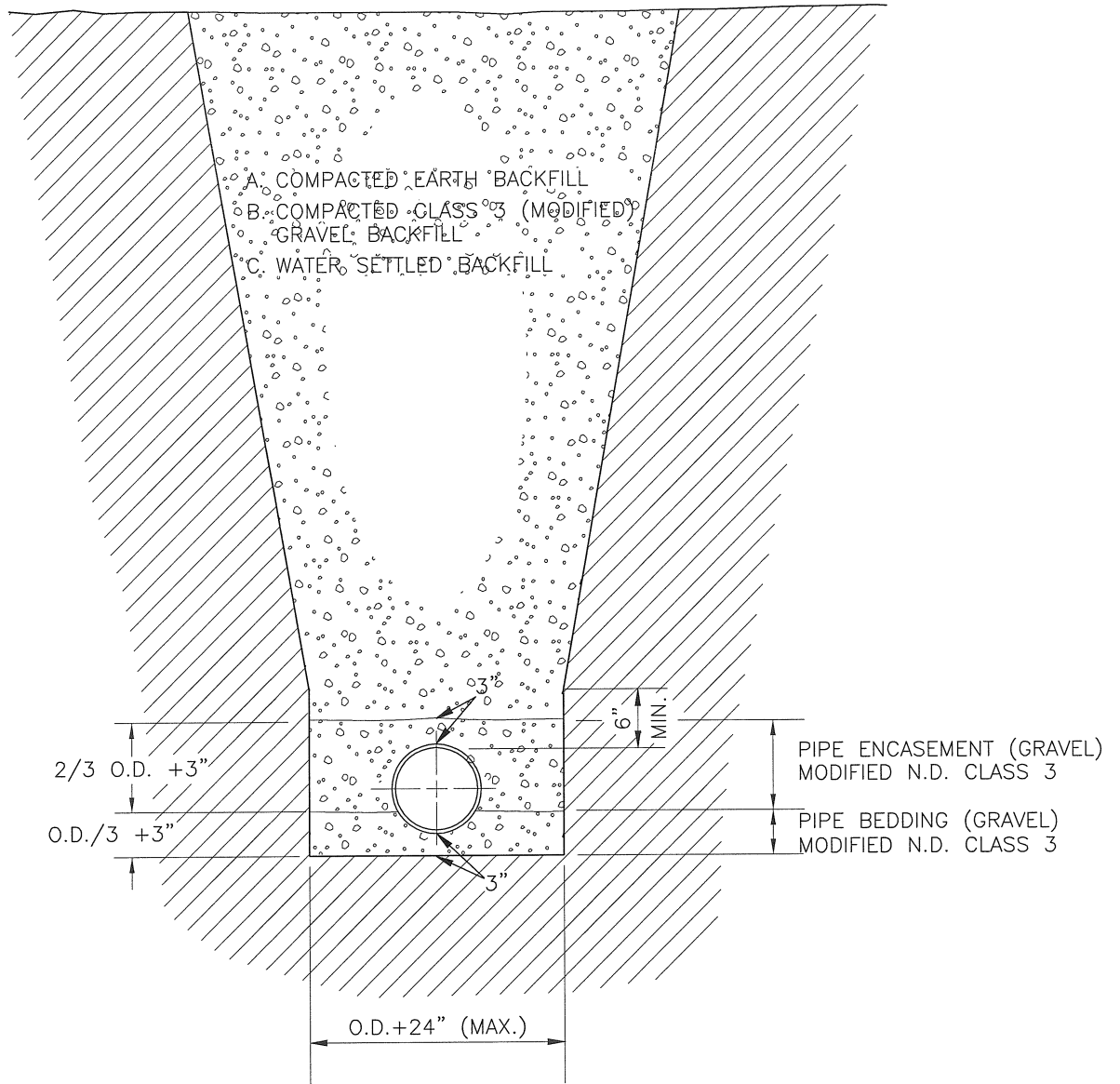

NOTE:

CRUSHED CONCRETE MEETING THE ND CLASS 5 AGGREGATE GRADATION REQUIREMENTS MAY BE SUBSTITUTED FOR THE PIPE BEDDING & ENCASEMENT MATERIAL.

SECTION NO.	1200	DRAWING NO.	5.1
REV.D.	2012		
<b>SANITARY SEWER TRENCH BACKFILL</b>			
CITY OF FARGO ENGINEERING DEPARTMENT			
APPROVED	<i>BED</i>	DATE	<i>2-21-2012</i>

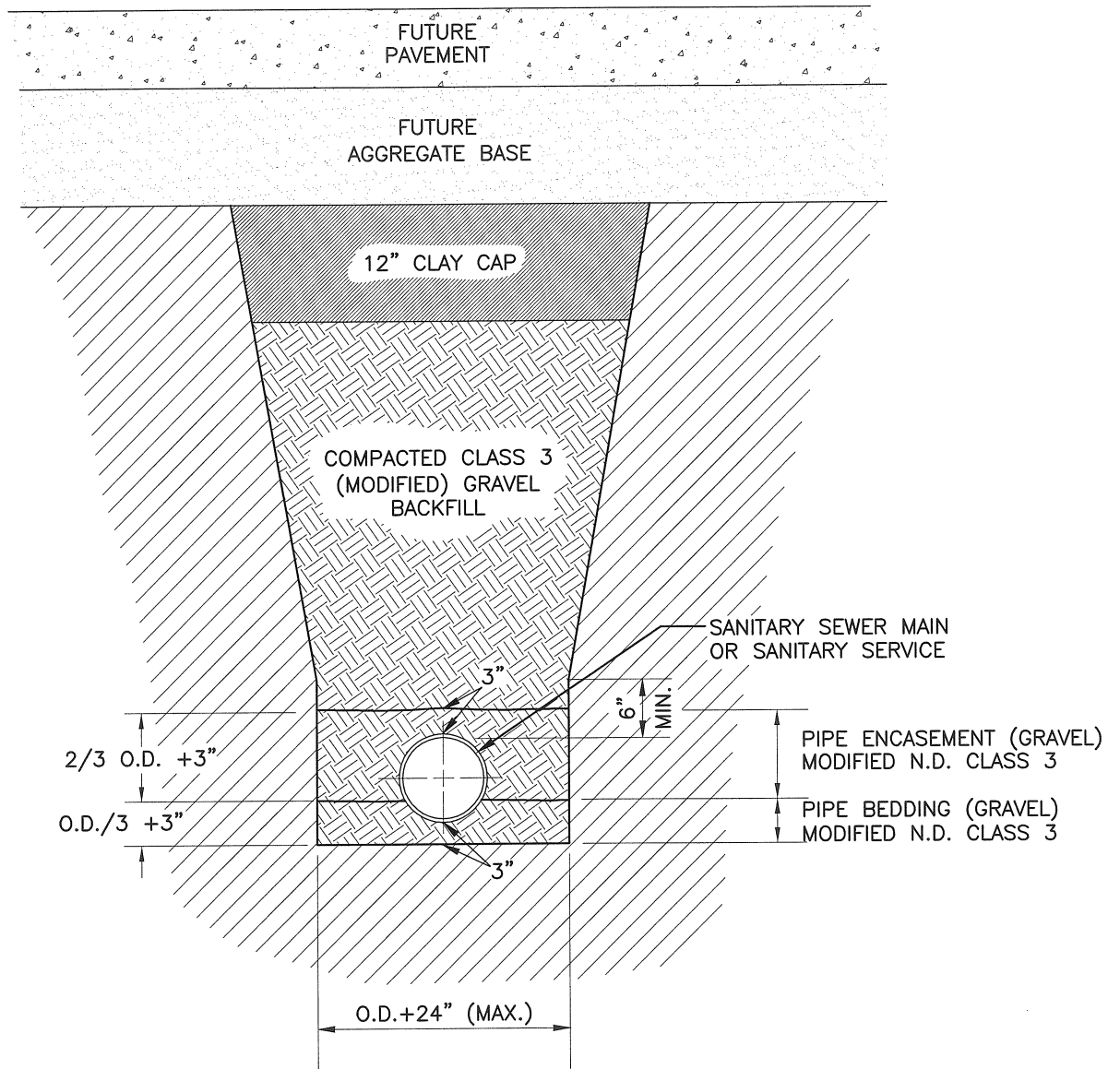

**NOTE:**

THIS DETAIL APPLIES WHERE SANITARY SEWER IS INSTALLED UNDER FUTURE PAVING WITH EDGE DRAIN.

SECTION NO.	1200	DRAWING NO.	5.2
REV.D.			
<i>SANITARY SEWER TRENCH UNDER NEW PAVEMENT</i>			
CITY OF FARGO ENGINEERING DEPARTMENT			
APPROVED	<i>BED</i>	DATE	<i>2-21-2012</i>

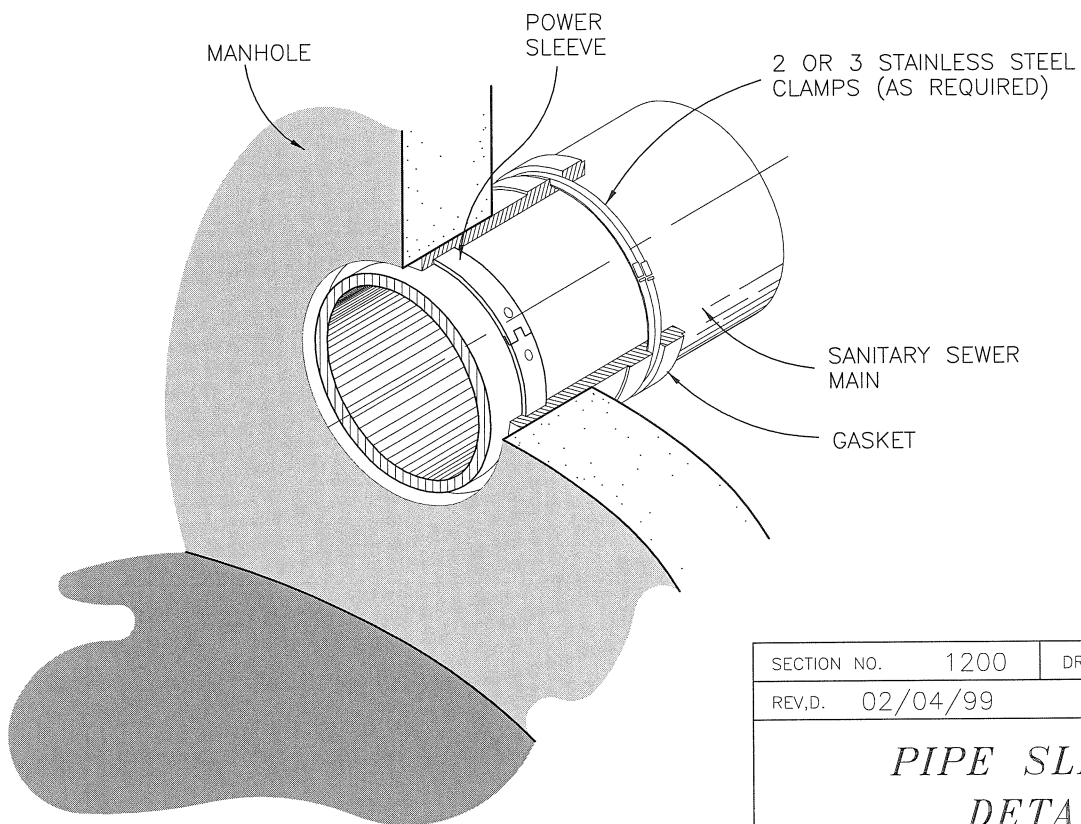
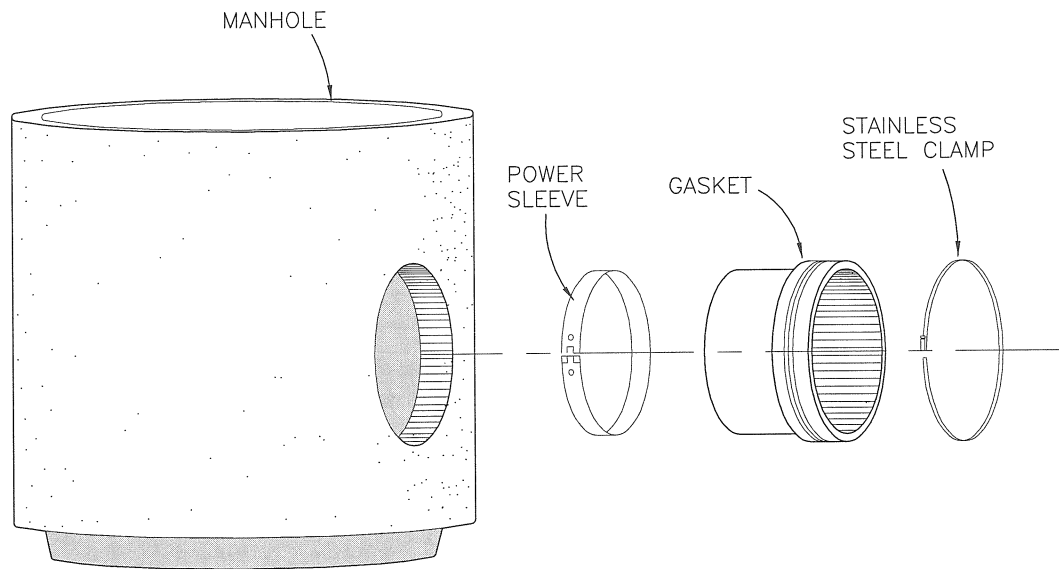

SECTION NO.	1200	DRAWING NO.	5.3
REV.D.	02/04/99		
<b>PIPE SLEEVE DETAIL</b>			
CITY OF FARGO ENGINEERING DEPARTMENT			
APPROVED	<i>BEO</i>		DATE <i>2-21-2012</i>

MANHOLE COVER SHALL HAVE  
 -CONCEALED PICK BAR  
 -"O" RING GASKET

CASTING FRAME & COVER  
 NEENAH FOUNDRY CO. R-1733  
 MUNICIPAL CASTINGS INC. 301-7/301A  
 EAST JORDEN 1205-AGSSA  
 OR APPROVED EQUAL

3-2" ADJUSTING RINGS

MANHOLE STEP  
 12" O.C.  
 (SEE DETAIL)

48" DIA. PRECAST  
 CONCRETE MANHOLE

PRECAST MONOLITHIC  
 MANHOLE W/GASKET  
 ASSEMBLY FOR 8"  
 TO 15" DIA. MAINS

1 1/4" CRUSHED ROCK  
 TO BE USED TO  
 SUPPORT PIPE IN  
 OVEREXCAVATED AREA  
 & 1/2 WAY UP PIPE

6" OF 1 1/4" ROCK  
 UNDER MANHOLE BASE

NOTE:  
 LIFT HOLES TO BE  
 MANUFACTURED  
 WATER PROOF

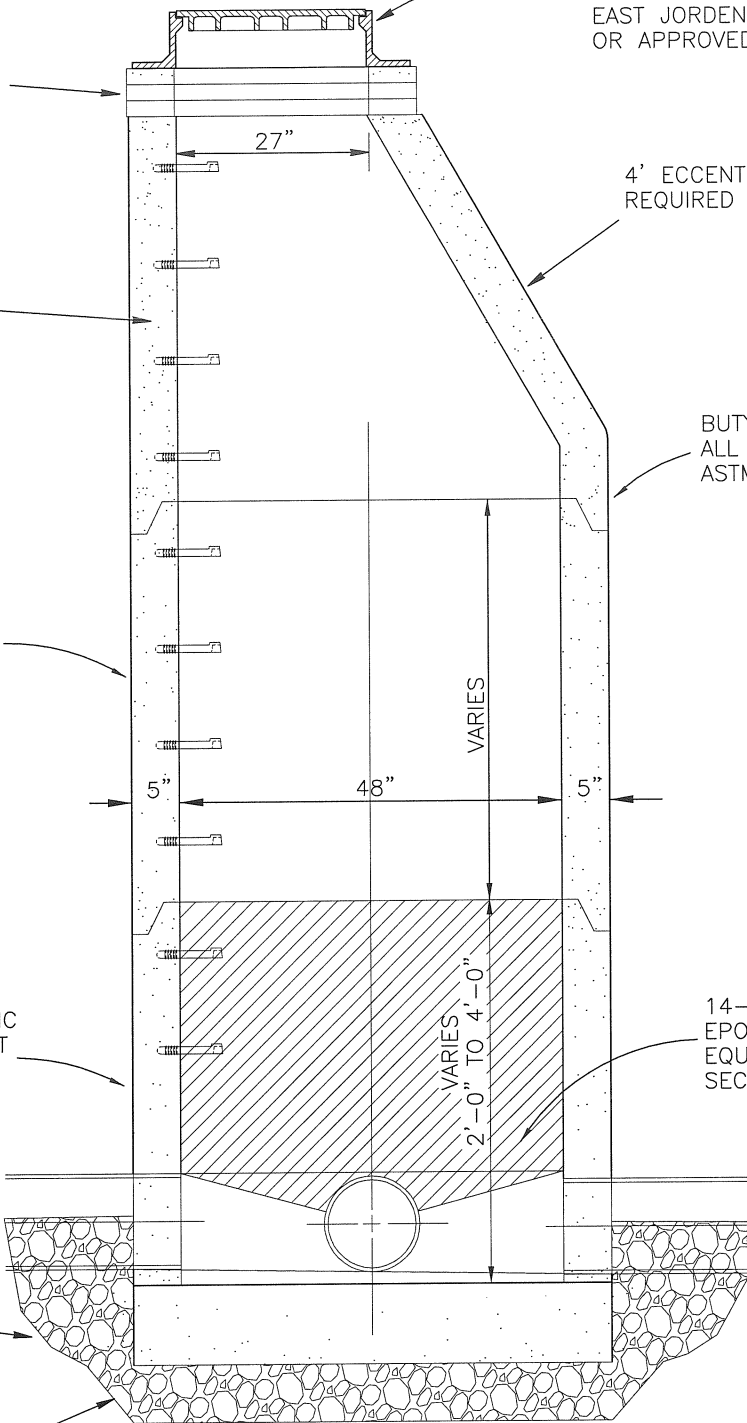

4' ECCENTRIC CONE  
 REQUIRED

BUTYL RUBBER GASKET ON  
 ALL JOINTS (JOINT TO MEET  
 ASTM 433 REQUIREMENT)

14-20 MILS OF COAL TAR  
 EPOXY OR APPROVED  
 EQUAL ON BOTTOM  
 SECTION OF MANHOLE

SECTION NO. 1200	DRAWING NO. 5.4
REV.D. 2012	
<b>SANITARY SEWER    MANHOLE DETAIL (8", 10"    12", 15" MAINS)</b>	
CITY OF FARGO ENGINEERING DEPARTMENT	
APPROVED <i>BED</i>	DATE <i>2-21-2012</i>

NOTE:  
 CASTING FRAME & COVER TO BE  
 NEENAH FOUNDRY CO. R-1733  
 MUNICIPAL CASTINGS INC. 301-7/301A  
 EAST JORDEN 1205-AGSSA  
 OR APPROVED EQUAL

MANHOLE COVER SHALL HAVE  
 -CONCEALED PICK BAR  
 -"O" RING GASKET

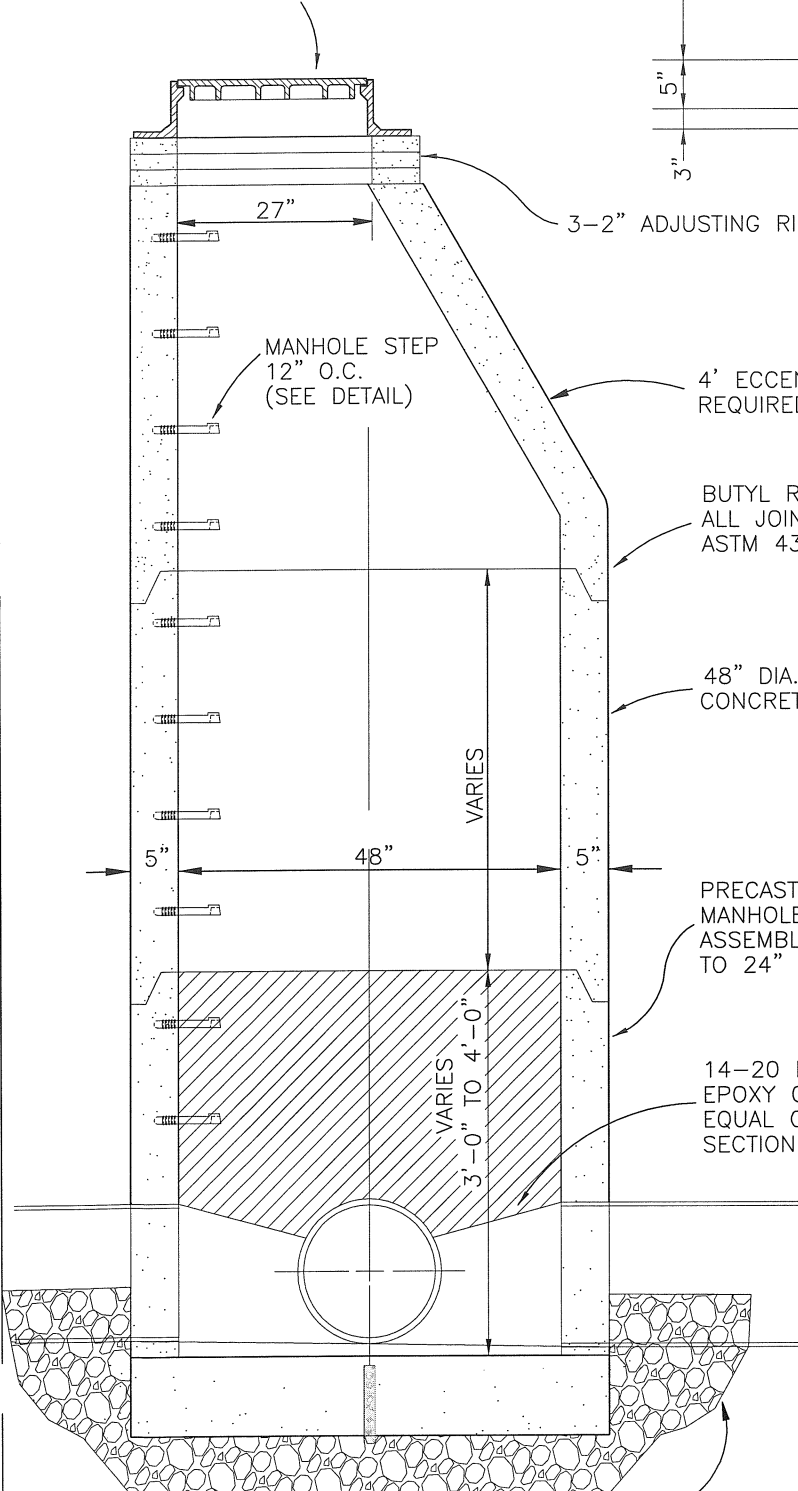
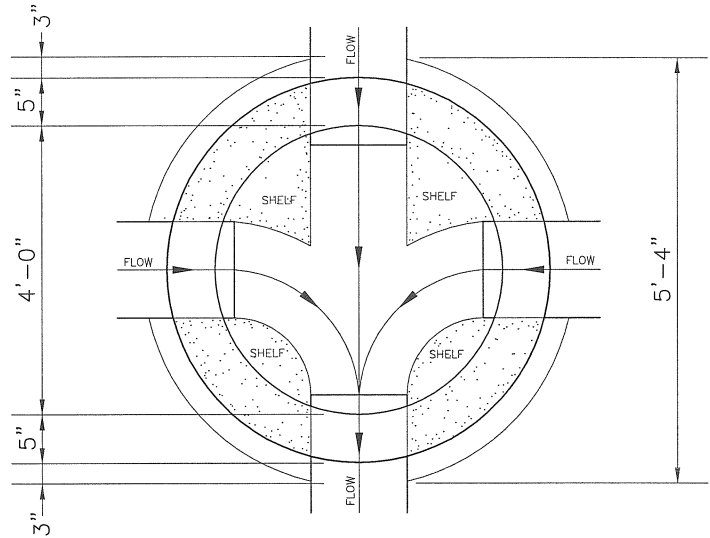

3-2" ADJUSTING RINGS

MANHOLE STEP  
 12" O.C.  
 (SEE DETAIL)

4' ECCENTRIC CONE  
 REQUIRED

BUTYL RUBBER GASKET ON  
 ALL JOINTS (JOINT TO MEET  
 ASTM 433 REQUIREMENTS)

48" DIA. PRECAST  
 CONCRETE MANHOLE

PRECAST MONOLITHIC  
 MANHOLE W/GASKET  
 ASSEMBLY FOR 18"  
 TO 24" DIA. MAINS

14-20 MILS OF COAL TAR  
 EPOXY OR APPROVED  
 EQUAL ON BOTTOM  
 SECTION OF MANHOLE

NOTE:  
 LIFT HOLES TO BE  
 MANUFACTURED  
 WATER PROOF

1 1/4" CRUSHED ROCK TO BE USED TO SUPPORT  
 OVER EXCAVATED AREA & 1/2 WAY UP PIPE.  
 6" OF 1 1/4" ROCK UNDER MANHOLE BASE

SECTION NO. 1200	DRAWING NO. 5.5
REV.D. 2012	
<b>SANITARY SEWER    MANHOLE DETAIL    (18" TO 24" MAINS)</b>	
CITY OF FARGO ENGINEERING DEPARTMENT	
APPROVED <i>BEO</i>	DATE <i>2-21-2012</i>

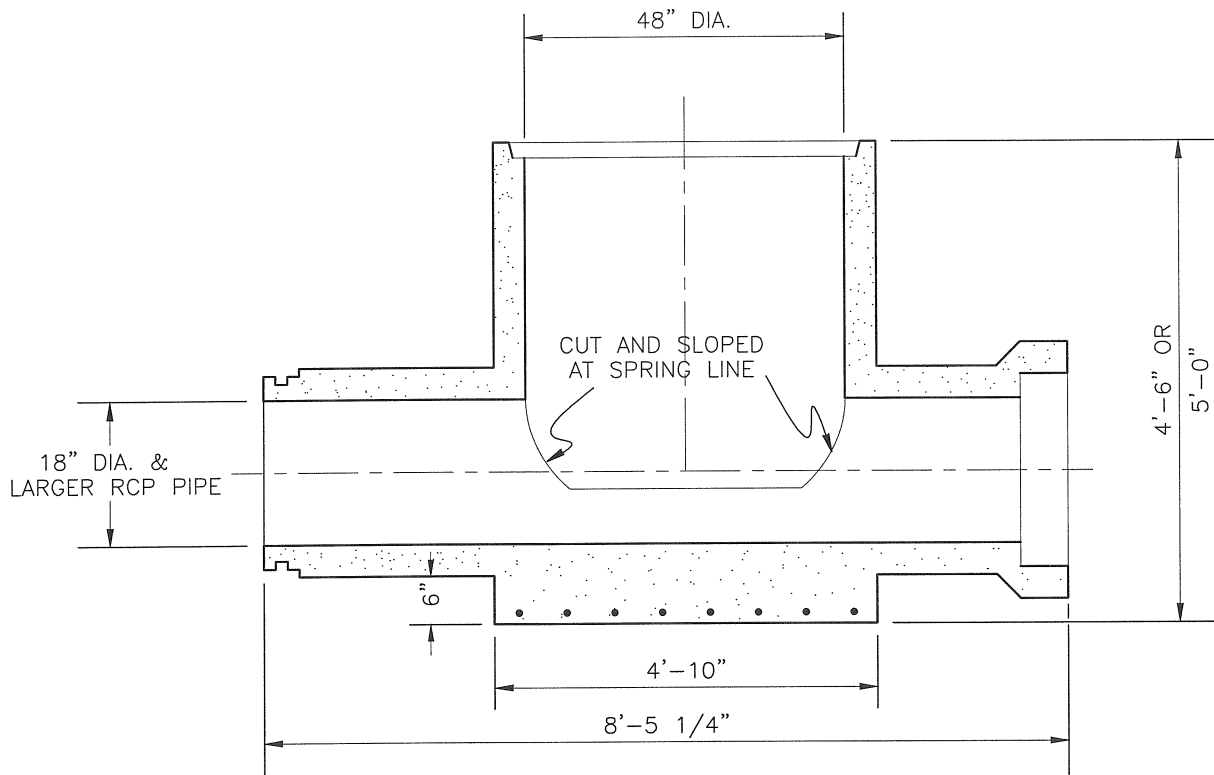

SECTION NO.	1200	DRAWING NO.	5.6
REV.D.	March, 1999		
<i>MINI-TEE MANHOLE DETAIL</i>			
CITY OF FARGO ENGINEERING DEPARTMENT			
APPROVED	<i>BED</i>	DATE	<i>2-21-2012</i>

CASTING FRAME & COVER  
 NEENAH FOUNDRY CO. R-1733  
 MUNICIPAL CASTINGS INC. 301-7/301A  
 EAST JORDEN 1205-AGSSA  
 OR APPROVED EQUAL

COVER SHALL HAVE  
 -CONCEALED PICK BAR  
 -"O" RING GASKET

NOTE:  
 INVERT AND LOWER MANHOLE SECTION  
 AS PER DETAILS:  
 5.4  
 (8", 10", 12", 15" MAINS)  
 5.5  
 (18", 21", & 24" MAINS & LARGER)  
 5.6  
 MINI-TEES

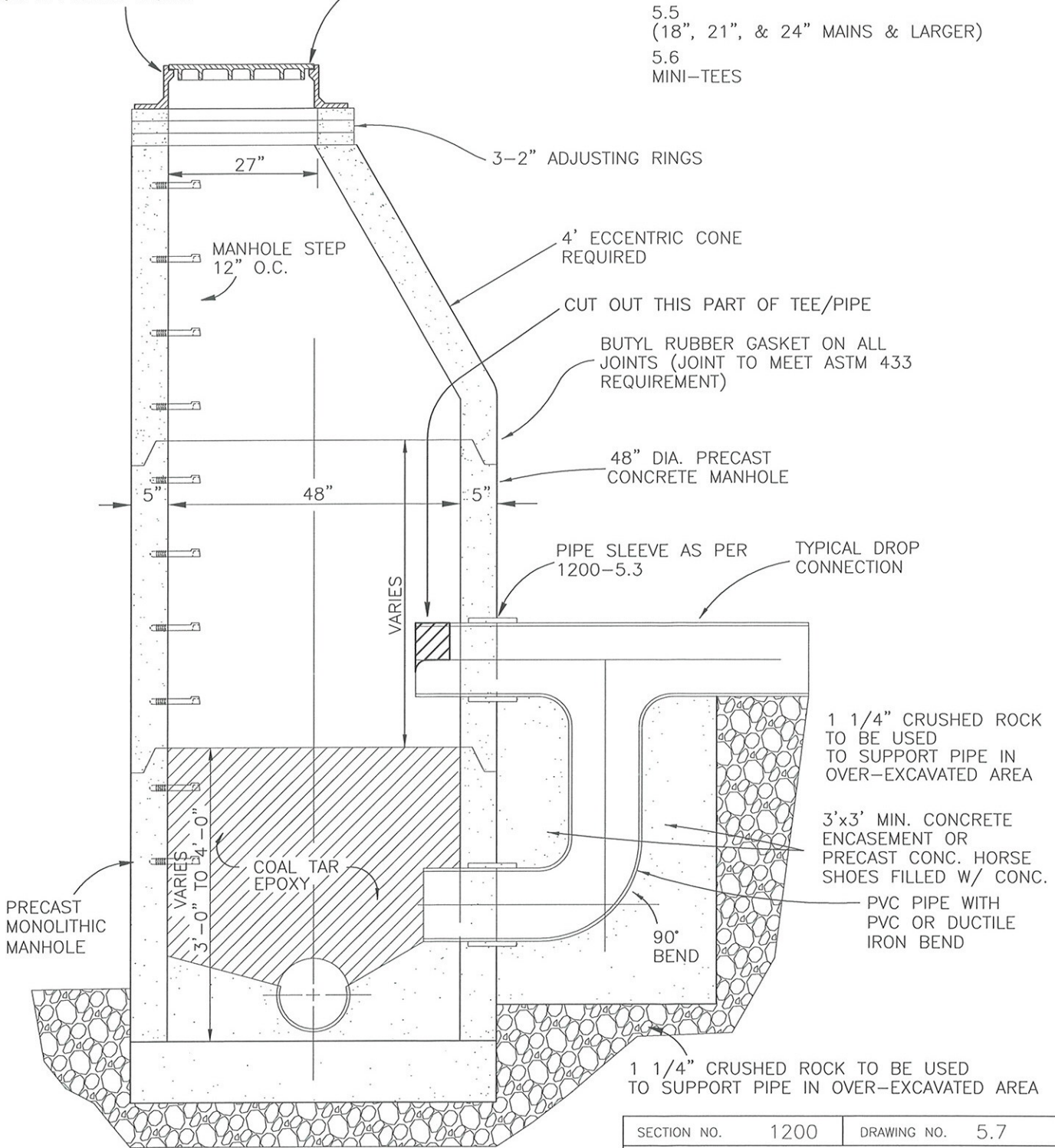

PRECAST  
 MONOLITHIC  
 MANHOLE

NOTE:  
 LIFT HOLES TO BE  
 MANUFACTURED  
 WATER PROOF

NOTE:  
 14-20 MILS OF COAL  
 TAR EPOXY OR APPROVED  
 EQUAL ON BOTTOM SECTION  
 OF MANHOLE

SECTION NO. 1200	DRAWING NO. 5.7
REV.D. 2013	
<b>SANITARY SEWER    MANHOLE (EXTERIOR    DROP CONNECTION)</b>	
CITY OF FARGO ENGINEERING DEPARTMENT	
APPROVED <i>ME</i>	DATE 1-2-13



CASTING FRAME & COVER  
 NEENAH FOUNDRY CO. R-1733  
 MUNICIPAL CASTINGS INC. 301-7/301A  
 EAST JORDEN 1205-AGSSA  
 OR APPROVED EQUAL

COVER SHALL HAVE  
 -CONCEALED PICK BAR  
 -"O" RING GASKET

NOTE:  
 INVERT AND LOWER MANHOLE SECTION  
 AS PER DETAILS:

5.4  
 (8", 10", 12" & 15" MAINS)

5.5  
 (18", 21" & 24" MAINS & LARGER)

5.6  
 MINI-TEE

NOTE:  
 THE INTERIOR DROP CONNECTION  
 AS SHOWN WILL ONLY BE USED  
 WITH THE EXPRESSED CONSENT  
 OF THE ENGINEER.

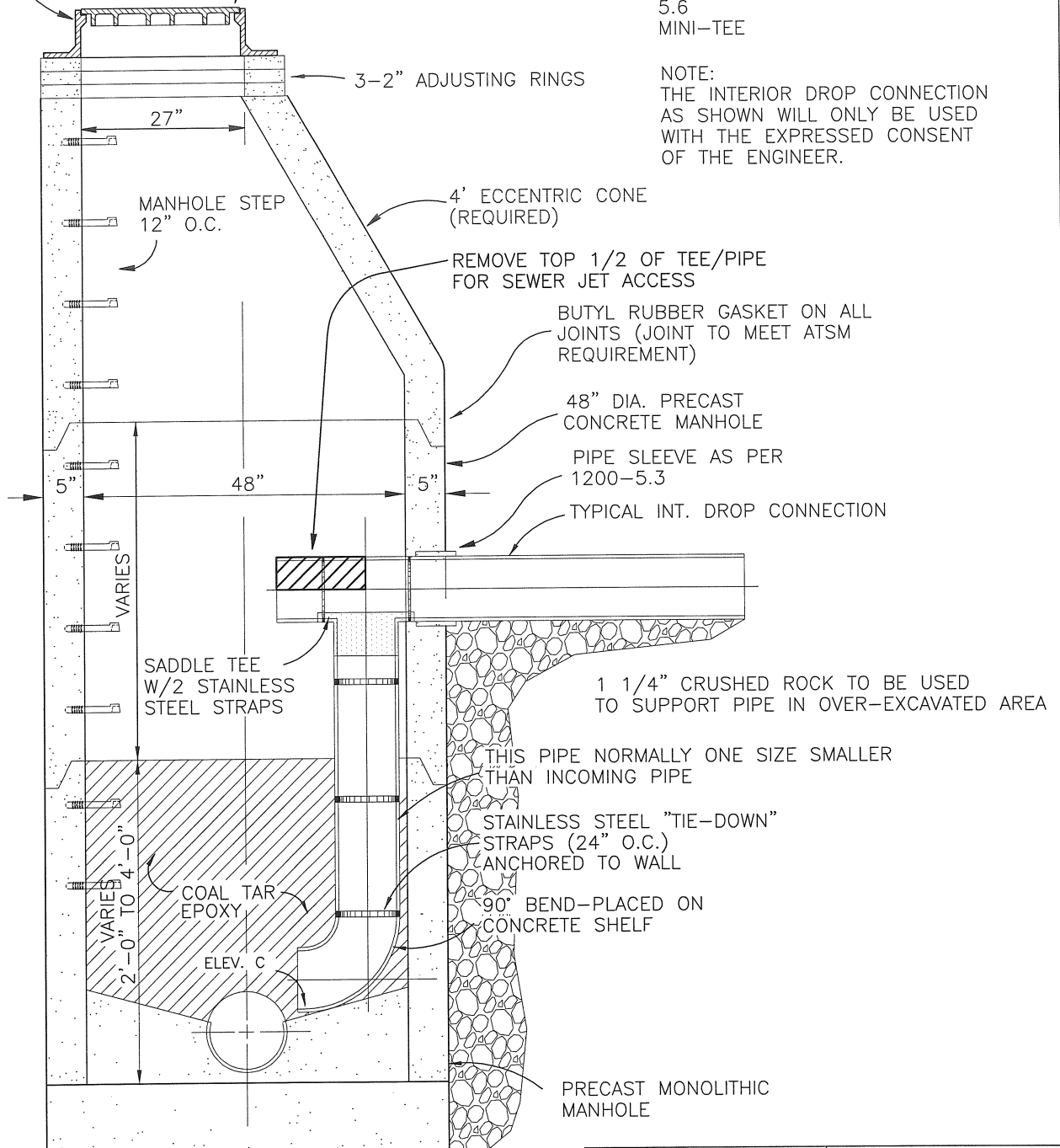

NOTE:  
 LIFT HOLES TO BE  
 MANUFACTURED  
 WATER PROOF

NOTE:  
 14-20 MILS OF COAL  
 TAR EPOXY OR APPROVED  
 EQUAL ON BOTTOM SECTION  
 OF MANHOLE

SECTION NO.	1200	DRAWING NO.	5.8
REV.D.	2012		
<b>SANITARY SEWER    MANHOLE (INTERIOR    DROP CONNECTION)</b>			
CITY OF FARGO ENGINEERING DEPARTMENT			
APPROVED	<i>BED</i>	DATE	<i>2-21-2012</i>

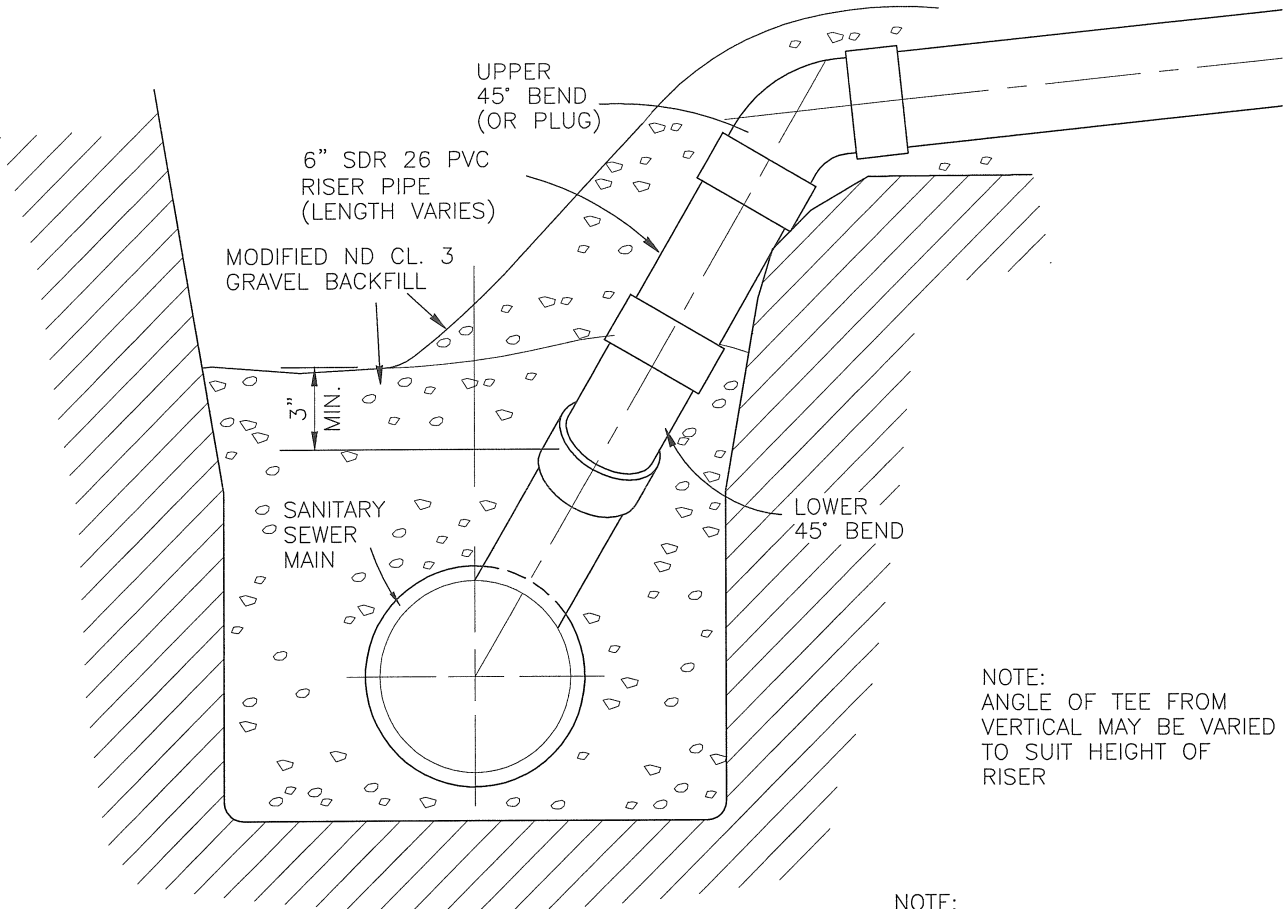

NOTE:  
 ANGLE OF TEE FROM  
 VERTICAL MAY BE VARIED  
 TO SUIT HEIGHT OF  
 RISER

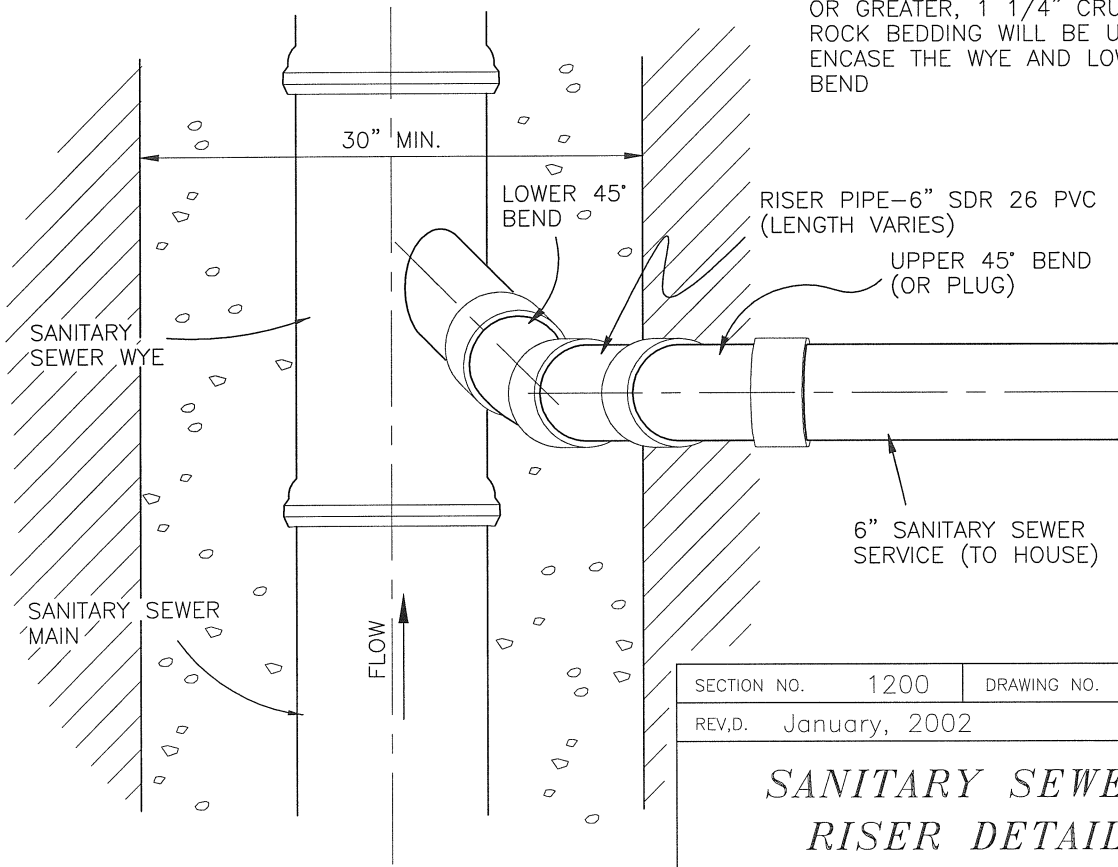

NOTE:  
 IF LENGTH OF RISER IS 5 FEET  
 OR GREATER, 1 1/4\"/>

SECTION NO.	1200	DRAWING NO.	5.9
REV.D.	January, 2002		
<b>SANITARY SEWER RISER DETAIL</b>			
CITY OF FARGO ENGINEERING DEPARTMENT			
APPROVED	<i>BED</i>	DATE	<i>2-21-2012</i>

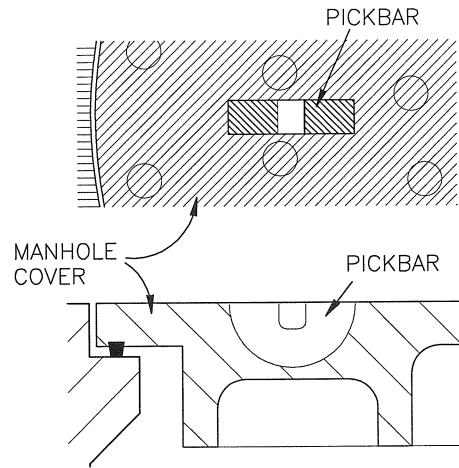
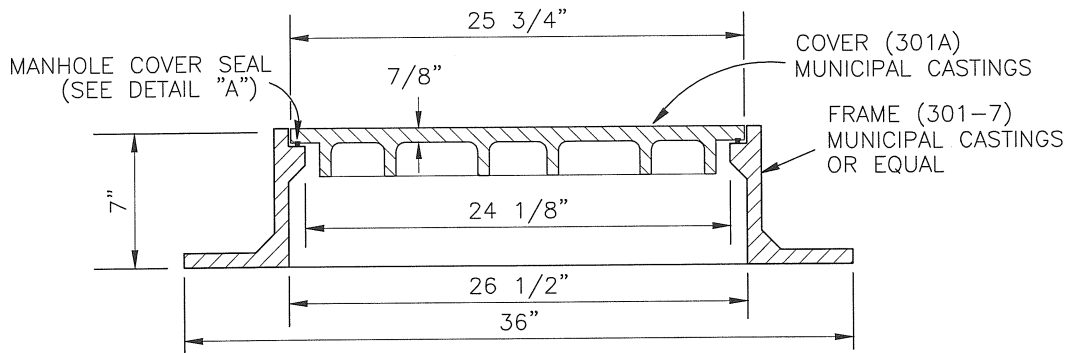
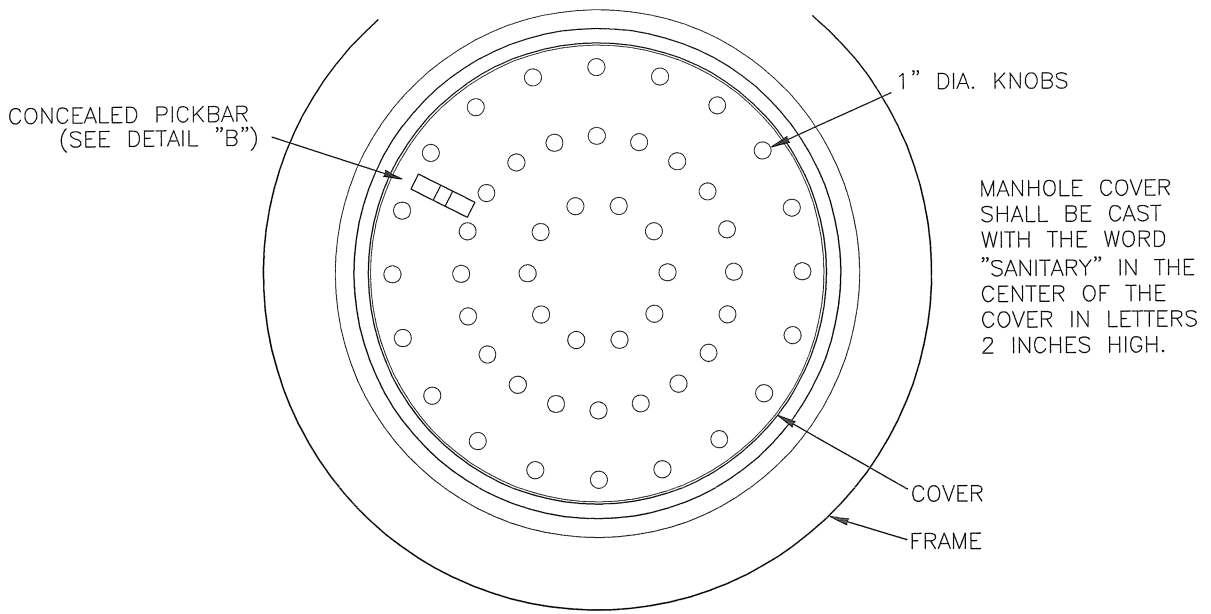

DETAIL "B"

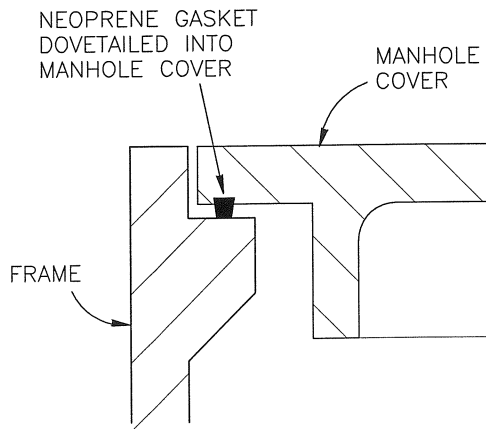

DETAIL "A"

SECTION NO.	1200	DRAWING NO.	5.10
REV.D.	2012		
<b>SANITARY MANHOLE COVER CASTING</b>			
CITY OF FARGO ENGINEERING DEPARTMENT			
APPROVED	<i>BED</i>	DATE	<i>2-21-2012</i>

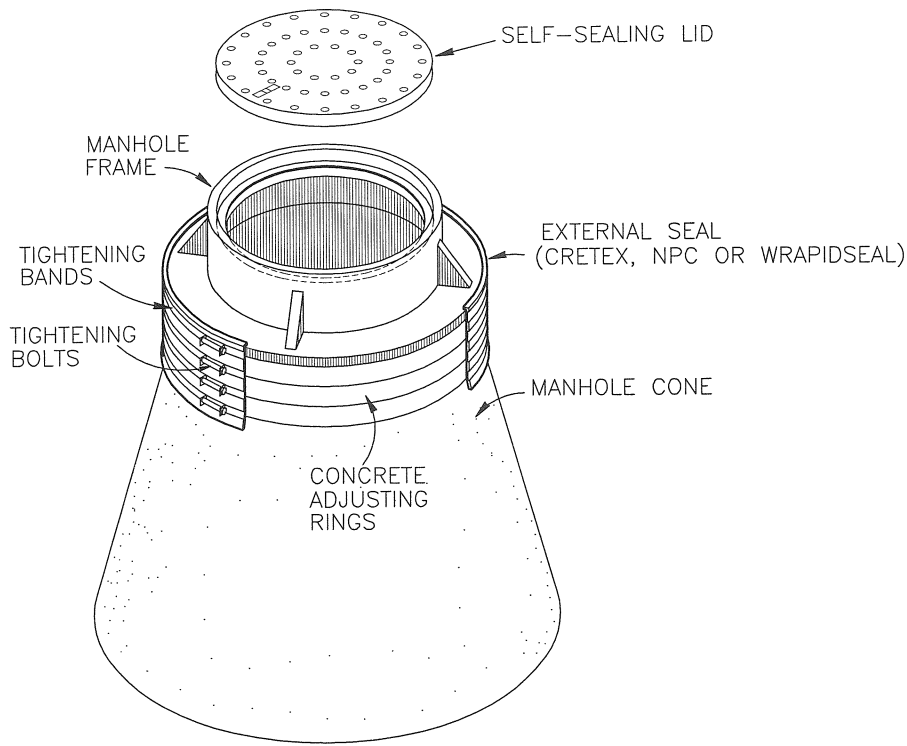

EXTERNAL MANHOLE SEAL

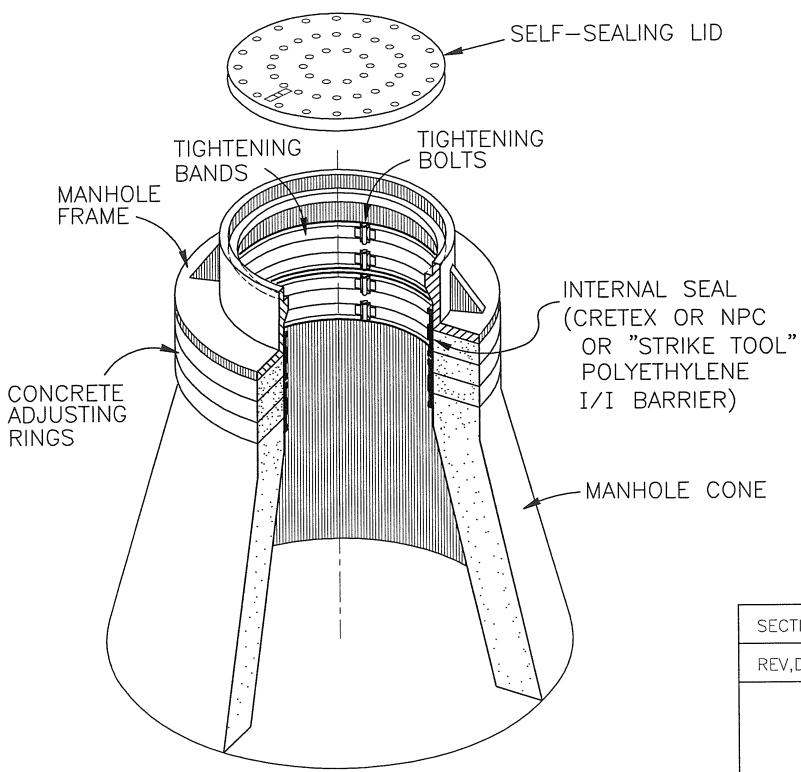

INTERNAL MANHOLE SEAL

SECTION NO.	1200	DRAWING NO.	5.11
REV.D.	March, 2007		
<b>MANHOLE SEALS DETAIL</b>			
CITY OF FARGO ENGINEERING DEPARTMENT			
APPROVED	<i>BED</i>	DATE	<i>2-21-2012</i>

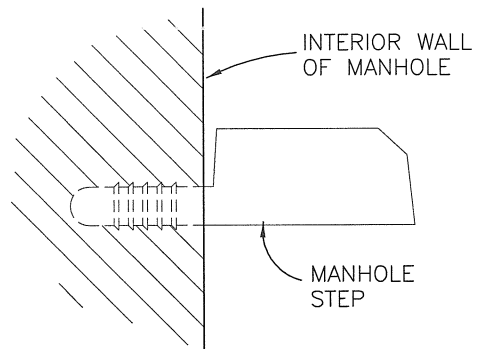
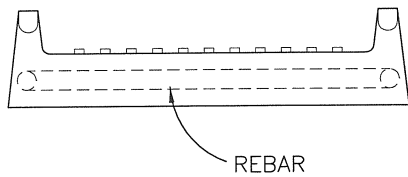
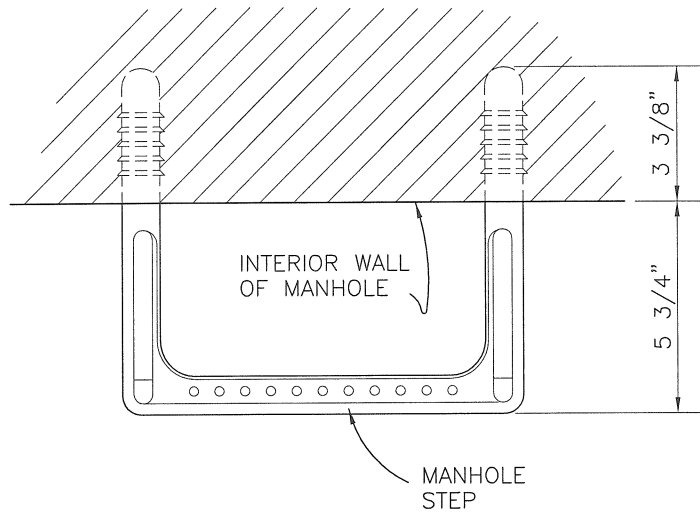

NOTE:  
 STEP SHALL BE CONSTRUCTED OF 1/2" REINFORCING ROD AND COMPLETELY ENCASED IN A CORROSION RESISTANT RUBBER OR POLYPROPYLENE PLASTIC, WHICH WILL RESIST DETERIORATION FROM HYDROGEN SULFIDE OR OTHER CHEMICALS AND GASES ENCOUNTERED IN MANHOLE APPLICATION. ALSO, STEP SHALL HAVE A VERTICAL RESISTANCE OF 400 LBS., AND A PULLOUT RESISTANCE OF 1000 LBS. SUCH AS: THE WEDG-LOC STEP BY DELTA PIPE PRODUCTS OR APPROVED EQUAL.

SECTION NO. 1200	DRAWING NO. 5.12
REV.D. March, 2000	
<b>MANHOLE STEP DETAIL</b>	
CITY OF FARGO ENGINEERING DEPARTMENT	
APPROVED <i>BEO</i>	DATE <i>2-21-2012</i>

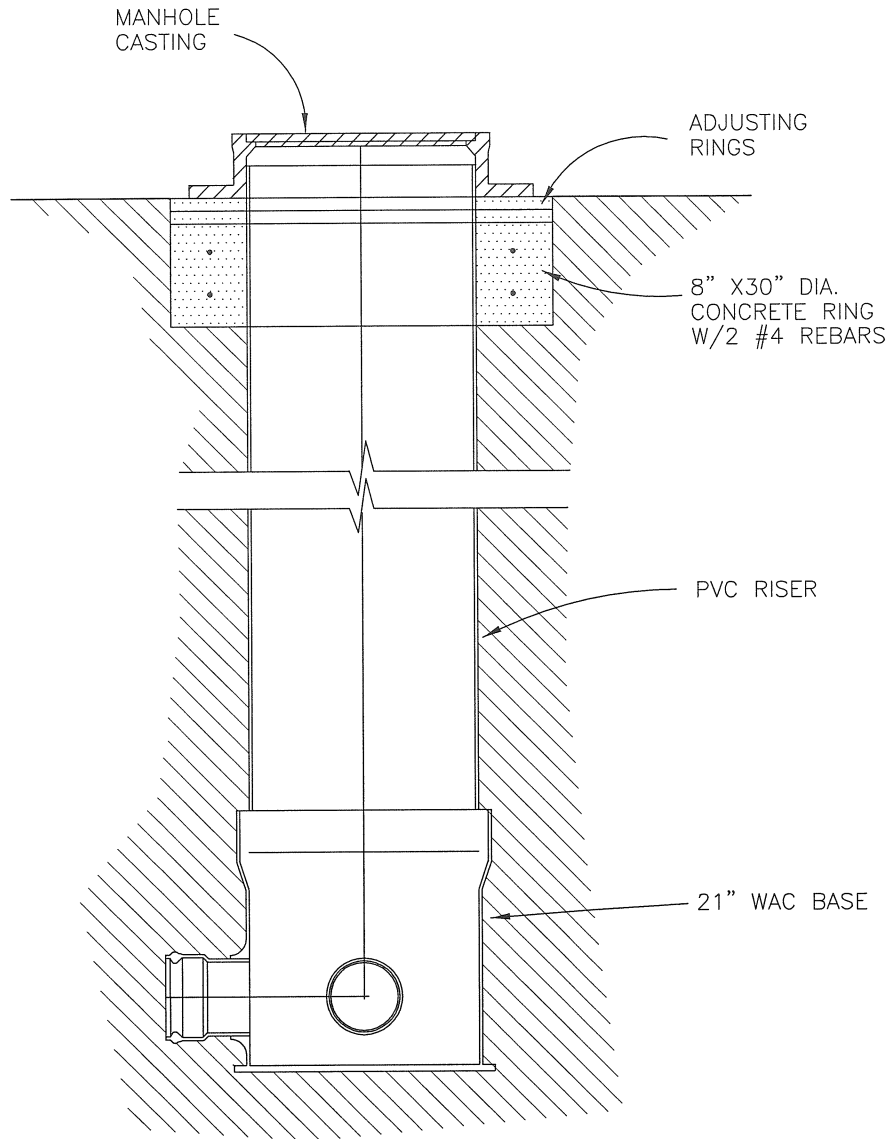

WAC MANHOLE DETAIL

SECTION NO. 1200	DRAWING NO. 5.13
REV.D. MARCH, 2000	
<i>STANDARD DETAIL WASTEWATER ACCESS CHAMBERS (WAC's)</i>	
CITY OF FARGO ENGINEERING DEPARTMENT	
APPROVED <i>BEO</i>	DATE <i>2-21-2012</i>

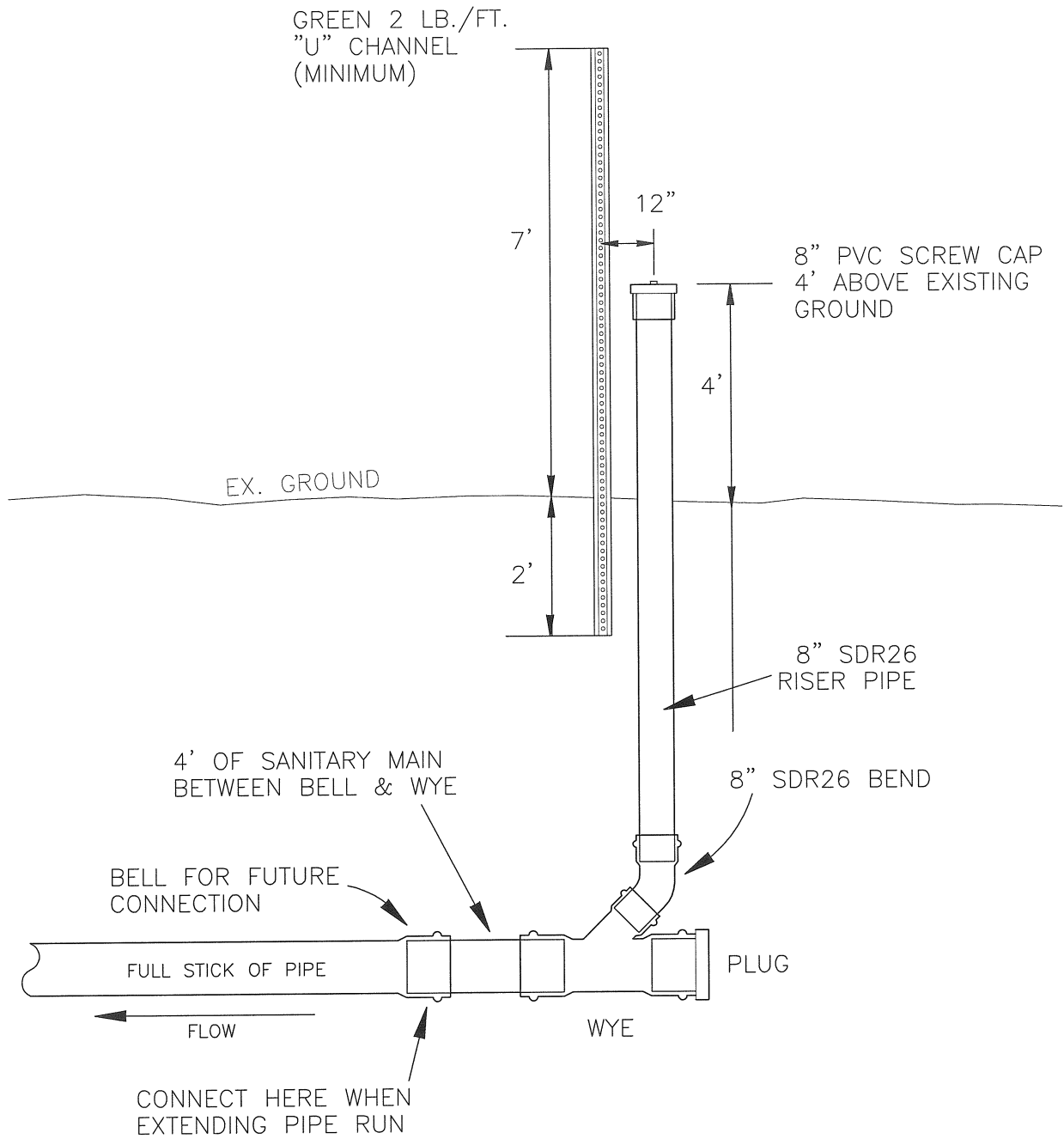

SECTION NO.	1200	DRAWING NO.	5.14
REV.D.	2012		
<b>SANITARY SEWER CLEANOUT DETAIL</b>			
CITY OF FARGO ENGINEERING DEPARTMENT			
APPROVED	BEO		DATE 2-21-2012

**CITY OF FARGO SPECIFICATIONS**  
**WATER MAINS**

**PART 1**  
**DESCRIPTION OF WORK**

The work to be done under this section of the Specifications and the accompanying plans consists of the furnishing of all labor, material, accessories and equipment necessary to construct water mains in the City of Fargo. The work includes excavation, furnishing, laying and jointing pipe; making connections to existing water mains as necessary; installing new valves, valve boxes, or valve manholes; installing hydrants; protecting existing utilities and public and private property; backfilling trenches and other work as may be necessary to in order that the work may be completed in accordance with these Specifications and the plans accompanying them.



**PART 2**  
**MATERIALS**

All products (treatment chemicals and material) that may come into contact with water intended for use in a public water system shall meet American National Standards Institute (ANSI)/National Sanitation Foundation (NSF) International Standards 60 & 61, as appropriate. A product will be considered as meeting these standards if so certified by NSF, The Underwriters Laboratories, or other organizations accredited by ANSI to test and certify such products.

2.1. POLYVINYLCHLORIDE (PVC) PRESSURE PIPE

*2.1.1. MATERIAL*

The PVC material shall conform to the requirements of ASTM D-1784, Class 12454-B.

*2.1.2. PIPE MANUFACTURE*

The pipe shall be marked to indicate compliance with NSF 61, Factory Mutual (FM) and be either marked or tagged with the Underwriter Laboratory (UL) approval. All PVC pressure pipe shall be manufactured in accordance with the latest revision of AWWA Standard C900. The pipe shall be DR 18.

*2.1.3. PIPE JOINTS*

PVC pipe joints shall be rubber gasketed conforming to the requirements of ASTM D-3139-98 or the latest revision.

2.2. DUCTILE IRON PIPE

*2.2.1. MATERIAL*

Ductile iron pipe shall conform to AWWA C-151 Standards.

*2.2.2. PIPE MANUFACTURE*

Ductile iron pipe shall be American made and conform to a Class 53 standard thickness class unless otherwise specified.

### 2.2.3. PIPE JOINTS

Ductile iron pipe joints shall be slip joints with rubber gaskets and meet AWWA C-111 Standards.

### 2.2.4. LINING

The ductile iron pipe shall be lined with cement mortar in accordance with AWWA C104. Cement for mortar shall be Portland Cement conforming to current ASTM specifications. The thickness of the lining shall not be less than the following:

1/16" for 3 to 12 inch pipe

3/32" for 14 to 24 inch pipe

1/8" for pipe larger than 30 inches

### 2.2.5. PIPE COATINGS

Ductile iron pipe shall be coated with a 1 mil asphaltic coating.

### 2.2.6. POLYETHYLENE WRAP

All ductile pipe shall be wrapped with polyethylene plastic film having a minimum thickness of 8 mils or with a cross woven polyethylene plastic film having a minimum thickness of 4 mils. All water service taps on ductile iron main shall be wrapped for a minimum distance of 3 feet from the water main.

### 2.3. FITTINGS

All fittings shall be PVC or Ductile Iron, and shall be “push-on” or “slip-joint” unless specified otherwise in the plans or special instructions to bidders. Cast iron fittings will be used only when approved by the Engineer.

#### *2.3.1. PVC FITTINGS*

PVC fittings shall be injection molded conforming to the requirements of AWWA C-907 and carry a working pressure of at least 150 psi. Molded fittings shall be made of PVC compound with a minimum hydrostatic design basis of 4,000 psi.

#### *2.3.2. DUCTILE IRON FITTINGS*

Ductile Iron fittings shall conform to AWWA C153, and shall be cement mortar lined on the interior and bituminous coated on the exterior. Cement lining shall conform to AWWA C104, and joints shall conform to AWWA C111. All ductile iron fittings shall be wrapped with polyethylene plastic film as specified for the ductile iron pipe, which must be securely fastened to the pipe on each side of the fitting. Mechanical joint fittings, where allowed by the Engineer, shall be bid complete with gaskets, glands, and stainless steel bolts.

#### *2.3.3. COUPLINGS*

All pipe couplings up to and including 12” in diameter shall be epoxy coated ductile iron meeting or exceeding the requirements of ASTM A 536, grade 65-45-12. Couplings shall meet the requirements of AWWA Standard C219. The coupling shall carry a minimum working pressure of 300 psi, having end rings that are segmented and joined with a pinless hinge, gaskets formed from virgin Nitrile Butadiene Rubber (NBR) compounded for water and sewer service in accordance with ASTM D2000, and 304 stainless steel armor. Fasteners shall be 304 stainless steel.

Couplings up to and including 12” in diameter shall be Romac Macro HP, Hymax DI High Pressure, or approved equal. Couplings larger than 12” shall be mechanical-joint long body sleeves meeting the requirements of AWWA C153.

### 2.4. GATE VALVES

*2.4.1. GENERAL*

Cast iron resilient-seated gate valves and tapping valves shall conform to the latest requirements of AWWA C509. Ductile iron resilient-seated gate valves and tapping valves shall conform to the latest requirements of AWWA C515. The valve seats shall be able to withstand 200 psi and the body shall withstand 400 psi.

*2.4.2. CONSTRUCTION*

Size:	4" to 36"
Joints:	Joints shall be provided with AWWA standard bell ends, flanged ends or mechanical joint bell ends as required for the type of pipe being used.
Gaskets:	Rubber.
Operation:	Open left (counter clockwise) w/ 2 inch operating nut.
Bolting:	All body bolts shall be stainless steel.
Stem & seals:	The stem shall be made of bronze and shall have two "O" rings to provide sealing.
Coating:	All valves shall be coated inside and out in accordance with the latest revision of AWWA C-550.

Acceptable manufacturers are American Flow, Clow, Mueller, U.S. Pipe or Waterous.

16" and larger valves shall be installed horizontally with bevel gear actuators.

*2.5. VALVE BOXES**2.5.1. GENERAL*

Valve boxes are required on all valves. All valve boxes shall be heavy-duty cast or ductile iron in accordance with ASTM A 48 30B material specification with a minimum tensile strength of 30,000 psi, have screw type adjustment, 5 1/4" shaft, and be furnished with heavy-duty cast or ductile iron bases and covers. Covers shall be made in the USA and cast with "WATER" on them. Valve boxes shall be three-piece type, adjustable from 62 to 82 inches in height, except that they shall in all cases be supplied and installed with a sufficient quantity of additional intermediate section(s) to allow the top of the installed box to be set at finished grade at mid-height of adjustment.

*2.5.2. VALVE BOX ADAPTOR*

Rubber valve box adaptors shall be installed for all valve boxes on all gate valves and butterfly valves. The adaptor shall be the Valve Box Adaptor II as manufactured by Adaptor, Inc. or as approved by the Engineer.

*2.6. TAPPING SLEEVES AND VALVES*

Valves shall be in accordance with the latest revision of AWWA C-509. The sleeves shall be mechanical joint with stainless steel bolts or stainless steel tapping sleeves with a stainless steel flange.

*2.7. HYDRANTS**2.7.1. GENERAL*

Hydrants shall be non-jacket types meeting the latest revision of AWWA C-502. All hydrants shall be equipped with a break-off traffic flange and shall be capable of being extended in 6" increments.

*2.7.2. CONSTRUCTION*

Main valve opening: 5" minimum.

Hydrant barrel: 7 3/8" minimum inside diameter.

Type of shut-off: Compression.

Inlet connection: 6" size- bell or mechanical joint type.

Nozzles: 2-2 1/2" hose nozzles; 1-4 1/2" pumper nozzle.

Nozzle threads: National Standard threads.

Bury depth: 8 feet 6 inches.

Operating & cap nuts: City of Fargo Standard (NST).

Direction to open: To the left (counter-clockwise).

Paint: City of Fargo Standard Red above ground line.

Bolts: All bolts below ground shall be stainless steel.

Hydrants shall be wrapped with polyethylene plastic film as per section 2.2.6.

*POLYETHYLENE WRAP.*

Acceptable manufacturers are Waterous WB67 Pacer and American Darling B62B-1.

2.8. HYDRANT MARKERS*2.8.1. GENERAL*

Hydrant markers shall be mounted on both sides of the post to face traffic (perpendicular to the curb) and shall be installed with each hydrant.

POST: Green U-channel- 2 lb. per foot & 9 feet long with 2 foot bury.

SIGN: 4" by 7" by 0.063" aluminum covered with Engineer Grade reflective sheeting, Red hydrant symbol on white background.

2.9. SERVICE CONNECTIONS

All service connections to PVC pipe shall be stainless steel, double bolt (minimum) service saddles. Service saddles shall have stainless steel washers between the nut and the plastic washer to equalize tightening stress. Rubber tapered gaskets shall be required to resist circumferential and longitudinal forces along with O-ring or flat gaskets for hydraulic seal. Saddle bolts shall be tightened to the manufacturers recommended tightness and verified with a torque wrench. Bolt tightness shall be rechecked with a torque wrench after the pipe tap is complete.

Approved saddle types:

Romac style 306

Ford style FS 300

Powerseal 3412AS

Cascade CSC2

2.10. YARD HYDRANTS*2.10.1. GENERAL*

Yard hydrants, where allowed by the Engineer, shall be brass ¾" frost proof type equipped with a brass vacuum breaker. The valve stem and plunger assembly shall be removable for inspection and repair without the need for digging up of the hydrant.

*2.10.2. CONSTRUCTION*

Hydrant barrel: 1" brass.

Inlet connection: ¾" NPT in brass casting.

Nozzle: heavy duty ¾" brass hose thread.

Bury depth: 7 feet.

Paint: Standard Red above ground line.

Acceptable manufacturers are Merrill Any Flow Brass Frost Proof or equal.

## 2.11. TRACER WIRE AND TRACER WIRE ACCESSORIES

### 2.11.1. GENERAL

All tracer wire and tracer wire accessories (connectors, splices, access points, and magnesium ground rods) shall be domestically manufactured in the USA. Tracer wire shall be installed along all water mains, water services, and sanitary sewer force mains unless otherwise noted in these plans. All system components, including tracer wire and tracer wire accessories must be compatible. Tracer wire and tracer wire accessories shall be considered incidental to other items.

### 2.11.2 TRACER WIRE

All tracer wire shall meet the following criteria:

- All tracer wire shall have HDPE insulation and color coded per APWA standards for specific utility being marked
- Must carry a radio signal to aid in locating buried underground utilities
- Certified to meet ASTM B170 specification for oxygen-free electrolytic copper
- Certified to meet ASTM B869 specification for 21% conductivity, hard drawn, copper-clad steel wire
- Certified to meet ASTM D1238 specification for polyethylene plastics extrusion materials
- The wire shall be identified by surface marking indicating manufacturer's identification, conductor size, and other appropriate information.

Tracer wire to be used for direct bury shall meet the following criteria:

- 12 AWG copper clad carbon steel core with HDPE coating (30 mil thickness) and minimum 450 lb. break load

Tracer wire to be used for directional drilling and boring shall meet the following criteria:

- 12 AWG copper clad carbon steel core with HDPE coating (45 mil thickness) and minimum 1,150 lb. break load

Tracer wire to be used for pipe bursting and slip lining shall meet the following criteria:

- 7 x 7 stranded copper clad steel with HDPE coating (50 mil thickness) and minimum 4,700 lb. break load

### 2.11.3 *TRACER WIRE CONNECTORS*

Tracer wire connectors shall be used to interconnect tracer wire at the intersection of mains and laterals. Non-locking, friction fit, twist on wire nuts, or taped connectors are prohibited.

Tracer wire connectors to be used for direct bury, directional drilling, and boring shall meet the following criteria:

- Pre-filled with dielectric silicon that never hardens.
- Waterproof and corrosion proof.
- Manufactured for the wire gauge being installed.
- Designed for direct bury and low voltage up to 50V.

Connectors used for direct bury, directional drilling, and boring shall be “DryConn Direct Bury Lug Aqua”, “Copperhead Mainline to Service Connector”, or approved equal.

Tracer wire connectors to be used for pipe bursting and slip lining shall meet the following criteria:

- ¼”- 20 slotted stainless steel set screw with 30 volt maximum and shall be protected from corrosion with a wax pad or other approved anti-corrosive methods.

Connectors used for pipe bursting and slip lining shall be “SnakeBite Pipe Burst Connector” or approved equal.

### 2.11.4 *TRACER WIRE SPLICES*

Tracer wire splices shall be used to join tracer wires at the end of a spool or when required to repair damaged tracer wire. End of spool tracer wire splices shall occur no more than once per 500 feet.



Tracer wire splices to be used for direct bury, directional drilling, and boring shall be “DryConn Direct Bury Lug Aqua”, “Copperhead Mainline to Service Connector”, “Copperhead SnakeBite Locking Connector”, or approved equal.

Tracer wire connectors to be used for pipe bursting and slip lining shall meet the following criteria:

- In-line splices for the 7x7 copper clad steel core tracer wire shall be made with a 30 volt maximum solid brass lug with a set screw locking mechanism. The brass lug shall be protected with a fast cure heat shrink that creates a weather resistant connection.

#### 2.11.5 ACCESS POINTS

Tracer wire access points shall be “Copperhead Cobra Access Point”, “Rhino TriView Test Station”, or approved equal.

Tracer wire access points installed at hydrant locations shall meet the following criteria:

- Made of polypropylene material
- Direct connection point for utility locator transmitter
- Minimum of 2 terminal exterior connection points with a jumper
- Tracer wire protection conduit connection opening at the bottom with 1” MTP thread
- Blue in color

Tracer wire access points installed at hydrant locations shall be “Copperhead Cobra Access Point” or approved equal.

The mounting bracket for connecting tracer wire access points to a hydrant shall be either a ¾” HDPE flange or a stainless steel flange. To protect tracer wire from weed whips, mowers, etc., tracer wire shall be run through a tracer wire protection conduit. The tracer wire protection conduit shall be a minimum 2-foot long piece of 1” HDPE heavy-wall innerduct with MTP thread on the connection end and an angle-cut buried end.

Tracer wire access points installed at locations other than hydrants or curb stops shall meet the following criteria:

- Temperature stable from -40 degrees Fahrenheit to +150 degrees Fahrenheit
- Color coded per APWA standards for specific utility being marked

- Shall be 54” in length
- Shall have tracer wire terminal post
- Must have a minimum of 2 external terminals ¼” brass shall include a bolt, nut, washers and ring terminal
- TS-SHUNT/ Jumper between the two adjacent terminals shall be rust free
- Mounted to a “T” post or “U” Channel

Tracer wire access points installed at locations other than hydrants shall be “Rhino TriView Test Station” or approved equal.

#### *2.11.6 MAGNESIUM GROUND ROD*

Magnesium ground rods shall meet the following criteria:

- Shall be a 1.5 lb. drive-in magnesium ground rod
- HDPE cap mounted to top of rod
- Minimum of 12 foot factory installed 12 AWG copper clad carbon steel core tracer wire
- Magnesium ground rod tracer wire shall be 12 AWG copper clad carbon steel core with HDPE coating (30 mil thickness) and minimum 450 lb. break load
- Magnesium ground rod tracer wire coating shall be red in color

#### 2.12. INSULATION

Insulation shall be in accordance with Section 1200 of these Specifications.

**PART 3**  
**CONSTRUCTION**

3.1. GENERAL

Excavation, trenching, and backfill shall be done in accordance with Section 1000. Pipe and fittings shall be handled and laid in accordance with the latest revision of AWWA Standard C600. Pipe and fittings shall be laid in the location shown on the plans, the exact location being designated by the Engineer during construction. Before laying any pipe, it shall be cleaned of all foreign matter and kept clean thereafter. Open ends shall be protected at all times to prevent the entrance of dirt, trench water, animals or foreign material into the pipe. The bell and spigot shall be wiped clean and sufficient lubrication placed on the gasket and spigot before the pipe is pushed fully into the bell. Field cut spigot ends of push-on joints shall be beveled prior to being pushed into the bell. Every part of the pipe shall be bedded uniformly throughout its length. All handling, field cuts, polyethylene wrapping, and jointing shall be done as per the manufacturer's recommendation.

3.2. ALIGNMENT

The Engineering Department will provide line and grade for all water main. All water mains shall have a minimum cover of 7.5'. Grade shall be maintained by the Contractor using methods approved by the Engineer. Water mains installed parallel to sanitary sewer shall be laid 10 feet apart, distance shall be measured edge to edge. Where a water main crosses a sanitary sewer line, a minimum vertical distance of 18 inches shall be maintained between the outside of the water main and the outside of the sewer. Deflections from a straight line or grade, where permitted by the Engineer, shall not exceed the pipe manufacturer's recommendation.

3.3. THRUST BLOCKS

All fittings shall be braced by means of poured concrete or concrete thrust blocks. No wood thrust blocks will be allowed. Poured concrete shall be 3000 psi concrete poured against undisturbed earth. Care shall be taken not to cover up joints, bolts, flanges, and the fittings with concrete.

Thrust restraint at the joints may be used in lieu of concrete thrust blocking with the permission of the Engineer. Restraint devices for PVC pipe shall meet or exceed the requirements of ASTM F 1674-96 or the latest revision, Standard Test Method for Joint Restraint Products for Use with PVC Pipe.

### 3.4. SETTING HYDRANTS

All hydrants shall be vertically plumb and shall have their pumper nozzle facing and at right angles to the street. Each hydrant shall be set on a concrete block and blocked behind with concrete block(s) of sufficient size to prevent settling and horizontal movement. Hydrant bases shall be backfilled with at least 1/3 cubic yard of 1 1/4" crushed rock to facilitate drainage and covered with polyethylene plastic film. The 1 1/4" crushed rock shall extend to 6" above the weep hole. After backfilling the hydrant markers shall be installed 18 inches behind the hydrant.

### 3.5. CONNECTIONS TO EXISTING WATER MAINS

Connections between new and existing pipes shall use proper specials and fittings to suit the actual conditions encountered. Suitable facilities shall be provided for proper de-watering, drainage, and disposal of all water removed from the excavation or pipe without damage to adjacent property. Prior to the closure of existing water mains, the Contractor shall notify all affected water users.

### 3.6. WATER MAIN SHUTDOWNS

The Contractor shall coordinate water main shutdowns with the Engineer and the Mains and Hydrants Department. The Contractor is responsible for gate valve locations and property notification. The Mains and Hydrants Department will assist with cleaning and operating the valves if required.

Shutdowns in residential areas may not occur prior to 9:00 AM. Residential water users shall be notified of the outage by 7:00 PM the night before the planned shutdown.

The Contractor shall schedule outages to non-residential water users in such a manner as to minimize the impact of the outage to the user. Outage notifications to non-residential water users shall be per the direction of the Engineer, but in no case shall be given less than 2 working days prior to the shutdown.

Notifications shall be in writing and shall indicate the estimated duration of the shutdown. A sample shutoff notification form can be found on the City's website. If actual shutdown varies from the stated time by more than one hour, a second verbal notification is required.

The Contractor shall turn on all valves after the necessary water main connections have been made.

### 3.7. TEMPORARY WATER SERVICES

If the water to a property is to be out for more than 12 hours, the Contractor will be responsible for providing a temporary water service to the affected water users. All piping shall be rated for potable water use. Minimum pipe size shall be 1" diameter for up to 3 service connections, 2" diameter for 4 or more connections. The Contractor shall use larger pipes where necessary to provide adequate domestic service throughout the duration of the temporary connection. Valves shall be provided on temporary piping at intervals not to exceed 500 feet. The method of providing the temporary water service (which hydrant to use, direction to feed, etc.) shall be an option of the Contractor subject to the approval of the Engineer.

All temporary water mains and services shall be disinfected in accordance with section 1300.3.9. One water sample per block at the end of a service connection will be taken after the temporary water line is flushed. The sample shall show the absence of bacteria before connections are allowed. All mains and services shall be flushed prior to being put into service. No additional contract time will be allowed for failure to pass bacteria test.

### 3.8. SETTING VALVES

Valves will be installed where shown on the plans or as directed by the Engineer. Before installing the valve, care should be taken to ensure that all foreign material has been removed. The stuffing boxes shall be tightened and the valve opened and closed to see that all parts are in first class working order. Valves shall be set on block as shown in the details. The body of the valve shall be wrapped with polyethylene wrap, securely fastened to the pipe on both sides of the valve, as per ANSI/AWWA C105/A21.5. Valve and valve boxes must be plumb. The valve box adapter shall be installed on the valve and the valve box shall be placed directly over the operating nut, and the top of the box being brought flush with finish grade. The Valve box shall be wrapped with polyethylene plastic film as per section 2.2.6. *POLYETHYLENE WRAP*. The box shall be backfilled and thoroughly tamped around the box. After backfilling a wrench shall be dropped on the valve to ensure that it is operable. Prior to acceptance, the City Water Department will verify that each valve is easily operable.

### 3.9. DISINFECTION

All water mains shall be chlorinated as set forth by the latest revision of AWWA Standard C651. Sufficient chlorine tablets or powder shall be placed in each pipe to furnish a resultant solution of

50 to 100 parts per million of available chlorine. Generally required dosage to meet this standard is as follows:

<u>WATER MAIN SIZE</u>	<u>REQUIRED DOSAGE</u>
2"	1 LB. PER 10,000 FEET
4"	1 LB. PER 2,500 FEET
6"	1 LB. PER 1,100 FEET
8"	1 LB. PER 700 FEET
10"	1 LB. PER 350 FEET
12"	1 LB. PER 280 FEET
16"	1 LB. PER 160 FEET

The chlorinated water shall remain in the pipe line for at least 24 hours and shall have a residual chlorine content of at least 5 parts per million at that time. A bacteriological sample will be taken after the main is flushed and shall show the absence of bacteria before connections are allowed to the water main. Chlorine disinfection shall be included in the unit bid price for the pipe.

### 3.10. PRESSURE AND LEAKAGE TESTING

All water main and services shall be subjected to pressure and leakage testing. All services shall be pressure tested with the main. The Contractor shall furnish all pumping equipment, labor and gauges required for these tests and if any section of pipe does not meet these tests, the Contractor shall at his own expense locate and repair the defects and retest the line until it meets the requirements. The pipe shall be subjected to a hydrostatic test of 150 psi for a period of two hours. Each pressure test shall be limited to a maximum of 1,500 linear feet of water main. The pressure shall be held within 2 psi of this test pressure for the entire time and leakage shall not exceed the rate established by the following formula:

$$Q = (LD\sqrt{P})/148,000$$

In which:

Q= maximum permissible leakage rate in gallons per hour for the length of line being tested.

L= length of the line being tested in feet.

D= internal diameter of the pipe in inches.

P= average test pressure in psig.

In the event that the line contains more than one size of pipe, the allowable leakage for each size shall be calculated separately and then added to obtain the total allowable leakage allowed for the

lines being tested. Repairs shall be made by replacing the defective pipe or dismantling the faulty joint, cleaning, realigning the gland or gasket and reassembling the joint as per the original specification. Repair sleeves may only be used if approved by the Engineer and shall have all stainless steel parts. All cost of locating and repairing the leaks shall be borne by the Contractor.

### 3.11. BACTERIOLOGICAL TESTING

Bacteriological testing is required on all new and replaced water main before the water main is placed in service. The tests ensure that the water being introduced into the system has been properly disinfected and is free of contamination. Only the City inspector may do the testing procedure. Records are kept of the litmus test, the bacteriological tests, and the chain of custody during the sample submittal process.

All water samples for bacteriological testing shall be collected from a newly installed water service. If a project does not include newly installed water services, the Contractor shall supply all labor and materials necessary to collect the sample. The materials, location, and method for abandonment/removal of necessary materials shall be approved by the Engineer. Water samples may not be collected from a fire hydrant.

After final flushing and before the new water main is connected to the distribution system, two consecutive sets of acceptable samples, taken at least 24 hours apart, shall be collected from the new main. At least one set of samples shall be collected from every 1,200 feet of new water main. All samples shall be tested for bacteriological quality in accordance with *Standard Methods for the Examination of Water and Wastewater*, and show the absence of coliform organisms and the presence of a chlorine residual.

The basic procedure is as follows:

1. Insert litmus paper test strip in the discharge stream of the hydrant while it is being flushed. The color change will indicate that there is residual chlorine content.
2. Before the valves are opened, obtain a sterile sample of the disinfected main. This water sample will be taken after the completion of the pressure test. 100-ml samples will be taken with a chlorine neutralizer tablet in the container. The sample must be taken to the water plant immediately for testing. If this is not possible, the sample must be kept in a refrigerated container, however, the test must begin within 24 hours. Results will be available approximately 24 hours from the time the test is admitted.

3. A second sample is obtained from the same location at least 24 hours after the first sample. This sample indicates that the residual chlorine content is such that verification is obtained that the pipe, newly introduced water, and any debris are disinfected. As such, the sample must be obtained from water that has remained in the new pipe for at least 24 hours. Both samples must pass the test before the new water main may be opened and put in use in the distribution system.
4. When flushing the mains, care must be taken to ensure that flow is away from the existing mains. This may involve flushing ½ block in one direction until the water is clear, and then closing that valve and flushing from the other end of the block for a mid-block hydrant.

If the initial disinfecting fails to produce satisfactory results, the main shall be reflushed and re-sampled. If check samples also fail, the main shall be rechlorinated by the continuous feed or slug method until satisfactory results are obtained.

The Contractor should note that the testing tank may require sterilization in order to avoid contamination of the mains during the testing process. The pipe installation crews will need to ensure that the pipes are free of dirt, debris and other matter. It must be remembered that the final water quality test is not the primary means for certifying the sanitary condition of the main. The sanitary handling of materials, the construction practices, and the continual inspection of the work are the primary means for ensuring the sanitary condition of the water main.

The Contractor shall assist the inspector as necessary to obtain the samples. All costs for the disinfection and testing of water mains shall be incidental to the bid price for the water main.

### 3.12. TRACER WIRE SYSTEM

#### *3.12.1. GENERAL*

Tracer wire shall be installed below the spring line of pipes and fittings. Tracer wire shall be securely fastened to the water main pipe with tape or plastic ties at every pipe bell or at 20 foot intervals, whichever is less. In addition, tracer wire shall be secured within 1 foot of all underground utility appurtenances. The maximum mainline spacing for a tracer wire access point shall be no greater than 600 linear feet. End of spool tracer wire splices shall occur no more than once per 500 feet. All lateral tracer wires shall be a single wire, connected to the mainline tracer wire using an approved tracer wire connector. Looping or coiling of wire is not allowed.



Minimum requirements for the number of tracer wire lines are as follows:

- One wire shall be used for direct bury installations
- Two wires shall be used for directional drilling/ boring installations
- One 7x7 extreme strength copper clad steel core tracer wire shall be used for pipe bursting/ slip lining installations.

Any damage occurring during installation of the trace wire must be immediately repaired by removing the damaged wire and installing a new section of wire with approved connectors and/or splicing kits. Taping and/or spray coating is not allowed. Mainline trace wire shall not be connected to existing conductive pipes.

All costs associated with the installation and testing of the tracer wire shall be considered incidental to other items.

#### *3.12.2. TRACER WIRE CONNECTORS*

Tracer wire connectors shall be used to interconnect tracer wire at the intersection of mains and laterals. Tracer wire connectors shall be installed in accordance with the manufacturer's installation instructions. The mainline tracer wire shall not be cut.

#### *3.12.3. TRACER WIRE SPLICES*

Tracer wire splices shall be used to join tracer wire at the end of a spool or when required to repair damaged tracer wire. End of spool tracer wire splices shall occur no more than once per 500 feet.

#### *3.12.4. TRACER WIRE ACCESS POINT*

At each hydrant, the tracer wire and the magnesium ground rod tracer wire shall be routed up the side of the hydrant, through the tracer wire protection conduit, and connected to the access point. The Contractor shall leave 2 feet of tracer wire and magnesium ground tracer wire slack in the tracer wire protection conduit.

At locations other than hydrants or curb stops, tracer wire and the magnesium ground rod tracer wire shall be ran into a "Rhino TriView Test Station" or approved equal access point. The access point shall be mounted to a "U" channel post. The Contractor shall leave 2 feet of tracer wire and magnesium ground tracer wire slack in the "Rhino TriView Test Station" or approved equal access point.

Tracer wire shall not be mounted to the lid of gate valves or other devices that are located within the pavement section.

*3.12.5. TRACER WIRE MAGNESIUM GROUND RODS*

Tracer wire must be properly grounded at all hydrants. Grounding of trace wire shall be achieved by use of a drive-in magnesium ground rod specifically manufactured for this purpose and shall be driven into virgin ground below the pipe bedding. The lateral tracer wire and the magnesium ground rod tracer wire shall be ran up the hydrant through the tracer wire protection conduit and connected to the access point. The Contractor shall leave 2 feet of tracer wire and magnesium ground rod tracer wire slack in the tracer wire protection conduit.

*3.12.6. TRACER WIRE ELECTRICAL CONDUCTIVITY TEST*

All new tracer wire installations shall be located using typical low frequency (512Hz) line tracing equipment furnished by the Contractor and witnessed by the Contractor and Engineer prior to acceptance of ownership.

This verification shall be performed upon completion of rough grading and again prior to final acceptance of the project.

Continuity testing in lieu of actual line tracing shall not be accepted. All areas failing the location test shall be corrected at the Contractor's expense. The wire shall be tested in accordance with the requirements of ASTM B-1, B-3, B-8 and D-1248.

*3.12.7. ELECTRICAL CONDUCTIVITY TEST FOR DUCTILE IRON*

The Contractor shall perform a conductivity test one week after completion of pressure testing of the water main on all ductile iron pipe water main. This shall be performed in a timely manner to ensure acceptable conductivity prior to further construction.

On water main reconstruction projects, the Contractor shall perform the conductivity test prior to service line reconnections to ensure main line isolation from house services.

The Engineer and Owner may require a Contractor to test the first section of pipe installed to demonstrate the Contractor's ability to install the pipe in an acceptable manner. When the connection to the existing system is not made with a valve, the Contractor shall test the existing section to the first available valve(s) to determine the condition of the existing system, or the Contractor may make provisions to test his work separately, prior to connection to the existing system, in a manner acceptable to the Engineer.

The system (pipeline, valves, fittings and hydrants) shall be tested for electrical continuity and current capacity. The electrical test shall be made after the hydrostatic test and while the line is at normal operating pressure. Backfilling shall have been completed. The line may be tested in sections of convenient length as approved by Engineer.

Direct current of 350 amperes plus or minus 10%, shall be passed through the pipeline for 5 minutes. Current flow through the pipe shall be measured continuously on a suitable ammeter and shall remain steady without interruption or fluctuation throughout the 5-minute test period.

Insufficient current or intermittent current or arcing, indicated by large fluctuation of the ammeter needle, shall be evidence of defective contact in the pipeline. The cause shall be isolated and corrected. Thereafter, the section in which the defective test occurred shall be retested as a unit and shall meet the requirements.

Sources of D.C. for these tests may be motor generators, arc welding machines, or other approved sources. All such equipment shall be furnished by the Contractor.

Cables from the power source to the section of system under test should be a sufficient size to carry the test current without overheating or excessive voltage drop.

After the test, the hydrant shall be shut off and cap loosened to allow hydrant drainage. Tighten cap after drainage.

3.13. FINAL INSPECTION

The Contractor and the City of Fargo representative will operate all main valves and inspect all stop boxes for access. This procedure will be accomplished after all clean up, etc. has been completed. This inspection will be made prior to the final payment for work performed. Any defects shall be promptly repaired by the Contractor at his cost.

**PART 4**  
**GUARANTEE, MEASUREMENT & PAYMENT**

4.1. GUARANTEE

The guarantee shall be per the contract.

4.2. MEASUREMENT AND PAYMENT

*4.2.1. GENERAL*

The cost of excavation, trenching, and backfill shall be included as part of this specification.

*4.2.2. WATER MAIN PIPE*

Pipe will be measured by customary and conventional methods and paid for on a unit price basis for the actual length installed.

Measurement will be from the center of the fitting or valve to the center of the next fitting or valve. The unit price shall include the cost of the pipe, jointing material, tracer wire and tracer wire accessories, concrete thrust blocking or joint restraint and all other appurtenance costs except valves, hydrants, and fittings, completely installed in accordance with the Specifications.

*4.2.3. FITTINGS*

Unless otherwise noted on the plans, water main fittings will be measured by the pound without joint accessories or cement lining. The weight for fittings not listed in the tables below shall be in accordance with AWWA C153. The weight for fittings not listed in the tables below or in AWWA C153 shall be the actual weight of the fitting(s) furnished and installed based on acceptable documentation provided by the Contractor. The standard weight of water main fittings, for payment purposes, shall be as follows:

Bends, Caps, and Plugs							
Size	Fitting Weights, lbs. (AWWA C153)						
	Bends (degrees)				Caps	Plugs	Sleeves
	90	45	22.5	11.25			
4	25	22	18	16	9	10	20
6	39	32	31	30	15	16	29
8	57	46	46	42	22	26	45
10	89	70	64	58	32	36	61
12	108	86	80	67	42	46	76
14	210	160	136	93	66	75	128
16	264	202	172	148	92	95	159
20	400	305	310	245	125	135	236
24	565	405	412	315	166	175	306

Tees, Crosses, and Reducers									
Run	Branch	Fitting Weights, lbs. (AWWA C153)			Run	Branch	Fitting Weights, lbs. (AWWA C153)		
		Tee	Cross	Reducer			Tee	Cross	Reducer
Large	Small				Large	Small			
4	4	32	40		16	6	228	240	124
6	4	46	57	24	16	8	248	260	124
6	6	56	75		16	10	264	317	124
8	4	60	68	32	16	12	280	306	112
8	6	72	74	36	16	14	316		140
8	8	86	105		16	16	322	385	
10	4	78	112	46	20	6	315		
10	6	90	119	47	20	8	345	379	
10	8	105	124	50	20	10	370		220
10	10	120	145		20	12	395	413	205
12	4	94	119	58	20	14	440		200
12	6	110	126	58	20	16	465		200
12	8	125	149	57	20	20	535		
12	10	140	179	61	24	6	415		
12	12	160	213		24	8	445	481	
14	4	172			24	10	470		
14	6	182	200	100	24	12	500	529	305
14	8	206	228	100	24	14	550		306
14	10	228		100	24	16	580	576	320
14	12	234		100	24	20	660	1589	300
14	14	280	299		24	24	720		

#### 4.2.4. VALVES

Valves will be paid for under the unit price bid per each complete in place. The unit price will include the valve, jointing material, valve box, valve box adaptor, concrete blocking, necessary extensions, and all other work necessary for a complete and workable valve installation.

#### 4.2.5. HYDRANTS AND YARD HYDRANTS

Hydrants will be paid for under the unit price bid per each complete in place. The unit price will include the hydrant with hydrant marker, rock bedding, blocking, excess excavation and all other work necessary for a complete and workable hydrant installation.

#### 4.2.6. POLYETHYLENE WRAP

Polyethylene wrap shall be included in the unit bid price for ductile iron pipe, fittings, hydrants, and valves. All material, labor, equipment and incidental costs necessary to install the plastic wrap shall be included.

#### 4.2.7. DISINFECTION AND TESTING WATER MAINS

Disinfection and testing of water mains shall be incidental to the bid price for the water main. Payment will not be made for water main until such time as it has been successfully tested.

#### 4.2.8. TAPPING SLEEVES AND VALVES

The unit bid price shall include the cost of furnishing and installing the tapping sleeve and valve. The City of Fargo Water Department will make the tap for 12" and smaller taps. On taps larger than 12", the Contractor shall make arrangements with other entities to make the tap. For connections made to the water main that are not made under city contract the Contractor will be billed for the connection by the City Water Department.

#### 4.2.9. TRACER WIRE

The tracer wire system and electrical conductivity testing shall be considered incidental to water main construction.

*4.2.10. OTHER COSTS*

All other costs for work necessary to properly complete the work specified herein shall not be bid items; the costs shall be charged to other items unless a bid item is specifically included on the bid sheet.



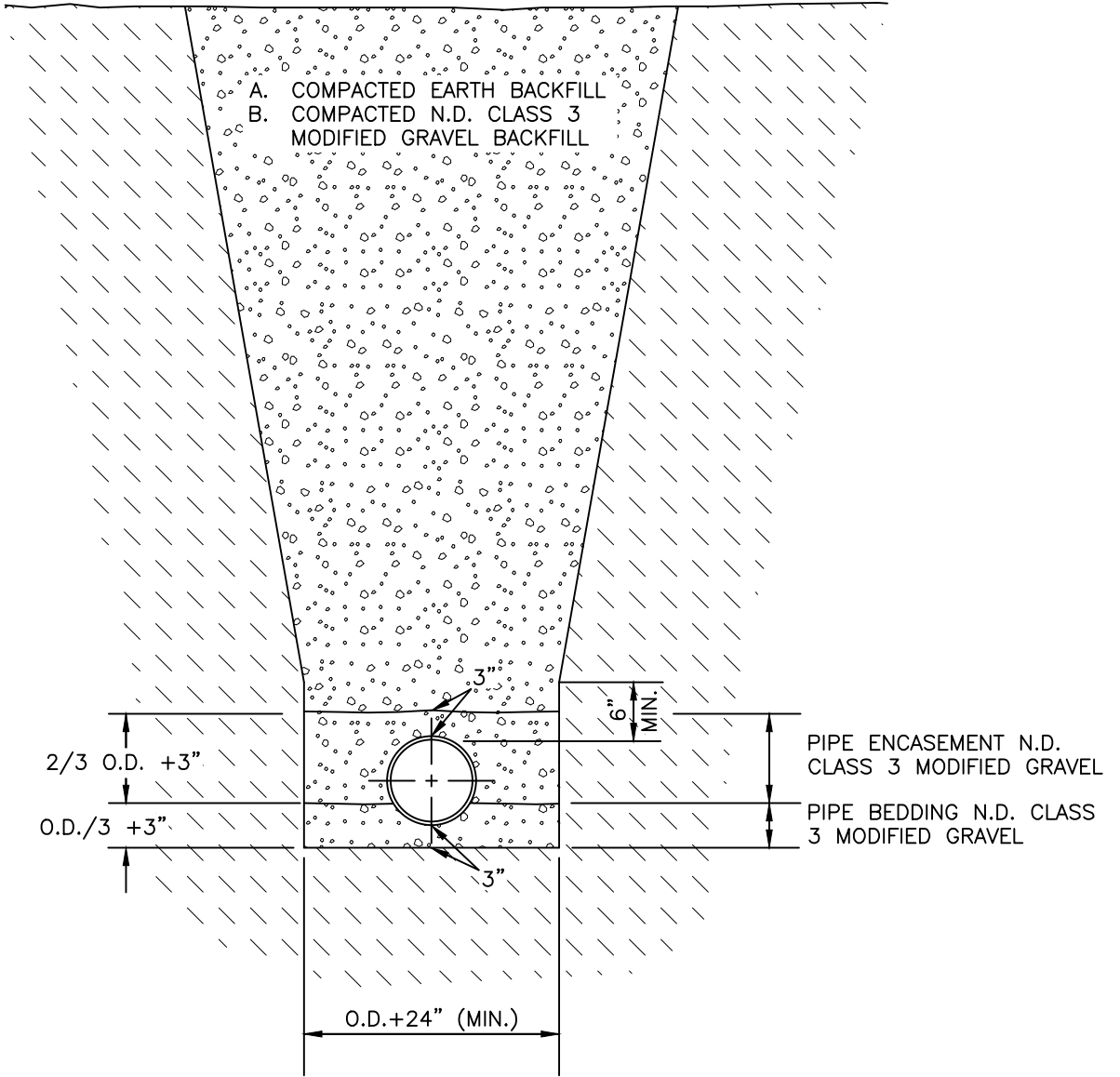

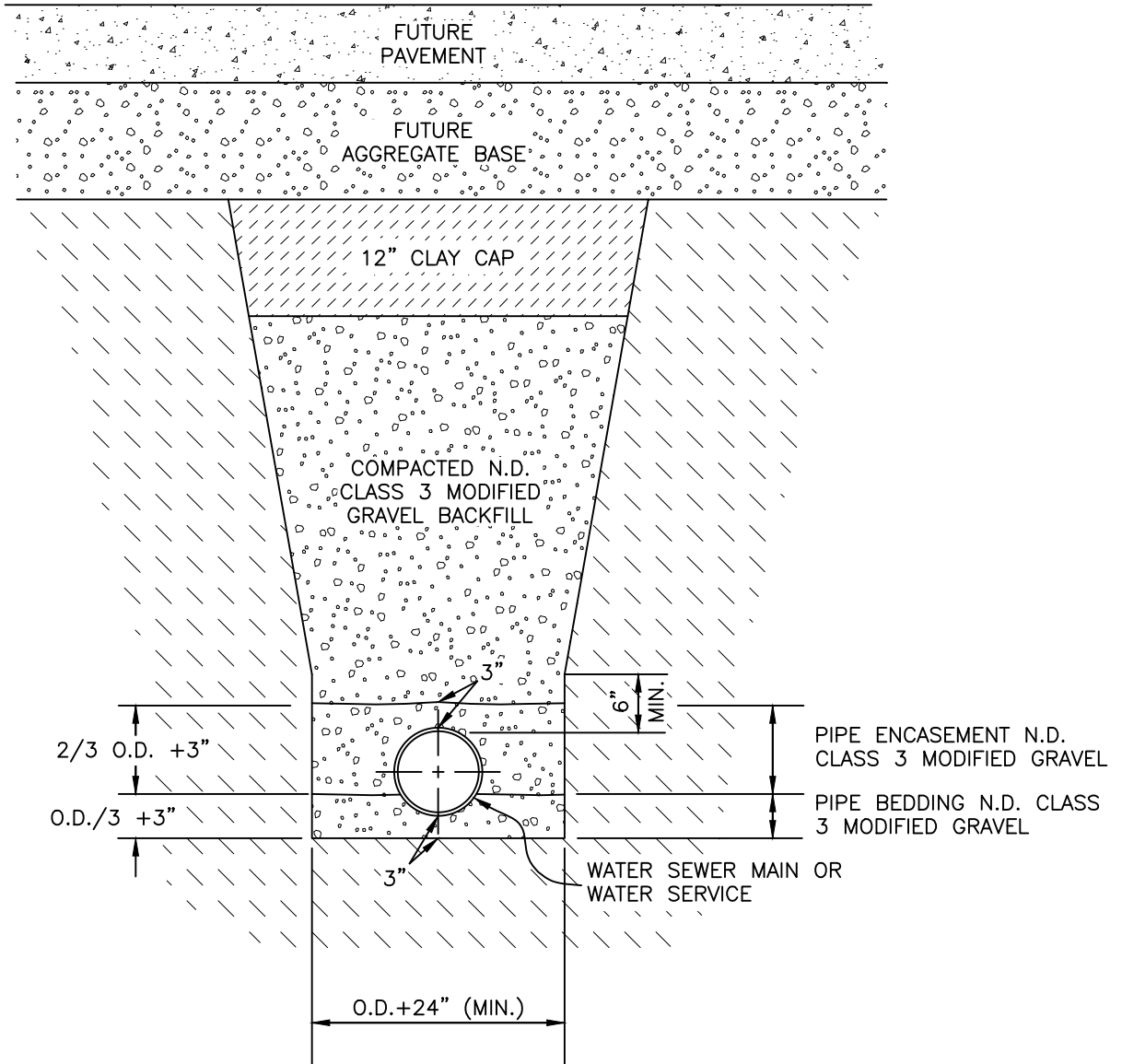

**NOTE:**  
THIS DETAIL APPLIES WHERE WATER  
MAIN IS INSTALLED UNDER FUTURE  
PAVING WITH EDGE DRAIN.

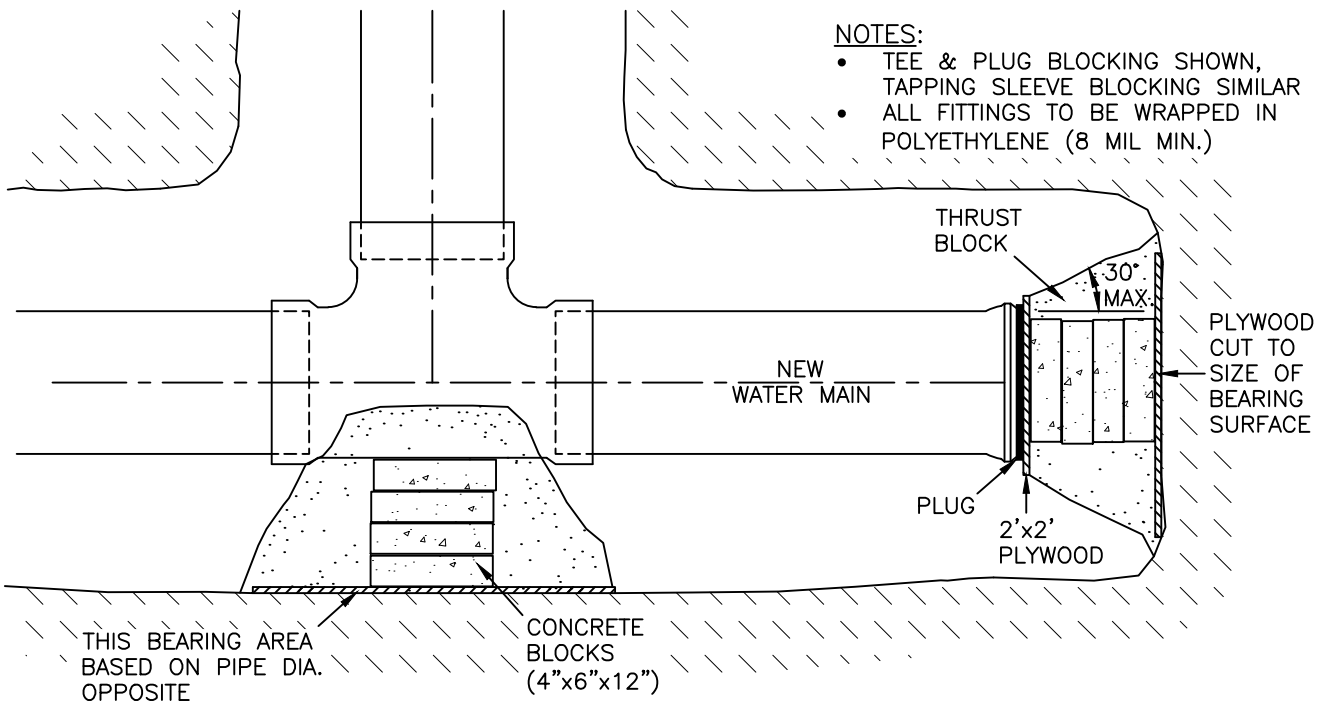

**NOTES:**

- TEE & PLUG BLOCKING SHOWN, TAPPING SLEEVE BLOCKING SIMILAR
- ALL FITTINGS TO BE WRAPPED IN POLYETHYLENE (8 MIL MIN.)

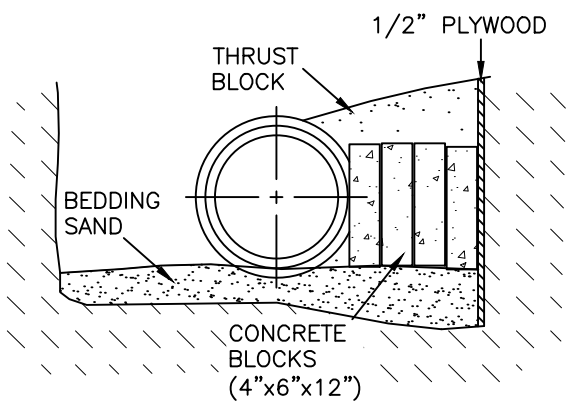

**TABLE OF REQUIRED BEARING AREAS**

PIPE SIZE	BEND ANGLE				TEE
	90°	45°	22-1/2°	11-1/4°	
4"	2' SQ.	2' SQ.	2' SQ.	2' SQ.	2' SQ.
6"	3' SQ.	2' SQ.	2' SQ.	2' SQ.	3' SQ.
8"	5' SQ.	3' SQ.	2' SQ.	2' SQ.	4' SQ.
10"	8' SQ.	4' SQ.	3' SQ.	2' SQ.	6' SQ.
12"	11' SQ.	6' SQ.	3' SQ.	2' SQ.	8' SQ.
16"	20' SQ.	11' SQ.	6' SQ.	4' SQ.	15' SQ.
18"	25' SQ.	14' SQ.	7' SQ.	4' SQ.	18' SQ.

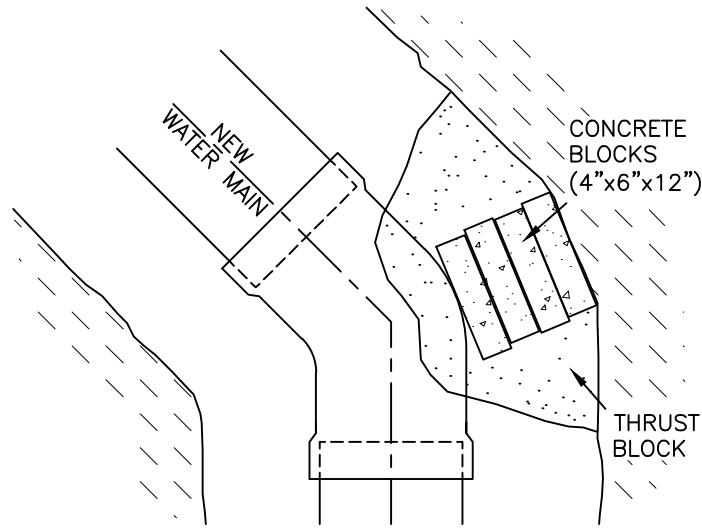

**NOTES:**

- CONCRETE BLOCKING TO BE POURED AGAINST UNDISTURBED EARTH. BELLS AND BOLTS TO BE KEPT FREE OF CONCRETE. CONCRETE IN PLACE TO BE INCLUDED IN PRICE BID FOR WATER MAIN.
- IF APPROVED BY THE ENGINEER, SOLID CONCRETE BLOCKS MAY BE USED FOR BLOCKING ON 8" DIA PIPE AND BELOW. 10" DIA. PIPE AND ABOVE WILL CONFORM TO CONCRETE POURED IN PLACE AREAS SHOWN ABOVE.



SECTION: 1300	DRAWING: 5.3
REVISION: 1999	
<b>WATER MAIN THRUST BLOCKING</b>	
APPROVED:	DATE:

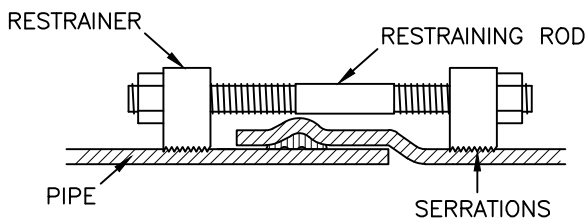

2" TO 12" DIA.

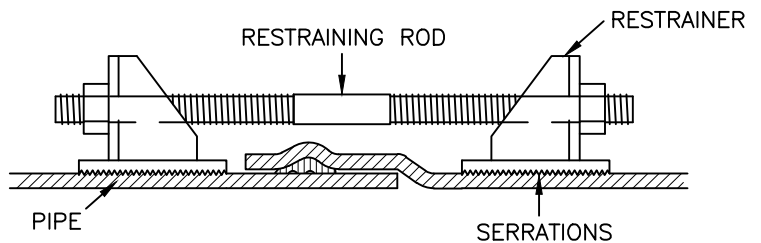

14" TO 36" DIA.

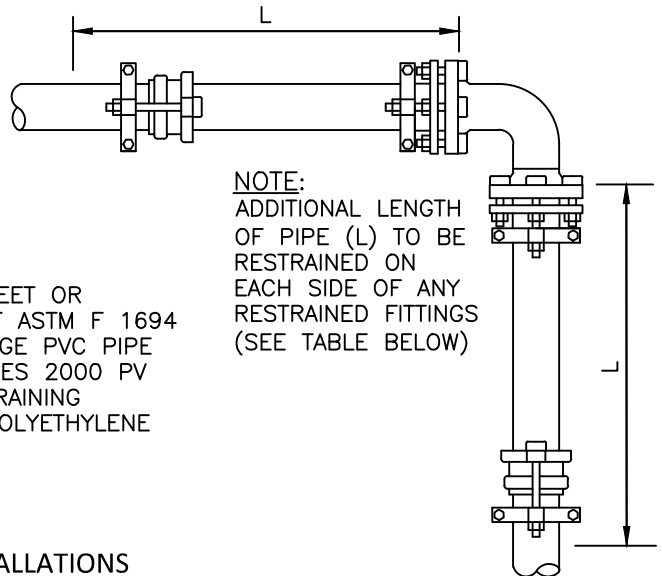
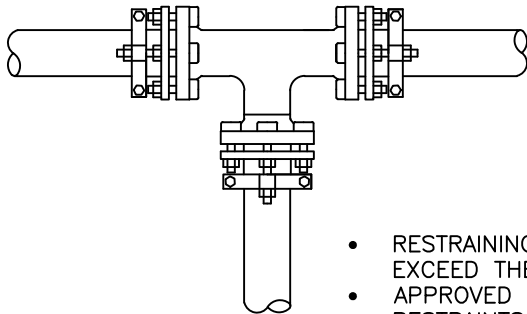
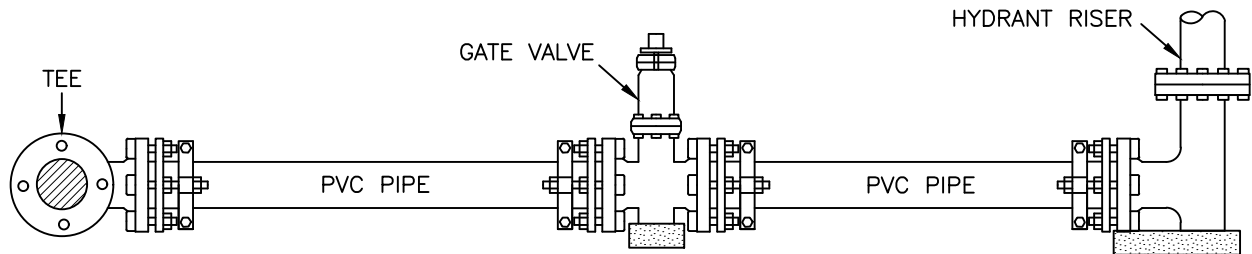

NOTE:  
ADDITIONAL LENGTH  
OF PIPE (L) TO BE  
RESTRAINED ON  
EACH SIDE OF ANY  
RESTRAINED FITTINGS  
(SEE TABLE BELOW)

- RESTRAINING DEVICES SHALL MEET OR EXCEED THE REQUIREMENTS OF ASTM F 1694
- APPROVED TYPES ARE UNIFLANGE PVC PIPE RESTRAINTS & EEBA IRON SERIES 2000 PV
- ALL METAL FITTINGS AND RESTRAINING DEVICES TO BE WRAPPED IN POLYETHYLENE PLASTIC (8 MIL MIN.)

TYPICAL INSTALLATIONS

NOM. PIPE SIZE	90° BEND (L)	45° BEND (L)	22.5° BEND (L)	11.25° BEND (L)	SIZE ON SIZE TEE (L)*	VALVE/ DEAD-END (L)
6"	19'	8'	4'	2'	2'	35'
8"	25'	11'	5'	3'	13'	45'
10"	31'	13'	6'	3'	23'	55'
12"	36'	15'	8'	4'	33'	65'
16"	47'	20'	10'	5'	52'	84'

SIZE	45° VERT. OFFSET* (L)	22.5° VERT. OFFSET* (L)
6"	15'/8"	7'/4"
8"	19'/11"	9'/5"
10"	23'/13"	11'/6"
12"	27'/15"	13'/8"
16"	35'/20"	17'/10"

\* RECOMMENDED RESTRAINED LENGTHS FOR TEES ARE FOR THE BRANCH OUTLET AND ASSUME A MINIMUM 10 FT. SECTION OF PIPE ATTACHED TO EACH SIDE OF THE RUN. RESTRAINT DEVICES ARE ALSO REQUIRED ON BOTH RUN JOINTS OF THE TEE ITSELF.

\* FIRST NUMBER IS THE RECOMMENDED RESTRAINED LENGTH ON EACH SIDE OF THE DOWN BEND, THE SECOND NUMBER IS THE LENGTH FOR EACH SIDE OF THE UP BEND.

RESTRAINED LENGTHS OF PVC PIPE



SECTION: 1300	DRAWING: 5.4
REVISION: 1999	
<b>RESTRAINT DEVICE FOR PVC PIPE BELL JOINTS</b>	
APPROVED:	DATE:

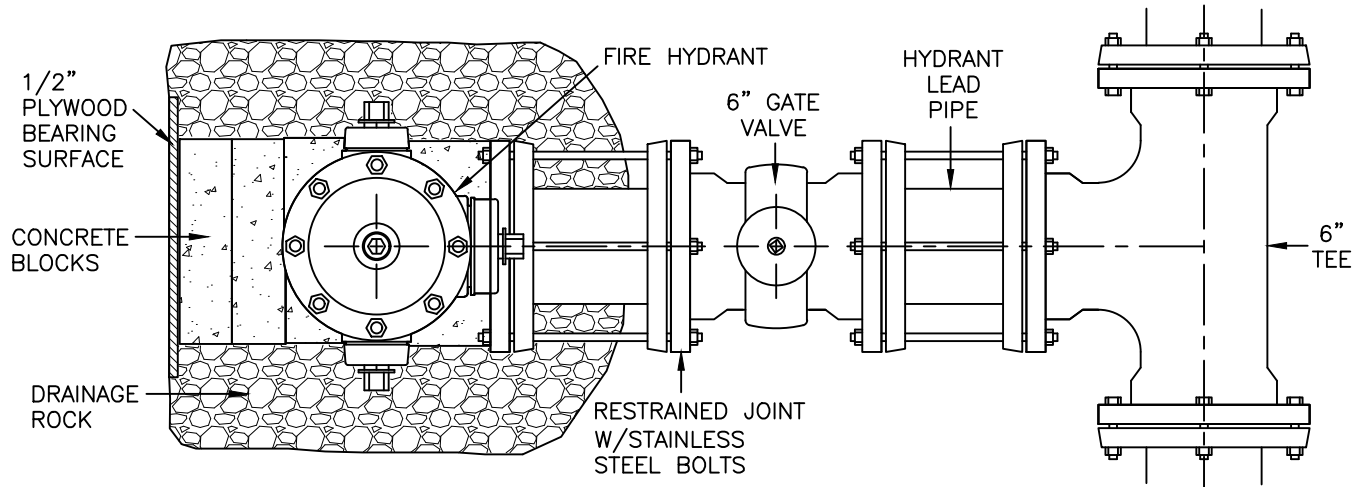

**NOTES:**

- OPERATING & CAP NUTS: CITY OF FARGO STANDARDS
- BOLTS BELOW GROUND SHALL BE STAINLESS STEEL
- LOWER STANDPIPE OF HYDRANTS SHALL BE WRAPPED WITH POLYETHYLENE, NOT TO COVER WEEP HOLES (SEE SECTION 2.2.6)
- REFER TO DETAILS 1300 5.13 & 1300 5.14 FOR TRACER WIRE LAYOUT

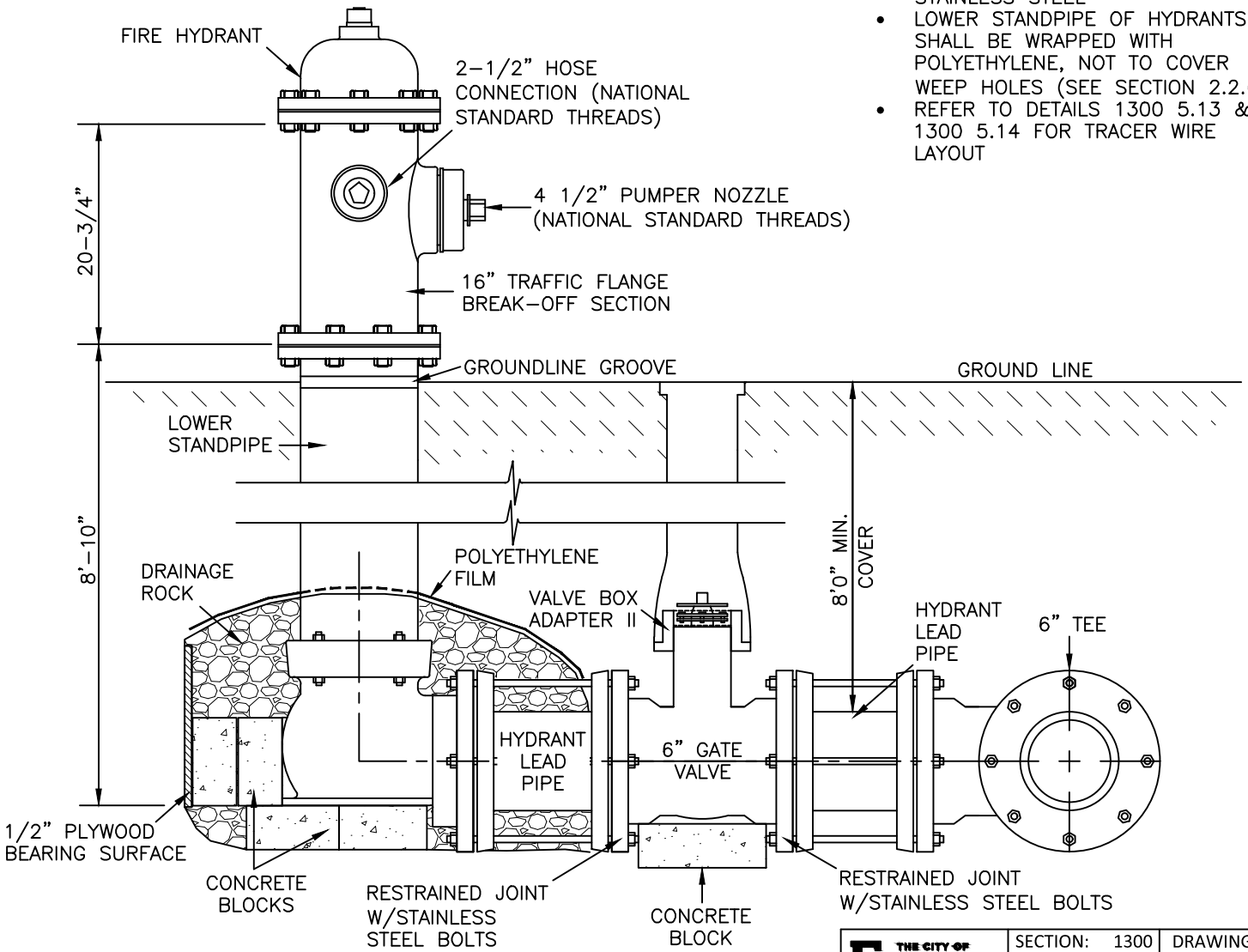

SECTION: 1300	DRAWING: 5.5
REVISION: 2019	
<b>RESTRAINED MECHANICAL JOINT</b>	
APPROVED:	DATE:

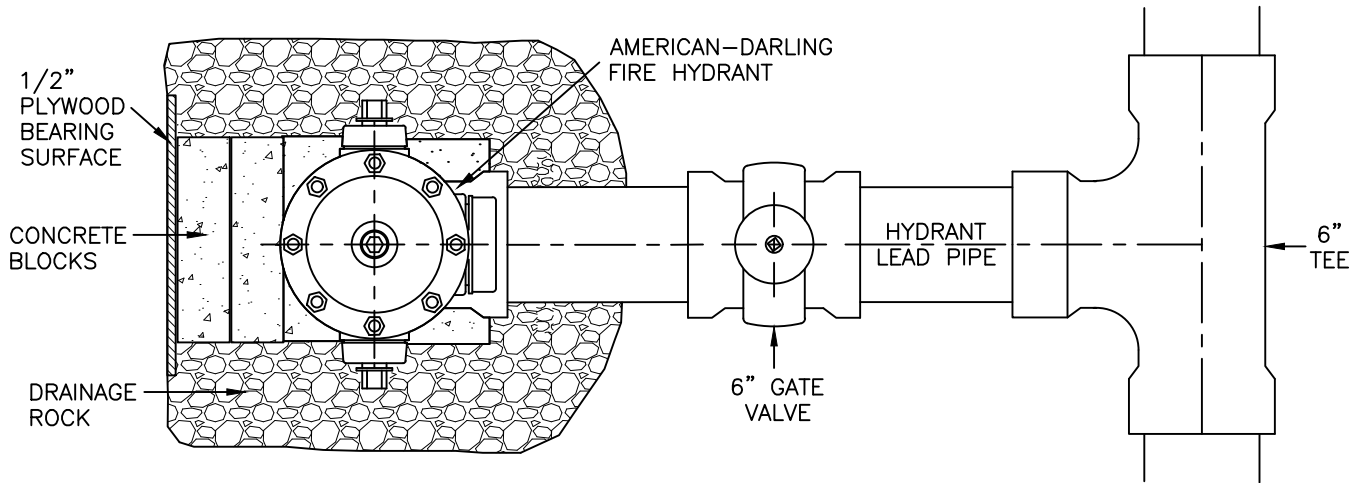

**NOTES:**

- OPERATING & CAP NUTS: CITY OF FARGO STANDARDS
- BOLTS BELOW GROUND SHALL BE STAINLESS STEEL
- LOWER STANDPIPE OF ALL HYDRANTS SHALL BE WRAPPED WITH POLYETHYLENE FILM, NOT TO COVER WEEP HOLES
- REFER TO DETAILS 1300 5.13 & 1300 5.14 FOR TRACER WIRE LAYOUT

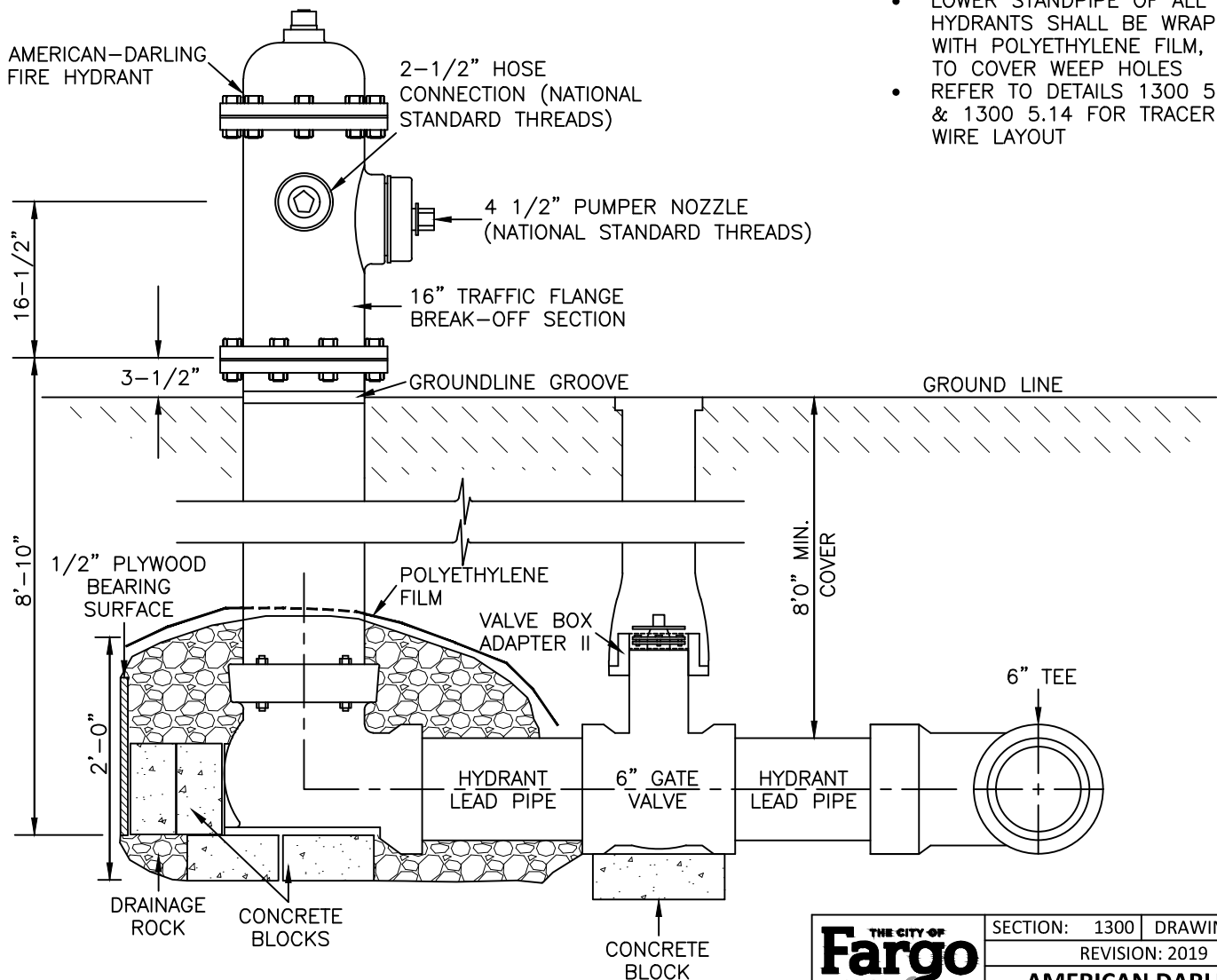

SECTION: 1300	DRAWING: 5.6
REVISION: 2019	
<b>AMERICAN DARLING HYDRANT CONNECTIONS</b>	
APPROVED:	DATE:

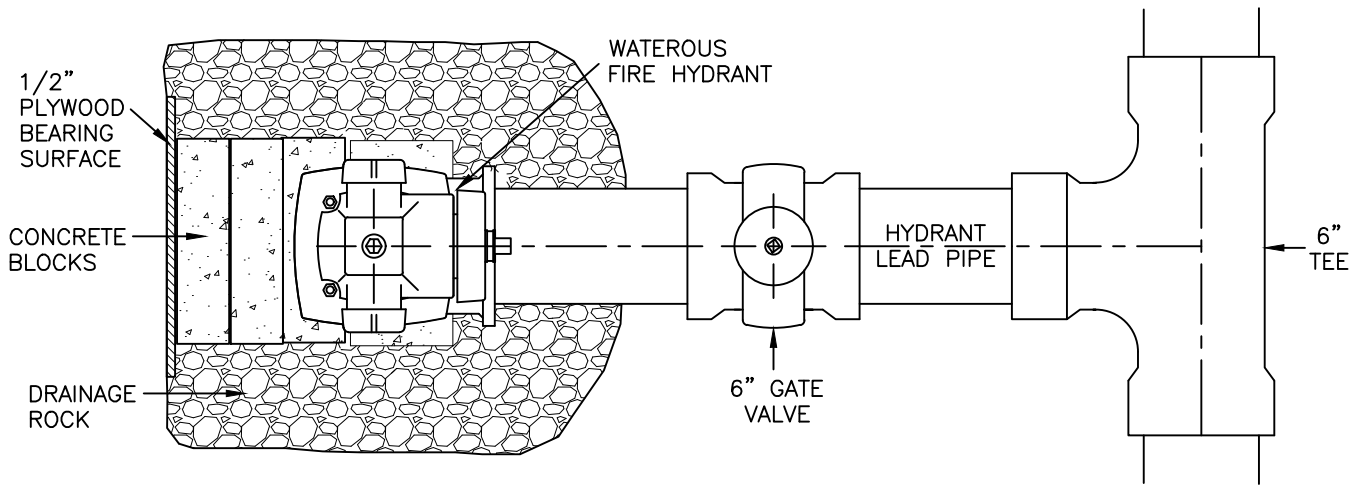

**NOTES:**

- OPERATING & CAP NUTS: CITY OF FARGO STANDARDS
- BOLTS BELOW GROUND SHALL BE STAINLESS STEEL
- LOWER STANDPIPE OF ALL HYDRANTS SHALL BE WRAPPED WITH POLYETHYLENE FILM, NOT TO COVER WEEP HOLES
- REFER TO DETAILS 1300 5.13 & 1300 5.14 FOR TRACER WIRE LAYOUT

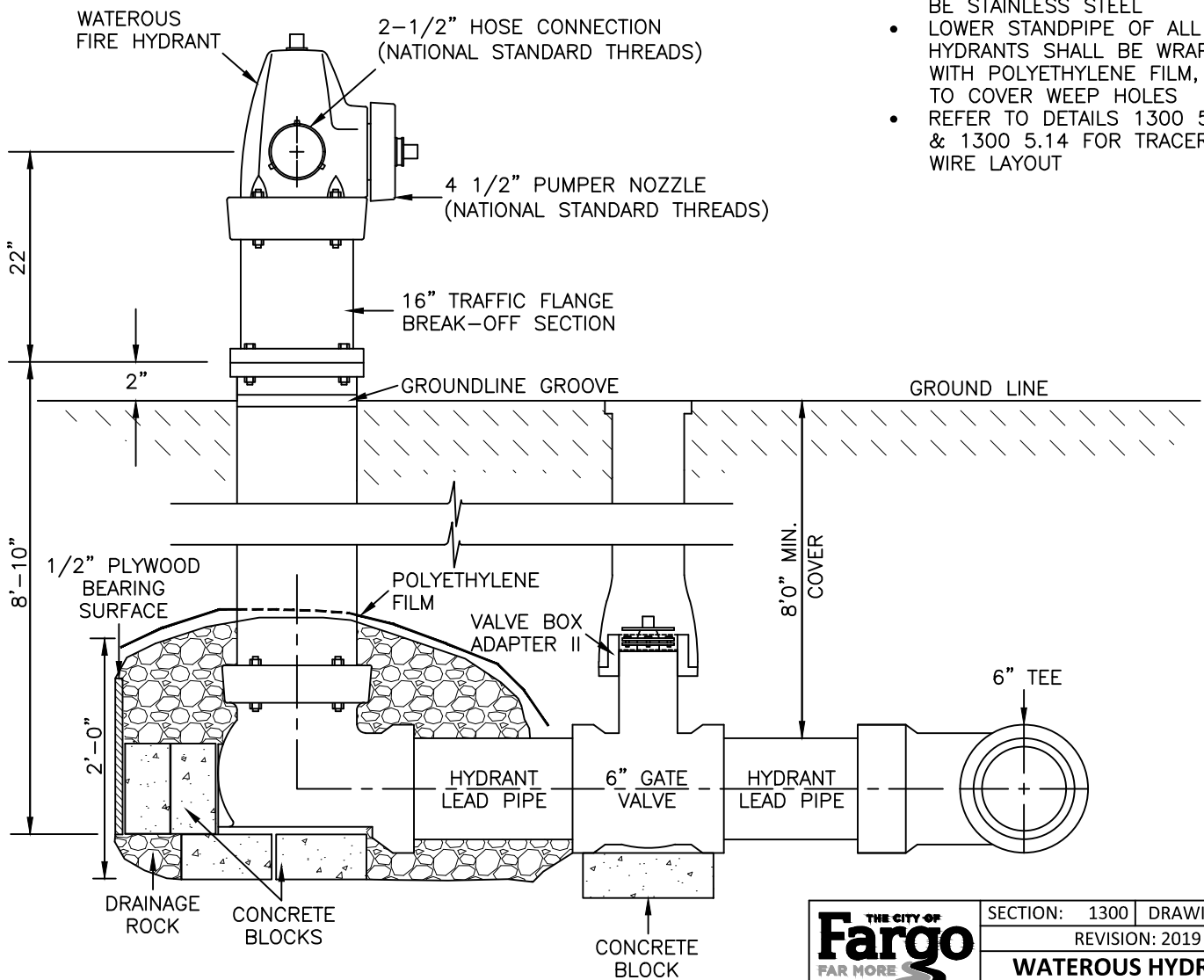

SECTION: 1300	DRAWING: 5.7
REVISION: 2019	
<b>WATEROUS HYDRANT CONNECTIONS</b>	
APPROVED:	DATE:

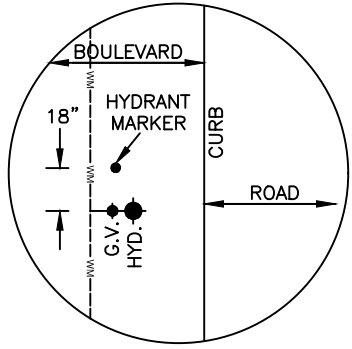

PLAN VIEW

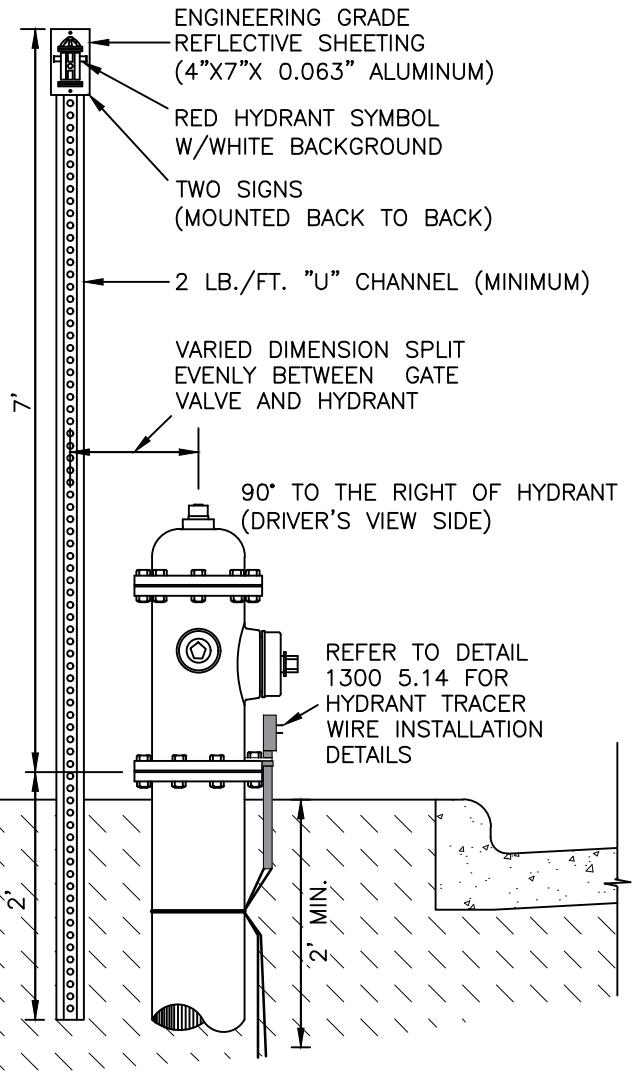

WATERMAIN IN BOULEVARD

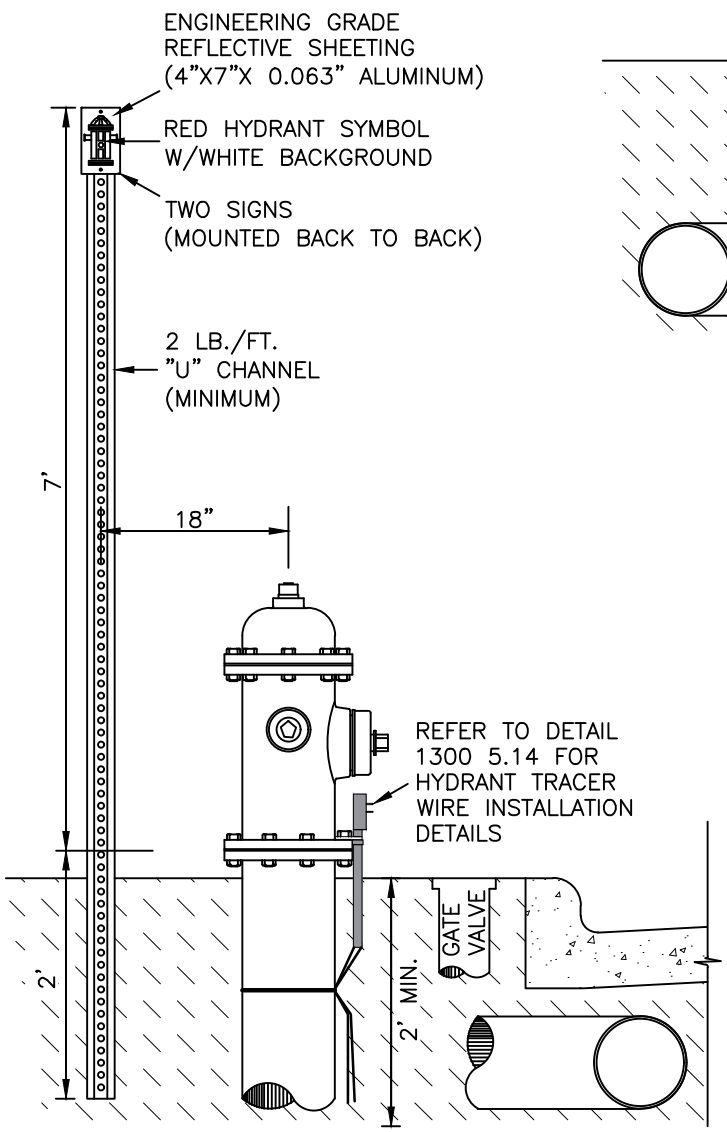

WATERMAIN UNDER ROADWAY

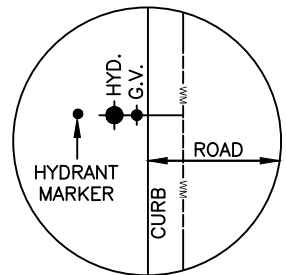

PLAN VIEW

  
 THE CITY OF  
**Fargo**  
 FAR MORE  
 ENGINEERING  
 DEPARTMENT

SECTION: 1300	DRAWING: 5.8
REVISION: 2019	
<b>HYDRANT MARKER DETAIL</b>	
APPROVED:	DATE:



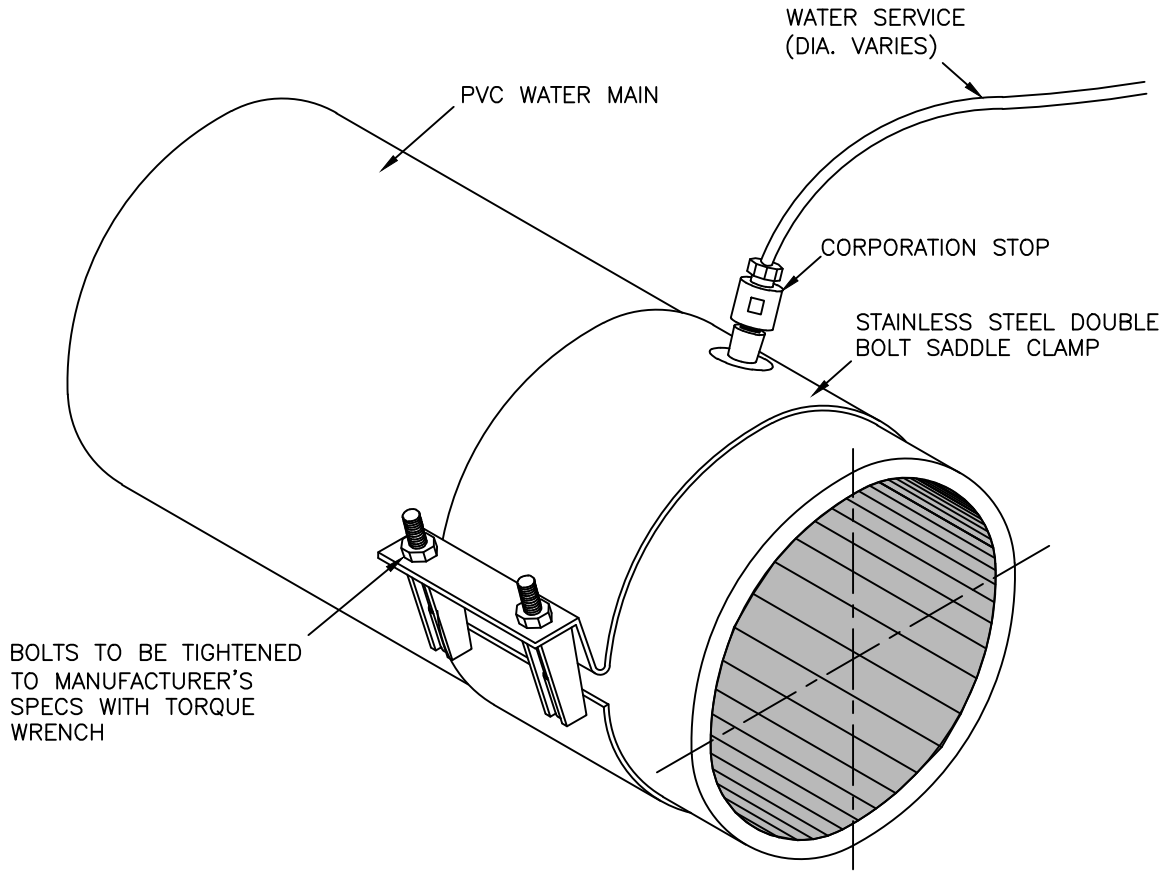

**NOTES:**

- THE CONTRACTOR WILL BE REQUIRED TO USE ALL STAINLESS STEEL SADDLE SERVICES. DIRECT TAPS WILL NOT BE PERMITTED.
- REFER TO DETAILS 1300 5.13 & 1300 5.14 FOR TRACER WIRE LAYOUT.

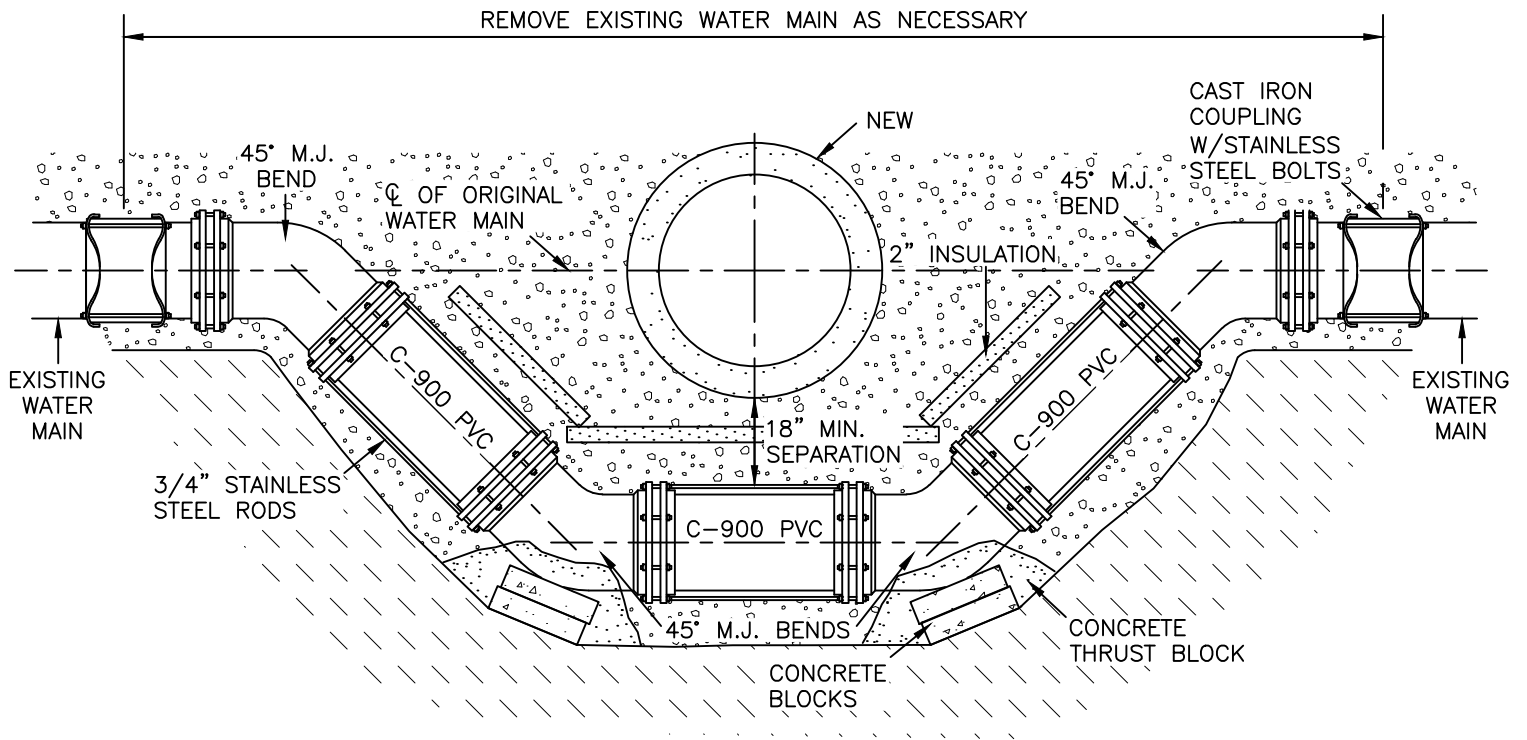

**NOTES:**

- ALL FITTINGS TO BE WRAPPED IN POLYETHYLENE PLASTIC (8 MIL MIN.)
- BELLS AND BOLTS TO BE KEPT FREE OF CONCRETE.
- ALL JOINTS TO HAVE RESTRAINING GLANDS WITH  $\frac{3}{4}$ " STAINLESS RODS.



SECTION: 1300	DRAWING: 5.10
REVISION: 2019	
<b>WATER MAIN RELOCATION DETAIL</b>	
APPROVED:	DATE:

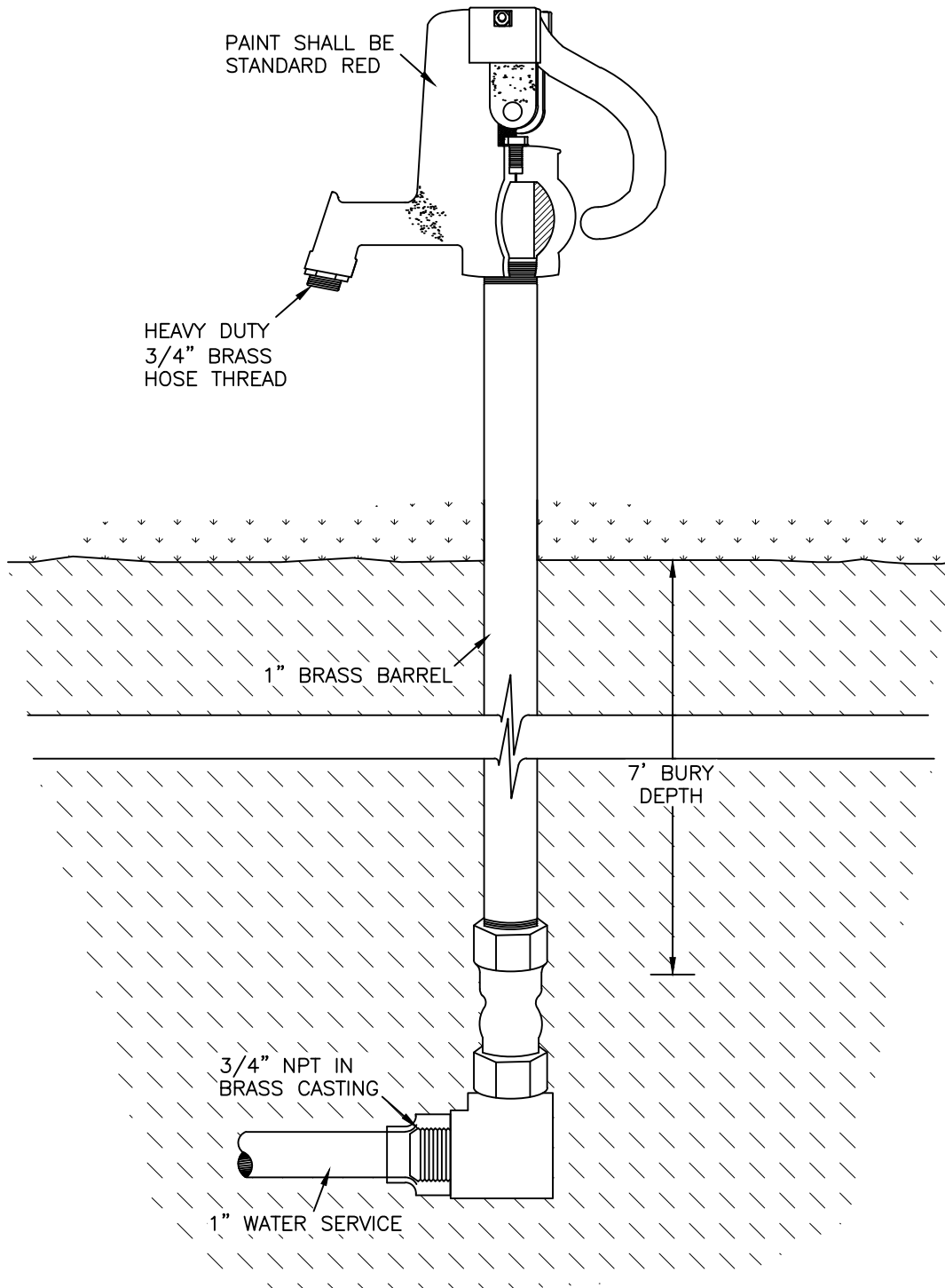

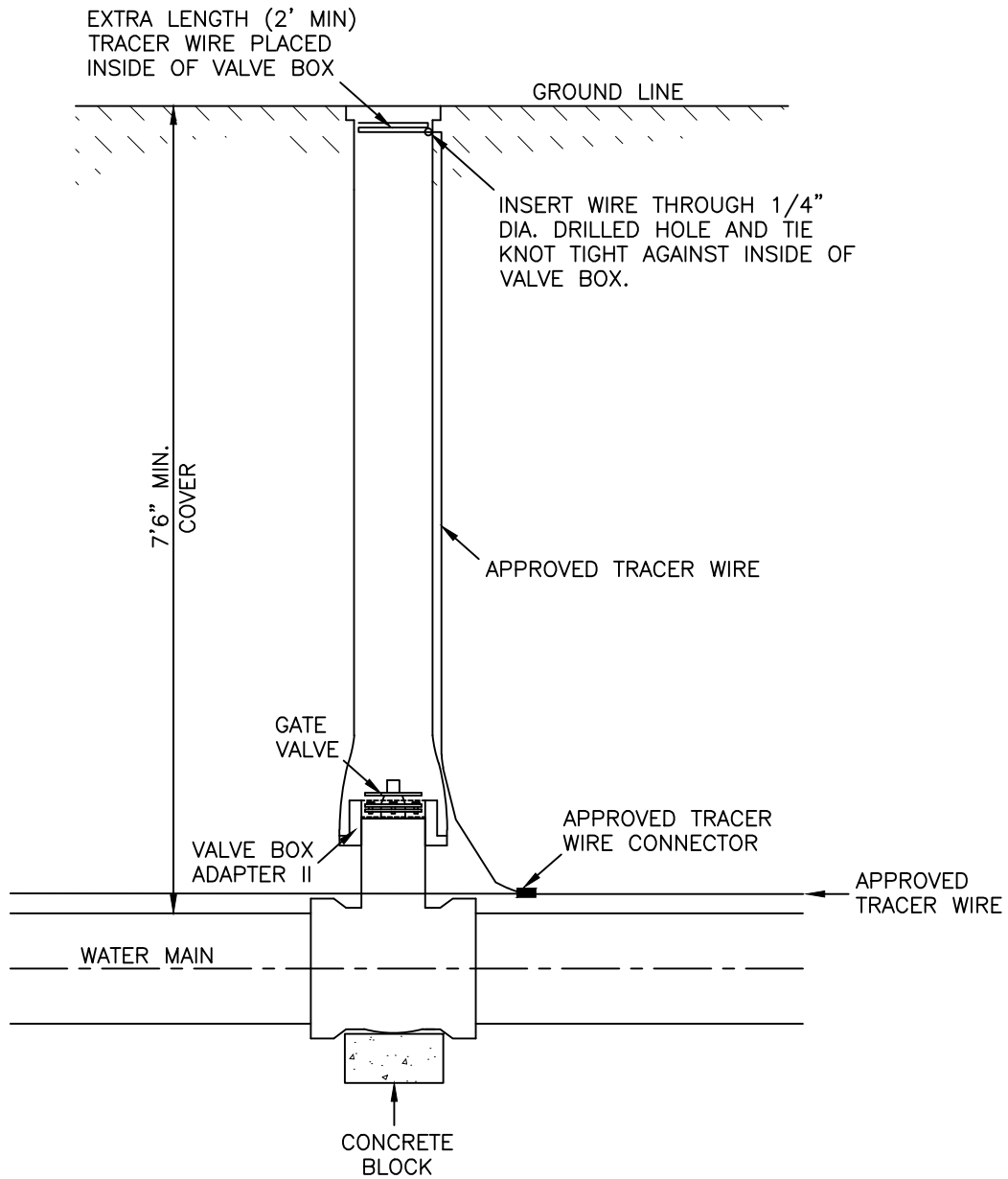

**NOTE:**  
 TRACER WIRE WILL NOT NORMALLY BE INSTALLED VERTICALLY UP VALVE BOXES AS SHOWN. THIS DETAIL APPLIES ONLY WHERE SPECIFICALLY CALLED FOR ON THE PLANS OR AS DIRECTED BY THE ENGINEER.



SECTION: 1300	DRAWING: 5.12
REVISION: 2019	
<b>VALVE TRACER WIRE DETAIL</b>	
APPROVED:	DATE:

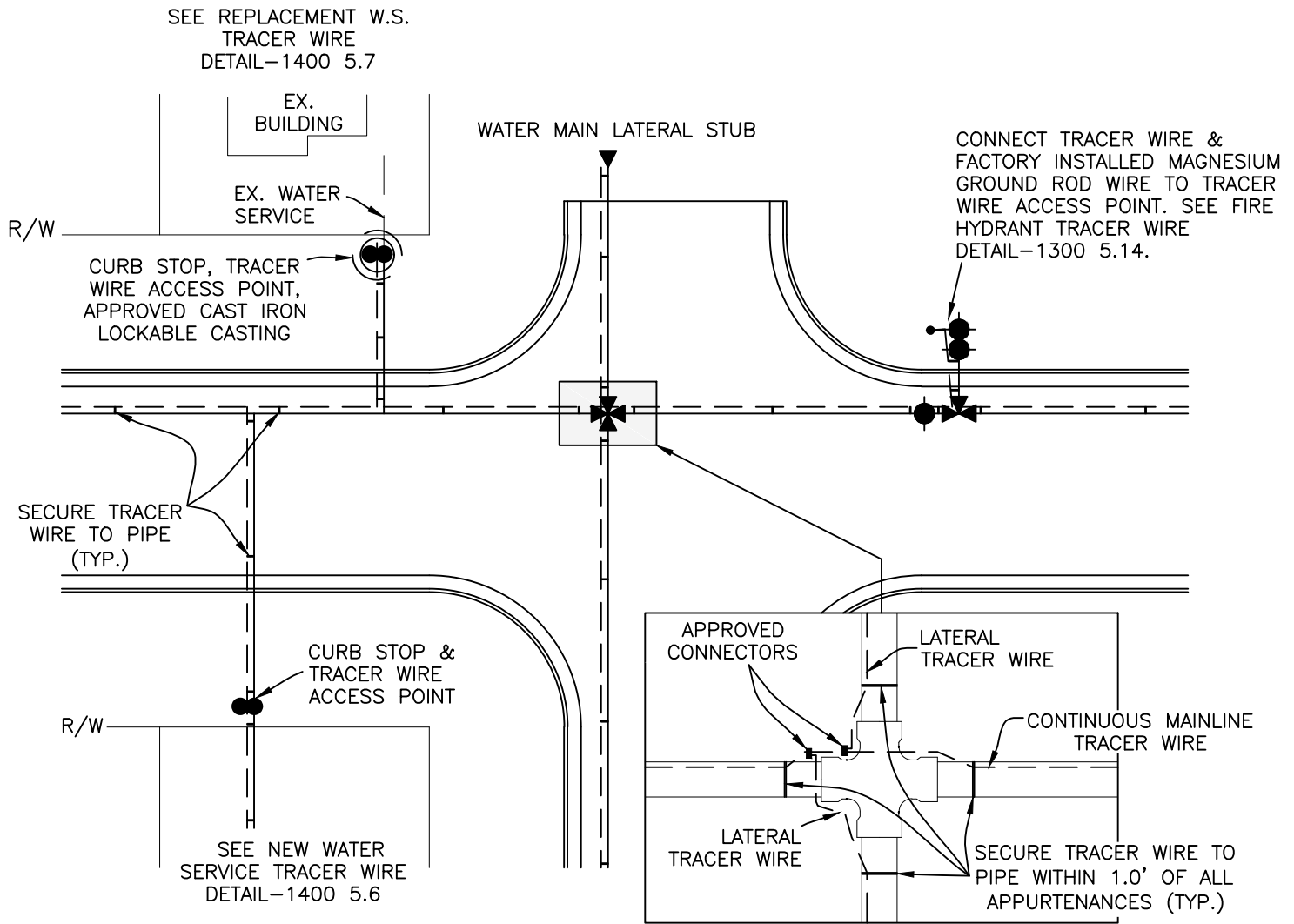

**NOTES:**

1. TRACER WIRE SHOWN AWAY FROM PIPE FOR CLARITY.
2. TRACER WIRE SHALL BE INSTALLED BELOW THE SPRING LINE OF WATER MAIN PIPES AND AROUND THE SIDE OF WATER MAIN FITTINGS.
3. MAINLINE TRACER WIRE SHALL BE SECURED TO THE MAINLINE PIPE WITH TAPE OR PLASTIC TIES AT EVERY PIPE BELL OR AT 20 FOOT INTERVALS, WHICHEVER IS LESS. IN ADDITION, MAINLINE TRACER WIRE SHALL BE SECURED WITHIN 1 FOOT OF ALL UNDERGROUND UTILITY APPURTENANCES.
4. LATERAL TRACER WIRE FOR WATER SERVICES SHALL BE SECURED TO THE WATER SERVICE PIPE WITH TAPE OR PLASTIC TIES AT A MAXIMUM OF 10 FOOT INTERVALS. IN ADDITION, LATERAL TRACER WIRE SHALL BE SECURED WITHIN 1 FOOT OF ALL UNDERGROUND UTILITY APPURTENANCES.
5. MAINLINE TRACER WIRE SHALL BE INSTALLED AS A SINGLE CONTINUOUS WIRE. SPLICES SHALL NOT OCCUR MORE FREQUENTLY THAN ONE PER 500 FEET.
6. LATERAL TRACER WIRES SHALL BE A SINGLE WIRE, CONNECTED TO THE MAINLINE TRACER WIRE USING AN APPROVED CONNECTOR, INSTALLED WITHOUT CUTTING/SPLICING THE MAINLINE TRACER WIRE.
7. MAGNESIUM GROUND RODS SHALL BE INSTALLED AT ALL HYDRANTS AND SHALL BE COMPLETELY DRIVEN INTO VIRGIN SOIL BELOW PIPE BEDDING.
8. ALL NEW CONSTRUCTION WATER SERVICES SHALL INCLUDE AN APPROVED TRACER WIRE ACCESS POINT.
9. WHEN CURB STOP BOX AND/OR TRACER WIRE ACCESS POINT ARE LOCATED IN A HARD SURFACED AREA THEY SHALL BE PLACED INSIDE AN APPROVED CAST IRON LOCKABLE CASTING.



SECTION: 1300	DRAWING: 5.13
REVISION: 2019	
<b>MAINLINE TRACER WIRE DETAIL</b>	
APPROVED:	DATE:

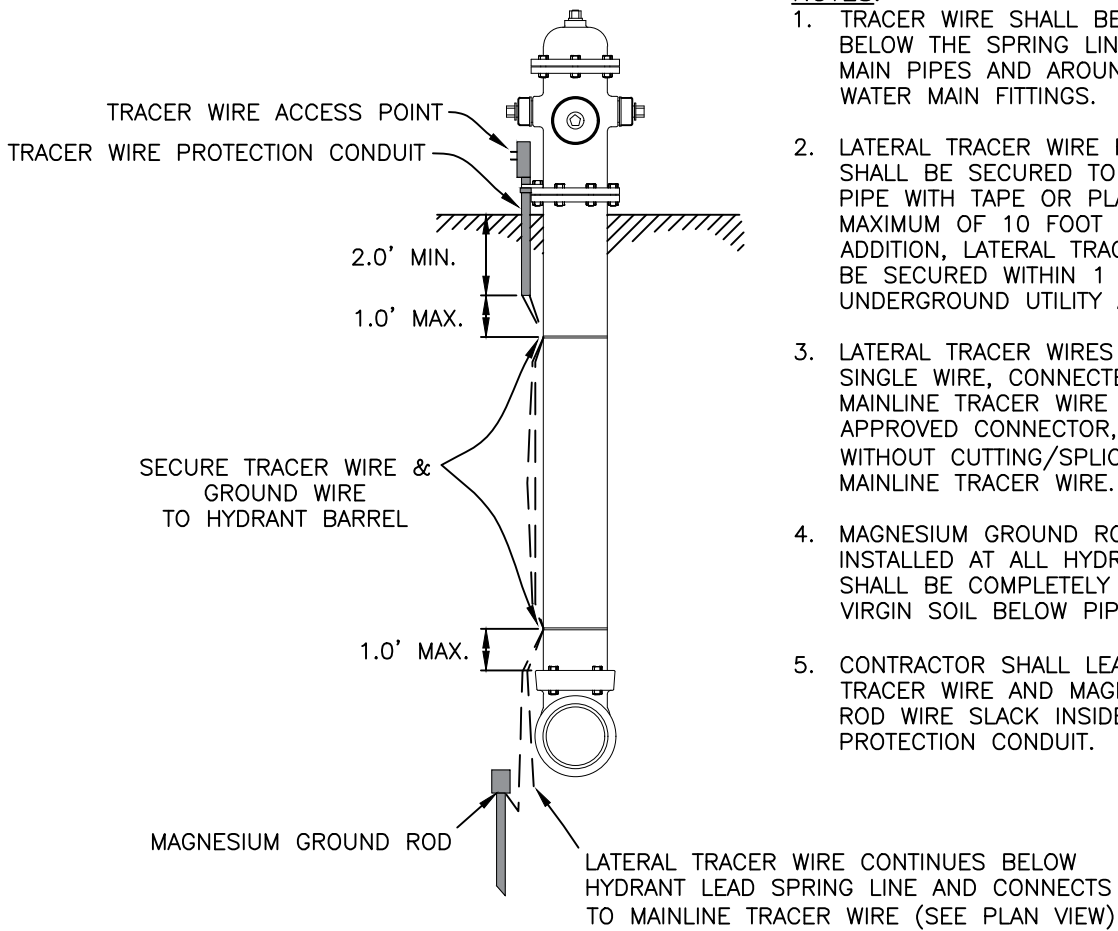

**HYDRANT - PROFILE VIEW**  
NOT TO SCALE

**NOTES:**

1. TRACER WIRE SHALL BE INSTALLED BELOW THE SPRING LINE OF WATER MAIN PIPES AND AROUND THE SIDE OF WATER MAIN FITTINGS.
2. LATERAL TRACER WIRE FOR HYDRANTS SHALL BE SECURED TO THE WATER PIPE WITH TAPE OR PLASTIC TIES AT A MAXIMUM OF 10 FOOT INTERVALS. IN ADDITION, LATERAL TRACER WIRE SHALL BE SECURED WITHIN 1 FOOT OF ALL UNDERGROUND UTILITY APPURTENANCES.
3. LATERAL TRACER WIRES SHALL BE A SINGLE WIRE, CONNECTED TO THE MAINLINE TRACER WIRE USING AN APPROVED CONNECTOR, INSTALLED WITHOUT CUTTING/SPLICING THE MAINLINE TRACER WIRE.
4. MAGNESIUM GROUND RODS SHALL BE INSTALLED AT ALL HYDRANTS AND SHALL BE COMPLETELY DRIVEN INTO VIRGIN SOIL BELOW PIPE BEDDING.
5. CONTRACTOR SHALL LEAVE 24" OF TRACER WIRE AND MAGNESIUM GROUND ROD WIRE SLACK INSIDE TRACER WIRE PROTECTION CONDUIT.

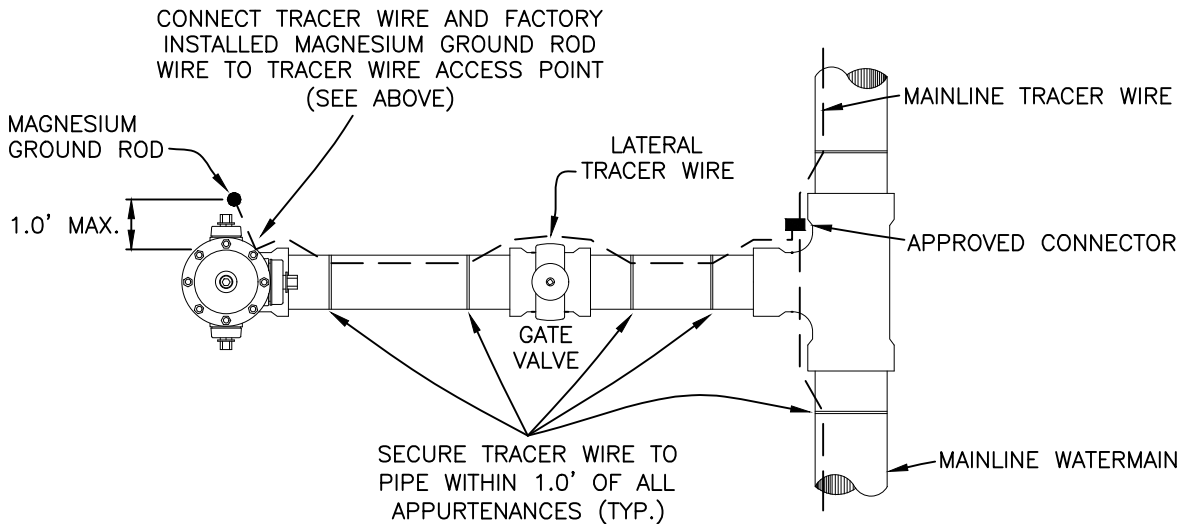

**HYDRANT - PLAN VIEW**  
NOT TO SCALE



SECTION: 1300	DRAWING: 5.14
REVISION: 2019	
<b>FIRE HYDRANT TRACER WIRE DETAIL</b>	
APPROVED:	DATE:

**CITY OF FARGO SPECIFICATIONS  
SEWER AND WATER SERVICE CONNECTIONS**

**PART 1  
DESCRIPTION OF WORK**

The work to be done under this section of the Specifications and the accompanying plans consists of the furnishing of all labor, material, accessories and equipment necessary to construct sewer and water service connections. The work includes excavation, furnishing and laying sewer and water pipe according to these Specifications; protecting existing utilities and public and private property; testing all new water connections; backfilling trenches and other work as may be necessary to insure that the work be completed in accordance with these Specifications and the plans accompanying them.

**PART 2**  
**MATERIAL**

2.1. SEWER SERVICE CONNECTIONS

2.1.1. *PIPE*

The material shall conform to “Standard Specifications for Rigid Polyvinyl Chloride Compounds”, ASTM D-1784, Class 12454-B or 12454-C or 12364-C. The pipe shall be produced using a continuous extrusion process employing a prime grade of white unplasticized polyvinyl chloride.

All PVC pipe and specials shall be 6 inch diameter complying with the requirements of ASTM D-3034 PVC pipe, SDR 26 or Schedule 40 PVC. 4” PVC, when approved by the Engineer, shall be Schedule 40 PVC.

2.1.2. *JOINTING*

The joint system shall be an integral bell gasketed joint that forms a watertight seal in accordance with ASTM Specification D3212 and F477. If Schedule 40 is used, the joints shall be solvent weld, watertight and installed as per the manufacture recommendation.

2.1.3. *WYES AND FITTINGS*

Wyes and fittings shall be as manufactured by GPK Products, Inc. or approved equal. Gasketed wyes and fittings shall be used unless otherwise approved by the Engineer.

- A. New construction: In-line wyes will be required on all new construction and shall be SDR 26.
- B. When new taps are necessary on existing mains, PVC saddle wyes with a rubber gasket shall be used. The saddle wyes shall be installed as per the manufacturer’s recommendation and attached with two stainless steel straps. Inserta- tees shall be installed by coring the existing sewer main, patching any openings and installing the Inserta-Tee. Inserta-Tees will only be allowed when approved by the Engineer.



- C. When connecting to an existing clay main: Using care, the Contractor shall remove the entire wye branch down to the main and install a PVC saddle wye.

#### *2.1.4. CONNECTIONS TO EXISTING SERVICE LINES*

When connecting PVC to PVC, a gasketed, heavy wall PVC coupler shall be used. For all other connections between new and existing service lines, a flexible elastomeric PVC wrapped in a stainless steel shear ring shall be used. Approved products include Fernco Strong Back RC Series repair couplings, GPK couplings with stainless steel sheer rings, or approved equal.

#### *2.1.5. MARKERS*

For new construction projects, a marker shall be placed at the end of the sewer service. Markers shall be a 2" by 2" by 8-foot wood with the top 2 feet painted green. Marker shall extend from the cap at the end of the sewer service to 6' above the ground.

### 2.2. WATER SERVICE CONNECTIONS

All products (treatment chemicals and material) that may come into contact with water intended for use in a public water system shall meet American National Standards Institute (ANSI)/National Sanitation Foundation (NSF) International Standards 60 & 61, as appropriate. A product will be considered a meeting these standards if so certified by NSF, The Underwriters Laboratories, or other organizations accredited by ANSI to test and certify such products.

#### *2.2.1. PIPE*

All underground water service pipe 2 inches in diameter or smaller shall be type "K" copper or Cross-linked Polyethylene (PEX) pipe. Newly installed water service pipe shall be minimum of 1 inch in diameter. All water service pipe larger than 2 inches in diameter shall be manufactured in accordance with the latest revision of AWWA Standard C900 and be DR18.

PEX pipe shall meet the following criteria:

- Manufactured using high-pressure peroxide method of cross-linking.
- Manufactured to SDR9 copper tube sizes (CTS) according to ASTM F876, AWWA C904, and CSA B137.5.

- Certified to AWWA C904 Cross-linked Polyethylene (PEX) Pressure Pipe for Water Service
- Certified to CSA B137.5 Cross-linked Polyethylene (PEX) tubing for Pressure Applications
- Certified to NSF/ANSI Standards 14 and 61 (NSF-pw-g) for potable water applications
- Certified to PPI TR-3 Category 3306 for long-term hydrostatic strength, chlorine and UV resistance.
- Co-extruded UV Shield made from UV-resistant high-density polyethylene, color Blue.
- Minimum recommended UV exposure time of one (1) year when tested in accordance with ASTM F2657.
- Pressure-rated for continuous use at 200 psi @ 73.4 °F based on a 0.63 design factor.
- Minimum markings: PEXa 3306, CSA B137.5, ASTM F876, F2023 and F2080, NSF-pw.
- Approved by manufacturer for use with manual plastic pipe squeeze-off tools for temporary stoppage of flow.

#### 2.2.2. JOINTS

Compression fittings shall be used for all water services 2 inches in diameter or smaller (copper and PEX). Compression fittings shall be Mueller 110 Compression, Ford Quick Joint, A.Y. McDonald McQuik, or approved equal.

Underground fittings and insert-stiffeners used with PEX pipe must comply with the material and performance requirements of ANSI/AWWA C800 and must be recommended for use by the fitting manufacturer for CTS SDR9 PEX pipe per the ANSI/AWWA C904 standard. Insert-stiffeners shall be stainless steel.

#### 2.2.3. CORPORATION STOPS

Corporation stops shall be ball style such as Mueller B-250008N, Ford FB1000, McDonald 74701BQ, or approved equal.

#### 2.2.4. CURB STOPS

Curb stops shall be ball style such as Mueller, Ford, McDonald, or approved equal ball valve with a copper tube size inlet and outlet. The arrow shall be placed in the direction of water flow. They shall be of the Minneapolis pattern type.

2.2.5. *CURB BOXES*

Curb boxes shall be A. Y. McDonald 5622C or approved equal. They shall be of the extension type with a Minneapolis pattern base and have an 8-foot bury length. A 6-inch extension with a threaded coupler shall also be supplied and installed. Boxes shall be made in the USA and furnished with a cast iron (not brass) plug threading into a cast iron cover (no brass insert).

2.2.6. *MARKERS*

For new construction projects, a 2" by 2" by 3-foot long wood marker shall be placed at the tail of the water service line and a 2" by 2" by 8-foot long wood marker with the top 2 feet painted blue or a metal "T" post painted blue shall be placed near the curb stop box. The tracer wire access point shall be securely taped to the marker near the curb stop box.

2.2.7. *TRACER WIRE AND TRACER WIRE ACCESSORIES*

Tracer wire and tracer wire accessories shall meet the requirements of Section 1300 2.11 and Section 1300 3.12. Tracer wire access points for water services shall be "SnakePit Lite Duty Access Point" with a blue, single-terminal cast iron lid or approved equal.

2.2.8. *SERVICE CONNECTIONS*

All service connections to PVC pipe shall be stainless steel, double bolt (minimum) service saddles. Service saddles shall have stainless steel washers between the nut and the plastic washer to equalize tightening stress. Rubber tapered gaskets shall be required to resist circumferential and longitudinal forces along with O-ring or flat gaskets for hydraulic seal. Saddle bolts shall be tightened to the manufacturers recommended tightness and verified with a torque wrench. Bolt tightness shall be rechecked with a torque wrench after the pipe tap is complete.

Service saddles shall be Romac style 306, Ford style FS 300, Powerseal 3412AS, Cascade CSC2, or approved equal.

**PART 3**  
**CONSTRUCTION**

3.1. EXCAVATION, TRENCHING, AND BACKFILLING

Excavation, trenching and backfilling shall be done in accordance with Section #1000, with the following special considerations:

A. BACKFILLING- EARTH

Backfilling shall be commenced as soon as the connection has been measured and accepted by the Engineer. Special attention is called to the backfilling around the water pipe at the corporation. The earth shall be tamped as solidly as possible to prevent settlement that may cause a strain at this joint. Backfilling shall be done in layers of 6 inches or less and thoroughly compacted. No trench shall be left open for more than 48 hours.

B. BACKFILLING- GRAVEL

Backfilling shall be commenced as soon as the connection has been measured and accepted by the Engineer. Under this item, N. D. Class 3 (modified to 3-15% passing the number 200 sieve) gravel shall be used. The backfilled trench shall be compacted to 95% Standard Proctor Density

3.2. LOCATION AND GRADE

The Engineer will stake the locations of service connections to the main. Connections to the main sewer shall be made only to existing wyes. Wyes may be sprung in only with permission from the Engineer. No excavation for any connection shall be made until the location of the connection is determined and the line and grade established. The sewer grade shall not be less than 1/8 inch per foot and pipe shall be laid straight and to grade.

3.3. SEWER SERVICES

The bottom of the trench shall be excavated so that at least 1/3 of the circumference of the pipe shall have a firm bearing. Bell holes shall be dug to prevent damage to the pipe and prevent the pipe from resting on the bells. Vertical or nearly vertical risers from deep sewer mains shall be protected by tamping the earth around them in a manner that protects them from breaking. The ends of the pipe

shall be plugged during construction to prevent earth or other material from entering the pipe and closed with a plug or disc made from the same material as the pipe and properly secured to prevent its displacement. For new construction projects, the sanitary sewer service shall be installed and backfilled as the mainline sewer is installed and backfilled and all sewer services shall be low pressure air tested with the sewer main.

When encountered on the project, the Contractor shall determine whether a sewer service is active or inactive by televising, dye testing, or other methods approved by the Engineer.

#### 3.3.1. Bored Sewer Services

When sewer services are bored or cored, the size of the bore hole shall be limited to 2” larger than the pipe size being installed. Care shall be taken to ensure that minimum grade is maintained on the sewer service.

### 3.4. WATER SERVICES

For connections made to the water main that are not made under city contract, all connections to water mains shall be made with a corporation stop furnished by the plumber and placed in the main by the City Water Department when it is desired to tap the water main.

For connections made to the water main under city contract, all materials and labor necessary to make the connection to the water main shall be furnished and installed by the Contractor at his expense.

All connections shall be laid in accordance with the ordinances of the City of Fargo and Water Department regulations governing the same. The water service line shall be laid in a wavy line in the trench and shall be of a length of at least 2 feet longer than the distance from the corporation to the curb stop. Tracer wire shall be securely fastened to the service laterals with tape or plastic ties at a minimum of 10 foot intervals. In addition, tracer wire shall be secured within 1 foot of all underground utility appurtenances. Water service pipes shall be installed as one continuous piece from the corporation stop to the curb stop and one continuous piece from the curb stop to the plug or one continuous piece from the curb stop to the connection to the existing service. At connections and fittings, use a plastic pipe cutter to ensure square (90 degree) and clean cuts for PEX pipe. Water services shall not be less than 7 1/2 feet below the finished street grade.

When connections are made to cast iron or ductile iron water main, the copper tubing shall be wrapped with polyethylene or dielectric tape for a minimum clear distance of 3 feet away from the main.

The water service pipe shall be looped at a 45-degree angle at the main into a gooseneck that shall be supported from displacement and settlement to prevent strain. The curb stops and curb boxes shall be furnished by the Contractor and shall be located and set as shown on the plans and details, as staked in the field and set to mid-height of adjustment. Any extensions required to achieve this shall be made with threaded couplers; no bolt-on extensions will be allowed.

As soon as the connection to the main is completed and prior to backfill, the corporation shall be opened and the connection examined for defects. All connections on the non-tested side of the curb stop or service valve shall pass visual inspection under city pressure by the Engineer in the field prior to backfilling. For new construction projects, if dry tap connections are made the water service shall be installed and backfilled as the water main is installed and backfilled.

All water services shall be pressure tested with the main. For new construction projects, the curb stops shall be open and the water services shall be pressure tested from the main to a Contractor supplied cap or plug at the end of the service.

The City Water Department will be checking all curb stop boxes for height adjustment and straightness at the end of the project. If defects are discovered, the Contractor shall make necessary repairs at his expense.

#### 3.4.1. Bored Water Services

When water services are bored or cored, the size of the borehole shall be limited to 2" larger than the pipe size being installed.

#### 3.5. RIGHT OF PROPERTY OWNER TO INSTALL SERVICE

Property owners have the legal right, within a specified period, to cause sewer and water connections to be made as required by these Specifications, and reductions in the quantities may therefore result.

#### 3.6. RECORDS TO BE KEPT

As soon as the sewer and water pipe have been properly laid in place and connections made, the length, depth, and location of the service pipe shall be ascertained and a record made by the Engineer. No work shall be paid for unless such measurements have been made.

3.7. FINAL INSPECTION

The Contractor and the City of Fargo representative will operate all main valves and inspect all stop boxes for access. This procedure will be accomplished after all clean up, etc. has been completed. This inspection will be made prior to the final payment for work performed. Any defects shall be promptly repaired by the Contractor at his cost.

**PART 4**  
**GUARANTEE, MEASUREMENT & PAYMENT**

4.1. GUARANTEE

The guarantee shall be per the contract.

4.2. MEASUREMENT AND PAYMENT

All costs for removal of replaced materials shall be included in the contract unit price of the material being installed as the replacement.

*4.2.1. GENERAL*

The cost of excavation, trenching, and backfill shall be included as part of this specification.

*4.2.2. SEWER SERVICES*

The Contractor will not be paid for any sewer service repairs which are caused by his carelessness and/or negligence.

4.2.2.A. Pipe will be paid at the contract unit price per linear foot installed, including riser length if applicable, and will be measured from the center of the sewer main to either the point of connection to the existing service line or the end of the new service line. The contract unit price for service pipe shall include all costs for required bends.

1. Bored Sewer Services: The contract unit price for boring shall include the cost of the bore and the pipe/tubing for the length of the bore. Where services shown to be open-cut on the plans are bored as a more feasible option, payment will be made on the open-cut bid item.

4.2.2.B. Sewer service connections will be paid as follows:

1. New construction: The connect sewer service bid item shall include all costs to furnish and install the in-line wye, plug, and marker.



2. Sewer main replacement without service line replacement: The connect sewer service bid item shall include all costs to furnish and install an in-line wye, a short piece of new service pipe between the existing service pipe and the new in-line wye, and an approved coupler to connect the existing service line to the short piece of new service pipe.
3. Sewer service replacement without sewer main replacement: The connect sewer service bid item shall include all costs to furnish and install a new PVC saddle wye and an approved coupler to connect the existing service line to the new service line.
4. Sewer service replacement with sewer main replacement: The connect sewer service bid item shall include all costs to furnish and install a new in-line wye and an approved coupler to connect the existing service line to the new service line.

#### 4.2.3. WATER SERVICES

4.2.3.A. Pipe/tubing will be paid at the contract unit price per linear foot, and will be measured in a straight line horizontally from the centerline of the water main to either the point of connection to the existing service line or the end of the new service line. No additional footage will be added to install the service in a wavy line.

1. Bored Water Services: The contract unit price for boring shall include the cost of the bore and the pipe/tubing for the length of the bore. Where services shown to be open-cut on the plans are bored as a more feasible option, payment will be made on the open-cut bid item.

4.2.3.B. Water service connections will be paid per each and shall include the following:

1. New construction: The connect water service bid item shall include all costs to furnish and install the stainless steel saddle and corporation stop. The curb stop and box bid item shall include all costs to furnish and install the curb stop, curb stop box, markers, and cap or plug.

2. Water main replacement: The connect water service bid item shall include all cost to furnish and install the stainless steel saddle, corporation stop, and any service fittings necessary to reconnect the existing water service. If the existing water service is shown to be replaced from the main through the curb stop, the curb stop and box will be paid for under the curb stop and box bid item.

On city contracts, the Contractor shall perform all live taps for services 2" and smaller. For live service taps larger than 2" only the City Water Department will be allowed to perform the tap unless authorized by the City Water Department Supervisor.

For live service taps larger than 1" that are not made under city contract, only the City Water Department will be allowed to perform the tap and the Contractor will be billed for the tap by the City Water Department.

The tracer wire and tracer wire accessories, electrical conductivity testing, and pressure testing shall be considered incidental to water service construction.

#### *4.2.4. OTHER COSTS*

All other costs for work necessary to properly complete the work specified herein shall not be bid items; the costs shall be charged to other items unless a bid item is specifically included on the bid sheet.

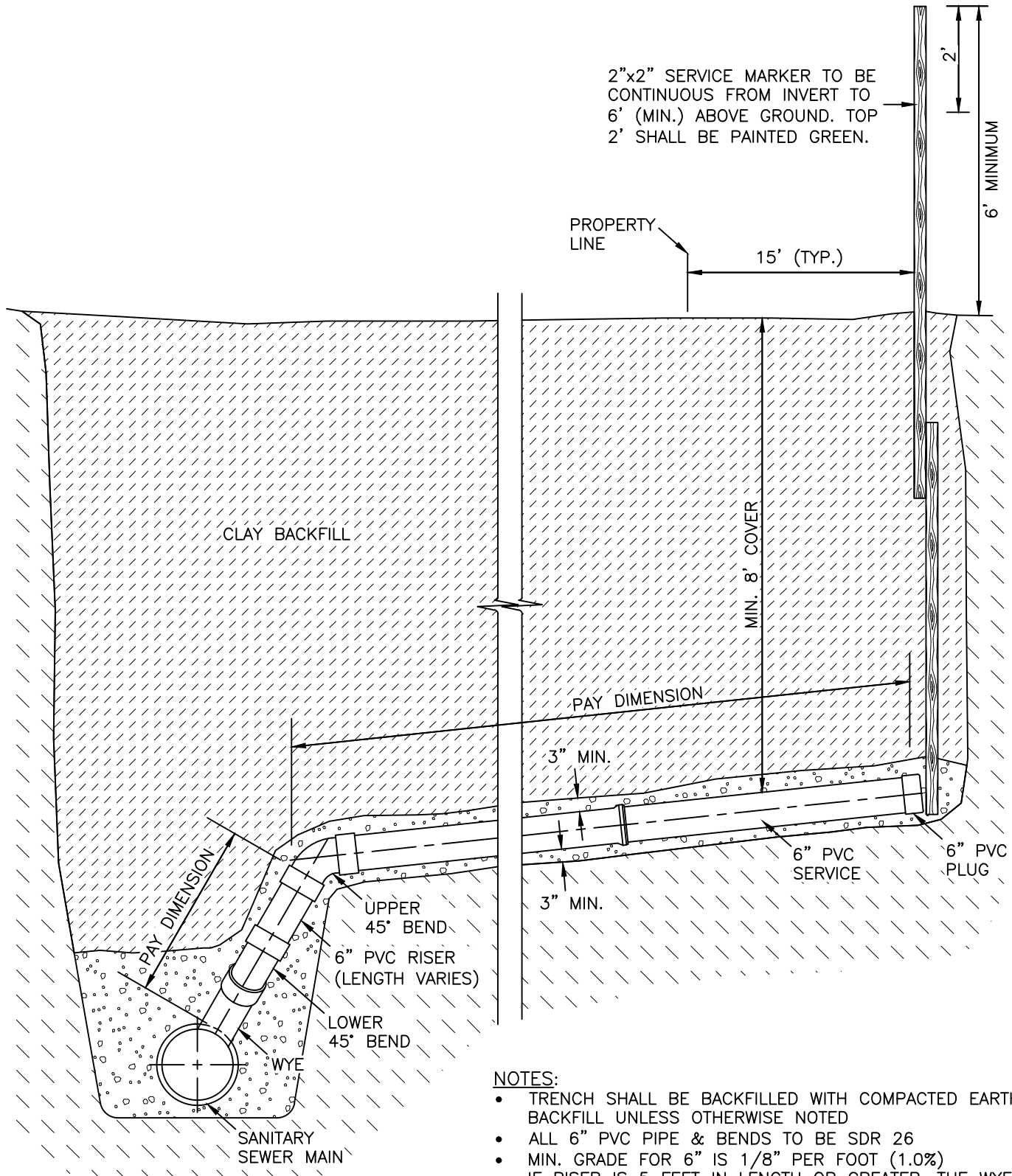

**NOTES:**

- TRENCH SHALL BE BACKFILLED WITH COMPACTED EARTH BACKFILL UNLESS OTHERWISE NOTED
- ALL 6" PVC PIPE & BENDS TO BE SDR 26
- MIN. GRADE FOR 6" IS 1/8" PER FOOT (1.0%)
- IF RISER IS 5 FEET IN LENGTH OR GREATER, THE WYE, WYE BEND, AND LOWER BEND SHALL BE SUPPORTED WITH 1-1/4" CRUSHED ROCK ENCASEMENT



SECTION: 1400	DRAWING: 5.1
REVISION: 2019	
<b>SANITARY SERVICE FOR NEW INSTALLATION</b>	
APPROVED:	DATE:

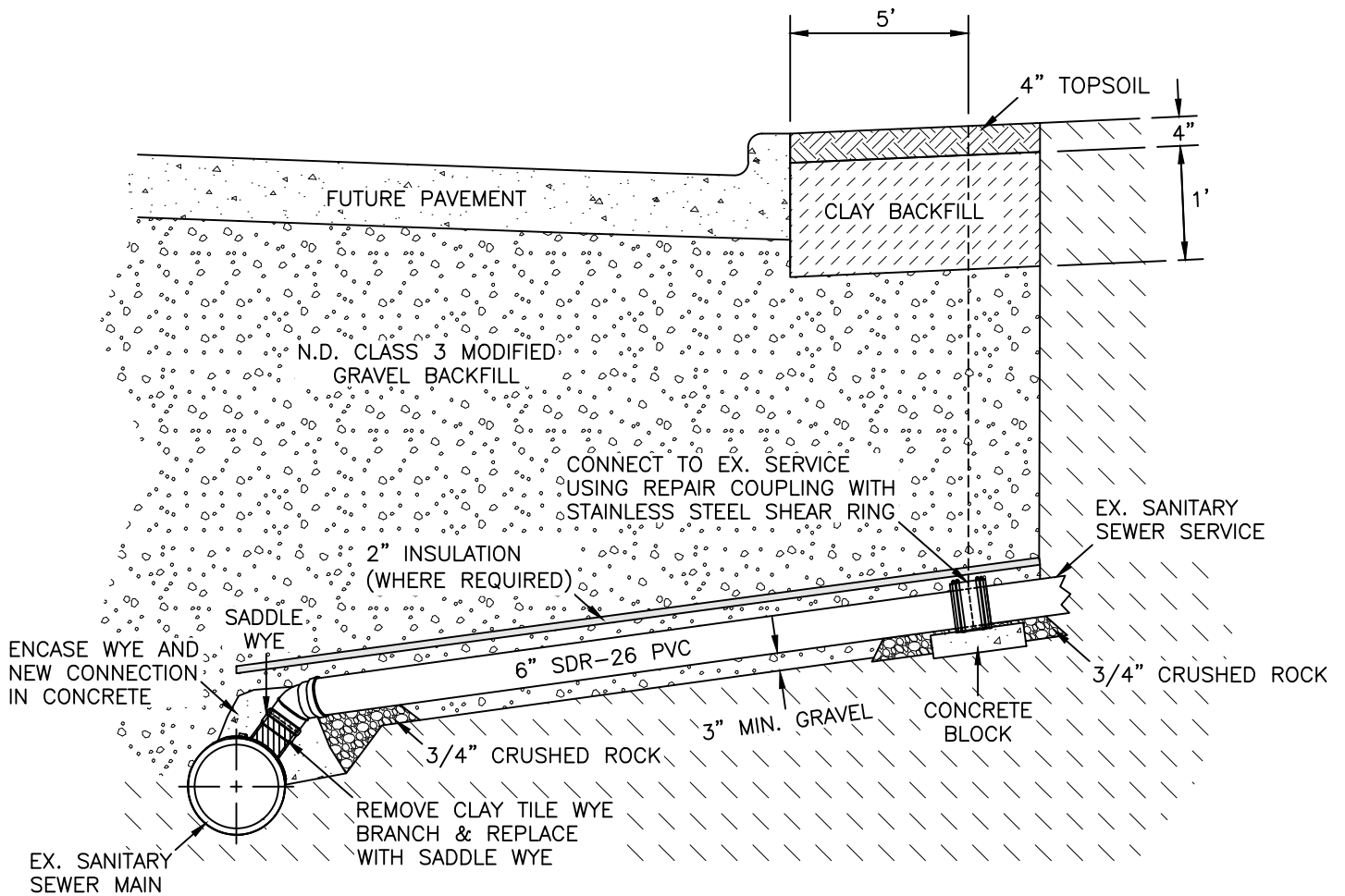

**NOTES:**

- INSULATION REQUIRED WHERE SERVICE IS LESS THAN 7' DEEP.
- PIPES SHALL BE BUTTED TOGETHER WITH REPAIR COUPLING CENTERED ON BUTT-JOINT.
- INSTALL 12" CLAY CAP BELOW FUTURE AGG. BASE IF SERVICE IS INSTALLED UNDER FUTURE PAVING WITH EDGE DRAIN.

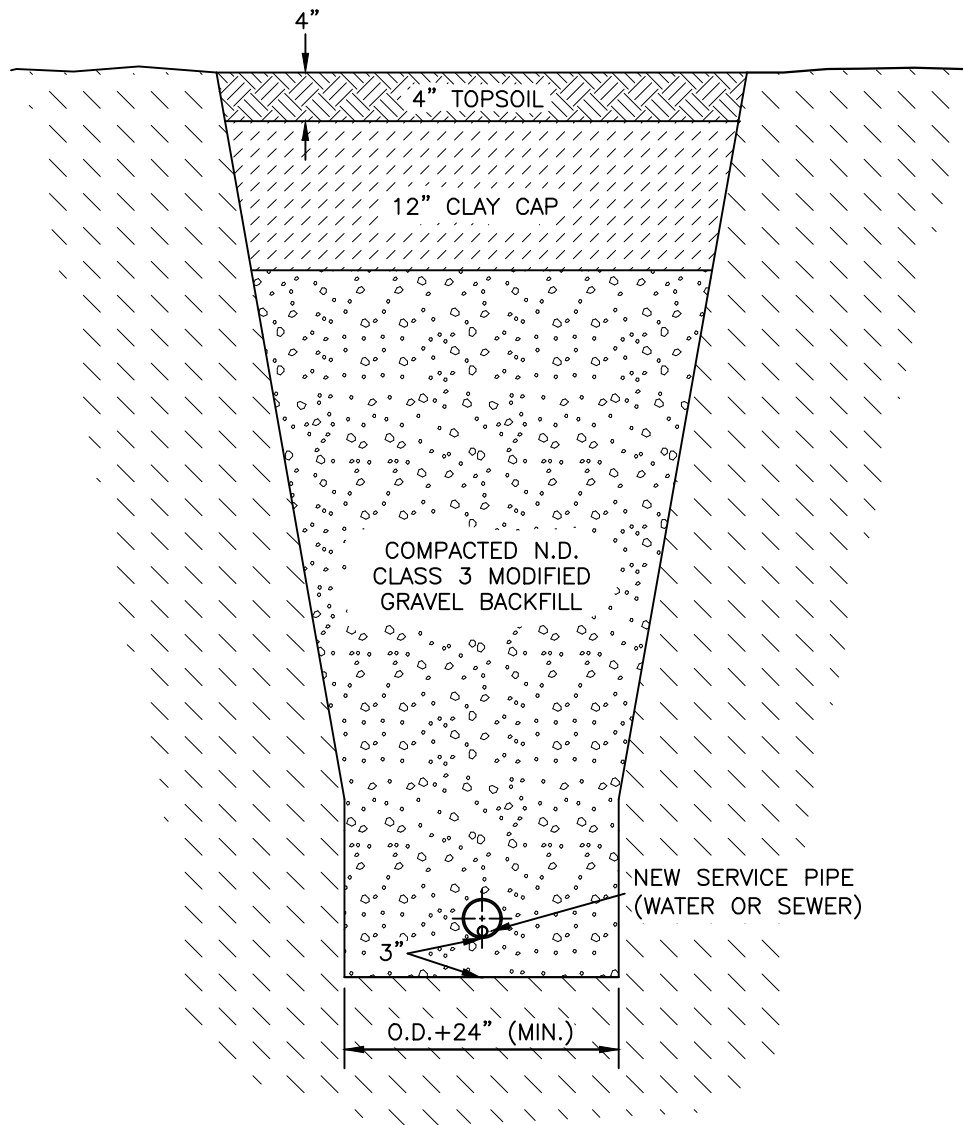

**NOTES:**

- THIS DETAIL APPLIES IN REHABILITATION AREAS WHERE WATER OR SEWER SERVICE IS REPLACED BETWEEN THE CURB AND PROPERTY LINE.
- FOR SANITARY SEWER SERVICE TRENCH UNDER CONCRETE ROADWAY SEE SECTION 1200 DETAILS.
- FOR WATER SERVICE TRENCH UNDER CONCRETE ROADWAY SEE SECTION 1300 DETAILS.

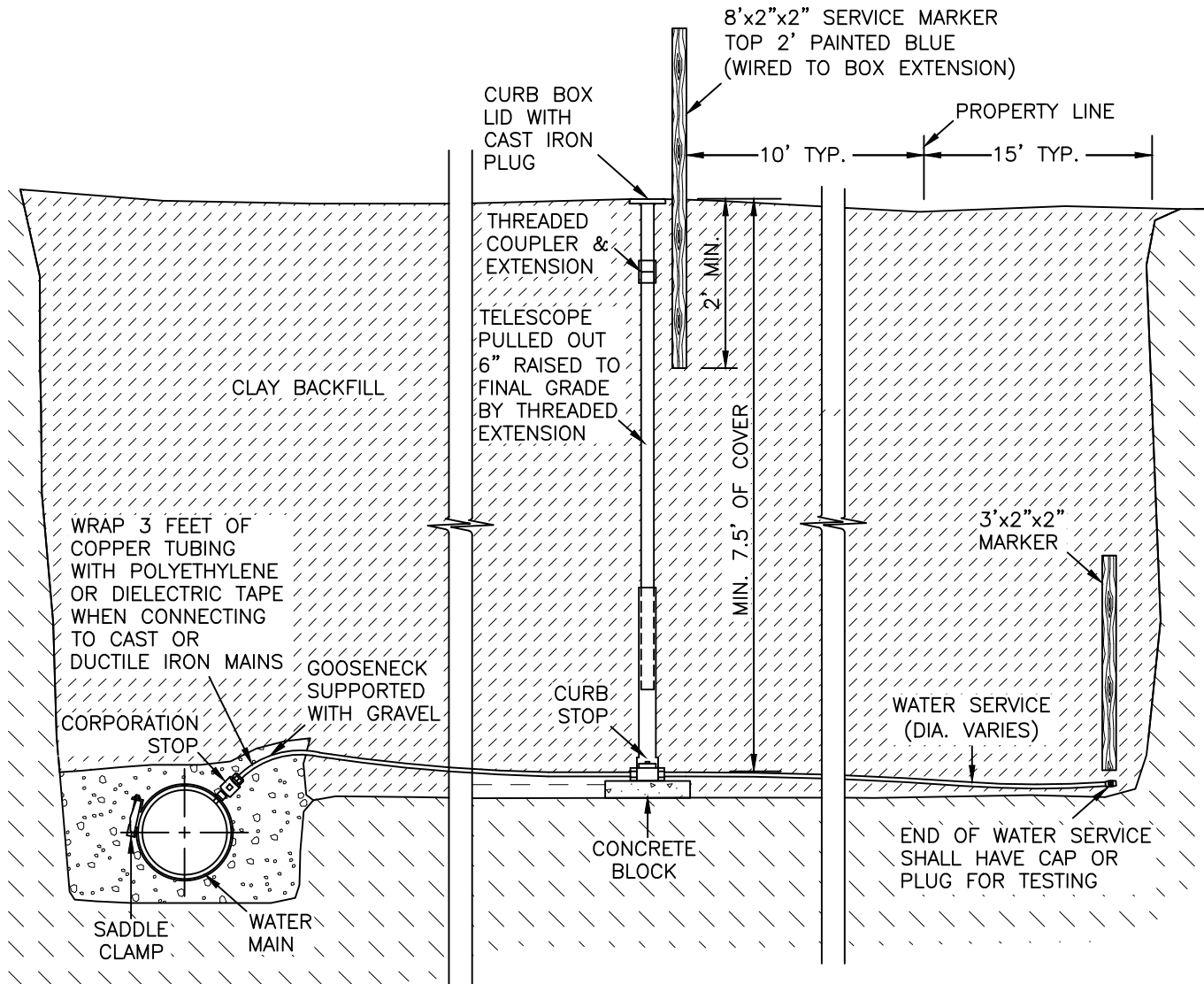

**NOTES:**

- CURB STOP SHALL BE PLACED ON CONCRETE BLOCK ON UNDISTURBED GROUND
- STOP BOX TO BE INSTALLED ALONG SIDE OF TRENCH AND SUPPORTED TO THE TRENCH WALL WITH TWO WOODEN BRACES TO PROVIDE SUPPORT DURING BACKFILL.
- REFER TO DETAIL 1400-5.6 FOR TRACER WIRE AND TRACER WIRE ACCESS POINT DETAILS.

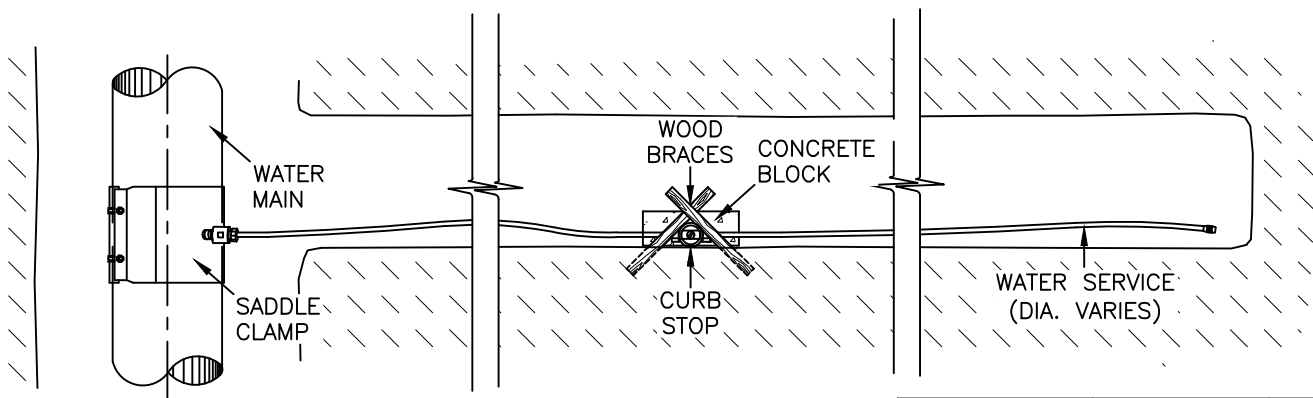

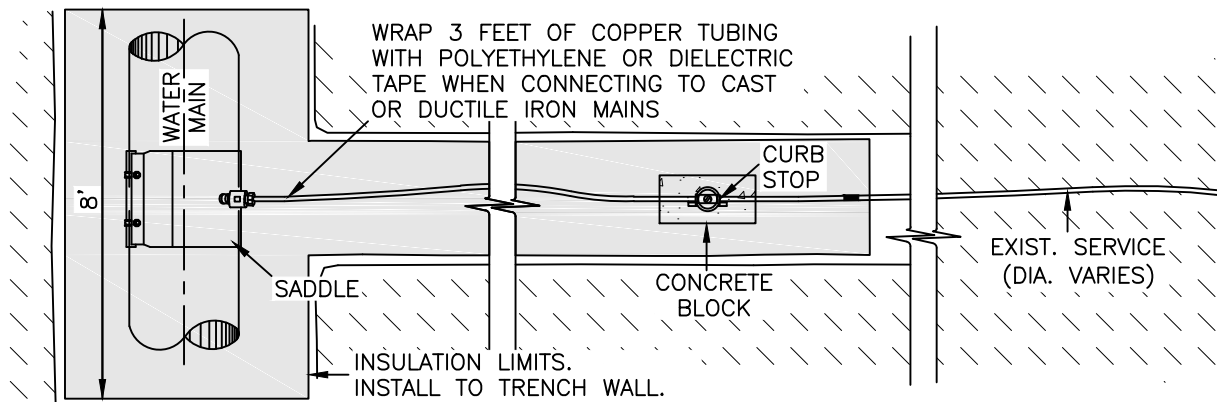
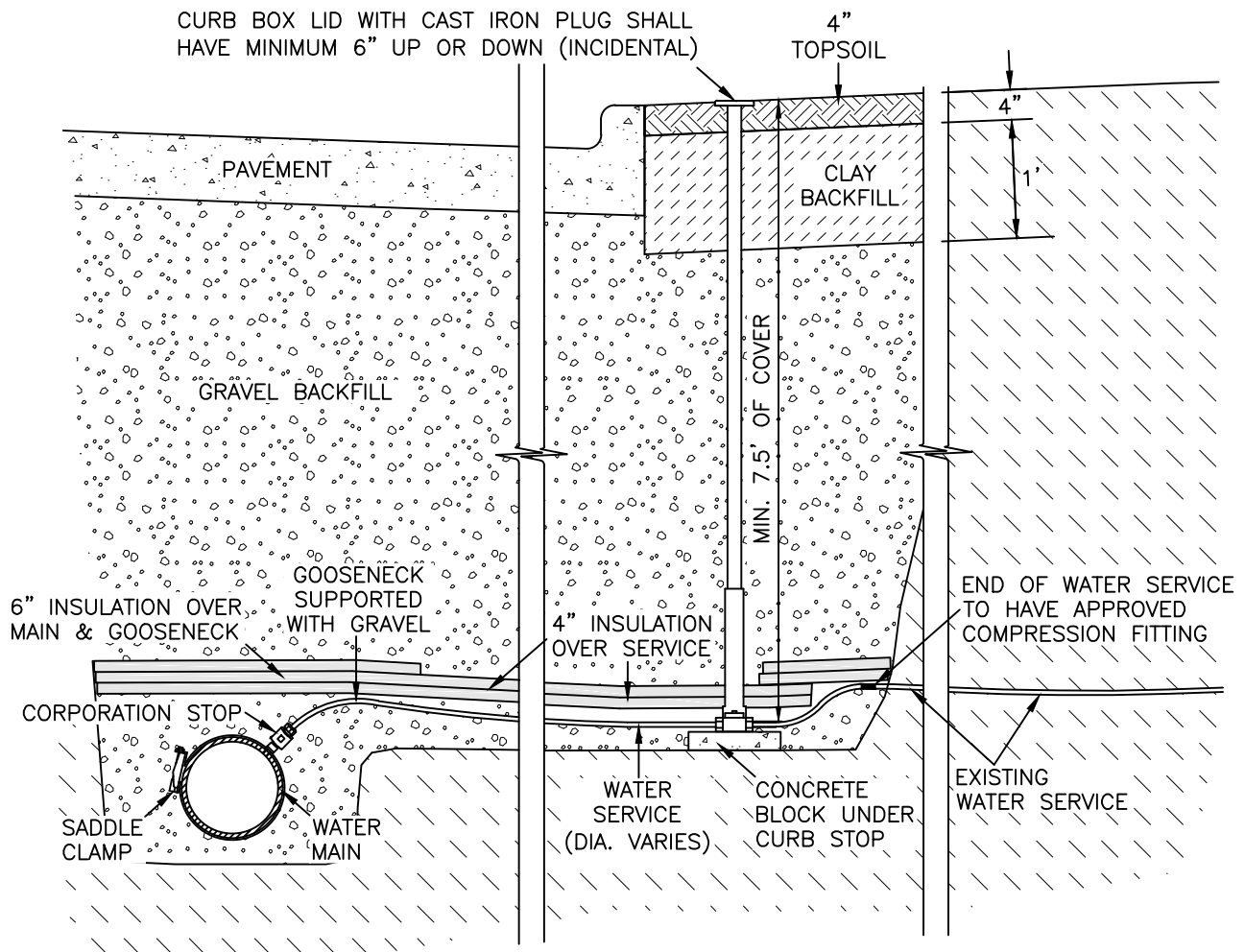

**NOTES:**

- CURB STOP TO BE PLACED ON A CONCRETE BLOCK.
- ALL INSULATION IS INCIDENTAL TO SERVICE PIPE.
- ALL INSULATION BOARDS SHALL BE 2" THICK, STACKED TO ACHIEVE TOTAL THICKNESS DESIRED.
- WHEN STACKING INSULATION BOARDS, STAGGER EACH LAYER SUCH THAT ALL BUTT JOINTS ARE OVERLAPPED BY THE LAYER ABOVE.
- REFER TO DETAIL 1400-5.7 FOR TRACER WIRE AND TRACER WIRE ACCESS POINT DETAILS.
- INSTALL 12" CLAY CAP BELOW FUTURE AGG. BASE IF SERVICE IS INSTALLED UNDER FUTURE PAVING WITH EDGE DRAIN.

**NOTES:**

- LATERAL TRACER WIRE FOR WATER SERVICES SHALL BE SECURED TO THE WATER SERVICE PIPE WITH TAPE OR PLASTIC TIES AT A MAXIMUM OF 10 FOOT INTERVALS. IN ADDITION, LATERAL TRACER WIRE SHALL BE SECURED WITHIN 1 FOOT OF ALL UNDERGROUND UTILITY APPURTENANCES.
- LATERAL TRACER WIRES SHALL BE A SINGLE WIRE, CONNECTED TO THE MAINLINE TRACER WIRE USING AN APPROVED CONNECTOR, INSTALLED WITHOUT CUTTING/SPLICING THE MAINLINE TRACER WIRE.

APPROVED TRACER WIRE ACCESS BOX SECURED TO 8'x2"x2" SERVICE MARKER ABOVE EXISTING GROUND ELEVATION. CONTRACTOR SHALL LEAVE 24" OF TRACER WIRE WIRE SLACK INSIDE TRACER WIRE ACCESS POINT.

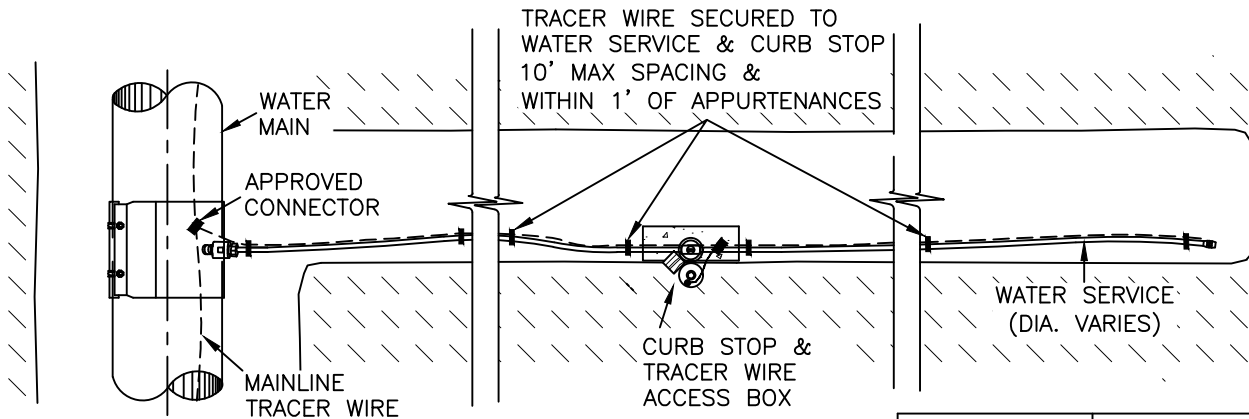
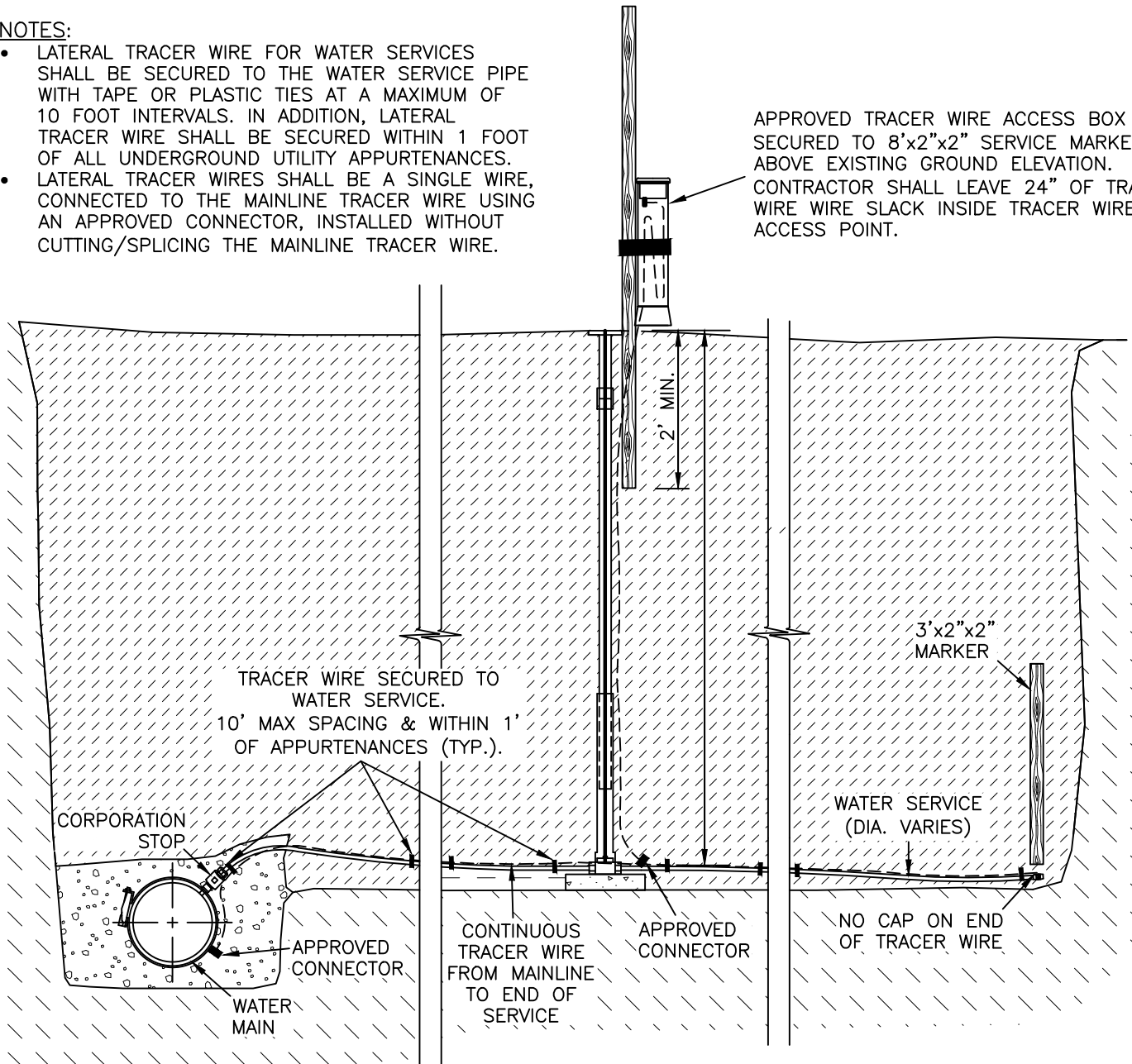



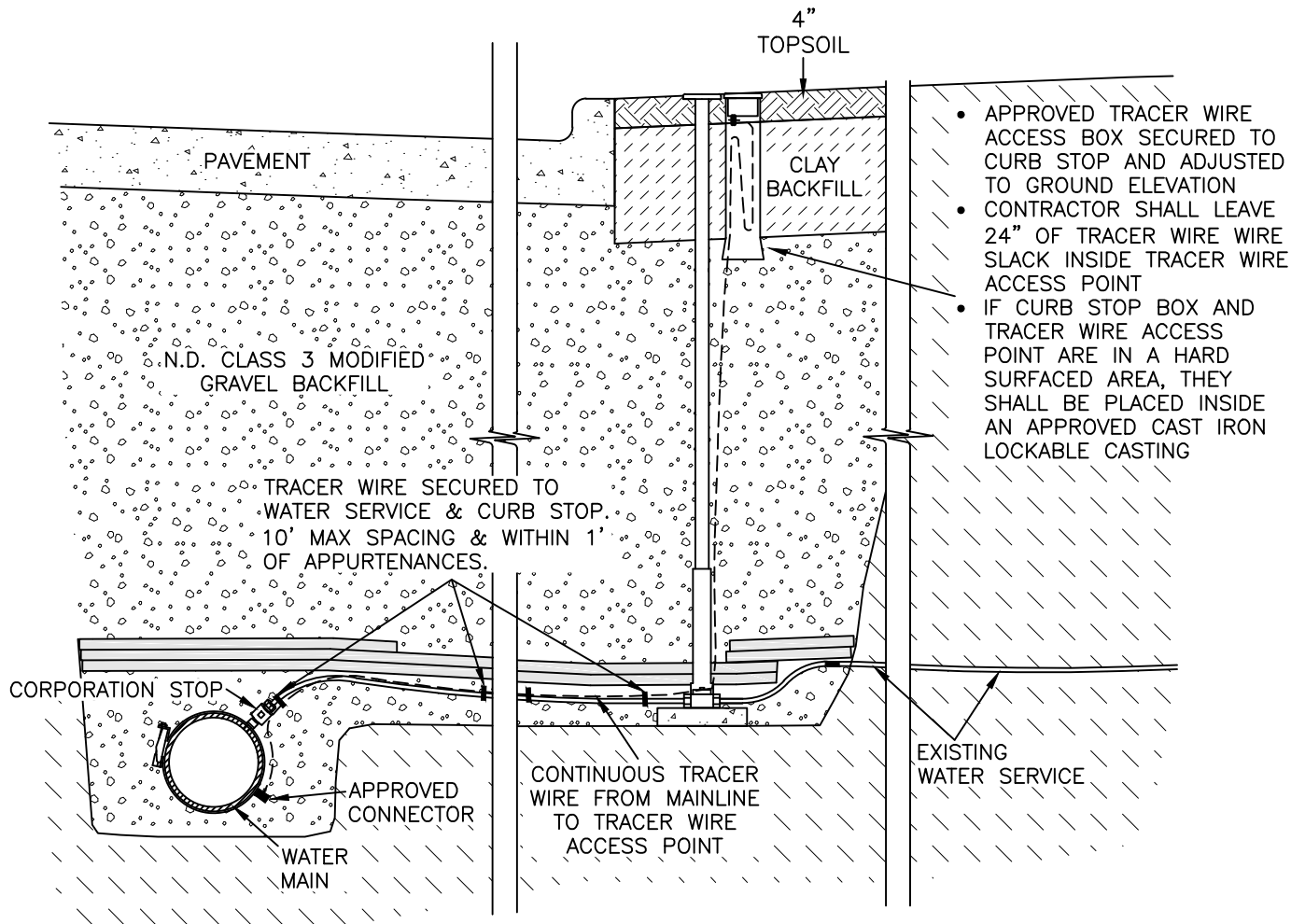

- APPROVED TRACER WIRE ACCESS BOX SECURED TO CURB STOP AND ADJUSTED TO GROUND ELEVATION
- CONTRACTOR SHALL LEAVE 24" OF TRACER WIRE WIRE SLACK INSIDE TRACER WIRE ACCESS POINT
- IF CURB STOP BOX AND TRACER WIRE ACCESS POINT ARE IN A HARD SURFACED AREA, THEY SHALL BE PLACED INSIDE AN APPROVED CAST IRON LOCKABLE CASTING

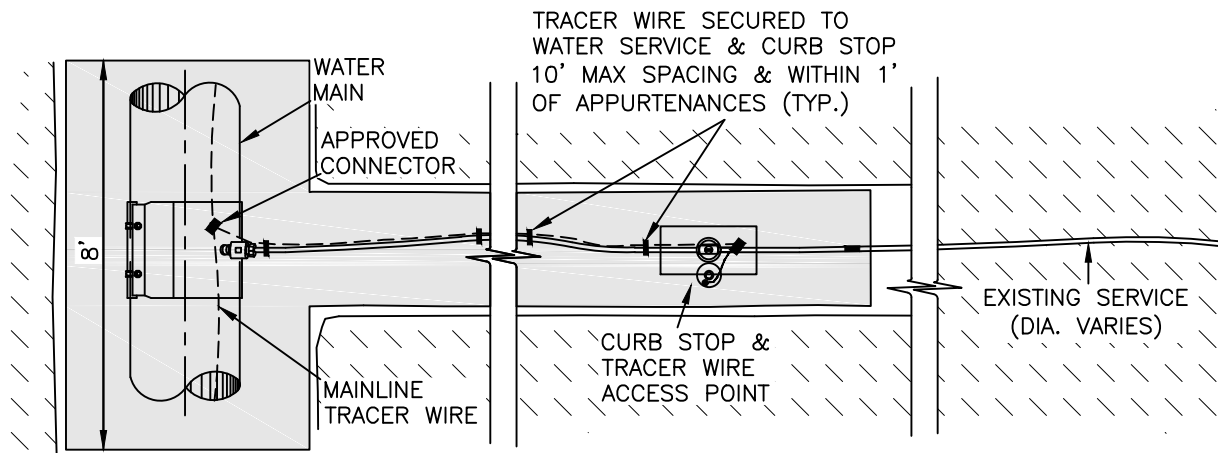

**NOTES:**

- LATERAL TRACER WIRE FOR WATER SERVICES SHALL BE SECURED TO THE WATER SERVICE PIPE WITH TAPE OR PLASTIC TIES AT A MAXIMUM OF 10 FOOT INTERVALS. IN ADDITION, LATERAL TRACER WIRE SHALL BE SECURED WITHIN 1 FOOT OF ALL UNDERGROUND UTILITY APPURTENANCES.
- LATERAL TRACER WIRES SHALL BE A SINGLE WIRE, CONNECTED TO THE MAINLINE TRACER WIRE USING AN APPROVED CONNECTOR, INSTALLED WITHOUT CUTTING/SPLICING THE MAINLINE TRACER WIRE.



SECTION: 1400	DRAWING: 5.7
REVISION: 2019	
<b>REPLACEMENT W.S. TRACER WIRE DETAIL</b>	
APPROVED:	DATE:

**CITY OF FARGO SPECIFICATIONS  
STORM SEWERS**

**PART 1  
DESCRIPTION OF WORK**

The work to be done under this section of the Specifications and the accompanying plans consists of the furnishing of all labor, material, accessories and equipment necessary to construct storm sewers in the City of Fargo. The work includes excavation, removal and replacement of paving where encountered; furnishing, laying and jointing pipe; making connections to existing storm sewers and manholes and inlets as necessary; constructing new manholes and inlets; protecting existing utilities and public and private property; backfilling trenches and other work as may be necessary in order that the work may be completed in accordance with these Specifications and the plans accompanying them.

**PART 2**  
**MATERIAL**

2.1. REINFORCED CONCRETE PIPE (RCP)

*2.1.1. MATERIAL*

Material, manufacture and testing of RCP shall comply with ASTM C76 latest edition. RCP joints shall have rubber gaskets conforming to ASTM C 443.

*2.1.2. MANUFACTURE*

Pipe shall be furnished in four to eight foot lengths. Unless otherwise stated in the plans or special instructions, pipe 12" to 18" in diameter shall be Class V, 21" to 36" in diameter shall be Class III, 42" and larger diameter shall be Class II. All pipes shall be marked with the date of manufacture and class of pipe, and no pipe shall be laid before it is at least five days old. Special coatings or lining, if required, shall be as specified in the Special Instructions on the particular project.

*2.1.3. JOINTS*

Joints shall be of the tongue and groove type and shall be designed to be self-centering. Joints shall be furnished with an all weather butyl rubber gasket in flexible rope form meeting or exceeding the requirements of Federal Specification SS-S-210 A and AASHTO M-198. Where conditions warrant, an approved primer shall be used to obtain a sufficient seal, as directed by the Engineer. All lift holes shall be plugged with a nonshrink concrete plug and a mortar mix or asphaltic sealer to fill voids.

2.2. SOLID WALL POLYVINYLCHLORIDE (PVC) SEWER PIPE

*2.2.1. MATERIAL*

The material shall conform to "Standard Specifications for Rigid Polyvinyl chloride Compounds", ASTM D-1784, Class 12454-B or 12454-C or 12364-C. The pipe shall be produced using a continuous extrusion process employing a prime grade of unplasticized polyvinyl chloride.

### *2.2.2. PIPE MANUFACTURE*

The PVC sewer pipe and fittings 15 inches in diameter or smaller shall meet the requirements of ASTM D 3034 SDR 35 minimum; pipe and fittings larger than 15 inches in diameter shall meet the requirements of ASTM F 679, wall thickness T-1, pipe stiffness of 46 psi.

### *2.2.3. JOINTING*

The joint system shall be an integral bell gasketed joint, which forms a watertight seal.

## *2.3. POLY VINYL CHLORIDE (PVC) RIBBED SEWER PIPE*

### *2.3.1. MATERIAL*

The material shall conform to “Standard Specifications for Rigid Polyvinyl chloride Compounds”, ASTM D-1784, Class 12454-B or 12454-C or 12364-C. The pipe shall be produced using a continuous extrusion process employing a prime grade of unplasticized polyvinyl chloride.

### *2.3.2. PIPE MANUFACTURE*

The PVC ribbed sewer pipe and fittings 30 inches in diameter or smaller shall be seamless profile wall and meet the requirements of ASTM F794 Standard Specification for PVC Ribbed Gravity Sewer Pipe and Fittings Based on Controlled Inside Diameter. The pipe interior shall be smooth walled and shall have a minimum pipe stiffness of 60 psi for pipe diameters 12 inches or less and a minimum pipe stiffness of 46 psi for 15-30” diameter pipe. Pipe shall meet requirements of ASTM D2444 for impact resistance. Exterior ribs shall be perpendicular to the axis of the pipe to allow placement of sealing gaskets without additional cutting or machining.

### *2.3.3. JOINTING*

The joint system shall be an integral bell gasketed joint, which forms a watertight seal and meets the requirements of ASTM D3212 and F477.

### *2.3.4. MARKING*

Each length of pipe shall be marked with the following information: Size, Company name or logo, PVC Sewer Pipe, ASTM F794 Manufacturers code, Cell Classification.

### *2.3.5. APPROVED MANUFACTURER*

PWEAGLE ULTRA-RIB is an approved product.

## 2.4. CLOSED PROFILE POLYVINYL CHLORIDE (PVC) SEWER PIPE

### *2.4.1. MATERIAL*

The pipe and fittings be made of PVC plastic meeting the requirements of ASTM D-1784 having a minimum cell classification of 12364 -A.

### *2.4.2. MANUFACTURE*

The PVC profile wall pipe and fittings shall meet the requirements of ASTM F 794 latest edition and have a minimum pipe stiffness of 46 psi. Closed cell PVC pipe will only be allowed in 21-inch diameter or larger.

### *2.4.3. JOINTING*

The joint system shall be of the bell and spigot type with a gasket that meets the requirement of ASTM D3212 & F477 to form a watertight seal. Gaskets shall be factory installed and chemically bonded to the bell end of the pipe. Field cuts and field installed gaskets shall be done in accordance with the manufacturer's instructions and his recommended equipment and materials.

### *2.4.4. APPROVED MANUFACTURERS*

Vylon High Capacity and Diamond Plastics Pro-21 closed profile PVC pipe are approved products.

## 2.5. POLYPROPYLENE (PP) PIPE

### *2.5.1. MATERIAL*

Polypropylene compound for pipe and fittings production shall be impact modified copolymer meeting the material requirements of ASTM F2736, Section 4, ASTM F2881, Section 5 and AASHTO MP-21-11, Section 6.1 for the respective diameters. Pipes shall have a min. stiffness of 46 psi – ASTM D2412.

### *2.5.2. MANUFACTURE*

Under 30 inch diameter pipe shall be dual-wall pipe, and shall have a smooth interior and annular exterior corrugations and meet or exceed ASTM F2736 and AASHTO MP-21-11.

30 to 60 inch diameter pipe shall be triple-wall pipe and shall have a smooth interior and exterior walls and meet or exceed ASTM F2881 and AASHTO MP-21-11.

### *2.5.3. JOINTING*

Pipe shall be joined with a gasketed integral bell & spigot joint meeting the requirements of ASTM F2736 & F2881, for the respective diameters.

All pipe joints shall be watertight according to the requirements of ASTM D3212. Spigots shall have gaskets meeting the requirements of ASTM F477. Gasket shall be installed by the pipe manufacturer and covered with a removable, protective wrap to ensure the gasket is free from debris. A joint lubricant, available from the manufacturer, shall be used on the gasket and bell during assembly.

Pipes shall have a reinforced bell with a polymer composite band installed by the manufacturer.

## 2.6. MANHOLES

### *2.6.1. MATERIAL*

Precast manholes shall meet the requirements of ASTM C478. Precast segmental blocks shall be manufactured in accordance with ASTM C-139. The blocks shall form an 8" wall thickness. Brick shall be clay or concrete, uniform in size and texture and meeting ASTM Specifications for sewer brick. Brick manholes shall have prior approval from the Engineer.

Either monolithic manhole style boot connectors factory installed at the proper elevation and direction or concrete to PVC pipe adapters shall be used to connect PVC pipe to the manhole. PVC manhole adapter shall be GPK Products or approved equal.

### 2.6.2. MANUFACTURE

The manholes shall be constructed in accordance with ASTM C478 and the detail drawings included as part of this section of the Specifications. The main sewer shall be carried through manholes by split pipe whenever practicable. The concrete manhole shelves shall slope from the top edges of the invert at a rate of 2" per foot. When split pipe is not possible due to breaks in grade or elevation, the sewer invert shall be made of concrete. The shape of the invert shall conform exactly to the lower 1/2 of the pipe it connects and be left smooth and clean. Side branch inverts shall be constructed with as large radius of curvature as possible.

Mortar for concrete block manholes shall be mixed in the proportions of one part by volume of Portland Cement and two parts by volume of sand. Cement and sand shall be thoroughly mixed dry and only enough water added to form a mortar of proper consistency for block laying. All mortar shall be used within 40 minutes of mixing, and all mortar that has begun to take on its initial set shall be discarded and shall not be mixed with additional cement or new mortar. When connecting pipe to manholes, regular concrete (not grout) shall be used to mortar around the pipes on both the inside and outside of the manhole or inlet.

### 2.6.3. JOINTS

Joints shall be of the tongue and groove type and shall be designed to be self-centering. Joints shall meet the requirements of ASTM C990 unless otherwise specified in the Special Instructions. Joints shall be an all weather butyl rubber gasket in flexible rope form, meeting or exceeding the requirements of federal specification 55.5-210A and AASHTO M-198. Where conditions warrant, an approved primer shall be used to obtain a sufficient seal as directed by the Engineer.

### 2.6.4. MANHOLE AND INLET ADJUSTING RINGS

Manhole and inlet adjusting rings shall be composed of engineered polymer; either injection molded High Density Polyethylene (HDPE) as manufactured by Ladtech, Inc., or IPEX, Inc, or Expanded Polypropylene (EPP) as manufactured by JSP, or approved equal. Fine adjustments shall be made with thin and/or tapered adjustment rings (no steel shims allowed). All rings shall meet or exceed AASHTO HS-20 loading and be properly installed and sealed in accordance with the manufacturer's recommendations. HDPE materials shall conform to ASTM D-4976 using 100% recycled material.

Precast reinforced concrete adjusting rings will only be allowed upon the Division Engineer's approval where the size required is not manufactured in engineered polymer.

#### *2.6.5. LIFT HOLES*

Lift holes shall be manufactured to provide a watertight seal.

### 2.7. INLETS

The inlets shall be constructed in accordance with the detailed drawings included as part of these Specifications. Concrete and reinforcing used in the construction of these inlets shall also meet the requirements of ASTM C-478.

Concrete to PVC pipe adapters shall be used to connect PVC pipe to the inlet. PVC manhole adapter shall be GPK Products or approved equal.

All gutter-line inlets shall be installed complete with holes, either precast or core-drilled, and boots for watertight edge drain connections. Boots shall be flexible synthetic rubber, certified to ASTM C-923, with no plastic parts, welds, nor rivets. Any/all fastening components shall be stainless steel.

### 2.8. CASTINGS

#### *2.8.1. MANHOLE CASTINGS*

Manhole casting shall be Neenah R-1733, EJ1205Z, or approved equal with a vented lid with the word "STORM" (or the words "STORM SEWER") cast into the center of the lid in letters at least 1 inch high.



2.8.2. *INLET CASTINGS*

RDI - Round Inlet  
SPI - Special Inlet

DBI - Double Box Inlet  
SBI - Single Box Inlet

MHI - Manhole Inlet

**CHART 1 - INLET CASTINGS, GRATES, ETC.**

Curb Type	Inlet Location	Inlet Type	Frame Type		Grate Type		Curb Box		Fargo Designation
			Neenah Foundry	EJ	Neenah Foundry	EJ	Neenah Foundry	EJ	
Standard (Type 2)	Low Point	DBI	R-3295-2	7031	V	M4	3290-0040	T5	DBI-V2
	Low Point	SBI	R-3067-VB	7030	VB	M11	3290-0040	T5	SBI-VB2
	Not LPT	SBI	R-3067-V	7030	V	M4	3290-0040	T5	SBI-V2
	Any	RDI or SPI	R-3404	5113	L	M1	none	none	RDI-L2 or SPI-L2
Mountable (Type 1)	Any	SBI	R-3067-C	7030Z2	L	M6	none	none	SBI-L1
	Any	RDI or SPI	R-3404	5113	L	M1	none	none	RDI-L1 or SPI-L1
Flat	ADA Ramp	SBI	R-3067-C	7030Z2	Q	M10	none	none	SBI-Q
none	Non-Street	RDI, SPI, or MHI	none		R-4342	6489	N/A		RDI, SPI, or MHI

Note: Gutter line MHI frame, grate, and curb box designations shall be as shown on the plans.

2.8.3. *BEEHIVE CASTING (WHERE SPECIFIED)*

Beehive casting (6" high) shall be Neenah R-2561-A, EJ 1205Z/M2 or approved equal.

2.8.4. *FLOATING CASTINGS (WHERE REQUIRED)*

Floating casting shall be per section 2100 of these Specifications.

**PART 3**  
**CONSTRUCTION**

3.1. GENERAL

Excavation, trenching and backfilling shall be done in accordance with Section 1000 of these Specifications. Pipe shall be handled and laid in accordance with the Manufacturer's or Industry standards, ASTM C1479. Pipe and manholes shall be laid in the location shown on the plans, the exact location being designated by the Engineer. With PVC and/or PP pipe, both ends shall be wiped clean and sufficient lubrication placed on the gasket and spigot end before the pipe is fully pushed into the bell. Field cut spigot ends shall be beveled prior to being pushed into the bell. With RCP, both ends shall be cleaned and the asphaltic joint sealer applied in sufficient quantity to be extruded from the joint as the pipe is pushed home. If butyl rubber gaskets are used, they shall be installed as per the manufacturer's recommendations. Every part of the pipe shall be bedded uniformly throughout its length. Pipe shall be laid upgrade with the spigot end pointing in the direction of flow. All sewers must be kept thoroughly clean. When the trench is left at night or the pipe laying stopped, the upper end of the pipe must be closed with an end board or cap to prevent dirt and sand from entering the pipe.

Pipe shall not be trimmed except for closures, and pipe not making a good fit shall be plainly marked and removed from the site. Permissible defects (minor chips or broken sockets with a depth of fracture less than 1" deep as measured from the end of the socket (RCP only)) shall be placed in the top of the line.

PVC and/or PP pipe used as storm sewer will only be allowed on backyard inlet lead runs where the pipe is located outside the future street section unless approved by the Engineer. Material change can only be made at a structure.

All 60" or larger RCP shall be laid on a bed of 6-inches of 1 1/4" crushed rock. The six inches of crushed rock shall be incidental to the pipe bid price. Additional rock shall be used as directed by the Engineer to backfill unstable bedding areas. The cost of excavating and placing the additional (more than 6-inches) shall be paid for per cubic yard of 1 1/4" crushed rock.

### 3.2. ALIGNMENT

The Engineer will provide line and grade for all storm sewer pipes. Grade and alignment shall be maintained by the use of a line parallel to the grade and line of the sewer, this line to be supported above the ground on batter boards spaced 50 feet or less apart and rigidly anchored to and supported by steel post driven into the ground.

Not less than 3 batter boards shall be maintained at all times. The Engineer shall be immediately notified of any misalignment of the batter boards set in accordance with the grade and alignment of the tacked offset stakes provided.

Electronic grade control is allowed, however the Contractor will be required to periodically check the alignment and grade from the offset stakes provided. In no instance will the Contractor be allowed to change the alignment or grade without the permission of the Engineer.

### 3.3. MANHOLES/INLETS

The manhole/inlet bases shall be set at the proper grade and alignment to provide a smooth transition from the incoming pipe(s) to the outgoing pipe. Manhole/inlet bases shall be set on four inches of bedding sand in a dry trench condition. In wet or unstable trench conditions the manhole/inlet base shall be bedded in 6" of 1 1/4" crushed rock. The area that is over-excavated adjacent to the manhole/inlet base and under the pipe shall be filled with concrete to prevent settlement and provide for support for the pipe from the manhole/inlet edge to the regular trench excavation. Care shall be taken that the connection between the manhole/inlet and the pipe is watertight and the invert is smooth and continuous as it enters and exits the manhole/inlet. Mortar around the pipe connection shall be regular concrete (not grout) conforming to the requirements for sidewalks outlined in Section 2300. The concrete shall be placed on both the inside and outside of the manhole/inlet concurrently. The concrete below the spring line of the pipe at both the exterior and interior of the manhole/inlet shall be vibrated. The interior shall have a wood trowel finish. When non-RCP is used, a manhole connection adapter will be required to be installed to achieve a watertight condition - installation shall be per the pipe manufacturer recommendations. Contractor shall protect manhole/inlet from washouts by plugging holes for edge drain. If edge drain is not part of the contract, plugs shall remain in place at completion of project.

### 3.4. CASTING TO GRADE (BOULEVARD)

This item applies to inlets located outside the paving section and for manholes/inlets that will not be adjusted with a planned future project, and shall include all labor, materials and equipment necessary to

adjust the various manhole/inlet castings to the proper line and grade. Changes in grade shall be made as follows:

All adjustments, including fine adjustments, shall be made with engineered polymer adjustment rings as specified herein (no steel shims allowed). All adjustment rings shall be properly sealed or wrapped with nonwoven geotextile fabric in accordance with the manufacturer's recommendations.

Where casting adjustment requirements cannot be met by the use of engineered polymer adjustment rings and upon the Division Engineer's approval, the Contractor shall provide precast reinforced concrete adjusting rings. For fine adjustments of less than two (2) inches, steel shims shall be used to temporarily support the casting. The castings and rings shall be laid in a full bed of mortar. The rings and structure section shall be cleaned to assure a flat seating surface and the rings shall be installed in alignment with no noticeable offsets. After smoothing the protruding grout around the interior and exterior of the rings, nonwoven geotextile fabric shall be placed and secured around the outside of the rings from three (3) inches below the top of the manhole/inlet structure to the top of the rings, overlapping the frame casting.

Care shall be taken to adjust the casting to the elevation determined by the Engineer. Any castings not satisfying these requirements shall be redone to the satisfaction of the Engineer.

### 3.5. TELEVISIONING

All gravity sewers shall be televised by the City of Fargo Street Department. Any abnormalities such as, but not limited to, deviations of grade, misaligned joints, cracked/defected pipe, rolled gaskets shall be repaired by the Contractor at his expense. Sections requiring repair shall be re-televised to verify conditions of repair. It is the Contractor's responsibility to provide drivable access to each manhole for the City of Fargo camera truck. Televising requires a 7-day advance notice and shall be scheduled through the inspectors on site, and will be completed during normal City of Fargo Street Department hours. If the camera operator deems the pipe unsuitable for televising, the Contractor shall clean the sewer by means of jetting. All costs to accommodate televising shall be included in other bid items.

### 3.6. DEFLECTION TESTING

All flexible conduit pipe used in urban storm sewers shall be tested for deflection in accordance with Section 1200 of these Specifications.

**PART 4**  
**GUARANTEE, MEASUREMENT & PAYMENT**

4.1. GUARANTEE

The guarantee shall be per the contract.

4.2. MEASUREMENT AND PAYMENT

*4.2.1. GENERAL*

The cost of excavating and trenching shall be included as part of this specification.

*4.2.2. STORM SEWER PIPE*

Pipe will be measured by customary and conventional methods and paid for on a unit price basis for the actual length installed. Measurement will be from center of manhole to center of manhole or from end of existing pipe to center of manhole or end of pipe stubout. No additional payment will be made for the manhole connections or cutting of pipe for closures. Where bid items are provided, plugs will be paid on a per each basis, otherwise they shall be incidental to the work.

*4.2.3. STORM SEWER MANHOLES & INLETS*

The cost of furnishing and installing the manholes and inlets will be paid for on a lump sum bid per each manhole or inlet installed. Costs shall include all excavation, bedding, backfilling, constructing, furnishing and installing the casting in place, connections to the sewer, installing inverts and sealing the manhole or inlet connections, joints, and lift holes, and plugging the holes for edge drain.

*4.2.4. CASTING TO GRADE (BOULEVARD)*

This bid item shall be paid for at the contract unit price per each, and shall include adjusting the castings with up to 4 adjusting rings, including all sealant, wrap, or chimney seals as specified herein.

*4.2.5. FLARED-END SECTION (FES)*

The length of a Flared End Section (FES) shall not be included in the measurement of the associated storm sewer size. A FES shall be paid on a per each basis. Trash racks shall be incidental to the FES bid item.

*4.2.6. OTHER COSTS*

All other costs for work necessary to properly complete the work specified herein shall not be bid items; the costs shall be charged to other items unless a bid item is specifically included on the bid sheet.

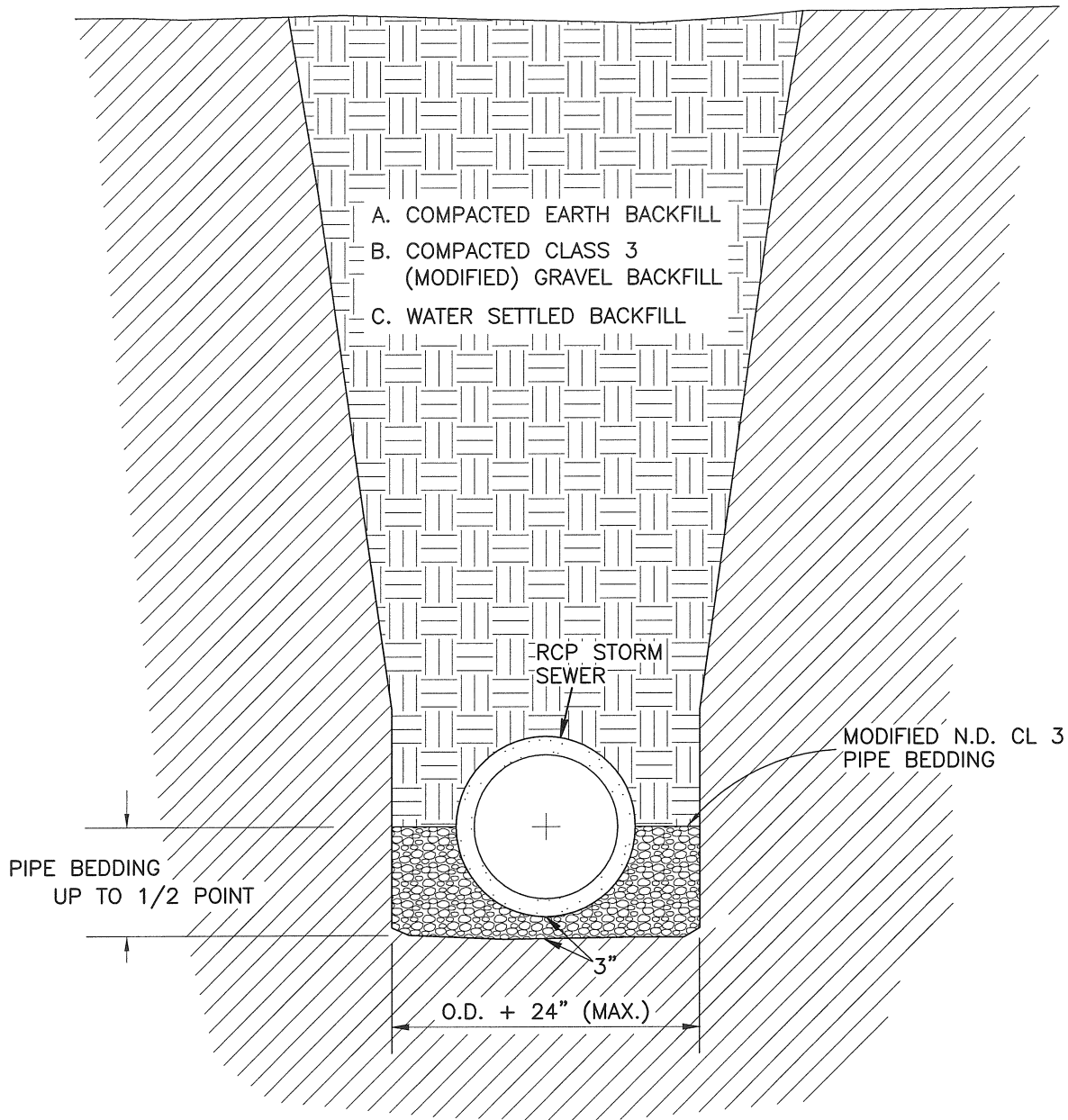

NOTES:

1. MAXIMUM TRENCH WIDTH FOR 60", 66" & 72" RCP NOT TO EXCEED OUTSIDE DIAMETER OF PIPE + 12" FROM BOTTOM OF TRENCH TO A POINT 2' ABOVE PIPE.
2. ALL LIFTING HOLES TO BE PLUGGED & MORTARED.
3. PVC PIPE – GRAVEL BEDDING/ENCASEMENT REQUIRED TO 3" ABOVE PIPE.
4. OTHER PIPE – GRAVEL BEDDING/ENCASEMENT PER DIRECTION OF ENGINEER.

SECTION NO. 1500	DRAWING NO. 5.1
REV.D. 2012	
<b>STORM SEWER TRENCH BACKFILL</b>	
CITY OF FARGO ENGINEERING DEPARTMENT	
APPROVED <i>BEO</i>	DATE <i>2-21-2012</i>

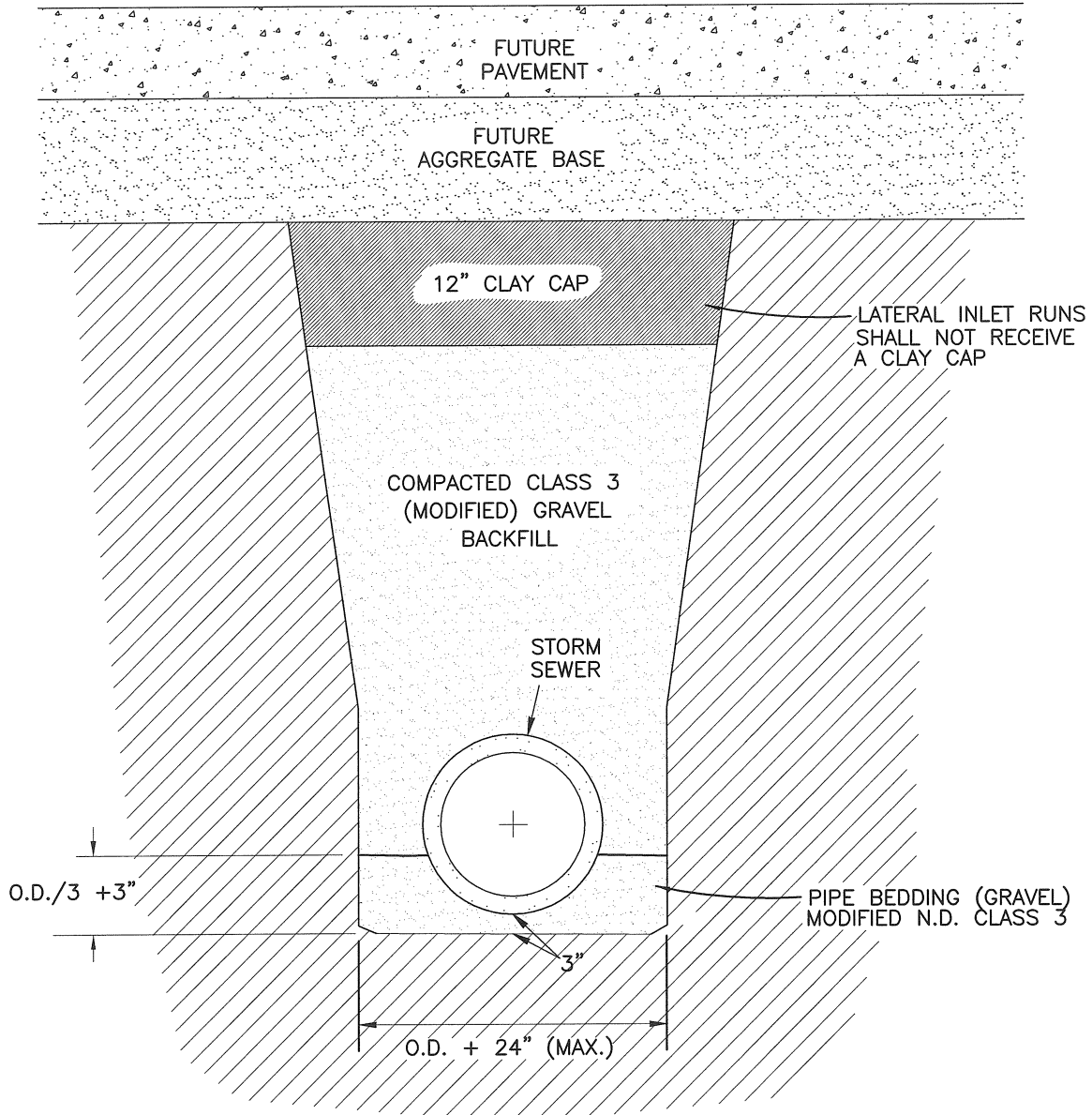

NOTES:

1. MAXIMUM TRENCH WIDTH FOR 60", 66" & 72" RCP NOT TO EXCEED OUTSIDE DIAMETER OF PIPE + 12" FROM BOTTOM OF TRENCH TO A POINT 2' ABOVE PIPE.
2. ALL LIFTING HOLES SHALL BE PLUGGED & MORTARED.
3. THIS DETAIL APPLIES WHERE STORM SEWER IS INSTALLED UNDER FUTURE PAVING WITH EDGE DRAIN.

SECTION NO.	1500	DRAWING NO.	5.2
REV.D.			
<b>STORM SEWER TRENCH UNDER NEW PAVEMENT</b>			
CITY OF FARGO ENGINEERING DEPARTMENT			
APPROVED	BED	DATE	2-21-2012



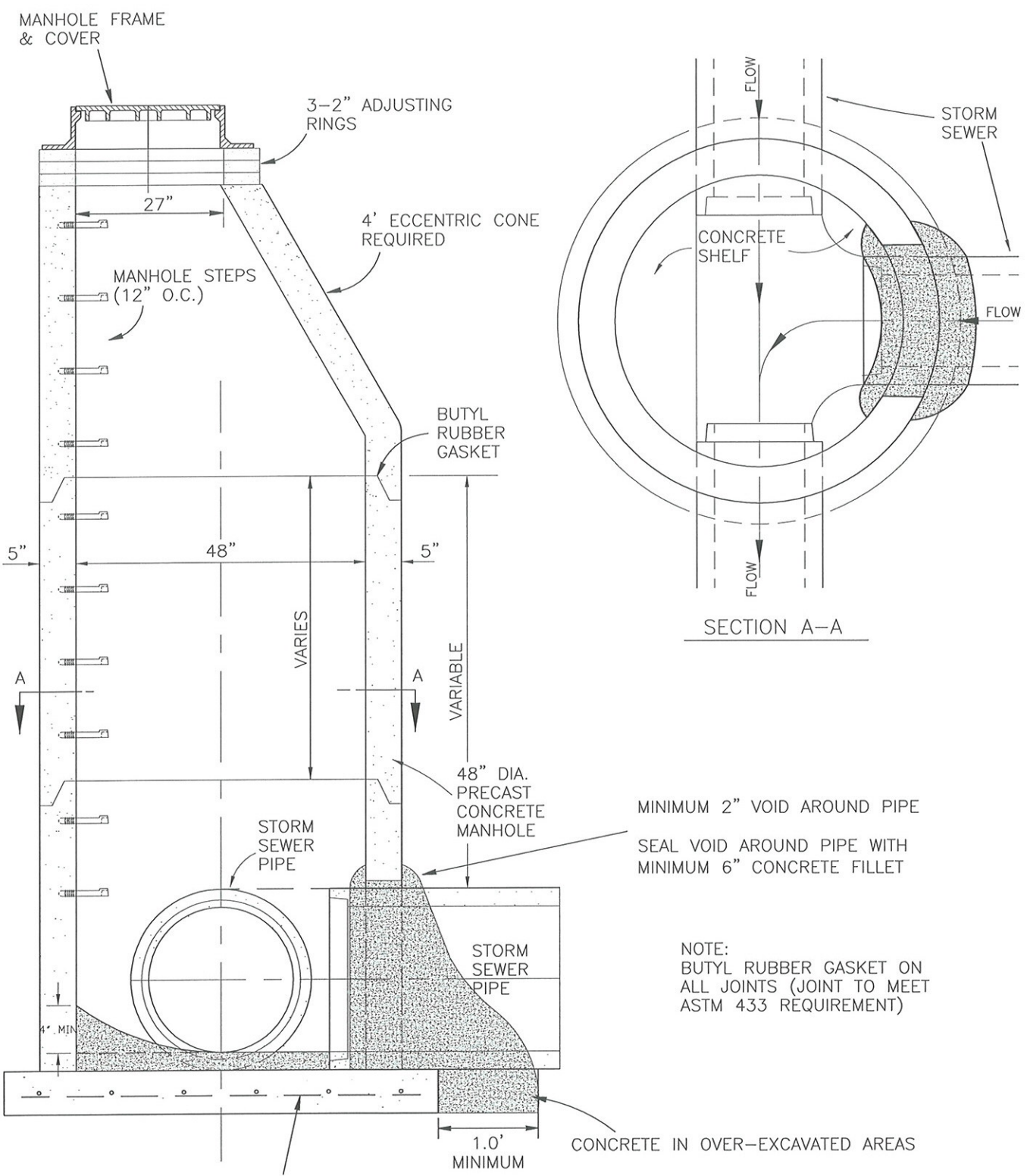

MINIMUM 2" VOID AROUND PIPE  
 SEAL VOID AROUND PIPE WITH  
 MINIMUM 6" CONCRETE FILLET

NOTE:  
 BUTYL RUBBER GASKET ON  
 ALL JOINTS (JOINT TO MEET  
 ASTM 433 REQUIREMENT)

5'4" DIA.x 6" REINFORCED CONC.  
 BASE SLAB (NO. 4 BARS 12" O.C.)

- NOTES:
1. CASTING FRAME AND COVER SHALL BE DETERMINED BY THE ENGINEER.
  2. MAXIMUM RCP DIA.-27" STRAIGHT THRU. MAXIMUM RCP DIA-18" AT RIGHT ANGLES.
  3. ALL JOINTS AND LIFTING HOLES SHALL BE MORTARED.

SECTION NO. 1500	DRAWING NO. 5.3
REV.D. 2013	
<b>STORM SEWER STANDARD MANHOLE</b>	
CITY OF FARGO ENGINEERING DEPARTMENT	
APPROVED <i>JME</i>	DATE 1-2-13

**NOTES:**

1. BUTYL RUBBER GASKET ON ALL JOINTS (JOINT TO MEET ASTM 433 REQUIREMENT)

2. CASTING FRAME AND COVER SHALL BE DETERMINED BY THE ENGINEER BASED ON STRUCTURE LOCATION & PURPOSE.

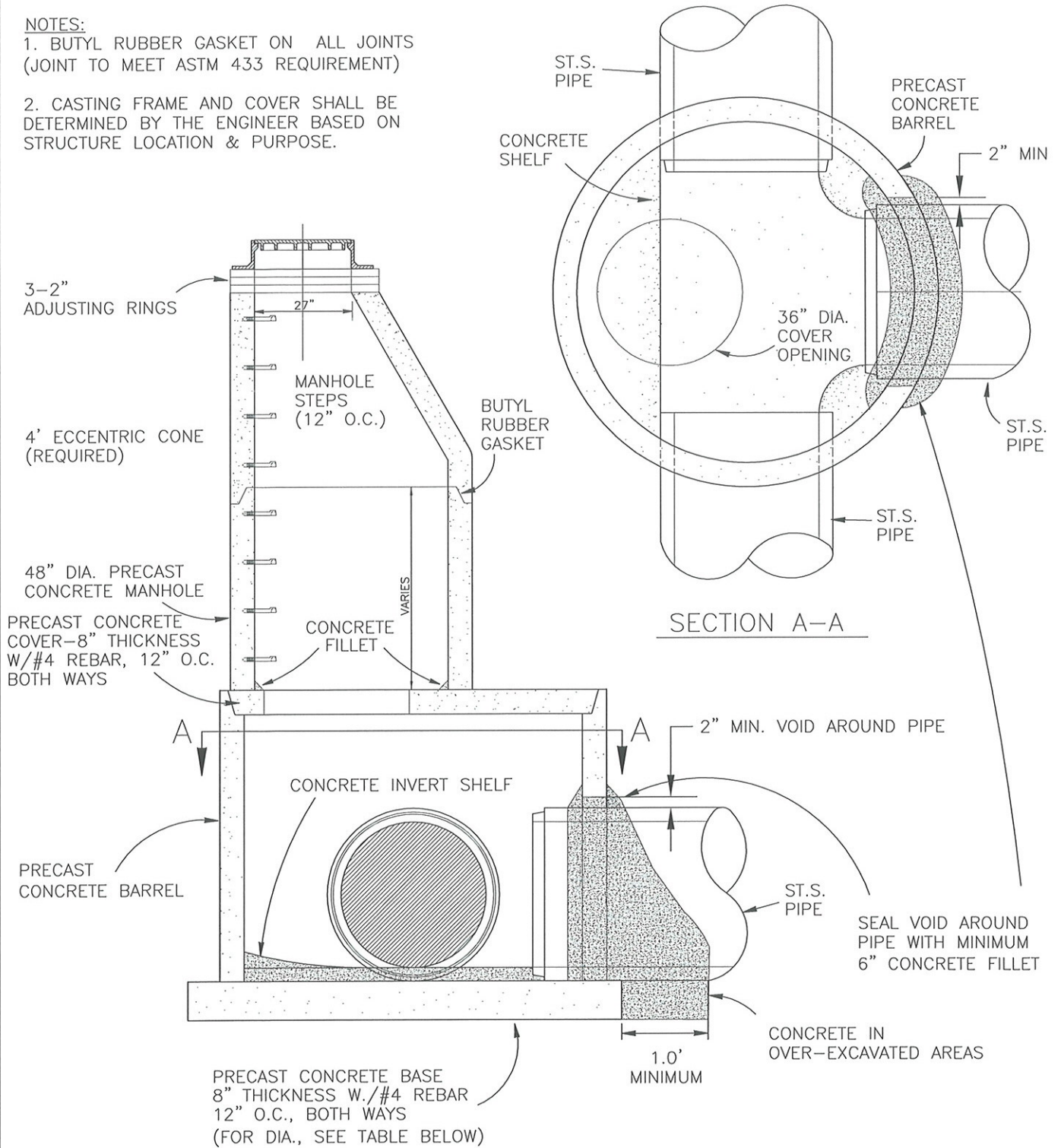

MANHOLE TYPE	(A) MANHOLE INSIDE DIA.	(B) MANHOLE OUTSIDE DIA.	MAXIMUM PIPE SIZES		
			0° ↘	90° ↘	135° ↘
A	60"	7'-0"	36"	24"	36"
B	72"	8'-0"	42"	33"	42"
C	84"	9'-4"	48"	36"	48"
D	96"	10'-6"	60"	42"	60"

SECTION NO. 1500	DRAWING NO. 5.4
REV.D. 2013	
<b>STORM SEWER MANHOLE TYPE "A - D"</b>	
CITY OF FARGO ENGINEERING DEPARTMENT	
APPROVED <i>CME</i>	DATE 1-2-13



**NOTES:**

1. CASTING FRAME AND COVER SHALL BE DETERMINED BY THE ENGINEER BASED ON STRUCTURE LOCATION & PURPOSE.

2. BUTYL RUBBER GASKET ON ALL JOINTS (JOINTS TO MEET ASTM 433 REQUIREMENT).

3. TYPE "E" MANHOLE SHALL BE BUILT TO THE DIMENSIONS SHOWN ON THE PLANS. THE WALLS SHALL BE REINFORCED WITH #4 REBAR 12" O.C.

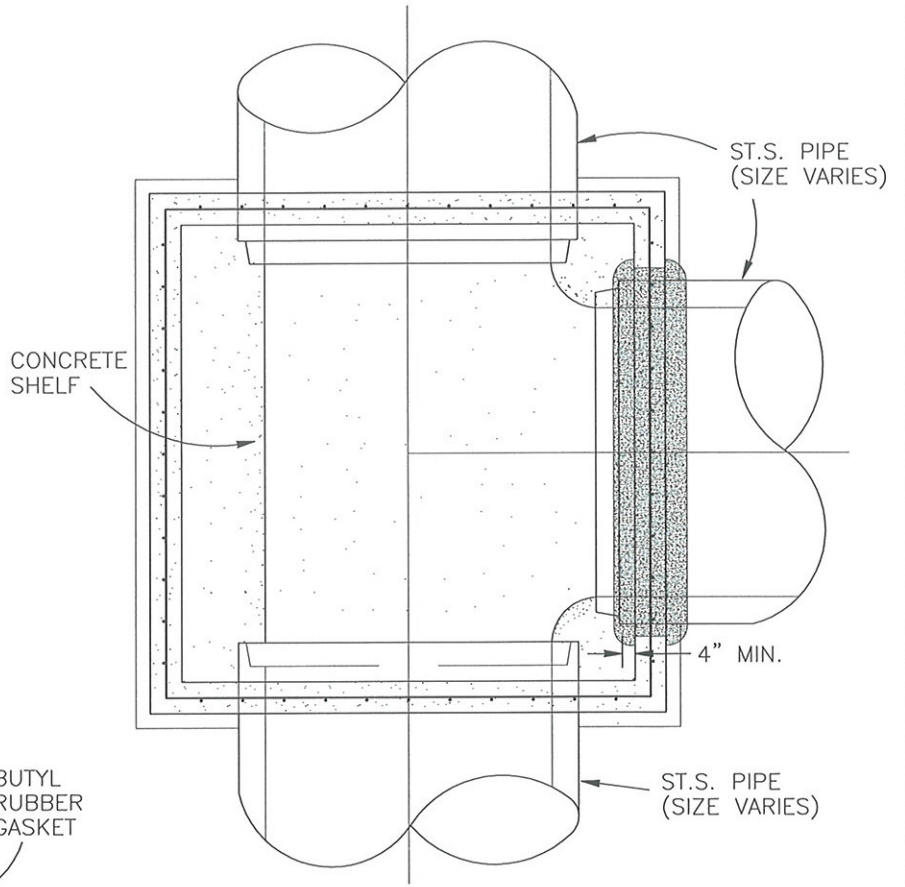

SECTION A-A

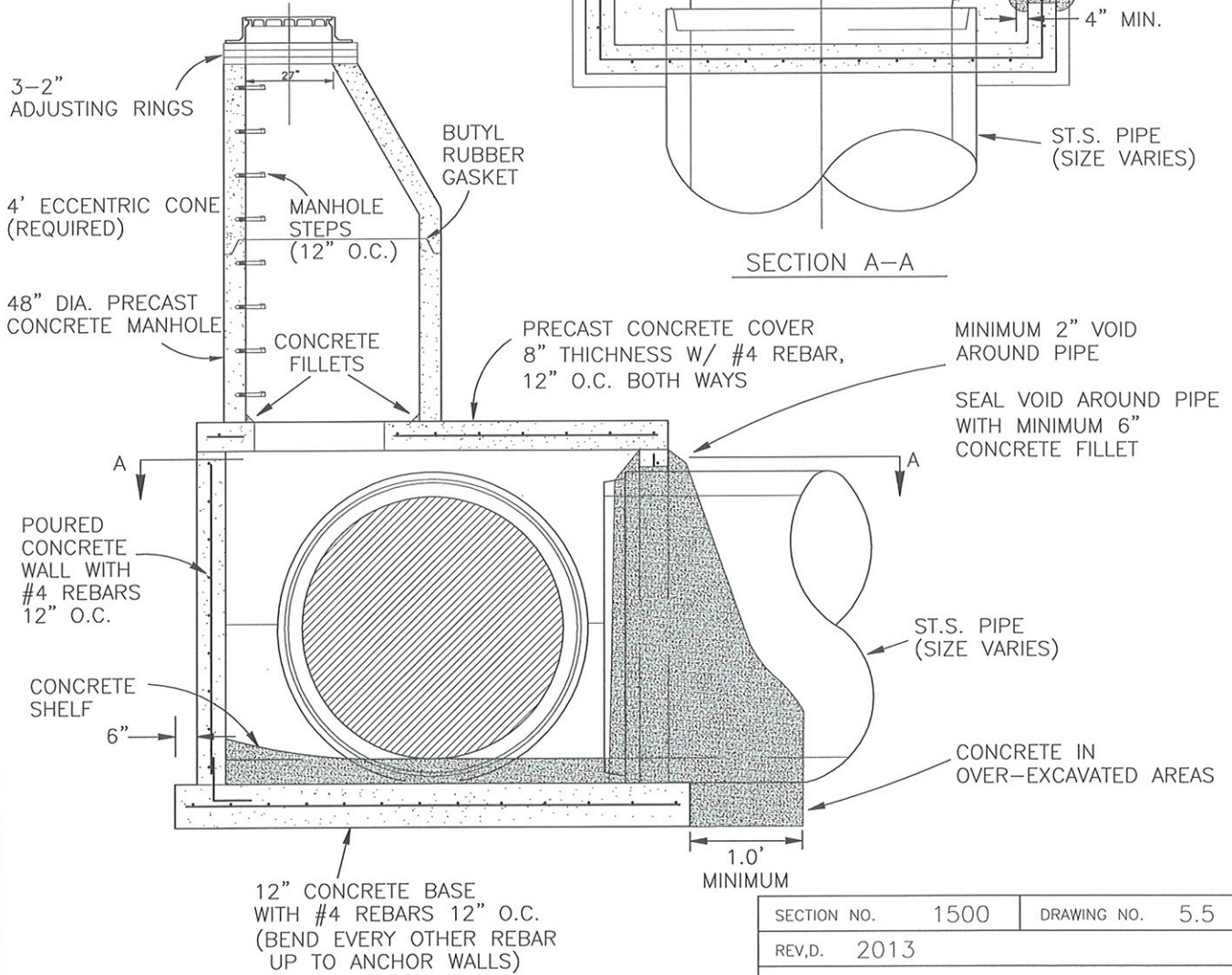

SECTION NO.	1500	DRAWING NO.	5.5
REV.D.	2013		
<b>STORM SEWER MANHOLE TYPE "E"</b>			
CITY OF FARGO ENGINEERING DEPARTMENT			
APPROVED	<i>ME</i>	DATE	1-2-13

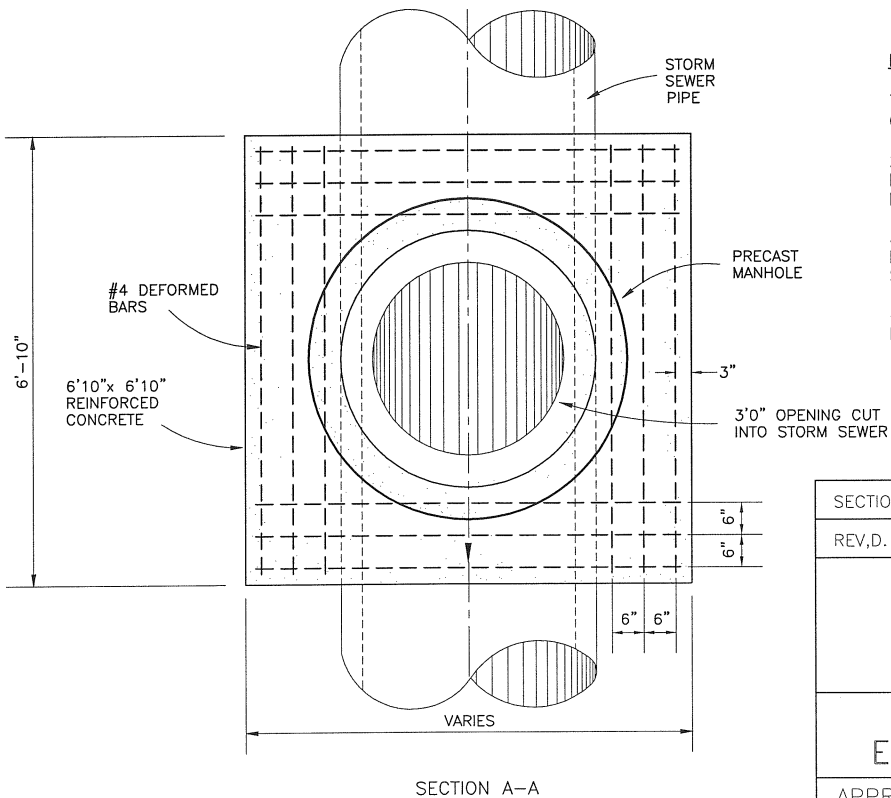
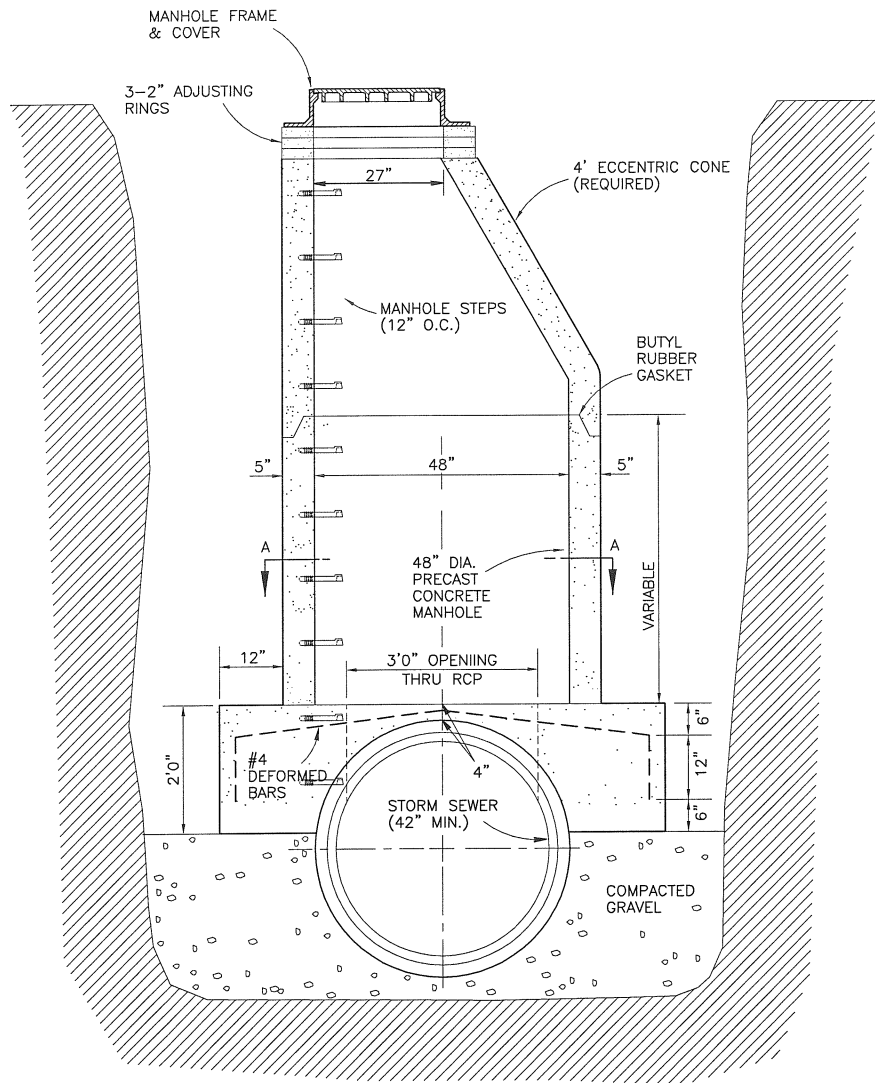

**NOTES:**

1. BUTYL RUBBER GASKET ON ALL JOINTS (JOINTS TO MEET ASTM 433 REQUIREMENT).
2. 3'0" OPENING THRU TOP OF R.C.P. SHALL BE GIVEN A SMOOTH MORTAR FINISH TO PERMIT ENTRY INTO STORM SEWER.
3. CASTING FRAME AND COVER SHALL DETERMINED BY THE ENGINEER BASED ON STRUCTURE LOCATION AND PURPOSE.
4. ALL JOINTS AND LIFTING HOLES SHALL BE MORTARED.

SECTION NO.	1500	DRAWING NO.	5.6
REV.D.	2012		
<b>STORM SEWER SADDLE MANHOLE</b>			
CITY OF FARGO ENGINEERING DEPARTMENT			
APPROVED	<i>BED</i>	DATE	<i>2-21-2012</i>

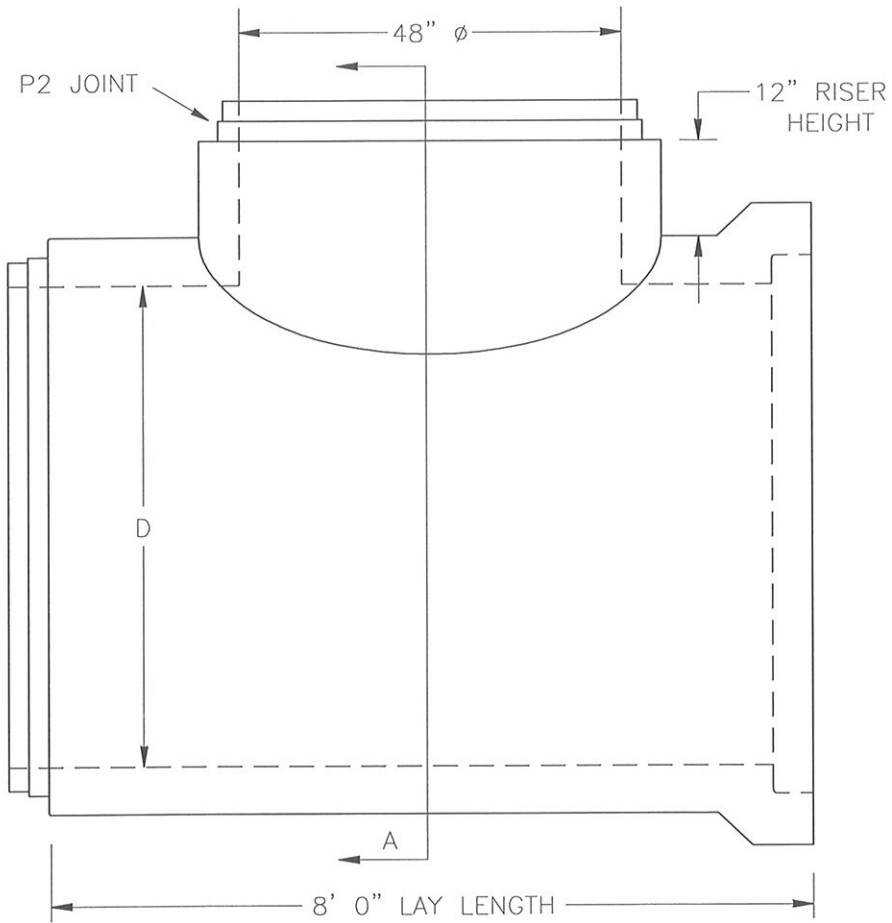

SIDE VIEW

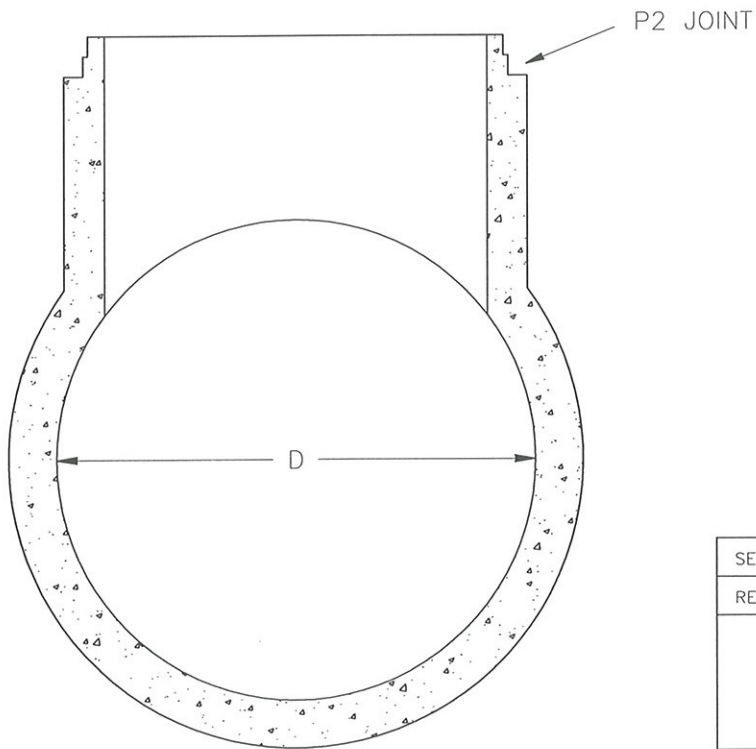

SECTION A-A

D
PIPE DIAMETER
48"
54"
60"
66"
72"
78"
84"
96"
102"
108"
120"

SECTION NO. 1500	DRAWING NO. 5.6B
REV.D.	
<i>INLINE TEE MANHOLE</i>	
CITY OF FARGO ENGINEERING DEPARTMENT	
APPROVED <i>JME</i>	DATE <i>1-2-13</i>

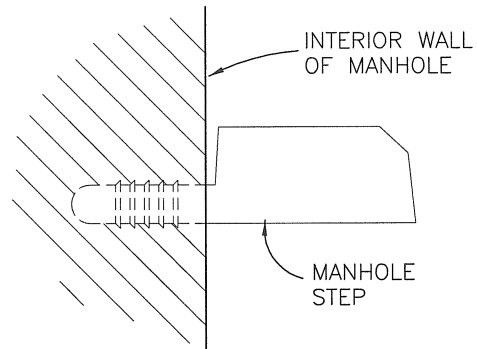
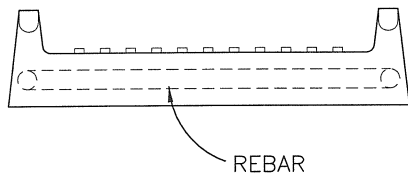
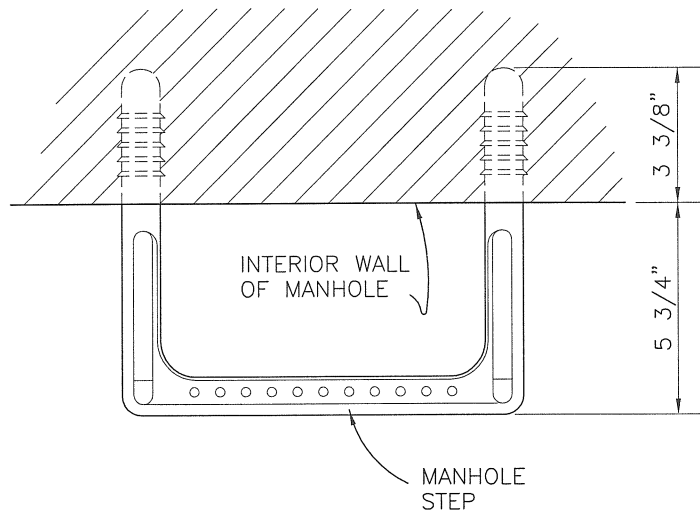

NOTE:  
 STEP SHALL BE CONSTRUCTED OF 1/2" REINFORCING ROD AND COMPLETELY ENCASED IN A CORROSION RESISTANT RUBBER OR POLYPROPYLENE PLASTIC, WHICH WILL RESIST DETERIORATION FROM HYDROGEN SULFIDE OR OTHER CHEMICALS AND GASES ENCOUNTERED IN MANHOLE APPLICATION.  
 ALSO, STEP SHALL HAVE A VERTICAL RESISTANCE OF 400 LBS., AND A PULLOUT RESISTANCE OF 1000 LBS. SUCH AS: THE WEDG-LOC STEP BY DELTA PIPE PRODUCTS OR APPROVED EQUAL.

SECTION NO.	1500	DRAWING NO.	5.7
REV.D.	March, 2000		
<b>MANHOLE STEP DETAIL</b>			
CITY OF FARGO ENGINEERING DEPARTMENT			
APPROVED	<i>BEO</i>	DATE	<i>2-21-2012</i>

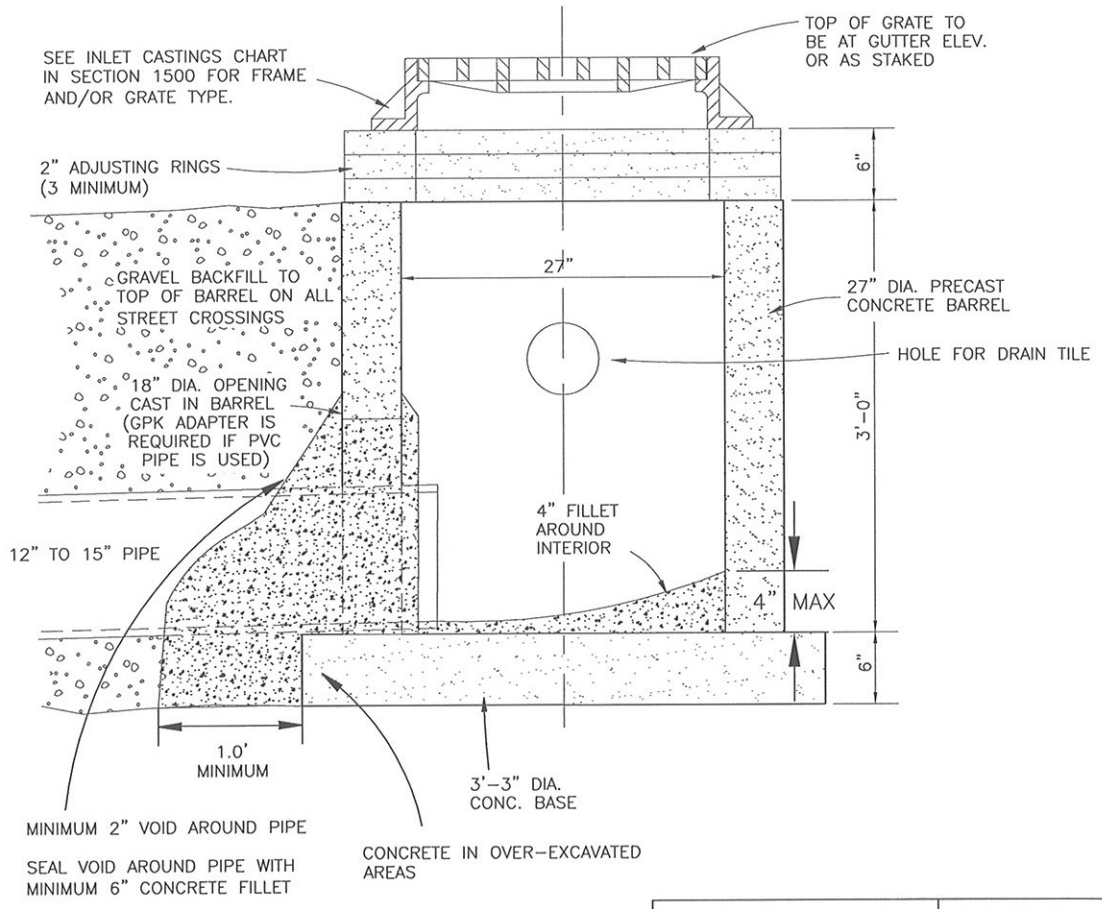
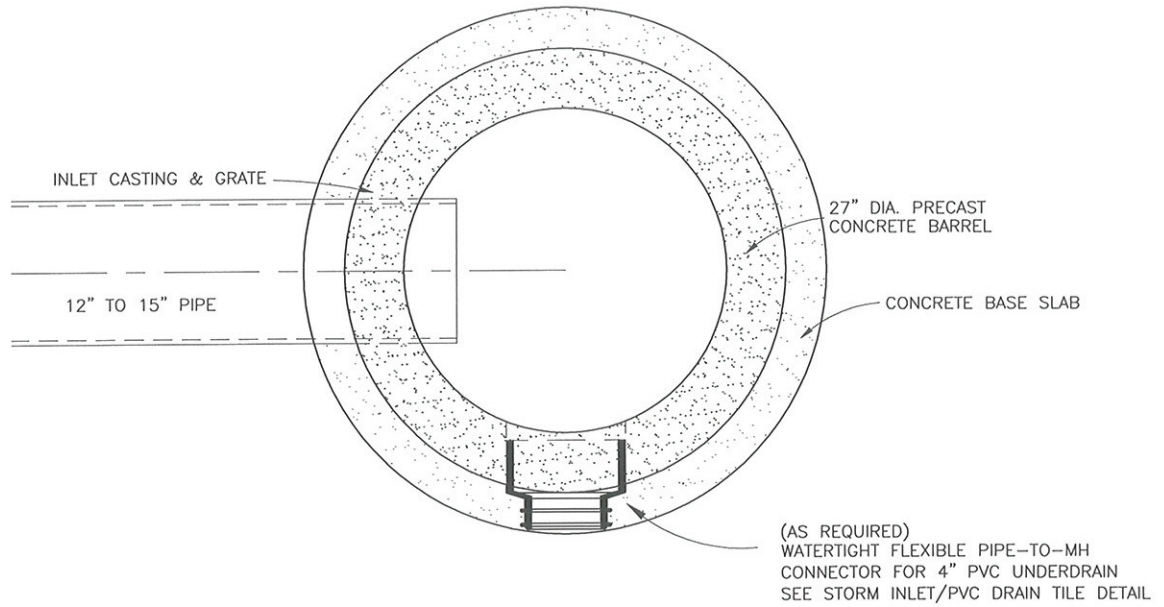

SECTION NO.	1500	DRAWING NO.	5.8
REV.D.	2013		
<b>STORM SEWER ROUND INLET (RDI)</b>			
CITY OF FARGO ENGINEERING DEPARTMENT			
APPROVED	<i>AME</i>	DATE	1-2-13



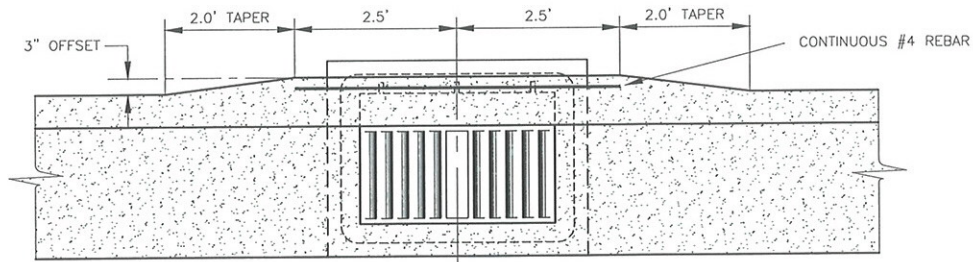
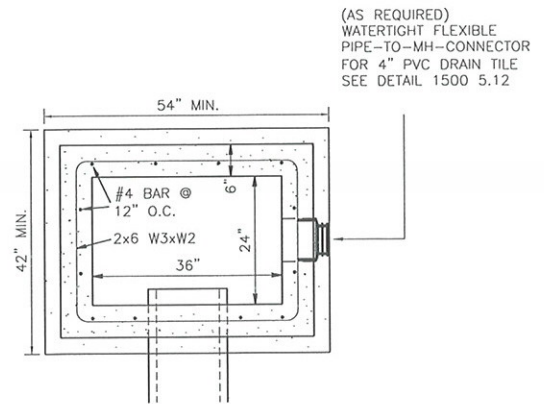
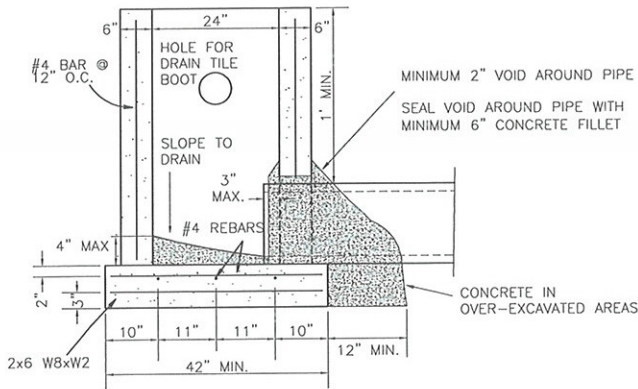

TYPE II CURB - PLAN VIEW

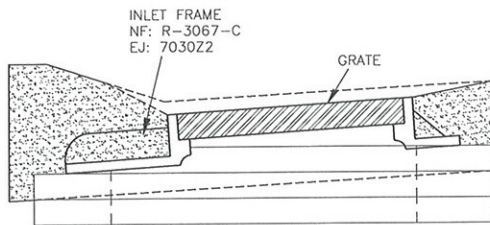

TYPE I CURB

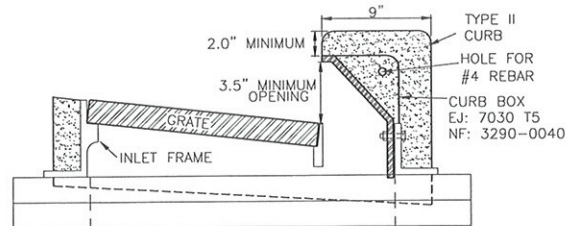

TYPE II CURB

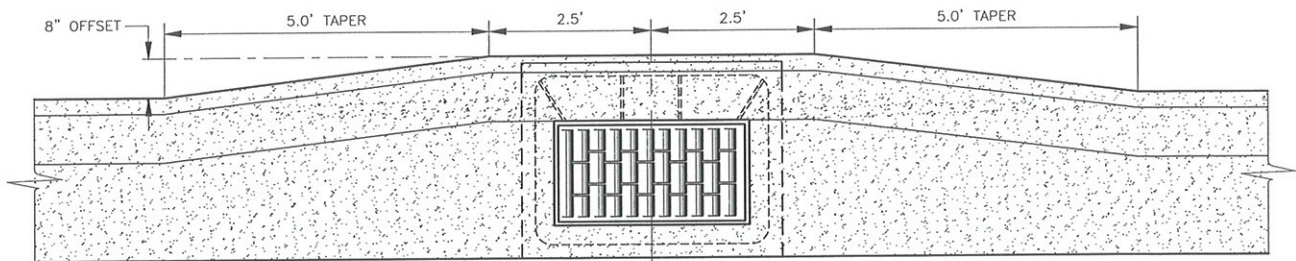

TYPE I CURB - PLAN VIEW

NOTES:

1. VERIFY FRAME, GRATE, & CURB BOX WITH INLET CASTINGS CHART IN SECTION 1500.
2. METAL USED IN THE MANUFACTURE OF CASTINGS SHALL CONFORM TO AASHTO M-105, CLASS 35B.
3. THE CONTRACTOR SHALL HAVE THE OPTION OF USING PRECAST OR POURED IN PLACE BASES. CLASS OF CONCRETE SHALL BE AE. THE AGGREGATE SIZE SHALL BE APPROVED BY THE ENGINEER IN THE FIELD.
4. PRECAST RISERS SHALL BE CONSTRUCTED IN ACCORDANCE WITH AASHTO M199.
5. ON PROJECTS WITH P.C.C. PAVEMENT ALL INLET RISERS OR BARRELS SHALL BE CONSTRUCTED 4 TO 5 INCHES BELOW FINAL ELEVATION AND ADJUSTED TO FINAL GRADE AFTER THE PAVING. ADJUSTMENT MAY BE DONE WITH ADJUSTMENT RINGS, MASONRY OR CAST-IN-PLACE. ALL COSTS FOR THIS ADJUSTMENT SHALL BE INCLUDED IN THE BID PRICE FOR THE INLET.

CURB BOX  
STANDARD CURB - NEENAH 3290-0040 or EAST JORDAN T5

SECTION NO. 1500	DRAWING NO. 5.9
REV.D. 2013	
<b>SINGLE BOX INLET (SBI) DETAIL</b>	
CITY OF FARGO ENGINEERING DEPARTMENT	
APPROVED <i>CME</i>	DATE 1-2-13



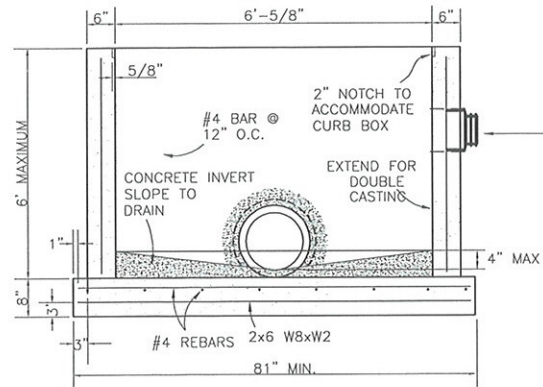
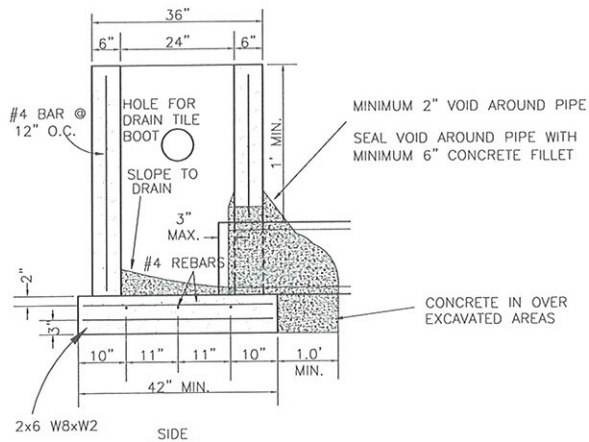

(AS REQUIRED)  
WATERTIGHT FLEXIBLE  
PIPE-TO-MH-CONNECTOR  
FOR 4" PVC DRAIN TILE  
SEE DETAIL 1500 5.12

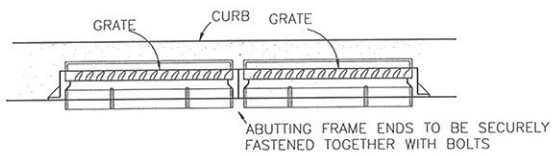

FRONT

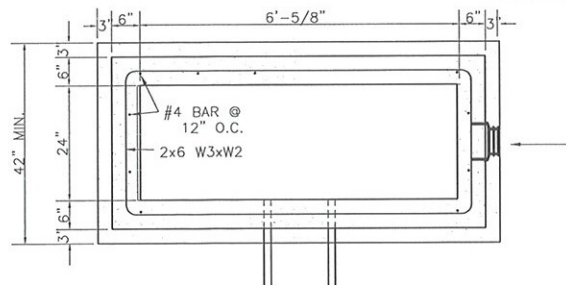

PLAN

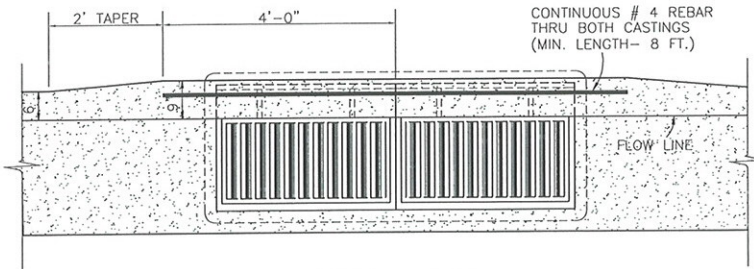

DOUBLE INLET PLAN  
TYPE II CURB

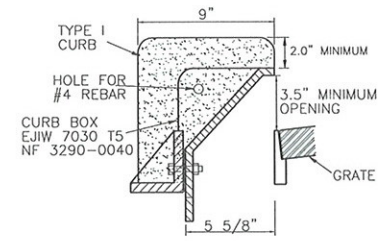

TYPE II CURB

**CURB BOX**  
STANDARD CURB - NEENAH 3290-0040 or E.J. T5  
MOUNTABLE CURB - NEENAH 3067-7009 or E.J. T7  
OR APPROVED EQUAL

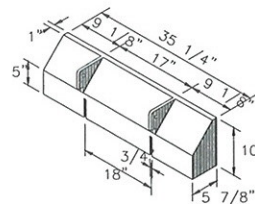

NOTES:

- SEE INLET CASTINGS CHART IN SECTION 1500 FOR FRAME AND/OR GRATE TYPE.
- METAL USED IN THE MANUFACTURE OF CASTINGS SHALL CONFORM TO AASHTO M-105, CLASS 35B.
- THE CONTRACTOR SHALL HAVE THE OPTION OF USING PRECAST OR POURED IN PLACE BASES. CLASS OF CONCRETE SHALL BE AE. THE AGGREGATE SIZE SHALL BE APPROVED BY THE ENGINEER IN THE FIELD.
- PRECAST RISERS SHALL BE CONSTRUCTED IN ACCORDANCE WITH AASHTO M199.
- ON PROJECTS WITH P.C.C. PAVEMENT ALL INLET RISERS OR BARRELS SHALL BE CONSTRUCTED 4 TO 5 INCHES BELOW FINAL ELEVATION AND ADJUSTED TO FINAL GRADE AFTER THE PAVING. ADJUSTMENT MAY BE DONE WITH ADJUSTMENT RINGS, MASONRY OR CAST-IN-PLACE. ALL COSTS FOR THIS ADJUSTMENT SHALL BE INCLUDED IN THE BID PRICE FOR THE INLET.

SECTION NO.	1500	DRAWING NO.	5.10
REV.D.	2013		
<b>DOUBLE BOX INLET (DBI) DETAIL</b>			
CITY OF FARGO ENGINEERING DEPARTMENT			
APPROVED	<i>CME</i>	DATE	1-2-13

CASTING FRAME AND COVER SHALL DETERMINED BY THE ENGINEER BASED ON STRUCTURE LOCATION AND PURPOSE.

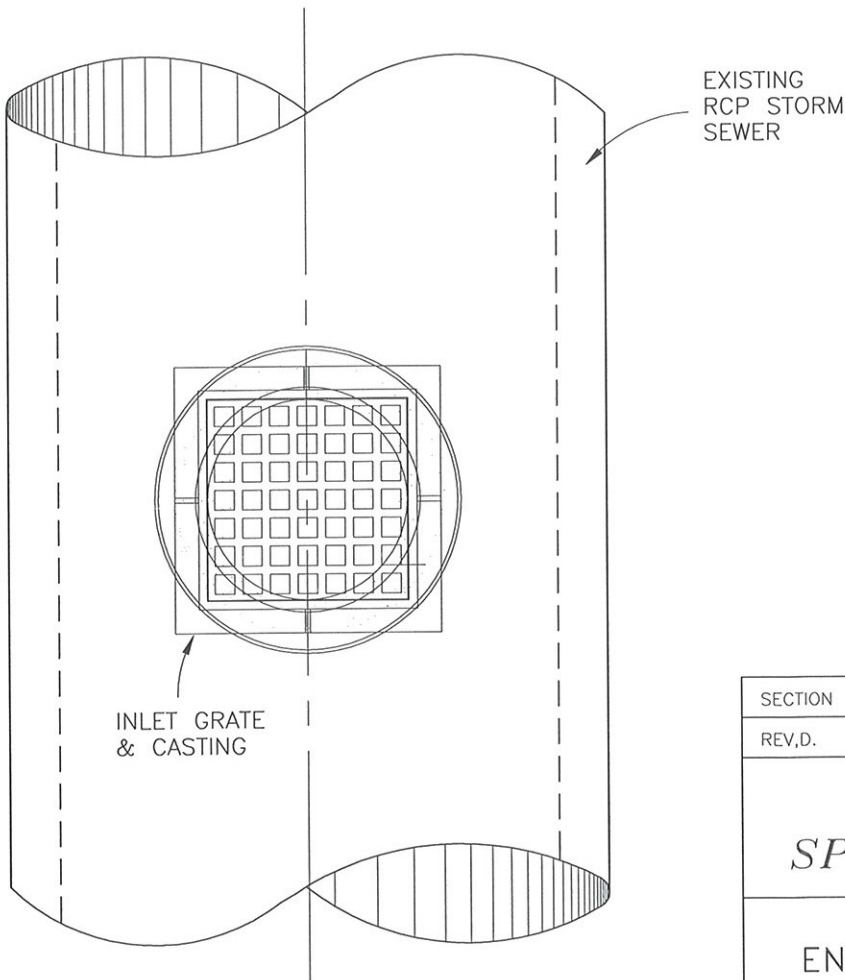
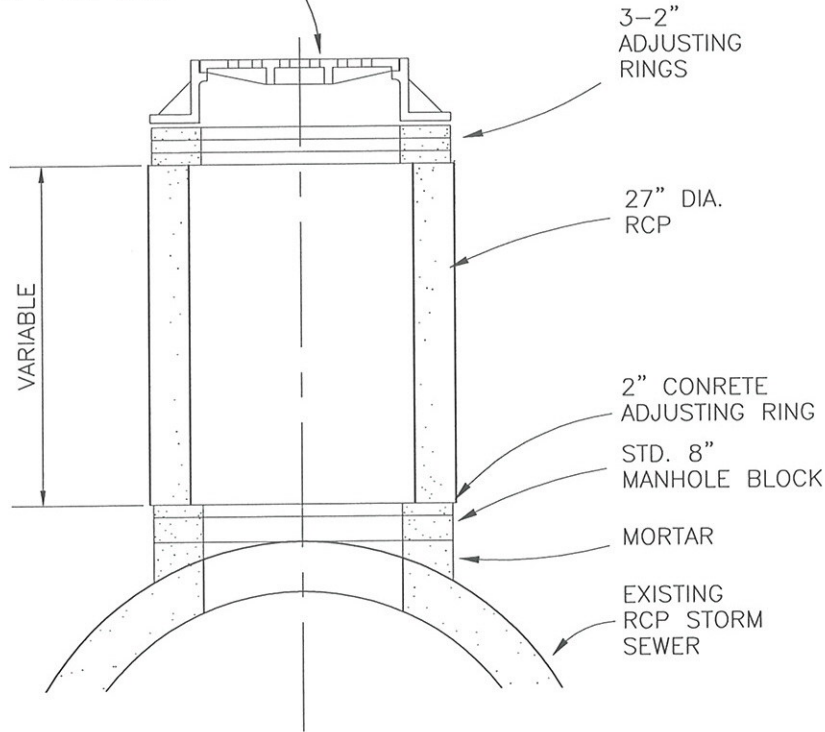

**NOTES:**

1. BUTYL RUBBER GASKET ON ALL JOINTS (JOINTS TO MEET ASTM 433 REQUIREMENT).
2. TOP OF INLET GRATE TO BE AT GUTTER ELEVATION OR 1.5' BELOW NATURAL GROUND IN NEW ADDITIONS.
3. 27" RCP BARREL TO BE A.S.T.M. DESIG. C76.
4. 27" OPENING THRU TOP OF R.C.P. SHALL BE GIVEN A SMOOTH MORTAR FINISH TO PERMIT SAFE ENTRY INTO STORM SEWER.
5. SPECIAL INLETS MAY ONLY BE INSTALLED ON 36" DIA. RCP OR LARGER PIPE.

SECTION NO.	1500	DRAWING NO.	5.11
REV.D.	2013		
<b>STORM SEWER SPECIAL INLET (SPI)</b>			
CITY OF FARGO ENGINEERING DEPARTMENT			
APPROVED	<i>OME</i>		DATE <i>1-2-13</i>

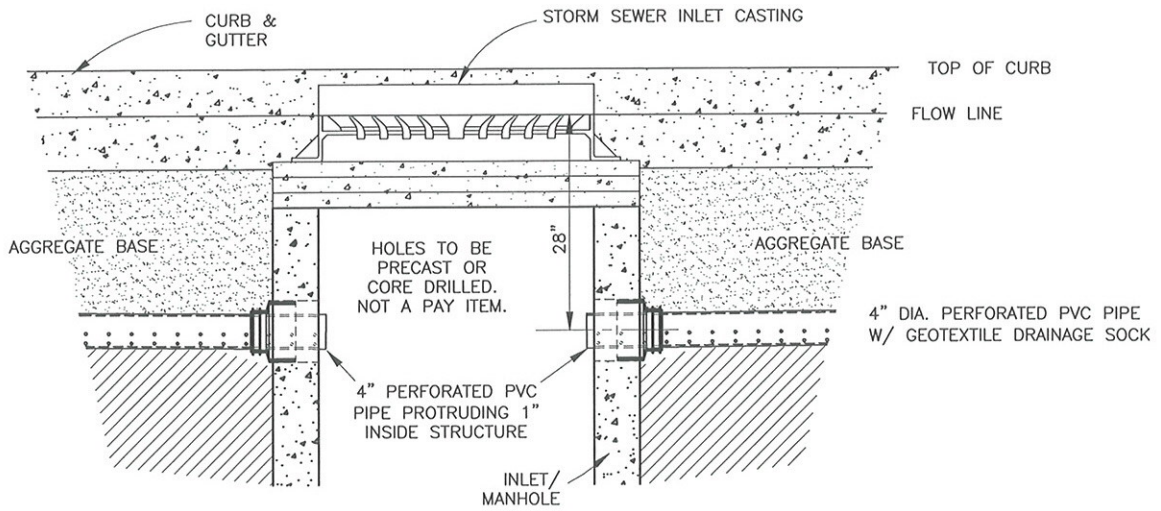

INLET/MANHOLE CONNECTION

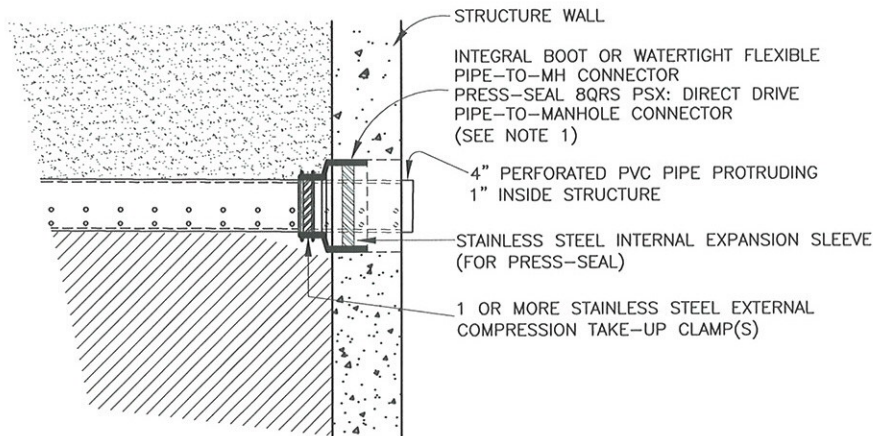

CONNECTION DETAIL

NOTES:

1. INSERTA TEE, LINK-SEAL, OR OTHER APPROVED EQUAL MAY BE UTILIZED WITH ENGINEER APPROVAL.
2. SEE 4" PVC EDGE DRAIN DETAIL IN SECTION 2100 FOR ADDITIONAL DETAILS.

SECTION NO. 1500	DRAWING NO. 5.12
REV.D. 2013	
<i>STORM INLET/PVC DRAIN PIPE DETAIL</i>	
CITY OF FARGO ENGINEERING DEPARTMENT	
APPROVED <i>CME</i>	DATE 1-2-13



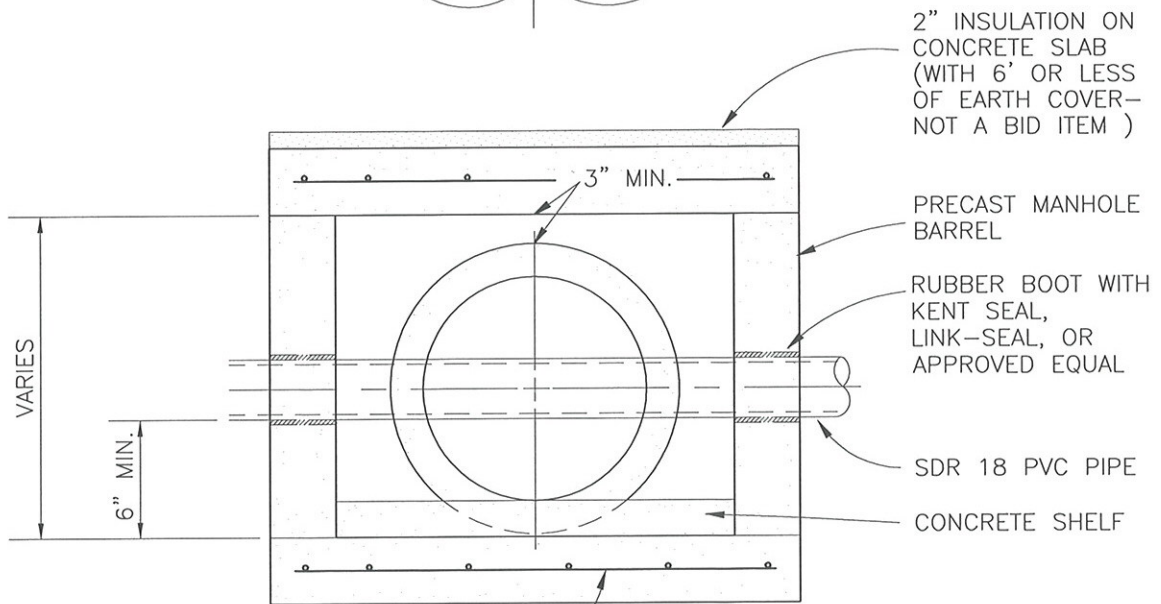
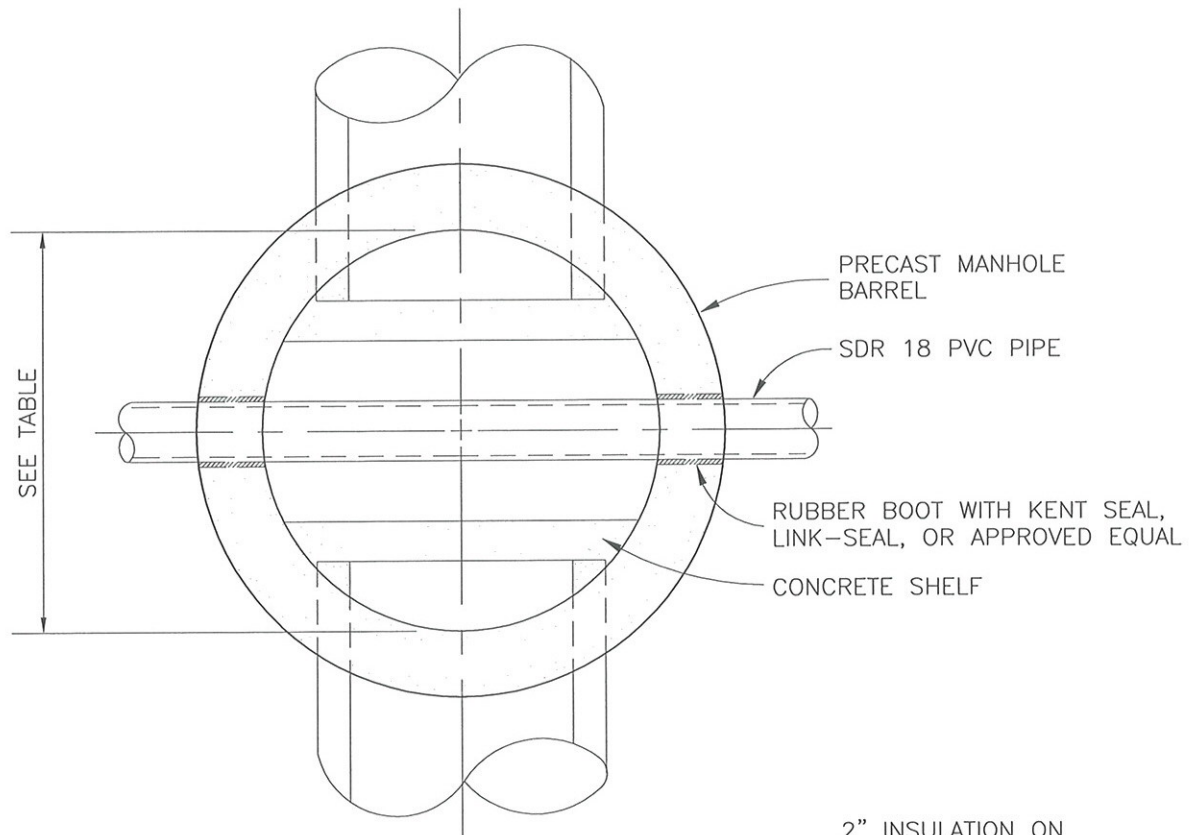

CONCRETE SLAB W/#4  
DEFORMED BARS 12" O.C.  
BOTH WAYS (TOP & BASE)  
(SEE TABLE FOR DIA. & THICKNESS)

RCP DIAMETER (MAXIMUM)	BASE (INSIDE DIA.)	BASE (THICKNESS)
15"	2'-0"	6"
27"	4'-0"	8"
54"	6'-0"	8"

SECTION NO. 1500	DRAWING NO. 5.13
REV.D. 2013	
<b>UTILITY CROSSING CHAMBER</b>	
CITY OF FARGO ENGINEERING DEPARTMENT	
APPROVED <i>CME</i>	DATE <i>1-2-13</i>

1- NO. 4 BAR (31" DIA.)  
FOR EACH MAT OF  
REINFORCING

3- RECESSED LIFT  
HOOKS AT 120°,  
18" FROM CENTER

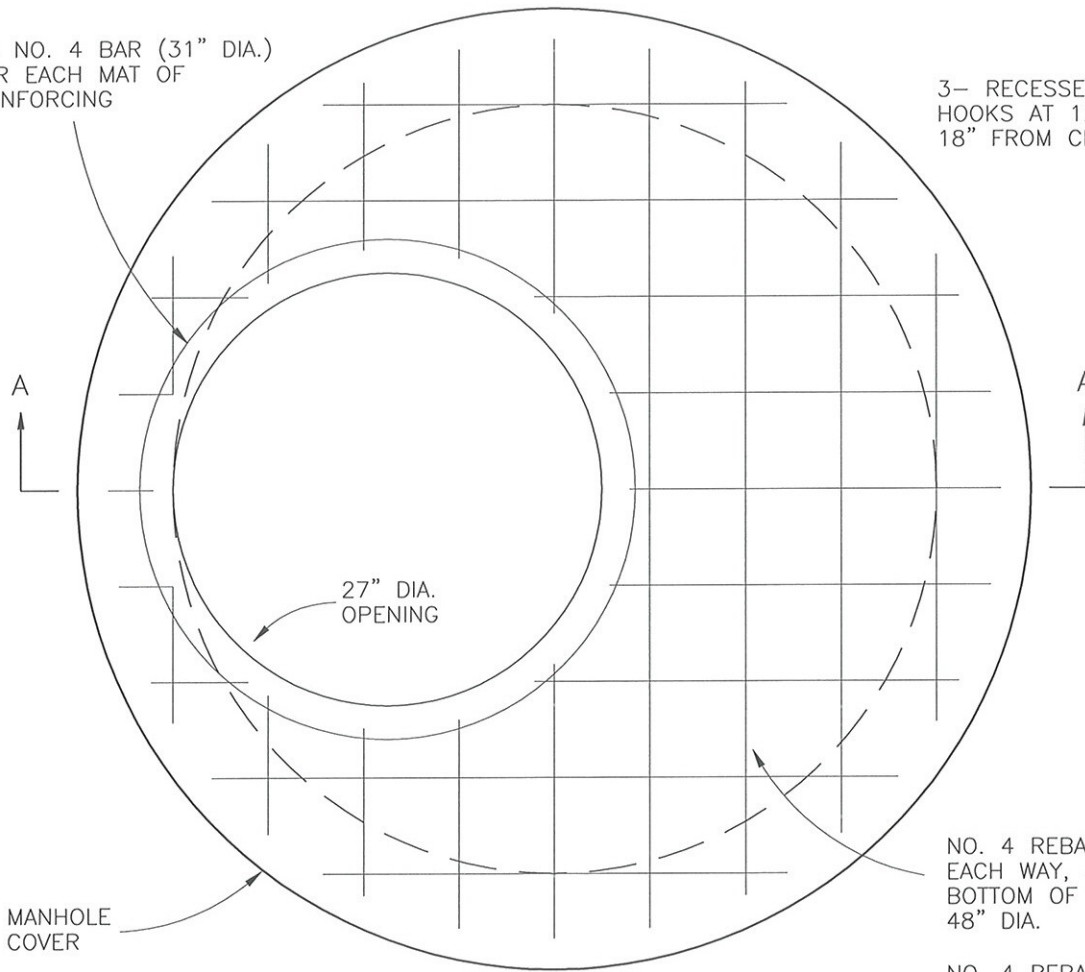

NO. 4 REBARS AT 6" O.C.  
EACH WAY, 3" UP FROM  
BOTTOM OF COVER FOR  
48" DIA.

NO. 4 REBARS AT 6" O.C.  
EACH WAY, 2" UP FROM  
BOTTOM OF COVER AND  
2" DOWN FROM TOP OF  
COVER FOR 60" DIA.  
DT

MANHOLE  
COVER

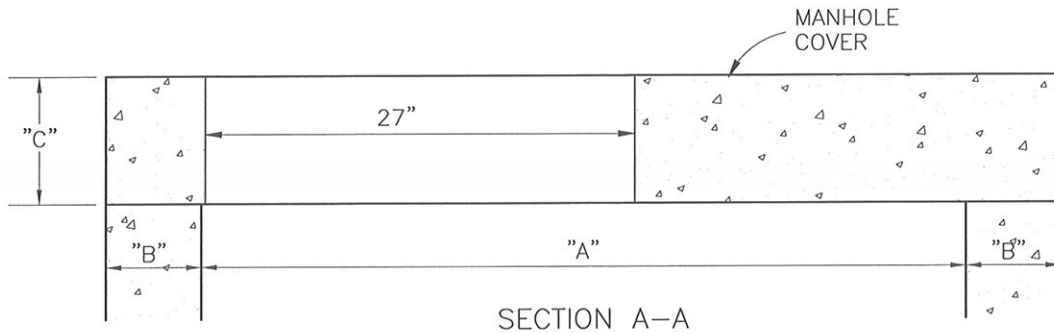

DIMENSION TABLE

A	B	C
48"	5"	6"
60"	6"	7"
72"	7"	8"
84"	8"	9"
96"	9"	9"

TO BE USED WHEN  
STRUCTURE IS LOCATED  
OUTSIDE GUTTER LINE

SECTION NO. 1500	DRAWING NO. 5.14
REV.D. January 2013	
<b>MANHOLE COVER DETAIL</b>	
CITY OF FARGO ENGINEERING DEPARTMENT	
APPROVED <i>CME</i>	DATE 1-2-13

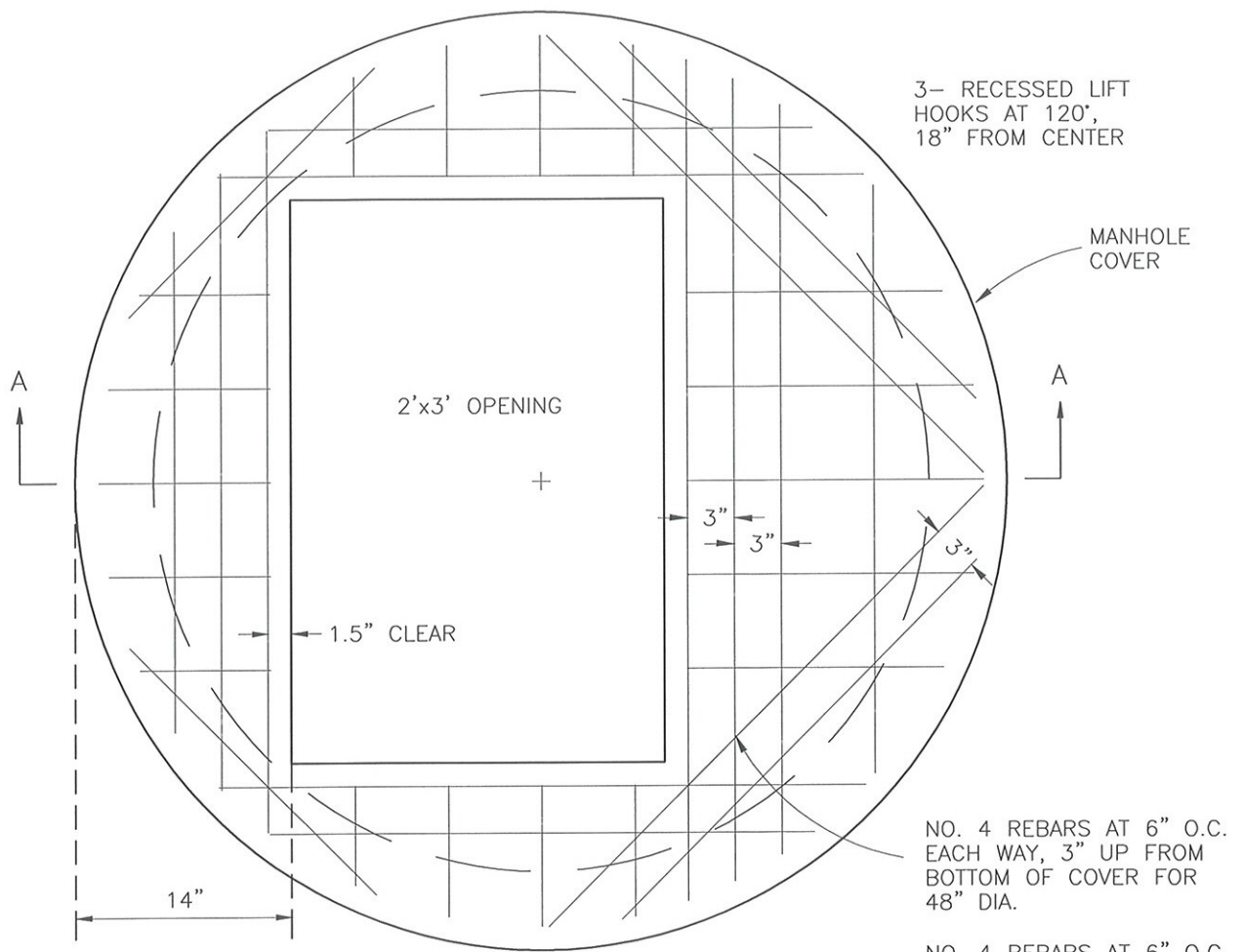

NO. 4 REBARS AT 6" O.C. EACH WAY, 3" UP FROM BOTTOM OF COVER FOR 48" DIA.

NO. 4 REBARS AT 6" O.C. EACH WAY, 2" UP FROM BOTTOM OF COVER AND 2" DOWN FROM TOP OF COVER FOR 60" DIA.

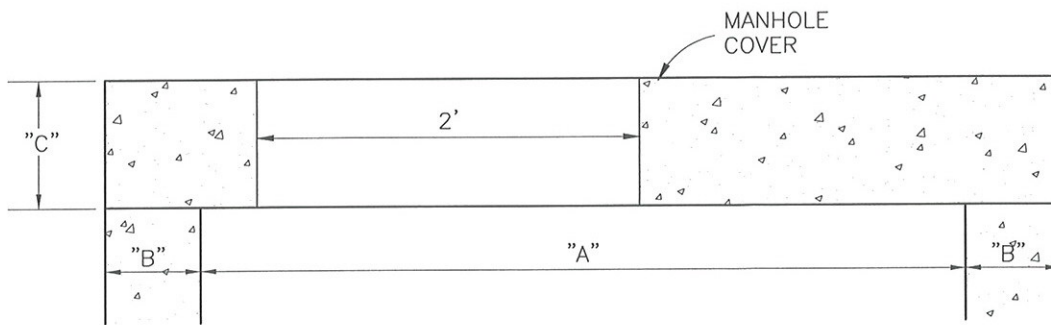

SECTION A-A

DIMENSION TABLE

A	B	C
48"	5"	6"
60"	6"	7"
72"	7"	8"
84"	8"	9"
96"	9"	9"

TO BE USED WHEN STRUCTURE IS LOCATED IN GUTTER LINE

SECTION NO. 1500	DRAWING NO. 5.14B
REV.D.	
<b>MANHOLE COVER DETAIL (GUTTER)</b>	
CITY OF FARGO ENGINEERING DEPARTMENT	
APPROVED <i>CME</i>	DATE 1-2-13

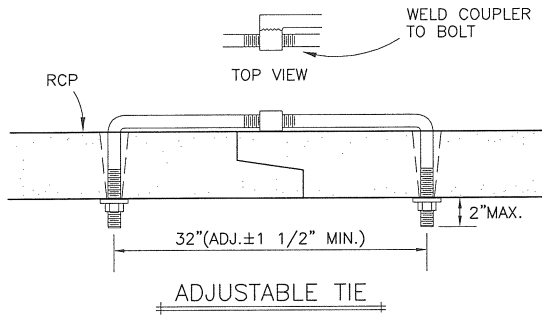

REQUIRED SIZE OF TIE BOLTS					
PIPE SIZE (INCHES)	THREAD DIA.	PIPE SIZE (INCHES)	THREAD DIA.	PIPE SIZE (INCHES)	THREAD DIA.
12	5/8"	30	3/4"	72	1"
15		33		78	
18		36		84	
21		42		90	
24		48		96	
27	SEE NOTE TWO	54		102	
		60		108	
		66		120	
				132	

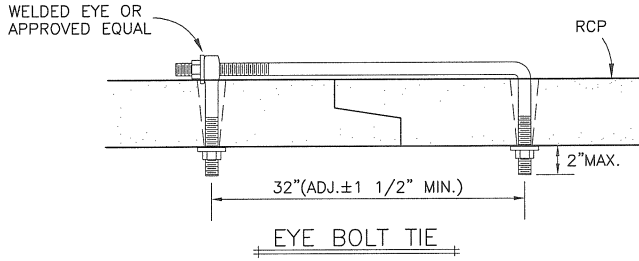

THREAD DIA.	E.S. PIPE DIA
5/8"	3/4"
3/4"	1"
1"	1 1/4"

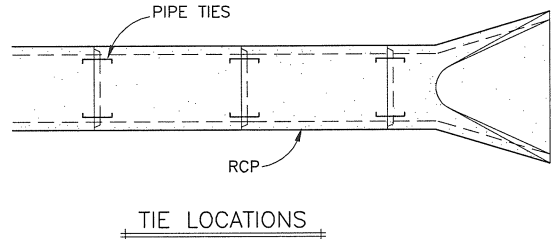
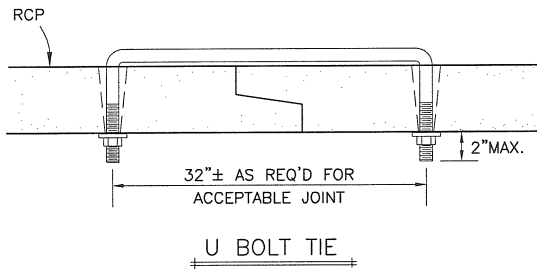
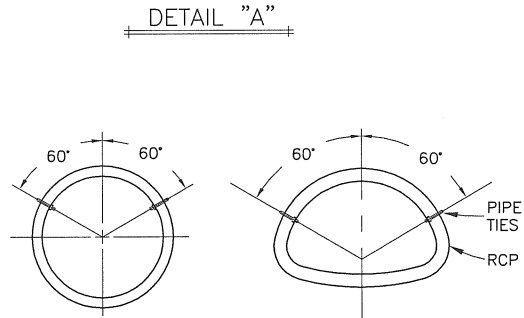
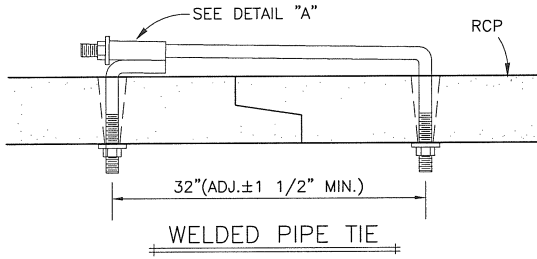
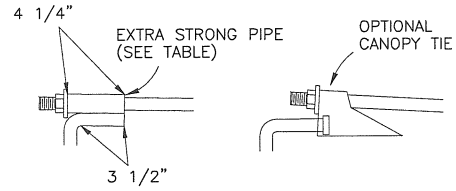

NOTES

- PIPE SIZE LISTED IS INSIDE DIAMETER OF ROUND PIPE OR EQUIVALENT DIAMETER OF PIPE ARCH.
- NUTS AND WASHERS ARE NOT REQUIRED ON INSIDE OF 21" DIAMETER PIPE OR LESS.
- TIES TO BE USED ONLY TO HOLD PIPE SECTIONS TOGETHER, NOT FOR PULLING SECTIONS TIGHT.
- TIE BOLTS SHALL BE PAINTED AFTER FABRICATION WITH ONE COAT OF ZINC CHROMATE IRON OXIDE PAINT. THREADED PORTION OF RODS DO NOT HAVE TO BE PAINTED.
- HOLES IN PIPE TO ACCOMMODATE THE TIE BOLTS CAN BE PRECAST OR DRILLED. TAPERED HOLES WILL BE PERMITTED WHEN PRECAST. WHEN EXISTING PIPE ARE EXTENDED OR SALVAGED AND RELAYED, THE CONTRACTOR WILL BE REQUIRED TO DRILL THE NECESSARY HOLES.
- THE CONTRACTOR HAS THE OPTION OF SELECTING THE TYPE OF TIE BOLT TO BE USED. THE TYPE SELECTED SHALL BE APPROVED BY THE ENGINEER.
- THE COST OF PRECASTING OR DRILLING THE REQUIRED HOLES AND FURNISHING AND INSTALLING THE TIE BOLTS SHALL BE INCLUDED IN THE PRICE BID FOR REINFORCED CONCRETE PIPE CULVERTS.
- TIE BOLTS ARE NOT REQUIRED ON STORM SEWER PIPE UNLESS SPECIFICALLY NOTED IN THE PLANS.
- TIE BOLTS ARE REQUIRED ON END SECTIONS (4 SECTIONS) FOR ALL R.C.P. CULVERTS. ON CULVERTS WITHOUT FLARED END SECTIONS, THE THREE END SECTIONS OF THE CULVERT SHALL BE TIED TOGETHER IN THE SAME MANNER FOR EACH END.

SECTION NO. 1500	DRAWING NO. 5.15
REV.D. March, 1999	
<b>CONCRETE PIPE TIES DETAILS</b>	
CITY OF FARGO ENGINEERING DEPARTMENT	
APPROVED <i>BED</i>	DATE <i>2-21-2012</i>

ALL TRASH GUARDS TO HAVE (1) CROSS BAR  
60" DIA. & UP TO HAVE (2) BARS EQUALLY  
SPACED

HOT DIP GALVANIZED PER MN/DOT 3392  
OR ASTM-A153

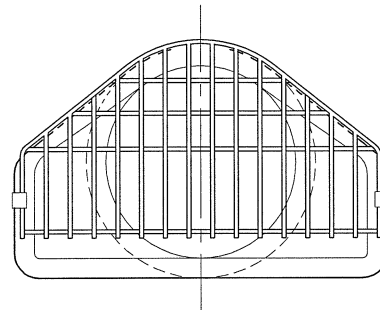
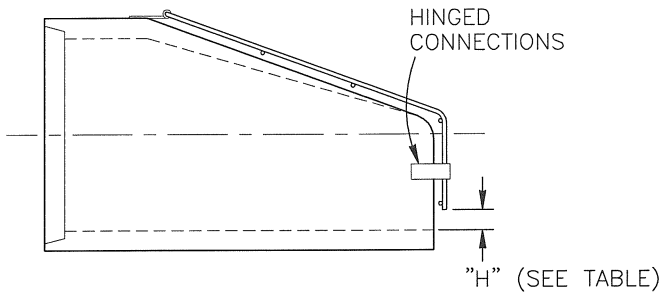
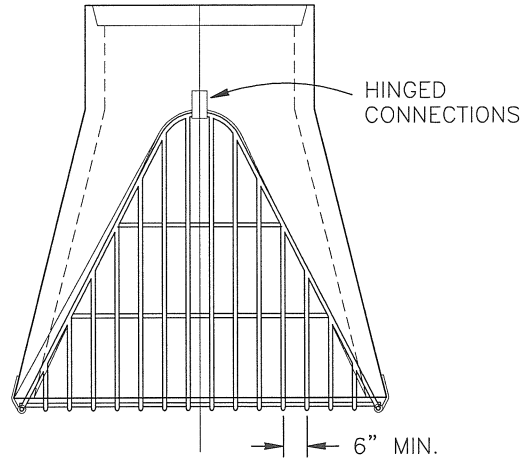

BAR SIZES									
STANDARD DESIGN					HEAVY DESIGN				
	PIPE SIZE	HOLE DIA. REQ'D	BOLT DIA.	BAR SIZE		PIPE SIZE	HOLE DIA. REQ'D	BOLT DIA.	BAR SIZE
ROUND	12"-24"	3/4"	5/8"	5/8"	ROUND	12"-18"	3/4"	5/8"	3/4"
	27"-48"	7/8"	3/4"	3/4"		21"-42"	7/8"	3/4"	1"
	54"-90"	1 1/8"	1"	1"		48"-90"	1 1/8"	1"	1 1/4"
ARCH	22"-29"	3/4"	5/8"	5/8"	ARCH	22"	3/4"	5/8"	3/4"
	36"-59"	7/8"	3/4"	3/4"		29"-51"	7/8"	3/4"	1"
	65"-88"	1 1/8"	1"	1"		59"-88"	1 1/8"	1"	1 1/4"

BOLT LG. = PIPEWALL THICKNESS + 2 1/2"

VALUES FOR "H"			
ROUND PIPE		ARCH PIPE	
PIPE SIZE	H	PIPE SIZE	H
12"	2 1/2"	22"-29"	4"
15"	3"	36"-44"	5"
18"-24"	4"	51"-55"	6"
27"-36"	5"	73"-88"	7"
42"-54"	6"		
60"-72"	7"		
78"-90"	8"		

SECTION NO. 1500	DRAWING NO. 5.16
REV.D. March, 1999	
<b>TRASH GUARD FOR FLARED END SECTIONS</b>	
CITY OF FARGO ENGINEERING DEPARTMENT	
APPROVED <i>BEO</i>	DATE <i>2-21-2012</i>



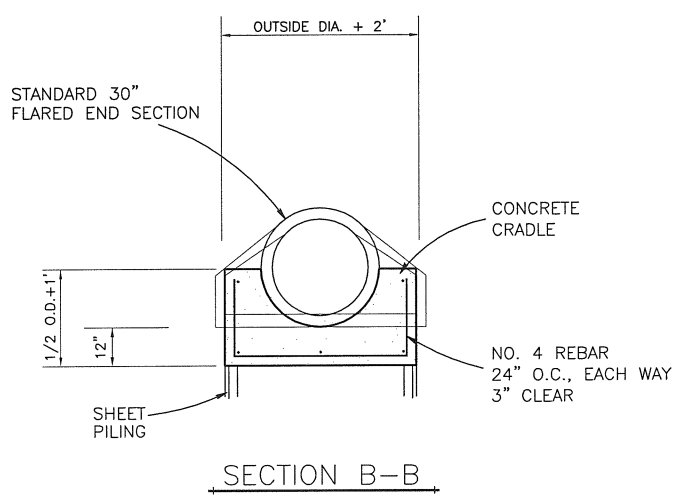
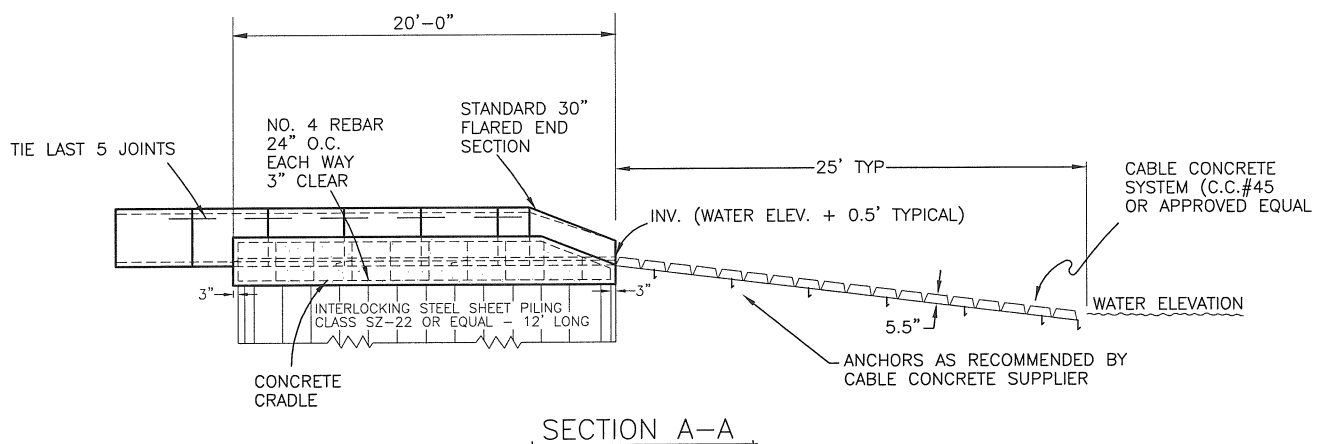
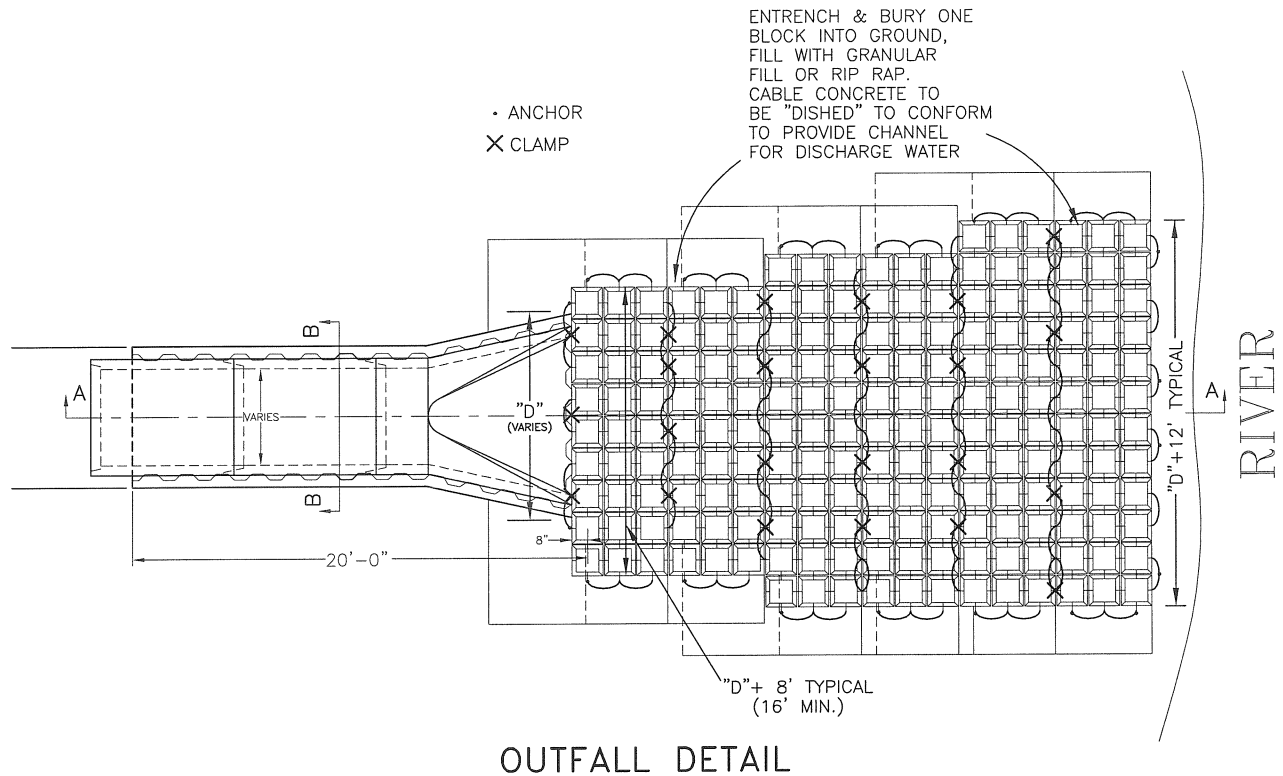

SECTION NO. 1500	DRAWING NO. 5.17
REV.D. MARCH, 2007	
<b>OUTFALL DETAIL</b>	
CITY OF FARGO ENGINEERING DEPARTMENT	
APPROVED <i>BEO</i>	DATE <i>2-21-2012</i>

Reinforcing:

- 5 – No. 4 Deformed Bars (Circumferential)
- No. 4 Deformed Bars 12" O.C. (Transverse across joint)

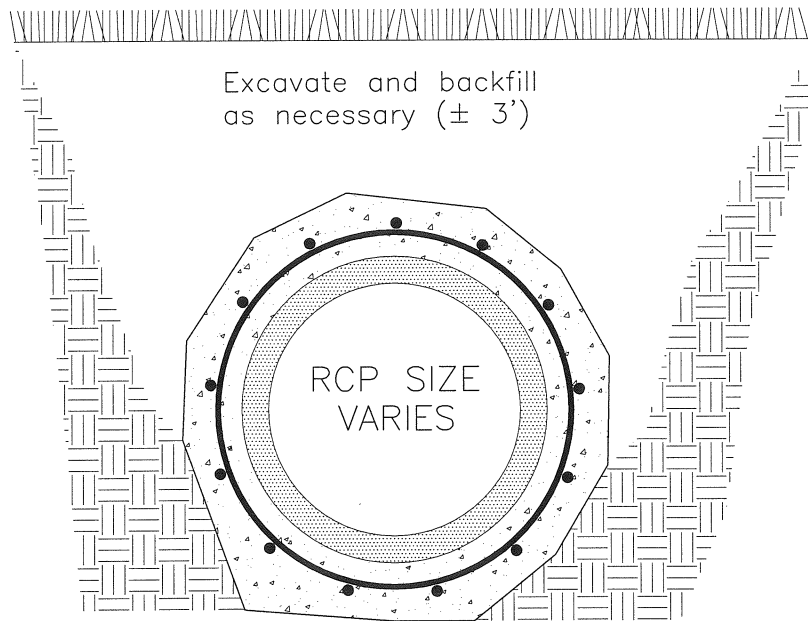

8" Minimum Concrete Repair Band.  
Extend 18" Along Pipe Each  
Direction from Joint.

SECTION NO. 1500	DRAWING NO. 5.18
REV.D. 2012	
<i>PIPE JOINT REPAIR BAND DETAIL</i>	
CITY OF FARGO ENGINEERING DEPARTMENT	
APPROVED <i>BED</i>	DATE <i>2-21-2012</i>

**CITY OF FARGO SPECIFICATIONS  
PIPE AND MANHOLE REHABILITATION**

**PART 1  
DESCRIPTION OF WORK**

The work to be done under this section of the Specifications and the accompanying plans shall include all labor, materials, and equipment necessary to provide for the reconstruction or rehabilitation of pipes and manholes.

The rehabilitation of the sanitary manholes shall be by means of a restorative liner specifically designed for sanitary sewer manholes.

When flow through the sewer cannot be maintained during the course of the work, sewer flows shall be bypassed in accordance with Section 1200 of these Specifications.

**PART 2**  
**MATERIAL**

2.1. CURED IN PLACE SEWER PIPE (CIPP)

A resin impregnated flexible tube is inverted into the existing pipe utilizing a hydrostatic head, air pressure, or other approved method. The tube shall then be cured to form a hard impermeable pipe. When cured, the liner shall extend over the designated length of the existing pipe in a continuous tight fitting watertight pipe-within-a-pipe. The CIPP shall be fabricated from materials which, when cured, shall be chemically resistant to withstand internal exposure to the type of fluid to be carried by the pipe.

*2.1.1. TUBE*

The tube shall meet the requirements of ASTM F216 Section 5.1 and should consist of one or more layers of flexible needled felt or an equivalent nonwoven or woven material, capable of carrying resin, withstanding installation pressures and curing temperatures. The tube shall be compatible with the resin system used. The material shall be able to stretch to fit irregular pipe sections and negotiate bends. The outside layer of the tube shall be plastic coated with a material that is compatible with the resin system used. The tube shall be fabricated to a size that, when installed, will tightly fit the internal circumference and length of the original conduit. Allowance shall be made for circumferential stretching during the installation process.

*2.1.2. RESIN*

The resin shall be a general purpose, unsaturated, styrene based, thermoset resin and catalyst system or an epoxy resin and hardener that is compatible with the inversion process being used. The Resin shall meet the requirements of ASTM F1216 and the following requirements. The resin must be able to cure in the presence of water and the initiation for cure shall be less than 180° F (82.2° C).

2.1.3. *STRENGTH*

The CIPP shall conform to the following minimum structural standards:

<b>Cured In Place Pipe</b>	<b>Standard</b>	<b>Result</b>
Tensile Stress	ASTM D-638	3,000 PSI
Flexural Stress	ASTM D-790	4,500 PSI
Modulus of Elasticity	ASTM D-790	250,000 PSI

2.1.4. *MINIMUM THICKNESS*

The CIPP shall conform to the following minimum thickness standards:

Pipe Size	Thickness required with 250,000psi <u>Modulus of Elasticity</u>	Thickness required with 400,000psi <u>Modulus of Elasticity</u>
8" pipe	0.178 inches	0.153 inches
10" pipe	0.229 inches	0.196 inches
12" pipe	0.359 inches	0.332 inches

2.1.5. *MINIMUM THICKNESS*

The CIPP shall be designed as per ASTM F1216, Appendix XI. The CIPP design shall assume no bonding to the original pipe wall. The long term Flexural Modulus used in the design shall be verified by independent testing. Such long term Modulus values shall not exceed 50% of the short-term values given in Section 2.3 above. The CIPP thickness shall not be less than those shown above in Section 2.4 for the given physical properties.

2.2. HIGH DENSITY POLYETHYLENE PIPE (HDPE)

2.2.1. *MATERIAL*

The liner pipe shall be made of a polyethylene pipe compound that meets the requirements of Type III, Grade P34 polyethylene material as defined in ASTM D-1248. The outside diameter and minimum wall thickness shall conform to an SDR of 32.5 when measured in accordance to ASTM D-2122.

### 2.2.2. *SIZE*

The size of pipe to be used shall be as shown on the plans.

### 2.2.3. *STRENGTH*

When the environmental stress cracking resistance (ESCR) of the material is measured in accordance with ASTM D-1693, the material shall withstand not less than 100 hours in 25 percent solution IGEPAL CO-630 or 1,000 hours in 100 percent IGEPAL CO-630 before reaching a 50 percent failure point ( $F_{50}$ ).

The polyethylene pipe shall have a manufacturer's recommended hydrostatic design stress rating of 710 psi based on a material with a 1420 psi design basis determined in accordance with ASTM D-2837, Standard Method for Obtaining Hydrostatic Design Basis for Thermoplastic Pipe Materials.

Workmanship shall be of the highest level compatible with current commercial practice. The PE pipe shall be homogeneous throughout and free of visible cracks, holes, foreign inclusions, or other injurious defects. It shall be uniform in color, opacity, density and other physical properties.

Marking on the pipe shall include the following at intervals of not more than five feet:

1. Nominal pipe size.
2. The type of plastic material, i.e., P.E. 3406.
3. The standard thermoplastic pipe dimension ratio (SDR) or Schedule number.
4. Manufacturer's name or trade mark and code.

Tests for compliance with this specification shall be made as specified herein and according to the applicable ASTM specification. A certificate of compliance with this specification, along with a report of each test, shall be furnished by the manufacturer for all material furnished under this specification.

### 1. Tensile Properties

The tensile strength, yield strength, elongation and elastic modulus of the material shall be determined in accordance with ASTM D-683. ASTM D-638 shall be used to determine that the thermal butt-fusion joints are stronger than the materials joined.

### 2. Melt Index

The melt index of the polyethylene resin shall be determined in accordance with ASTM D-1238 and shall be equal, or between 0.1 g/10 min. and 1.0 g/10 min.

### 3. Density

The density of the base polyethylene resin shall be determined in accordance with ASTM D-1505 and be equal or between .941 g/cc and .955 g/cc.

### 4. Environmental Stress Cracking Resistance

The material shall be tested in accordance with ASTM D-1693. The test reagent shall be IGEPAL CO-630 in 25 percent solution by volume. The specimens shall be in the solution not less than 100 hours before a 50 percent failure point (F 50).

### 5. Rejection

Polyethylene pipe may be rejected for failure to meet any of the requirements of this specification.

### 6. Sustained Pressure

The pipe shall not fail, balloon, burst or weep as defined in ASTM D-1598 when tested in accordance with ASTM D-2239.

### 2.3 MANHOLE RESTORATION

#### *2.3.1. MANHOLE RELINER - STEP ONE (MORTAR)*

##### 2.3.1.1. THICKNESS OF MORTAR

The restorative liner material shall be specifically designed for the rehabilitation of manholes and other related structures and be compatible with the type of fluid and gases expected to be present in the manhole. Liner materials shall be mixed with water as per manufacturer's written specifications and applied using equipment specifically designed for either low pressure spray or centrifugal spin casting application of cement mortars. All cement liner materials must be capable of a placement thickness of ½" to 4" in a monolithic application. All mortars shall be transported to the construction site in original manufacturer's bags (not less than 50# each).

##### 2.3.1.2. STRENGTH OF MORTAR

Restorative liner materials shall be cement based, and contain microsilica, thermoplastic fibers, densifiers, polymer admixtures and other modifiers that produce a high strength, low shrinkage and low permeability mortar. Mortar shall not contain calcium aluminate cements or aggregates.

All restorative liner materials shall conform to the following 28-day minimum physical properties:

- A. Compressive Strength (ASTM C 109): 6000 psi
- B. Tensile Strength (ASTM C109): 575 psi
- C. Flexural Strength (ASTM C 78): 985 psi
- D. Shrinkage (ASTM C 157): 0.04%
- E. Uniaxial Tensile Bond Strength (ACE 503R Appendix A): >500 psi over high strength concrete; 150 psi minimum acceptable bond

Approved manufacturer: Mainstay ML-72 Sprayable Microsilica Cement Mortar or approved equal.



*2.3.2. MANHOLE RELINER - STEP TWO (EPOXY COATING)*

The epoxy coating shall be 100% Solids, 2 component, modified epoxy coating with a gloss finish. The epoxy coating shall be capable of application to restorative liner material immediately after the liner has been sprayed, troweled and sponge finished (while restorative liner is in a soft, uncured state).

The epoxy coating shall be off white in color. The epoxy coating shall be capable of being applied in one or two coats. The epoxy shall be applied at a minimum of 50 mils.

Epoxy thickness shall be no less than a uniform 50 mils. If additional epoxy is required at any level, the rotating applicator head shall be placed at that level and application shall commence until that area is thickened.

Approved manufacturer: Mainstay DS-5 Ultra High Build Epoxy Coating or approved equal.

**PART 3**  
**CONSTRUCTION**

3.1. CURED IN PLACE PIPE (CIPP)

The following installation procedures shall be adhered to unless otherwise approved by the Engineer:

*3.1.1. SAFETY*

The installer shall carry out his operations in strict accordance with all OSHA and manufacturers safety requirements. Particular attention is drawn to those safety requirements involving working with scaffolding and entering confined spaces.

*3.1.2. CLEANING OF PIPES AND OBSTRUCTIONS*

Prior to installation, the Contractor shall clean the line that is to receive the liner. It shall be the responsibility of the installer to clear the pipe of obstructions such as solids, protruding service connections, or collapsed pipe that could prevent insertion of the liner or adherence to the pipe wall. If inspection reveals an obstruction that cannot be removed by conventional pipe cleaning equipment, the Contractor shall make a point repair excavation to remove or repair the obstruction. Such excavation shall be approved in writing by the Engineer prior to the commencement of the work and shall be considered as a separate pay item.

*3.1.3. INSPECTION OF ORIGINAL PIPE*

Inspection of the original pipe shall be performed by experienced personnel trained in locating breaks, obstacles and service connections by closed circuit television or man-entry. The interior of the pipe shall be carefully inspected to determine the location of any conditions that may prevent the proper installation of the liner. A videotape and log noting all services and defects shall be submitted to the Engineer for future reference.

*3.1.4. RESIN IMPREGNATION*

The tube should be vacuum-impregnated with resin (wet-out) under controlled conditions. The volume of resin used shall be sufficient to fill all voids in the tube

material at nominal thickness and diameter. The volume shall be adjusted by 5-10% excess resin for the change in resin volume due to polymerization and to allow for any migration of resin into the cracks and joints in the original pipe.

### *3.1.5. NOTIFICATION*

The Contractor shall notify all parties who will be affected by the lining operation. For sanitary sewers, the notice shall advise against water usage until the lateral is reconnected and the sewer back in service.

### *3.1.6. INSTALLATION OF THE LINER*

The Contractor shall designate a location where the uncured resin in the original containers and the unimpregnated tube will be vacuum impregnated prior to installation. The installer shall allow the Engineer to inspect the materials and “wet out” procedure. A resin and catalyst system compatible with requirements of this method shall be used. The quantities of the liquid thermosetting materials shall be per manufacturer's standards to provide the wall thickness specified.

### *3.1.7. INVERSION*

The wet out tube shall be inserted through an existing manhole or other approved access by means of an inversion process and the application of a hydrostatic head, air pressure or mechanical means sufficient to fully extend the tube to the next designated manhole or termination point. The tube shall be inserted into the vertical inversion standpipe or guide chute with the impermeable plastic membrane side out and attached with a leak proof seal. The hydrostatic head or air pressure shall be adjusted to cause the impregnated tube to invert from the point of inversion to the point of termination, turning the tube inside out and holding the tube tight to the wall, producing dimples at lateral connections. Care shall be taken to avoid overstressing the fabric. The tube manufacturer shall provide information on the maximum allowable tensile stress for the tube.

Before the inversion begins, the tube manufacturer shall provide the minimum pressure required to hold the tube tight against the existing conduit and the maximum allowable pressure so as not to damage the tube. Once the inversion has started, the pressure shall be maintained between the minimum and maximum pressures until the inversion has

been completed. If the pressures are not maintained, the tube shall be removed from the pipe.

### *3.1.8. LUBRICANT*

The use of a lubricant during inversion shall be used to reduce friction during inversion. The lubricant shall be a nontoxic, oil-based product that has no detrimental effect on the tube, does not support bacteria growth or affect the general characteristics of the fluid to be carried by the pipe.

### *3.1.9. CURING*

After inversion has been completed, the inversion water shall be uniformly raised above the temperature required to effect a cure of the resin as recommended by the manufacturer. The inversion water shall be recirculated by means of a pump throughout the tube and temperature monitors shall be placed on the ingoing and outgoing lines to determine that the correct temperature is maintained. Additionally a temperature gauge shall be installed between the tube and the pipe invert at the termination point to determine temperatures during cure.

If steam is used to cure the tube, the temperature within the tube shall be uniformly raised by means of steam generating equipment. Temperature gauges shall be placed on the outgoing line and also gauges shall be placed between the tube and invert of the existing pipe at both the upper and lower ends of the pipe to determine the temperature during cure.

The recommended temperature shall be held for the length of time recommended by the resin manufacturer. Initial cure occurs during heat up and is indicated when the exposed portions of the tube appear to be hard and sound and the remote temperature sensor(s) indicate that the temperature is of a magnitude to realize an exotherm or cure in the resin. The temperature should then be raised to post cure temperatures and held for the duration recommended by the resin manufacturer.

Pressure shall be maintained as per the manufacturer's recommendations to hold the flexible tube tight against the existing pipe. This pressure shall be maintained until the cure has been completed.

The Contractor shall provide a continuous log of the designated temperatures and pressures during the time of the cure. The Contractor shall also furnish the Engineer with the resin manufacturers recommended cure temperatures and pressures prior to the start of the inversion process.

#### *3.1.10. COOL DOWN*

The liner pipe shall be cooled down to a temperature below 100° F (113° F for steam cured) before relieving the internal pressure. Cool down may be accomplished by introducing cool water into the section as the water and/or steam is drained off through a small hole in the downstream end. Care must be taken to avoid causing a vacuum that could damage the newly installed pipe.

#### *3.1.11. FINISH*

The finished CIPP shall be continuous over the entire length between manholes and be free from visual defects such as foreign inclusions, dry spots, lifts, pinholes or delamination. The new pipe shall be free of leaks and any defects that will affect the integrity or strength of the CIPP shall be repaired at the Contractor's expense in a manner acceptable to the Engineer.

#### *3.1.12. SEALING CIPP AT MANHOLES*

Hydrophilic seals shall be used to achieve a watertight connection at manholes. If the CIPP fails to make a tight seal at the manhole walls the Contractor shall apply a resin mixture seal at that point. The resin seal shall be compatible with the resin mixture of the CIPP.

#### *3.1.13. SERVICE CONNECTIONS*

After the new pipe has been cured in place, the Contractor shall reconnect all existing active service connections. This shall be done without excavation by means of a television camera and cutting device or by man entry and a cutting device. The services shall be restored to not less than 90% of their original capacity and shall be free of any sharp edges or protrusions, which could cause paper, rags or debris to accumulate.

### *3.1.14. INSPECTION*

Two CIPP samples shall be prepared for each inversion length between manholes. The samples shall be fabricated from material taken from the tube and the resin/catalyst system used. The samples shall be clamped between flat plates and the mold placed in the downtube when circulating water is used or in the silencer when steam is used. The samples shall be large enough to provide a minimum of five specimens for flexural and tensile testing. After curing, the samples will be submitted to an independent testing firm to confirm the finished product meets the requirements of these Specifications.

## *3.2. HIGH DENSITY POLYETHYLENE PIPE (HDPE)*

### *3.2.1. LINE OBSTRUCTION*

Prior to commencing sliplining, the Contractor will clean the line that is to receive the polyethylene liner. It shall become the responsibility of the Contractor to clear the line of any protruding service connections or solids that might prevent the pulling of the lines through the existing sewer. In particular, debris or other materials should be removed from the bottom of the original pipe so that the inserted pipe will not be resting on or against nor be irregularly supported by such materials. Should the liner become jammed while being pulled, the Contractor shall excavate over the point of obstruction to clear the liner.

Immediately before the insertion operation, it may be desirable to pass a test-head of the same diameter as the polyethylene pipe to be inserted through the original pipe to ensure free passageway. Test-heads shall be attached to pulling cables at both ends.

### *3.2.2. EXCAVATION*

Excavation shall conform to the requirements herein set forth, as called for on the drawings or as otherwise approved in writing by the Engineer or his representative.

“Pulling pits” will be required at intermediate manholes or other intermediate points where the liner pipe will be “fed” into the existing sewer. These excavations should be kept to a minimum size and coincide with building service connection excavations or critical deviations in line or grade whenever possible.

### 3.2.3. *HANDLING PIPELINE*

Pipe shall be stored on clean level ground to prevent undue scratching or gouging. Sections of pipes with deep cuts or gouges shall be removed completely and the ends of the pipeline rejoined. The handling of the joined pipeline shall be in such a manner that the pipe is not damaged by dragging it over sharp and cutting objects.

Pipe should be inspected for damage immediately prior to joining. Damage will consist of: (1) serious abrasion, cutting, or gouging of the outside surface extending to more than 10% of the wall thickness in depth; (2) kinking due to excessive or abrupt bending; (3) flattening, particularly if localized over short lengths of the pipe amounting to more than 5% of the original diameter; and (4) any abrasion or cutting of the inside surface. Damaged portions should be cut out and discarded. The resulting short lengths may be used as such or rejoined by the butt fusion procedure.

### 3.2.4. *FUSION JOINTING*

Joining shall be by the heating and butt-fusion method and in strict conformance with the manufacturer's recommendations and ASTM D-2657. Polyethylene pipe lengths to be fused shall be the same type, grade and class of polyethylene compound and supplied by the same raw material supplier.

Joining of the pipes and fittings shall be performed in accordance with the procedures recommended by the pipe manufacturer. Depending upon the installation requirements and site location, joining shall be performed within or outside the excavation. Joints between pipe sections shall be smooth on the inside and internal projection beads shall not be greater than 3/16 inch. Unacceptable joints shall be cut out and the joint redone.

The tensile strength at yield of the butt-fusion joints shall not be less than that of the pipe. A specimen of pipe cut across the butt-fusion joints shall be tested in accordance with ASTM D-638.

Where excavations for insertion of the polyethylene liner are made in a line section between two manholes, the polyethylene pipe will be joined together with a stainless steel water main repair sewer. The exposed liner and clamp shall then be encased with stabilized sand.

### 3.2.5. *INSERTION OF LINER PIPE*

Prior to insertion of the liner pipe, the Contractor shall saw and remove the pavement over the existing services to allow for speedier hookup of the services. The liner pipe shall be pulled into the sewer by use of winches and pulling heads. Pushing of the liner into the sewer will not be allowed.

Where installation of liner pipe is to be in “pulling pits”, the existing sewer shall be exposed to springline for the full length of the pit prior to removal of the crown portion of a section of the existing main. The flow line of the existing sewer shall be maintained. Only one pulling pit will be allowed on this project and the location is shown on the plans.

A power winch shall then be connected to the end of the liner by use of a metal pulling head, so the liner can be fed into the existing sewer. Precautions shall be taken not to damage the liner or break any of the joints. It may also be necessary to put guards over the edges of the existing pipe at the inlet end to prevent their gouging the polyethylene pipe during the insertion procedure.

A sturdy pulley frame must be constructed at the base of a manhole or shaft, capable of withstanding the substantial force required to move the pipe being inserted. The winch, usually placed on the surface at the head of the manhole or shaft must usually be powered; but a geared, hand-operated winch may be sufficient for the insertion of small piping. Load controls are desirable to prevent overstressing the equipment in case of a blockage.

When liner pipe of the same diameter is extended into a straight-through manhole, the pipe ends shall be butted against the other liner pipe and the top one-third cut out and a concrete shell poured to match this cut.

Length of the liner pipe to be pulled into an existing sewer at any one time shall be governed by the size of sewer being sliplined and condition of the existing sewer.

### 3.2.6. *ELONGATION*

The insertion operation often proceeds with a “slip-stick” action. Particularly when pulling, means of coordinating the feed of pipe into the entrance with operation of the



winch is desirable. The pulling operation will tend to stretch the pipe, and excessive stretching (more than 1.5%) should be avoided. The pulling speed is unlikely to exceed about 300 mm/s (1 ft/s), and slower speeds will be necessary under the more difficult conditions. Once started, the operation should continue without interruption until completed.

On reaching the exit point, the pipe should be pulled beyond this point as advised by the coordinator, at the entrance point. Stretching of about 1% of the total length pulled will often be observed. This stretching will be recovered over a period of time about equal to the length of time it took to complete the pull. If the work is done during warm weather, an additional contraction may also be observed. This can be as much as 20 mm/30 m-5°C (1 in./100 ft-10°F) difference in temperature between the pipe before and after installation and this should be allowed for in the length of insertion pipe used.

When stabilization is complete, anchoring and grouting can be done.

### *3.2.7. SERVICE CONNECTIONS*

After the liner has been pulled into place and secured in the manhole walls, each existing service connection shall be reconnected to the new liner in accordance with the Specifications. A portion of the existing sewer around each service connection shall be removed to expose the liner pipe and provide sufficient working space for making the new service connection.

Service connections shall be made with the use of PVC saddle. The liner shall be cut with the use of a template. The connection shall be watertight and the saddle attached to the main with stainless steel ring clamps.

The Contractor shall be responsible for damages caused by plugged or blocked sewer services. Upon report of a blocked service, the Contractor shall immediately excavate down at that service to alleviate the problem before continuing any other work.

### *3.2.8. BACKFILL*

At all points where the liner pipe has been exposed, as in pulling pits, service connections, outside of manholes, etc., the Contractor shall remove all debris and create a void along each side of the pipe at springline to undisturbed soil, in preparation for gravel

backfill. Width of the void shall not exceed (liner diameter plus 2 feet) or (service diameter plus 2 feet). Controlled density fill shall be placed along the sides and to a point one foot above the liner pipe and level across the trench. Care shall be exercised at all times to prevent damage or collapse to the polyethylene liner, service connections, etc. Should the bottom be unstable, the Contractor shall use compacted pea gravel to the bottom of the liner pipe.

After the controlled density fill is in place and accepted by the Engineer, gravel backfill under streets and excavated material under boulevards shall be placed and compacted to finished grades in accordance with the Specifications.

### 3.3. MANHOLE RESTORATION

#### *3.3.1. MANHOLE PREPARATION*

The floor and interior walls of the manhole shall be thoroughly cleaned and made free of all foreign materials including dirt, grit, roots, grease, sludge and all debris or materials that may be attached to the wall or bottom of the manhole. A high pressure wash with a minimum pressure of 4500 psi shall be used to clean and free all foreign material within the manhole. When grease and oil are present, an approved detergent shall be used integrally with the high pressure cleaning water. All materials resulting from the cleaning of the manhole shall be removed prior to application of the restorative liner. All loose or defective brick, grout, ledged, steps and protruding ledges shall be removed to provide an even surface prior to application of cement based coating.

#### *3.3.2. SEALING ACTIVE LEAKS FOR MANHOLE RELINER*

If active leaks are detected prior to placement of the restorative liner, hand apply a dry quick-setting cement based mix designed to instantly stop running water or seepage. The applicator shall apply material in accordance with manufacturer's recommendations and following specifications:

- A. The area to be repaired must be clean and free of all debris.
- B. Once cleaned, prepare crack or hole by chipping out loose material to a minimum depth and width of  $\frac{3}{4}$  inch.

- C. With gloved hand, place a generous amount of the dry quick-setting cement based material to the active leak, with a smooth fast motion, maintaining external pressure for 30 seconds, repeat until leak is stopped.
- D. Proper application should not require any special mixing of product or special curing requirements after application.

### 3.3.3. *MANHOLE RELINER APPLICATION - STEP ONE (MORTAR)*

Material shall be mixed with water in accordance with manufacturer's specifications. Once mixed to proper consistency, the materials shall be pumped via a rotor-stator style progressive cavity pump through a hose.

Material hose shall be coupled to a high speed rotating applicator device. The rotating applicator shall then be positioned within the center of the manhole at either the top of the manhole chimney or the lowest elevation at the junction of the manhole bench and walls.

The high speed rotating applicator shall then be started and material pumping shall commence. As the mortar begins to be centrifugally cast evenly around the interior of the manhole, the rotating applicator head shall be raised and/or lowered at a controlled retrieval speed to provide a uniform material thickness on the manhole walls.

Controlled multiple passes are made until the specified minimum thickness is achieved. If the procedure is interrupted the applicator head is stopped until flows are restored.

Material thickness may be verified at any point with a depth gauge and shall be no less than 1 inch. If additional material is required at any level, the applicator head shall be placed at that level and application shall commence until that area achieves the specified thickness.

Material shall be applied only when manhole is in a damp state with no visible water dripping or running over the manhole walls.

The low-velocity spray nozzle and the centrifugal spin casting head may be used in conjunction to facilitate uniform application of the mortar material to irregularities in the contour of the manhole walls and bench areas.

Troweling and sponge finishing shall begin immediately following the spray application of the mortar.

*3.3.4. MANHOLE RELINER APPLICATION - STEP TWO (EPOXY COATING)*

All epoxy coatings shall be designed specifically for the rehabilitation of manholes and other related waste water structures. The epoxy coating shall be designed to be applied to newly placed mortar immediately following the placement (by centrifugal spin casting) and troweling of the mortar. **This process shall begin no more than four hours following placement of the mortar. The mortar must be in a soft, uncured, plastic state.**

Epoxy hose shall be coupled to a high speed rotating applicator device. The rotating applicator shall then be positioned within the center of the manhole at either the top of the manhole chimney or lowest elevation at the junction of the manhole bench and walls.

The high speed rotating applicator shall then be started and pumping of the epoxy shall begin. As the epoxy begins to be centrifugally cast evenly around the interior of the manhole, the rotating applicator head shall be raised and/or lowered to provide a uniform epoxy thickness on the manhole walls.

Controlled multiple passes are then made until the specified minimum thickness is attained. If the procedure is interrupted for any reason, stop the applicator head until flows are recommenced.

Curing will take place once the manhole cover has been replaced. Plastic sheeting is installed below the manhole lid so the lid does not bond to the structure. The plastic sheeting also prevents foreign objects from embedding in the fresh epoxy.

**PART 4**  
**GUARANTEE, MEASUREMENT & PAYMENT**

4.1. GUARANTEE

The guarantee shall be per the contract.

4.2. MEASUREMENT AND PAYMENT

*4.2.1. CURED IN PLACE PIPE*

The CIPP will be paid on the actual number of feet of the various sizes of liner installed, as measured along the centerline of the existing pipe between the manholes or to the ends of the liner installed. Payment shall include furnishing and installing the liner, curing, sealing at the manholes, cleaning and televising, bypassing of sewage, insertion equipment and all incidentals required to reline the existing pipe in place and accepted.

*4.2.2. SEWER SERVICE RECONNECTION*

All costs of making sewer service reconnections shall be included in the contract unit price for Reconnect Sewer Service.

*4.2.3. CLEANING AND TELEVISIONING*

Cleaning and televising costs shall be included in the contract unit price for the pipe being rehabilitated.

*4.2.4. PUMPING SEWAGE*

All costs associated with the bypassing of sewage shall be included in the contract unit price for the pipes or manholes being rehabilitated.

#### *4.2.5. HIGH DENSITY POLYETHYLENE PIPE (HDPE)*

The quantity to be paid for shall be the actual number of linear feet of liner pipe installed, as measured along the centerline of the existing main between manholes or to ends of liner installed. Payment for slipliner pipe shall include furnishing and installing liner piping, thermal jointing, circle seal clamping, manhole sealing, sewer cleaning, pulling equipment, bypassing sewage, televising, and all other incidentals required to slipline an existing main complete in place and accepted.

#### *4.2.6. PULLING PITS*

All costs for providing pulling pits shall be included in the contract unit price per linear foot of HDPE liner pipe. The pavement removal, gravel backfill and pavement replacement will be paid for at contract unit prices.

#### *4.2.7. LINE OBSTRUCTION*

All work done to clear a jammed liner during pulling will be considered incidental to the contract and no extra payment shall be made. The pavement removal, gravel backfill and pavement replacement will be paid for at contract unit prices.

#### *4.2.8. DEWATERING*

Except where a bid item exists, all costs for any necessary dewatering shall be included in the price bid for other items.

#### *4.2.9. MANHOLE RESTORATION*

All costs associated with manhole restoration shall be paid at the contract unit price per linear foot for Manhole Liner. The measurement shall be from the manhole floor to the top of the liner.

**CITY OF FARGO SPECIFICATIONS  
EXCAVATION, FILLING, AND SUBGRADE PREPARATION**

**PART 1  
DESCRIPTION OF WORK**

The work to be done under this section of the Specifications and the accompanying plans consists of all labor, material, accessories, and equipment necessary to perform excavations, fills, embankments, subgrade preparation, topsoiling, and such other work and incidentals as may be necessary to properly complete the work.

**PART 2**  
**MATERIAL**

2.1. TOPSOIL

*2.1.1. TOPSOIL - IMPORT*

Imported topsoil shall be fertile loamy material having a pH between 5.5 and 6.5 that is free from roots, vegetation or other debris of such size and quantity that prevents proper placement of the topsoil, free of stones and clods over 1/2-inch in greatest dimension, and free from noxious weeds, seeds and/or roots.

*2.1.2. TOPSOIL – IMPORT SPECIAL*

If specified, TOPSOIL – IMPORT SPECIAL shall be fertile loamy material having a pH between 5.5 and 6.5 that is screened so as to be completely free from rhizomes, roots, vegetation, stones, clods, noxious weeds, seeds, roots, and/or other debris.

*2.1.3. SALVAGED TOPSOIL*

Topsoil that is stripped and reused on the site shall be free from roots, vegetation or other debris of such size and quantity that prevents proper placement of the topsoil, free of stones and clods over 1/2-inch in greatest dimension.

2.2. IMPERVIOUS FILL

Clay for levees shall be cohesive and consist of material classified by ASTM D-2487 as CL or CH. Gradation shall not have less than 40% by weight passing the No. 200 sieve. The liquid limit (L.L.) shall be greater than 25% and plasticity index (P.I.) greater than 10 percent. The material shall be free of ice, snow, frozen earth, trash, debris, sod, roots, organic matter including silts which are unstable, inorganic materials too wet to be stable or stones larger than 3-inches in any dimension.

2.3. BORROW MATERIAL

The Contractor shall be responsible for securing borrow material for completing embankment construction unless a borrow site is supplied by the city of Fargo and identified in the



accompanying plans. Borrow material for embankment construction shall meet the requirements for Impervious Fill as described above.

**PART 3**  
**CONSTRUCTION**

3.1. LOCATION AND PROTECTION OF EXISTING UTILITIES

The location of the public or private utilities may be shown on the plans, as reported by the various utility companies and the City, but this does not relieve the Contractor of the responsibility of determining the accuracy or completeness of said locations. North Dakota law requires the Contractor to contact ND One-Call at 800-795-0555 prior to any underground interference. The Contractor shall protect all trees, shrubs, manholes, water shut-off, survey monuments, or any other existing utilities from damage. Any utilities that are damaged during the course of the work shall be repaired or replaced to the satisfaction of the Engineer at the Contractor's expense.

3.2. CLEARING, GRUBBING, AND TREE REMOVAL

Clearing, grubbing, and tree removal shall be in accordance with Section 1050 of these Specifications.

3.3. TOPSOIL

The Contractor shall remove and stockpile all topsoil in areas of excavation as delineated in the field by the Engineer in accordance with Section 1050 of these Specifications.

Immediately prior to placing the topsoil, the subgrade shall be loosened by disking or scarifying to a depth of two inches to provide for the bonding of the topsoil to the subgrade. Topsoil shall be placed on all areas to meet prescribed thicknesses and grades to provide soil capable of supporting grass growth in accordance with *BOULEVARD FILLING AND GRADING* below. Topsoil shall be graded to drain then moderately compacted by use of a soil-roller or other Engineer-approved method. Irregularities or low spots resulting from the topsoiling or other operations shall be corrected in order to prevent pockets where water may stand. Topsoil shall not be placed when the subgrade is frozen, excessively wet, extremely dry, or in a condition otherwise detrimental to the proposed plantings or the grading operation.

### 3.4. EXCAVATION

This item shall include all labor and appliances necessary to bring the subfoundation to the desired subgrade elevation. The subgrade shall be defined as the area inside one-foot (1') behind the back of curb, and to the alley paving limits in the case of excavation prior to the paving of streets.

This item shall include the grading of the roadway to meet alley returns.

Excavated material shall be removed to the approximate elevation of the subgrade and deposited at locations designated by the Engineer. The free haul under this item shall not exceed one mile one-way unless indicated otherwise.

Material excavated from any part of this contract, if used as fill on this contract, shall be paid for only under excavation and not as "fill".

#### *3.4.1. SUBCUT*

After the excavation work has been completed, the Engineer will be the sole judge as to whether a subcutting operation will be required to correct an unstable or extremely wet subgrade condition. The decision on whether to subcut will not be a Contractor's option. In no way should this subcut item be misconstrued to be used to correct situations resulting from rainfall during construction, which require drying operations at the Contractor's expense.

Unless otherwise approved by the Engineer, the subcutting operation shall be performed in the following manner:

- A. Soil shall be hauled out of the unstable area for the entire width of the excavation to the depth directed by the Engineer.
- B. The excavated or subcut area shall then be scarified to a depth of 6 inches, dried to a moisture content within 5% of optimum and compacted to a minimum of 90% of Standard Proctor density with equipment specifically designed to uniformly compact the soil.
- C. The Contractor will be required to allow sufficient time for the City to cross-section the subcut area before the backfilling process begins.

- D. The Contractor shall aerate the subcut/excavation area to achieve a uniform working platform on which to begin construction of a suitable subgrade. This work shall be done prior to the start of backfilling operations.
- E. Fill shall then be placed per the requirements specified for Fills and Embankments.

#### *3.4.2. DISPOSAL OF EXCESS MATERIAL*

All excess excavated material shall become the property of the Contractor and shall be disposed of away from the work site at such locations and in such a manner as the Engineer may direct. The Contractor shall furnish a dump person at no expense to the City. Broken concrete, asphalt, and other similar materials shall be separated from the earth fill and hauled to the City of Fargo landfill.

Stockpiling: On projects where the City retains ownership of the excess material at a site designated on the plans or special instructions, the Contractor shall stockpile the material. These costs to haul and shape the material to a drainable, mowable stockpile shall be included in the cost of other bid items.

#### *3.5. FILLS AND EMBANKMENTS*

Fills and embankments as required by the plans shall be constructed with earth obtained from the excavation to the maximum extent possible. Material used in fills or embankments shall be free of organic or other objectionable material. Unsuitable fill material shall be disposed of per the requirements specified above for Excess Material.

Before any fill is placed on the existing subgrade it shall be scarified and compacted per the requirements specified above for Subcut. Fill shall then be placed in successive horizontal layers not to exceed six (6) inches uncompacted thickness and spread and leveled prior to compaction. Each layer shall be properly compacted to 95% of Standard Proctor density at the optimum moisture content  $\pm$  3%. Compaction shall be accomplished by equipment specifically made to uniformly compact the soil. Areas of the fill inaccessible to rollers or compactors shall be compacted by hand tampers to the required density.

Motor graders or other equipment acceptable to the Engineer shall be used on each lift to spread the material and to obtain uniform thickness before compacting. As the compaction of each layer

progresses, continuous leveling, disking, and manipulating shall be provided to assure uniform soil distribution, moisture, and density control. Construction equipment shall be routed uniformly over the entire surface of each layer; and, if open to traffic, the embankment shall be maintained so that the public can safely traverse the work area.

Benching shall be required whenever embankment is placed against slopes 4:1 and steeper. The back of the bench shall be nearly vertical with the horizontal cuts being made as close together as slope permits, but with no step being less than 24 inches in width. Each horizontal cut shall begin at the intersection of the original ground and the vertical sides of the previous cuts. Excavated material shall be recompacted along with new embankment material. The cost for benching and recompacting shall be included in the price bid for other items.

### 3.6. PREPARATION OF SUBGRADE FOR PAVING

After the cross sections have been completed, the entire subgrade shall be scarified to a depth of not less than six (6) inches and compacted. The material shall be compacted to 95% of Standard Proctor density at the optimum moisture content +/-3%. In no case shall the moisture content of the soil being compacted exceed 30%. If the elevation of the subfoundation is below the desired level after rolling, suitable fill shall be added and compacted in accordance with this Specification. Areas of the fill inaccessible to rollers or compactors shall be compacted by hand tampers to the required density.

Fine grading shall be finished for a suitable distance ahead of the paving to allow adequate time for a final check for finished grade and compaction. No paving shall be started until the results of the compaction tests are known, the final grade has been checked, and the Contractor has been given the notice to proceed by the Engineer. Final grade shall be within 1/2" (0.04').

After completing the subgrade preparation, the Contractor shall take appropriate action to eliminate all unnecessary traffic on the prepared subgrade prior to placing the aggregate base.

#### *3.6.1. SUBGRADE PREPARATION FOR ASPHALT PAVING*

The finished surface of the subgrade must be parallel to the planned finished surface of the asphalt wearing course, and at the necessary elevation to allow for the thickness of the specified aggregate base, the asphalt base course, and the asphalt wearing course.

### *3.6.2. SUBGRADE PREPARATION FOR CONCRETE PAVING*

The finished surface of the subgrade must be parallel to the planned finished surface of the concrete pavement, and at the necessary elevation to allow for the thickness of the concrete pavement and the specified aggregate base.

### *3.6.3. SUBGRADE PREPARATION FOR SEPARATE CONCRETE CURB AND GUTTER*

The finished surface of the subgrade must be parallel to the planned finished surface of the concrete curb and gutter, and at the necessary elevation to allow for the thickness of the concrete curb and gutter and the specified aggregate base.

### *3.6.4. SUBGRADE PREP FOR SIDEWALKS, DRIVEWAYS, AND IMPRESSIONED CONCRETE*

The finished surface of the subgrade must be parallel to the planned finished surface of the concrete, and at the necessary elevation to allow for the thickness of the concrete section and a two (2) inch minimum aggregate base.

## *3.7. BOULEVARD FILLING AND GRADING*

When the plans call for filling and/or grading of boulevards or when the construction activity occurs in built up areas, this item shall include all labor, material, and equipment to properly level backfill, compact to 90% of Standard Proctor within 5% of optimum moisture, and level the boulevards with topsoil between the curb and the property line or the present sidewalk line. When well-established boulevards already exist, the backfilling shall blend into the present boulevard.

The above work shall be done as follows:

- A. All debris shall be removed from behind the curb, such as wood, rock concrete and other debris that may hinder the work.
- B. Before the topsoil is placed behind the curb on new construction projects, boulevard dirt shall be brought to a straight grade from four inches below the sidewalk to four inches below the top of the curb. For reconstruction projects, boulevards shall be uniformly graded and have at least 4" of moderately compacted topsoil spread.

- C. All curb stop boxes shall be raised to finished grade.
- D. The top four inches shall be native topsoil only, free of sod, hard lumps, gravel, rocks, subsoil, or other undesirable material.
- E. No equipment weighing more than the average lawn-building equipment will be allowed on the boulevards during the placing and leveling of the topsoil.
- F. Backfilling shall be done as soon as possible after the adjacent concrete slabs, curbs, sidewalks or driveways achieve a strength of 3,000 psi.

The City Water Department will be checking all curb stop boxes for straightness at the end of the project. Deficiencies shall be corrected by the Contractor at his sole expense.

**PART 4**  
**GUARANTEE, MEASUREMENT & PAYMENT**

4.1. GUARANTEE

The guarantee shall be per the contract.

4.2. MEASUREMENT AND PAYMENT

*4.2.1. CLEARING, GRUBBING, AND TREE REMOVAL*

Payment for clearing, grubbing, and tree removal will be per Section 1050 of these Specifications.

*4.2.2. TOPSOIL*

Topsoil will be paid as follows:

- A. TOPSOIL STRIPPING: Topsoil stripping shall be in accordance with Section 1050 of these Specifications.
- B. TOPSOIL SPREADING: Topsoil spreading items shall be paid for at the contract unit price for the various items, and shall include placement and finish-grading. Cubic-yard quantities shall be computed by the Engineer by multiplying the thickness times the measured square-yardage.
- C. TOPSOIL IMPORT and IMPORT SPECIAL: Payment for topsoil import shall include the supply, transport, placement, and finish-grading of topsoil meeting the requirements of this section of the Specifications.

*4.2.3. EXCAVATION*

Excavation quantities will be calculated from one foot behind back of curb to one foot behind back of curb and will be paid for at the contract unit price bid per cubic yard. The cubic yard of excavation shall be determined by cross sections using the average end area method.



#### 4.2.4. *SUBCUT EXCAVATION*

Subcut excavation quantities will be calculated by the average end area method over the subgrade area as defined in section 3 above, and will be paid for at the contract unit price bid per cubic yard. The unit price shall include all costs necessary to satisfactorily complete the subcutting operation.

#### 4.2.5. *SUBGRADE PREPARATION*

Subgrade preparation will be paid for at the unit price bid per square yard for the area of the subgrade as defined in section 3 above.

#### 4.2.6. *FILLS AND EMBANKMENTS*

The cost of placing and compacting fills and embankments when using materials excavated under this contract shall be included in the contract unit bid price per cubic yard of excavation, unless fill is specifically provided for in the bid sheet as a bid item and addressed in the special instructions.

#### 4.2.7. *BOULEVARD FILLING AND GRADING*

All costs for boulevard filling will be paid in accordance with *FILLS AND EMBANKMENTS* above. All costs for grading and topsoiling shall be included in the price bid for other bid items unless a bid item is provided on the bid sheet.

#### 4.2.8. *CURB STOP TO GRADE*

All costs for adjusting each curb stop box to finished grade, including any/all necessary extensions, shall be included in the contract unit price for CURB STOP TO GRADE.

#### 4.2.9. *OTHER COSTS*

All other costs for work necessary to properly complete the work specified herein shall not be bid items; the costs shall be charged to other items unless a bid item is specifically included on the bid sheet.

**CITY OF FARGO SPECIFICATIONS  
GEOTEXTILES AND GEOGRIDS**

**PART 1  
DESCRIPTION OF WORK**

The work to be done under this section of the Specifications and the accompanying plans consists of all labor, material, accessories, and equipment necessary to install geotextile fabric or geogrid material as designated in the plans. Generally this item will be used for separation, drainage, and/or reinforcement during the paving operation.

**PART 2  
MATERIAL**

2.1. GEOTEXTILES

2.1.1. GENERAL

Geotextile fabrics shall conform to the Standard Specification for Geotextile Specification for Highway Applications- AASHTO Designation M 288-96 or the latest revision thereof. All property values, with the exception of apparent opening size (AOS) represent minimum average roll values (MARV) in the weakest principle direction. Values for AOS represent maximum roll values.

2.1.2. CERTIFICATION

The Contractor shall provide the Engineer a certificate stating the name of the manufacturer, product name and style, chemical composition of the yarns and any other pertinent information to fully describe the geotextile. The Manufacturer’s certificate shall state that the furnished geotextile meets MARV requirements of the Specifications.

2.1.3. GEOTEXTILE PROPERTIES

2.1.3.A. Woven Geotextile Fabric

The geotextile fabric for reinforcement/separation shall be woven, consisting of a continuous chain of polymeric filaments or yarns of polyester, polypropylene, polyethylene, polyamide, or polyvinylidene chloride formed into a stable network that is water permeable. The material shall meet the following requirements:

Grab Tensile Strength (ASTM D-4632)	300 lbs. min.
Elongation (ASTM D-4632)	15% max.
Trapezoidal Tear Strength (ASTM D-4533)	113 lbs. min.
AOS Sieve Size (US Sieve) (ASTM D-4751)	40
Permittivity (ASTM D-4491)	0.02 - 0.05 sec. <sup>-1</sup>
CBR Puncture Strength (ASTM D-6241)	900 lbs. min.

## 2.1.3.B. Nonwoven Geotextile Fabric

Where specified, the geotextile fabric for separation shall be a nonwoven, AASHTO M 288 Class 2 having the following minimum average roll values (MARV) in the weakest principle direction:

AASHTO M 288 Class 2 requirements:

Weight	D 5261 <u>ASTM Test Method</u>	6 oz/SY			
		<u>Elongation &lt; 50%</u>		<u>Elongation ≥ 50%</u>	
		N	lbs	N	lbs
Grab Strength	D 4632	1100	250	700	160
Sewn Seam Strength	D 4632	990	220	630	140
Tear Strength	D 4533	400	90	250	56
CBR Punct Strength	D 6241	3500	800	1780	400

Additional requirements:

<u>Item</u>	<u>Test Method</u>	<u>Requirement</u>
AOS	ASTM D4751	0.70 mm (max. Avg. roll value)
Permittivity	ASTM D4491	1.5 sec <sup>-1</sup>
Ultraviolet Stability (Retained Strength)	ASTM 4355	min 50% after 500 hrs exposure

## 2.1.3.C. Geotextile Drainage Sock

The geotextile sock shall meet or exceed the requirements of ASTM D6707. Sock shall be knit of polymeric materials, exhibit minimum snag or run potential, be factory-applied so as to maintain uniform installed mass, and conform to the outside diameter of the tubing with a snug fit throughout.

2.2. GEOGRIDS

## 2.2.1. GENERAL

Geogrids are polymer grid structures specifically fabricated for use as soil reinforcement. The Geogrid shall be a uniaxial or biaxially oriented polymer grid structure. All property values represent minimum average roll values (MARV).

### 2.2.2. CERTIFICATION

The Contractor shall provide the Engineer a certificate stating the name of the manufacturer, product name and style, chemical composition of the material and any other pertinent information to fully describe the geotextile. The Manufacturer's certificate shall state that the furnished geogrid meets MARV requirements of the Specifications.

### 2.2.3. GEOGRID PROPERTY REQUIREMENTS

#### A. GEOGRID FOR PAVING GRADE REINFORCEMENT

The Geogrid supplied shall be a polypropylene or polyethylene material with the following requirements:

		<u>Test Method</u>
Aperture size	between 0.75-1.5 inches	ID calipered
Max. Tensile strength	850lb/ft machine direction	GRI GG1
	1300 lb/ft cross-machine direction	GRI GG1
Tensile Modulus@5%	12,000 lb./ft machine direction	GRI GG1
	18,000 lb/ft cross-mchn. direction	GRI GG1
Junction Strength	750 lb./ft min machine direction	GRI GG2
	1200 ln/ft cross-machine direction	GRI GG2
Flexural Rigidity	200,000 mg-cm machine direction	ASTM D1388
Mass per unit area	6.0 oz/sy minimum	

Allowable Products are Tensar BX series, TX series, and BaseGrid 11 or 12.

#### B. GEOGRID FOR SLOPE REINFORCEMENT

The geogrid supplied shall be a high density reinforcement polyethylene material with the following requirements:

Tensile strength @ 5% strain (min)	3,500 lb/ft
Ultimate Tensile strength (min)	5,700 lb/ft
Junction strength (min)	5,700 lb/ft

**PART 3**  
**CONSTRUCTION**

3.1. GEOTEXTILES

*3.1.1. SEAMING*

Seams shall be in accordance with the Construction/Installation Guideline Appendix to the AASHTO M 288-96 Specification.

*3.1.2. CONSTRUCTION SEQUENCE*

- A. The geotextile shall be laid out smooth without wrinkles or folds on the prepared subgrade in the direction of the construction traffic. Adjacent geotextile rolls shall be overlapped a minimum of 2 feet, ends of rolls shall be overlapped 3 feet. On curves, the fabric may be folded or cut to conform to the curves. The fold or overlap shall be in the direction of construction and shall be held in place by staples, pins or aggregate piles. Damaged areas shall be repaired by overlaying the area with sufficient material to overlap on all edges by at least two feet.
  
- B. When placing aggregate base over geotextiles, overstressing the soil shall be avoided by utilizing equipment in spreading and dumping aggregate base that exerts only moderate pressures on the subgrade. The aggregate base material shall be placed by end dumping onto the geotextile from the edge or over previously placed base aggregate. Construction equipment shall not operate directly on the geotextile fabric. A minimum of 4" of aggregate base material must be placed on the geotextile prior to the movement of construction equipment and turning movements must be carefully monitored. All ruts that develop during construction shall be filled with additional aggregate base material and compacted to the specified density at no additional cost to the City. If placement of the backfill causes damage to the geotextile, the damaged area shall be repaired as described in Section 3.1.2.A at no additional cost to the City.

### 3.2. GEOGRIDS

#### 3.2.1. STORAGE AND HANDLING

Geogrids shall be stored above -20° F and be protected from prolonged periods of direct exposure to sunlight. The Contractor shall prevent excessive mud, wet cement, epoxy or similar material that may affix themselves to the gridwork from coming in contact with the Geogrid.

#### 3.2.2. CONSTRUCTION SEQUENCE

##### A. *Paving Grade Reinforcement*

The geogrid shall be laid out smooth without wrinkles or folds on the prepared subgrade in the direction of the construction traffic. Adjacent geogrid rolls shall be overlapped a minimum of 1.0 foot, ends of rolls shall be overlapped 3 feet. On curves, the material may be cut to conform to the curves. The overlap shall be in the direction of construction and shall be held in place by staples, pins or aggregate piles. Damaged areas shall be repaired by overlaying the area with sufficient material to overlap on all edges by at least two feet.

The aggregate base material shall be placed by end dumping onto the geogrid from the edge or over previously placed base aggregate. Construction equipment will not be allowed directly on the geotextile fabric. A minimum of 4" of aggregate must be placed on the geogrid prior to the movement of construction equipment and turning movements must be carefully monitored. Any ruts occurring during construction shall be filled with additional gravel aggregate and compacted to the specified density. If placement of the backfill causes damage to the geogrid, the damaged area shall be repaired as described above.

##### B. *Slope Reinforcement*

1. Contractor shall provide an installation plan detailing his intended operation.
2. Fill placement over geogrid

- a. Backfill shall be placed in minimum 6-inch lifts compacted to 95% standard proctor density.
- b. Backfill shall be placed in a manner that minimizes the development of wrinkles and/or movement in the geogrid.
- c. Construction equipment shall not operate directly on geogrid. A minimum of twelve inches of fill shall be placed prior to equipment operating on top of geogrid.

3. Splices

Ends of geogrid rolls shall be spliced by the use of an extruded rod or bar of the same material as the geogrid, supplied by the geogrid supplier. Overlapping ends of geogrid rolls shall not be allowed in lieu of a mechanical connection.



**PART 4**  
**GUARANTEE, MEASUREMENT & PAYMENT**

4.1. GUARANTEE

The guarantee shall be per the contract.

4.2. MEASUREMENT AND PAYMENT

*4.2.1. PAVING GRADE REINFORCEMENT*

Payment for the geotextile or geogrid will be made on a square yard basis for the area covered. No allowance will be made for overlaps, repairs, drainage trenches or cutoff trenches. Area covered shall be from 1 foot behind the curb to 1 foot behind the opposite curb. Payment shall be considered full compensation for all labor, materials, equipment and other items necessary and incidental to completion of the work.

*4.2.2. SLOPE REINFORCEMENT*

Payment will be made on a square yard basis for the amount of geogrid installed, for the various types.

*4.2.3. OTHER COSTS*

All other costs for work necessary to properly complete the work specified herein shall not be bid items; the costs shall be charged to other items unless a bid item is specifically included on the bid sheet.

**CITY OF FARGO SPECIFICATIONS  
AGGREGATE BASES**

**PART 1  
DESCRIPTION OF WORK**

The work to be done under this section of the Specifications and the accompanying plans consists of all labor, material, accessories, and equipment necessary to install aggregate base material for the construction of certain streets, avenues or alleys in the City of Fargo.

**PART 2**  
**MATERIALS**

2.1. AGGREGATE

Material for aggregate base shall conform to the requirements of ND Class 5 Aggregate, and shall consist of sound, durable particles of gravel or sand, free of sod, roots, and other organic matter. The physical characteristics and quality of the materials shall be approved by the Engineer.

When the aggregate does not meet the gradation specified for all required samples, a reduction in the contract unit price will be made for such material in accordance with the acceptance requirements for Aggregate Base outlined in the current version of the NDDOT Standard Specifications for Road and Bridge Construction.

2.2. ASPHALT MILLINGS USED FOR BASE

When allowed by the Engineer, asphalt millings may be blended with ND Class 5 aggregate to produce a base material. The base material shall be made by uniformly blending asphalt millings with Class 5 aggregate. The percentage of recycled asphalt millings shall not exceed 50% of the blended base material. The maximum particle size of the base material shall be 1 inch, and the maximum percent passing the No. 200 sieve shall be 10%.

2.3. CRUSHED CONCRETE USED FOR BASE

When allowed by the Engineer, clean crushed concrete may totally replace or be uniformly blended with ND Class 5 aggregate to produce the base material. The gradation shall be as follows:

- 100% passing the 1.5" sieve.
- 35% to 85% passing the #4 sieve.
- 16% to 50% passing the #30 sieve.
- Max. 12% passing the #200 sieve.

2.4. EQUIPMENT

All equipment shall be kept in satisfactory repair at all times and shall meet the approval of the Engineer.

*2.4.1. SCALES*

When a tonnage pay item is specified, the scales used shall be of the platform type sensitive to a weight of twenty (20) pounds and shall have the capacity to weigh the maximum load. The scales shall be approved and calibrated by the state in which it is located and proof of such calibration furnished to the Engineer upon his request.

*2.4.2. OTHER EQUIPMENT*

Rollers, water hauling equipment, and material hauling equipment shall conform to Sections 151 through 153 of the NDDOT Standard Specifications for Road and Bridge Construction.

**PART 3**  
**CONSTRUCTION**

3.1. PREPARATION OF THE EXISTING SUBGRADE

Excavation and subgrade preparation shall meet the requirements of Section #2000 of these Specifications. Any unstable areas shall be repaired prior to placing aggregate base. Geotextiles and/or Geogrids shall meet the requirements of Section #2050 of these Specifications.

3.2. MATERIAL PLACEMENT AND COMPACTION

Where geotextiles or geogrids are used, small dozer equipment or front-end loaders with low ground pressures shall be used to spread the material.

Water shall be applied to the base material during the mixing and spreading operations so that at the time of compaction the moisture content is not less than 4 percent of the dry weight.

All compaction equipment shall be operated to produce uniform density throughout the entire section. Base material shall be compacted simultaneously with laydown operations until, in the sole opinion of the Engineer, a tightly bound surface is achieved and there is no further evidence of consolidation, rutting, or displacement under rolling operation. The Engineer may elect to perform density tests as needed to assist inspection. The test results must indicate that the aggregate base has been compacted to not less than 95% of Standard Proctor Density in order to be acceptable.

3.3. SURFACE TOLERANCE

Final grade shall be within plus or minus 1/4" (0.02') of specified grade.

**PART 4**  
**GUARANTEE, MEASUREMENT & PAYMENT**

4.1. GUARANTEE

The guarantee shall be per the contract.

4.2. MEASUREMENT AND PAYMENT

Payment for aggregate base shall be full compensation for all labor, material, equipment and miscellaneous items necessary for constructing the base in place.

*4.2.1. AGGREGATE BASE*

Aggregate base shall be paid for by the contract unit price per square yard for the corresponding Gravel Base bid item. The pay area shall be the same as for subgrade preparation in Section 2000 of these Specifications. Payment shall include full compensation for all base material placed within the pay limits, including material required in medians and/or for the installation of drain tile and any other material. Any additional base material required to ensure a stable base for paving equipment shall be at the Contractor's cost.

When called for in the special provisions and/or tonnage bid items are provided on the bid sheet, the Contractor shall provide the Engineer in the field at the point of delivery with computer-generated haul tickets for each load showing the scaled weight of the material incorporated into the project. If tickets are not delivered in this manner, the material will not be eligible for payment unless the Engineer has given prior written approval for some other ticket delivery method.

*4.2.2. OTHER COSTS*

All other costs for work necessary to properly complete the work specified herein shall not be bid items; the costs shall be charged to other items unless a bid item is specifically included on the bid sheet.

**CITY OF FARGO SPECIFICATIONS  
CONCRETE PAVING AND CURBS & GUTTERS**

**PART 1  
DESCRIPTION OF WORK**

The work to be done under this section of the Specifications and the accompanying plans consists of furnishing all labor, material, accessories, and plant necessary to complete the concrete curb and gutter and/or concrete paving of certain streets, avenues or alleys in the City of Fargo.

This item includes excavation, filling, and subgrade preparation in accordance with Section #2000. This item shall also include the furnishing and placing reinforcing steel, curb and gutter, valley gutters, furnishing and setting headers, constructing the type of paving designated, setting castings or valve boxes to grade, and all other work as may be necessary to properly complete the work in accordance with these Specifications and the accompanying plans.

**PART 2**  
**MATERIALS**

2.1. CEMENT

Cement shall meet the current specifications of ASTM. The cement shall be an approved and established brand of Portland Cement Type I or II meeting the requirements of ASTM C-150. Different brands of cement, or the same brand of cement from different mills, shall not be mixed during use without permission of the Engineer. Cement shall be stored in a suitable manner to prevent moisture damage; cement which is partially set or which contains lumps or cakes shall be rejected.

2.2. AGGREGATES

Aggregate for slip-form and alley paving mixes shall generally be provided with gradations considered well-graded by specification as determined by the most current NDDOT Specification for Well-Graded Aggregates for concrete. Optimization techniques will be used to prepare the final aggregate gradations for workability and coarseness factor considerations. Fine and coarse aggregates for all other mixes shall conform to the requirements of ASTM C33 for Concrete Aggregates and meet the following requirements:

A. FINE AGGREGATES:

<u>Sieve Designation (Square Openings)</u>	<u>Percentage by Weight Passing Sieves</u>
3/8 Inch	100%
No. 4	95-100%
No. 16	45-80%
No. 50	10-30%
No. 100	0-10%
No 200	0-3%

The maximum limits of deleterious material shall not exceed the limits stated in ASTM C33-93. Shale content shall be less than 1 %.



## B. COARSE AGGREGATES:

<u>Sieve Designation (Square Openings)</u>	<u>Percentage by Weight Passing Sieves</u>
1 1/2 Inch	100%
1 Inch	95-100%
1/2 Inch	25-65%
3/8 Inch	15-55%
No. 4	0-10%
No. 8	0-5%

The maximum limits of deleterious material shall not exceed the limits stated in ASTM C33-93, Class 4S; the total of all deleterious substances, excluding No. 200 material, shall not exceed 2.3% by weight. Shale content shall be less than 1 %. The aggregate shall show a loss of not more than 35% when tested in accordance with ASTM C131.

Crushed hydraulic cement concrete will not be allowed.

2.3. WATER

Water for concrete shall be clean, free from oil, acid, alkali, and vegetable substances.

2.4. ADMIXTURES*2.4.1. AIR ENTRAINMENT*

An air entrainment admixture or air entrained cement is to be used. Entrained air content shall be targeted for 6% and will be between 5% and 8% as measured at the point of placement. Air entrainment admixtures shall conform to ASTM C-260 standards; air-entraining cement shall conform to ASTM C226.

*2.4.2. ACCELERATORS AND OTHER ADMIXTURES*

A water reducing concrete admixture shall be used in the concrete mix. All admixtures shall meet ASTM C494. Accelerators and water reducing admixtures shall be non-chloride type.

### *2.4.3. FLY ASH*

Fly ash shall meet the requirements of AASHTO M-295 for Portland Cement Concrete. Fly Ash will be allowed as a cement replacement on a 1:1 ratio, up to a maximum of 30% by weight. Fly ash content of mixes will be reduced to a maximum of 20% replacement of cement in cold weather concrete conditions. Cold weather exists when the air temperature has fallen to, or is expected to fall below 40°F (4°C) during the protection period, which is defined as the time required to prevent concrete from being affected by exposure to cold weather. All fast-track concrete mixes will include at least 20% direct replacement of cement with fly ash.

### *2.5. EPOXY RESIN ADHESIVE*

Epoxy resin shall meet or exceed the requirements of AASHTO M235 Type IV, Grade III.

### *2.6. REINFORCEMENT STEEL, DOWELS OR TIE BARS*

#### *2.6.1. PLAIN OR DEFORMED STEEL BARS*

Plain or deformed steel bars shall comply with ASTM A615 or ASTM A616 standards. Bars shall be free of excess rust, scale or other substance that may prevent bonding of the concrete to the reinforcement. All intersections of the longitudinal and transverse bars shall be securely wired, clipped or welded together to prevent displacement during handling and construction operations.

#### *2.6.2. DOWEL AND TIE BARS*

Deformed steel bars meeting the Specifications for bar reinforcement shall be used for the tie bars joining slabs together across longitudinal joints or joining slabs to the curb and gutter section. Dowel bars across transverse joints shall be epoxy coated smooth round bars meeting the Specifications for bar reinforcing. Plate dowels shall be of trapezoidal shape and epoxy coated. All dowels shall be greased or coated for debonding as indicated below. All tie bars used for the longitudinal joints or joining slabs to the curb and gutter section shall be epoxy coated and meet the requirements of AASHTO M-284. The epoxy coating shall be in accordance with AASHTO M284/M.

All epoxy coated bars shall be protected from the sun's rays with tarps or other means if they are to be subjected to the sun's rays for more than 180 days. Exposure for periods

longer than 180 days will result in the product being rejected from use on City projects. Bars carried over as excess from previous year's construction shall not be used on any project unless documentation of protection from the sun is given to the Engineer. Bars showing rust through the coating shall be rejected for use on a project. Epoxy coatings shall be 8 to 12 mils in thickness.

Bondbreaker coatings of dowel bars shall include any effective coatings as approved by the NDDOT, and may include Contractor applied grease or form oil spray applications and factory applied Tectyl-506.

## 2.7. JOINT MATERIAL

### *2.7.1. EXPANSION JOINTS*

If expansion or isolation joints will be required, they shall be as indicated in the diagrams. Expansion/Isolation joint material shall conform to ASTM D-1751. Joint material shall be 1-inch in thickness, 1/2 inch less in height than the pavement depth. It shall extend the full width of the pavement slab and curb, and any concrete at the ends when the forms are removed shall be chipped away. The dowel support shall securely and rigidly hold the dowel bars and premolded filler in correct position during the paving operation. All expansion/Isolation joint faces shall be cleaned by sandblasting and sealed with silicone sealant to produce a slightly concave surface approximately 1/4 inch below the concrete surface.

The expansion joint dowel bar assembly shall be of a type as manufactured by Dayton Superior, Wady Industries, Construction Materials, Inc., Laclede Steel Company, the Bethlehem Steel Company, the American Steel and Wire Company, or approved equal. The entire expansion joint assembly shall be of a type approved by the Engineer.

### *2.7.2. POURED JOINT FILLER*

The material for filling poured expansion and contraction joints and cracks shall be hot poured elastic type and shall conform to the requirements of ASTM D-6690. The material shall be composed of a homogeneous blend of virgin polymers, plasticizers, special fillers and asphalt compounded specifically for the sealing of cracks in asphalt or concrete pavement. Ground cured rubber scrap shall not be used. Meadows Safe-Seal 3405 is an approved substitute for the hot pour material.

*2.7.3. SILICONE JOINT SEALANT*

The sealant shall be a Low Modulus Silicone Sealant meeting the requirements of the NDDOT Specifications, Section 826.02.B.1. Self-leveling silicone sealants will not be allowed.

2.8. CURING COMPOUNDS

All curing compounds shall be applied in accordance with the manufacturer's recommendations.

*2.8.1. MAINLINE (INCLUDING CURB & GUTTER SECTION) AND ALLEY PAVING*

Linseed oil based or poly-alpha-methylstyrene liquid curing compound, white pigmented conforming to the requirements of AASHTO M 148 Type 2, Class B.

*2.8.2. CURB & GUTTER ADJOINING ASPHALT PAVEMENT*

White pigmented conforming to the requirements of AASHTO M 148 Type 2.

2.9. PROPORTIONS

One cubic yard of mixed concrete in place shall contain not less than 564 lbs. minimum of cementitious materials. The water-cement ratio shall not exceed 0.40 for slip-formed pavement and 0.42 for hand-placed pavement mix. The slump shall not exceed four (4) inches. Minimum 28-day compressive strength shall be 4,000 p.s.i. Entrained air content shall be targeted for 6% and will be between 5% and 8%.

Mixes shall use optimized aggregate proportioning to meet well-graded mix specifications of the NDDOT for all slip-form concrete pavements. Hand-placed concrete pavements shall also have optimized aggregate gradations or meet NDDOT AE-3 mix criteria.

2.10. FAST-TRACK CONCRETE

When Fast-track Concrete Mixes are specified, the Contractor shall use the following criteria:

1. Cements will be Type I or II with a maximum of 564 lbs. total cementitious content including a minimum of 20% replacement of cement with fly ash. Water-cement ratios will be as limited above in Section 2.8.

2. Fast-track mixes will have optimized aggregate, will use non-chloride accelerators for early strength, and may use hydration stabilizers to preserve workability en-route to the project.
3. Contractor shall provide environment to ensure that mixes will attain a field strength of either 400 psi flexural strength or 2500 psi compressive strength in 24 hours. At no time may concrete exceed 150° F in temperature while under blankets or other protection devices, nor fall below 60° F during the 24 hour period.

#### 2.11. PLANT CERTIFICATION

All plants supplying concrete to a paving project shall be certified by an approved plant certification program including that provided by the National Ready Mix Concrete Association, MNDOT or NDDOT in the current construction season.)

#### 2.12. MIXING

Concrete shall be mixed in a rotary batch mixer of a type acceptable to the Engineer. The volume of the mixed material for each batch shall not exceed the manufacturers rated capacity of the mixer. The batch material shall be delivered to the mixer accurately measured to the desired proportions and shall be continuously mixed for not less than one and one-half minutes after all materials including water are in the mixer, during which time the mixer shall rotate at the speed recommended by its manufacturer.

In lieu of job-site or batch mixing, ready-mixed concrete, meeting the requirements specified herein and all applicable requirements of ASTM C94 may be used. The size of the batch shall not exceed the manufacturer's rated capacity as shown on a metal rating plate that shall be attached in a prominent place on the truck mixer. When mixing, the drum shall rotate at a mixing speed for not less than 60 revolutions and not more than 300 revolutions. The drum shall be completely emptied before receiving the material for the succeeding batch.

The concrete shall be completely discharged within 90 minutes after the introduction of the mixing water to the dry materials when ambient temperatures are less than or equal to 80 degrees. This time is reduced to 60 minutes when temperatures exceed 80°F. Mix temperatures between batching and placement shall not exceed 90 degrees F. Observations and adjustments to slump shall be made at the time of preparation for dumping. Once dumping of mix is started, retempering of mortar or concrete is not allowed.

### 2.13. FORMS

Forms shall be metal, made of shaped steel, with sections that interlock and are at least 10 feet in length. The forms shall be of the same thickness as the concrete to be placed against them and shall have a base width of at least 2/3 their height. They shall have at least 3 stake pockets for every 10 feet of length and the bracing and support must be able to withstand the pressure of the concrete and weight and thrust of the machinery operating on the forms. Forms shall be set upon the compacted subgrade at to exact line and grade for a distance of at least 300 feet in advance of the concrete placing operation. Metal forms shall be oiled or coated with soft soap or whitewash before depositing the concrete against them. Forms shall be mortar and dirt free and shall be checked with a 10-foot straightedge and any variation in excess of 1/8 inch shall be corrected.

Approved flexible or curved forms of proper radius shall be used on curves having a radius 150 feet or less. Straight forms longer than 10 feet shall not be used on any curved line unless approved by the Engineer.

If the pavement is being placed contiguous to previously finished pavement or curb and gutter, such finished pavement or curb and gutter may be made to serve as a side form if found to be suitable in the opinion of the Engineer.

### 2.14. SLIPFORM PAVING EQUIPMENT

All equipment shall be self propelled, and designed for the specific purpose of placing, consolidating, and finishing the concrete pavement to grade and cross-section in one complete pass without the use of side forms. The paver shall vibrate or tamp the concrete for the full width and depth of the layer being placed.

### 2.15. CONCRETE FINISHING MACHINES

The finishing machine shall be adjustable to the specified crown and elevation to maintain the required cover over the reinforcing steel. The machines shall be capable of striking-off and finishing the concrete and compaction shall either be done by the same machine or in a separate operation. The screed shall extend the full width of the slab. All finishing equipment shall be kept in good repair and their use subject to the approval of the Engineer.

2.16. AUXILIARY FINISHING EQUIPMENT AND MATERIAL

The Contractor shall provide the following auxiliary equipment:

- A. *FOOTBRIDGE*  
A footbridge shall be provided so designed that it can be readily transported from place to place and span the width of the slab.
- B. *STRAIGHT EDGE*  
Two or more ten (10) foot straight edges of an approved type shall be used. Extra blades shall be provided and used when previously used edges become wavy and warped.
- C. *FLOATS*  
Approved long-handled floats, each having a blade at least 3 feet in length and 6 inches in width.
- D. *MASTER STRAIGHT-EDGE*  
All straight edges shall be tested by the master straightedge before being used and frequently during their use.
- E. *BROOMS*  
Brooms shall be of an approved push type not less than 18 inches long, from good quality bass or bassine fiber not more than five (5) inches in length. The handle shall be at least one foot longer than one-half the pavement width and shall be readily adjustable.

2.17. SUBMITTALS

At the Engineer's discretion, the Contractor may be required to submit representative samples of the materials he proposes to use prior to the delivery of the materials to the site of the work.

On all projects, the Contractor shall provide the following to the Engineer at least 7 days prior to beginning any concrete placement or paving operations:

- A. *PROJECT MIX DESIGN*  
The Contractor shall develop a trial mix design.

*B. FLY ASH CERTIFICATION*

An original certificate of compliance showing the following information:

1. Project number and name of Contractor
2. Fly ash source by name of company and location of plant
3. Quantity of fly ash in shipment
4. Date of shipment
5. Statement that fly ash meets all requirements of the Specifications

*C. JOINT FILLER/SEALER CERTIFICATE OF COMPLIANCE*

The type of backer rod shall be shown, along with an original certificate of compliance showing the following information for each type of joint filler/sealer to be used on a project, as applicable:

1. Project number and name of Contractor
2. Name of the manufacturer and type of joint filler/sealer
3. The manufacturer's batch and lot number
4. The trade name of the material
5. The weight, pouring temperature, and safe heating temperature
6. Statement that materials meet all requirements of the Specifications

*D. CURING COMPOUND CERTIFICATE OF COMPLIANCE*

An original certificate of compliance showing the following information:

1. Project number and name of Contractor
2. Name of the manufacturer and type curing compound
3. The trade name of the material
4. Statement that materials meet all requirements of the Specifications



**PART 3**  
**CONSTRUCTION**

3.1. EXCAVATION AND SUBGRADE PREPARATION

Excavation and subgrade preparation shall meet the requirements of Section #2000.

3.2. PLACING REINFORCEMENT

Reinforcement, when specified, shall be installed according to the details as shown in the typical section. Reinforcement rod shall be overlapped a minimum of 40 diameters and securely tied. The reinforcement shall be positioned on approved supports or it may be inserted in the plastic concrete by approved mechanical devices after the concrete has been spread, struck off, and consolidated to its full depth.

Dowel bars, when specified, shall be placed in close alignment, both horizontally and vertically, with the direction of the anticipated thermal movement of the slab. Tolerance for horizontal and vertical rotational alignment: 1/8 inch per foot. Tolerance for longitudinal shift: 1.5". Tolerance for vertical placement: 1/4" above, 1/2" below height specified in Chart 1 shown on the Transverse Contraction Joints Detail, except for 7" pavement which shall be mid-slab.

When drilling holes for placement of dowel bars and tie bars, an epoxy resin adhesive shall be used to anchor the bars in the drilled hole. The diameter of the drilled hole shall be as recommended by the epoxy manufacturer. In the absence of recommendations from the manufacturer, holes shall be drilled 1/8 to 1/4 inch larger than the diameter of the dowel bars and tie bars. The drilled holes shall be blown out with compressed air using a device that will reach to the back of the hole to ensure all debris and/or loose material is removed prior to epoxy injection.

Prior to insertion of the bars, drilled holes shall be filled with epoxy resin 1/3 to 1/2 full, or as recommended by the manufacturer. Each bar shall be rotated during installation to eliminate voids and to ensure complete bonding occurs. Bar insertion by the dipping method will not be allowed.

3.3. PLACING CONCRETE

All concrete shall be placed with formwork unless placed by a curb machine or mechanical paver. Curb and gutter may be installed integral with the concrete pavement except at curb radii and one full panel height on each side of inlet castings not located in a radius, where it shall be installed separate. After mixing, the concrete shall be handled rapidly and the successive batches deposited

in a continuous operation until individual sections are completed. The concrete shall be placed so segregation and unnecessary rehandling is avoided. Immediately prior to placing the concrete, the inside of the forms shall be wetted and the aggregate base moistened with water. The forms shall be filled and concrete brought to the established grade. Trucks hauling concrete shall not back over reinforcing or over previously deposited concrete. Ruts exceeding ½ inch in depth shall be filled with granular material prior to the placing of concrete. Concrete shall not be placed on a frozen subgrade or base.

The mixed concrete shall be deposited on the subgrade to the required depth and for a width not exceeding the direct reach of the mixer boom, in successive batches and in a continuous operation without the use of intermediate forms or bulkheads between joints. If concrete placement is temporarily interrupted, the unfinished face of the concrete shall be covered with wet burlap or plastic sheeting. When placement operations are resumed, the concrete shall be broken down and thoroughly consolidated with the fresh concrete. If the elapsed time between placement loads of concrete exceeds 45 minutes, a transverse construction joint shall be installed. While being placed, the concrete shall be vibrated with spud type vibrators or a vibrating screed so that the formation of voids or honeycomb is prevented. The concrete shall be especially well vibrated against the forms and along fixed structures.

### *3.3.1. COLD WEATHER POURING*

Concrete shall not be deposited when it appears likely that the air temperature may fall below 35° F during the pouring or within 24 hours unless preparations are made and precautions taken to prevent any damage to the concrete from the low temperature. Any concrete damaged by freezing shall be replaced by the Contractor at his own expense. Temperature of the concrete when deposited in the forms shall be between 55° and 90 ° F and maintained at a minimum of 40° F for at least 5 days after placing, or until the concrete attains a compressive strength of 3000 psi. If the temperature is expected to drop below 35° F, prior to placement of concrete, the Contractor shall submit a detailed plan of how the concrete's temperature will be maintained above 40° F. Concrete shall not be placed on a frozen subgrade or base.

A calcium chloride admixture shall not be used. Non-chloride accelerators shall be used. Accelerators will not be considered as an "anti-freeze agent".

### 3.4. JOINTS AND SAWING

Joints in concrete pavement shall be of the design specified and shall be constructed at the spacing and locations shown on the plans. Where a specific jointing layout is not provided, jointing shall be per the standard detail in these Specifications. The contractor shall establish the joint locations in the field from the plans or standard details. All joints shall be sawed along a true and straight line established by the Contractor and shall not deviate at any point by more than 1/2 inch from the established line.

#### *3.4.1. TRANSVERSE CONTRACTION JOINTS AND SAWING*

The location of each transverse joint shall be marked in a manner satisfactory to the Engineer, prior to placement of the concrete and, in the case of joints that are to be sawed, the markings shall be transferred to the fresh concrete as soon as the final finishing operations have been completed. All contraction joints shall be sawed to a sufficient depth to control cracking, but in no case to a depth less than 1/4 of the thickness of the pavement plus 1/4 inch. Transverse joints constructed in the pavement shall be extended through the integral or separate curb. The Contractor shall be responsible for sawing to a depth that will prevent uncontrolled cracking. A sufficient number of saw cuts shall be made as soon as possible to relieve the contraction joint tension in the slab. Remaining saw cuts must be made within 48 hours after pouring.

The initial sawing shall be accomplished as soon as the condition of the concrete will permit without raveling and before random cracking occurs. The sequence of initial sawing shall be at the Contractor's option. The sawing shall be immediately delayed if any raveling occurs. Water under nozzle pressure shall be used to remove the sawing residue from each joint and the pavement surface immediately after completing the sawing of that joint. Widening of the joints to full width as per dimensions shown on the jointing/sealing detail shall not be performed until the concrete has cured for at least 24 hours and shall be delayed longer when the sawing causes joint raveling.

The early entry dry saw "Soff-Cut" method of sawing will only be allowed with the Engineer's approval for the initial saw-cutting. Concrete pavement in which uncontrolled cracks occur shall be removed and replaced at the Contractor's expense. The work shall include the complete removal and replacement of a quantity of pavement, to include dowel bar assemblies when applicable, as is determined necessary for acceptance of the pavement by the Engineer. Any/all damage occurring during the removal and replacement process shall be restored at the Contractor's expense (including but not

limited to base or subgrade). All removal and replacement work shall be in accordance with the requirements of these Specifications.

#### *3.4.2. TRANSVERSE EXPANSION JOINTS*

Expansion joints shall be spaced as shown on the plans and shall be of the preformed type and shall extend entirely through the depth and width of the pavement and through all integral curbs. No concrete shall be left above the expansion material or across the joint, but shall be cut away after the forms are removed.

Dowel bars shall be installed for load transfer across the joint. They shall be held in place midway across the joint, parallel to both the surface and the centerline of the slab by an approved supporting device. The “free” end of the dowel shall be coated with an approved lubricant and covered with an approved metal or plastic dowel cap or sleeve. The preformed filler material shall be accurately pre-punched to fit snugly around the dowel bars.

The expansion material and dowel assembly shall be accurately and firmly staked to the subgrade. The top edge of the filler shall be set 1/2 inch below the pavement surface. During the placing of the concrete, the top edge of the filler shall be protected by a removable channel cap. After the concrete has been placed and finished, the cap shall be removed and the joint edged to the specified radius. All expansion/Isolation joints shall be cleaned by sandblasting and sealed with silicone sealant to produce a slightly concave surface approximately 1/4 inch below the concrete surface.

Before the pavement is opened to traffic, the joint shall be cleaned so that there is a clear space of the specified width for the full depth and width of the pavement. It shall then be filled with joint filler which when cooled shall become flush with the surface of the pavement. Any sealant material on the surface of the pavement shall be removed at the Contractor’s expense.

#### *3.4.3. TRANSVERSE CONSTRUCTION JOINTS*

Transverse construction joints shall be constructed whenever the placing of the concrete is suspended for more than 45 minutes. When the work is suspended near the proper location for an expansion joint, the expansion joint shall be installed in the manner previously specified, except that the concrete shall only be placed on one side of the header, when work is resumed it shall be placed on the other side.

When work is suspended at other locations, a contraction joint shall be formed by securely staking in place at right angles to the subgrade and centerline of the pavement, a bulkhead of wood or metal cut to the cross-section of the pavement and then depositing concrete against it. Before the work is resumed, the bulkhead shall be removed and concrete placed against the face of the older concrete.

Transverse construction joints shall only be constructed at planned transverse joint locations.

Dowel bars shall be installed for load transfer across the joint. The Dowel bars shall be either installed with the construction joint or later drilled in place. If installed with construction joint they shall be held in place midway across the joint, parallel to both the surface and the centerline of the slab by a dowel splicer basket assembly, self supported dowel sleeve, or other supporting device approved by the Engineer. The dowel bars shall be installed within the tolerances specified above for placing reinforcement. One end of the dowel shall be painted or coated with an approved lubricant.

#### *3.4.4. LONGITUDINAL JOINTS*

The longitudinal joint between adjoining, separately constructed pavement shall be as constructed as shown on the plans. Tie bars shall be as shown in the detail and may be bent at right angles against the form of the first lane constructed and straightened into final position before the adjacent concrete is placed. Bars may be placed or inserted through small accurately positioned holes or by other approved methods. Tie bars or tie bar baskets shall be placed so that they are not within 12 inches of the intersection of the longitudinal joint and the transverse joint.

If uncontrolled cracking occurs, the concrete pavement shall be completely removed to the nearest planned longitudinal and transverse joints. The removal and replacement method shall be approved by Engineer and at the Contractor's sole expense.

#### 3.5. PAVEMENT FINISHING

Strike-off and compaction shall be done by both vibrating and screeding processes. Separate power machines may be used for each process or both processes may be combined in the same machine, provided controls exist enabling the operator to apply either operation separately or both combined.

When weather conditions cause rapid drying of the pavement surface a fine mist or fog spray applied to the concrete surface shall be permitted only if approved by the Engineer – using any other method to apply water to the concrete surface will not be permitted and will result in non-payment, replacement, and/or repair of the wetted area as determined by the Engineer.

A. Formwork

Forms shall be left in place for at least 15 hours after placing the concrete, and the method of removing them shall not damage or mar the concrete.

B. Straight Edge

The finished surface of the pavement must conform to the grade, alignment, and contour shown on the plans. Immediately following the floating operation, the Contractor shall test the slab surface for trueness with a 10-foot straightedge. The straightedge shall be placed parallel to the pavement centerline and be passed over the slab to reveal any high areas or depressions. The high areas or depressions shall be cut or filled as necessary with the long handled floats and the area checked again with the straightedge. Successive advances of the straightedge shall overlap by 1/2 the length of the straightedge. The entire surface shall be checked until all variations in excess of 1/8 inch in 10 feet have been eliminated. Special care shall be taken at all headers to ensure this variation is held to a minimum.

### 3.6. CURB FINISHING

No grout shall be used to finish the curb. After the concrete is poured into the forms, it shall be puddled and spaded so as to ensure a through, dense mixture, eliminate air pockets, and create uniform and smooth sides.

When weather conditions cause rapid drying of the pavement surface a fine mist or fog spray applied to the concrete surface shall be permitted only if approved by the Engineer – using any other method to apply water to the concrete surface will not be permitted and will result in non-payment, replacement, and/or repair of the wetted area as determined by the Engineer.

Before the curb concrete has thoroughly set, and while the concrete is still green, the forms shall be removed and the front and top side finished with a float or steel trowel to make a uniform finished surface.

A.     ROUNDING CORNERS

Whenever corners are to be rounded, special steel trowels shall be used while the concrete is still workable and the corners constructed to the dimensions herein specified. For combined curb and gutter, the top and side of the curb and gutter may be finished by means of a special shaped trowel or by a curb-and-gutter machine which shapes the entire surface in accordance with the specified dimensions. This trowel shall be used immediately upon removing the front form while the concrete is still workable but firm enough to stand up.

B.     SMOOTHNESS

The top and face of the curb and also the top of the apron on combined curb and gutter must be finished true to line and grade without any irregularities of surface noticeable to the eye. The gutter shall not hold water to a depth of more than 1/4 inch, nor shall any portion of the surface or face of the curb or gutter section depart from more than 1/4 of an inch from a straight edge ten (10) feet in length, placed on the curb parallel to the center line of the street not shall any part of the exposed surface present a wavy appearance.

3.7. FINAL SURFACE FINISH

The edges of the pavement shall be left smooth and true to line, and finished, at about the time the concrete takes its initial set.

After surface irregularities have been removed and before the concrete attains an initial set, the pavement shall be uniformly textured using a seamless strip of artificial grass, or by brooming.

Artificial grass drags or a broom pulled longitudinally in a line parallel to the slab centerline, shall be the texturing method, and shall be maintained in good repair. The texturing material shall apply a uniform texture with 1/16 to 1/8 inch deep striations. The width of the texturing material shall be in full contact over the full width of the pavement. The texturing material shall be cleaned as often as necessary to remove hardened particles or debris that would otherwise scar the surface.

The texturing material being pulled longitudinally shall be mounted to a self-propelled bridge, operated off of the paving string-line, and shall not deviate at any point by more than 1/2 inch from the established alignment.

With formed paving only, brooms shall be drawn across the surface at right angles to the centerline of the pavement, with the stroke of the broom slightly overlapping adjacent strokes. The brooming operation shall apply a uniform texture with 1/16 to 1/8 inch deep striations. Brooms shall be washed and dried at frequent intervals during the day. Any long or coarse bristles that may cause surface irregularities shall be trimmed or cut out, and any brooms that have become worn out shall be discarded.

Upon completion of the final finishing the surface texture shall be uniform in appearance and free of surface water, rough or porous spots, irregularities, depressions, and other objectionable features.

### 3.8. CURING AND PROTECTION

Normal Pavement: As soon as the concrete has been textured, the Contractor shall start curing operations. The finished surface shall be sprayed with an approved curing agent on all exposed faces. Sufficient curing compound shall be applied at a rate of approximately 200 SF/gal to ensure a coating as white as a sheet of paper. In lieu of curing agent, the concrete may be cured by wet burlap or other methods approved by the Engineer. When wet burlap or plastic film is used for curing, the curing period shall be at least 5 days. The concrete surface must not be pitted from or damaged from application of water or incidental rain. The Contractor shall protect all concrete from weather conditions, traffic damage, or any other causes occurring prior to its final acceptance. Any damaged section shall be repaired at the Contractor's expense.

Colored Pavement: Colored pavement shall be cured with an approved clear curing compound generally defined as a dissipating cure or a wax based cure matching the color of the decorative concrete. Curing procedures should generally follow the guidelines of the color admixture supplier for the concrete in the pavement.

Timing of Curing Compound Application: Curing procedures should be undertaken within ½ hour of completion of finishing operations or before the wet sheen on the surface of the concrete disappears, whichever occurs first. Evaporation retarders shall be used for interim protection whenever hot, windy or dry conditions quantified by evaporation rates exceeding 0.2 pounds per square foot per hour exist, and shall be used in accordance with manufacturer's recommendations. Evaporation retarders shall not be used as a finishing aid.



3.9. JOINT FILLING AND SEALING

The Contractor shall not seal joints until they have been inspected and approved by the Engineer. Failure to comply will result in complete removal of the filler/sealer material to allow inspection by the Engineer, at the Contractor's sole expense.

All vertical joint faces shall be cleaned by sandblasting. Oil, asphalt, curing compound, paint, rust, and other foreign materials shall be completely removed. Just before the joints are sealed, the Contractor shall clean the joints with compressed air at a working pressure of at least 90 psi. The joints shall not be sealed when the air temperature is below 40°F.

Backer rod shall be used in all joints to control the depth of the filler/sealer material, achieve the desired shape of the material, and support the material against indentation and sag. The backer rod shall be compatible with the filler/sealer and not subject to the absorption of water. Any joints filled above the specified level shall be corrected by removing and replacing the filler/sealer at the Contractor's sole expense.

Transverse joints constructed in the pavement shall be widened and sealed through the integral or separate curb.

A. HOT POUR

The joint filler shall be forced into the joint with a pressure type applicator capable of filling the joint from the bottom up to a height approximately ¼ inch below the pavement surface, without any overflow or spillage onto the pavement surface. Any excess filler spilled on the pavement surfaces shall be removed at the Contractor's sole expense.

B. SILICONE

Silicone joint sealer may be used in lieu of hot pour elastic filler. The sealant shall be tooled to produce a slightly concave surface approximately ¼ inch below the pavement surface. Self-leveling sealant will not be allowed.

3.10. PROTECTION OF PAVEMENT

The newly-placed concrete shall be protected from traffic by employing watch persons, if necessary, and by the erection and maintenance of barricades, fences, warning signs and lights, pavement bridges, and cross-overs.

When the temperature is expected to fall below 35°F, suitable measures shall be taken to maintain the concrete surface temperature above 40°F for 5 days or until the concrete attains a compressive strength of 3,000 psi. Admixtures for curing or temperature control shall be used only as permitted or directed. The admixtures shall not be considered as a substitute for any specified curing requirement.

Any concrete pavement damaged before final acceptance, including damage by frost action, shall be repaired to the satisfaction of the Engineer or removed and replaced at the Contractor's sole expense.

When bituminous pavement or colored concrete is placed adjacent to PCC pavement, the adjacent PCC pavement shall be protected from spills and smears. Discolored PCC pavement shall be cleaned at the Contractor's sole expense. The PCC pavement shall not be used to stockpile or mix any material unless approved by the Engineer.

### 3.11. PAVEMENT ROUGHNESS AND RIDE QUALITY

This section describes the methods for locating areas of localized roughness, determining the roughness, and provisions for payment and corrective action.

#### A. GENERAL

Except for alley paving, pavement roughness shall be determined and reported in 0.1 mile segments using a profiler on all traffic lanes, including intersections, roundabouts, tapered sections, and turn lane widening segments. Profiles shall be measured by the Contractor in each wheel path per lane and shall be reported as inches/mile in International Roughness Index (IRI) in graph and tabular formats.

Intersections, roundabouts, tapered sections, and turn lane widening segments will not be included in pay deduction calculations. In these areas, only the areas of localized roughness having high points with deviations in excess of 0.3 inches in 25 feet or less will be required to be corrected.

#### B. PROFILER

The Contractor shall furnish a lightweight non-contact profile-measuring device/vehicle capable of measuring IRI in dual wheel paths using a line laser.

The Contractor shall furnish proof of profiler calibration to the Engineer prior to performing profiling operations.

C. MEASURING ROUGHNESS USING A 10' STRAIGHTEDGE

Where directed by the Engineer, pavement shall be measured for roughness using a 10' straightedge and shall meet the following tolerances:

High spots of more than  $\frac{1}{4}$  inch but not exceeding  $\frac{5}{8}$  inch in 10 feet shall be ground with diamond grinding equipment to an elevation where the deviation is less than  $\frac{1}{4}$  inch. When the deviation exceeds  $\frac{5}{8}$  inch, the area shall be ground with diamond grinding equipment to the specified  $\frac{1}{4}$  inch deviation or the pavement shall be removed and replaced at the Contractor's expense. The Contractor shall repair the area as directed by the Engineer, including installing dowel bars at each end of the repair.

D. CORRECTIVE ACTION

Where required by the Engineer as outlined herein, all diamond grinding shall be performed according to section 2900 of these Specifications, except that diamond grinding shall be conducted in increments no smaller than one 11-foot lane and one panel length.

In addition to any areas identified through the use of a 10' straightedge and by using the table below, all localized roughness areas having high points with deviations in excess of 0.3 inches in 25 feet or less shall be ground with diamond grinding equipment at the Contractor's expense. On pavement sections where corrections are necessary, second profiler runs shall be performed to verify that corrections have produced an IRI within acceptable limits, and to determine the pay adjustment, if any.

E. PAY ADJUSTMENT

The Engineer will review the profile data supplied by the Contractor for each individual wheel track to determine areas of localized roughness and the average IRI per lane per segment. Payment shall be adjusted based on the average IRI per lane per segment as follows:

	<b>Payment (Percent of Contract Unit Price)</b>				
	<b>100%</b>	<b>98% or Correct</b>	<b>95% or Correct</b>	<b>80% or Correct</b>	<b>Correct or Remove</b>
<b>PCC Pavements</b>					
<b>&gt; 30 mph</b>	<b>120</b>	<b>121-130</b>	<b>131-140</b>	<b>-----</b>	<b>&gt; 140</b>
<b>All others</b>	<b>130</b>	<b>131-140</b>	<b>141-150</b>	<b>151-160</b>	<b>&gt; 160</b>

Areas measured for roughness using a 10' straightedge shall be paid for at 100% when they are installed or corrected to within the tolerances specified above.

### 3.12. LOCATION OF EXISTING UTILITIES

Existing manholes, gate valves, and stop boxes have been shown to direct the Contractor's attention to their existence. The Contractor is cautioned that not all utilities have been shown and their location is not guaranteed. The Contractor is responsible for determining the exact location of existing utilities that affect the installation of the paving.

### 3.13. CASTING TO GRADE

Floating manhole castings as shown in the standard detail are required on all manholes located in concrete pavement. This item includes all labor, materials and equipment necessary to adjust the various castings to the proper line and grade. Note that wood shims to adjust rings and castings are not allowed. Changes in grade shall be made as follows:

All adjustments, including fine adjustments, shall be made with adjustment rings specified in Section 1500 of these Specifications. All adjustment rings shall be properly sealed in accordance with the manufacturer's recommendations and as follows: For storm sewer manholes/inlets, rings shall either be sealed watertight or be wrapped with nonwoven geotextile fabric, secured around the outside of the rings from three (3) inches below the top of the manhole/inlet structure to the top of the rings, overlapping the frame casting. For sanitary sewer manholes, rings shall be sealed water-tight from the frame casting to the manhole structure. In lieu of the use of an adhesive/sealant, an external mechanical frame-chimney seal may be used for a watertight installation.

Where casting adjustment requirements cannot be met by the use of engineered polymer adjustment rings and upon the Division Engineer's approval, the Contractor shall provide precast

reinforced concrete adjusting rings. For fine adjustments of less than two (2) inches, steel shims shall be used to temporarily support the casting. The castings and rings shall be laid in a full bed of mortar. The rings and structure section shall be cleaned to assure a flat seating surface and the rings shall be installed in alignment with no noticeable offsets. A four (4) inch wide concrete encasement shall be placed around the outside of the rings from three (3) inches below the top of the structure to the frame casting.

Care shall be taken to adjust the casting to the proper grade so the final riding surface is smooth and free of bumps and it conforms to the alignment and grade of the adjoining concrete. Any castings not satisfying these requirements shall be redone to the satisfaction of the Engineer. Castings should be set flush to 1/16 inch below the pavement surface.

The casting to grade item also includes cleaning all construction debris or dirt from the manhole or inlet bottom and installing a wiped mortar finish around the inside circumference of the precast concrete adjusting rings.

#### 3.14. CASTING TO GRADE (BOULEVARD)

This bid item shall be in accordance with Section 1200 or 1500 of these Specifications, as appropriate.

#### 3.15. CURB INLET CASTING TO GRADE

All adjustments, including fine adjustments, shall be made with HDPE adjustment rings as specified in Section 1500 of these Specifications. All adjustment rings shall be properly sealed or wrapped with nonwoven geotextile fabric in accordance with the manufacturer's recommendations.

#### 3.16. GATE VALVES TO GRADE

This item shall include all labor, material, and equipment necessary to raise or lower water gate boxes to the final grade. Care shall be taken to adjust the valve box to the proper grade so the final riding surface is smooth and free of bumps and that it conforms to the grade of the adjoining concrete. The alignment shall be checked to ensure that the box is straight and that the valve is operable. Any valve boxes not satisfying these requirements shall be redone to the satisfaction of the Engineer. Valve boxes should be set within 1/16 inch of the finished pavement surface.

The gate box to grade item also includes cleaning all construction debris or dirt from the box, insuring that the box is straight and undamaged, and insuring that the valve is operable.

### 3.17. TESTING

The Engineer may take samples and make tests to assure that the work is being performed in accordance with these Specifications. The Contractor shall cooperate in the making of such tests to the extent of allowing free access to the work, for the selection of samples.

Samples shall be obtained and tested in accordance with the latest ASTM methods of tests. Testing labs shall supply reports to the Engineer, Contractor, and concrete supplier.

### 3.18. OPENING TO TRAFFIC

Newly constructed pavement shall not be opened to Contractor or public traffic until the concrete has attained a compressive strength of 3,000 psi, as determined by breaking test cylinders cured in the field in a manner that replicates as closely as possible the curing conditions of the pavement. In addition to the strength requirements, the newly constructed concrete pavement shall not be opened to any traffic until all joints have been sealed unless permission is granted by the Engineer. The Contractor shall erect and maintain suitable barricades and lights to protect the pavement from traffic. Any part of the pavement damaged from traffic or other causes occurring prior to the acceptance of the pavement shall be repaired to the satisfaction of the Engineer at the Contractor's sole expense.

The Contractor shall receive written notice from the Engineer to open the pavement to traffic and shall then dispose of all covering material as directed and remove all barricades.

### 3.19. SIDEWALKS AND DRIVEWAYS

The construction of sidewalks, driveways and impressed concrete shall be done in accordance with Section 2300.

**PART 4**  
**GUARANTEE, MEASUREMENT & PAYMENT**

4.1. GUARANTEE

The guarantee shall be per the contract.

4.2. MEASUREMENT AND PAYMENT

Payment for concrete paving and castings and gate valves to grade shall be full compensation for all labor, material, equipment and miscellaneous items necessary for constructing these items in place.

*4.2.1. EXCAVATION AND SUBGRADE PREPARATION*

Paid under Section #2000 contract bid items.

*4.2.2. UNDER-STRENGTH CYLINDERS OR BEAMS*

Payment for PCC specified herein will not be made until the Engineer is satisfied that the material will meet the specified strength requirements. When test cylinders show under-strength PCC, cores shall be taken in the field and tested. The number and location of the cores will be at the discretion of the Engineer. All costs for coring and retesting will be deducted from the Contractor's payment. All PCC found to be under-strength shall be removed and replaced at the Contractor's sole expense.

*4.2.3. CONCRETE PAVEMENT*

Concrete pavement shall be paid for at the unit price bid per square yard. Concrete pavement shall include the area of paving only and does not include the area of the curb or gutter pan.

*4.2.4. CONCRETE CURB AND GUTTER*

Curb and gutter will be measured along the curb face and be paid for at the contract unit price per linear foot. Where integral curb is poured, paving and curb payment will be based on a standard 30" wide curb and gutter section.

*4.2.5. CONCRETE VALLEY GUTTERS*

Valley gutters will be measured and paid for at the unit price bid per square yard.

*4.2.6. CONCRETE SIDEWALKS, DRIVEWAYS, AND IMPRESSIONED CONCRETE*

Sidewalks, driveways, and impressioned concrete shall be in accordance with Section 2300.

*4.2.7. CASTINGS TO GRADE*

This bid item shall include all work to adjust the casting with up to 4 rings, including all sealant, wrap, or chimney seals as specified herein. Adjustments to inlets and manholes located in the pave shall be paid for under the "Casting to Grade – w/Conc" bid item. Adjustments to inlets and manholes located outside the pave shall be paid for under the "Casting to Grade – Blvd" bid item.

*4.2.8. VALVE BOXES TO GRADE*

Adjustments to valve boxes located in the pave shall be paid for under the "GV Box to Grade – w/Conc" bid item. Adjustments to valve boxes located outside the pave shall be paid for under the "GV Box to Grade – Blvd" bid item.

*4.2.9. SMOOTHNESS AND GRINDING*

Payment adjustment will be as specified in Section 3 above for the smoothness requirement designated.

*4.2.10. OTHER COSTS*

All costs of reinforcing steel, curing and protection, jointing and joint filling/sealing, and all other costs of work necessary to properly complete the work specified herein shall not be bid items; the costs shall be charged to other items unless a bid item is included on the bid sheet.



CONCRETE PAVEMENT WIDTH	BACK-TO-BACK WIDTH A	GRAVEL BASE WIDTH B	SLAB THICKNESS C	GRAVEL THICKNESS D	% CROSS SLOPE E	CROSSCROWN HEIGHT BELOW TOP OF CURB		PANEL HEIGHT F	CENTER PANEL WIDTH-G	OUTSIDE PANEL WIDTH-H	ENGINEERING FABRIC
						STD	MNTBLE				
32'	33'	35'	8"	8"	2.35%	1 1/2" BELOW	1/2" ABOVE	12'	8'	8.5'	ENG. FABRIC
36'	37'	39'	8"	8"	2.30%	1" BELOW	1" ABOVE	12'	9'	9.5'	ENG. FABRIC
40'	41'	43'	9"	8"	2.30%	1/2" BELOW	1 1/2" ABOVE	15'	10'	10.5'	ENG. FABRIC
51'	52'	54'	9"	12"	2.30%	1" ABOVE	N/A	15'	12'	12'	ENG. FABRIC
63'	64'	66'	10"	12"	2.25%	2 1/2" ABOVE	N/A	15'	11'	12'	ENG. FABRIC

\*NOTE: CENTER PANEL IS CENTERED ON R/W, TOTAL OF 4-12' AND 1-11' PANELS

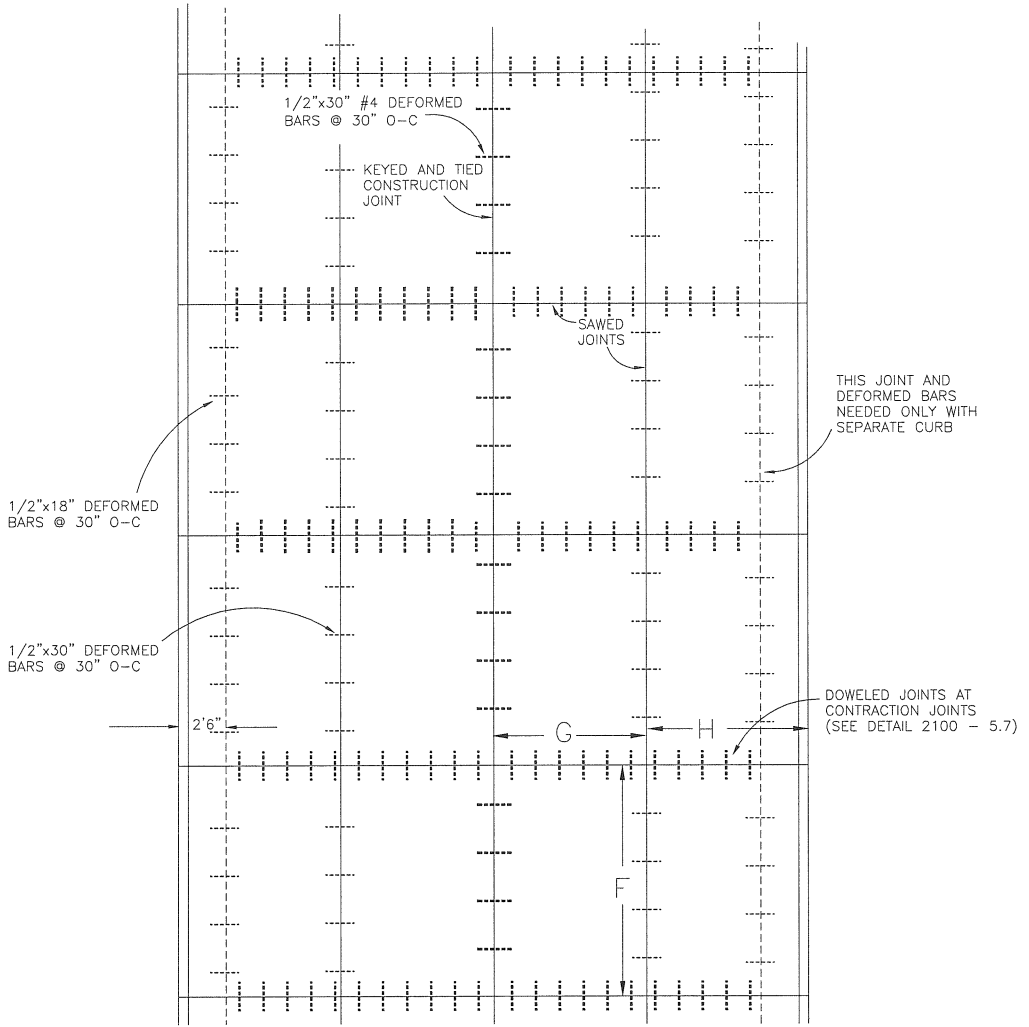

PLAN VIEW

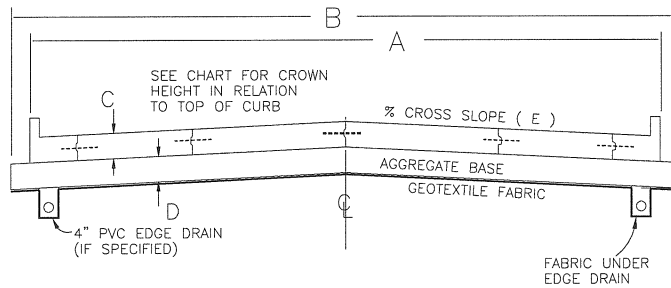

PAVEMENT PROFILE

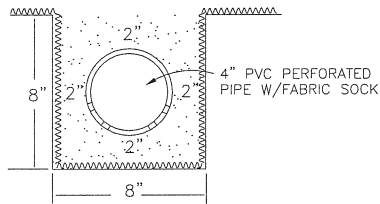

TRENCH DETAIL

SECTION NO.	2100	DRAWING NO.	5.1
REV.D.	2012		
<b>DOWELED CONCRETE PAVEMENT</b>			
CITY OF FARGO ENGINEERING DEPARTMENT			
APPROVED	<i>BEO</i>	DATE	<i>2-21-2012</i>

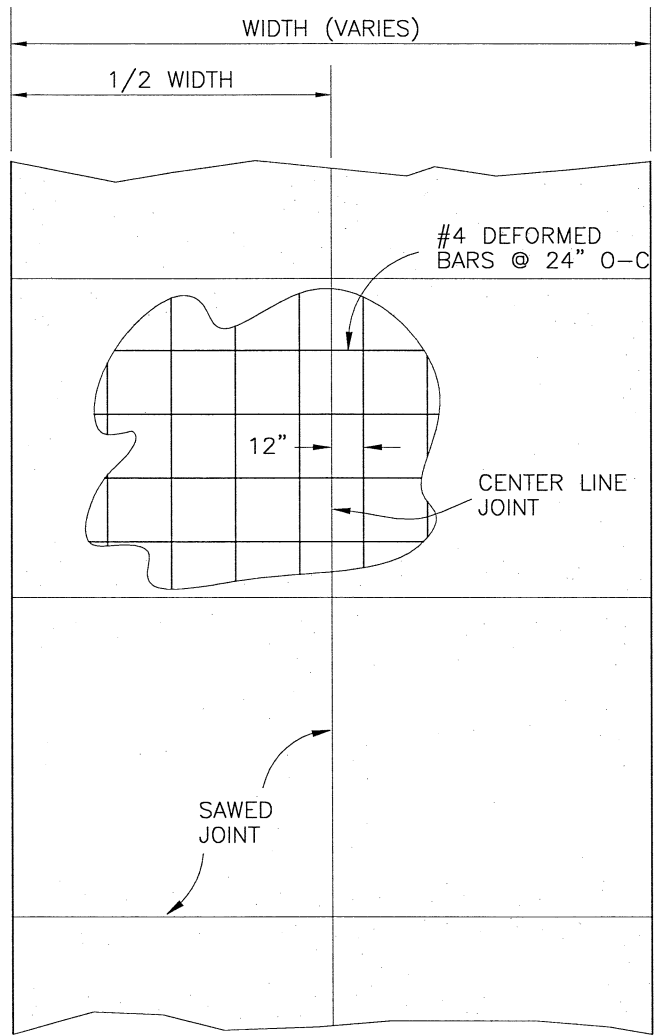

- NOTES:
1. JOINTS SHALL BE SAW CUT AND SEALED AS PER SECTION JOINT FILLING AND SEALING.
  2. 3" AGGREGATE BASE SHALL BE INCLUDED IN THE CONCRETE PAVEMENT BID ITEM.
  3. ALL CONSTRUCTION JOINTS SHALL BE TIED WITH #4 X 18" DEFORMED BARS @ 24" O-C.

PLAN

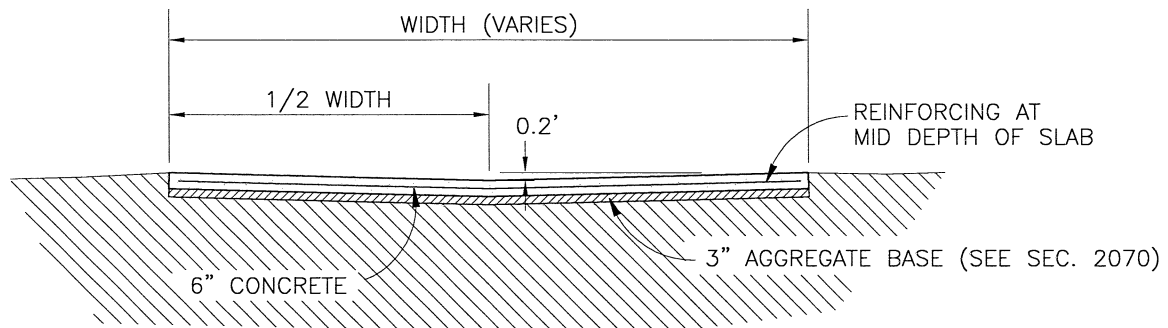

SECTION

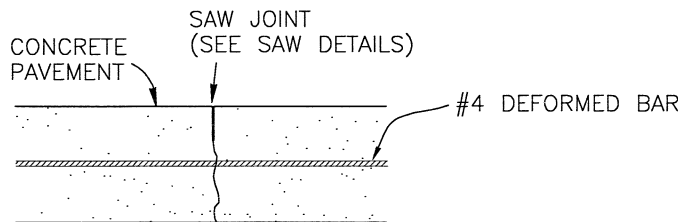

SAWED JOINT DETAIL

SECTION NO. 2100	DRAWING NO. 5.2
REV.D. 2014	
<b>REINFORCED CONCRETE ALLEY DETAILS</b>	
CITY OF FARGO ENGINEERING DEPARTMENT	
APPROVED <i>OME</i>	DATE 12/18/13

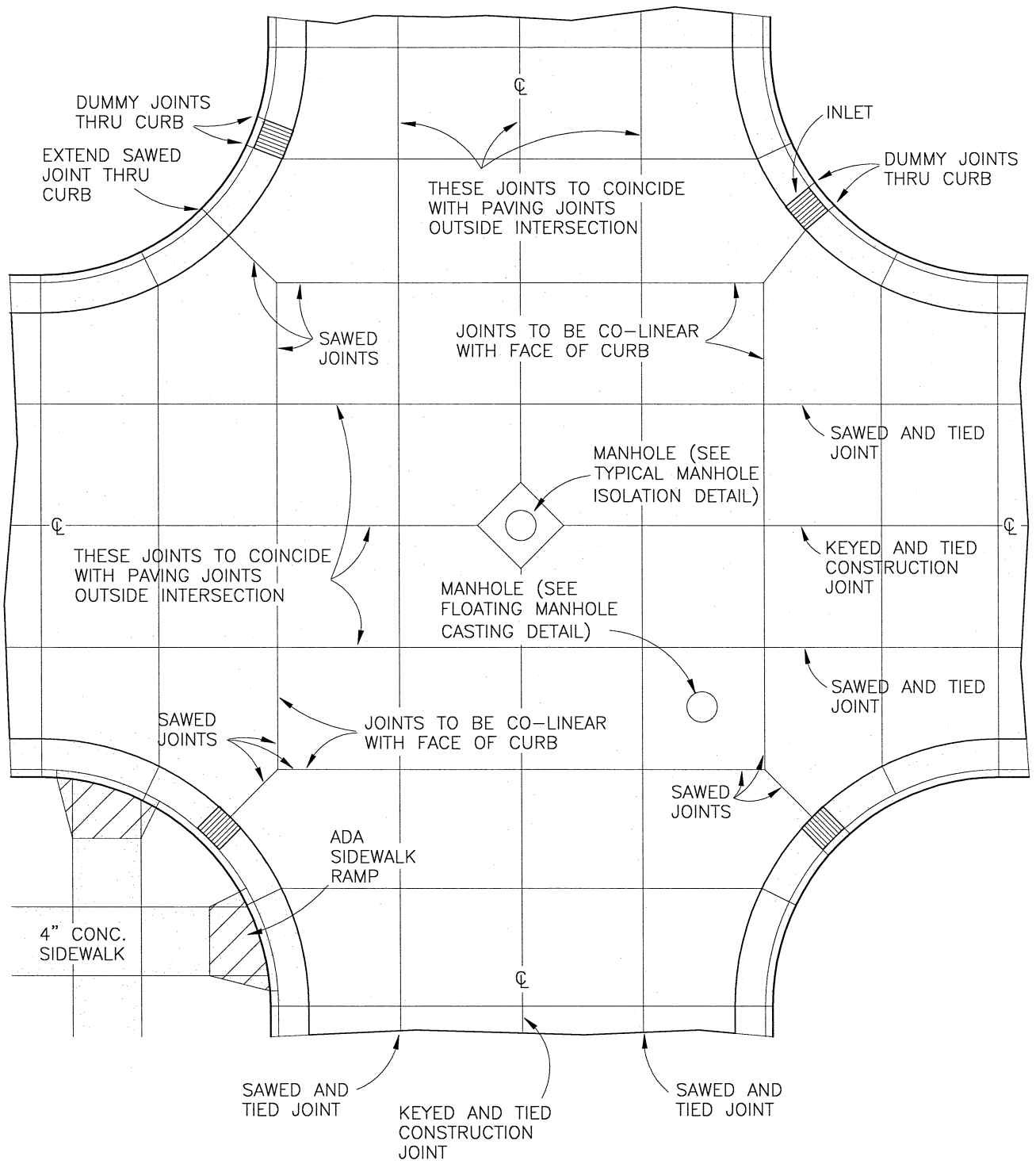

- NOTES:
1. ALL DIMENSIONS ARE VARIABLE, SEE PLANS AND PROPER CONCRETE PAVEMENT DETAIL FOR DIMENSIONS
  2. CURB AND GUTTER MAYBE INSTALLED INTEGRAL WITH THE CONCRETE PAVEMENT, EXCEPT AT THE FOLLOWING LOCATIONS WHERE IT SHALL BE INSTALLED SEPARATE:
    - A. ALL RADII (PC TO PC) THAT INCLUDE INLET CASTINGS.
    - B. ONE FULL PANEL HEIGHT ON EACH SIDE OF INLET CASTINGS NOT LOCATED IN A RADIUS.

SECTION NO.	2100	DRAWING NO.	5.3
REV.	D. 2014		
<b>TYPICAL CONCRETE INTERSECTION LAYOUT</b>			
CITY OF FARGO ENGINEERING DEPARTMENT			
APPROVED	<i>BME</i>	DATE	12/18/13

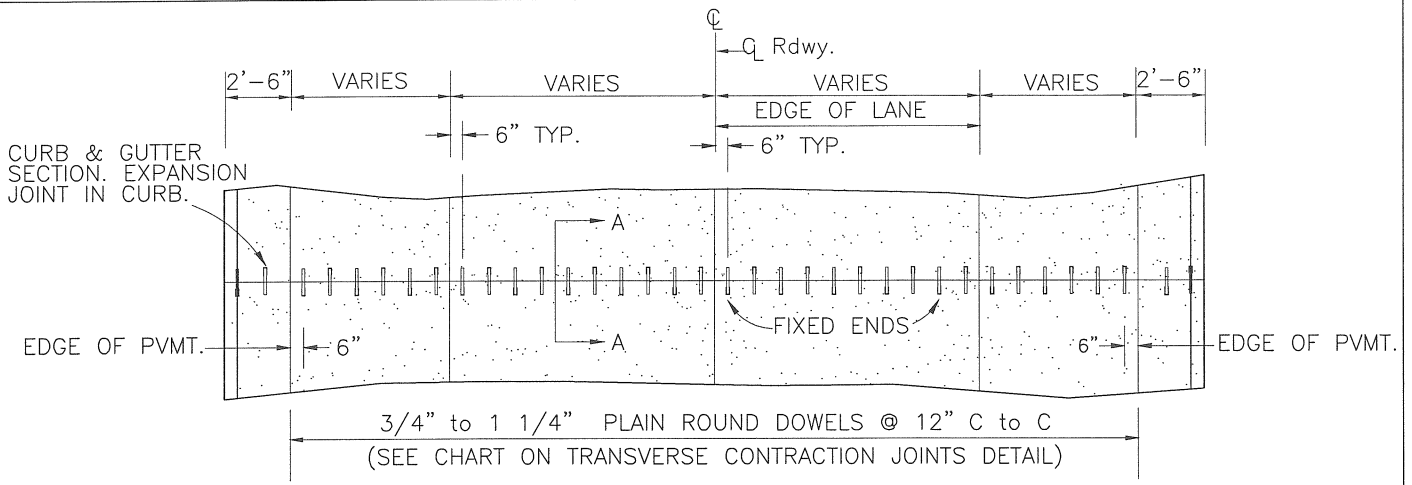

DOWEL BAR ASSEMBLY

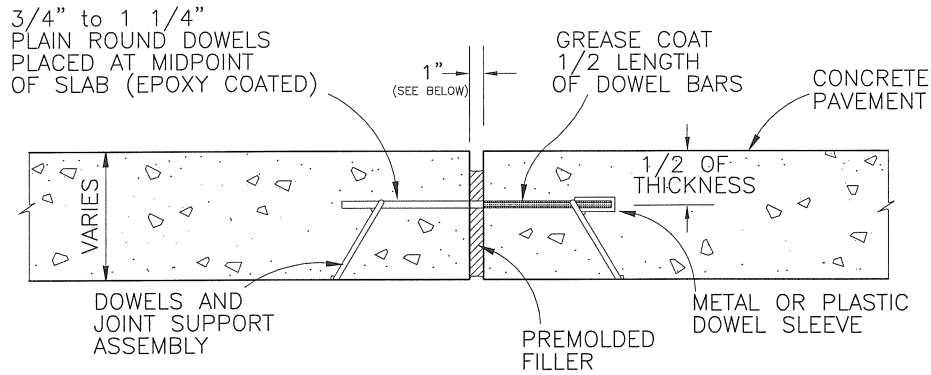

SECTION A-A

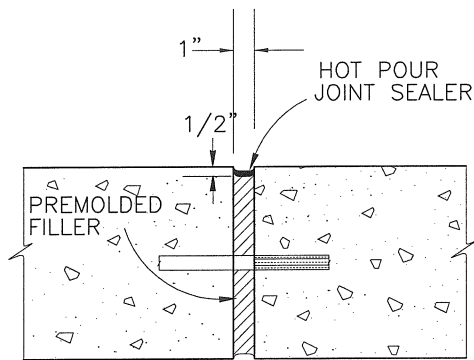

HOT POUR SEAL  
(UNLESS OTHERWISE NOTED)

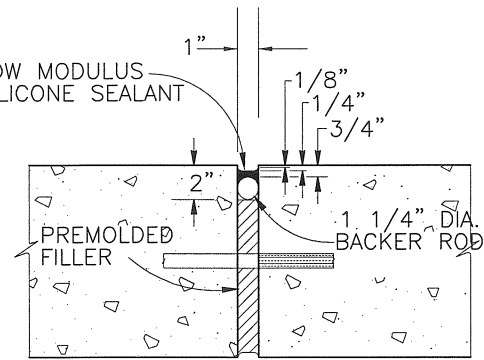

SILICONE SEAL  
(IF SPECIFIED)

- NOTES:
1. EXPANSION JOINT LOCATIONS SHOWN ON PLANS.
  2. EXPANSION JOINTS MUST BE INSTALLED ACROSS ENTIRE WIDTH OF CONCRETE PAVEMENT.
  3. PREMOLDED FILLER MUST CONFORM TO THE DIMENSIONS OF THE TYPE OF CURB.

SECTION NO.	2100	DRAWING NO.	5.4
REV.D.	2012		
<b>EXPANSION JOINT DETAIL</b>			
CITY OF FARGO ENGINEERING DEPARTMENT			
APPROVED	<i>BED</i>	DATE	<i>2-21-2012</i>

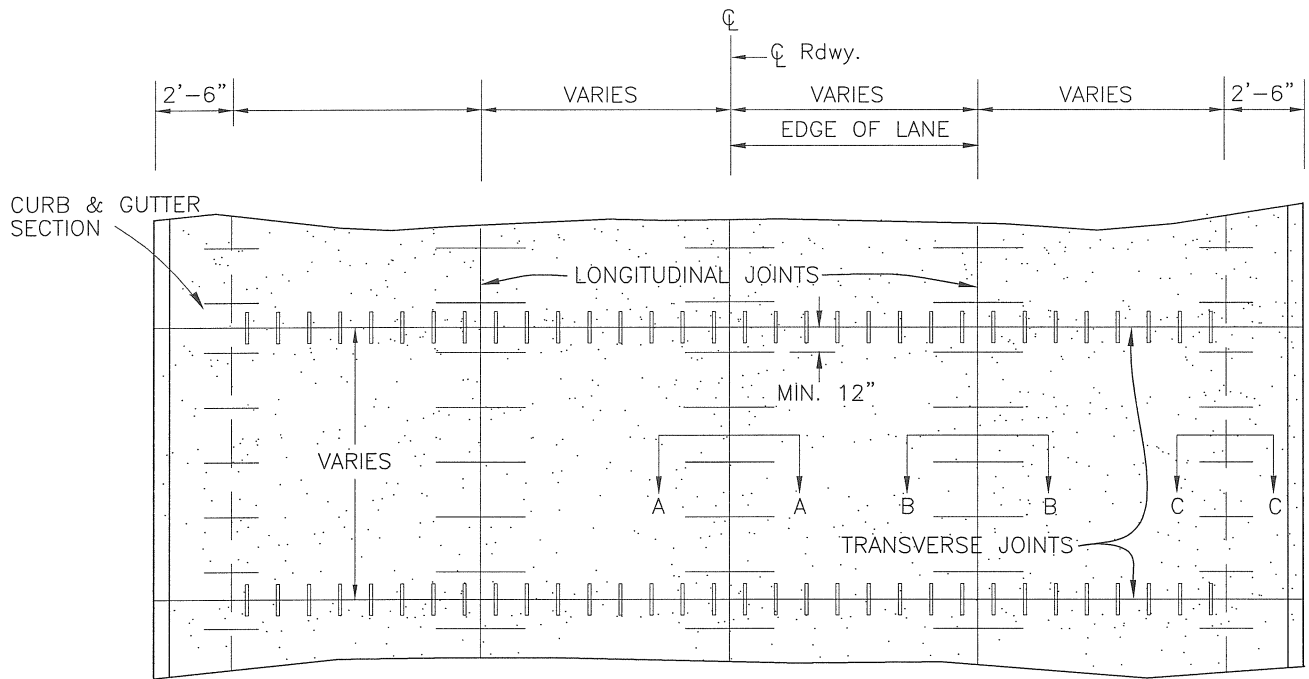

LONGITUDINAL JOINTS

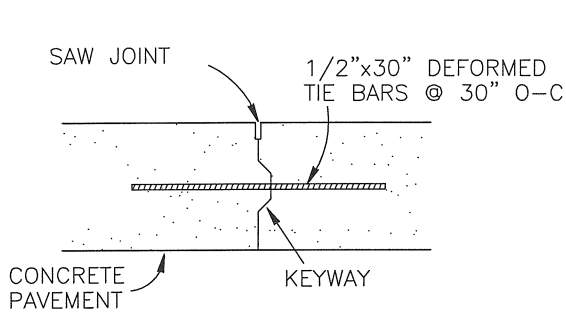

SECTION A-A  
LONGITUDINAL CONSTRUCTION JOINT

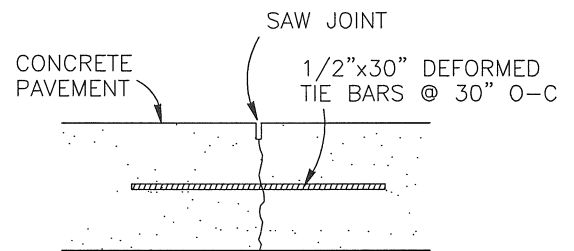

SECTION B-B  
SAWED LONGITUDINAL JOINT

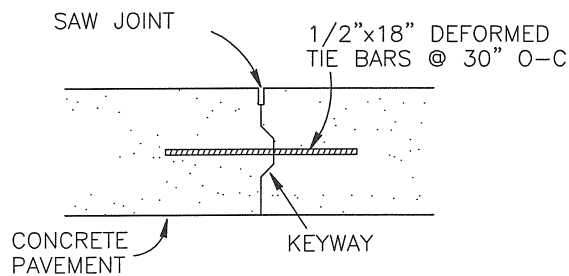

SECTION C-C  
LONGITUDINAL CONSTRUCTION JOINT

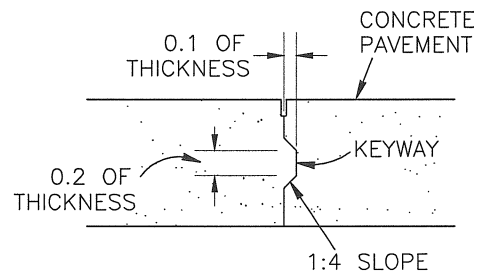

STANDARD KEYWAY  
DIMENSIONS

NOTES:

1. ALL LONGITUDINAL JOINTS SHALL BE TIED AND ALL LONGITUDINAL CONSTRUCTION JOINTS SHALL BE BOTH KEYED AND TIED.
2. SECTION C-C, THE JOINT AND DEFORMED TIE BARS NEEDED ONLY WITH SEPARATE CURB
3. SEE SAW JOINT DETAILS
4. WHERE TIE BARS ARE INSTALLED AND LATER STRAIGHTENED, GRADE 40 STEEL SHALL BE USED
5. ALL TIE BARS SHALL BE EPOXY COATED IN ACCORDANCE WITH AASHTO M284

SECTION NO. 2100	DRAWING NO. 5.5
REV.D. 2012	
<b>LONGITUDINAL JOINTS</b>	
CITY OF FARGO ENGINEERING DEPARTMENT	
APPROVED <i>BEO</i>	DATE <i>2-21-2012</i>

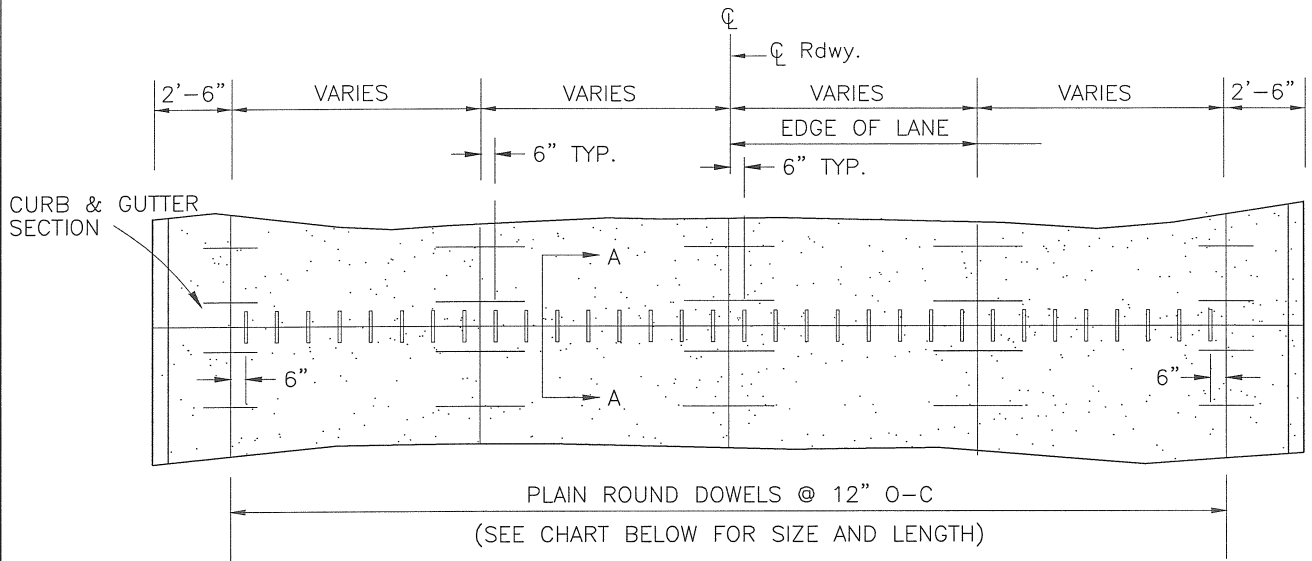

**TRANSVERSE CONTRACTION JOINT**  
**DOWEL ASSEMBLY**

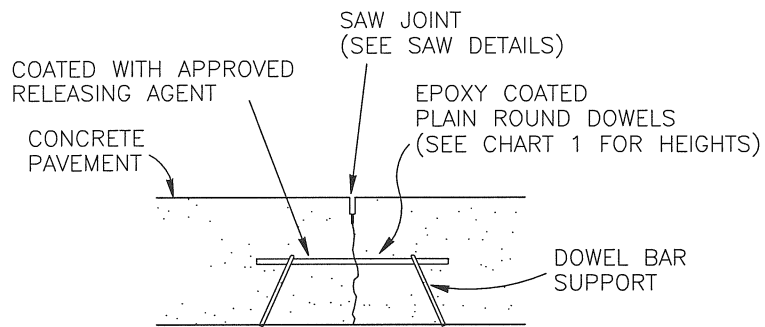

**SECTION A-A**  
**DOWEL ASSEMBLY**

- NOTES:  
1. ALL DOWELS SHALL BE EPOXY COATED IN ACCORDANCE WITH AASHTO M254.

**CHART 1**

DOWELED JOINT			
PAVEMENT THICKNESS	DOWEL BAR SIZE	HEIGHT TO CENTER	TOTAL DOWEL LENGTH
7"	1"	3 1/2"	18"
8 to 10"	1 1/4"	4 1/2"	18"
10.5 to 12"	1 1/2"	5 1/2"	18"
NOTE: ALL DOWELS ARE TO BE SPACED AT 12" O-C			

SECTION NO. 2100	DRAWING NO. 5.6
REV.D. 2012	
<b>TRANSVERSE CONTRACTION JOINTS</b>	
CITY OF FARGO ENGINEERING DEPARTMENT	
APPROVED <i>BED</i>	DATE <i>2-21-2012</i>

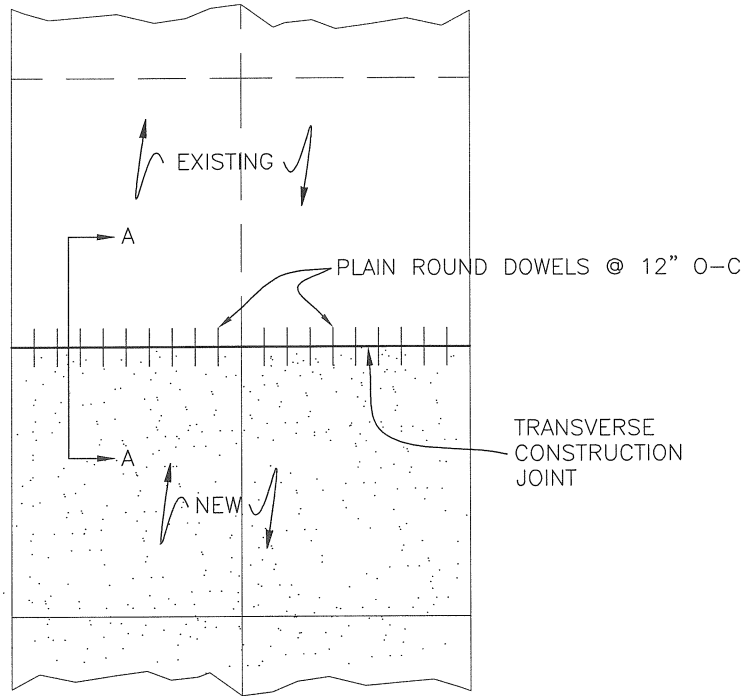

CONSTRUCTION JOINT  
EXISTING TO NEW CONCRETE PAVEMENT

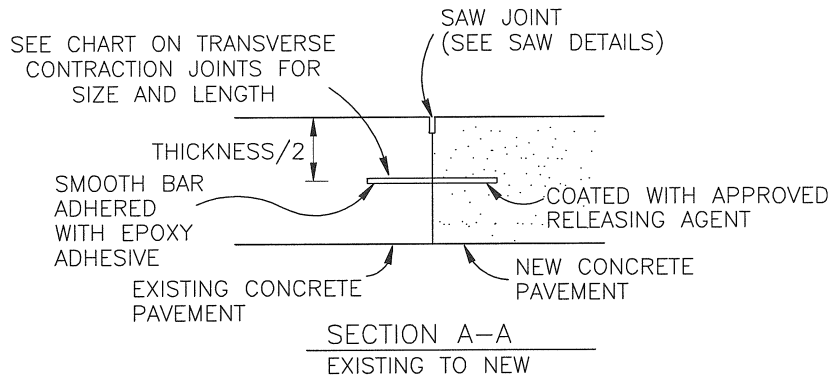

SECTION A-A  
EXISTING TO NEW

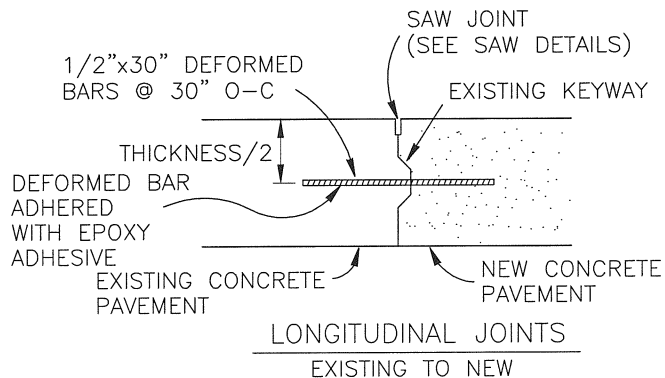

LONGITUDINAL JOINTS  
EXISTING TO NEW

SECTION NO.	2100	DRAWING NO.	5.7
REV.D.	2012		
<b>CONSTRUCTION JOINT DETAILS</b>			
CITY OF FARGO ENGINEERING DEPARTMENT			
APPROVED	<i>BEO</i>	DATE	2-21-2012

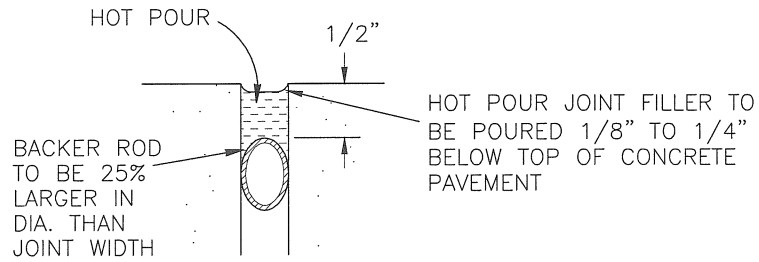

JOINT FILLER DETAIL  
(SEE NOTE 1)

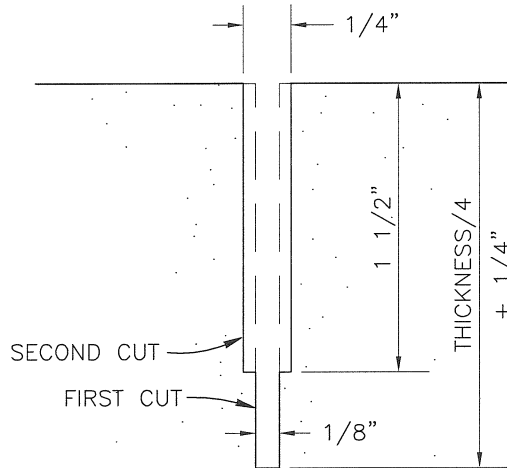

SAW JOINT DETAIL  
(SEE NOTE 2)

- NOTES:
1. THE JOINT FILLER DETAIL APPLIES TO BOTH TRANSVERSE AND LONGITUDINAL JOINTS.
  2. SAW JOINT DETAIL – THE FIRST & SECOND CUT SHALL BE COMPLETED ON ALL CONTRACTION JOINTS. ON ALL CONSTRUCTION JOINTS ONLY A CUT CONFORMING TO THE DIMENSIONS OF THE SECOND CUT SHOWN SHALL BE COMPLETED.
  3. ALL JOINTS SHALL BE FILLED.

SECTION NO. 2100	DRAWING NO. 5.8
REV.D. 2012	
<i>SAW JOINT DETAIL</i>	
CITY OF FARGO ENGINEERING DEPARTMENT	
APPROVED <i>TED</i>	DATE <i>2-21-2012</i>



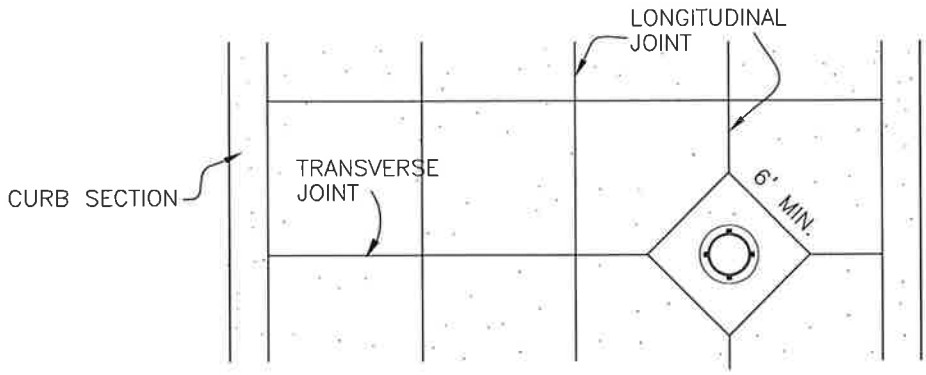

PLAN VIEW

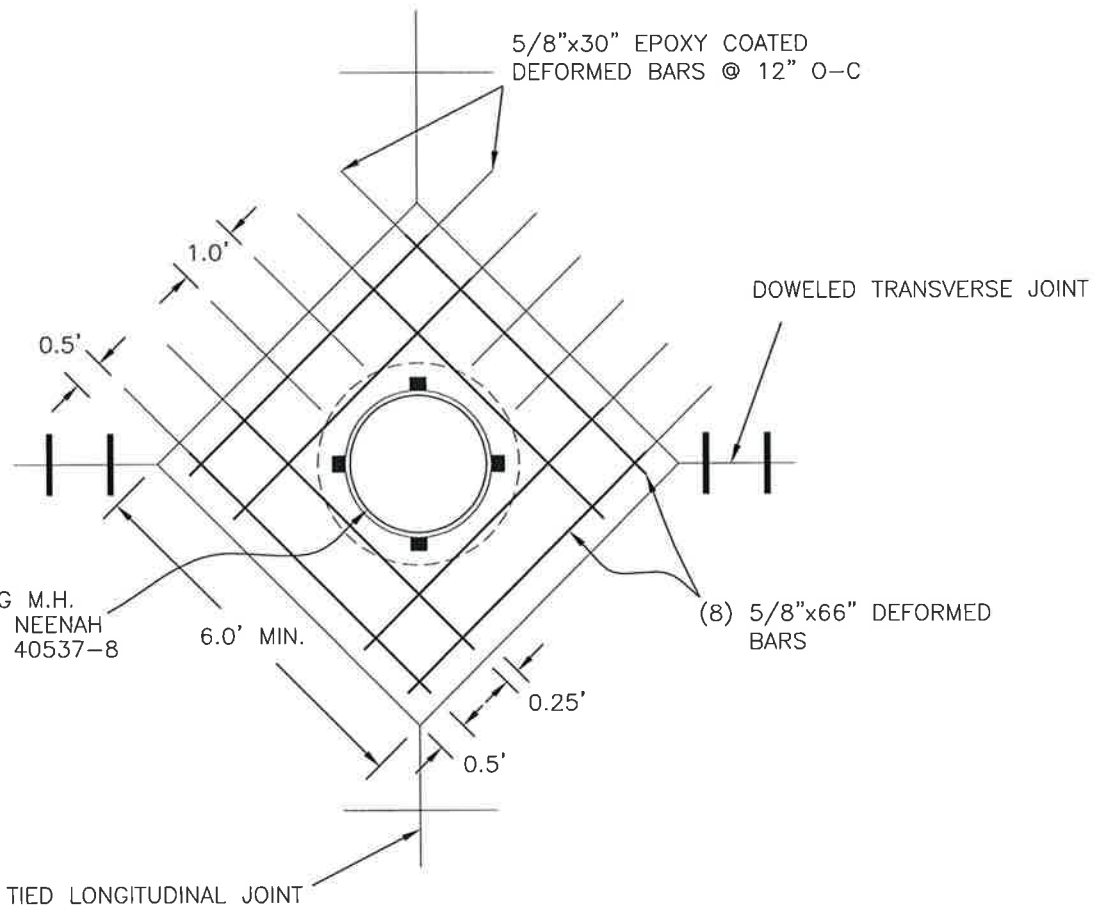

MANHOLE ISOLATION DETAIL

NOTE:  
 1. ALL 4 SIDES SHALL BE KEYED W/2 SIDES BEING KEYED AND TIED AS SHOWN. SEE LONGITUDINAL JOINTS DETAIL FOR KEYWAY DIMENSIONS.

SECTION NO.	2100	DRAWING NO.	5.9
REV.D.	2015		
<b>TYPICAL MANHOLE ISOLATION DETAIL</b>			
CITY OF FARGO ENGINEERING DEPARTMENT			
APPROVED	<i>CME</i>	DATE	<i>12/3/14</i>

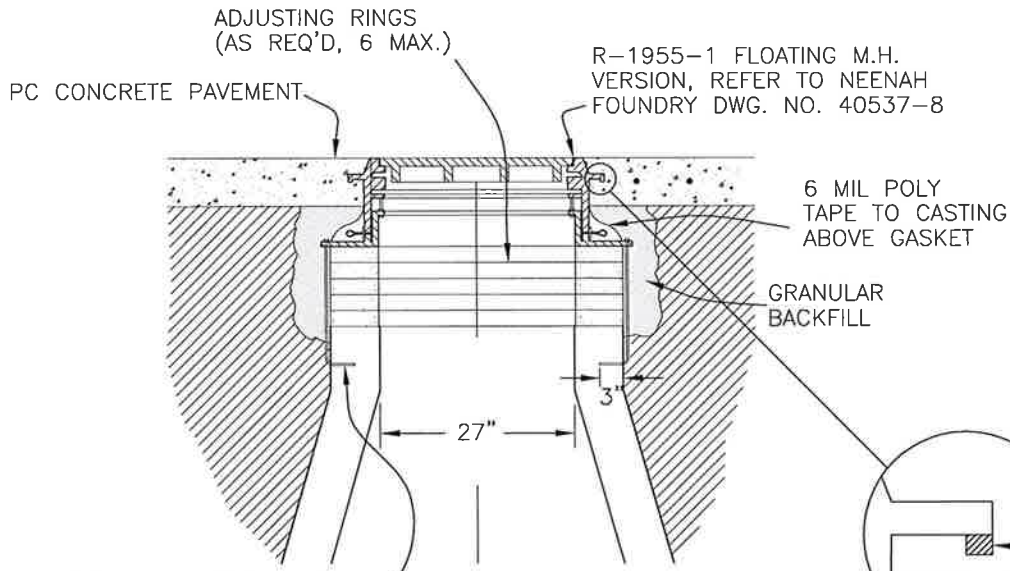
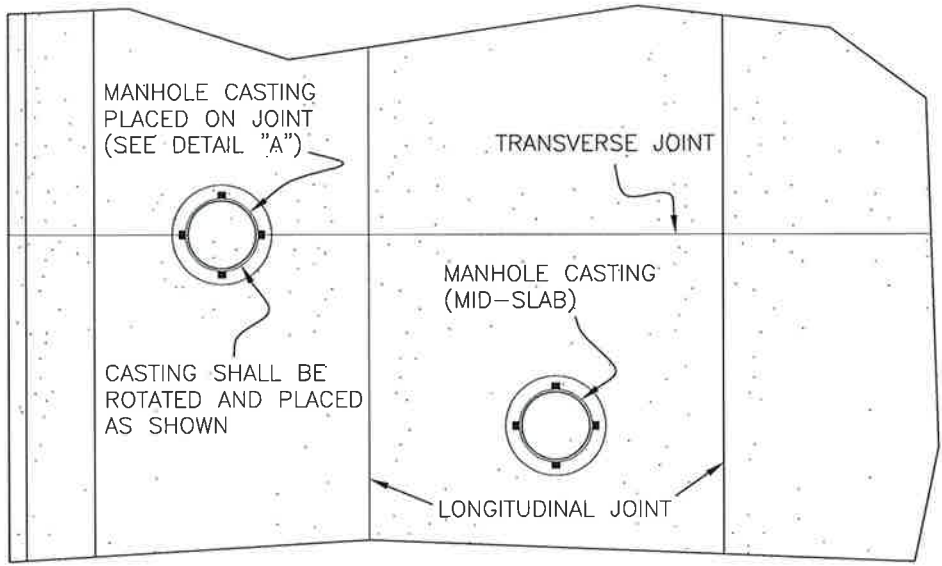

3/4" DIA S.S "J" BOLT W/NUT, TO EXTEND 5" BELOW ADJ. RINGS, 4 PER CASTING, LENGTH TO VARY WITH NUMBER OF ADJUSTING RINGS

FLOATING MANHOLE  
NEENAH FOUNDRY TYPE

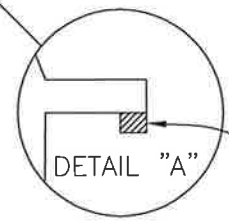

REMOVE ALL (4) HOOK PORTIONS FROM THE FLANGES, WHEN CASTING IS PLACED ON TRANSVERSE JOINTS AND COAT OUTER SURFACE OF CASTING W/APPROVED RELEASING AGENT

- NOTES:
1. THIS DETAIL APPLIES TO ALL MH's LOCATED WITHIN THE CONCRETE PAVING SECTION.
  2. FURNISH / INSTALL WILL BE PAID UNDER THE "CASTING TO GRADE" BID ITEM.

SECTION NO. 2100	DRAWING NO. 5.10
REV.D. 2015	
<b>FLOATING MANHOLE CASTING DETAIL</b>	
CITY OF FARGO ENGINEERING DEPARTMENT	
APPROVED <i>CME</i>	DATE 12/3/14

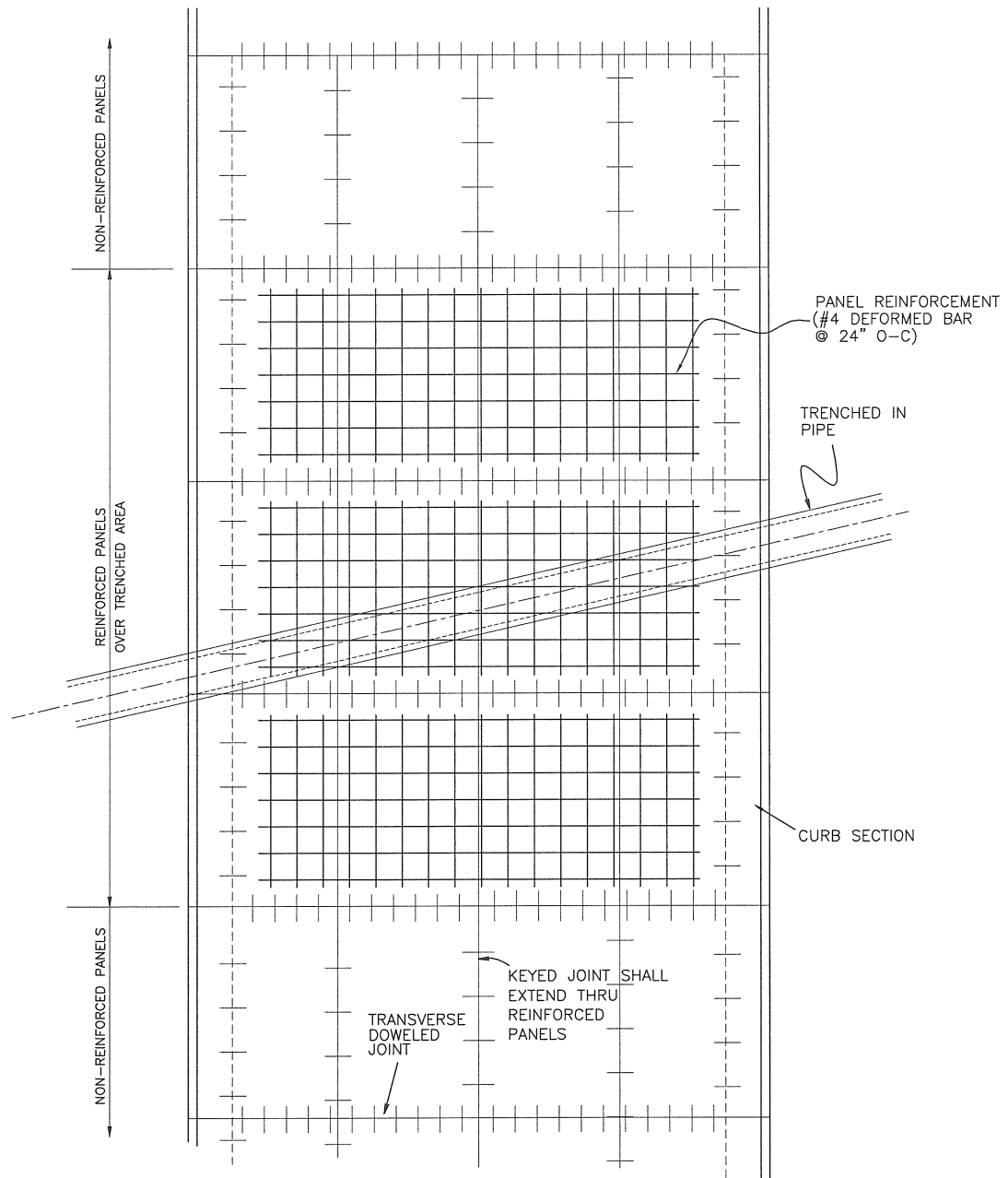

NOTES:

1. AREAS FOR REINFORCEMENT SHALL BE DETERMINED BY THE ENGINEER USING THE PLAN SHEETS AS A GUIDELINE. PAYMENT FOR REINFORCEMENT SHALL BE INCIDENTAL TO THE PRICE OF THE CONCRETE PAVEMENT.
2. THE COMPLETE PANEL SHALL BE REINFORCED IF ANY PART OF THE PANEL IS WITHIN 5' OF THE PIPE CENTERLINE.
3. REBAR MAT SHALL BE SUPPORTED BY CHAIRS AT THE MID-DEPTH POINT OF THE SLAB.
4. REBAR SHALL STOP WITHIN 1' OF THE DOWELED CONTRACTION JOINT AT THE ADJACENT NON-REINFORCED PANEL.

SECTION NO.	2100	DRAWING NO.	5.11
REV.D.	2012		
<b>TRENCH REINFORCEMENT DETAIL</b>			
CITY OF FARGO ENGINEERING DEPARTMENT			
APPROVED	<i>BEO</i>	DATE	<i>2-21-2012</i>

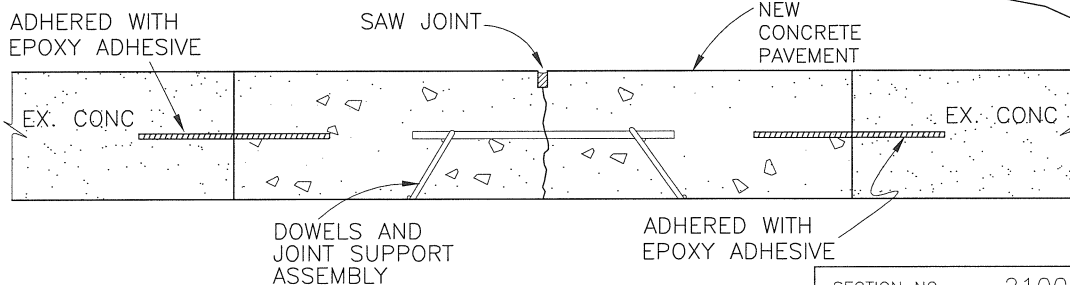
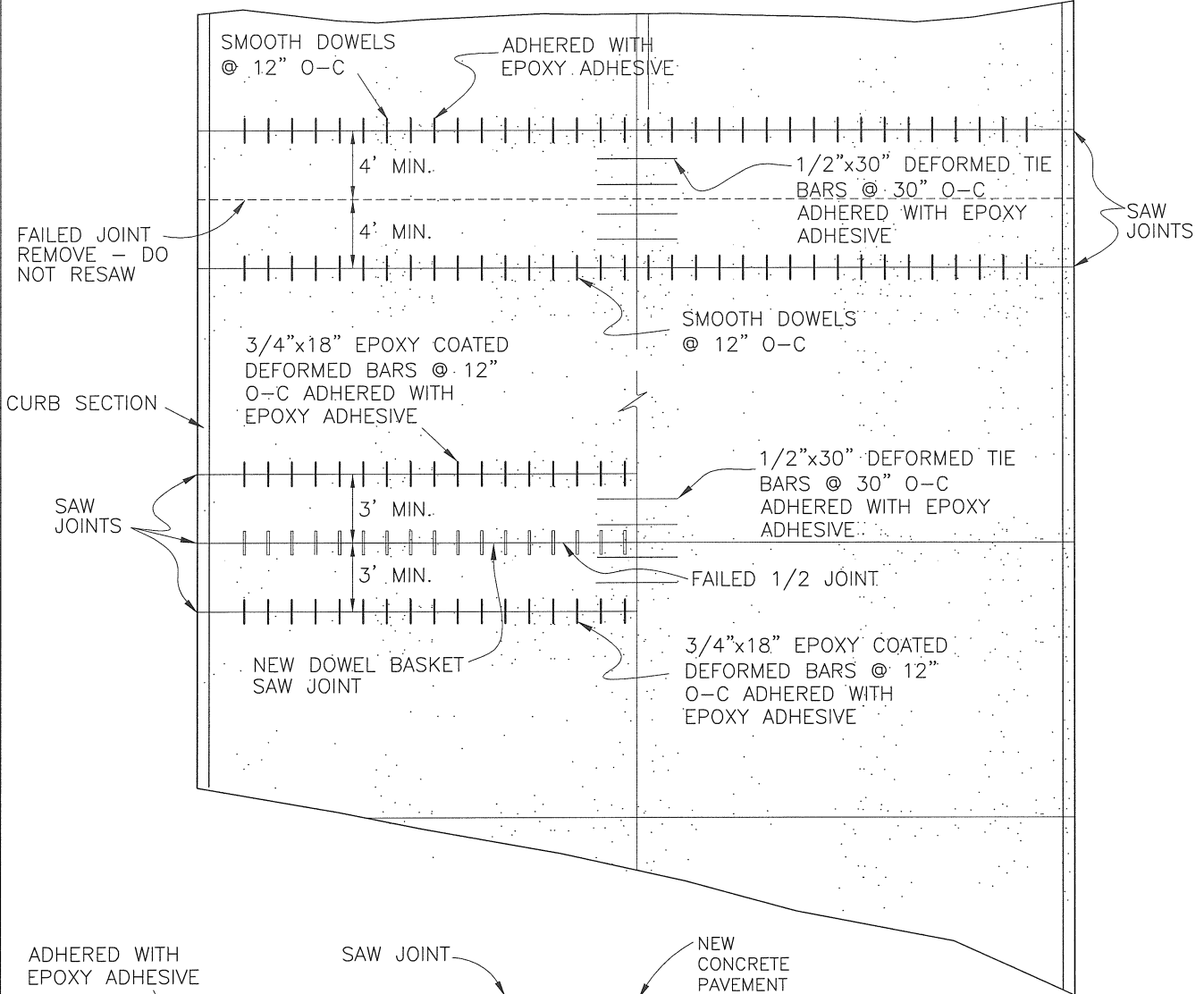
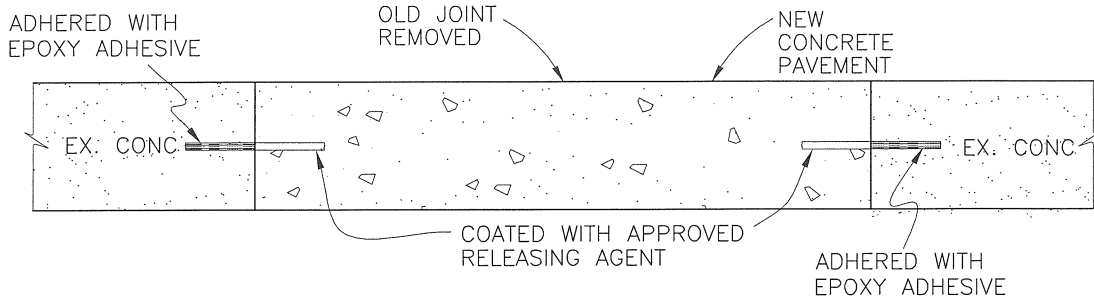

- NOTES:
1. SMOOTH DOWELS - SEE CHART ON TRANSVERSE CONTRACTION JOINTS DETAIL FOR SIZE AND LENGTH.
  2. SEE SAW JOINT DETAIL.
  3. THIS DETAIL SHALL ONLY APPLY TO REHABILITATION PROJECTS WHERE DESIGNATED ON THE PLANS.

SECTION NO. 2100 DRAWING NO. 5.12

REV.D. 2012

**JOINT REPAIR  
DETAIL**

CITY OF FARGO  
ENGINEERING DEPARTMENT

APPROVED *BEO*

DATE 2-21-2012

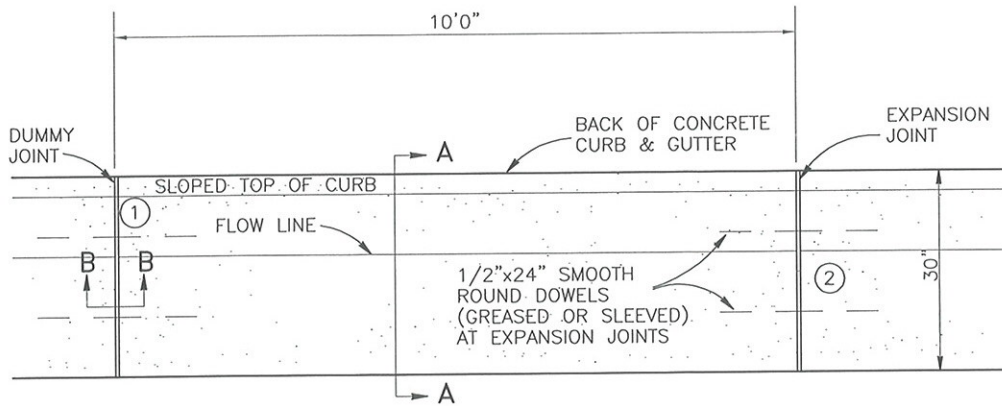

### CURB & GUTTER PLAN

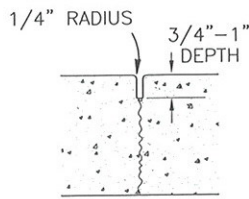

SECTION B-B

- ① DUMMY JOINT
  - (1) PLACE AT 10'0" O.C. FOR ASPHALT PAVING
  - (2) MATCH PANEL SPACING FOR CONCRETE PAVEMENT
- ② 1" EXPANSION JOINTS
  - (1) PLACE AT P.C.'S AND HIGH POINTS FOR ASPHALT PAVING
  - (2) MATCH EXPANSION JOINTS ON CONCRETE PAVEMENT

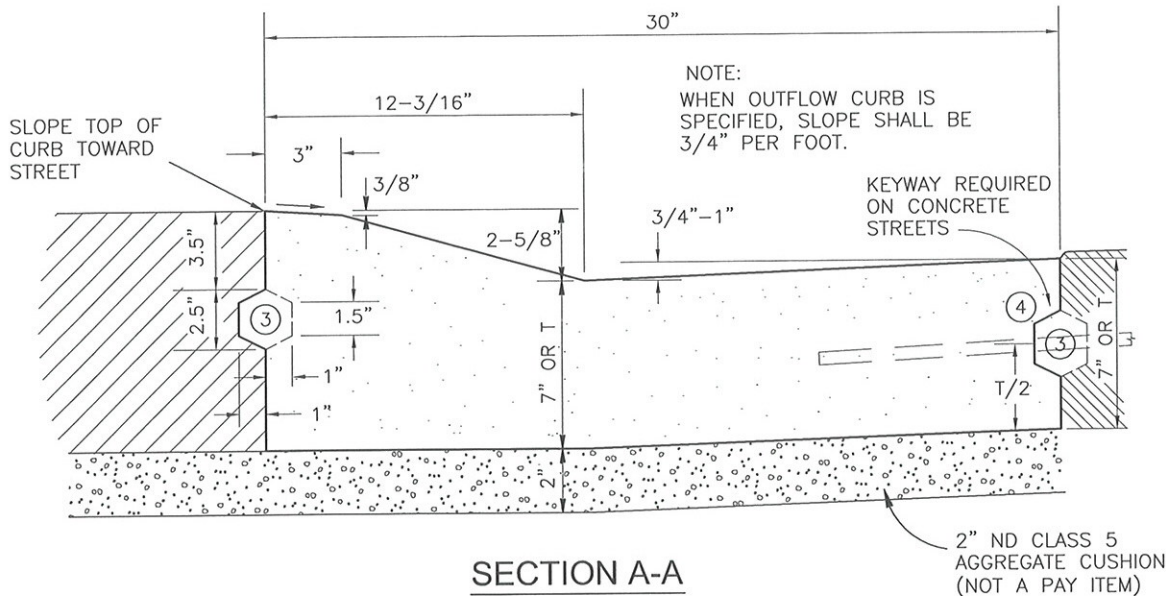

SECTION A-A

- ③ NOTE:
  - (1) MALE KEYWAY REQUIRED FOR EXTRUDED CURB CONSTRUCTION
  - (2) FEMALE KEYWAY FOR USE WITH FORMS (INDICATED WITH DASHED LINES)
- ④ 1/2"x18" DEFORMED BARS AT 30" O.C. & KEYWAY REQUIRED WHEN SEPARATE CURB IS INSTALLED WITH CONCRETE PAVING

NOTE:  
DIMENSION T SHALL MATCH THE THICKNESS OF THE ADJOINING CONCRETE SLAB WITH EITHER INTEGRAL OR SEPARATE CURB

SECTION NO. 2100	DRAWING NO. 5.13
REV.D. 2013	
<b>MOUNTABLE (TYPE I) CURB &amp; GUTTER</b>	
CITY OF FARGO ENGINEERING DEPARTMENT	
APPROVED <i>OME</i>	DATE 1-2-13



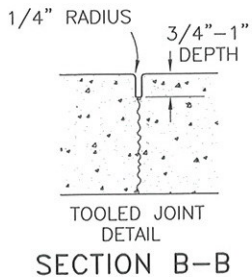
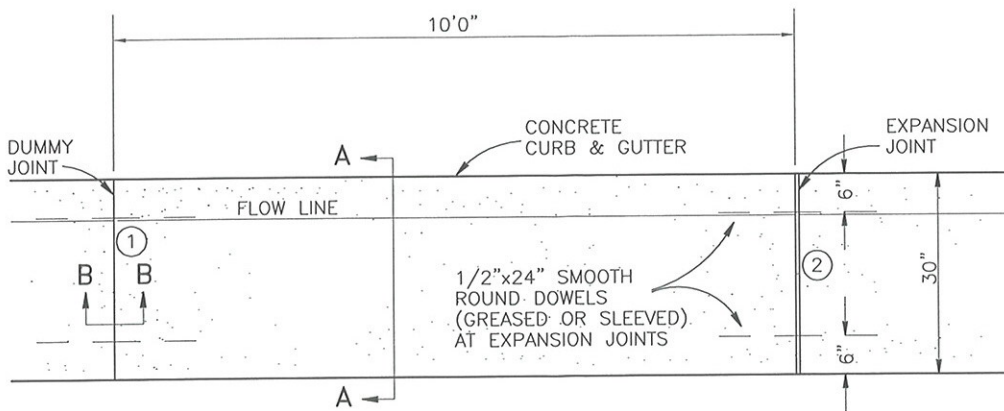

**CURB & GUTTER PLAN**

- ① DUMMY JOINT
  - (1) PLACE AT 10'0" O.C. FOR ASPHALT PAVING
  - (2) MATCH PANEL SPACING FOR CONCRETE PAVEMENT
- ② 1" EXPANSION JOINTS
  - (1) PLACE AT P.C.'S AND HIGH POINTS FOR ASPHALT PAVING
  - (2) MATCH EXPANSION JOINTS ON CONCRETE PAVEMENT

NOTE:  
WHEN OUTFLOW CURB IS SPECIFIED SLOPE WILL BE 3/8" PER FOOT

CURB SECTION WHEN DROPPED FOR DRIVEWAY OR PUBLIC SIDEWALK OPENING.  
(1.5' TRANSITION CURB FOR SIDEWALK AND DRIVEWAY)

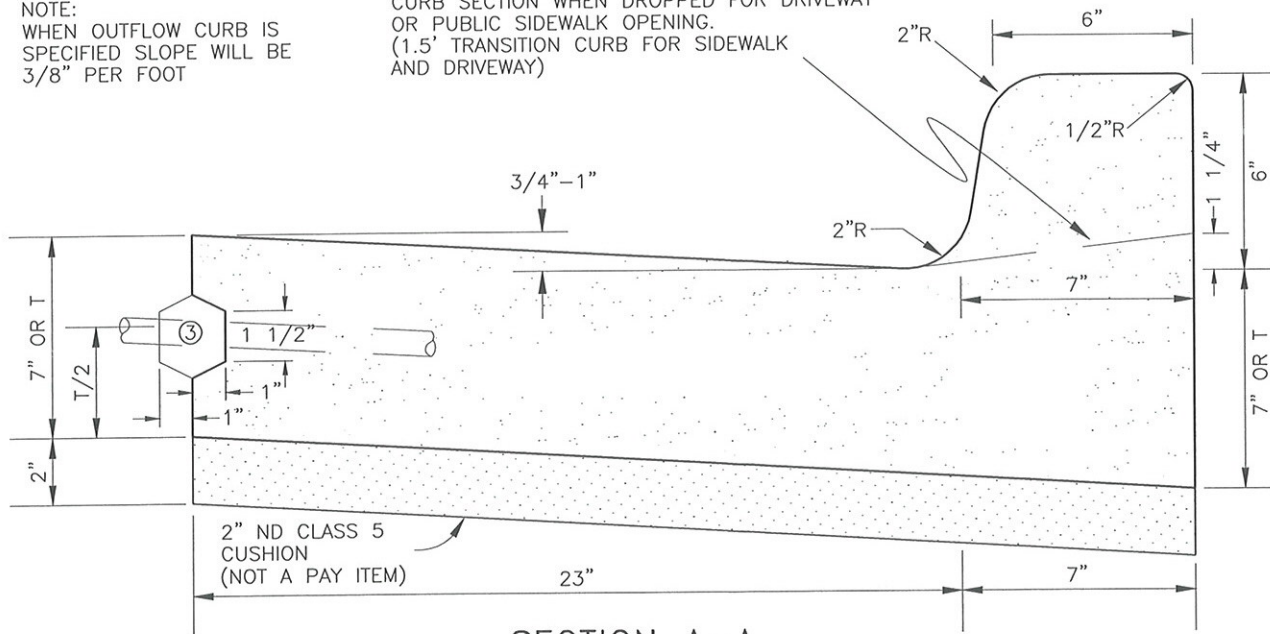

**SECTION A-A**

- ③ 1/2"x18" DEFORMED BARS AT 30" O.C. & KEYWAY REQUIRED WHEN SEPARATE CURB IS INSTALLED WITH CONCRETE PAVING

NOTE:  
DIMENSION T SHALL MATCH THE THICKNESS OF THE ADJOINING CONCRETE SLAB WITH EITHER INTEGRAL OR SEPARATE CURB

SECTION NO. 2100	DRAWING NO. 5.14
REV.D. 2013	
<b>STANDARD (TYPE II) CURB &amp; GUTTER</b>	
CITY OF FARGO ENGINEERING DEPARTMENT	
APPROVED <i>CME</i>	DATE 1-2-13

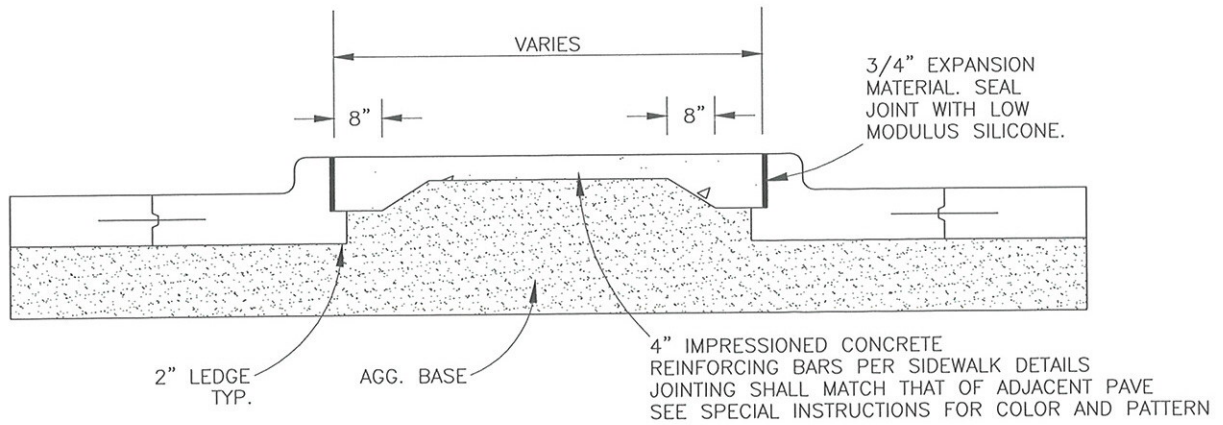

### MEDIAN SECTION

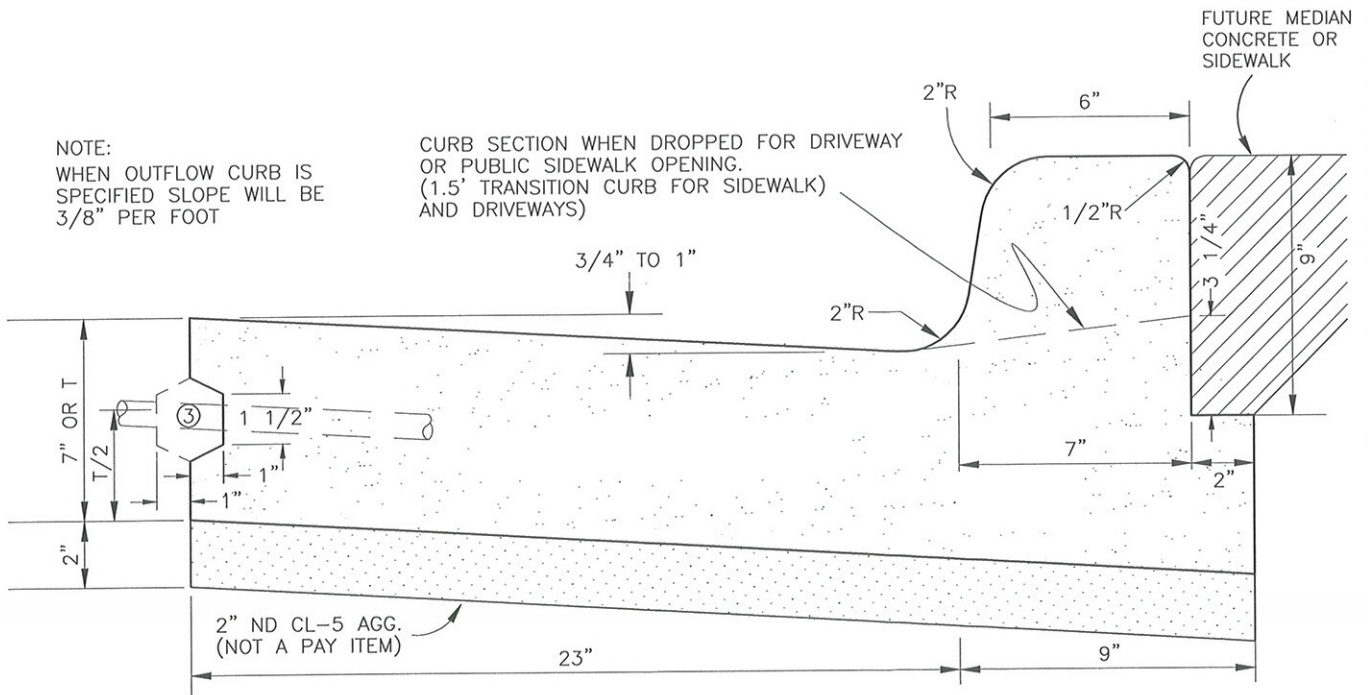

### CURB & GUTTER SECTION

- ③ 1/2"x18" DEFORMED BARS AT 30" O.C. & KEYWAY REQUIRED WHEN SEPARATE CURB IS INSTALLED WITH CONCRETE PAVING

#### NOTES:

- DIMENSION T SHALL MATCH THE THICKNESS OF THE ADJOINING CONCRETE WITH EITHER INTEGRAL OR SEPARATE CURB
- SEE CURB & GUTTER PLAN VIEW ON TYPE II CURB & GUTTER DETAIL FOR CURB & GUTTER JOINTING & REINFORCING
- PAID FOR AS:  
CURB & GUTTER - STANDARD (TYPE II)

SECTION NO. 2100	DRAWING NO. 5.15
REV.D. 2013	
<b>MEDIAN CONCRETE AND LEDGE CURB &amp; GUTTER</b>	
CITY OF FARGO ENGINEERING DEPARTMENT	
APPROVED <i>OME</i>	DATE 1-2-13

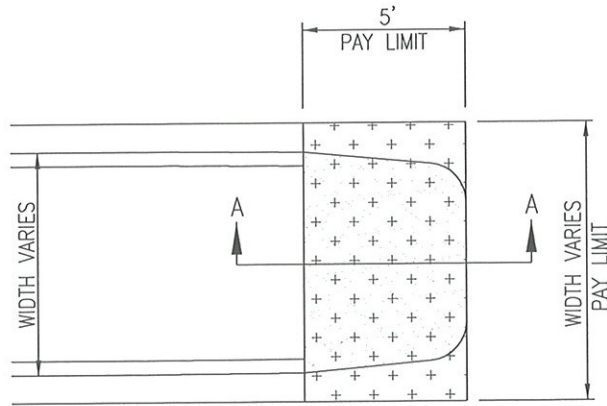

CONCRETE MEDIAN NOSE DETAIL

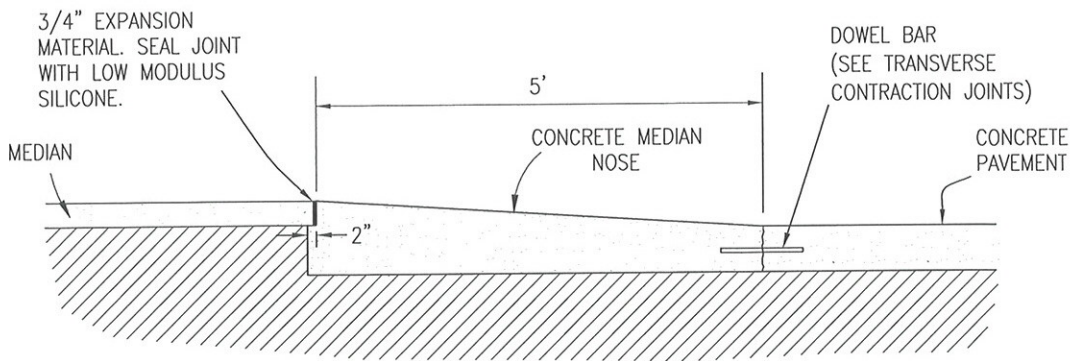

SECTION A-A

NOTE:  
1. PAID AS "MEDIAN NOSE - CONCRETE"

SECTION NO. 2100	DRAWING NO. 5.16
REV.D. 2013	
<b>CONCRETE MEDIAN NOSE DETAIL</b>	
CITY OF FARGO ENGINEERING DEPARTMENT	
APPROVED <i>CME</i>	DATE 1-2-13



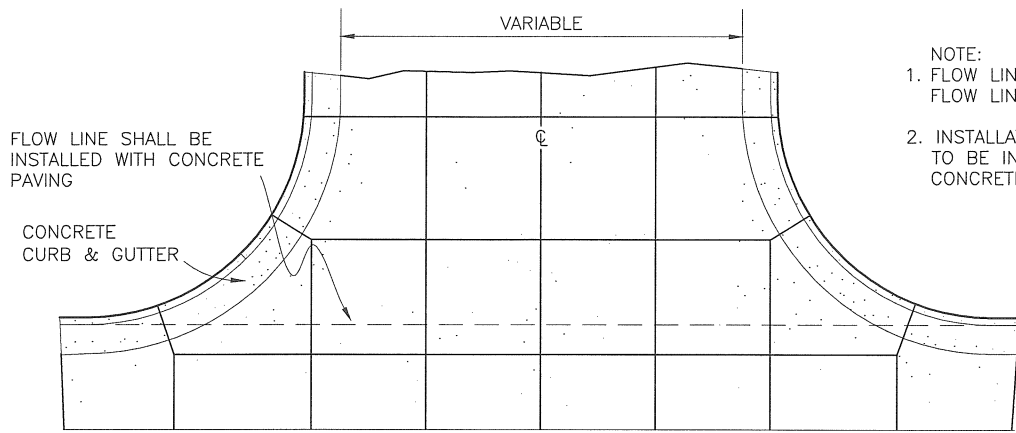

FLOW LINE SHALL BE INSTALLED WITH CONCRETE PAVING

CONCRETE CURB & GUTTER

- NOTE:
1. FLOW LINE TO ALIGN WITH FLOW LINE OF C&G
  2. INSTALLATION OF FLOW LINE TO BE INCIDENTAL TO CONCRETE PAVING ITEM

### CONCRETE STREET SECTION

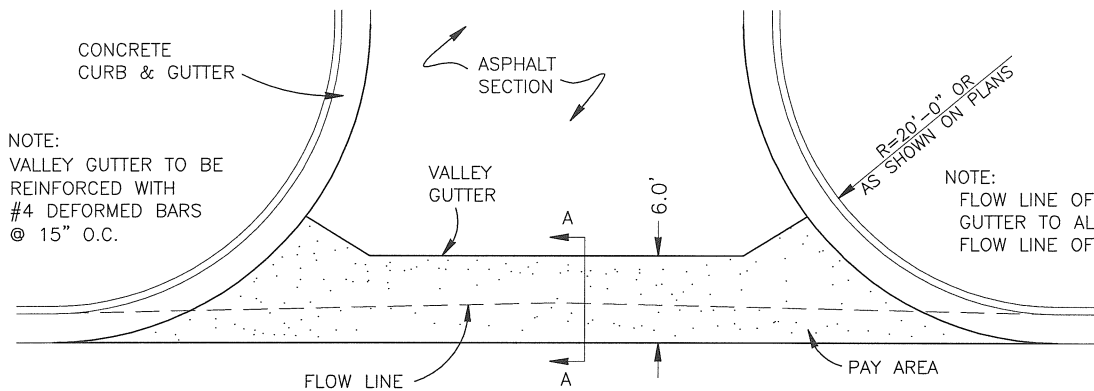

NOTE:  
VALLEY GUTTER TO BE REINFORCED WITH #4 DEFORMED BARS @ 15" O.C.

NOTE:  
FLOW LINE OF VALLEY GUTTER TO ALIGN WITH FLOW LINE OF C&G

### ASPHALT STREET SECTION

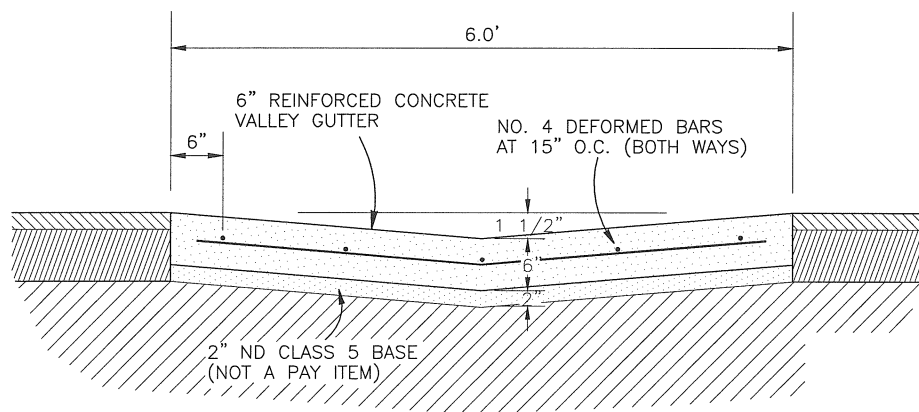

### SECTION A-A

- NOTE:
- (1) AGG. BASE REQUIRED UNDER ENTIRE VALLEY GUTTER (NOT A PAY ITEM)
  - (2) REFER TO PLANS FOR LENGTH OF VALLEY GUTTER

SECTION NO. 2100	DRAWING NO. 5.17
REV. D. 2012	
<b>VALLEY GUTTER DETAIL</b>	
CITY OF FARGO ENGINEERING DEPARTMENT	
APPROVED <i>BEO</i>	DATE <i>2-21-2012</i>

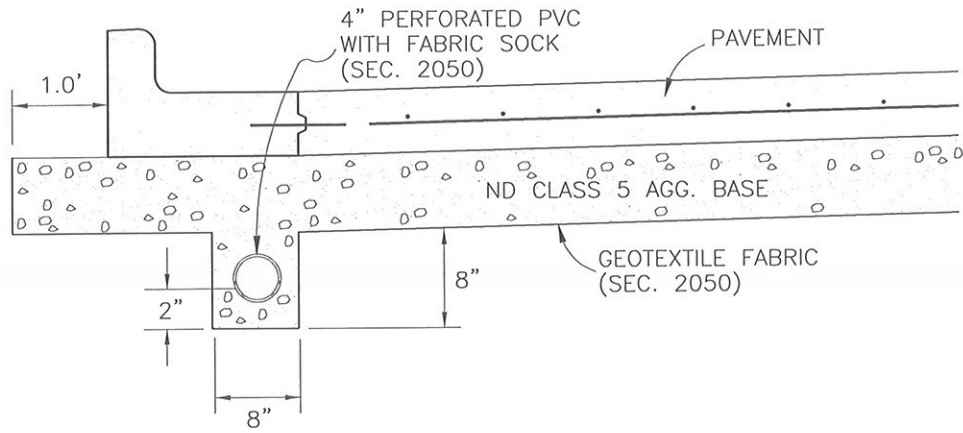

EDGE DRAIN PLACEMENT

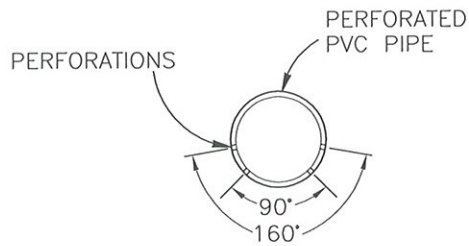

4" PVC PIPE DETAIL

TYPE OF PIPE:

1. The pipe shall be polyvinylchloride SCHEDULE 40 sewer pipe with solvent cemented joints as specified in ASTM Spec. No. F-758.
2. Perforations shall be circular and  $1/4" \pm 1/16"$  in diameter. They should be arranged in rows parallel to the axis of the pipe and shall be spaced approximately 3" center to center along the rows. The spigot end of the pipe shall be unperforated for a length equal to the depth of the socket. The placement and total numbers of the rows shall be as shown above with an allowable tolerance of  $\pm 10"$ .
3. Molded Fittings shall be in accordance with ASTM Spec No. D 2665 or F1866. Cost of fitting and installation to be included in the price bid for 4" PVC Edge Drain.
4. The perforated PVC shall be encased in a Geotextile Fabric per Section 2050. Cost of fabric to be included in the price bid for 4" PVC Edge Drain.
5. PIPE SIZE: 4" diameter IPS SCH 40
6. ROWS OF PERFORATIONS: 4
7. HOLE SIZE: 1/4"
8. HOLE SPACING PER ROW: 3"

NOTES:

1. SEE STORM INLET/PVC DRAIN PIPE DETAIL IN SECTION 1500 FOR ADDITIONAL DETAILS.

SECTION NO. 2100	DRAWING NO. 5.18
REV.D. 2013	
<b>4" PVC EDGE DRAIN DETAIL</b>	
CITY OF FARGO ENGINEERING DEPARTMENT	
APPROVED <i>CME</i>	DATE 1-2-13

**CITY OF FARGO SPECIFICATIONS  
CONCRETE SIDEWALKS AND DRIVEWAYS**

**PART 1  
DESCRIPTION OF WORK**

The work to be done under this section of the Specifications and the accompanying plans consists of all labor, material, and equipment necessary to construct concrete sidewalks, driveways, and impressed concrete in the City of Fargo according to Municipal Code Article # 18-02 governing the construction of same, which is hereby made a part of this Specification. A copy of the article is attached at the end of this Specification for reference. For the purposes of these Specifications, alley returns shall be considered driveways, and all decorative/colored concrete behind curbs shall be considered impressed concrete.

**PART 2**  
**MATERIAL**

2.1. CEMENT

Cement shall conform to the requirements of Section 2100.

2.2. AGGREGATES

Fine and course aggregates shall conform to the requirements of Section 2100-2.2.

2.3. ADMIXTURES

Any admixtures shall conform to the requirements of Section 2100.

2.4. EPOXY RESIN ADHESIVE

Epoxy resin shall conform to the requirements of Section 2100.

2.5. CONCRETE PROPORTIONS AND PROPERTIES

One cubic-yard of mixed concrete in place shall contain not less than 517 lbs. of cement at a maximum water/cement ratio of 0.53. The slump shall not exceed four inches. Minimum 28-day compressive strength shall be 4,000 psi. Air content shall be targeted for 6% and shall fall between 5% and 8%.

2.6. REINFORCEMENT

Deformed reinforcing bars conforming to the Standard Specifications for Billet Steel Concrete Reinforcement Bars of the designation ASTM A615. Wire mesh reinforcement shall conform to the Standard Specification for Welded Steel Wire Fabric for Concrete Reinforcement of ASTM.

2.7. EXPANSION MATERIAL

Expansion joint material shall conform to ASTM D-1751 Type 5. It shall be 3/4 inch in thickness and shall have a width equal to the full depth of the slab in which it is to be used.

### 2.8. BASE AND BACKFILL MATERIAL

Base material under the concrete shall meet the gradation requirements of N.D. Class 5. Fill placed against the sides of the sidewalk shall be topsoil conforming to the requirements of Section 2000 of these Specifications.

### 2.9. FORMS

Forms shall be metal or wood free from warp and of sufficient strength to resist springing during the process of placing the concrete against them. Wood forms shall be at least 1 1/2 inch thick except for sharply curved sections where a flexible material shall be used with the Engineer's approval. Metal forms shall have a flat top and shall be of an approved section. Forms shall be of a depth equal to the sidewalk or driveway and shall be securely braced to retain the correct line and grade. Forms should be thoroughly cleaned and oiled or wetted before concrete is placed against them and be sufficiently tight to prevent mortar leakage between them.

### 2.10. STAMP

Stamp shall consist of letters 1 1/4 inches high and of sufficient depth to imprint the concrete to the depth of 1/8 inch. The stamp shall have the Contractor's name and the year of construction.

### 2.11. DETECTABLE WARNING PANELS

#### *2.11.1. CAST IRON PANELS*

Intended for use downtown and where specified by the Engineer in the plans. Panels shall be cast-in-place, powder-coated federal color FS 30166 (brick red), manufactured by East Jordan Iron Works, Neenah Foundry, or approved equal.

#### *2.11.2. ENGINEERED POLYMER COMPOSITE PANELS*

Intended for use on all projects where cast iron panels are not specified. Panels shall be cast-in-place, skid resistant, non-glare finished, and have a UV stable homogeneous integral color - federal color FS 33538 (safety yellow). Acceptable products are "Armor-Tile" as manufactured by Engineered Plastics, Inc., "Access Tile" as manufactured by Access Products, Inc., "Replaceable Wet-Set" as manufactured by ADA Solutions, Inc., or approved equal.

### 2.11.3. *TRUNCATED DOME CONFIGURATION*

The detectable warning panel shall consist of surface of truncated domes aligned in a square grid pattern.

Dome Size – Truncated domes in a detectable warning surface shall have a base diameter of 0.9 inches minimum to 1.4 inches maximum, a top diameter of 50% of the base diameter minimum to 65% of the base diameter maximum, and a height of 0.2 inches.

Dome Spacing – Truncated domes in a detectable warning surface shall have a center-to-center spacing of 1.6 inches minimum and 2.4 inches maximum, and a base-to-base spacing of 0.65 inches minimum measured between the most adjacent domes on the square grid.

Size – Detectable warning surfaces shall extend 24 inches in the direction of travel and the full width of the curb ramp landing.

Friction – Panels shall have a minimum coefficient of friction of 0.80.

### 2.12. *CURING COMPOUND*

All curing compounds shall conform to the requirements of AASHTO M 148 Type 2, and shall be applied in accordance with the manufacturer's recommendations.

#### 2.12.1. *SIDEWALKS AND DRIVEWAYS*

White pigmented in color.

#### 2.12.2. *IMPRESSIONED CONCRETE*

Transparent (no color).

**PART 3**  
**CONSTRUCTION**

3.1. ALIGNMENT AND GRADE

Prior to the construction or reconstruction of the sidewalk or driveway, the Contractor shall request the Engineer to set line and grade for the construction. Where necessary, the Engineer shall provide offset line stakes, which will be placed on each property corner and at interim intervals as necessary. Stakes will be offset and indicate the location and grade of the sidewalk or driveway to be constructed. Sidewalk shall have a 1/4-inch drop per foot across the width of the walk with the property side being higher than the street side.

3.2. EXCAVATION

The excavation for sidewalks, driveways, and impressed concrete shall be performed in a manner as to leave any finished lawn and boulevard in good condition and so as to protect any trees or shrubs adjacent to the work. The excavation shall be to a minimum depth of two inches below the bottom of the slab to be poured. If no excavation is required, all vegetation shall be removed in the area below the slab. No sidewalk subbase shall be constructed on any surface that is sloping to such an extent as to cause a future sliding or shifting of the finished work. Such slopes shall be benched or excavated to a horizontal plane before the subbase is constructed.

Excavated material not used at the site and not desired by the property owner shall be disposed of as directed by the City Engineer.

3.3. REMOVAL OF OLD SIDEWALK

Removal of old sidewalk will be required - the old concrete shall not be left in place beneath the new concrete. Removals shall be per Section 1050 of these Specifications.

3.4. REMOVAL OF CURBS FOR DRIVEWAYS

Existing curbs shall be removed for the construction of driveways. Removals shall be per Section 1050 of these Specifications.

### 3.5. PREPARATION OF THE SUBGRADE

All soft spongy spots or other unsuitable material shall be removed and replaced with suitable material and the subgrade compacted to a firm uniform surface.

### 3.6. PREPARATION OF THE SUBBASE

The aggregate subbase material shall be placed between the forms and compacted to a firm uniform surface by means of a hand tamper or vibratory compactor, then leveled off to the proper grade.

### 3.7. REINFORCING STEEL

All bars and/or mesh shall be clean and rust free and shall be supported at mid-depth by “chairs” of a type approved by the Engineer. All reinforcement bars shall be drilled into existing concrete a minimum depth of six (6) inches.

When drilling holes for placement of dowel bars and tie bars, an epoxy resin adhesive shall be used to anchor the bars in the drilled hole. The diameter of the drilled hole shall be as recommended by the epoxy manufacturer. In the absence of recommendations from the manufacturer, holes shall be drilled 1/8 to 1/4 inch larger than the diameter of the dowel bars and tie bars. The drilled holes shall be blown out with compressed air using a device that will reach to the back of the hole to ensure all debris and/or loose material is removed prior to epoxy injection.

Prior to insertion of the bars, drilled holes shall be filled with epoxy resin 1/3 to 1/2 full, or as recommended by the manufacturer. Each bar shall be rotated during installation to eliminate voids and to ensure complete bonding occurs. Bar insertion by the dipping method will not be allowed.

#### A. SIDEWALK AND IMPRESSIONED CONCRETE REINFORCEMENT

Two 3/8 inch deformed reinforcing bars shall be placed longitudinally for the full length of the sidewalk, said bars being placed one foot in from the edge of the form, and tied to the transverse bars. One 3/8 inch bar shall be placed one foot on either side of all expansion and contraction joints, said bar being 6 inches shorter than the width of the slab in which it is placed. Sidewalks over vaults or other openings shall be constructed to carry a load of not less than 250 pounds per square foot.



Reinforcement for sidewalk wider than 4 ½ feet shall be #3 bars at 24" on center. Welded wire mesh may be used on sidewalk wider than six feet in width. The wire mesh shall be cut into panels six inches smaller than the panel in which it is to be placed, but shall not extend through any contraction or expansion joint. Welded wire mesh shall be 6x6 W1.4/1.4 or heavier.

Two additional 3/8 inch reinforcement bars at least 10 feet long shall be placed in sidewalks over sewer and water trenches. Tie-ins to existing sidewalks shall have two 3/8" smooth bars drilled into the existing slab with a greased and capped end installed in the new sidewalk slab.

#### B. DRIVEWAY REINFORCEMENT

Reinforcement for driveways shall consist of #4 deformed bars spaced 24 inches on center both ways.

### 3.8. DIMENSIONS OF SLABS

Sidewalk shall be a minimum of 4 inches thick, residential driveways and alley returns shall be a minimum of 6 inches thick, and commercial and industrial driveways shall be a minimum of 7 inches thick. Sidewalk thickness shall be no less than the adjoining drive or 6 inches, whichever is greater, when located within a driveway section.

Sidewalks shall be a minimum of 4.5 feet wide and no sidewalk shall be reconstructed to a width less than that existing prior to reconstruction. Should occupancy of a commercial property change so as to substantially increase pedestrian traffic, the City Engineer shall require the sidewalk to be widened to conform to the sidewalks in the surrounding area.

Residential driveways shall be no less than 9 feet wide or more than 30 feet wide at the sidewalk line. Maximum width for commercial or industrial driveways is forty feet. Driveways shall be located so as to provide access to a parking location within the property served. Upon approval from the City Engineer, residential driveways may be constructed to a maximum 36-foot width or one-half the width of the lot. Locations of said driveways near block corners shall be approved by the City Engineer and shall be in accordance with the Fargo Land Development Code. In no case shall the aggregate width of a driveway into a property exceed one-half the lot width.

### 3.9. PLACING OF CONCRETE

All concrete shall be placed using formwork unless a mechanical paver is used. The subbase shall be moistened immediately prior to placing the concrete. The concrete shall be placed on the moist subbase and spread uniformly with as little handling as possible. The concrete shall be rough finished with a mechanically vibrated screed assembly and shall be spaded or vibrated with hand vibrators next to the forms to prevent voids or honeycomb surfaces.

### 3.10. CONTRACTION JOINTS

Contraction joints shall be constructed so as to divide the sidewalk into square slabs the greatest horizontal dimension of which shall not exceed 6 feet. All joints shall be saw cut on all sidewalk six feet or wider. Driveways shall have sawed contraction joints transversely spaced evenly between the crossing plate and the curb, not to exceed 8', and longitudinally spaced evenly across the driveway, not to exceed 12'. The contraction joints on sidewalk less than 6 feet wide shall be cut with a pointed trowel and edged to a radius of 1/2 inch, or sawed to a depth of 1/3 the depth of the slab within 24 hours of being placed.

### 3.11. EXPANSION JOINTS

Expansion joints in sidewalks shall be placed at 250-foot intervals, driveway edges, at every property corner and along existing curbs abutting the sidewalk or as directed by the Engineer. Greased 3/8" smooth bars shall be placed at mid-depth six (6) inches in from each sidewalk edge through the expansion joint. All expansion joints along curbs shall be 3/4 inch (shown on details) wide. All expansion joints shall be sealed with low modulus silicone sealant to produce a slightly concave surface approximately 1/4 inch below the concrete surface.

### 3.12. FINISHING

Immediately after placing, the concrete shall be floated down to a uniformly dense surface. The concrete surface shall have a slightly rough wood-float finish or a light broom finish. No apparent surface defects shall be allowed.

### 3.13. A.D.A. CURB RAMPS

Sidewalk curb approach ramps shall be constructed to current A.D.A. standards as detailed in the plans.

## A. DETECTABLE WARNING PANELS

All panels shall be installed according to the manufacturer's recommendations. Protective plastic shall be removed prior to opening the ramp to public use.

Dome Alignment – The rows of truncated domes in a detectable warning surface shall be aligned to be perpendicular to the grade break of the curb ramp.

Rail Crossings – The detectable warning surface shall be located so that the edge nearest the rail crossing is 6 feet minimum and 15 feet maximum from the centerline of the nearest rail. The rows of the truncated domes in the detectable warning surface shall be aligned with the direction of wheelchair travel.

## B. SLOPE

## 1) NEW CONSTRUCTION

Maximum slope shall be 1 foot vertical to 12 feet horizontal. Maximum rise for any run shall be thirty (30) inches or less.

## 2) RECONSTRUCTION

Curb ramps reconstructed where space limitations prevent the use of 1:12 slopes may have the following:

- a) Slopes between 10 and 12 to 1 are allowed a maximum rise of 6 inches.
- b) Slopes between 8 and 10 to 1 are allowed for a maximum rise of 3 inches.
- c) Slopes greater than 8 horizontal to 1 vertical are not allowed.

## 3) SIDE SLOPE

When curb ramps are located where pedestrians must walk across the ramp, the ramp shall have flared sides with a maximum slope of 1-foot vertical to 10 feet horizontal.

3.14. STAMPING

The Contractor shall stamp the name of his firm and year of construction into the fresh concrete on both sides of all expansion joints and at all termination points.

### 3.15. SIDE FILL REQUIRED

The Contractor will be required to backfill against the sides of the sidewalk and driveways to the top of the walk or drive and sloping away from the walk or drive at a grade no steeper than 1 foot vertical to 4 feet horizontal.

### 3.16. IMPRESSIONED CONCRETE

The Engineer will specify the concrete color and pattern in the plans and/or special instructions.

Reinforcing shall be per the sidewalk reinforcing Specifications above. Where impressed concrete abuts sidewalk, they shall be tied together with 12" long #3 deformed bars at 2' O.C.

Concrete finishing shall follow normal procedures for sidewalk except that the surface shall not be troweled more than once. After the surface is troweled or floated, and the concrete is still in a plastic stage, a pattern roller/stamp shall be used to obtain the specified pattern. The roller/stamp shall be placed so that the pattern is accurately aligned and to obtain a uniform depth of stamp of 5/16 inch. After rolling, a tool similar to a brick mason's jointer shall be used to dress the edges. Transverse and longitudinal joints shall be sawed in locations to match joints in abutting concrete or as determined by the Engineer.

Sandblasting shall be done by the Contractor to clean any colored concrete from the roadway and/or curb and gutter surfaces

Impressed concrete shall be 4 inches thick in medians and boulevards, and shall be 8 inches thick inside curb radii at intersections or as directed by the Engineer.

Refer to the standard details for thickened edge, expansion joint, and joint sealing requirements.

### 3.17. CURING AND PROTECTION OF SLABS

The Contractor shall cure the concrete by covering as soon as practicable with waterproof paper, plastic film, wet burlap, or by spraying with an approved curing agent. The Contractor shall erect suitable barriers, protected by warning lights to protect the work and the public. The Contractor is responsible for all damage and repair to the slabs. Sidewalks shall be closed to pedestrian traffic for a minimum of 24 hours and crossings and driveways shall be closed to vehicular for a

minimum of seven days. The Contractor shall use due care when removing the forms to avoid marring or damaging the fresh concrete.

3.18. COLD WEATHER POURING

When pouring concrete in cold weather, the provisions for cold weather pouring outlined in section 2100 of these Specifications shall apply.

3.19. WORKZONE SAFETY

Provisions protecting pedestrians and the traveling public in the workzone shall be employed in all cases per section 4100 of these Specifications.

**PART 4**  
**GUARANTEE, MEASUREMENT & PAYMENT**

4.1. GUARANTEE

The guarantee shall be per the contract.

4.2. MEASUREMENT AND PAYMENT

Payment will be full compensation for the excavation, subgrade and subbase preparation, furnishing and installing the aggregate base, concrete, reinforcing, expansion joints including sealant where specified, form work and all incidental labor, material, and equipment necessary to construct the sidewalks, driveways, and impressed concrete in accordance with these Specifications.

4.2.1. SIDEWALKS AND DRIVEWAYS

Sidewalks and driveways will be paid at the contract unit price per square yard.

4.2.2. CITY ORDER SIDEWALK

At the completion of each sidewalk constructed on city order, the Contractor shall measure the material and work involved, he shall then complete the estimate form provided, and shall forward the duplicate to the City Engineer for verification and payment.

4.2.3. A.D.A. CURB RAMPS

Payment for the curb ramp constructed shall be at the contract unit price for each of the following:

- A. Detectable Warning Panels – Panels shall be paid at the contract unit price per square foot.
- B. The remaining portion of the curb ramp shall be paid for under the 6” RC Sidewalk bid item at the contract unit price per square yard.

*4.2.4. IMPRESSIONED CONCRETE*

Impressioned Concrete will be paid at the contract unit price per square yard. Payment for impressioned concrete shall be made under the Impressioned Concrete bid item for the appropriate thickness. No adjustments will be made for thickened edges adjacent to curbs.

*4.2.5. OTHER COSTS*

All other costs for work necessary to properly complete the work specified herein shall not be bid items; the costs shall be charged to other items unless a bid item is specifically included on the bid sheet.

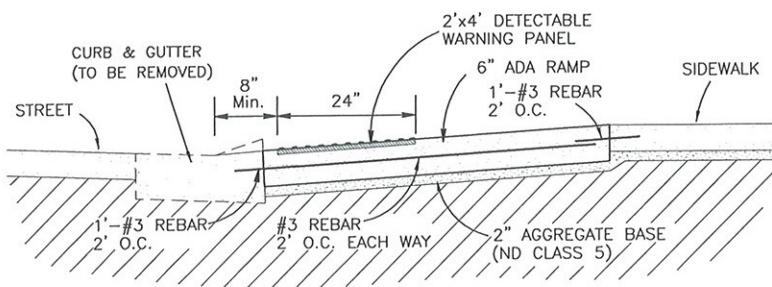
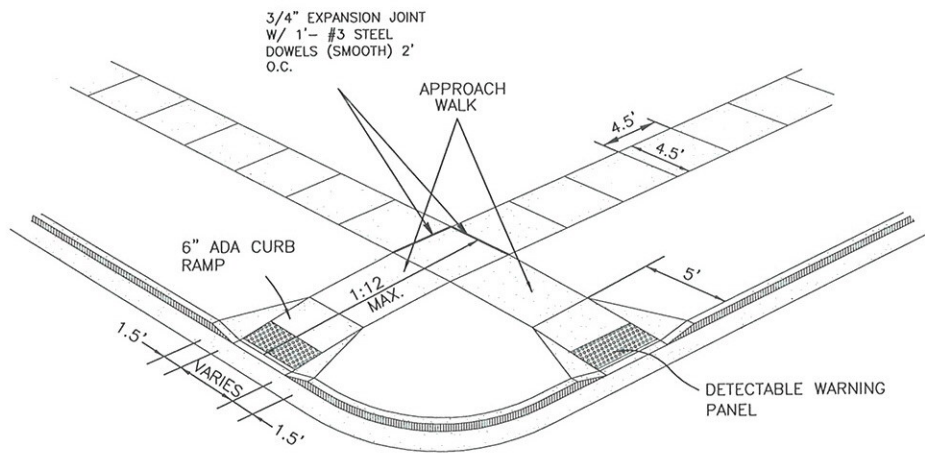
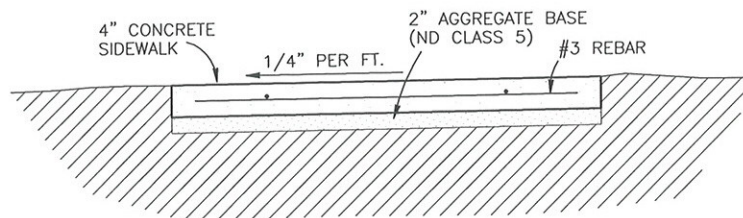
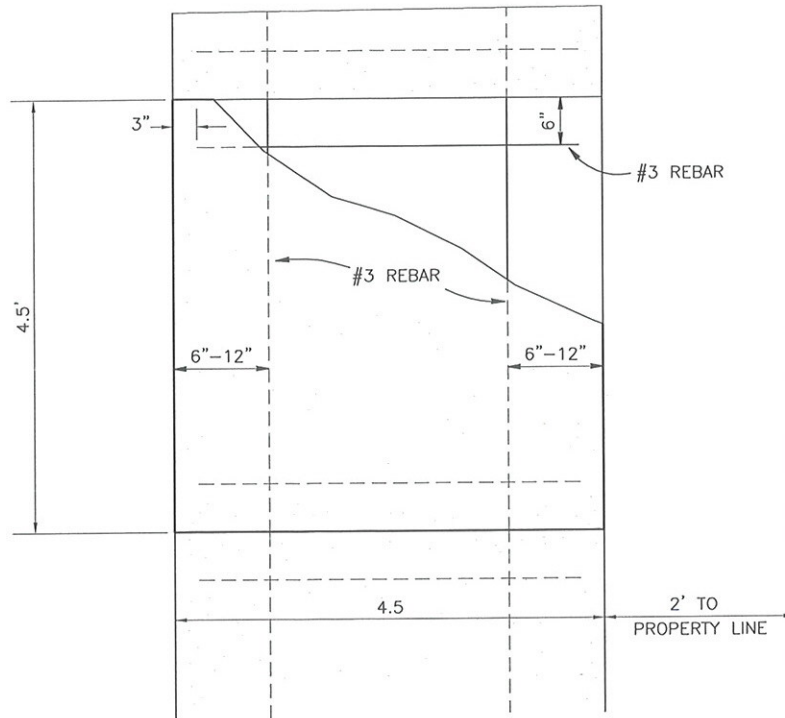

SECTION NO. 2300	DRAWING NO. 5.1
REV.D. 2013	
<b>SIDEWALK &amp; CURB RAMP DETAIL (4.5')</b>	
CITY OF FARGO ENGINEERING DEPARTMENT	
APPROVED <i>CME</i>	DATE 1-2-13



SIDEWALK WIDTH	PANELS (L'xW')
6'	5'x6'
8'	4.5'x4'
10'	5'x5'

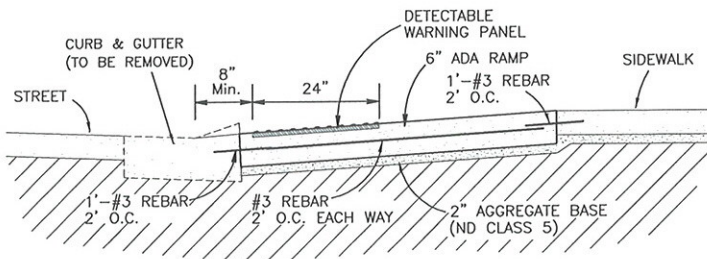
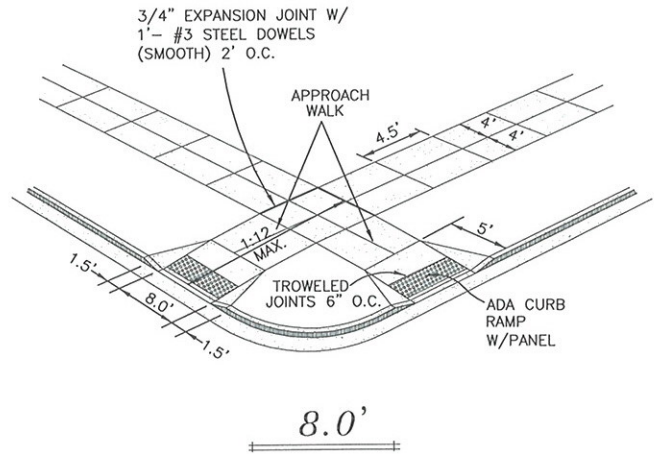
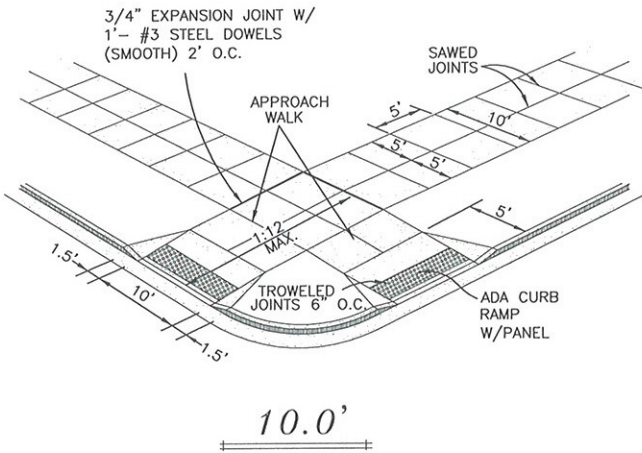
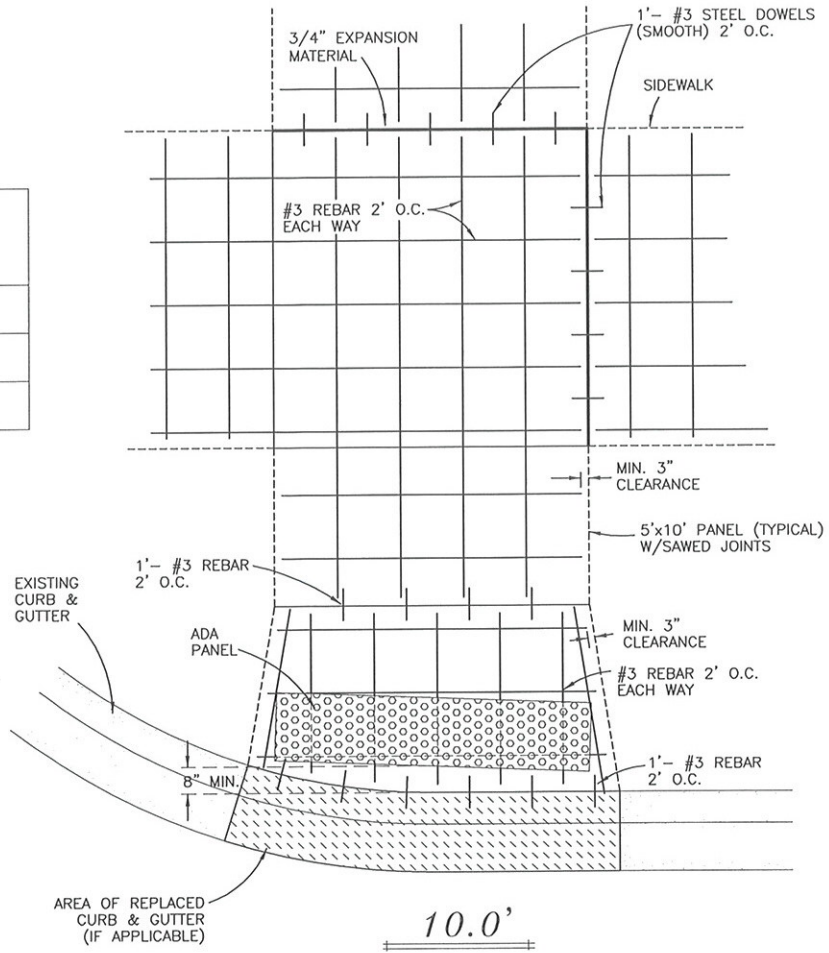

SECTION NO. 2300	DRAWING NO. 5.2
REV.D. 2013	
<b>SIDEWALK &amp; CURB RAMP DETAIL (6', 8', or 10')</b>	
CITY OF FARGO ENGINEERING DEPARTMENT	
APPROVED <i>CME</i>	DATE 1-2-13

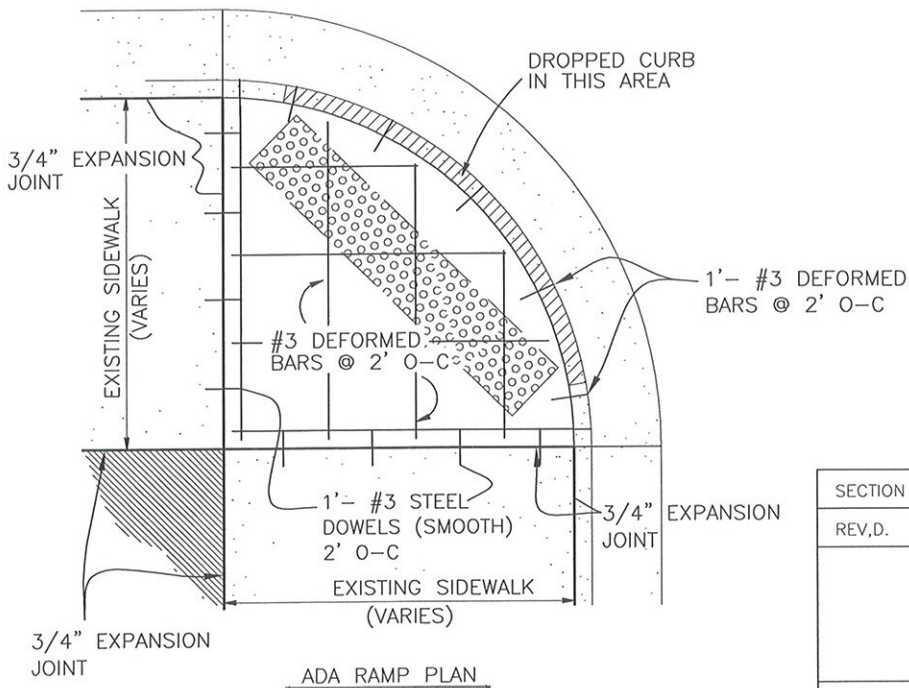
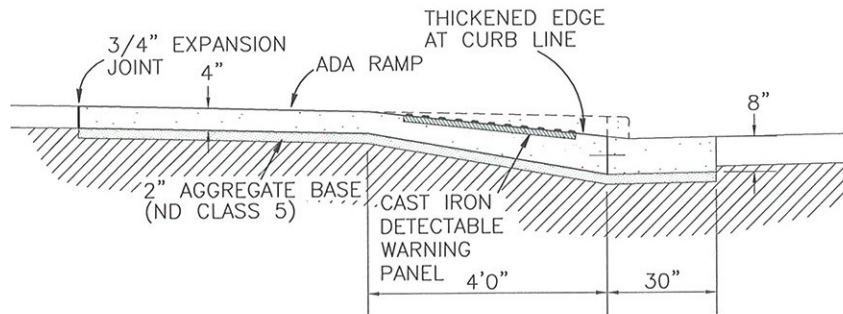
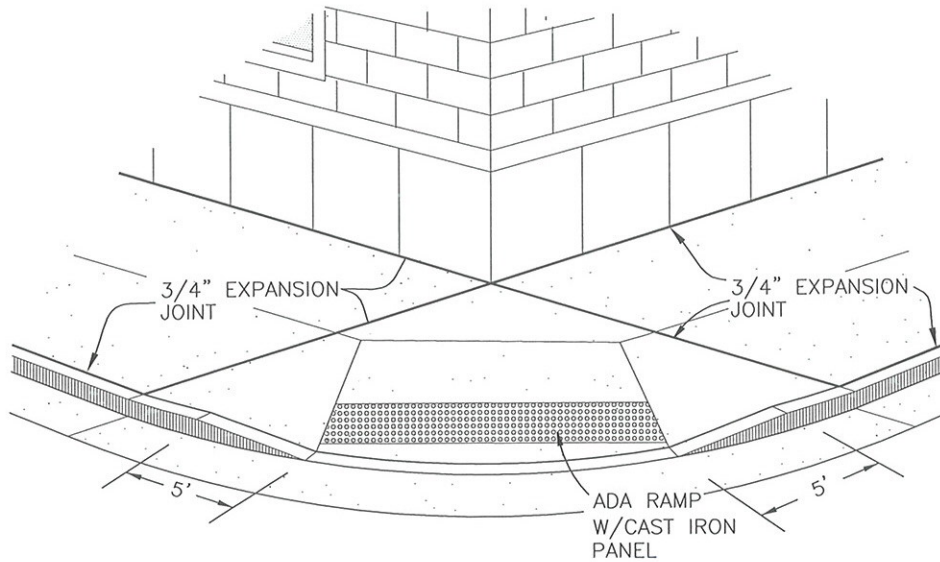

SECTION NO.	2300	DRAWING NO.	5.3
REV.D.	2013		
<b>ADA RAMP DOWNTOWN AREA</b>			
CITY OF FARGO ENGINEERING DEPARTMENT			
APPROVED	<i>CME</i>	DATE	<i>1-2-13</i>

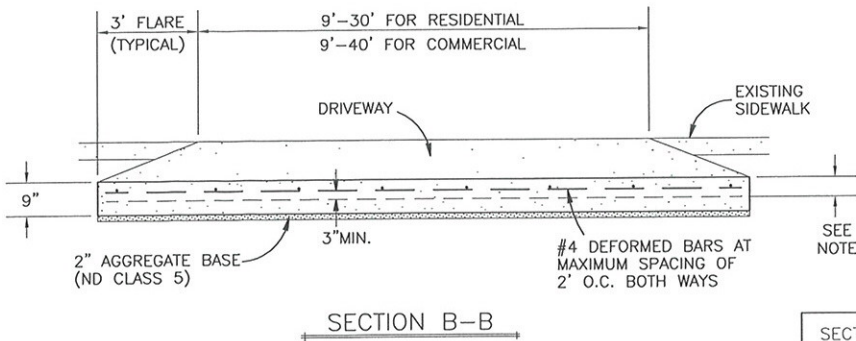
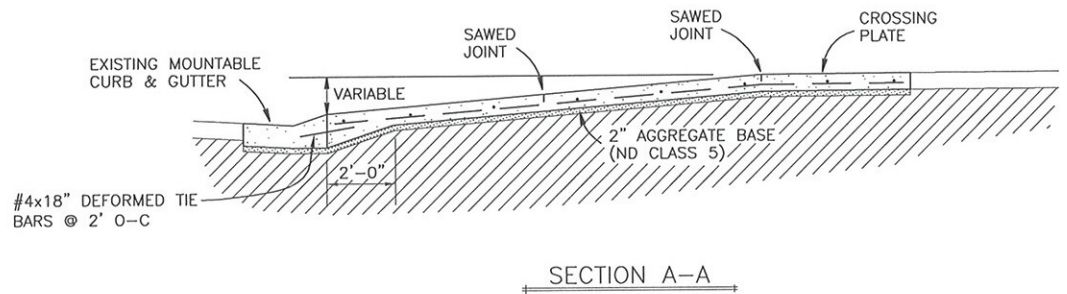
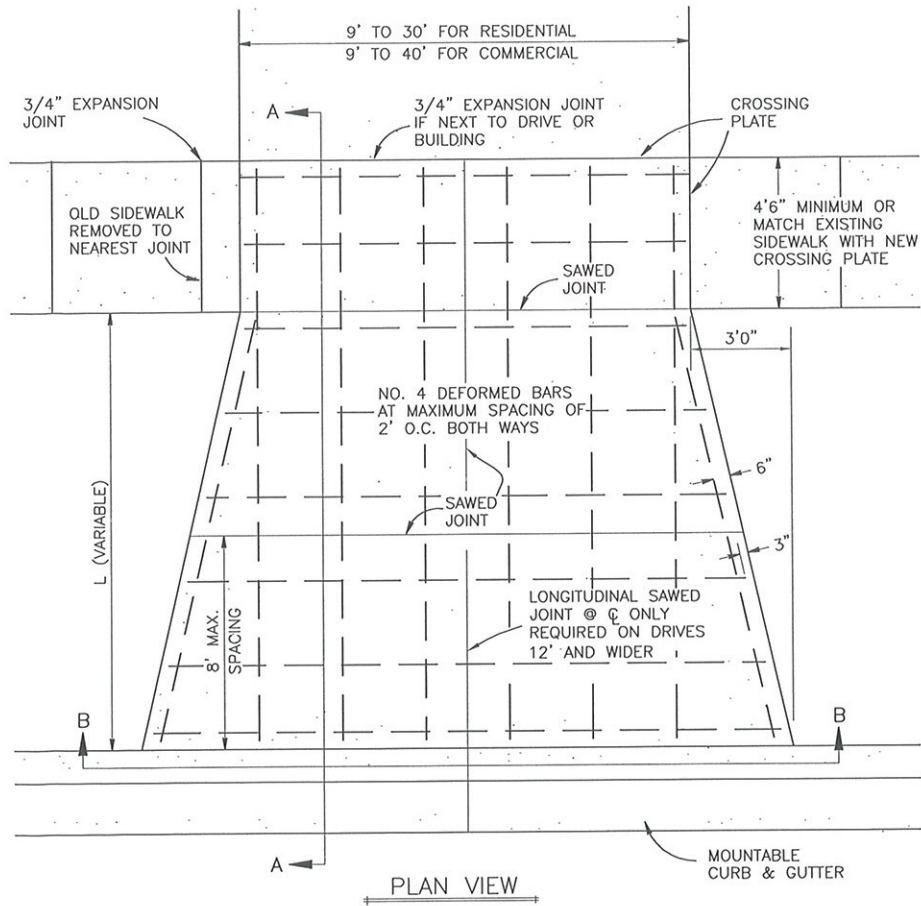

- NOTES:
1. MIN. THICKNESS OF DRIVEWAYS SHALL BE:  
6" FOR RESIDENTIAL  
7" FOR COMMERCIAL AND INDUSTRIAL
  2. JOINT SPACINGS: THE DRIVEWAY LONGITUDINAL JOINT SPACING SHALL MATCH CURB AND GUTTER OR CONCRETE PAVEMENT JOINT SPACING. THE DRIVEWAY TRANSVERSE JOINT SPACING SHALL NOT EXCEED 8' SPACING.
  3. SAW DEPTH: THICKNESS/4 + 1/4"

SECTION NO. 2300	DRAWING NO. 5.4
REV.D. 2013	
<b>STANDARD PRIVATE DRIVE ABUTTING MOUNTABLE CURB</b>	
CITY OF FARGO ENGINEERING DEPARTMENT	
APPROVED <i>OME</i>	DATE 1-2-13



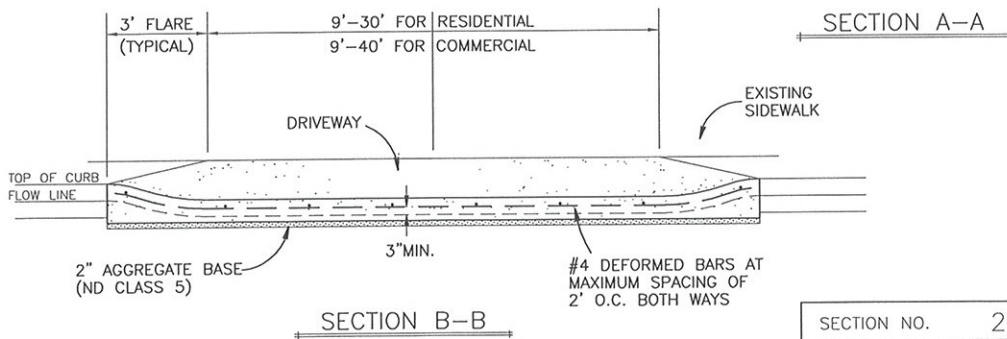
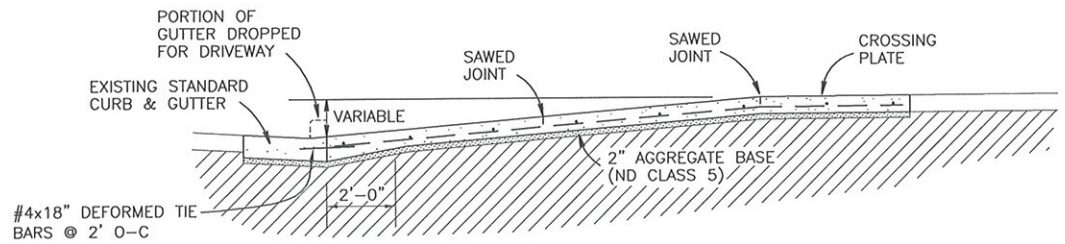
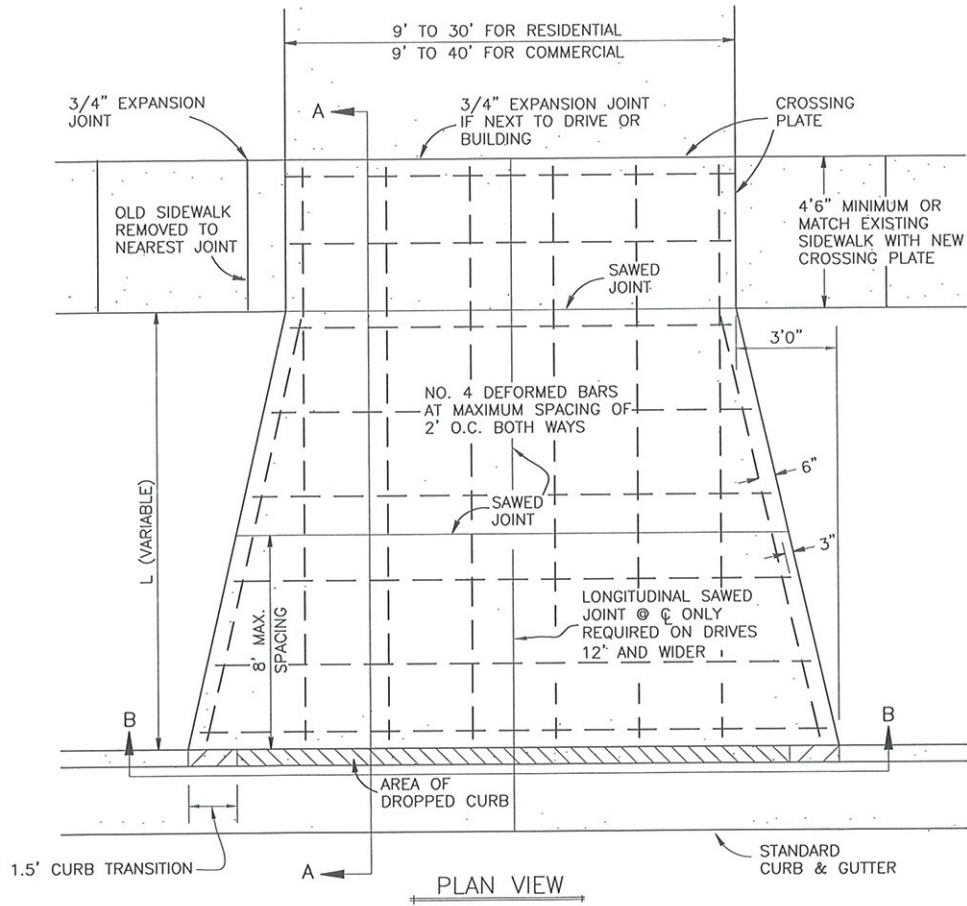

- NOTES:
1. MIN. THICKNESS OF DRIVEWAYS SHALL BE:  
6" FOR RESIDENTIAL  
7" FOR COMMERCIAL AND INDUSTRIAL
  2. JOINT SPACINGS: THE DRIVEWAY LONGITUDINAL JOINT SPACING SHALL MATCH CURB AND GUTTER OR CONCRETE PAVEMENT JOINT SPACING. THE DRIVEWAY TRANSVERSE JOINT SPACING SHALL BE EVENLY SPACED BETWEEN THE CROSSING PLATE AND CURB, NOT TO EXCEED 8' SPACING.
  3. SAW DEPTH: THICKNESS/4 + 3/4"

SECTION NO. 2300	DRAWING NO. 5.5
REV.D. 2013	
<b>STANDARD PRIVATE DRIVE ABUTTING STANDARD CURB</b>	
CITY OF FARGO ENGINEERING DEPARTMENT	
APPROVED <i>CME</i>	DATE 1-2-13

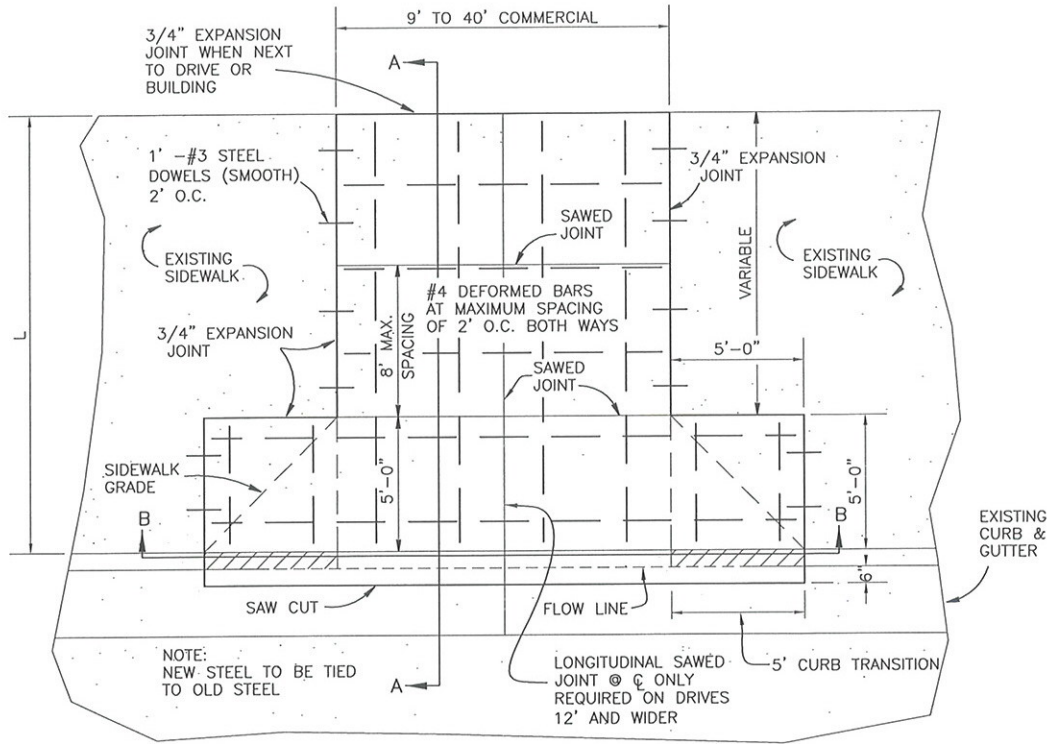

PLAN VIEW

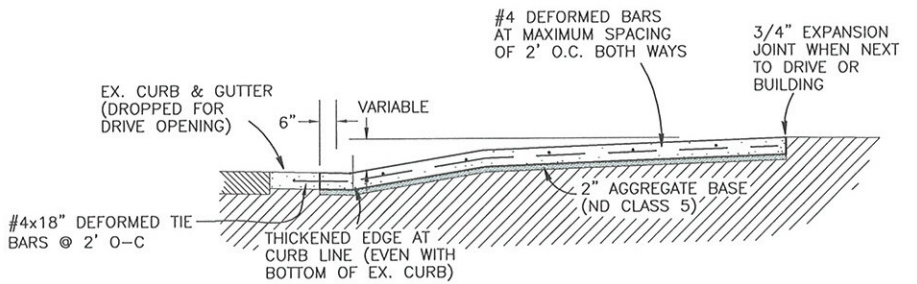

SECTION A-A

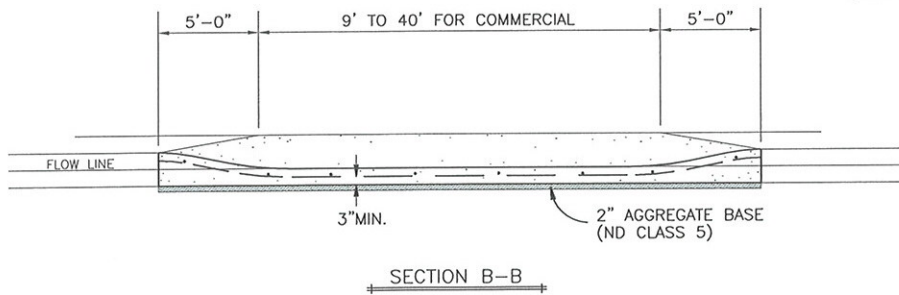

SECTION B-B

- NOTES:
1. MIN. THICKNESS OF DRIVEWAYS SHALL BE:  
6" FOR RESIDENTIAL  
7" FOR COMMERCIAL AND INDUSTRIAL
  2. JOINT SPACINGS: THE DRIVEWAY LONGITUDINAL JOINT SPACING SHALL MATCH CURB AND GUTTER OR CONCRETE PAVEMENT JOINT SPACING. THE DRIVEWAY TRANSVERSE JOINT SPACING SHALL MATCH EXISTING SIDEWALK JOINTS.
  3. SAW DEPTH: THICKNESS/4 + 1/4"

SECTION NO. 2300	DRAWING NO. 5.6
REV.D. 2013	
<b>RETROFIT PRIVATE DRIVE W/FULL SIDEWALK</b>	
CITY OF FARGO ENGINEERING DEPARTMENT	
APPROVED <i>OME</i>	DATE 1-2-13

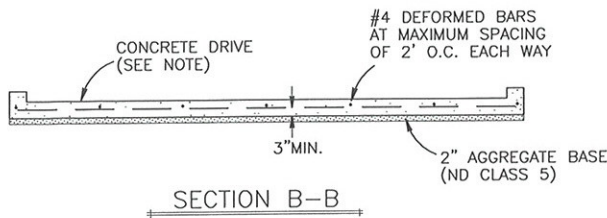
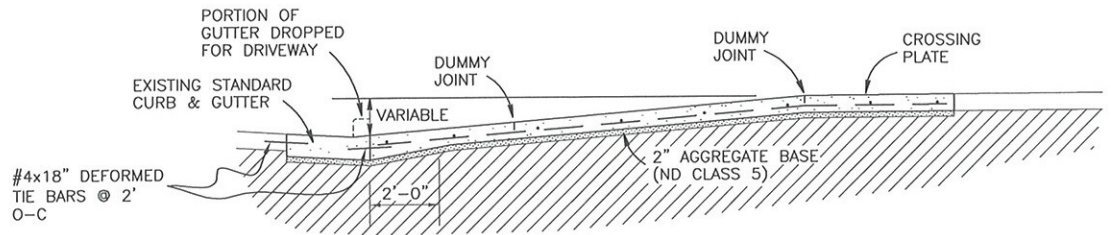
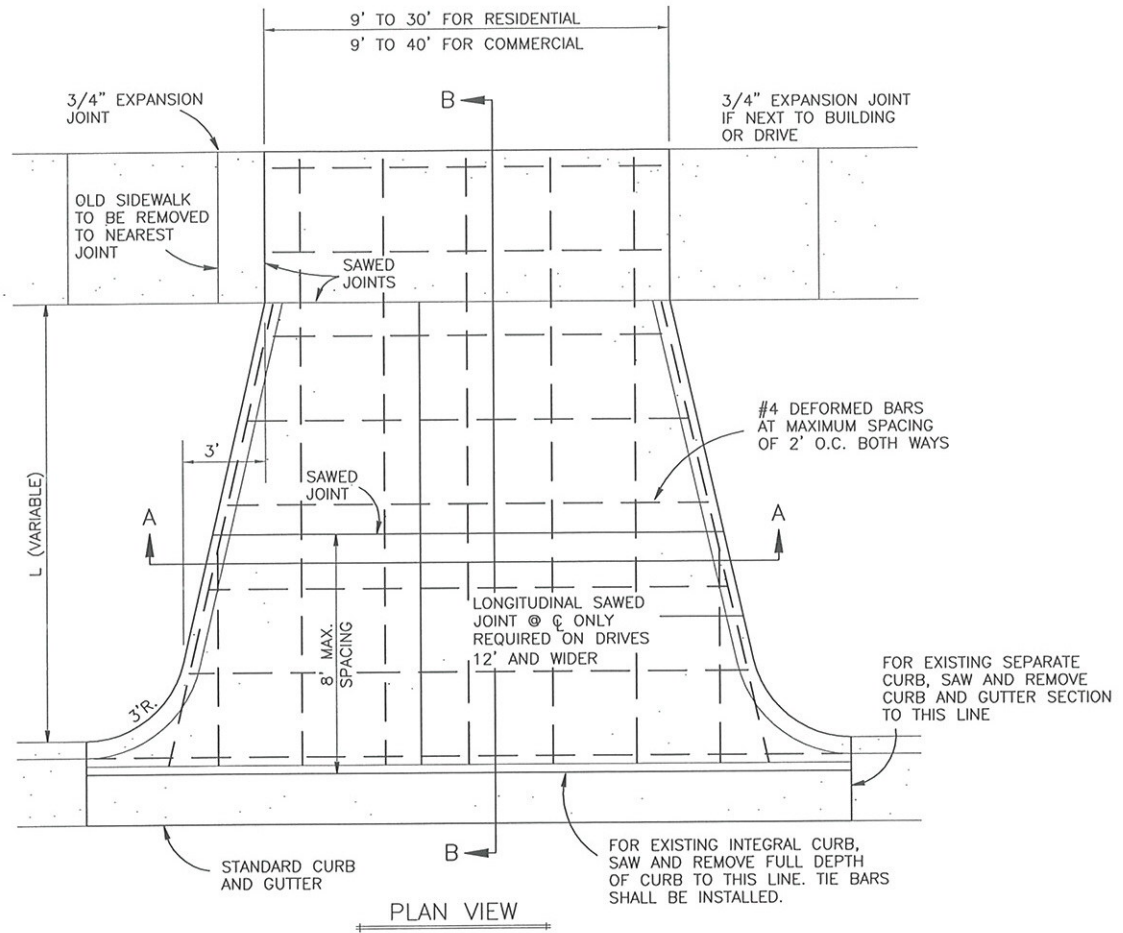

**NOTES:**

1. MIN. THICKNESS OF DRIVEWAYS SHALL BE:  
6" FOR RESIDENTIAL  
7" FOR COMMERCIAL AND INDUSTRIAL
2. JOINT SPACINGS: THE DRIVEWAY LONGITUDINAL JOINT SPACING SHALL MATCH CURB AND GUTTER OR CONCRETE PAVEMENT JOINT SPACING. THE DRIVEWAY TRANSVERSE JOINT SPACING SHALL BE EVENLY SPACED BETWEEN THE CROSSING PLATE AND CURB, NOT TO EXCEED 8' SPACING.
3. SAW DEPTH: THICKNESS/4 + 1/4"
4. THIS DRIVEWAY DETAIL NOT TO BE USED FOR NEW CONST. UNLESS SPECIFICALLY DIRECTED BY THE ENGINEER.

SECTION NO. 2300	DRAWING NO. 5.7
REV.D. 2013	
<b>STANDARD PRIVATE DRIVE ABUTTING STANDARD CURB</b>	
CITY OF FARGO ENGINEERING DEPARTMENT	
APPROVED <i>CME</i>	DATE 1-2-13

**CITY OF FARGO SPECIFICATIONS  
ASPHALT PAVING**

**PART 1  
DESCRIPTION OF WORK**

The work to be done under this section of the Specifications and the accompanying plans consists of furnishing all labor, material, accessories, and plant necessary to complete the asphalt paving of certain streets, avenues or alleys in the City of Fargo.

Excavation, filling, and subgrade preparation shall be in accordance with Section #2000. The work under this section of the Specifications shall also include the cleaning, drying and preparing the existing surface and the laydown of the bituminous material, rolling, adjusting manholes and valve boxes to grade, and all other work as may be necessary to properly complete the asphalt base course, wear course, and leveling course work in accordance with these Specifications and the accompanying plans.

**PART 2  
MATERIALS**

All materials shall be obtained from approved sources. The materials used in connection with this work shall all conform to the latest revision of the applicable ASTM standard.

2.1. ASPHALT CEMENT

Asphalt cement shall be Performance Graded Asphalt Cement meeting the requirements of AASHTO MP1, PG 58-28 unless otherwise specified.

2.2. TACK COAT

The tack coat shall meet NDDOT requirements for tack coat. The tack coat to be used on any job shall be subject to the approval of the Engineer. Care shall be taken to prevent asphalt emulsions from freezing. Proper storage and handling techniques shall be used to prevent the asphalt emulsion from separating or breaking. Any emulsion that has separated or broken shall be rejected, and immediately removed from the jobsite. Emulsified asphalt for tack shall be diluted adequately to allow uniform spray application.

2.3. AGGREGATES

Aggregates shall be in accordance with Section 430 of the NDDOT Standard Specifications for Road and Bridge Construction, except gradations for leveling courses shall be as follows:

<u>Sieve Size</u>	<u>% Passing by Weight</u>
1/2"	100%
3/8"	85-100%
#4	50-80%
#10	35-65%
#30	25-45%
#100	5-20%
#200	3-10%
Maximum Shale and Soft Rock	4%
Maximum Clay	5%
Maximum Loss (L. A. Abrasion Test)	40%



#### 2.4. SUPERPAVE MIX PROPERTIES AND RECYCLED ASPHALT PAVEMENT (RAP)

Superpave mix properties and RAP (if used) shall be in accordance with Section 430 of the NDDOT Standard Specifications for Road and Bridge Construction. The Superpave mix shall be FAA 43 unless otherwise specified.

#### 2.5. WARM MIX ASPHALT AND ADMIXTURES

##### *2.5.1 WARM MIX ASPHALT (WMA)*

WMA technology may be used at the discretion of, and at no additional compensation to, the Contractor. Approved technologies for WMA include chemical additive and foaming processes (either by additive or mechanical means). Other methods must be approved by the Engineer prior to use.

If WMA is used, all manufacturers' recommendations for incorporating WMA technology into the mix shall be followed. All requirements in the Standard Specifications for the production and placement of conventional Hot Mix Asphalt mixtures are to be enforced except as noted herein. Prior to the use of WMA, the minimum plant mixing, delivery, placement and compaction temperatures that will achieve workability and density requirements shall be submitted by the Contractor to the Engineer. The Engineer may suspend or eliminate the use of WMA on the project if any of the following conditions occur: rutting, segregation, surface voids, tearing, irregular surface, low density, raveling, stripping, or if pavement does not meet any other design criteria.

WMA mixtures using the foaming process must include a moisture sensitivity analysis, AASHTO T 283, on plant produced mix using the foaming process. The moisture sensitivity analysis shall be conducted the first day of plant production on the project to ensure the foaming process is not detrimental to the moisture resistance of the mixture. AASHTO T 283 gyratory specimens will be compacted to  $7.0 \pm 1$  percent air voids. A Tensile Strength Ratio (TSR) value of 70 min. is required. If TSR values are low, the addition of lime or anti-strip agents to the mix will be required to meet the minimum TSR value. The degree of particle coating of the plant produced WMA mixture must be determined according to AASHTO T 195. AASHTO T 195 is a field test for visually determining whether the asphalt plant is properly producing WMA that is sufficiently coated with asphalt cement. A WMA mixture with percent coated particles  $\geq 95.0$

percent is required. Increasing the plant mixing time or making other plant adjustments may be necessary if the percent of coated particles is not met.

All costs associated with completing the moisture sensitivity analysis and providing the results to the Engineer along with all manufacturers' recommendations for the WMA technology shall be included in the price bid for other items.

### 2.5.2 ADMIXTURES

Admixtures for warm mix asphalt and cool weather paving shall be in accordance with NDDOT requirements.

Whenever an admixture is used, the admixture manufacturer's name and dosage rate and any changes to the original job mix formula must be submitted to the Engineer in the field prior to use. The admixture shall have no special handling requirements above and beyond those of the binder itself. If the admixture is added by the supplier or refiner, the admixture shall be added to the binder according to the admixture manufacturer's recommendations. If the admixture is added by the Contractor at the asphalt plant, the admixture shall be added according to the admixture manufacturer's recommendations and the plant shall be equipped with a metering device that records the rate of admixture application.

2.6. WATERTIGHT MANHOLE SEALS / CHIMNEY BARRIERS

Internal and external manhole chimney seals shall be as manufactured by Cretex Specialty Products, NPC, Inc. or approved equal. The sealing bands and all mounting hardware (screws, bolts, nuts, etc.) shall be Type 304 stainless steel.

Manhole chimney barriers shall be a molded polymer seal, designed to be incorporated into the chimney section of a manhole assembly, manufactured from medium density polyethylene as defined by ASTM designation D 1248, and have the following properties:

<u>PROPERTY</u>	<u>TEST METHOD</u>	<u>VALUE</u>
Melt Index	ASTM D-1238	4.5
Density	ASTM D-792	.938
Tensile strength at yield, psi	ASTM D-638	2800
Elongation at break, %	ASTM D-638	400
Flexural Modulus, tangent, psi	ASTM D-790	115,000
ESCR ASTM	D-1693	1000
UL-94 @ .060 & @ .120 thickness	UL-94	HB
Deflection Temp, 88 psi, °C	D-648	83
Deflection Temp, 264 psi, °C	D-648	42
Low Temp Impact, -40°C, ft-lb	ARM	68

2.7. EQUIPMENT

All equipment shall be in accordance with Section 430 of the NDDOT Standard Specifications for Road and Bridge Construction.

**PART 3**  
**CONSTRUCTION**

3.1. MIX DESIGN AND TESTING

The mix design(s) shall be in accordance with Section 430 of the NDDOT Standard Specifications for Road and Bridge Construction.

Although nuclear density tests may be performed by the Engineer to verify densities, the Contractor is responsible for the quality of the finished product and should perform tests accordingly at his own expense.

The Engineer may, at his discretion, require the Contractor to submit representative samples of the materials he proposes to use prior to the delivery of the materials to the site of the work, and may, during the progress of the work, take samples and make tests to assure that the work is being performed in accordance with these Specifications. The Contractor shall cooperate in the making of such tests to the extent of allowing free access to the work, for the selection of samples.

Samples shall be obtained and tested in accordance with the latest ASTM methods of tests.

3.2. PREPARATION OF EXISTING SURFACE TO BE PAVED

*3.2.1 AGGREGATE BASE*

See Section 2070 of these Standard Specifications. Any unstable areas shall be repaired prior to beginning paving operations.

*3.2.2 EXISTING PAVEMENT*

All loose, pocketed, caked, or other deleterious material shall be removed from the existing pavement. Flushing or sweeping with hand or power brooms will be acceptable methods of cleaning the pavement.

On wear course and overlay projects, all depressions, dips, and cupped cracks in the existing pavement shall be filled by the use of a motor grader, tractor with bucket, or hand methods and well compacted before the asphalt overlay is applied with the bituminous paver. On certain streets where the centerline has settled, it may be necessary

to install a thin lift down the centerline of the section with the paver straddling that centerline.

### 3.3. TEMPERATURE AND WEATHER LIMITATIONS

Asphalt mix shall not be placed on a visibly wet surface, on a frozen roadbed, or when weather conditions prevent the proper handling or finishing of the mixtures. Presence of frost particles in the roadbed is sufficient evidence of being frozen.

For construction of base courses, the air temperature shall be at least 40° F and rising. For construction of wear courses and leveling courses, the air temperature shall be at least 45° F and rising. Paving outside these temperature limitations will require the Contractor to include in the mix an admixture for cool weather paving conforming to Section 2.5 above.

In any case, paving will only be allowed when the air and surface temperature are at least 33° F.

### 3.4. TACK COAT

Prior to paving a wear course, overlay, or subsequent lift of bituminous base course, a tack coat shall be applied to the existing surface. All contact surfaces of manholes, gutters, headers, etc. shall be painted with a thin uniform coating of tack oil prior to placing the asphalt mixture against them. The surfaces shall be clean and dry. The minimum application temperature shall comply with the latest recommendations of the asphalt institute. The target application rate of the tack oil shall be 0.05 GAL/SY for subsequent lifts, and closer to 0.10 GAL/SY for overlays of aged pavements unless otherwise directed by the Engineer.

### 3.5. BITUMINOUS MAT

The base course shall be a “lean” mix and the wear course shall be a “rich” mix. The target percent of oil and Maximum Theoretical Density of the mix shall be determined by the mix design submitted prior to the Contractor’s first project of the year. The mix shall be promptly transported to the site by trucks with tight, clean, boxes lubricated with an Engineer-approved release agent, that have been properly weighed on an approved platform scale.

The mix shall be spread by an approved paving machine as soon as possible after arriving at the site and before the mixture cools to an unworkable consistency. For hot mix, the minimum laydown temperature is 225° F for base and wear courses, and 275° F for leveling courses. Hand methods may be used in inaccessible areas. When the mixture is spread by hand, loads shall not be dumped any faster than can be properly distributed. The raking shall be skillfully and carefully done in such a manner that after the first pass of the roller, minimal back patching will be required.

Maximum lift thickness for base course shall be 3 1/2 inch compacted; maximum lift thickness for wear course shall be 2 1/2 inch compacted. Adequate allowance shall be made for compaction in the spreading of the mixture. Longitudinal and transverse joints shall be well bonded and sealed. If necessary to obtain this result, the joints shall be cut back to the full depth of the previously laid course, painted with hot asphalt, and heated. All tack oil shall be applied prior to placing the asphalt mixture.

Immediately after the bituminous mixture has been spread, struck off, and surface irregularities corrected, it shall be thoroughly compacted by rolling. Compaction shall consist of the initial or breakdown rolling, intermediate rolling, and finish rolling. Rolling shall start as soon as the mixture will not unduly displace, rack or shove. Rolling shall begin at the sides of the road and work towards the crown. Mix along curbs shall be compacted by pinching the mix between the roller tire and the curb. Along forms, headers, walls and inaccessible areas, the mixture shall be compacted by mechanical tampers. Rolling shall proceed until all roller marks have been eliminated and densities of approximately 3-5 % air voids have been obtained. Compaction shall be by the NDDOT Ordinary Compaction method except as modified herein. Where nuclear density tests are taken, the average density shall be 90% or greater of the Maximum Theoretical Density (MTD).

Any areas that are under-compacted, become loose and broken, mixed with dirt, or defective in any way shall be removed and replaced with fresh hot mixture at the Contractor's expense.

### 3.6. OPENING TO TRAFFIC

Under the most favorable conditions for paving, the pavement shall be closed to traffic for at least 6 hours, and in warm weather for an additional time to be determined by the Engineer. The Contractor shall erect and maintain suitable barricades and lights to protect the pavement from traffic. Any part of the pavement damaged from traffic or other causes occurring prior to the acceptance of the pavement shall be repaired by the Contractor at his own cost and to the satisfaction of the Engineer.

The Contractor shall receive written notice from the Engineer to open the pavement to traffic and shall then dispose of all covering material as directed and remove all barricades.

### 3.7. LOCATION OF EXISTING UTILITIES

Existing manholes, gate valve boxes, and stop boxes have been shown to direct the Contractor's attention to their existence. The Contractor is cautioned that not all utilities have been shown and their location is not guaranteed. The Contractor is responsible for determining the exact location of existing utilities that affect the installation of the paving.

Prior to paving, the Contractor shall locate and mark all manholes and valve boxes that will be affected by the paving operation. Marking shall be accomplished using a marking device capable of showing the exact location of the center of the manhole or valve box after paving. In addition, all manholes and gate valves shall be double-tied to fixed objects outside the paving area. A copy of the tie sheets shall be given to the Engineer prior to paving.

### 3.8. WATERTIGHT MANHOLE SEALS / CHIMNEY BARRIERS

A watertight manhole seal or chimney barrier shall be installed on each sanitary sewer manhole not located in the street at the time of its final adjustment to grade.

Where chimney barriers are used, the bottom surface of the barrier flange shall be sealed to the manhole cone top surface using a butyl sealant as specified by the barrier manufacturer. The sealant shall be applied to the top surface of the manhole cone section only. The amount of sealant and its placement will be dependent on the condition of the cone. Sufficient sealant shall be used to accommodate flaws in the cone surface and "out-of-flat" conditions. The barrier shall then be centrally seated on the cone against the sealant. The bottom adjustment ring shall be centrally placed on the top surface of the barrier flange using no sealant. If plastic adjustment rings with a vertical tongue are being used, the tongue shall be cut off in accordance with the ring manufacturer's recommendations to allow the bottom ring to rest flush on the barrier flange.

Where internal seals are used, the sealing surface shall be clean and free of loose material and excessive voids. If the surface has minor irregularities, a bead of butyl-rubber caulking shall be applied to fill these voids. If the sealing surface is rough or has excessive voids, a low-shrink mortar sealing surface shall be installed. Any flanges or protrusions on the interior to the casting shall be removed and ground smooth. Seals shall be installed to a water-tight condition.

Where external seals are used, the Contractor shall install the seal in accordance with the manufacturer's recommendations. The exterior of the manhole and casting shall be wire-brushed clean, leveled and smoothed with a low-shrink mortar surface if necessary. Seals shall be installed to a water-tight condition.

### 3.9. CASTING TO GRADE (WITH CONCRETE, NO CONCRETE)

This item includes all labor, materials and equipment necessary to adjust the various manhole castings to the proper line and grade. For manholes located in the street on all wearing course projects and where specified by the Engineer, the Contractor shall center the adjusted casting in a min. 5.0' x 5.0' reinforced concrete square at an elevation level with the final wear course grade.

Changes in grade shall be made as follows:

All adjustments, including fine adjustments, shall be made with adjustment rings specified in Section 1500 of these Specifications. All adjustment rings shall be properly sealed in accordance with the manufacturer's recommendations and as follows: For storm sewer manholes/inlets, rings shall either be sealed watertight or be wrapped with nonwoven geotextile fabric, secured around the outside of the rings from three (3) inches below the top of the manhole/inlet structure to the top of the rings, overlapping the frame casting. For sanitary sewer manholes, rings shall be sealed water-tight from the frame casting to the manhole structure. In lieu of the use of an adhesive/sealant, an external mechanical frame-chimney seal may be used for a watertight installation.

Where casting adjustment requirements cannot be met by the use of engineered polymer adjustment rings and upon the Division Engineer's approval, the Contractor shall provide precast reinforced concrete adjusting rings. For fine adjustments of less than two (2) inches, steel shims shall be used to temporarily support the casting. The castings and rings shall be laid in a full bed of mortar. The rings and structure section shall be cleaned to assure a flat seating surface and the rings shall be installed in alignment with no noticeable offsets. A four (4) inch wide concrete encasement shall be placed around the outside of the rings from three (3) inches below the top of the structure to the frame casting.

Care shall be taken to adjust the casting to the proper grade so the final riding surface is smooth and free of bumps and it conforms to the alignment and grade of the adjoining asphalt. Any



castings not satisfying these requirements shall be redone to the satisfaction of the Engineer. Castings shall be set flush to the pavement surface.

The casting to grade item includes cleaning all construction debris and dirt from the manhole or inlet bottom and installing a wiped mortar finish around the inside and outside circumference of the precast concrete adjusting rings. Where encountered, existing watertight manhole seals shall be salvaged and replaced by the Contractor at no additional compensation. Where chimney barriers are installed or encountered, the gap between the barrier and the adjusted casting shall be filled with spray foam or other Engineer-approved material.

3.10. CASTING TO GRADE – (OVER DEPTH)

This bid item applies where more than 4 rings are required to make a casting adjustment, and shall include all labor, materials, and equipment necessary to make the adjustment in addition to the work described in Casting to Grade above.

3.11. CASTING TO GRADE (BOULEVARD)

This bid item shall be in accordance with either Section 1200 or 1500 of these Specifications, as applicable.

3.12. VALVE BOXES TO GRADE

This item shall include all labor, material, and equipment necessary to raise or lower valve boxes to the proper line and grade, including cleaning. Where called for on the plans and/or where specified by the Engineer, the Contractor shall center the gate valve box in a min. 3.0' x 3.0' reinforced concrete square at an elevation level with the final wear course grade.

Adjustments shall be made by turning the valve box up or down with a wrench. The use of adjusting rings will only be allowed when the top section of the valve box has already been turned up to its limit. Care shall be taken to adjust the valve box to the proper grade so the final riding surface is smooth and free of bumps and that it conforms to the grade of the adjoining pavement. Valve boxes shall be set flush with the finished pavement surface. Any valve boxes not satisfying these requirements shall be redone to the satisfaction of the Engineer.

The gate box to grade item also includes cleaning all debris and dirt from the box, ensuring that the box is straight and undamaged, and ensuring that the valve is operable.

**PART 4**  
**GUARANTEE, MEASUREMENT & PAYMENT**

4.1. GUARANTEE

The guarantee shall be per the contract.

4.2. MEASUREMENT AND PAYMENT

Payment for all items shall be full compensation for all labor, material, equipment and miscellaneous items necessary for constructing these items in place.

*4.2.1. DETERMINATION OF AMOUNT OF ASPHALT CEMENT USED*

Quantities of asphalt cement in the mix will be determined by asphalt extractions taken by an independent testing laboratory. The conversion factor used will be 8.6 pounds per gallon.

*4.2.2. DETERMINATION OF COMBINED AGGREGATE*

The total weight for the bituminous mix shall be determined by the wet ton of material in trucks on an approved platform scale. The total weight of asphalt cement, as determined in part 4.2.2, shall be deducted from the total weight of the mix to determine the dry weight of the combined aggregate in tons.

*4.2.3. METHOD OF PAYMENT*

## A. EXCAVATION AND SUBGRADE PREPARATION

Paid under Section #2000 contract bid items.

## B. COMBINED AGGREGATE (DRY WEIGHT)

Paid for at the contract unit price per ton.

## C. ASPHALT CEMENT

Paid for at the contract unit price per gallon.

## D. ASPHALT MIX (INCLUDES ASPHALT CEMENT)

If the asphalt base course, wear course, or overlay is bid as containing the asphalt cement, the payment will be based on the wet tonnage, and there will be no adjustment for the aggregate or asphalt cement.

## E. WATERTIGHT MANHOLE SEALS / CHIMNEY BARRIERS

Watertight seals and chimney barriers shall be paid for at the contract unit price per each, which shall include all costs for work to install the barrier or watertight seal as specified herein, including all casting modifications, mortar leveling, and concrete removal and replacement.

## F. CASTINGS TO GRADE

This bid item shall include all work to adjust the casting with up to 4 rings, including all sealant, wrap, or chimney seals as specified herein. Adjustments to manholes located in the pave without concrete squares and adjustments to curb inlets shall be paid for under the "Casting to Grade – no Conc" bid item. Adjustments to manholes located in the pave with concrete squares will be paid for under the "Casting to Grade – w/Conc" bid item. Adjustments to inlets and manholes located outside the pave shall be paid for under the "Casting to Grade – Blvd" bid item.

On projects requiring concrete squares, the Contractor will be charged a penalty on a graduated scale for each casting that is not centered in the 5.0' x 5.0' concrete square as follows:

<b>Center of Casting to Center of Concrete Square</b>	<b>Penalty</b> (In the form of a negative extra item.)
0.0 feet to 0.25 feet	None.
0.26 feet to 0.50 feet	Deduct the greater of 15% or \$90.
0.51 feet to 0.75 feet	Deduct the greater of 30% or \$180.
Over 0.75 feet	Contractor shall remove, resize, and replace the concrete square at no additional cost to the City.

G. CASTING TO GRADE (OVER-DEPTH)

This bid item shall be paid for at the contract unit price per each, and shall include all costs for additional work required to adjust castings where more than 4 rings are required. Payment will be made for each increment of up to 4 rings beyond the initial 4 ring adjustment paid for under the Casting to Grade item.

H. VALVE BOXES TO GRADE

Adjustments to valve boxes located in the pave without concrete squares shall be paid for under the "GV Box to Grade – no Conc" bid item. Adjustments to valve boxes located in the pave with concrete squares will be paid for under the "GV Box to Grade – w/Conc" bid item. Adjustments to valve boxes located outside the pave shall be paid for under the "GV Box to Grade – Blvd" bid item.

On projects requiring concrete squares, the Contractor will be charged a penalty on a graduated scale for each gate valve box that is not centered in the 3.0' x 3.0' concrete square as follows:

<b>Center of Cover to Center of Concrete Square</b>	<b>Penalty</b> (In the form of a negative extra item.)
0.0 feet to 0.25 feet	None.
0.25 feet to 0.50 feet	Deduct the greater of 30% or \$150.
Over 0.50 feet	Contractor shall remove, resize, and replace the concrete square at no additional cost to the City.

I. TACK COAT

Tack coat shall not be a bid item – all costs for tack coat shall be included in the price bid for other items.

4.2.4. *OTHER COSTS*

All other costs for work necessary to properly complete the work specified herein shall not be bid items; the costs shall be charged to other items unless a bid item is specifically included on the bid sheet.

ZONING CLASSIFICATIONS	NOMINAL STREET WIDTH	ASPHALT PAVEMENT WIDTH	ASPHALT THICKNESS		AGGREGATE BASE THICKNESS	BASE COURSE CROSS SLOPE %
			AT CURB	AT CENTERLINE		
ALL SR AND MR LOCALS	24'	20'	7"	5.8"	7"	1.50%
	28'	24'	7"	5.6"	7"	1.50%
	30'	26'	7"	5.4"	7"	1.50%
	32'	28'	7"	5.3"	7"	1.50%
	36'	32'	7"	5.1"	7"	1.50%
	40'	36'	7"	5"	7"	1.57%
GO, TECH PARK LOCALS AND ALL COLLECTORS	28'	24'	9"	7.6"	8"	1.50%
	32'	28'	9"	7.3"	8"	1.50%
	40'	36'	9"	7"	8"	1.57%
	44'	40'	9"	7"	8"	1.67%
LC,GC,GI,LI LOCALS AND COLLECTORS	40'	36'	10"	8"	9"	1.57%

- NOTES:
- 1) SUBGRADE AND AGGREGATE BASE CROSS-SLOPE SHALL BE 2.50%.
  - 2) ND CLASS 31 WEAR COURSE REQUIRED FOR STREET WIDTHS IN EXCESS OF 40 FEET.
  - 3) SEE DETAIL 2400-5.2 FOR WEAR COURSE / EDGE MILL AND OVERLAY DETAIL.

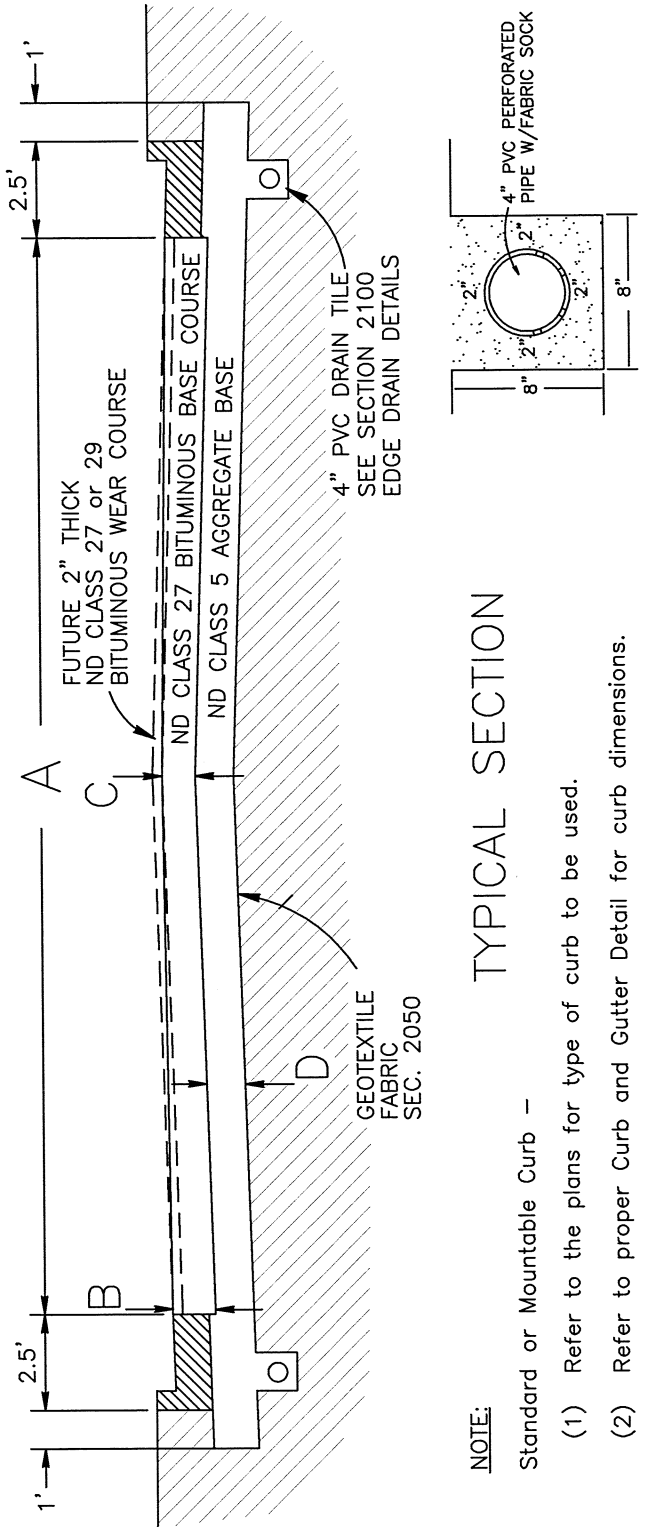

TYPICAL SECTION

Standard or Mountable Curb -

- (1) Refer to the plans for type of curb to be used.
- (2) Refer to proper Curb and Gutter Detail for curb dimensions.
- (3) Refer to the Typical Concrete Valley Gutter Detail to be used on Asphalt Paving projects only if indicated on plans.

SECTION NO.	2400	DRAWING NO.	5.1
REV.D.	2014		
<b>LOCAL / COLLECTOR TYPICAL SECTION</b>			
CITY OF FARGO ENGINEERING DEPARTMENT			
APPROVED	<i>ME</i>	DATE	12/10/13

- NOTES:
- 1) 10' WIDE EDGE MILL EACH SIDE.
  - 2) EDGE MILL SHALL BE 1.5" TO 2" DEEP AT CURB FLANGE.
  - 2) ND CLASS 31 WEAR COURSE REQUIRED FOR STREET WIDTHS IN EXCESS OF 40 FEET.

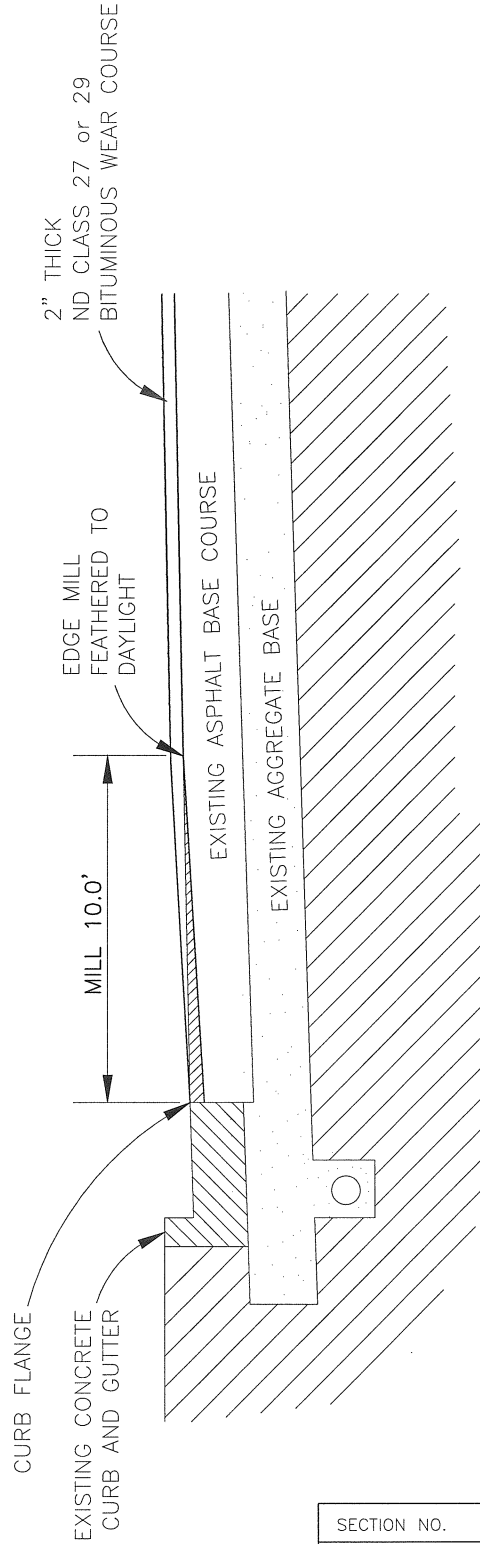

TYPICAL SECTION

SECTION NO. 2400	DRAWING NO. 5.2
REV.D. 2012	
<i>WEAR COURSE AND EDGE MILL &amp; OVERLAY</i>	
CITY OF FARGO ENGINEERING DEPARTMENT	
APPROVED <i>BED</i>	DATE <i>2-21-2012</i>

ASPHALT PAVEMENT WIDTH	LANES	ZONING CLASSIFICATIONS	PARKING	BACK-BACK MEASURE		AGGREGATE BASE WIDTH	ASPHALT THICKNESS		AGGREGATE BASE THICKNESS	CROSS SLOPE %	CROWN HEIGHT ABOVE OR BELOW TOP OF CURB	
				A	B		C	D			STD	MNTBLE
30'	2	ALL SR & MR-1	NONE	31	33	7"	2"	8"	2.50%	1 1/2"	BELOW	1 1/2" ABOVE
32'			ONE SIDE	33	35	7"	2"	8"	2.50%	1"	BELOW	1" ABOVE
40'			BOTH SIDES	41	43	7"	2"	8"	2.50%	EVEN		2" ABOVE
30'	2	MR-2 & MR-3	NONE	31	33	7"	2"	8"	2.50%	1 1/2"	BELOW	1 1/2" ABOVE
36'			ONE SIDE	37	39	7"	2"	8"	2.50%	1 1/2"	BELOW	1 1/2" ABOVE
44'			BOTH SIDES	45	47	7"	2"	8"	2.50%	1 1/2"	BELOW	1 1/2" ABOVE
32'	2	ALL OTHERS	NONE	33	35	7"	2"	8"	2.50%	1"	BELOW	1" ABOVE
36'			ONE SIDE	37	39	7"	2"	8"	2.50%	1 1/2"	BELOW	1 1/2" ABOVE
44'			BOTH SIDES	45	47	7"	2"	8"	2.50%	1 1/2"	BELOW	1 1/2" ABOVE
60'	2	ALL ZONES	BOTH SIDES	61	63	7"	2"	8"	2.50%	EVEN		2" ABOVE
36'	3	ALL SR & MR	NONE	37	39	7"	2"	8"	2.50%	1 1/2"	BELOW	1 1/2" ABOVE
40'	3	ALL OTHERS	NONE	41	43	8"	2"	9"	2.50%	EVEN		2" ABOVE

\*NOTE: ND CLASS 31 WEAR COURSE REQUIRED FOR STREET WIDTHS IN EXCESS OF 40 FEET.

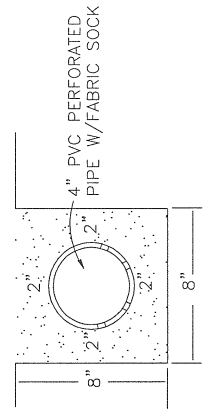
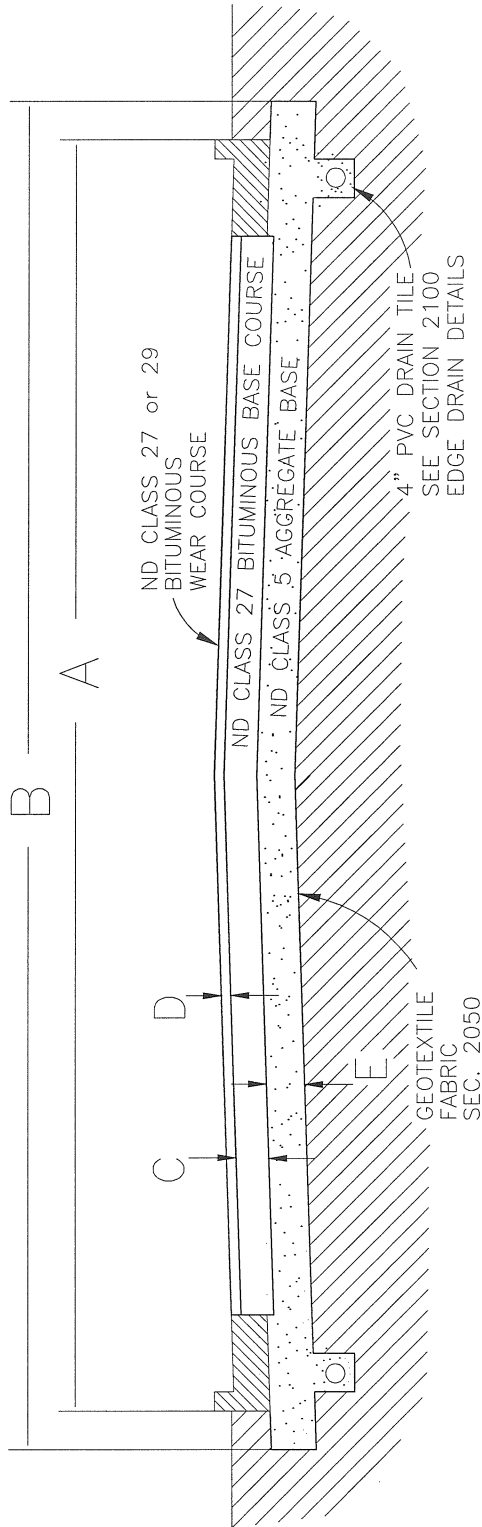

TYPICAL SECTION

TRENCH DETAIL

NOTE:

Standard or Mountable Curb -

- (1) Refer to plans for type of curb to be used.
- (2) Refer to proper Curb and Gutter Detail for curb dimensions.
- (3) Refer to the Typical Concrete Valley Gutter Detail to be used on Asphalt Paving projects only if indicated on plans.

SECTION NO. 2400	DRAWING NO. 5.3
REV.D. 2012	
<b>ASPHALT PAVEMENT PARKWAY STREET DETAILS</b>	
CITY OF FARGO ENGINEERING DEPARTMENT	
APPROVED <i>BEO</i>	DATE <i>2-21-2012</i>



TYPE	LANES	ZONING CLASSIFICATIONS	WIDTH		GRAVEL BASE THICKNESS	TOTAL ASPHALT THICKNESS	DITCH BOTTOM WIDTH	R/W (Feet)
			PAVED	GRADED				
LOCAL	2	ALL SR & MR	26'	34'	6"	5"	8'	90 MIN.
	2	ALL OTHERS	26'	34'	6"	8"	10'	90 MIN.
ARTERIAL	2	ALL ZONES	30'	40'	6"	8"	10'	100 MIN.

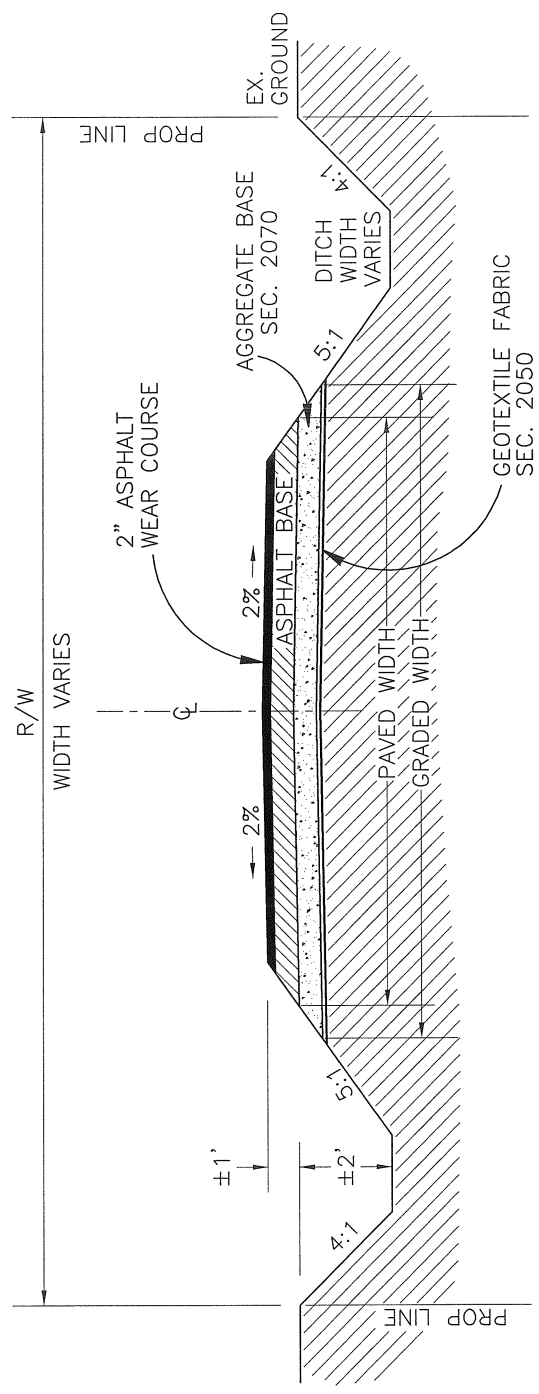

TYPICAL SECTION

SECTION NO. 2400	DRAWING NO. 5.4
REV.D. 2012	
<b>RURAL ASPHALT SECTION DETAIL</b>	
CITY OF FARGO ENGINEERING DEPARTMENT	
APPROVED <i>BED</i>	DATE <i>2-21-2012</i>

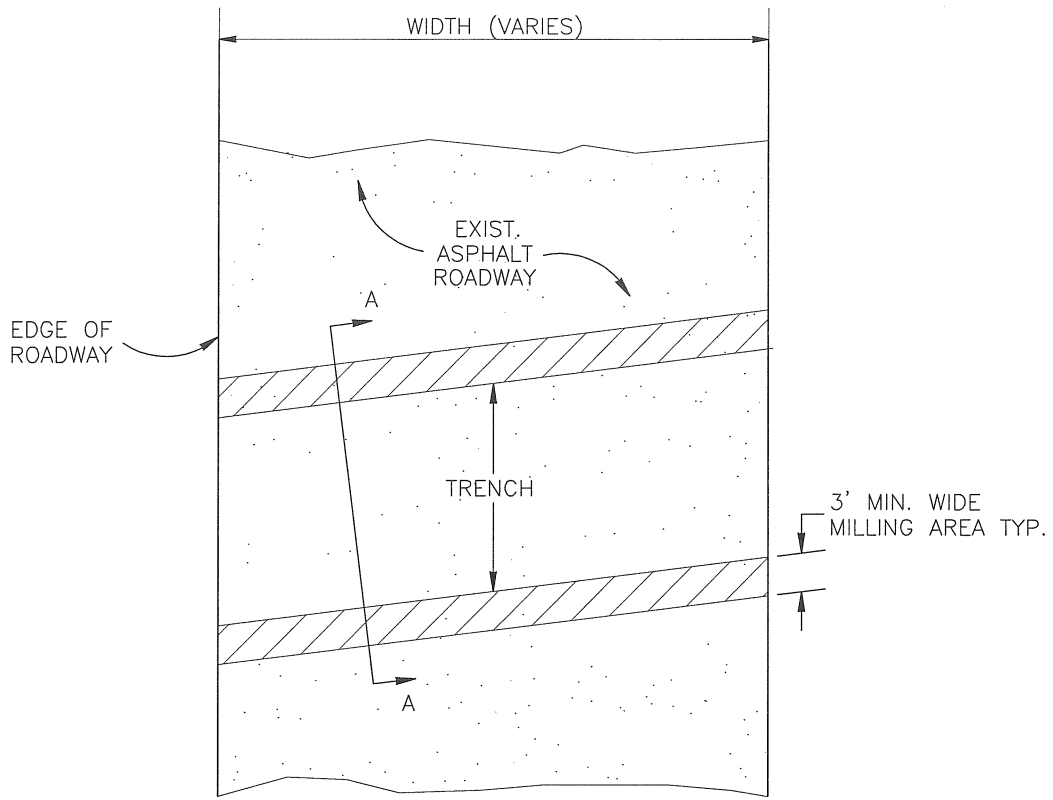

PLAN

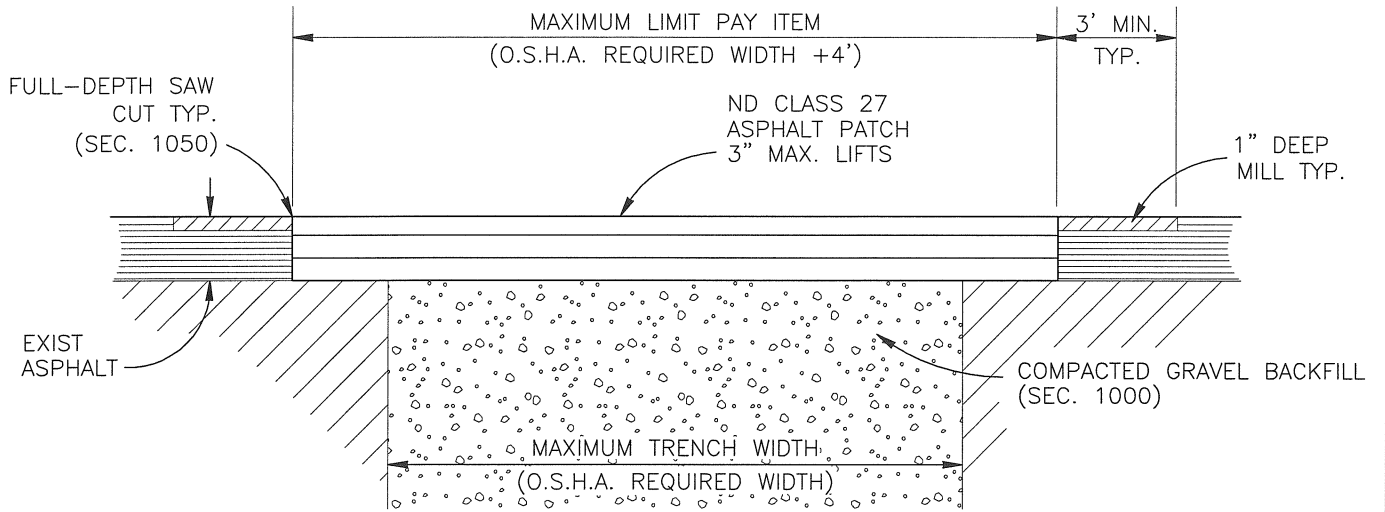

SECTION A-A

NOTES:

1. MATCH EXISTING ASPHALT THICKNESS UP TO 10" - INCLUDED IN SY PAY ITEM.
2. MILLING IS INCIDENTAL TO PATCHING.

SECTION NO.	2400	DRAWING NO.	5.5
REV.D.	2012		
<b>ASPHALT PAVEMENT PATCHING DETAIL</b>			
CITY OF FARGO ENGINEERING DEPARTMENT			
APPROVED	<i>BEO</i>	DATE	<i>2-21-2012</i>

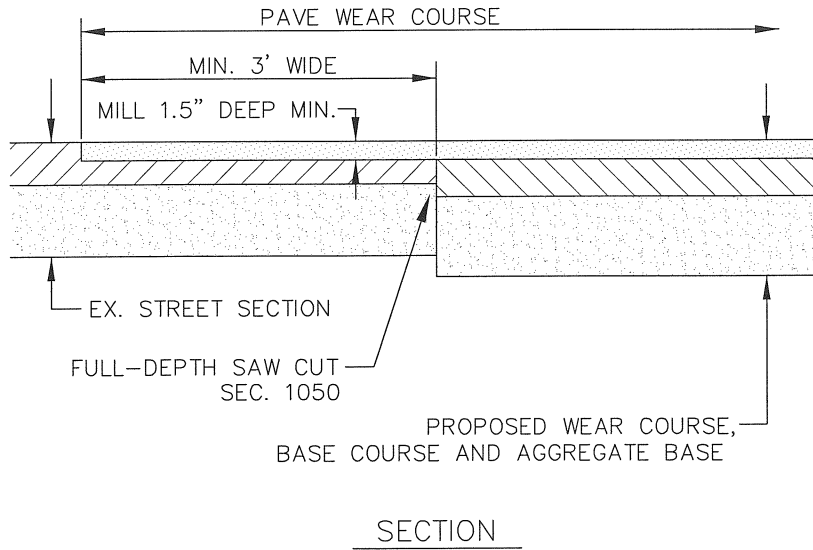
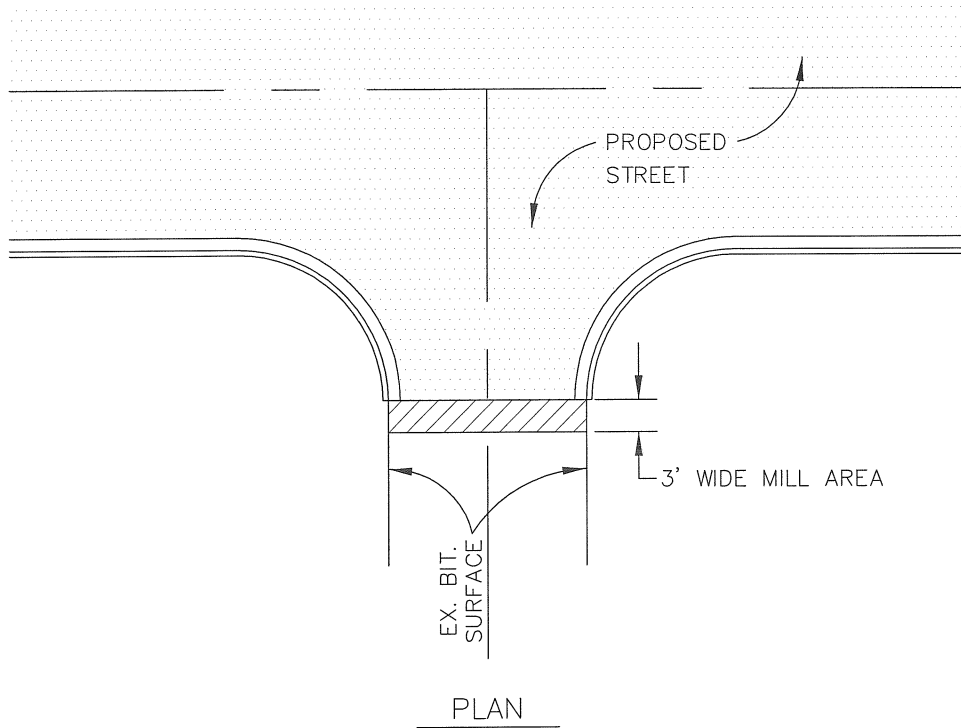

SECTION NO. 2400	DRAWING NO. 5.6
REV.D. 2012	
<i><b>MATCH EXISTING ASPHALT PAVEMENT</b></i>	
CITY OF FARGO ENGINEERING DEPARTMENT	
APPROVED <i>BED</i>	DATE <i>2-21-2012</i>

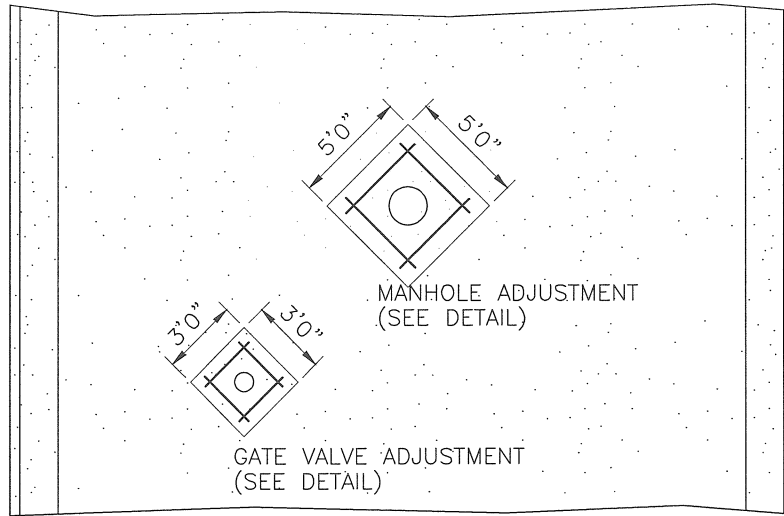

NOTES:

- 1) EXISTING WATERTIGHT MH SEAL SHALL BE SALVAGED AND REPLACED WHERE ENCOUNTERED.
- 2) WATERTIGHT MH SEAL OR CHIMNEY BARRIER SHALL BE INSTALLED WHERE NO EXISTING WATERTIGHT SEAL OR CHIMNEY BARRIER IS ENCOUNTERED.
- 2) THE MH FRAMES AND/OR GV BOXES NOT CENTERED IN THE CONCRETE SQUARE MAY BE SUBJECT TO PAY DEDUCTIONS. SEE SECTION 2400.4 OF THE STANDARD SPECIFICATIONS.
- 3) CONCRETE SHALL BE FLUSH WITH THE FINISHED PAVEMENT SURFACE.

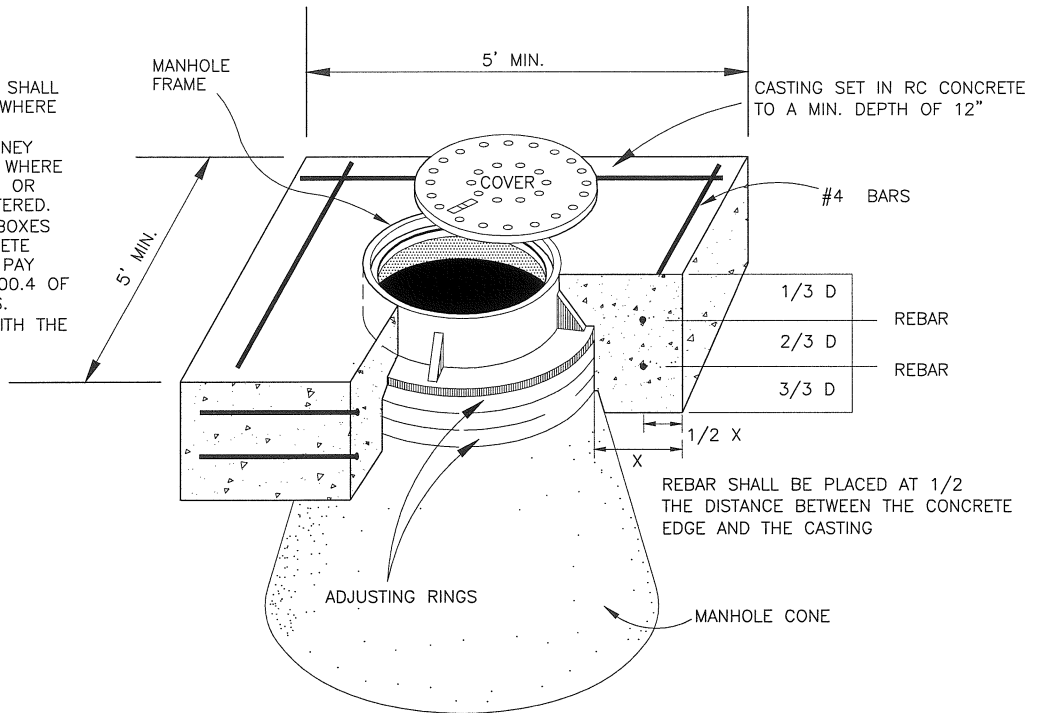

**MH CASTING TO GRADE  
(WITH CONCRETE)**

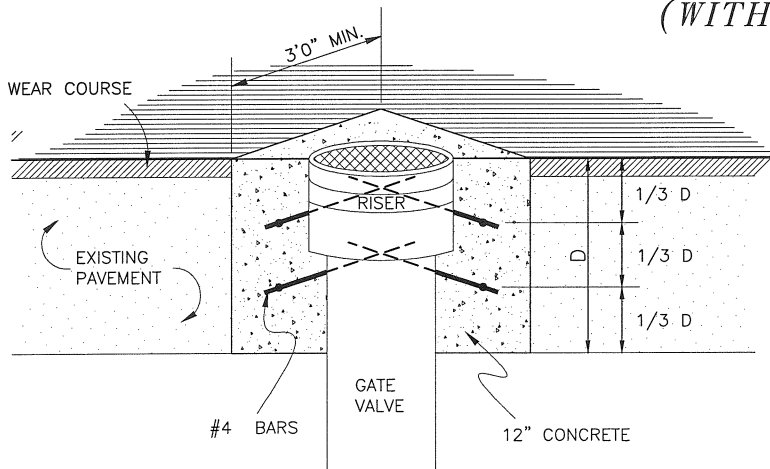

**GATE VALVE BOX TO GRADE  
(WITH CONCRETE)**

FOR ASPHALT OVERLAY  
AND FINAL WEAR COURSE PROJECTS

SECTION NO. 2400	DRAWING NO. 5.7
REV.D. 2012	

**CASTING & G.V. BOX  
TO GRADE DETAIL  
(WITH CONCRETE)**

CITY OF FARGO  
ENGINEERING DEPARTMENT

APPROVED <i>BEO</i>	DATE <i>2-21-2012</i>
---------------------	-----------------------

**CITY OF FARGO SPECIFICATIONS  
SEAL COATS**

**PART 1  
DESCRIPTION OF WORK**

The work to be done under this section of the Specifications and the accompanying plans consists of furnishing all labor, material, accessories, and plant necessary to complete the improvement of designated streets, avenues, or alleys in the City of Fargo.

This item shall include the cleaning, drying, and preparing the existing pavement and the application of the seal bitumen, seal aggregate, rolling, and other operations necessary to properly complete the seal coat.

All seal coat design and application shall be per the “Minnesota Seal Coat Handbook”, 2006 version.

**PART 2**  
**MATERIALS**

2.1. MATERIAL

All material shall be obtained from approved sources and shall conform to the latest applicable ASTM standards.

*2.1.1. SEAL BITUMEN*

Seal bitumen shall be polymer-modified cationic emulsified asphalt: CRS-2P, and shall be produced by using polymer-modified base asphalt only. The use of latex modification will not be allowed. The particular seal bitumen used for the seal coat shall be subject to the approval of the Engineer. The Contractor shall provide the Engineer with a sample from each tanker. Each sample shall be in a clean, sealed plastic container.

The emulsion shall be protected from freezing and from separating and breaking. Any emulsion that has been frozen or has separated and broken will be rejected and removed from the site at the Contractor's expense.

*2.1.2. SEAL AGGREGATE*

Seal aggregate shall be free of dirt, strippings, and organic matter, and shall be sufficiently moistened with water so that it is in the saturated surface dry condition when applied. The seal aggregate shall be a Minnesota Class A aggregate.

“Seal Aggregate A” shall conform to a MnDOT FA-2 gradation and quality.

“Seal Aggregate B” shall conform to a MnDOT FA-3 gradation and quality.

*2.1.3. ASPHALT WEARING COURSE*

Per Section 2400 of these Specifications.

#### *2.1.4. DESIGN AND SUBMITTALS*

The Contractor shall perform a design as outlined in the Minnesota Seal Coat Handbook and provide the following information to the Engineer for review and approval two weeks before construction is planned to begin:

- 1) Test results on aggregate gradation.
- 2) Seal aggregate design application rate for each aggregate size.
- 3) Seal oil design application rate.
- 4) Loose unit weight of each aggregate size.
- 5) Bulk specific gravity of each aggregate size.

Note: The seal aggregate design application rate is the minimum application rate based on the design program. Any additional material needed, as determined by the Engineer in the field, shall be considered incidental to the respective seal aggregate bid item.

#### *2.2. EQUIPMENT*

All equipment shall be kept in satisfactory repair at all times and shall meet the approval of the Engineer.

##### *2.2.1. BROOMS*

All brooms shall be motorized with a positive means of controlling vertical pressure and capable of cleaning the streets prior to spraying bituminous material and also removing loose aggregate after seal coating. Each broom shall be constructed so that the revolutions may be adjusted to its progression.

##### *2.2.2. ASPHALT DISTRIBUTOR*

The distributor shall be capable of uniformly distributing the bituminous material at the desired rate. It shall be equipped with a pressure pump and gauges capable of maintaining uniform and adequate pressure throughout the length of the spray-bar. The distributor shall have a system to evenly heat and circulate the material and be equipped with a thermometer to accurately measure the temperature. It shall be equipped with adjustable full circulation spray-bars with cut off valves or other means of starting and

stopping the flow of bitumen quickly and uniformly over the length of the spray-bar. The Contractor shall make available data showing the manufacturer's recommendation for spray bar height above the surface, nozzle size, and the angle of the spray fan with the spray bar axis. Nozzles shall be clean and at the correct angle.

The truck shall be equipped with a tachometer, operated by a wheel independent of the truck wheels, to accurately measure the truck speed in feet per minute. A bitumeter and tachometer chart shall be kept in the truck at all times. These charts shall be readily available to the Engineer at any time during the job to check the application rates of the bituminous material. The distributor shall be equipped with a digital application rate indicator that indicates the application rate in square yards as the truck is applying the bitumen.

### 2.2.3. SCALES

The scales shall be of the platform type sensitive to a weight of twenty pounds and shall have the capacity to weigh the maximum load. The scales shall be approved and calibrated by the state in which it is located and proof of such calibration furnished to the Engineer upon his request.

### 2.2.4. PNEUMATIC TIRED ROLLERS

Rollers shall be equipped with a minimum of six wheels in front and seven wheels in the rear. Each wheel shall be mounted on an oscillating axle and the rear wheels shall be staggered with the front wheels. They shall be constructed so that they can be loaded to a gross weight of at least two hundred and twenty-five (225) pounds per inch of tread width.



### 2.2.5. *AGGREGATE SPREADER*

The mechanical spreader shall be capable of placing the designated amount of aggregate in a smooth, uniform layer on the seal bitumen. The spreader shall be designed so the wheels do not contact the seal bitumen before it is covered with the aggregate. The application rate of the spreader shall be adequate to cover the width of one traffic lane plus one foot minimum. The spinner broadcast type of aggregate spreader will not be allowed. Prior to the application of the aggregate, the Contractor shall verify with the Engineer that the machine has been calibrated to evenly distribute the designated amount of aggregate.

Calibration and testing shall be done in accordance with the latest revision of ASTM D-5624. The spreader shall be adjusted to provide uniform coverage across the entire width of the spreader, plus or minus one pound per square yard. If the spreader is not calibrated, the project will be suspended until calibration has been completed.

**PART 3**  
**CONSTRUCTION**

3.1. PREPARATION OF THE EXISTING PAVEMENT

All loose, pocketed, caked, or other deleterious material shall be removed from the existing pavement. Flushing or sweeping with hand or power brooms will be acceptable methods of cleaning the pavement and shall be done daily prior to the application of the seal bitumen.

When directed by the Engineer, asphalt wearing course shall be used to level depressed joints and depressions. The leveling process shall be done a minimum of 2 weeks prior to the chip seal installation. Wear course leveling shall be according to Section 2400 of these Specifications.

All costs associated with installing the leveling course shall be included in the bid item for "Asphalt Wearing Course".

3.2. TEST STRIPS

The Contractor shall spray and apply chips to a test strip of approximately 50 feet to be certain the chips are being properly embedded in the oil. This process will be repeated as necessary until the proper application rate is verified.

Note: Application rates may vary according to specific design for the particular aggregate used.

The Contractor shall submit an aggregate sample to a local testing company to determine the appropriate aggregate and oil application rate for bidding purposes.

The Contractor shall make certain the distributor and aggregate spreader are in good working order and calibrated to apply the materials at the specified rates. If the Contractor fails to calibrate the equipment prior to the start of the project, the project will be shut down until the Contractor can verify that the equipment is properly calibrated and prove to the Engineer that the design application rates are being obtained.

### 3.3. APPLICATION OF THE SEAL BITUMEN

Prior to applying the seal bitumen, all manhole castings and gate valves, including any concrete surrounding them, shall be covered with paper, sand, or other effective means to prevent the seal bitumen from coming into contact with them. The application of the seal bitumen shall not begin until the aggregate and aggregate spreader and rollers are standing by and ready to follow immediately.

The application rate of the bitumen shall be based on the design, adjusted by the Engineer for varying pavement surface conditions. The application rate may be varied by the Engineer at any time during the work to adjust to conditions. The spraying temperature shall be within the following limits at the time of application: Temperature = 110 to 160° F (40 to 70° C).

The seal bitumen shall only be applied when the pavement and air temperature is at least 60° F (15.5°C) and rising.

The Contractor shall use appropriate procedures to make certain oil spray does not overlap at longitudinal or transverse edges when continuing on from a previous application.

### 3.4. APPLICATION OF THE SEAL AGGREGATE

The application of the seal aggregate shall begin immediately behind the asphalt distributor. **Seal bitumen shall be covered with the aggregate in less than one minute and the aggregate shall be initial-rolled within 2 minutes of being spread.** The aggregate shall be applied with the spreader and shall be in the saturated surface dry condition at the time of application.

Any areas in which aggregate is not placed within 90 seconds of the oil being shot will be rejected and no payment will be made for the rejected area.

The application rate of the aggregate shall be based on the design, adjusted by the Engineer for varying pavement surface conditions. The application rate may be varied by the Engineer at any time during the work to adjust to conditions.

Areas inaccessible to mechanical equipment shall be sealed by hand equipment in an approved manner. The Contractor shall remove any excessive deposits of aggregate that may result in a rough ride.

### 3.5. ROLLING THE SEAL COAT

Rolling shall be commenced as soon as the aggregate has been spread, with initial rolling completed within 2 minutes of being spread. A minimum of three pneumatic tired rollers shall be used to embed the aggregate. Rolling shall be done in straight, parallel, overlapping strips as quickly as possible before the asphalt emulsion breaks. Travel speed of the roller should not exceed 5 mph so that the chips are properly embedded. As soon as rolling has been completed the street may be opened to traffic.

### 3.6. PAVEMENT MARKINGS AND TEMPORARY TABS

Refer to Section 4000 of these Specifications for pavement marking and temporary tab requirements for seal coat projects.

### 3.7. TRAFFIC CONTROL

The Contractor shall conduct his work in such a manner as to interfere as little as possible with the use of the streets for public travel. When streets or public thoroughfares are impacted by construction activity, the public shall be protected by placement of adequate warning devices. All barricades and obstructions shall be illuminated by means of amber lights or reflective sheeting for nighttime hours. All traffic control devices shall be constructed, maintained, and located in accordance with the current version of the "Manual of Uniform Traffic Control Devices" as set forth by the U. S. Department of Transportation and the Federal Highway Administration. "Fresh Oil, Loose Rock" signs shall be placed at all ends of the project and temporary "No Parking" signs shall be furnished, installed, and removed by the Contractor at no additional cost to the City.

### 3.8. SWEEPING OF THE EXCESS AGGREGATE

The Contractor shall sweep the streets within 48 hours of placing the seal aggregate on the street. All costs for sweeping shall be included in the price bid for seal aggregate. The Contractor shall promptly repair any defects uncovered during the sweeping process. All sweepings shall become the property of the Contractor to be disposed of at his discretion. Should the Contractor request it, the City will provide a dump site located within the Fargo city limits for disposal of the sweepings.

**PART 4**  
**GUARANTEE, MEASUREMENT & PAYMENT**

4.1. GUARANTEE

The guarantee shall be per the contract.

4.2. MEASUREMENT AND PAYMENT

*4.2.1. SEAL BITUMEN (SEAL OIL)*

Payment for seal oil shall be by the gallon, calculated using the square yardage times the application rate, or the sum of the gallons shown on the tanker manifests, whichever is less.

*4.2.2. SEAL AGGREGATE*

Payment for seal aggregate shall be by the square yard, calculated by the Engineer using digital area calculation methods available in CAD software.

*4.2.3. ASPHALT WEARING COURSE*

Payment for asphalt wearing course shall be by the ton including 5 ½ to 6% asphalt cement.

*4.2.4. TRAFFIC CONTROL*

Traffic control shall be paid on a lump-sum basis per section of the project, and shall include all costs to control parking and protect the travelling public as outlined in this specification.

*4.2.5. OTHER COSTS*

All other costs for work necessary to properly complete the work specified herein shall not be bid items; the costs shall be charged to other items unless a bid item is specifically included on the bid sheet.

**CITY OF FARGO SPECIFICATIONS  
GRADING ROADS**

**PART 1  
DESCRIPTION OF WORK**

The work to be done under this section of the Specifications and the accompanying plans consists of all labor, material, accessories, and equipment necessary to prepare a roadbed, complete the subgrade preparation, and such other work and incidentals as may be necessary to properly complete the work. Generally this item will be used to provide access to properties in the interim period between underground installation and the paving of the project area.

**PART 2**  
**MATERIALS**

2.1. TRAFFIC SURFACE GRAVEL

Traffic surface gravel shall meet the requirements of Section #2800 of these Specifications.



**PART 3**  
**CONSTRUCTION**

3.1. CLEAN-UP AND LEVEL OF AREA

The Contractor shall clean up and level the street right-of-way on all streets where the underground utilities were installed.

3.2. CONSTRUCTION SEQUENCE

- A. The Engineer will provide a lathe line to define the ditch alignment and indicate the location of the high and low points, however no invert elevations will be provided for the ditches being staked. The Contractor shall then cut in “V” ditches to provide drainage to the new storm inlets.
- B. Excess material from the ditches will be used to elevate a 24-foot wide roadbed between the ditches. The roadbed shall be compacted using a sheepsfoot roller or other suitable compaction equipment. While no compaction density is specified, the roadbed shall have stability such that no rutting or displacement of the roadbed shall occur as the gravel is being placed.
- C. The roadbed shall be uniformly graded and the traffic surface gravel shall be furnished and spread by the Contractor.
- D. The typical section shall have a 24-foot wide top with 6 inches of crown centered on the roadbed. The “V” ditches shall have 3:1 sideslopes and shall vary in depth to match the existing ground and new inlets.

**PART 4**  
**GUARANTEE, MEASUREMENT & PAYMENT**

4.1. GUARANTEE

The guarantee does not apply for this section of the Specifications.

4.2. MEASUREMENT AND PAYMENT

*4.2.1. GRADE ROADWAY*

The bid item will be measured and paid for based on the linear foot of roadbed constructed. Measurement will be taken along the centerline of all roadbeds constructed. A deduction will be made for the roadbed width in one direction across intersections. The subgrade preparation and compaction are incidental to this item.

*4.2.2. OTHER COSTS*

All other costs for work necessary to properly complete the work specified herein shall not be bid items; the costs shall be charged to other items unless a bid item is specifically included on the bid sheet.

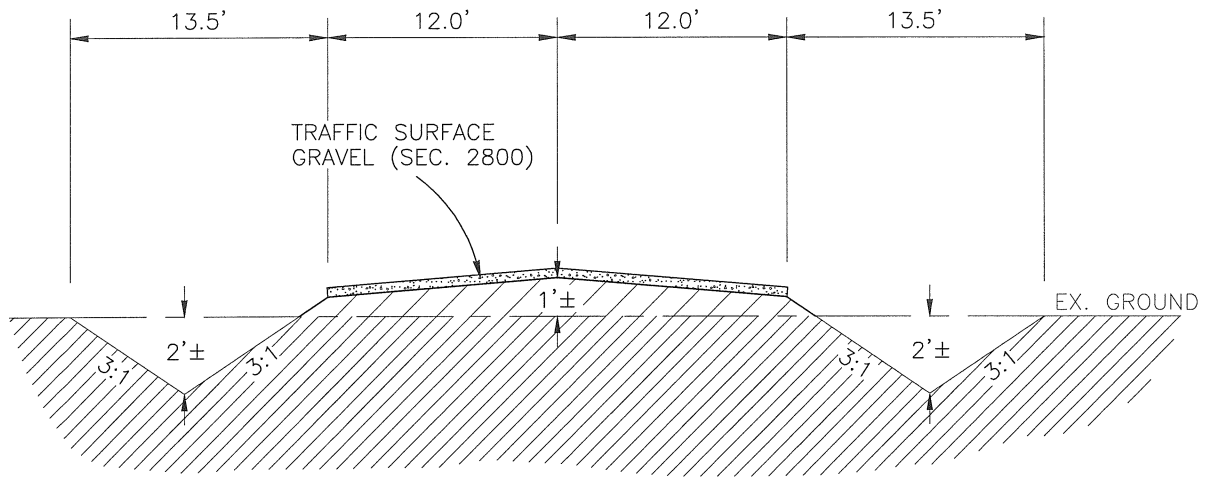

SECTION NO. 2700	DRAWING NO. 5.1
REV.D. 2012	
<b>GRADING ROAD TYPICAL SECTION</b>	
CITY OF FARGO ENGINEERING DEPARTMENT	
APPROVED <i>BED</i>	DATE <i>2-21-2012</i>

**CITY OF FARGO SPECIFICATIONS  
GRAVEL SURFACING**

**PART 1  
DESCRIPTION OF WORK**

The work to be done under this section of the Specifications shall include all labor, materials, scales, accessories, and other work necessary to furnish and spread traffic surface gravel at the locations designated by the Engineer.

**PART 2**  
**MATERIAL**

2.1. MATERIAL

Traffic surface gravel shall conform to the requirements of ND Class 13 Aggregate.

2.2. EQUIPMENT

Scales shall be of the platform type sensitive to a weight of twenty pounds and shall have the capacity to weigh the maximum load. Any scale shall be approved and calibrated by the state in which it is located and proof of such calibration shall be furnished to the Engineer upon request. Each truck shall have a ticket showing its weight and the weight of the gravel being hauled in decimal fractions of tons.

**PART 3**  
**CONSTRUCTION**

3.1. SPOT LOCATION GRAVEL SURFACING

The Contractor shall haul, deliver and spread the gravel at the location designated by the Engineer. The aggregate shall be deposited, spread, and shaped to conform to the required grade.

3.2. GRAVEL SURFACING ON GRAVEL SURFACING PROJECTS

The Contractor shall haul, deliver and spread-dump the gravel to the approximate depth required. The Engineer will furnish person to direct the trucks where to dump and to collect load tickets. The Contractor shall furnish a maintainer blade and operator on these projects to grade and compact the gravel to the desired depth and density. Water shall be applied to moisten the material prior to/during compaction. The aggregate shall be deposited, spread and shaped so the moist compacted gravel will be tightly bound, smooth and uniform.

**PART 4**  
**GUARANTEE, MEASUREMENT & PAYMENT**

4.1. GUARANTEE

The guarantee does not apply to this section of the Specifications.

4.2. MEASUREMENT AND PAYMENT

*4.2.1. TRAFFIC SURFACE GRAVEL*

Traffic Surface Gravel shall be paid for at the contract unit price per ton. The Contractor shall provide the Engineer in the field at the point of delivery with computer-generated haul tickets for each load showing the scaled weight of the material incorporated into the project. If tickets are not delivered in this manner, the material will not be eligible for payment unless the Engineer has given prior written approval for some other ticket delivery method.

*4.2.2. OTHER COSTS*

All other costs for work necessary to properly complete the work specified herein shall not be bid items; the costs shall be charged to other items unless a bid item is specifically included on the bid sheet.

**CITY OF FARGO SPECIFICATIONS**  
**PAVEMENT MILLING OR GRINDING**

**PART 1**  
**DESCRIPTION OF WORK**

The work to be done under this section of the Specifications and the accompanying plans shall consist of furnishing all labor, material, accessories, and plant necessary to complete the improvement of certain streets, avenues or alleys in the City of Fargo.

This work shall include the milling of asphalt pavements and/or diamond grinding of concrete pavements to produce a uniform section and smooth riding surface, and shall include the removal and disposal of all milling/grinding residue and the sweeping and cleaning of the existing and milled surfaces, and all other work as may be necessary to properly complete the pavement profiling work in accordance with these Specifications and the accompanying plans.



**PART 2**  
**MATERIALS**

2.1. EQUIPMENT

All equipment shall be maintained in good repair and shall meet the approval of the Engineer. Water for the milling and cleaning operation is available from the city hydrants, however the use of such hydrants shall comply with the City of Fargo Water Department regulations.

*2.1.1. MILLING MACHINE*

The milling machine shall be a self-propelled machine specifically designed to fully or partially remove existing pavement to the desired depth, profile, cross slope and surface texture. The machine shall have a control system to automatically control the elevation and transverse slope of the milling head. The machine shall be equipped with a conveyor capable of loading the milled material directly from the roadway to a truck. The machine shall be equipped with a minimum 15-foot long skid or rolling straightedge and grade control sensors to automatically maintain proper grade and alignment.

*2.1.2. BROOMS*

The Contractor will be required to have a mechanical broom of the revolving type and be so constructed that the revolutions may be adjusted to its progression. Brooms used for finish sweeping shall be of the “pick-up” or vacuum type wherein material from the road surface is removed by the machine for subsequent disposal at a different location.

*2.1.3. DIAMOND GRINDING MACHINE*

Grinding and texturing shall be completed utilizing diamond blades, mounted on a self-propelled machine, designed for grinding and texturing of pavements. The equipment shall not cause strain or damage to the underlying surface of the pavement. Grinding and texturing equipment that causes excessive ravels, aggregate fractures, spalling, or disturbance of the joints shall not be permitted.

**PART 3  
CONSTRUCTION**

3.1. SURFACE PREPARATION

The existing pavement surface shall be cleaned of deleterious material prior to any milling or grinding operation.

3.2. MILLING FULL WIDTH

The milled surface shall be free from transverse and longitudinal irregularities in excess of 1/4 inch when measured with a 10-foot straightedge. Special care shall be taken along the face of the curb section to remove all asphalt, seal material, or other debris from the exposed face of the curb and gutter section. Milling shall proceed from curb to curb at a width and depth designated by the Engineer.

3.3. EDGE MILLING

The pavement edge shall be milled from the face of the gutter section to approximately 10 feet out from the edge of the gutter section; that point being at a distance where the milling shall “daylight” out or that the transition in depth shall be non-discernible. Special care shall be taken along the face of the gutter section to remove all asphalt, seal material, or other debris from the exposed face of the curb and gutter section. Milling depth along the curb shall generally be from 1” to 1 1/2” in depth or as designated by the Engineer.

3.4. DISPOSAL OF MILLED ASPHALT MATERIAL

Unless otherwise designated in the special instructions, all milled asphalt material shall be hauled to the City of Fargo Landfill at 7th Ave N. and 45th St. The Contractor shall coordinate all hauling times with the landfill personnel. The milled material shall be dumped at the location designated by the landfill personnel who will then move and stockpile the material.

3.5. CLEANING OF THE MILLED SURFACE

The milled pavement surface shall be cleaned by sweeping during and immediately after the milling operation. The Contractor shall make every effort to keep the dust to a minimum and to ensure that the milled debris is not spread onto the adjacent boulevards and sidewalks. Any debris inadvertently spilled on sidewalks or boulevards shall be promptly removed to the satisfaction of the Engineer.

3.6. DIAMOND GRINDING

Grinding shall be performed in the longitudinal direction so grinding begins and ends at lines normal to the pavement centerline. The allowable overlap between passes shall be 0 to 2 inches

and the maximum allowable depth variance between adjacent passes shall be 1/8 inch. The grinding shall be feathered out as directed by the Engineer.

The surface of the ground pavement shall have a texture consisting of grooves between .090 and .130 inches wide. The peaks of the ridges shall be approximately 1/32 inch higher than the bottom of the grooves.

High shoulders shall be ground to provide drainage and safety.

Where present in a given area of grinding, pavement marking tape shall be obliterated by the Contractor prior to grinding operations, with the exception of centerline skips, which shall be ground with the pavement surface. Obliteration shall be in accordance with section 4000 of these Specifications.

The pavement shall be left in a clean condition. The removal of all slurry or residue resulting from the grinding operation shall be continuous. The grinding operation should be controlled so the residue from the operation does not flow across lanes utilized by traffic.

### 3.7. DISPOSAL OF CONCRETE SLURRY MATERIAL

The Contractor shall dispose of or recycle all slurry and other residue created by the grinding of concrete pavements. The disposal site shall be selected by the Contractor, and shall be appropriate for the disposal of concrete slurry, such as a settling pit or other appropriate facility.

### 3.8. TRAFFIC CONTROL

The Contractor shall conduct his work in such a manner as to interfere as little as possible with the use of the streets for public travel. When streets or public thoroughfares are impacted by construction activity, the public shall be protected by placement of adequate warning devices. All barricades and obstructions shall be illuminated by means of amber lights or reflective sheeting for nighttime hours. All traffic control devices shall be constructed, maintained, and located in accordance with the current version of the "Manual of Uniform Traffic Control Devices" as set forth by the U. S. Department of Transportation and the Federal Highway Administration. Where necessary, temporary "No Parking" signs shall be furnished, installed, and removed by the Contractor at no additional cost to the City.

3.9. CASTINGS AND GATE VALVES TO GRADE

All casting and/or valve box adjustments required on the project shall be in accordance with Section 2400 of these Specifications.

**PART 4**  
**GUARANTEE, MEASUREMENT & PAYMENT**

4.1. GUARANTEE

The guarantee is not applicable to this section.

4.2. MEASUREMENT AND PAYMENT

*4.2.1. MILLING PAVEMENT SURFACE*

Milling pavement surface shall be measured by the square yard of actual milled surface. Payment will be based on the unit bid price per square yard at the applicable depth ranges.

*4.2.2. EDGE MILLING*

Edge milling will be measured and paid for based on the linear feet of edge milling completed. Payment will be based on the unit bid price per linear foot.

*4.2.3. DIAMOND GRINDING*

Diamond-grinding concrete pavement surfaces shall be measured by the square yard of actual ground surface. Payment will be based on the contract unit price per square yard for Surface Grinding.

*4.2.4. TRAFFIC CONTROL*

Traffic control shall be paid on a lump-sum basis per section of the project or as provided for on the bid sheet, and shall include all costs to control parking and protect the travelling public as outlined in this specification.

*4.2.5. OTHER COSTS*

All costs for cleaning/sweeping the existing surface, transporting and disposal of the milled material or slurry, and all other costs necessary to complete the work as specified herein shall not be bid items; the costs shall be charged to other items unless a bid item is specifically included on the bid sheet.

**CITY OF FARGO SPECIFICATIONS  
TURF ESTABLISHMENT**

**PART 1  
DESCRIPTION OF WORK**

This work to be done under this section of the Specifications and the accompanying plans consists of establishing turf on boulevards, slopes, ditches, or other locations shown on the plans or as designated by the Engineer.

**PART 2**  
**MATERIAL**

2.1. TOPSOIL

All topsoil shall meet the requirements specified in Section 2000 of these Specifications.

2.2. SEED

All seed shall be labeled in accordance with U. S. Department of Agriculture rules and regulations under the Federal Seed Act in effect on the date of the invitation to bids. Seed shall be furnished separately or in mixture in standard sealed containers. Damaged, wet, or moldy seed will not be accepted. All seed shall meet the minimum requirements for purity and germination. No purity or germination tolerance will be allowed. Weed seed shall not exceed 0.5% of the total mixture, and seed shall contain no noxious weed seed of the state from which seed is to be shipped.

Seed tags shall be provided with each bag of seed used on the project and shall be given to the Engineer. Seed certifications from seed supplier shall be provided upon request. Labels for seed shall contain the following:

1. Name and address of supplier
2. Lot number
3. Seed name and origin for each kind of seed
4. Percentages of purity and of germination for each kind of seed & percentage of weed seed content in the mixture.
5. Date of last test
6. Pounds of bulk seed for total mix in each bag

Seed mixtures shall conform to the following types:

A. Type A - Ditches and Side Slopes:

<u>Kind Of Seed</u>	<u>Percentage</u>		
	<u>by Weight</u>	<u>Purity</u>	<u>Germination</u>
Meadow Brome Grass	30%	85%	85%
Intermediate Wheatgrass	30%	90%	85%
Crested Wheatgrass	30%	90%	85%
Tetraploid Int. Perennial Ryegrass	10%	95%	85%

Rate of Seeding = 75 Pounds per Acre

Seed mixture shall contain one of the following companion crops at the specified application rate:

1. April 1 to June 15 seeding – 15 pounds/acre of Oats.
2. June 15 to August 15 seeding – 8 pounds/acre of Millet.
3. August 15 to December 1 seeding – 15 pounds/acre of Rye or Winter Wheat.

B. Type B - Parks, Boulevards, Private Property, Built-Up Areas:

<u>Kind Of Seed</u>	<u>Percentage</u>		
	<u>by Weight</u>	<u>Purity</u>	<u>Germination</u>
Kentucky Bluegrass	60%	90%	85%
Creeping Red Fescue	10%	90%	85%
Fine Leaf Perennial Ryegrass	30%	95%	90%

Percent by weight shall be plus or minus 5 % on all seed types.

Rate of Seeding = 220 Pounds Per Acre (5 Pounds Per 1,000 Sq. Ft.)

C. Type C - Other Applications:

See the Special Instructions for the seed mix design and application rate.

2.3. FERTILIZER

Fertilizer shall be a standard commercial grade product, free flowing and suitable for application with mechanical equipment, delivered in clean, sealed, moisture-proof & properly labeled containers bearing the name, trade name or trade mark and warranty of the producer. Fertilizers shall be recommended for grass, supplied separately or in mixtures. Fertilizer shall conform to all State and Federal regulations. All fertilizer shall contain slow release nitrogen in the form of inorganic chemicals amounting to at least 50% of the available nitrogen specified.

A. Type A & Type B Seeding:

Starter Fertilizer: Fertilizer shall be 12-24-12 at an application rate of 220 pounds per acre (5 pounds per 1,000 sq. Ft.).



Turf Fertilizer: Fertilizer shall be 24-24-4 at an application rate of 110 pounds per acre (2.5 pounds per 1,000 sq. Ft.).

B. Type C Seeding:

Fertilizer design and application rates will be as specified in the Special Instructions.

2.4. MULCH

A. *MULCHING – TYPE 1 (HYDRO MULCH)*

Hydro mulch shall be virgin wood fiber mulch for use in hydraulic planting, cooked cellulose fiber which shall have the property of dispersing readily in water and shall have no toxic effect when combined with seed or other materials. The mulch shall be treated with a tackifier to enhance mulch placement and adherence to the soil. A green colored dye which is non toxic to plant growth shall be used. Wood cellulose fiber shall be packaged in new, labeled containers, shall have an equilibrium air-dried moisture content of 12% plus or minus 3% at time of manufacture, and shall have a pH range of 3.5 to 5.0. No sawdust or byproduct mulch will be allowed. The homogenous slurry or mixture shall be capable of application with power spray equipment. Hydromulch shall be applied at a rate of 2,000 pounds per acre (45 pounds per 1,000 sq. Ft.).

B. *MULCHING – TYPE 2 (STRAW MULCH)*

Material for straw mulching shall be threshed stalks of native oats, wheat, barley or rye, and shall be weed free to prevent the introduction of noxious weeds as defined by the North Dakota Department of Agriculture. At least 50% of the mulch by weight shall be 10 inches or more in length. Musty, moldy, caked or otherwise low quality straw is not acceptable. Dry mulching material that breaks and does not bend is not acceptable. Hay or chopped cornstalks are not acceptable. Application rate is 2 tons per acre (90 pounds per 1,000 sq. Ft.).

2.5. WEED CONTROL

- A. Type A – Non-Selective Herbicide: Round-up, glyphosate or approved equal,
- B. Type B – Selective Herbicide: Trimec, 2,4-D or approved equal.

**PART 3**  
**CONSTRUCTION**

3.1. PREPARATION OF AREAS TO BE SEEDED

Prior to or during grading and tillage operations, the ground surface shall be raked and cleared of all stumps, brush, sticks, roots, stones larger than 1/2 inch in diameter, concrete chunks, rebar, wire or other material that may hinder seeding and maintenance operations. Any accumulated material shall be disposed of by the Contractor at no additional cost to the City.

If any damage by erosion or other causes has occurred after the completion of grading and before beginning the application of fertilizer, the Contractor shall repair such damage. This may include filling gullies, smoothing irregularities, and repairing other incidental damage.

Areas that may be weedy, un-worked, or packed hard, shall first have any grass and weeds cut & disposed. The seed bed shall be disked or cultivated to a minimum depth of 3". A harrow or cultipack shall be used so that the bed is firm and the seed can be placed at the proper depth. The seed bed shall be smooth and firm, and all lumps or clods exposed shall be broken up to an inch in diameter or less.

3.2. TOPSOIL PLACEMENT

Topsoil placement shall be in accordance with Section 2000 of these Specifications.

3.3 FERTILIZING

Starter Fertilizer: Either immediately prior to or after seeding, Starter Fertilizer conforming to the above requirements shall be applied at the rate specified above and raked into the soil.

Turf Fertilizer: When the grass has been evenly established to a height of 2", or eight weeks after the Starter Fertilizer application, whichever occurs sooner, Turf Fertilizer conforming to the above requirements shall be applied at the rate specified above. Contractor shall water the turf immediately after application of Turf Fertilizer.

### 3.4. PLANTING SEED

Prior to planting of the seed, fertilizer shall be applied at the specified rate & shall be incorporated into the soil to a minimum depth of two inches. All seeding shall be done when the ground is open, not frozen or covered with snow, except as otherwise directed in writing by the Engineer. Seed shall be mechanically sown using approved equipment. Application rates shall be checked periodically using approved methods. When drill seeding, provisions shall be made to assure overlap. If inspection shows strips have been missed or skipped, these areas will be reseeded at no additional cost. When delays in operation or unfavorable weather conditions indicate that seeding will not have satisfactory results, the Engineer will stop the work.

Only in areas where drill seeding equipment is unable to perform the work required, broadcast seeding shall be allowed at a 20% increase in application rate. Mechanical spreaders, landscape seeders, fertilizer spreaders, or other mechanical spreading equipment may be used. The area shall be raked or dragged after seed placement to the satisfaction of the Engineer prior to placement of mulch.

#### A. *BROADCAST SEEDING*

Seed shall be broadcast by approved sowing equipment or by hand for small areas or on extreme slopes. Seed shall be uniformly distributed with half the seed being sown with the sower moving in one direction, and the remaining half-sown at right angles to the first sowing. Seed shall be covered to an average depth of 1/2 inch by a harrow or approved device. Broadcast seeding will not be allowed in windy conditions.

#### B. *DRILL SEEDING*

Drill seeding shall be done with grass drills not more than 6 inches apart and shall be sown uniformly over the designated area. Seed shall be sown to an average depth of 1/2 inch.

#### C. *HYDROSEEDING*

Hydroseeding will be allowed only when specified. The seed, water and mulch (if specified) shall be combined and kept under constant agitation so that a slurry of seed, mulch (if required) and fertilizer and water can be applied hydraulically to the areas to be seed. The equipment used will provide sufficient agitation to insure a uniform mixture of the ingredients throughout the application of each given quantity of slurry mixture.

Uniform coverage and seeding ratios shall be obtained and spot checks of seed distribution may be made by random placing of paper plates on areas to be seeded. After seeding, comparison of actual count of seed on the plates will verify the uniformity and application rate of the seeding distribution. Hydroseeding will not be allowed after September 15<sup>th</sup>.

### 3.5. SEEDING SEASONS

All seedbed preparation and seeding shall be done between the dates of April 15<sup>th</sup> and July 1<sup>st</sup> or between the dates of August 15<sup>th</sup> and September 15<sup>th</sup> or the contract deadline, whichever occurs first.

Any planting done between the dates of July 1<sup>st</sup> and August 15<sup>th</sup> will be allowed only with prior written permission of the Engineer and will be at the Contractor's own risk. The addition of 10 pounds of oats per acre to the specified amount of seed shall be added at no additional cost to the city. If the seeding fails to produce a uniform growth the seeding shall be repeated until the required growth is achieved.

Dormant fall seeding will be allowed with approval from the Engineer. Typical times of dormant seeding are from late October to early November with the soil in a cool condition. No seed shall be sown on frozen ground.

### 3.6. MULCHING

#### *A. MULCHING – TYPE 1 (HYDRO MULCH)*

Hydro mulch shall be uniformly applied to cover the entire seedbed area up to 95%. The mulch shall permit the percolation of water to the underlying soil.

Mix specified fiber mulch with fiber-mulch manufacturer's recommended tackifier in water using equipment specifically designed for hydromulch application. Continue mixing until uniformly blended into homogeneous slurry suitable for hydraulic application.

Hydraulic seeding equipment shall be capable of maintaining a continuous agitation so that a homogeneous mixture can be applied through a spray nozzle. The pump shall be capable of producing sufficient pressure to maintain a continuous, non-fluctuating spray

capable of reaching the extremities of the seeding area with the pump unit located on the roadbed and applying the slurry under pressure to the designated area. Sufficient hose shall be provided to reach areas not practical to seed from the nozzle unit situated on the roadbed.

The Contractor, at his own expense, shall clean all fixtures, buildings, sidewalks and other areas that may receive unwanted mulch spray.

*B. MULCHING – TYPE 2 (STRAW MULCH)*

Mulch shall be placed within 24 hours after the seeding has been completed. Mulching shall not be performed during periods of high winds. Mulch shall be applied uniformly over the seeded area by a mechanical blower that minimizes cutting or breaking of the material. Bales shall be broken up and loosened as they are fed into the blower to avoid placement of matted or unbroken lumps. The mulch shall be anchored by punching with a mulch tiller that anchors the mulch approximately 3 inches into the soil while leaving approximately 10% of the soil surface exposed. Excessive cover not anchored into the soil shall be removed by the Contractor at his own expense. Rutting of slopes during mulching process shall be immediately repaired by the Contractor.

3.7. WEED CONTROL

3.7.1. Regulations

A. General

Herbicide applications will be performed according to federal, state, and local regulations. Herbicide products shall be used consistent with their labeling. Herbicide applications will be pursued as a vegetation management tool when needed. All herbicide products, mixes and applications must be approved by the Engineer. Applicators must use extreme caution when applying herbicides near water, adjacent properties with crops that might be damaged, or other landscaped areas.

B. Herbicide Applications

The Contractor making the application is responsible for the purchase, storage, record keeping and disposal of herbicides. Herbicides will only be applied by qualified applicators, following herbicide labels and manufacturers recommendation for application rates. A qualified applicator is an individual who has been trained regarding the product and application method, and meets any federal, state, and local laws and regulations. This individual is required to hold a certified applicators license, or be under the direct supervision of a certified applicator. Supervisors of qualified applicators are required to hold a certified applicators license in the state of North Dakota.

C. Herbicide Reports

All herbicide applications will be reported to the Engineer using the Contractor's herbicide report. Reports will be submitted to the Engineer on a weekly basis. It is the herbicide Contractor's responsibility to maintain reports for review by the State Department of Agriculture.

*3.7.2. Application*

A. Type A – Non-Selective Herbicide

Shall be uniformly applied at the rate as labeled by the manufacturer prior to soil preparation to reduce organic materials, to areas requested and designated by the Engineer to control unwanted vegetation.

B. Type B – Selective Herbicide

Shall be uniformly applied at the rate as labeled by the manufacturer after seed germination during turf establishment to reduce broad leaf weeds to areas requested and designated by the Engineer to control unwanted vegetation.

3.8. CLEANUP

All areas shall be cleaned of debris that may hinder maintenance operations and all paved areas over which hauling operations were conducted shall be cleaned of soil or other material that may have been brought upon the surface.

### 3.9. MAINTENANCE & PROTECTION OF SEEDED AREA

The Contractor shall protect all seeded areas from traffic by placing warning signs or erecting barricades immediately after seeding is complete. Any damage that may occur prior to final acceptance by the Engineer shall be repaired to re-establish the conditions or grade of the soil prior to the damage and shall then be re-planted by the Contractor at no additional cost.

The Contractor shall repair erosion-damaged areas. Damaged areas shall be re-graded, seeded & mulched.

The Contractor shall control growth of weeds by applying herbicides in accordance with the manufacturer's instructions. Mowing shall be done by the Contractor at no cost to the city prior to final acceptance of seeding.

### 3.10. WATERING OF SEEDED AREA

Immediately upon completion of the seeding and mulching, the seeded areas shall be given sufficient watering to moisten the seedbed to a depth of 2 inches. Water shall be applied in a manner that provides uniform coverage and prevents erosion and damage to the final surface. The Contractor shall provide daily watering for the first five days and sufficient water to maintain surface moisture in the top 2 inches of the soil until such time as the grass (not cover crop) has been evenly established to a height of 2". After the Engineer determines the terms of the contract have been met with regard to watering, the Contractor shall notify adjacent residents/property owners of the transfer of watering responsibility, using Form G7 which is provided on the City's website.



**PART 4**  
**GUARANTEE, MEASUREMENT & PAYMENT**

4.1. GUARANTEE

The guarantee shall cover the contract as to workmanship and material for a period of nine (9) months from the date of final acceptance and payment.

4.2. MEASUREMENT

Measurement will be done once to determine both seeding and mulching quantities by measuring the areas seeded. Overspray or over-application of mulch beyond seeded areas will not be paid. Refer to the bid sheet for the unit of measurement.

4.3. PAYMENT

*4.3.1. SEEDING*

Seeding will be paid for at the contract unit price, and shall be full compensation for preparing the earth bed, furnishing and applying both applications of fertilizer, furnishing and placing the seed, watering of the seedbed, and all labor, equipment, tools and incidentals necessary to complete the work in accordance with these Specifications.

50% of the seeding quantity will be paid at the completion of seeding. The remaining 50% will be paid when grass has been evenly established to a height of 2".

Contractors shall notify the Engineer prior to all seeding and/or fertilizer applications so an Engineer's representative may be present to collect seed tags and/or verify application rates. Failure to do so may result in reduced or non-payment for the work.

*4.3.2. MULCH*

All labor, equipment, tools, and incidentals necessary to place the mulch shall be included in the appropriate contract unit price.

A. *MULCHING – TYPE 1 (HYDRO MULCH)*

When hydro seeding with mulch is specified, the cost of the mulch shall be included in the contract unit price for hydro seeding. If hydro mulching is a separate bid item it will be paid for at the contract unit price.

B. *MULCHING – TYPE 2 (STRAW MULCH)*

Straw mulch when specified will be paid for at the contract unit price for the area covered by the mulch.

4.3.3. *WEED CONTROL (TYPE A & TYPE B)*

All labor, material, equipment, tools, and incidentals necessary to apply herbicides shall be included in the appropriate contract unit price.

4.3.4. *OTHER COSTS*

All other costs for work necessary to properly complete the work specified herein shall not be bid items; the costs shall be charged to other items unless a bid item is specifically included on the bid sheet.

**CITY OF FARGO SPECIFICATIONS  
TURF ESTABLISHMENT**

**PART 1  
DESCRIPTION OF WORK**

This work to be done under this section of the Specifications and the accompanying plans consists of establishing turf on boulevards, slopes, ditches, or other locations shown on the plans or as designated by the Engineer.

**PART 2**  
**MATERIAL**

2.1. TOPSOIL

All topsoil shall meet the requirements specified in Section 2000 of these Specifications.

2.2. SEED

All seed shall be labeled in accordance with U. S. Department of Agriculture rules and regulations under the Federal Seed Act in effect on the date of the invitation to bids. Seed shall be furnished separately or in mixture in standard sealed containers. Damaged, wet, or moldy seed will not be accepted. All seed shall meet the minimum requirements for purity and germination. No purity or germination tolerance will be allowed. Weed seed shall not exceed 0.5% of the total mixture, and seed shall contain no noxious weed seed of the state from which seed is to be shipped.

Seed tags shall be provided with each bag of seed used on the project and shall be given to the Engineer. Seed certifications from seed supplier shall be provided upon request. Labels for seed shall contain the following:

1. Name and address of supplier
2. Lot number
3. Seed name and origin for each kind of seed
4. Percentages of purity and of germination for each kind of seed & percentage of weed seed content in the mixture.
5. Date of last test
6. Pounds of bulk seed for total mix in each bag

Seed mixtures shall conform to the following types:

A. Type A - Ditches and Side Slopes:

<u>Kind Of Seed</u>	<u>Percentage</u>		
	<u>by Weight</u>	<u>Purity</u>	<u>Germination</u>
Meadow Brome Grass	30%	85%	85%
Intermediate Wheatgrass	30%	90%	85%
Crested Wheatgrass	30%	90%	85%
Tetraploid Int. Perennial Ryegrass	10%	95%	85%

Rate of Seeding = 75 Pounds per Acre

Seed mixture shall contain one of the following companion crops at the specified application rate:

1. April 1 to June 15 seeding – 15 pounds/acre of Oats.
2. June 15 to August 15 seeding – 8 pounds/acre of Millet.
3. August 15 to December 1 seeding – 15 pounds/acre of Rye or Winter Wheat.

B. Type B - Parks, Boulevards, Private Property, Built-Up Areas:

<u>Kind Of Seed</u>	<u>Percentage</u>		
	<u>by Weight</u>	<u>Purity</u>	<u>Germination</u>
Kentucky Bluegrass	60%	90%	85%
Creeping Red Fescue	10%	90%	85%
Fine Leaf Perennial Ryegrass	30%	95%	90%

Percent by weight shall be plus or minus 5 % on all seed types.

Rate of Seeding = 220 Pounds Per Acre (5 Pounds Per 1,000 Sq. Ft.)

C. Type C - Other Applications:

See the Special Instructions for the seed mix design and application rate.

2.3. FERTILIZER

Fertilizer shall be a standard commercial grade product, free flowing and suitable for application with mechanical equipment, delivered in clean, sealed, moisture-proof & properly labeled containers bearing the name, trade name or trade mark and warranty of the producer. Fertilizers shall be recommended for grass, supplied separately or in mixtures. Fertilizer shall conform to all State and Federal regulations. All fertilizer shall contain slow release nitrogen in the form of inorganic chemicals amounting to at least 50% of the available nitrogen specified.

A. Type A & Type B Seeding:

Starter Fertilizer: Fertilizer shall be 12-24-12 at an application rate of 220 pounds per acre (5 pounds per 1,000 sq. Ft.).

Turf Fertilizer: Fertilizer shall be 24-24-4 at an application rate of 110 pounds per acre (2.5 pounds per 1,000 sq. Ft.).

B. Type C Seeding:

Fertilizer design and application rates will be as specified in the Special Instructions.

2.4. MULCH

A. *MULCHING – TYPE 1 (HYDRO MULCH)*

Hydro mulch shall be virgin wood fiber mulch for use in hydraulic planting, cooked cellulose fiber which shall have the property of dispersing readily in water and shall have no toxic effect when combined with seed or other materials. The mulch shall be treated with a tackifier to enhance mulch placement and adherence to the soil. A green colored dye which is non toxic to plant growth shall be used. Wood cellulose fiber shall be packaged in new, labeled containers, shall have an equilibrium air-dried moisture content of 12% plus or minus 3% at time of manufacture, and shall have a pH range of 3.5 to 5.0. No sawdust or byproduct mulch will be allowed. The homogenous slurry or mixture shall be capable of application with power spray equipment. Hydromulch shall be applied at a rate of 2,000 pounds per acre (45 pounds per 1,000 sq. Ft.).

B. *MULCHING – TYPE 2 (STRAW MULCH)*

Material for straw mulching shall be threshed stalks of native oats, wheat, barley or rye, and shall be weed free to prevent the introduction of noxious weeds as defined by the North Dakota Department of Agriculture. At least 50% of the mulch by weight shall be 10 inches or more in length. Musty, moldy, caked or otherwise low quality straw is not acceptable. Dry mulching material that breaks and does not bend is not acceptable. Hay or chopped cornstalks are not acceptable. Application rate is 2 tons per acre (90 pounds per 1,000 sq. Ft.).

2.5. WEED CONTROL

- A. Type A – Non-Selective Herbicide: Round-up, glyphosate or approved equal,
- B. Type B – Selective Herbicide: Trimec, 2,4-D or approved equal.

**PART 3**  
**CONSTRUCTION**

3.1. PREPARATION OF AREAS TO BE SEEDED

Prior to or during grading and tillage operations, the ground surface shall be raked and cleared of all stumps, brush, sticks, roots, stones larger than 1/2 inch in diameter, concrete chunks, rebar, wire or other material that may hinder seeding and maintenance operations. Any accumulated material shall be disposed of by the Contractor at no additional cost to the City.

If any damage by erosion or other causes has occurred after the completion of grading and before beginning the application of fertilizer, the Contractor shall repair such damage. This may include filling gullies, smoothing irregularities, and repairing other incidental damage.

Areas that may be weedy, un-worked, or packed hard, shall first have any grass and weeds cut & disposed. The seed bed shall be disked or cultivated to a minimum depth of 3". A harrow or cultipack shall be used so that the bed is firm and the seed can be placed at the proper depth. The seed bed shall be smooth and firm, and all lumps or clods exposed shall be broken up to an inch in diameter or less.

3.2. TOPSOIL PLACEMENT

Topsoil placement shall be in accordance with Section 2000 of these Specifications.

3.3 FERTILIZING

Starter Fertilizer: Either immediately prior to or after seeding, Starter Fertilizer conforming to the above requirements shall be applied at the rate specified above and raked into the soil.

Turf Fertilizer: When the grass has been evenly established to a height of 2", or eight weeks after the Starter Fertilizer application, whichever occurs sooner, Turf Fertilizer conforming to the above requirements shall be applied at the rate specified above. Contractor shall water the turf immediately after application of Turf Fertilizer.



### 3.4. PLANTING SEED

Prior to planting of the seed, fertilizer shall be applied at the specified rate & shall be incorporated into the soil to a minimum depth of two inches. All seeding shall be done when the ground is open, not frozen or covered with snow, except as otherwise directed in writing by the Engineer. Seed shall be mechanically sown using approved equipment. Application rates shall be checked periodically using approved methods. When drill seeding, provisions shall be made to assure overlap. If inspection shows strips have been missed or skipped, these areas will be reseeded at no additional cost. When delays in operation or unfavorable weather conditions indicate that seeding will not have satisfactory results, the Engineer will stop the work.

Only in areas where drill seeding equipment is unable to perform the work required, broadcast seeding shall be allowed at a 20% increase in application rate. Mechanical spreaders, landscape seeders, fertilizer spreaders, or other mechanical spreading equipment may be used. The area shall be raked or dragged after seed placement to the satisfaction of the Engineer prior to placement of mulch.

#### A. *BROADCAST SEEDING*

Seed shall be broadcast by approved sowing equipment or by hand for small areas or on extreme slopes. Seed shall be uniformly distributed with half the seed being sown with the sower moving in one direction, and the remaining half-sown at right angles to the first sowing. Seed shall be covered to an average depth of 1/2 inch by a harrow or approved device. Broadcast seeding will not be allowed in windy conditions.

#### B. *DRILL SEEDING*

Drill seeding shall be done with grass drills not more than 6 inches apart and shall be sown uniformly over the designated area. Seed shall be sown to an average depth of 1/2 inch.

#### C. *HYDROSEEDING*

Hydroseeding will be allowed only when specified. The seed, water and mulch (if specified) shall be combined and kept under constant agitation so that a slurry of seed, mulch (if required) and fertilizer and water can be applied hydraulically to the areas to be seed. The equipment used will provide sufficient agitation to insure a uniform mixture of the ingredients throughout the application of each given quantity of slurry mixture.

Uniform coverage and seeding ratios shall be obtained and spot checks of seed distribution may be made by random placing of paper plates on areas to be seeded. After seeding, comparison of actual count of seed on the plates will verify the uniformity and application rate of the seeding distribution. Hydroseeding will not be allowed after September 15<sup>th</sup>.

### 3.5. SEEDING SEASONS

All seedbed preparation and seeding shall be done between the dates of April 15<sup>th</sup> and July 1<sup>st</sup> or between the dates of August 15<sup>th</sup> and September 15<sup>th</sup> or the contract deadline, whichever occurs first.

Any planting done between the dates of July 1<sup>st</sup> and August 15<sup>th</sup> will be allowed only with prior written permission of the Engineer and will be at the Contractor's own risk. The addition of 10 pounds of oats per acre to the specified amount of seed shall be added at no additional cost to the city. If the seeding fails to produce a uniform growth the seeding shall be repeated until the required growth is achieved.

Dormant fall seeding will be allowed with approval from the Engineer. Typical times of dormant seeding are from late October to early November with the soil in a cool condition. No seed shall be sown on frozen ground.

### 3.6. MULCHING

#### *A. MULCHING – TYPE 1 (HYDRO MULCH)*

Hydro mulch shall be uniformly applied to cover the entire seedbed area up to 95%. The mulch shall permit the percolation of water to the underlying soil.

Mix specified fiber mulch with fiber-mulch manufacturer's recommended tackifier in water using equipment specifically designed for hydromulch application. Continue mixing until uniformly blended into homogeneous slurry suitable for hydraulic application.

Hydraulic seeding equipment shall be capable of maintaining a continuous agitation so that a homogeneous mixture can be applied through a spray nozzle. The pump shall be capable of producing sufficient pressure to maintain a continuous, non-fluctuating spray

capable of reaching the extremities of the seeding area with the pump unit located on the roadbed and applying the slurry under pressure to the designated area. Sufficient hose shall be provided to reach areas not practical to seed from the nozzle unit situated on the roadbed.

The Contractor, at his own expense, shall clean all fixtures, buildings, sidewalks and other areas that may receive unwanted mulch spray.

*B. MULCHING – TYPE 2 (STRAW MULCH)*

Mulch shall be placed within 24 hours after the seeding has been completed. Mulching shall not be performed during periods of high winds. Mulch shall be applied uniformly over the seeded area by a mechanical blower that minimizes cutting or breaking of the material. Bales shall be broken up and loosened as they are fed into the blower to avoid placement of matted or unbroken lumps. The mulch shall be anchored by punching with a mulch tiller that anchors the mulch approximately 3 inches into the soil while leaving approximately 10% of the soil surface exposed. Excessive cover not anchored into the soil shall be removed by the Contractor at his own expense. Rutting of slopes during mulching process shall be immediately repaired by the Contractor.

3.7. WEED CONTROL

3.7.1. Regulations

A. General

Herbicide applications will be performed according to federal, state, and local regulations. Herbicide products shall be used consistent with their labeling. Herbicide applications will be pursued as a vegetation management tool when needed. All herbicide products, mixes and applications must be approved by the Engineer. Applicators must use extreme caution when applying herbicides near water, adjacent properties with crops that might be damaged, or other landscaped areas.

B. Herbicide Applications

The Contractor making the application is responsible for the purchase, storage, record keeping and disposal of herbicides. Herbicides will only be applied by qualified applicators, following herbicide labels and manufacturers recommendation for application rates. A qualified applicator is an individual who has been trained regarding the product and application method, and meets any federal, state, and local laws and regulations. This individual is required to hold a certified applicators license, or be under the direct supervision of a certified applicator. Supervisors of qualified applicators are required to hold a certified applicators license in the state of North Dakota.

C. Herbicide Reports

All herbicide applications will be reported to the Engineer using the Contractor's herbicide report. Reports will be submitted to the Engineer on a weekly basis. It is the herbicide Contractor's responsibility to maintain reports for review by the State Department of Agriculture.

*3.7.2. Application*

A. Type A – Non-Selective Herbicide

Shall be uniformly applied at the rate as labeled by the manufacturer prior to soil preparation to reduce organic materials, to areas requested and designated by the Engineer to control unwanted vegetation.

B. Type B – Selective Herbicide

Shall be uniformly applied at the rate as labeled by the manufacturer after seed germination during turf establishment to reduce broad leaf weeds to areas requested and designated by the Engineer to control unwanted vegetation.

3.8. CLEANUP

All areas shall be cleaned of debris that may hinder maintenance operations and all paved areas over which hauling operations were conducted shall be cleaned of soil or other material that may have been brought upon the surface.

### 3.9. MAINTENANCE & PROTECTION OF SEEDED AREA

The Contractor shall protect all seeded areas from traffic by placing warning signs or erecting barricades immediately after seeding is complete. Any damage that may occur prior to final acceptance by the Engineer shall be repaired to re-establish the conditions or grade of the soil prior to the damage and shall then be re-planted by the Contractor at no additional cost.

The Contractor shall repair erosion-damaged areas. Damaged areas shall be re-graded, seeded & mulched.

The Contractor shall control growth of weeds by applying herbicides in accordance with the manufacturer's instructions. Mowing shall be done by the Contractor at no cost to the city prior to final acceptance of seeding.

### 3.10. WATERING OF SEEDED AREA

Immediately upon completion of the seeding and mulching, the seeded areas shall be given sufficient watering to moisten the seedbed to a depth of 2 inches. Water shall be applied in a manner that provides uniform coverage and prevents erosion and damage to the final surface. The Contractor shall provide daily watering for the first five days and sufficient water to maintain surface moisture in the top 2 inches of the soil until such time as the grass (not cover crop) has been evenly established to a height of 2". After the Engineer determines the terms of the contract have been met with regard to watering, the Contractor shall notify adjacent residents/property owners of the transfer of watering responsibility, using Form G7 which is provided on the City's website.

**PART 4**  
**GUARANTEE, MEASUREMENT & PAYMENT**

4.1. GUARANTEE

The guarantee shall cover the contract as to workmanship and material for a period of nine (9) months from the date of final acceptance and payment.

4.2. MEASUREMENT

Measurement will be done once to determine both seeding and mulching quantities by measuring the areas seeded. Overspray or over-application of mulch beyond seeded areas will not be paid. Refer to the bid sheet for the unit of measurement.

4.3. PAYMENT

*4.3.1. SEEDING*

Seeding will be paid for at the contract unit price, and shall be full compensation for preparing the earth bed, furnishing and applying both applications of fertilizer, furnishing and placing the seed, watering of the seedbed, and all labor, equipment, tools and incidentals necessary to complete the work in accordance with these Specifications.

50% of the seeding quantity will be paid at the completion of seeding. The remaining 50% will be paid when grass has been evenly established to a height of 2".

Contractors shall notify the Engineer prior to all seeding and/or fertilizer applications so an Engineer's representative may be present to collect seed tags and/or verify application rates. Failure to do so may result in reduced or non-payment for the work.

*4.3.2. MULCH*

All labor, equipment, tools, and incidentals necessary to place the mulch shall be included in the appropriate contract unit price.

A. *MULCHING – TYPE 1 (HYDRO MULCH)*

When hydro seeding with mulch is specified, the cost of the mulch shall be included in the contract unit price for hydro seeding. If hydro mulching is a separate bid item it will be paid for at the contract unit price.

B. *MULCHING – TYPE 2 (STRAW MULCH)*

Straw mulch when specified will be paid for at the contract unit price for the area covered by the mulch.

4.3.3. *WEED CONTROL (TYPE A & TYPE B)*

All labor, material, equipment, tools, and incidentals necessary to apply herbicides shall be included in the appropriate contract unit price.

4.3.4. *OTHER COSTS*

All other costs for work necessary to properly complete the work specified herein shall not be bid items; the costs shall be charged to other items unless a bid item is specifically included on the bid sheet.

**CITY OF FARGO SPECIFICATIONS  
SODDING**

**PART 1  
DESCRIPTION OF WORK**

This work to be done under this section of the Specifications and the accompanying plans consists of the furnishing and laying of live sod on the slopes, ditches, boulevards, or other locations shown on the plans or as designated by the Engineer.



**PART 2**  
**MATERIAL**

2.1. TOPSOIL

All topsoil shall be black sandy loam. It shall be free from surface vegetation, objectionable weeds, and shall be free from lumps, stones or other debris.

2.2. SOD

Sod shall consist of a dense well-rooted growth of permanent and desirable grasses native to the general locality, and shall be free of weeds and undesirable grasses. At the time the sod is cut, the grass shall have a length of approximately 2 inches. The sod shall be free of grass clippings and shall be well moistened to prevent crumbling or breaking during cutting operations. The thickness shall be as uniform as possible, approximately 1 1/2 inches or more, depending on the nature of the sod, so that practically all of the dense root system of the grasses will be retained and exposed. The sod strip will be cut in uniform strips and will be able to be handled without undue tearing or handling. Peat sod containing more than 20% organic material will not be allowed.

2.3. FERTILIZER

Fertilizer shall be a commercial product and shall be 10-10-10 at an application rate of 220 pounds per acre (5 pounds per 1,000 sq. Ft.). Fertilizer shall be free flowing and suitable for application with mechanical equipment, delivered in sealed containers, fully labeled, and bearing the name, trade name or trade mark and warranty of the producer.

2.4. EQUIPMENT

The equipment shall be readily adaptable to the work. Small tractors, rakes and hand equipment of the lawn and garden type will be acceptable for this work.

**PART 3**  
**CONSTRUCTION**

3.1. PREPARATION OF THE SOD BED

The area to be sodded shall have been previously constructed to the required cross section and contour, in accordance with Section #2000 for excavation and subgrade preparation. When required, boulevard filling shall be done in accordance with Section # 2000, Part 3, Section 3.7. The area to be sodded shall be free from stones, roots, or other undesirable material.

The soil shall be loosened and brought to a reasonably fine granular texture, to a depth of not less than 1 inch by means of equipment or hand methods adapted to the purpose. When abutting existing grass or sod, the existing grass/sod shall be removed using a method that provides a straight edge of sufficient depth to allow the new sod to be placed abutting that edge, without the presence of an unsightly ridge, and provide a smooth continuous appearance. When abutting ADA ramps, sidewalk, curb & gutter, the existing grass/sod shall be removed to a minimum width of 1.0' using a method that provides a straight edge of sufficient depth to allow the new sod to be placed abutting that edge, without the presence of an unsightly ridge, and provide a smooth continuous appearance. Areas of existing boulevard that have settled or where the existing boulevard is blocking drainage, the Contractor shall remove the existing sod and level the area by filling with black dirt, or by removing the excess dirt prior to placing the new sod. Approximately 24 hours prior to the sod placement, the earth bed shall be thoroughly moistened to reduce stress.

3.2. FERTILIZER

Prior to the placement of the new sod, the earth bed shall be fertilized at the specified rate.

3.3. PLACING THE SOD

The earth bed shall be moistened to the loosened depth, if not sufficiently moist, and the sod shall be placed thereon within 24 hours of being cut.

Unless otherwise required, the sod on slopes shall be laid in horizontal strips beginning at the bottom of the slope and working upward. When placing sod in ditches or in the construction of sod ditch checks or similar appurtenances, the long length of the strip shall be laid at right angles to the direction of flow of the water. Sod shall be laid so that the joints caused by the abutting

ends are not continuous. Each sod strip shall be laid so that it will fit snugly against the strip previously laid.

As the sod is being laid, it shall be rolled or firmly but lightly tamped with suitable wooden or metal tampers sufficient only to “set” or press the sod into the underlying soil.

At such points where water will start flowing over a sodded area, the upper edges of the sod strips shall be turned into the soil to be below the adjacent area, and a layer of earth placed over this juncture, which earth shall be firmly compacted to conduct the surface water over the upper edge of the sod.

At the limits of the sodded areas, where practicable or feasible, the ends of the sod strips shall be placed to effect a broken line, and the ends turned in and treated as above described. Any sod that has been frozen prior to laying, or is laid on a frozen bed, or is laid in conditions in which the sod does not establish itself during such following growing season shall be removed and replaced by the Contractor at his expense. Generally, sodding shall only be done at such time of the year when climactic conditions of temperature and moisture are most adaptable for growth. No sod shall be placed when the temperature is below 32° F.

#### 3.4. STAKING THE SOD

On all slopes steeper than 1 foot vertical to 4 feet horizontal, the sod shall be staked or pegged with pieces of lath or small stakes 12 inches in length, spaced as needed by the nature and steepness of the slope, from 18 inches to 36 inches apart along the longitudinal axis of the sod strip. Stakes shall be placed near the top of the strip and driven through and almost flush with the sod surface.

#### 3.5. WATERING OF THE SOD

The sod shall be watered immediately after placement. The Contractor shall be responsible for maintaining and daily watering of the sod for a period of two weeks after installation. Watering shall be done by sprinkling or by a method that does not allow substantial runoff from the sodded areas. Water may be obtained from the nearest City of Fargo hydrant at no cost to the Contractor; however the use of the hydrant shall be under the regulations of the City Water Department. When sod is placed on boulevards of built-up properties, the Contractor shall provide written notice to the property owner that the Contractor’s watering responsibility has expired and watering and maintenance of the new sod is being transferred to the property owner.

**PART 4**  
**GUARANTEE, MEASUREMENT & PAYMENT**

4.1. GUARANTEE

The guarantee shall cover the contract as to workmanship and material for a period of six (6) months from the date of final acceptance and payment.

4.2. METHOD OF MEASUREMENT

Measurement of the sodded area will be determined by measuring the surface area of the area sodded. The unit of measure will be the square yard. Sodding will be paid for within a width limit. Sodding limits will be as directed below or as directed by the Engineer or as shown on the plans.

When sodding is part of a street rehabilitation or reconstruction project wherein large lengths of curb are replaced, the maximum width of sodding will be 5 feet unless the boulevard is less than 6 feet wide from the back of the new curb to the front of the sidewalk, in which case the entire boulevard will be resodded.

4.3. METHOD OF PAYMENT

Sodding will be paid for at the contract unit price per square yard. The payment of the contract unit price shall be full compensation for preparing the earth bed, furnishing and applying the fertilizer, furnishing, placing, staking and watering the sod, and all labor, equipment, tools, and incidentals necessary to complete the work in accordance with these Specifications.

4.4. OTHER COSTS

All other costs for work necessary to properly complete the work specified herein shall not be bid items; the costs shall be charged to other items unless a bid item is specifically included on the bid sheet.

**CITY OF FARGO SPECIFICATIONS  
EROSION AND SEDIMENT CONTROL**

**PART 1  
DESCRIPTION OF WORK**

The work to be completed under this section of the Specifications and the accompanying plans shall include all labor, materials, and equipment necessary to provide for Erosion and Sediment control on City of Fargo projects that involve ground disturbing activity. This shall also include the preparation and maintenance of a Storm Water Pollution Prevention Plan (SWPPP) and all necessary storm water permitting and documentation.

Erosion and sediment control will include such items as temporary construction entrances, silt fence, fiber rolls, inlet protection, dewatering structures, concrete washout areas, turf establishment, and/or other items as shown on the plans. The Contractor shall be required to install erosion and sediment control measures prior to disturbing the site, where possible and to implement the remaining measures as early as practicable in accordance with the phasing of construction operations. Once installed, the Contractor shall maintain erosion and sediment control measures until they are no longer needed, or until his ND Pollutant Discharge Elimination System (NDPDES) permit responsibilities are terminated or transferred to another party.

In addition to the erosion and sediment control measures included in the plans and Specifications, the Contractor shall take measures, as appropriate, to prevent pollution resulting from work outside of the right-of-way or project area. This may include, but is not limited to such things as delivery and storage of equipment and materials, waste disposal, borrow operations, construction, and/or use of haul roads. The cost for this work or work required to rectify conditions that result from carelessness or failure to properly coordinate implementation of erosion control measures with the phasing of construction shall be the Contractor's expense.

Typical Best Management Practices are provided for in this document. The Contractor may propose to use practices that are not outlined here. These proposals are subject to approval by the Engineer.

**PART 2**  
**MATERIAL**

2.1. INLET PROTECTION

Material will vary depending on the type of protection needed.

*2.1.1. Inlet Protection Type A-1*

Fence Post- shall be metal, a minimum of 5.0” long and shall be free of excessive deformation.

Wire Mesh Reinforcement- shall be free from rust and in good general condition at the time of installation.

Geotextile Fabric shall be a woven monofilament product having a water flow rate of 100-110 gpm/sf (ASTM D-4491), a minimum 70% UV resistance (ASTM D-4355), and a minimum mullen burst rating of 300 psi (ASTM D-3786).

*2.1.2. Inlet Protection Type A-2*

2”X4” Wood Frame-shall be made from hard wood that is sturdy and free from cracking.

Geotextile Fabric shall conform to Inlet Protection Type A-1 standards.

*2.1.3. Inlet Protection Type B*

Sediment Control Barrier shall meet the requirements of the following standards: ASTM D 1893, ASTM D 792/1505, ASTM D 968, ASTM D 1248, ASTM D 1308, ASTM D 2152

Frame- shall be as specified by the supplier.

Geotextile fabric around the device shall conform to Inlet Protection Type A-1 standards.

#### 2.1.4. *Inlet Protection Type C*

A pre-assembled protection device designed for drop inlet protection.

The device shall consist of a reusable, open topped receptacle that rests inside a storm sewer inlet casting allowing the grating to be reinstalled in the casting. If needed a rear deflector plate shall be incorporated into the unit to protect open back castings from sediment. The receptacle shall have a filtration system to filter storm water. The receptacle shall also have an overflow large enough to minimize/eliminate street flooding during rain events. Approved manufacturers shall be Wimco, Lange IPD, Flexstorm, or approved equal.

#### 2.1.5. *Inlet Protection Type C-2*

Type C-2 inlet protection shall consist of a sediment collection plate meeting H20 loading per OSHA 1910.23. ¼" steel plate shall be painted yellow with a perforated steel lid. A two position HDPE basket shall be provided that is able to be fixed in the up or down position. 400 micron filter bag for basket shall be attached to filter sediment.

### 2.2. *FIBER ROLLS, ROCK LOGS & COMPOST ROLLS*

Fiber rolls shall be weed free- wheat straw, rice straw, or coconut fiber- wrapped in tubular plastic netting. Fiber rolls shall be a minimum of nine inches in diameter (+/- one inch), with a minimum length of 10 feet, overlapped 1.0' at joints and approximate weight of 1 ¼ pounds per foot. Wood stakes (2" X 2" X 24") or metal pins may be used to secure the fiber roll.

Rock logs shall be adequately sized for controlling sediment. Aggregate shall vary in size between ¼" – 1-1/2" in a fiber wrapped tube.

Compost rolls shall be comprised of a variety of feedstock including yard trimmings, wood chips, leaves or other biosolids.

2.3. SILT FENCE

Geotextile Fabric shall be a woven monofilament product having a water flow rate of 100-110 gpm/sf (ASTM D-4491), a minimum 70% UV resistance (ASTM D-4355), and a minimum mullen burst rating of 300 psi (ASTM D-3786).

Posts shall be metal, and shall be a minimum of 5.0' in height free from excessive deformation.

2.4. CONCRETE WASHOUT

Barrier Fence- may use snow fence or silt fence. Purpose is to prevent easy access to excavated area.

9" Fiber Rolls (as described in Section 3300 2.2)

2.5. TEMPORARY CONSTRUCTION ENTRANCE

Crushed Rock- average diameter ranging from 1" to 2" or equivalent sized crushed concrete.

Wood Material- shall be coarse grade consisting of shredded bark of wood ground so that 95% of the material passes through a 5-inch sieve and no more than 45% through a ¾-inch sieve. Wood shall not contain material that would be harmful to equipment nor shall it contain compounds in quantities detrimental to animal, plant life or water quality. The material will have a bulk density of less than 22.2 lbs per cubic foot.

2.6. DEWATERING STRUCTURES

Material will vary depending on the Type of protection needed.

*2.6.1. Dewatering Structure Type 1*

¼ inch average diameter Pea Gravel

Fiber Roll (As described in Section 3300 2.2) or Silt Fence (As described in Section 3300 2.3).



2.6.2. *Dewatering Structure Type 2*

Geotextile Fabric – shall have a minimum water flow rate of 8 gpm/sf (ASTM D-4491), a minimum 80% UV resistance (ASTM D-4355), and a minimum mullen burst rating of 300 psi (ASTM D-3786).

Rip Rap- 12”-18” inch minimum diameter rock.

Aggregate – 3/16” average diameter rock.

Stakes shall be a minimum of 5’ in height and shall be comprised of hard wood that is sturdy and free from cracking.

2.6.3. *Dewatering Structure Type 3*

Sediment Filter Bag – Non-woven geotextile material of appropriate size and flow characteristics to treat the capacity of water being pumped. To be determined by manufacturer specifications in accordance with the pump being used.

**PART 3**  
**CONSTRUCTION**

SEASONAL CONSIDERATIONS

All devices that are installed in a street section and are determined to have the potential to cause damage to snow removal equipment shall be removed by November 1<sup>st</sup> and reinstalled as directed by the Engineer in the spring. This work is considered normal maintenance and the Contractor shall not be entitled to additional compensation.

3.1. INLET PROTECTION

Newly installed storm sewer inlets shall be protected from sediment – laden runoff by installation of an inlet protection device within a maximum of 48 hours after installation. Under no circumstance shall inlets remain unprotected over a weekend. In addition, existing inlets that will receive water from the construction site shall be protected prior to commencing land disturbing activities.

*3.1.1. Inlet Protection Type A-1*

This shall consist of installing standard preassembled wire mesh reinforced geotextile fabric around inlets. Metal fence posts shall be used to support wire mesh and geotextile fabric. Posts spacing shall not exceed 3 feet. Care must be taken to ensure the assembly provides for the wire mesh and geotextile fabric to be securely in contact with the existing ground to prevent sediment laden water from running under the device. (See Drawing 6.1 Section 3300)

This device is intended primarily to protect inlets within the future paving section and is generally disposable upon removal. It will be the responsibility of the Contractor to remove materials as directed by the Engineer. Disposal shall be the Contractor's responsibility.

*3.1.2. Inlet Protection Type A-2*

This shall consist of installing geotextile fabric securely fastened to a wooden 2”X4” frame or a prefabricated frame. Care must be taken to ensure that the assembly provides

for the geotextile fabric to be securely in contact with the existing ground to prevent sediment laden water from running under the device. (See Drawing 6.2 Section 3300)

This device is required around all inlets that are not in a street section, such as rear yard inlets. This device remains on site requiring maintenance by the Contractor throughout the project and becomes the responsibility of the developer/property owner to maintain upon final completion of the project.

#### 3.1.3. *Inlet Protection Type B*

This shall consist of installing a pre formed liner low density polyethylene barrier with a mounting frame. The frame fits into the top of the cone section of a catch basin and supports the sediment control barrier. To further protect the storm sewer from fine materials the sediment control barrier shall be wrapped with a geotextile sock approximately 2 times the circumference of the barrel. (See Drawing 6.3 Section 3300)

This device is intended primarily to protect inlets within the future paving section. The device is re-useable and may remain the property of the Contractor depending on the project. If the project includes the paving operation devices are removed following paving and become the property of the Contractor responsible for the initial installation. However, if the paving is to be done on a separate project devices need to remain until the paving process is done and will then become the property of the City and will be delivered by the Contractor to a location specified by the Engineer.

#### 3.1.4. *Inlet Protection Type C*

This shall consist of installing a prefabricated drop in inlet protection device. This shall be installed by inserting the device into the casting and replacing the grate into the frame. This device is required in all inlets that receive water from the project area that are in a street section. (See Drawing 6.4 Section 3300)

This device remains on site requiring maintenance by the Contractor throughout the project and becomes the responsibility of the developer/property owner to maintain upon final completion of the project.

### 3.1.5. *Inlet Protection Type C-2*

This shall consist of installing a prefabricated plate that will fit into the top of the cone section of a catch basin or manhole. To further protect the storm sewer from fine materials the sediment control plate shall include a 400 micron filter bag around the collection basket.

This device is intended to protect inlets within the future paving section. The device is re-useable and shall remain the property of the Contractor.

### 3.2. *FIBER ROLLS, ROCK LOGS & COMPOST ROLLS*

Fiber rolls, rock logs & compost rolls shall be installed as shown on the plans and/or as directed by the Engineer. They shall be placed on contour and staked with 24 inch wood stakes or metal pins, at a maximum spacing of four foot on center. The ends of adjacent rolls shall be overlapped on each other a minimum of 1.0'. (See Drawing 6.5 Section 3300)

Rolls remain on site requiring maintenance by the Contractor throughout the project. Sediment buildup shall be removed when it reaches 1/3 the height of the roll. Any ineffective rolls must be replaced immediately. An ineffective roll is a roll that has flattened out to half its original height. Upon final stabilization it will be the responsibility of the Contractor to remove materials as directed by the Engineer. Disposal shall be the Contractor's responsibility.

### 3.3. *SILT FENCE*

Excavate a 6" deep by 4" wide trench. Drive posts into ground on downstream side of fence (posts may be alternated on grades less than 2% to provide additional protection against wind damage). Posts shall have a maximum spacing of eight foot on center. Unroll fabric geotextile fabric one section at a time. Lay fabric flap in trench. Backfill with soil, and tamp the ground. Attach fabric to support posts. (See Silt Fence Detail)

Silt fence remains on site requiring maintenance by the Contractor throughout the project. Sediment buildup shall be removed when it reaches 1/3 the height of the silt fence. Any ineffective (decomposed, torn, collapsed materials) silt fences must be replaced immediately. Upon final stabilization it will be the responsibility of the Contractor to remove materials as directed by the Engineer. Disposal shall be the Contractor's responsibility.

### 3.4. CONCRETE WASHOUT

Excavate to required depth (3' to 4' depth). Install a barrier fence around excavated area. Maximum center to center spacing of fence posts for the barrier fence shall be 5'. Install 9" Fiber Roll as directed in Section 3300 3.2. (See Drawing 6.7 Section 3300)

Concrete washouts shall be cleaned by the Contractor when they reach 80% of their capacity. All material removed from the structure shall be the responsibility of the Contractor to dispose of. Under no circumstances will concrete chunks removed from the washout during cleaning be left on site for disposal. As directed by the Engineer the concrete washout shall be removed and the ground restored to a compacted, level, and vegetated state at the completion of the project.

### 3.5. TEMPORARY CONSTRUCTION ENTRANCE

Prior to placing the Engineering fabric, the areas shall be cleared of all trash and debris. Vegetation shall be removed to the ground level. Trash, debris, and removed vegetation shall be disposed of by the Contractor. The ground shall be graded to a uniform plane. Lay the Engineering fabric over the prepared area. Unrolling the fabric in the direction vehicles will be traveling. Crushed rock, crushed concrete, or wood material to be placed directly over the fabric shall be spread in the direction of traffic, longitudinally and along the alignment of the temporary construction entrance. A layer of crushed rock, crushed concrete, or wood material a minimum 6" thick shall be placed. Fabric damaged during rock placement shall be repaired by placing a new piece of fabric over the damaged area. The piece of fabric shall be large enough to cover the damaged area and provide a minimum 12" overlap on all edges. (See Drawing 6.8 Section 3300)

If buildup of soil and sediment deter the function of the temporary construction entrance, the Contractor shall immediately remove and dispose of the soil and sediment, and install additional crushed rock, crushed concrete, or wood material at the Contractor's expense. The Contractor shall maintain temporary construction entrances throughout the contract or until removed. The Contractor shall prevent displacement or migration of the surfacing. Significant depressions resulting from settlement or heavy equipment shall be repaired by the Contractor, as directed by the Engineer. Temporary construction entrances shall be repaired or replaced on the same day the damage occurs.

When no longer required as determined by the Engineer, temporary construction entrances shall be removed and disposed of by the Contractor. While the temporary construction entrance is in use, pavement shall be cleaned and sediment removed at least once a day, and as often as necessary

when directed by the Engineer. Soil and sediment or other extraneous material tracked onto existing pavement shall not be allowed to enter drainage facilities by any means, including precipitation events.

### 3.6. DEWATERING STRUCTURES

#### *3.6.1. Dewatering Structure Type 1*

Determine the appropriate size of the dewatering structure based on the discharge capacity of the pump to be used for dewatering. Find an area of established grass or prepare an area for use by removing all trash and debris. Lay Engineering fabric of appropriate size to cover the entire area to be used for dewatering. Fill the area with ¼” pea rock to a minimum depth of 6”. Surround the perimeter of the drainage area with Silt Fence or Fiber Roll. (See Drawing 6.9 Section 3300)

The dewatering structure shall be monitored during pumping activities. Should the Fiber Roll (if used) be overtopped by pumped water, all further pumping activities must cease until the dewatering area has discharged the water pumped into it. If buildup of soil and sediment deter the function of the dewatering structure, the Contractor shall immediately remove and dispose of the soil and sediment, and install additional pea rock to restore functionality. This work is considered normal maintenance and the Contractor shall not be entitled to additional compensation.

#### *3.6.2. Dewatering Structure Type 2*

Determine the appropriate size of the dewatering structure based on the discharge capacity of the pump to be used for dewatering. Excavate to required dimensions. Install straw bales butted tightly together and staked in place. Geotextile fabric should be placed as the bales are installed. Locate the pump discharge and place Rip Rap of sufficient size and depth to resist movement and prevent erosion where pumped water will enter the structure. Build a spillway out of 12”-18” diameter rocks, with a minimum of 6” depth from the top of the structure. Place a 6” thick layer of 3/16” aggregate on the inside of the spillway. (See Drawing 6.10 Section 3300)

The dewatering structure shall be monitored during pumping activities. Once the water nears the spillway pumping activities must cease until the dewatering area has discharged to the level of the excavated area. When the excavated area is filled to ½ its depth the

buildup of soil and sediment shall be removed and disposed of by the Contractor. Any decomposed, torn, or collapsed materials must be replaced immediately. This work is considered normal maintenance and the Contractor shall not be entitled to additional compensation.

### 3.6.3. *Dewatering Structure Type 3*

A prefabricated Sediment Containment Filter Bag made of non-woven geotextile material may be used to filter pumped water. The bag should be placed on an area of established grass or on a prepared 6" minimum depth aggregate base. The bag should be oriented in such a manner as to divert flow away from construction area and discharge filtered water into a swale, grass field, or secondary sediment containment system. (See Drawing 6.11 Section 3300)

The sediment containment bag shall be monitored during pumping activities. When the bag is filled (as per the manufacturers' specifications) all further pumping activities must cease until the bag has discharged the water pumped into it. If buildup of soil and sediment deter the function of the bag, the Contractor shall immediately remove and dispose of the soil and sediment, to restore functionality. This work is considered normal maintenance and the Contractor shall not be entitled to additional compensation.

## 3.7. SURFACE ROUGHENING

Using large tired equipment or tracked equipment slopes shall be roughened, as directed by the Engineer, prior to seeding and mulching. Roughening shall be achieved by driving equipment up and down the slope. (See Drawing 6.13 Section 3300)

## 3.8. EMERGENCY OPERATIONS – FLOOD FIGHT

Reasonable measures shall be taken to minimize sediment/pollution transfer to the Storm Sewer System during the emergency and post event phases.

### 3.8.1 *Inlet Protection – Under Levees*

In all instances where storm inlets are buried for flood fight activities, the Contractor must protect the inlets by removing the inlet grate and wrapping the grate with plastic and inserting the grate into the casting.

### *3.8.2 Inlet Protection – General*

Where practical, minimize sediment runoff potential to inlets not in the levee alignment with appropriate inlet protection devices.

### 3.9. *STREETS TO BE KEPT CLEAN*

Streets and highways that are being used by the Contractor and his forces to and from, as well as in the project site, shall be kept clean and dust-free at all times for the duration of the project and at project completion. A pick-up type or vacuum sweeper shall be used to sweep when necessary to comply with applicable permit requirements, and shall be made available at the request of the project inspector and/or Engineer to clean up material that is tracked onto city streets.

### 3.10. *TEMPORARY MULCHING*

Where required by the NDPDES permit, the Contractor shall mulch disturbed areas at his sole expense. Mulching shall be in accordance with the requirements for Type 2 mulching outlined in Section 3100 of these Specifications.



**PART 4**  
**PERMITTING**

The North Dakota Department of Health (NDDH) is the permitting authority for North Dakota. City storm water permits will not be required on City projects. The NDDH has divided the permit requirement into two general categories; Construction activity with land disturbance of one or more acres including those projects that disturb less than one acre but are part of a larger common plan of development that disturbs one or more acres & construction activity with land disturbance under an acre. There is a significant difference in permitting requirements between the two categories. Applications must be submitted to the NDDH 7 days in advance of the commencement of work.

4.1. PERMIT REQUIREMENTS

A. NDPDES Permit Requirements for Construction Activity With Land Disturbance Under An Acre

If the project will result in a land disturbance or total amount of exposed erodible surface of less than 1 acre, no NDPDES Permit is required unless the project is part of a larger common plan of development that disturbs one or more acres. If the Contractor feels that a disturbance of 1 acre or greater will be necessary to facilitate construction of the project, he must notify the Engineer prior to commencing work, so that appropriate procedures may be followed.

B. NDPDES Permit Requirements for Construction Activity With Land Disturbance of One Acre or More or Part of a Larger Common Plan of Development

- 1) Notice of Intent – The Contractor shall sign the Notice of Intent in conjunction with the City and be co applicant for permit coverage. By signing the proposal and completing the permit, the Contractor is a “co-permittee” with the city to ensure compliance with the terms and conditions of the NPDES general permit to discharge storm water associated with construction activity.
- 2) Storm Water Pollution Prevention Plan (SWPPP) - The Contractor with assistance from the Engineer, will prepare the SWPPP for this project. Erosion and sediment controls included in the plans and Specifications will be incorporated into the SWPPP.

The Engineer shall provide the Contractor with any additional information needed to complete the SWPPP guidance forms available from the North Dakota Department of Health. The completed SWPPP shall be provided within three (3) calendar days following the Notice of Award. Failure to do so may result in a delay issuing the Notice to Proceed without a corresponding extension of the contract completion date.

The Contractor shall include the following information in the completed SWPPP:

- a) Any proposed modifications or alterations required to facilitate the Contractor's means or methods of operation. The Engineer will have final say as to whether or not the proposed changes are acceptable.
  - b) When alternatives for various storm water protection measures are provided for, the Contractor shall indicate the alternatives intended for use on the project.
  - c) Spill prevention and response procedures.
  - d) Procedures for site inspection and maintenance
  - e) Description of sediment tracking reduction and recovery methods.
  - f) Significant materials inventory.
  - g) Locations and procedures for storage of materials, waste handling, temporary sanitary facilities, concrete washout, and debris disposal unless such information is already included in the plans and Specifications.
  - h) Signatures of all subcontractors and suppliers performing work or delivering materials to the project site.
- 3) Responsibility for compliance-The Contractor shall be responsible for all inspections, documentation, record keeping, maintenance, remedial actions and repairs of storm water protection measures required to maintain compliance with the NDPDES general permit for storm water discharge associated with construction activity by the North Dakota Department of Health. The Contractor shall be solely responsible and hold the City harmless for any fines or enforcement action levied by other agencies having jurisdiction, which result from the Contractor's actions, inactions, or negligence regarding compliance with the permit or erosion control provisions of the contract documents.

In addition, it shall be the Contractor's responsibility to ensure that all subcontractors and suppliers are aware of and comply with the terms and conditions of the permit.

- 4) Documentation- The Contractor shall have a copy of the SWPPP available on site for viewing at all times during the construction operations. Inspections and maintenance forms shall be kept current and submitted to the Engineer every two weeks. Failure to provide inspection forms shall result in delaying of the processing of pay estimates.
  
- 5) Termination of Permit Responsibilities- The Contractor shall be relieved of his permit responsibilities when the project is substantially complete, all required storm water protection measures are in place, and the permit responsibilities have been transferred to another Contractor or owner, or the site has undergone final stabilization.

**PART 5**  
**MEASUREMENT AND PAYMENT**

5.1. GUARANTEE

The Guarantee does not apply.

5.2. MEASUREMENT AND PAYMENT

Payment for all erosion/sediment control bid items shall include all equipment, material, labor necessary for installation, inspection, maintenance and removal.

5.2.1. INLET PROTECTION

Inlet protection will be paid by the number of inlets protected. Existing inlets on the project site or along a haul route located on or off the project site will be paid for as “Inlet Protection – Existing Inlet”. New inlets installed under the contract will be paid for as “Inlet Protection – New Inlet”. Inlet Protection will only be paid for once for each inlet protected, regardless of whether multiple types of devices are used on an inlet over the course of the project.

Example: 22 new inlets are installed on the project. 4 of the new inlets have Type A2 protection for the duration of the project, and the remaining 18 have Type C2 protection, then Type C protection. There are another 6 inlets located in the gutter along a haul route, so Type C protection is installed in those. On this example project, 46 devices were used, pay quantities would be:

Inlet Protection – Existing Inlet	6 EA
Inlet Protection – New Inlet	22 EA

Additional inlet protection needed due to Contractor carelessness or modifications to the anticipated phasing of construction, by the Contractor for shall not be compensated.

5.2.2. FIBER ROLLS, ROCK LOGS & COMPOST ROLLS

Rolls shall be paid per linear foot.

5.2.3. *SILT FENCE*

Silt Fence shall be paid per linear foot.

5.2.4. *CONCRETE WASHOUT*

Providing a concrete washout area shall be incidental to other concrete work. No additional compensation shall be provided for installing, maintaining or restoring a concrete washout area.

5.2.5. *TEMPORARY CONSTRUCTION ENTRANCE*

Temporary Construction Entrance shall be paid at the contract unit price per each and shall include full compensation for constructing temporary construction entrance, complete in place, including excavation, fabric and backfill, as shown on the plans, and as directed by the Engineer. Cleanup, repair, removal, disposal, or replacement due to improper installation or the Contractor's negligence will not be considered as included in the cost for performing maintenance.

5.2.6. *DEWATERING STRUCTURES*

No additional compensation shall be provided for installing, or maintaining a dewatering structure. Nor will any compensation be given for restoring the area where the dewatering structure is installed.

5.2.7. *SURFACE ROUGHENING*

No additional compensation shall be provided for surface roughening activities.

5.2.8. *STORMWATER MANAGEMENT*

Stormwater Management shall include all labor, materials, equipment, and administrative effort required to comply with the NDPDES permit requirements, including obtaining the permit, documentation, reporting, preparation of the Storm Water Pollution Prevention Plan, and implementing of any erosion and sedimentation controls not specifically identified on the plans, but required for permit compliance.

5.2.9. *SWEEPING*

Sweeping shall be considered incidental to other bid items.

5.2.10. *ADDITIONAL EROSION AND SEDIMENT CONTROL MEASURES*

In the event that the Engineer orders additional temporary or permanent erosion control measures to be implemented, due to changes in the scope of the project, or conditions that were unforeseen during design, the Contractor shall be paid for this work at the respective unit bid prices. If there is no comparable item of work, the Contractor shall be compensated in accordance with the provisions established for extra work.

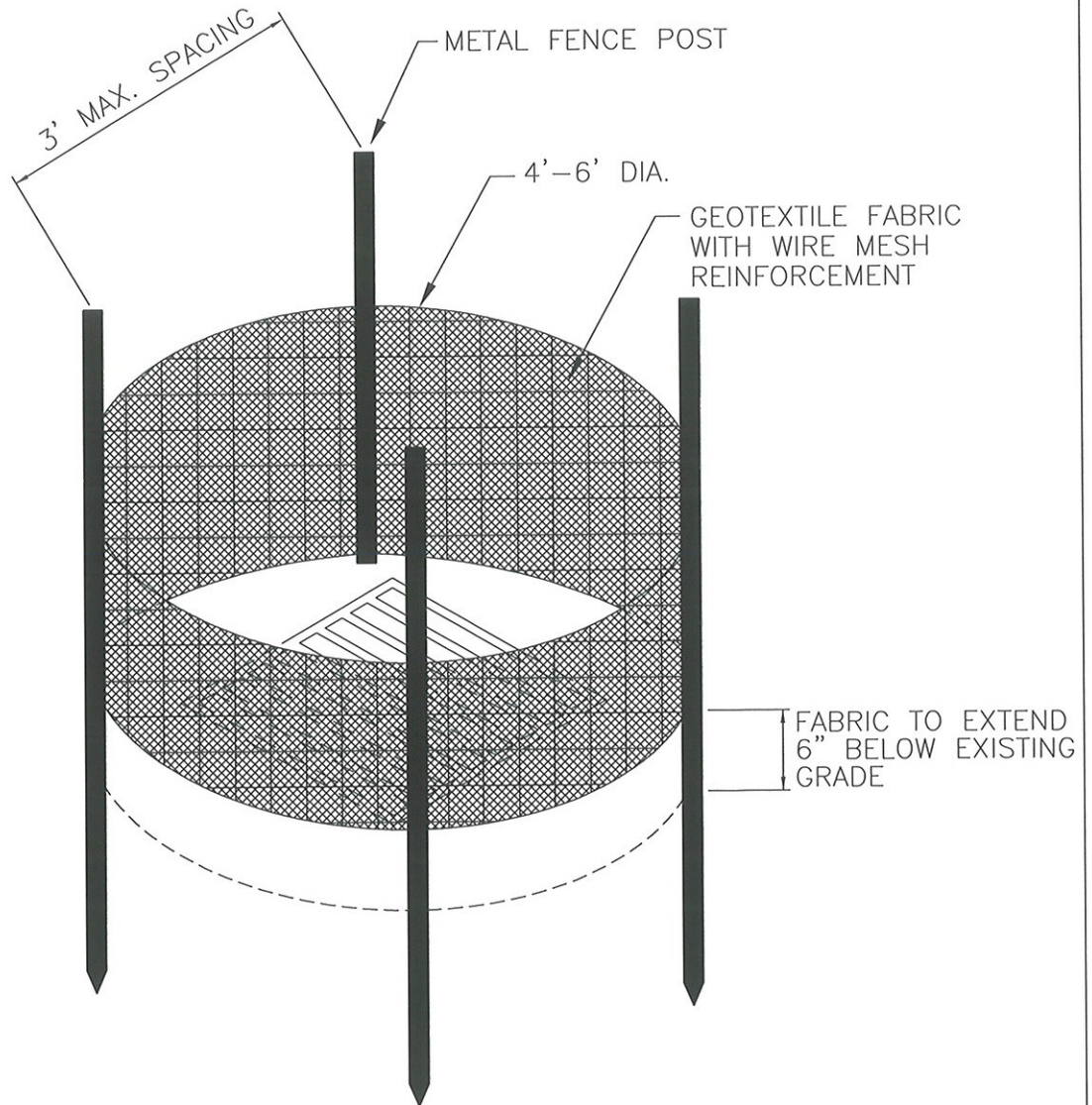

NOTES:

1. INLET PROTECTION DEVICES SHALL BE MAINTAINED OR REPLACED AT THE DIRECTION OF THE ENGINEER.
2. MANUFACTURED ALTERNATIVES MAY BE SUBSTITUTED, SUBJECT TO THE ENGINEER'S APPROVAL
3. WHEN REMOVING OR MAINTAINING INLET PROTECTION, CARE SHALL BE TAKEN SO THAT THE SEDIMENT TRAPPED ON THE GEOTEXTILE FABRIC DOES NOT FALL INTO THE INLET. ANY MATERIAL FALLING INTO THE INLET SHALL BE REMOVED IMMEDIATELY.
4. FABRIC SHALL BE INSTALLED IN ONE CONTINUOUS PIECE WRAPPED AROUND POSTS, OVERLAPPED ACROSS THE LAST GAP, ITS ENDS SECURELY FASTENED TO SEPARATE POSTS.

SECTION NO. 3300	DRAWING NO. 6.1
REV.D. 2013	
<i>STORM SEWER INLET PROTECTION: TYPE A-1</i>	
CITY OF FARGO ENGINEERING DEPARTMENT	
APPROVED <i>CME</i>	DATE <i>1-2-13</i>

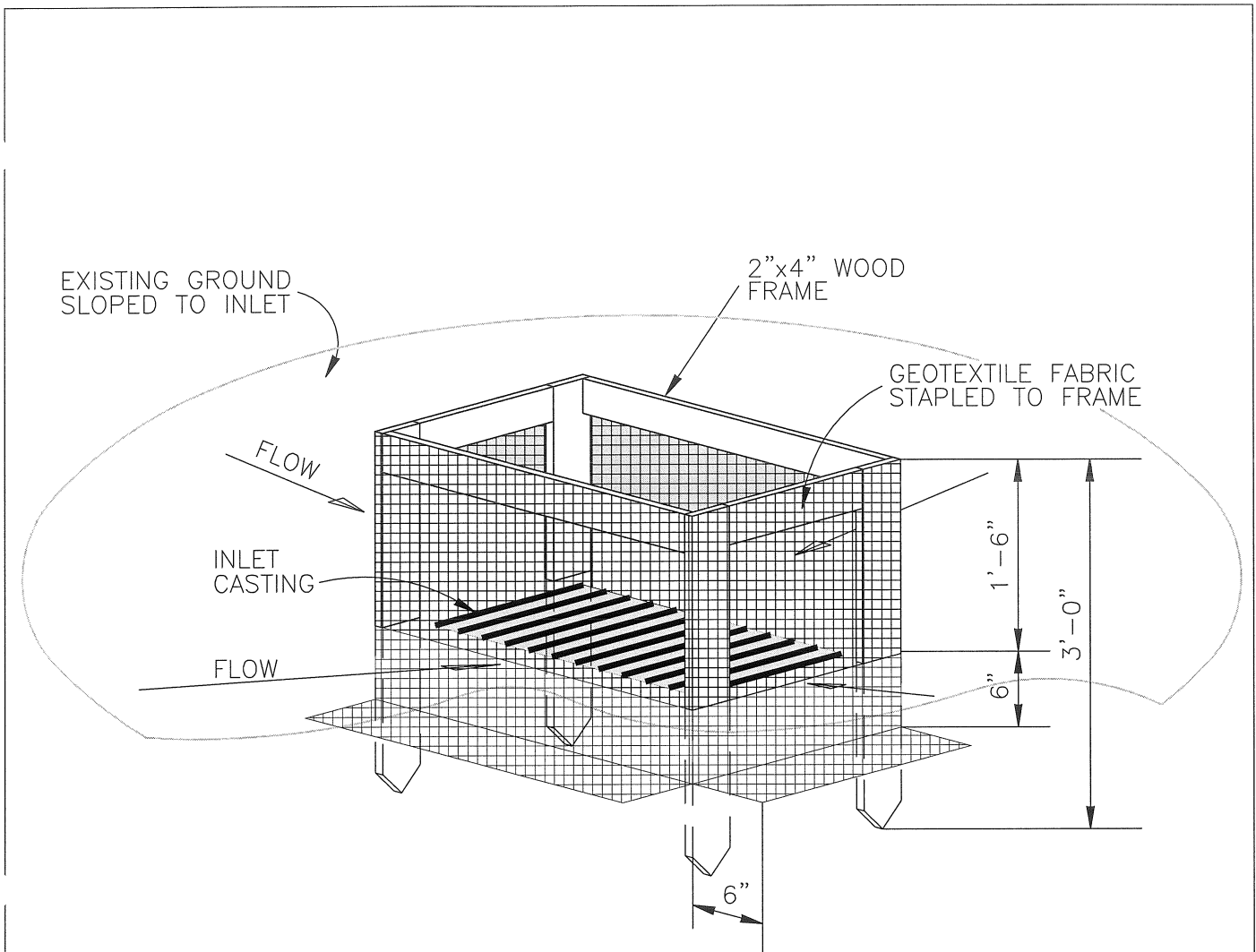

NOTES:

1. PREMANUFACTURED FRAMES MAY BE USED INSTEAD OF CONSTRUCTING WOOD FRAMES, PROVIDING THAT ADEQUATE SUPPORT FOR THE GEOTEXTILE FABRIC IS PROVIDED.
2. FABRIC SHALL BE INSTALLED IN ONE CONTINUOUS PIECE WRAPPED AROUND POSTS, OVERLAPPED ACROSS THE LAST GAP, ITS ENDS SECURELY SECURELY FASTENED TO SEPARATE POSTS.

SECTION NO. 3300	DRAWING NO. 6.2
REV.D. 2012	
<i>STORM SEWER INLET PROTECTION: TYPE A-2</i>	
CITY OF FARGO ENGINEERING DEPARTMENT	
APPROVED <i>BED</i>	DATE <i>2-21-2012</i>



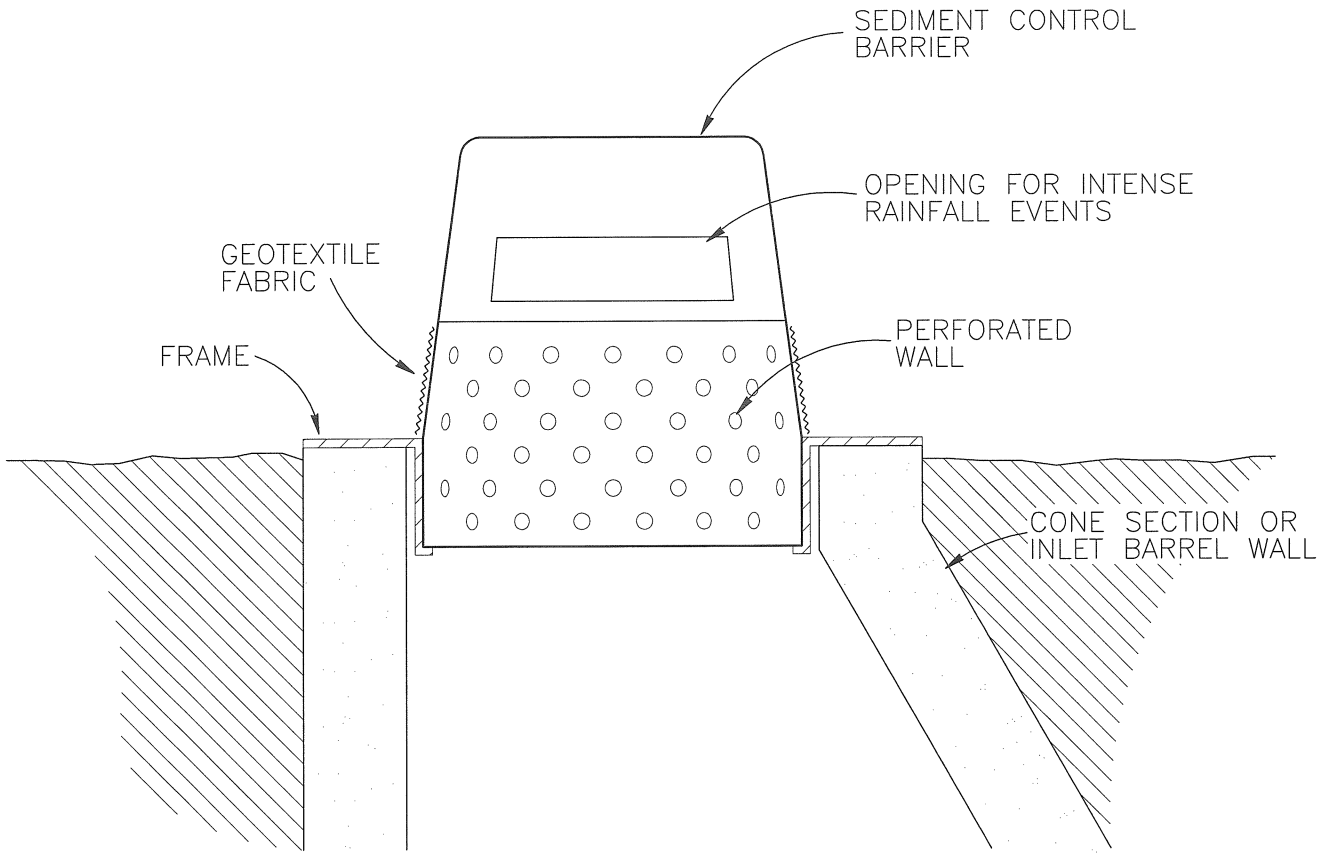

NOTE:

ALTERNATIVE INLET PROTECTION DEVICES MAY BE ALLOWED SUBJECT TO ENGINEERS APPROVAL.

WHEN REMOVING OR MAINTAINING INLET PROTECTION, CARE SHALL BE TAKEN TO INSURE THAT SEDIMENT TRAPPED ON THE GEOTEXTILE FABRIC DOES NOT FALL INTO INLET. ANY MATERIAL FALLING INTO INLET SHALL BE IMMEDIATELY REMOVED.

ANY INLET PROTECTION USED SHALL BE EQUIPPED WITH AN EMERGENCY OVERFLOW TO MINIMIZE THE THREAT OF STREET FLOODING DURING AN INTENSE RAINFALL EVENT.

SECTION NO. 3300	DRAWING NO. 6.3
REV.D. 2012	
<i>STORM SEWER INLET PROTECTION: TYPE B</i>	
CITY OF FARGO ENGINEERING DEPARTMENT	
APPROVED <i>BED</i>	DATE <i>2-21-2012</i>

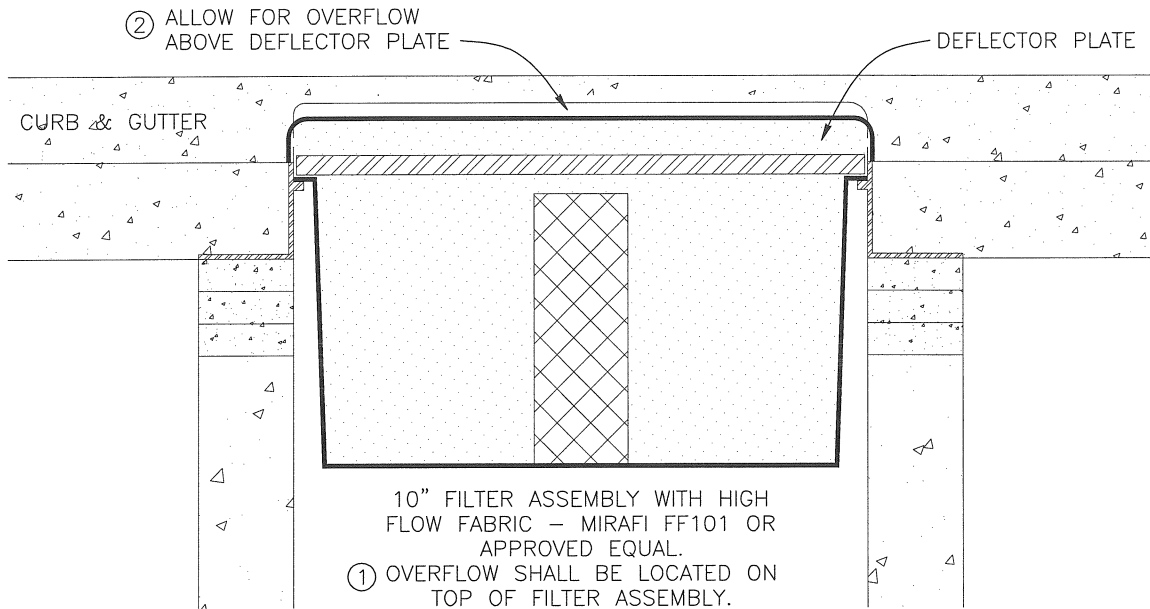

OVERFLOW ① – CENTER OF FILTER ASSEMBLY  
 OVERFLOW ② – TOP OF CURB BOX

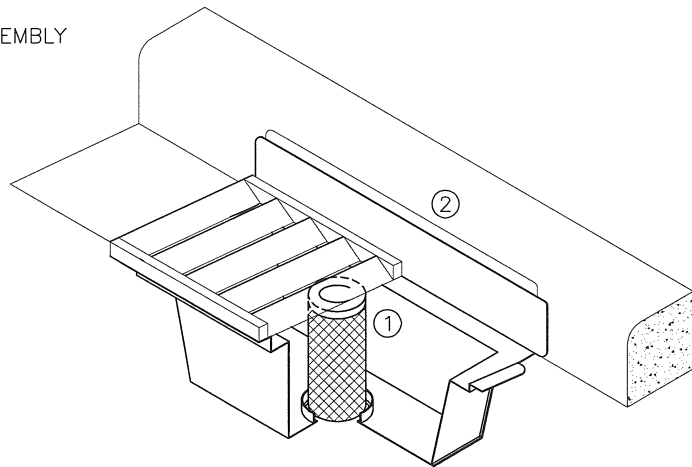

**INSTALLATION:**

- REMOVE THE INLET GRATE
- INSERT THE DEVICE INTO THE CASTING FRAME
- INSTALL GRATE INTO CASTING FRAME OVER TOP OF DEVICE

**MAINTENANCE:**

- CHECK REGULARLY & AFTER RAIN EVENTS. IF THE DEVICE IS FILLED WITH 1/3 OF ITS CAPACITY WITH SEDIMENT, EMPTY THE DEVICE.
- REMOVE DEBRIS AROUND THE INLET GRATE PRIOR TO REMOVING DEVICE

SECTION NO. 3300	DRAWING NO. 6.4
REV.D. 2012	
<i>STORM SEWER INLET PROTECTION: TYPE C</i>	
CITY OF FARGO ENGINEERING DEPARTMENT	
APPROVED <i>BFD</i>	DATE <i>2-21-2012</i>

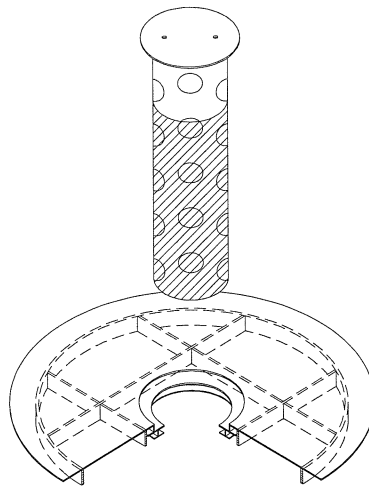
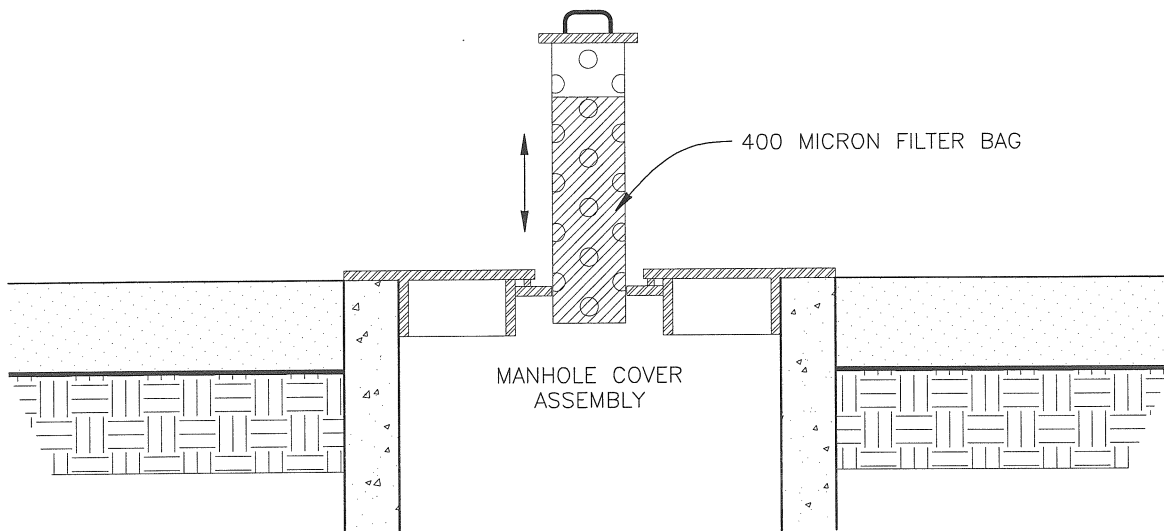

INSTALLATION:

- REMOVE THE INLET CASTING
- INSERT THE DEVICE INTO THE MANHOLE BARREL

MAINTENANCE:

- CHECK REGULARLY & AFTER RAIN EVENTS. IF THE FILTER IS PLUGGED REMOVE AND CLEAN THE FILTER.

SECTION NO. 3300	DRAWING NO. 6.5
REV,D. 2012	
<i>STORM SEWER INLET PROTECTION: TYPE C-2</i>	
CITY OF FARGO ENGINEERING DEPARTMENT	
APPROVED <i>BED</i>	DATE <i>2-21-2012</i>

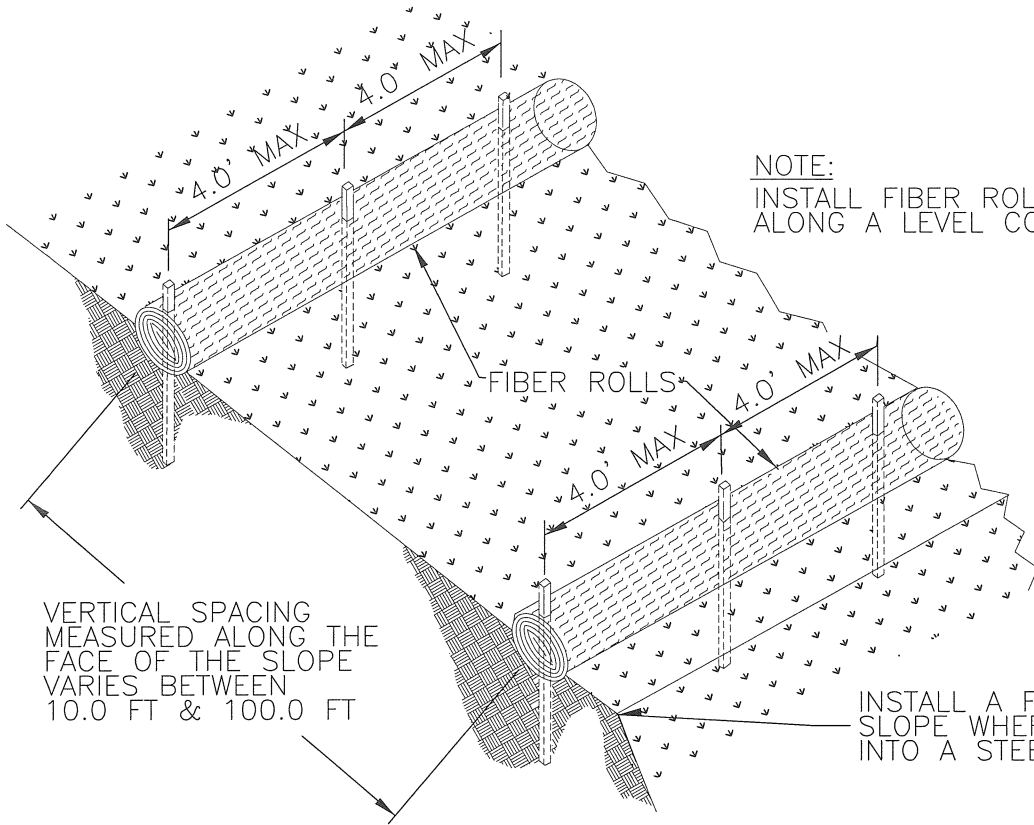

NOTE:  
INSTALL FIBER ROLL  
ALONG A LEVEL CONTOUR

VERTICAL SPACING  
MEASURED ALONG THE  
FACE OF THE SLOPE  
VARIES BETWEEN  
10.0 FT & 100.0 FT

INSTALL A FIBER ROLL NEAR  
SLOPE WHERE IT TRANSITIONS  
INTO A STEEPER SLOPE

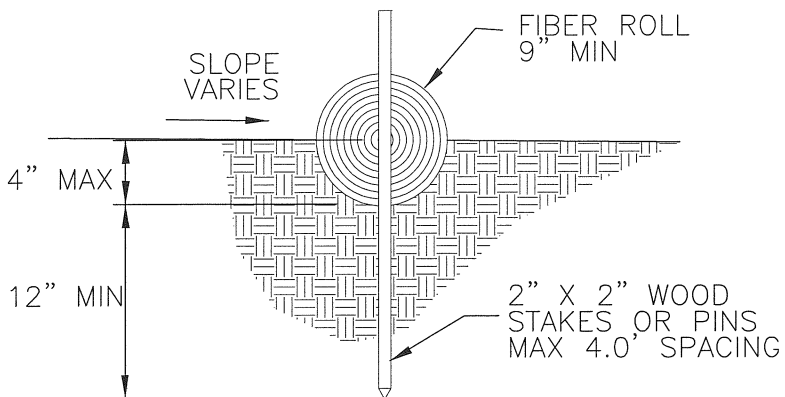
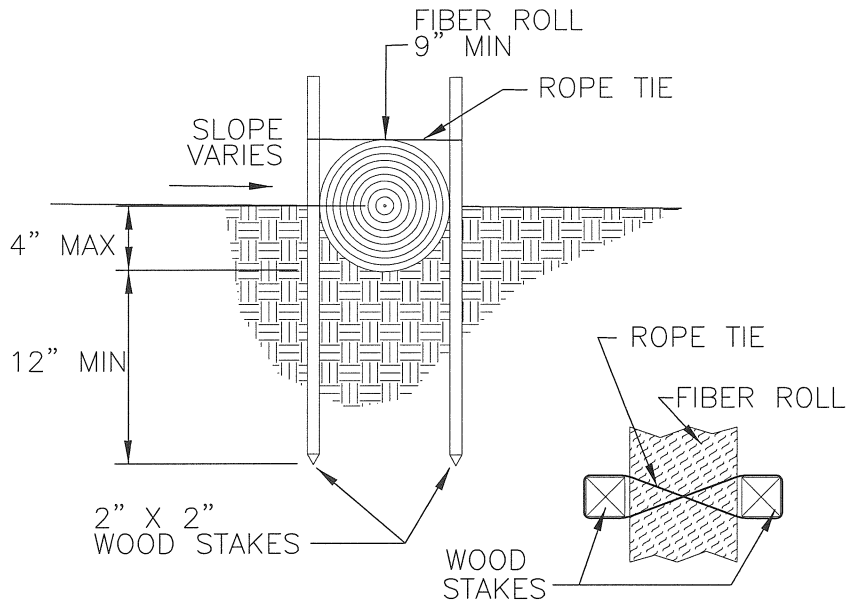

SECTION NO. 3300	DRAWING NO. 6.6
REV.D. 2012	
<i>FIBER ROLL INSTALLATION</i>	
CITY OF FARGO ENGINEERING DEPARTMENT	
APPROVED <i>BEED</i>	DATE <i>2-21-2012</i>

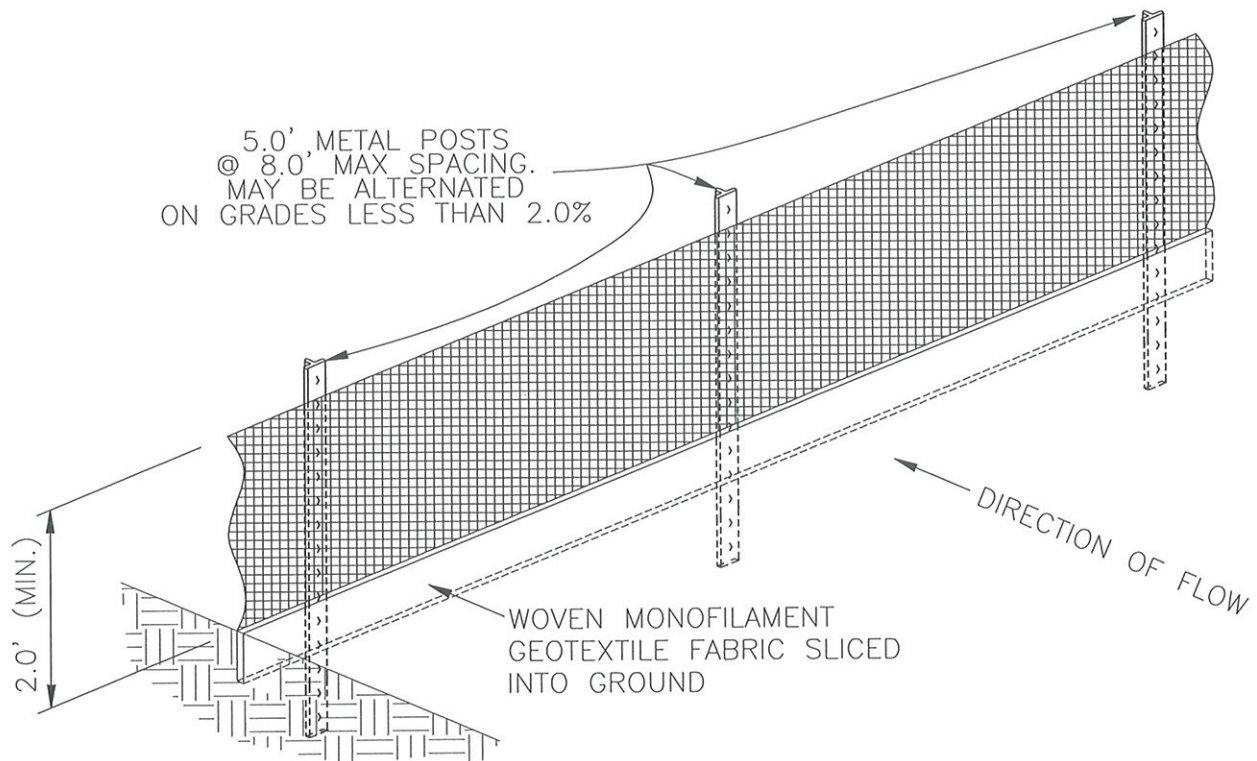

STANDARD

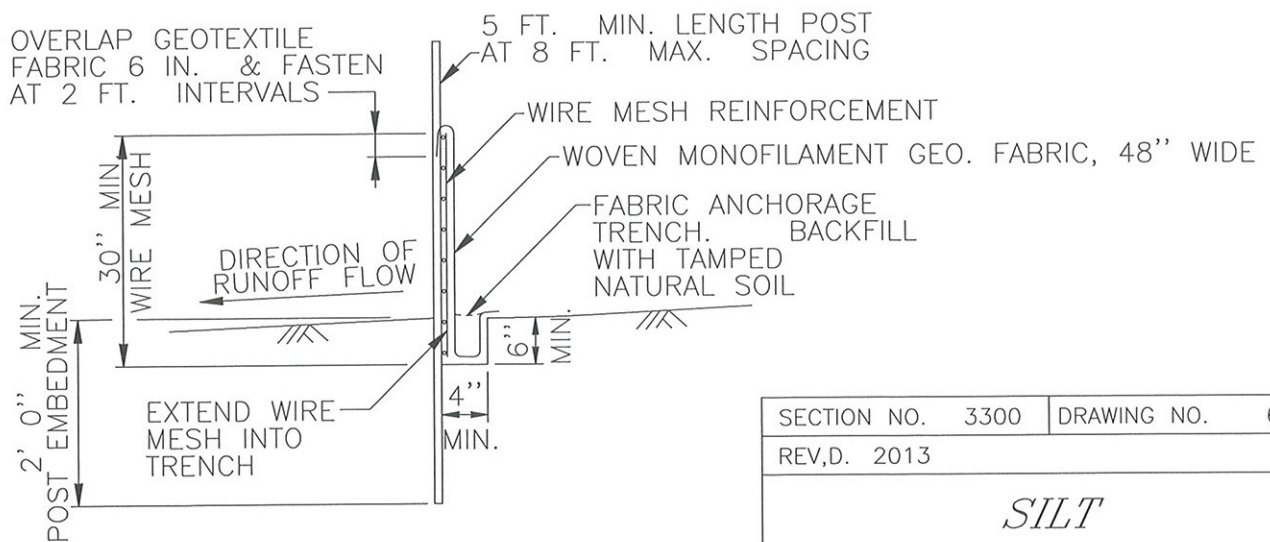

HEAVY DUTY

SECTION NO. 3300	DRAWING NO. 6.7
REV.D. 2013	
<i>SILT FENCE</i>	
CITY OF FARGO ENGINEERING DEPARTMENT	
APPROVED <i>CME</i>	DATE <i>1-2-13</i>

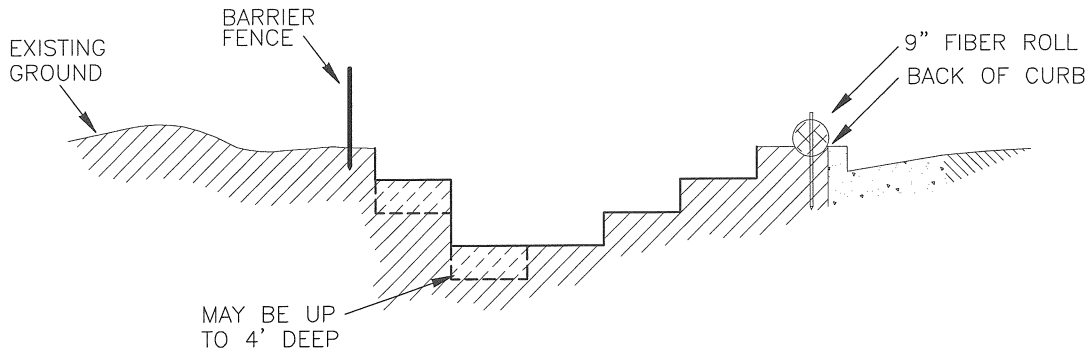

SECTION A-A

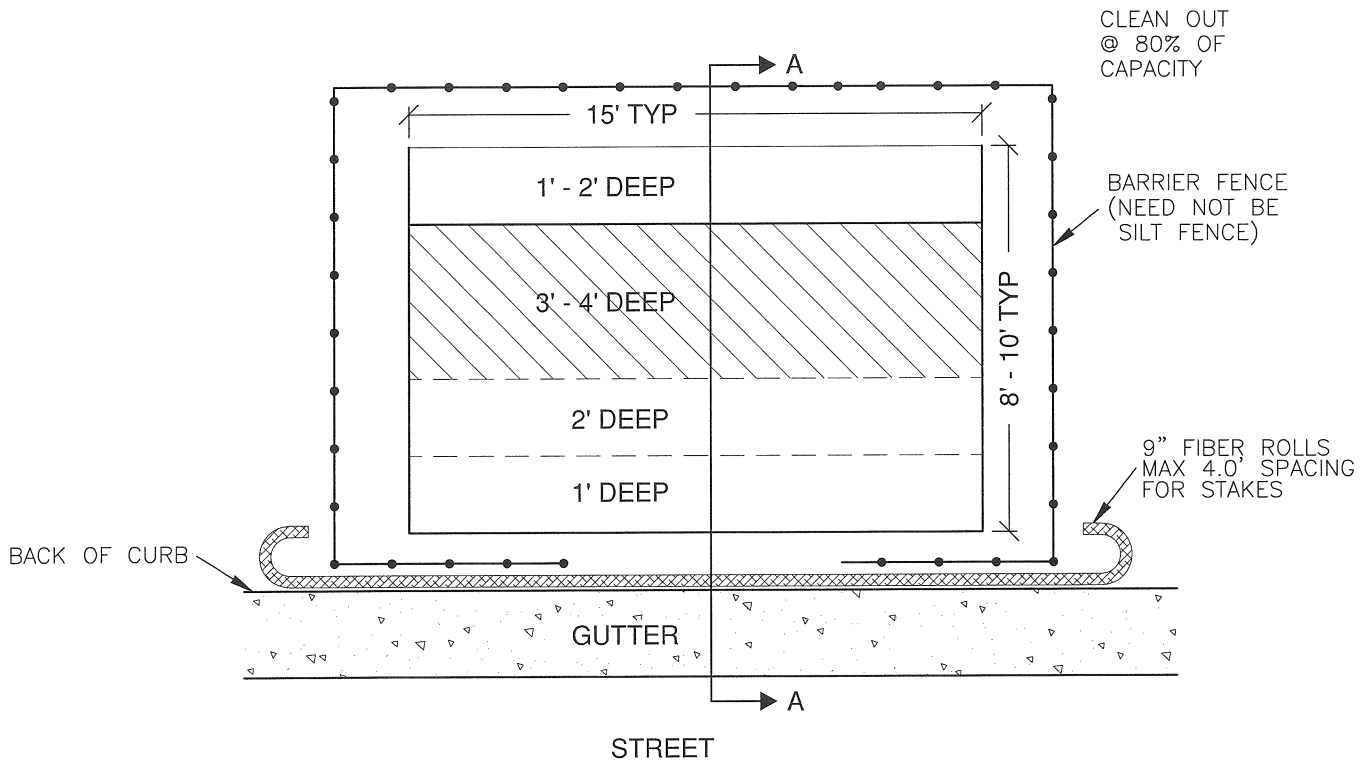

PLAN VIEW

SECTION NO. 3300	DRAWING NO. 6.8
REV,D. 2012	
<i>CONCRETE WASHOUT</i>	
CITY OF FARGO ENGINEERING DEPARTMENT	
APPROVED <i>BEO</i>	DATE <i>2-21-2012</i>

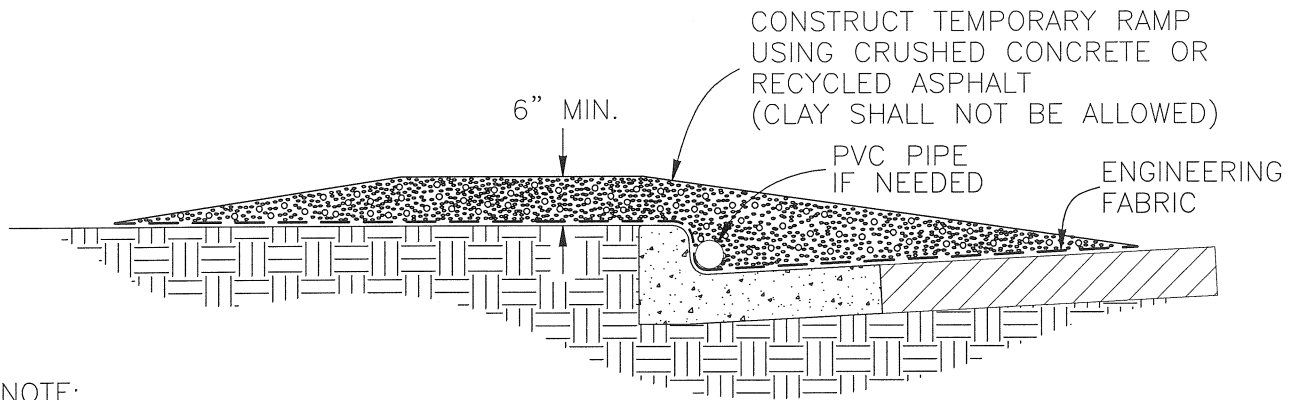

NOTE:

TEMPORARY ACCESS OVER EXISTING CURB & GUTTER SHOULD BE LOCATED AT HIGH POINTS IN THE STREET (IF POSSIBLE) TO MAINTAIN STREET DRAINAGE

TEMPORARY ACCESS OVER CURB & GUTTER

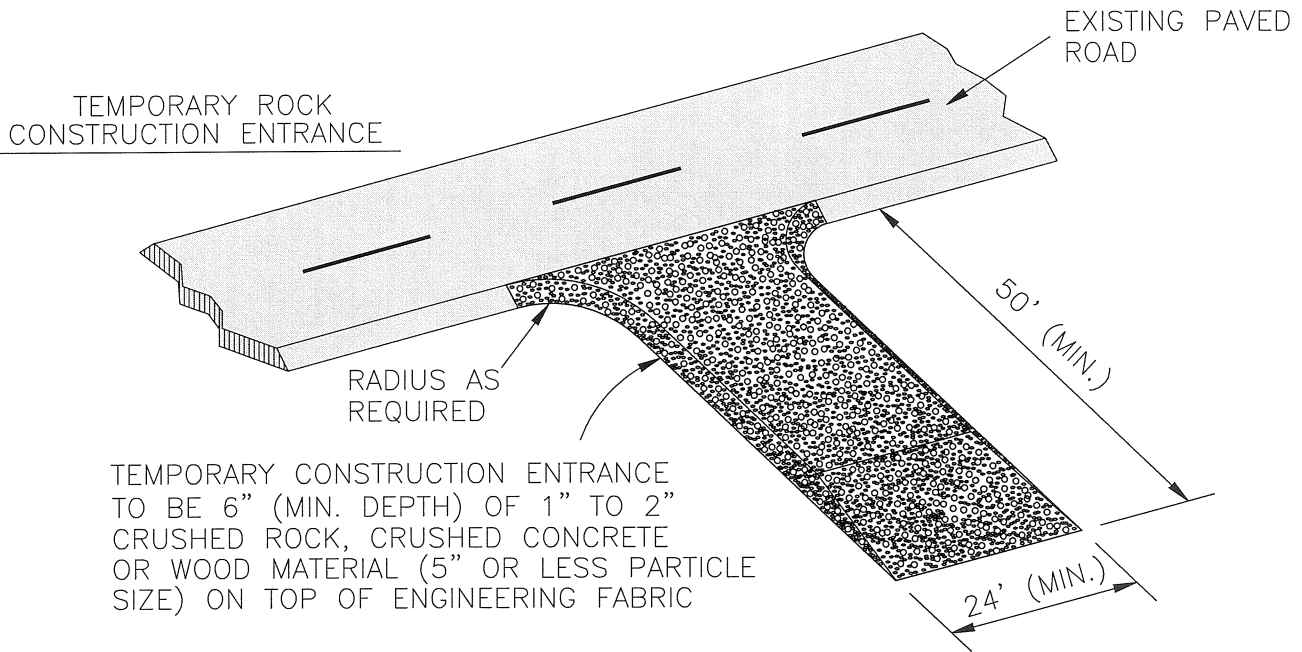

NOTES:

1. A TEMPORARY CONSTRUCTION ENTRANCE SHALL BE CONSTRUCTED AT ALL LOCATIONS WHERE CONSTRUCTION VEHICLES OR EQUIPMENT ENTER OR EXIT THE CONSTRUCTION SITES THAT ARE OVER 5 ACRES AND MAY BE REQUIRED BETWEEN 1 AND 5 ACRES AS DIRECTED BY THE ENGINEER.
2. UPON COMPLETION OF THE PROJECT, THE CONTRACTOR SHALL REMOVE THE TEMPORARY CONSTRUCTION ENTRANCE UNLESS NOTED OTHERWISE, AND THE SITE SHALL BE RESTORED TO IT'S PREVIOUS CONDITION.
3. ENTRANCES SHALL BE MAINTAINED IN A MANNER TO MINIMIZE THE TRACKING OF SEDIMENT ONTO PAVED SURFACES.
4. THE LOCATION OF TEMPORARY ENTRANCES SHALL BE AS SHOWN ON THE PLANS. IF NOT SHOWN ON THE PLANS, THE CONTRACTOR SHALL COORDINATE THE LOCATIONS WITH THE ENGINEER.
5. COSTS ASSOCIATED WITH CONSTRUCTION, MAINTENANCE AND REMOVAL OF TEMPORARY ENTRANCES SHALL BE INCLUDED IN THE BID ITEM "TEMPORARY CONSTRUCTION ENTRANCE"

SECTION NO. 3300	DRAWING NO. 6.9
REV.D. 2012	
<i>TEMP. CONSTRUCTION ENTRANCE</i>	
CITY OF FARGO ENGINEERING DEPARTMENT	
APPROVED <i>BED</i>	DATE <i>2-21-2012</i>

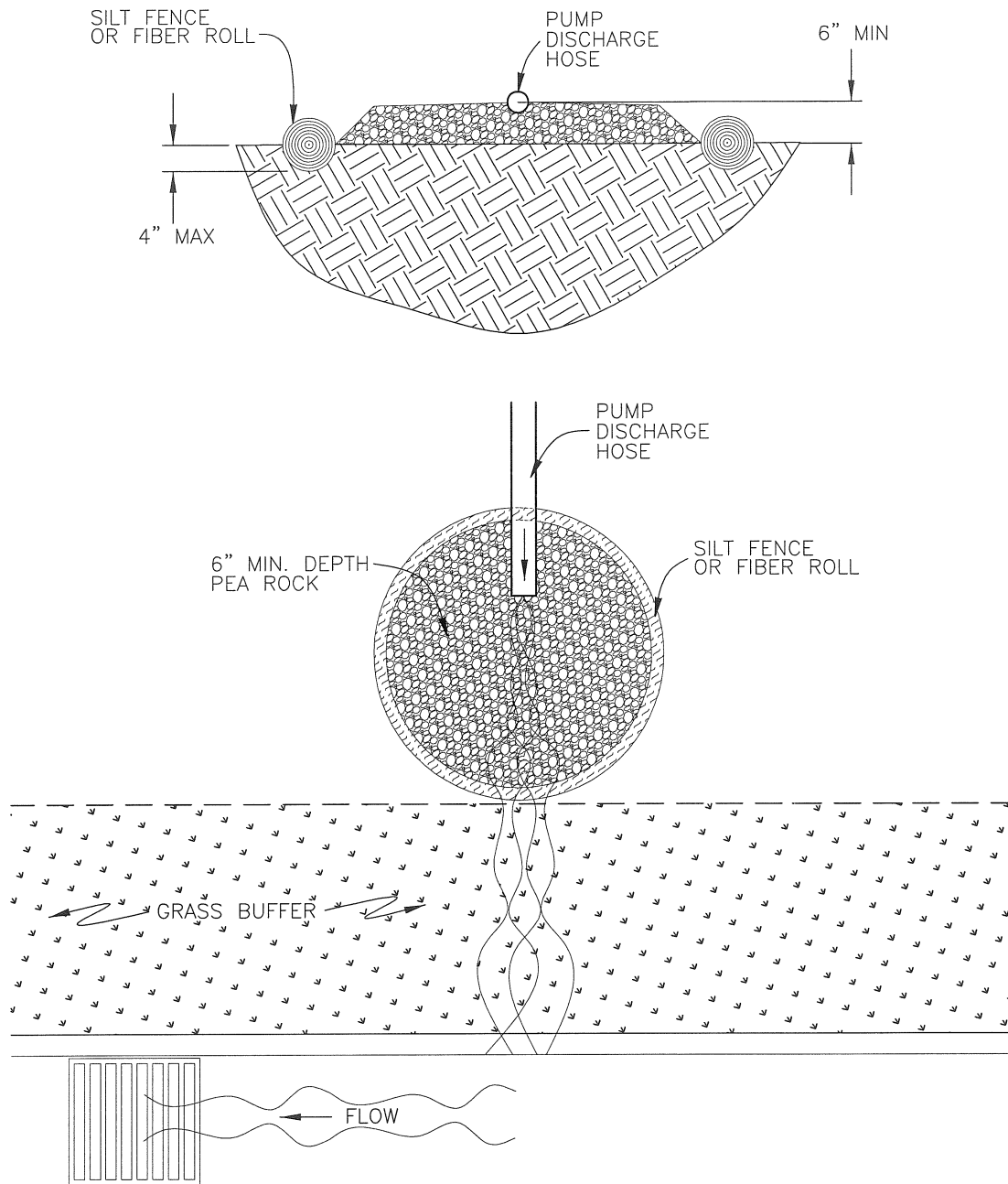

**NOTES:**

1. DISCHARGE WATER ONTO A GRASS LINE SWALE, GRASS FIELD, OR INTO A SECONDARY SEDIMENT CONTAINMENT SYSTEM.
2. DISCHARGE WATER MUST FLOW AWAY FROM THE CONSTRUCTION AREA.
3. THE PEA ROCK MAY BE PLACED ON GRASS OR ENGINEERING FABRIC MAY BE USED: DEWATERING STRUCTURE SHALL NOT BE PLACED ON BARE SOIL.
4. THE CAPACITY OF THE STRUCTURE SHALL BE ADEQUATE TO HANDLE THE DEWATERING PUMP DISCHARGE.

SECTION NO. 3300	DRAWING NO. 6.10
REV.D. 2012	
<i>DEWATERING STRUCTURE OPTION #1</i>	
CITY OF FARGO ENGINEERING DEPARTMENT	
APPROVED <i>BED</i>	DATE <i>2-21-2012</i>



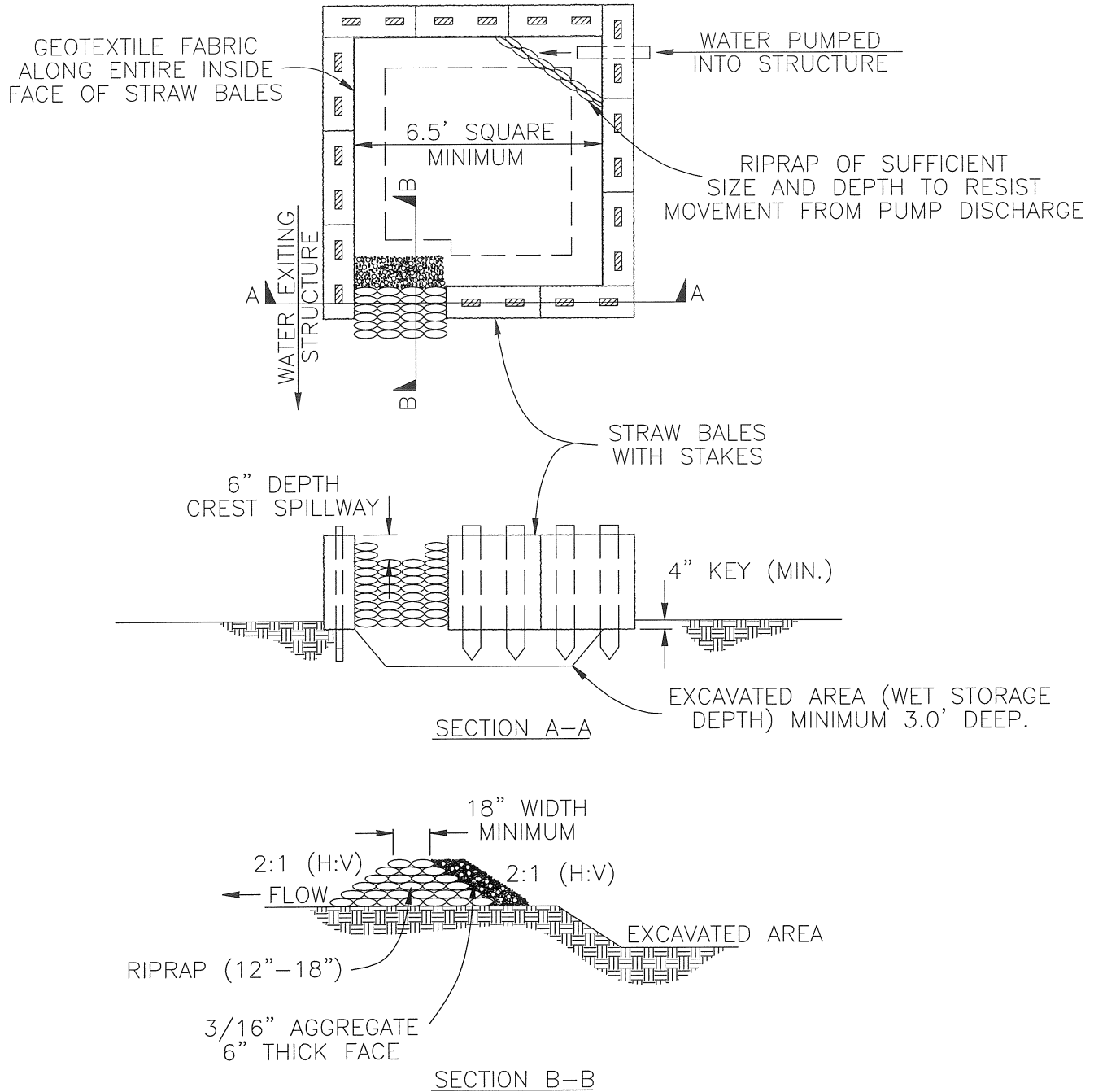

**NOTES:**

1. STORAGE VOLUME OF PIT : PUMP DISCHARGE X 16 = CUBIC FEET OF STORAGE REQUIRED. IN CALCULATING THE CAPACITY, INCLUDE THE VOLUME AVAILABLE FROM THE FLOOR OF THE EXCAVATION TO THE CREST OF THE STONE WEIR.
2. ONCE THE WATER LEVEL NEARS THE CREST OF THE STONE WEIR (EMERGENCY OVERFLOW), THE PUMP MUST BE SHUT OFF WHILE THE STRUCTURE DRAINS DOWN TO THE ELEVATION OF THE EXCAVATED AREA. THE REMAINING WATER MAY BE REMOVED ONLY AFTER A MINIMUM OF 6 HOURS OF SEDIMENT SETTLING TIME. THIS EFFLUENT SHOULD BE PUMPED ACROSS AN AREA WITH ESTABLISHED VEGETATION OR THROUGH A SILT FENCE PRIOR TO ENTERING A STORM SEWER SYSTEM. WHEN THE EXCAVATED AREA BECOMES FILLED TO 1/2 OF THE EXCAVATED DEPTH, ACCUMULATED SEDIMENT SHOULD BE REMOVED AND PROPERLY DISPOSED OF.

SECTION NO. 3300	DRAWING NO. 6.11
REV.D. 2012	
<i>DEWATERING STRUCTURE OPTION #2</i>	
CITY OF FARGO ENGINEERING DEPARTMENT	
APPROVED <i>BED</i>	DATE <i>2-21-2012</i>

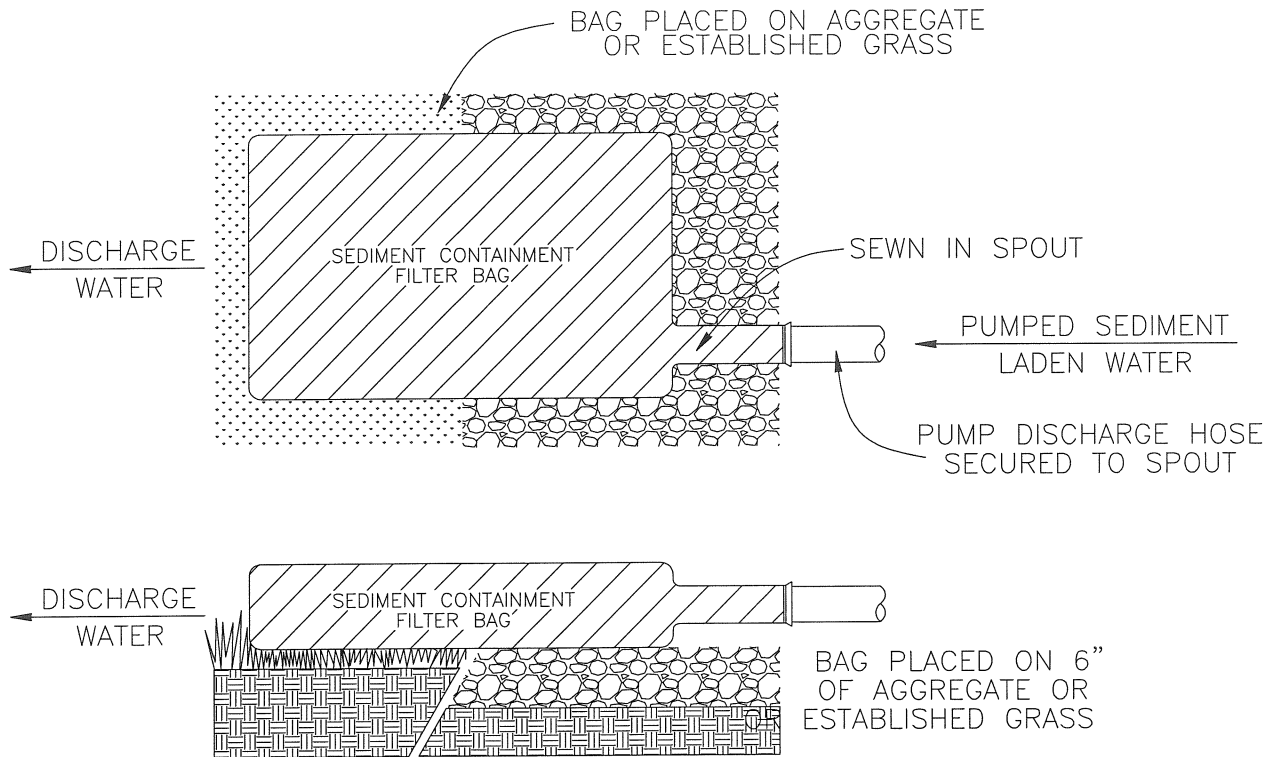

SEDIMENT FILTER BAG

NOTES:

1. DISCHARGE WATER ONTO A GRASS LINE SWALE, GRASS FIELD, OR INTO A SECONDARY SEDIMENT CONTAINMENT SYSTEM.
2. DISCHARGE WATER MUST FLOW AWAY FROM THE CONSTRUCTION AREA.
3. SEDIMENT CAPTURED BY THE FILTER BAG MUST BE REMOVED AND STABILIZED.
4. THE FILTER BAG SHOULD BE CONSTRUCTED OF NON-WOVEN GEOTEXTILE MATERIAL THAT WILL PROVIDE ADEQUATE FILTERING ABILITY TO CAPTURE THE LARGER SOIL PARTICLES FROM THE PUMPED WATER.
5. THE BAG MAY BE PLACED ON WELL ESTABLISHED GRASS OR 6" MINIMUM OF AGGREGATE. FILTER BAG SHALL NOT BE PLACED ON BARE SOIL.
6. THE CAPACITY OF THE FILTER BAG SHALL BE ADEQUATE TO HANDLE THE DEWATERING PUMP DISCHARGE, AND SHOULD BE BASED ON THE BAG MFG.'S RECOMMENDATION.
7. WHEN USED IN CONJUNCTION WITH A STRAW BALE/SILT FENCE PIT, A FILTER BAG MAY BE OPERATED UNTIL THE WATER IN THE PIT REACHES THE CREST OF THE EMERGENCY OVERFLOW. THE PUMP MUST BE SHUT OFF AT THIS POINT.
8. REMOVE SEDIMENT FROM FILTER BAG, REGRADE IN PLACE, AND IMMEDIATELY STABILIZE.

SECTION NO. 3300	DRAWING NO. 6.12
REV.D. 2012	
<i>DEWATERING STRUCTURE OPTION #3</i>	
CITY OF FARGO ENGINEERING DEPARTMENT	
APPROVED <i>BED</i>	DATE <i>2-21-2012</i>

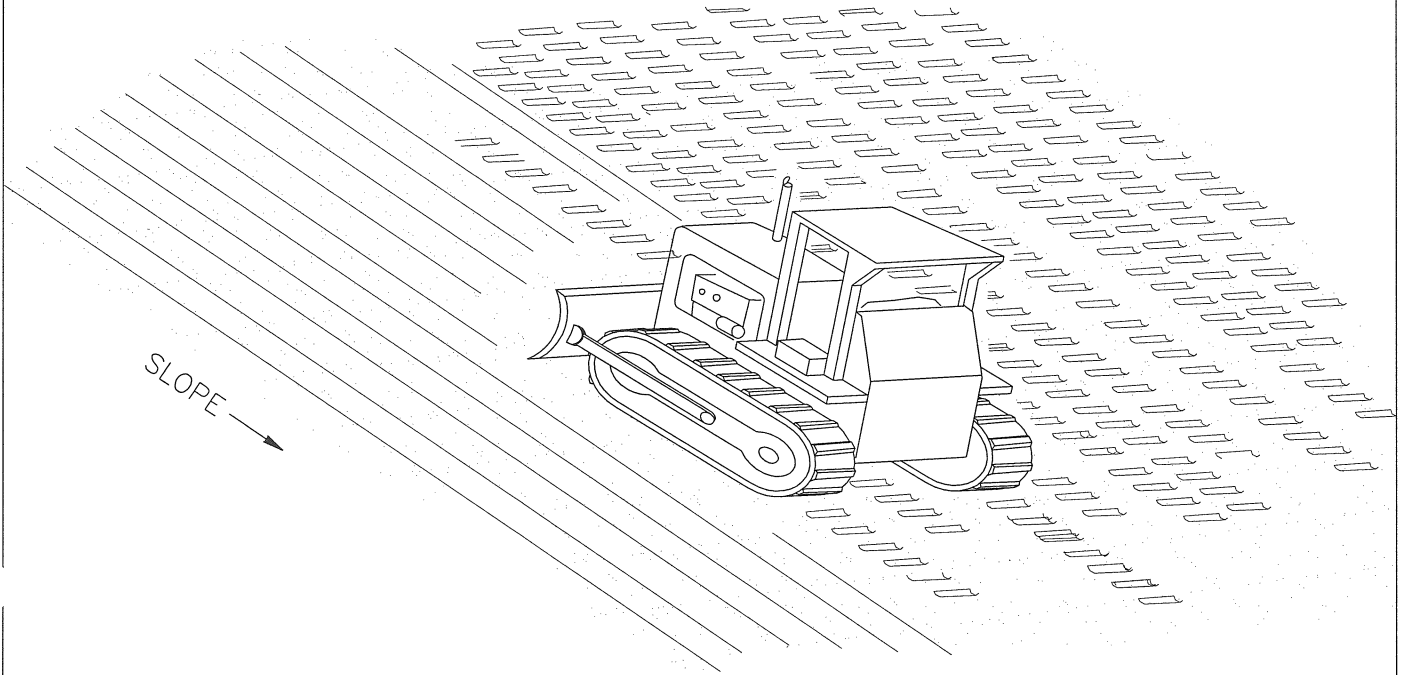

NOTE

'TRACKING' WITH MACHINERY UP AND DOWN THE SLOPE PROVIDES GROOVES THAT WILL CATCH SEED, FERTILIZER, MULCH, RAINFALL AND REDUCE RUNOFF.

ALL DISTURBED SLOPES TO BE TRACKED AS SHOWN BETWEEN TIME OF EMBANKMENT AND SEEDING.

SECTION NO. 3300	DRAWING NO. 6.13
REV,D. 2012	
<i>SURFACE ROUGHENING</i>	
CITY OF FARGO ENGINEERING DEPARTMENT	
APPROVED <i>BEO</i>	DATE <i>2-21-2012</i>

**CITY OF FARGO SPECIFICATIONS  
BUILDING DEMOLITION**

**PART 1  
DESCRIPTION OF WORK**

The work to be done under these Specifications shall include all labor, materials, equipment and services necessary to complete all demolition work as shown on the accompanying plans, or as specified herein, or both.

**PART 2  
MATERIAL**

THIS SECTION IS NOT USED.

**PART 3**  
**CONSTRUCTION**

*3.1. DEMOLITION OF STRUCTURES - ORDERED BY THE INSPECTIONS DEPARTMENT*

*3.1.1. PROTECTION OF EXISTING FACILITIES*

The Contractor shall, as soon as he receives a Notice to Proceed with the work, enter the premises and do any and all things necessary to protect the premises from damage by unauthorized persons.

The Contractor shall protect all existing equipment, pavements, tracks, poles, pipes, utilities, etc., which are not affected by demolition work. All roofs and walls affected by demolition work shall be kept weather-tight. The Contractor shall provide all shoring, bracing, tarps, temporary partitions, barricades, and/or other safety devices deemed necessary by the Engineer for the protection of existing facilities.

*3.1.2. OWNERSHIP OF PROPERTY*

No right, title property or interest of any kind whatsoever in or to the land or premises upon which such buildings or structures stand, is created, assigned, conveyed, granted, or transferred to the Contractor, or any other person or persons, except only the license and right of entry to remove such buildings and structures in strict accordance with the Contract.

*3.1.3. RODENT EXTERMINATION*

After the Contractor has been awarded the bid and prior to commencing demolition work, the City of Fargo Health Department shall be contacted and proper action shall be taken, if necessary, for rodent extermination. If the Health Department determines that a rodent problem exists, the Contractor shall hire an approved exterminator for removal of the rodent problem, the costs of which shall be handled as an extra to the contract with the costs being assessed against the property.

### 3.1.4. DEMOLITION REQUIREMENTS

The work under this contract shall consist of the following:

- A. Demolition and removal of all dangerous structures on the site. Burying foreign materials in the excavation will not be allowed. Burning materials will not be allowed.
- B. Removal of all exterior foundation walls to a level six (6) feet below the adjoining ground. On residential lots, the entire foundation shall be removed.
- C. Removal of all other walls, partition walls, columns, piers, beams, or other projections, basement floors, and all footings to a level three (3) feet below the adjoining ground. The existing floor slabs shall be rubblized.
- D. Utility lines.
  - 1) Seal storm and/or sanitary sewer lines leading from buildings being demolished at the foundation wall.
  - 1a) When buildings are demolished on lots that are adjacent to rivers, drains, or wetlands, additional measures shall be taken to seal the sanitary sewer. A bid item for "Sewer Service Closure" shall consist of excavating to the existing sewer service at the property line & installing a PVC cap on the street side of that sewer. A PVC cap installed on a PVC sewer service shall be bonded together using PVC Primer and PVC Cement to solvent weld the PVC cap to the abandoned sewer service line. Cement plugs will not be allowed for sewer service closures.

If the sewer service line material is not PVC, the Contractor shall use a banded Fernco fitting with a solid PVC termination cap. The final product shall be a watertight termination of the sewer service line. The entire length of sewer service shall be removed from the structure to the boulevard, followed by backfilling with the excavated material. All underground utility excavations not located under City streets shall be backfilled with the same material that is excavated from the trench

(clay backfill, unless noted otherwise) compacted to 90% standard proctor density. All material and labor costs necessary shall be included in the appropriate bid items for service closures. In the event that porous material is excavated (sand/gravel), clay backfill shall be imported and placed in the excavation.

For any utility excavation located within a City street, the Contractor will be required to meet the requirements of the City of Fargo excavation permit.

**City of Fargo personnel must be present during all service terminations. If services are terminated without City inspection, the Contractor shall uncover the services for inspection at no additional cost to the City of Fargo.**

- 2) The City of Fargo Water Department, at no cost to the Contractor, will shut off water at the curb box and remove water meters from the buildings upon receipt of notification from the Contractor that the building or buildings have been vacated.
- 3) The cost of shutting off the corporation valves and/or gate valves at the water main will be borne by the Contractor and shall be to the satisfaction of the City of Fargo Water Department procedures & methods with written approval by them.

Water services shall be turned off at the corporation & the service line shall be cut 1.0' from the corporation. A compression fitting shall be flared at the end of the 1.0' stub and a copper penny inserted in the end to complete the water service termination.

- 4) Gas services shall be turned off at existing valves by and under the supervision of the utility company owning the service. Notification of termination of gas service shall be made by the Contractor to the appropriate division of Xcel Energy. Gas will be shut off at the gas main in the street and all gas meters will be removed by the utility company at no cost to the Contractor.



- 5) Disconnect electric wires as per rules and regulations of authorities having jurisdiction. Notification of termination of electric service shall be made by the Contractor to Xcel Energy or Cass County Electric. The respective power company will remove meters, poles, overhead wires, and transformers at no cost to the Contractor.
  - 6) Disconnect telephone wires as per rules and regulations of authorities having jurisdiction. Notification of termination of telephone service shall be made by the Contractor to the appropriate serving utility. The telephone company will remove poles and overhead wires, at no cost to the Contractor. Any equipment or wires left by the Telephone Company within the building will be intentional on their part and will be up to the Contractor to remove.
  - 7) Disconnect cable television wires as per rules and regulations of authorities having jurisdiction. Notification of termination of cable television service shall be made by the Contractor to the appropriate serving utility.
  - 8) The Contractor shall arrange removal of any other wires.
  - 9) Maintain and preserve utilities traversing premises as long as same are required.
- E. Removal from the basement of all piping, boilers, or other fixtures, and all wood, furniture, rubbish, or other debris. Fuel oil tanks shall be properly disposed of by the Contractor and the cost shall be included in the lump sum demolition price.
- F. Removal of all concrete basement floors or breaking up of all concrete floors in no larger than three (3) foot squares so that water cannot collect.
- G. Remove all foundation walls, partition walls, footings, columns, piers, beams, or other projections from basements, cellars, right-of-way encroachments, and other excavations with the exception of exterior walls that lie on the boundaries formed by the adjoining streets and alleys.

- H. All basements indicated shall be filled. Where excavations or open basements are not backfilled within 24 hours, the Contractor will be required to encircle the open area by a standard snow fence, or equal type of fencing, for safety reasons.
- I. Performance of all other incidental work necessary to fully complete the contract.
- J. Walls over ten feet high of any width or length shall not remain standing after working hours unless adequate lateral support is provided.
- K. Upon completion of demolition, sufficient filling and grading shall be done to bring the area up to a level as specified in the contract proposal. The backfill will be of clay soil, compacted to a density of 90% unless otherwise specified. The Contractor will have an independent testing agency test the backfill. A minimum of two passing tests at various depths will be taken and furnished to the City. The cost of testing will be incidental to the cost of the project.
- L. All rubbish, non-reusable fill, debris, equipment, etc., resulting from demolition work shall be removed from the premises during and/or upon the completion of work, leaving the site area acceptable to the satisfaction of the Engineer.
- M. Site restoration shall consist of fine grading the site to ensure positive drainage and conform to the surrounding sites.
- N. The Contractor shall furnish the disposal site for all demolition materials, non-reusable fill & rubbish. If the Contractor chooses to dispose the material in the City of Fargo Landfill the Contractor will be responsible for all tipping fees.
- O. The Contractor shall take whatever steps necessary to control dust during demolition and removal. **Water shall be sprayed to adequately wet the debris to control dust during the entire demolition process.** The Contractor shall provide the watering equipment or obtain a water meter from the City of Fargo to connect to a fire hydrant to satisfy this requirement. The watering requirement will be waived if temperatures are below freezing.

All trucks hauling demolition debris shall be tarped so construction debris is contained from the demolition site to the disposal site. The Contractor shall

monitor & collect any debris on the haul road associated with the demolition project.

- P. Thermostats containing mercury must be disposed of into landfills, contingent upon acceptance by the landfill authority. Disposal is enhanced by covering the mercury containing device with soil before breaking the mercury container. This helps to bind the mercury with the soil rather than it being released to the atmosphere where the vapor poses a health concern. Any cost associated with the disposal of a thermostat containing mercury shall be included in the demolition bid item.

Q. Permits & Notifications

The Contractor shall provide an anticipated construction schedule. If the construction schedule changes the Contractor shall be required to supply a revised schedule.

The Contractor shall also be required to notify adjoining property owners 48 hours in advance of any parking restrictions/street closings affecting access to their property. This can be accomplished by posting temporary laminated signs in the vicinity of the closure/work zone.

The Contractor shall be responsible for obtaining all permits necessary for demolition of each structure. Permits costs shall be included in the Demolition bid item. Permits shall include but are not limited to:

- Obtaining a demolition permit from the City of Fargo Inspections Department.
- Obtaining all permits from the City of Fargo Engineering Department to transport equipment into and out of each site.
- Completing & submitting an Erosion & Sediment Control Permit from the City of Fargo Engineering Department.

- Completing & submitting an Asbestos Notification of Demolition and Renovation to the NDDOH; Must be submitted **10 working days** prior to the demolition of the structure(s).

Submitting a Lead-Based Paint Notification of Abatement and Demolition Clearance to the NDDOH; Must be submitted **10 working days** prior to the demolition of the structure(s). When submitting this form check yes in box III under the assumption that the structure has lead paint. Fill in all other areas of the form that apply.

R. Asbestos Testing

Asbestos Notification of Demolition and Renovation forms must be completed by the Contractor **and submitted** to the North Dakota Department of Health.

If necessary the cost of testing, abating & monitoring required during demolition activities for compliance shall be included in the bid item for demolition.

All abatement activities must be conducted in accordance with requirements set forth by the North Dakota Department of Health and the EPA's NESHAP Regulation. The City of Fargo shall not be held responsible if the Contractor fails to abide & comply with the guidelines as stated above.

S. Demolition of Structures with Asbestos:

**Regulated asbestos containing materials must be abated prior to commencing demolition activities.** Non-regulated category 1 non-friable asbestos may remain in place during demolition activities if the criteria listed in the Demolition Survey recommendations are adhered to.

The Contractor shall assign the removal of regulated asbestos containing materials to an asbestos removal Contractor licensed with the State of North Dakota. The Contractor shall submit to the City of Fargo documentation certifying that regulated asbestos was removed from the properties and shall follow all rules and regulations regarding asbestos removal. The City of Fargo shall not be held liable for actions or damages caused by the Contractor or his subcontractors if asbestos is not properly removed & disposed during demolition activities.

The Contractor shall notify the City of Fargo landfill when asbestos containing materials will be transported and disposed of at the landfill. The Contractor shall submit a waste manifest form to the landfill when disposing waste containing asbestos. The cost for all landfill tipping fees & subcontracting asbestos abatement shall be included in the bid item for demolition.

T. Lead Based Paint

The City of Fargo will not be requiring the Contractor to perform abatement of lead-based paint in any of the structures to be demolished or moved. After the structure & debris have been removed & the site is backfilled, the City will require that a risk assessor perform a visual inspection for any paint chips. Any paint chips found shall be removed from the site by the Contractor & disposed according to all applicable rules & regulations for lead paint disposal.

U. Miscellaneous Solid Waste (MSW)

The previous homeowners were required to remove all belongings from the property. However, some materials may have been left behind and will need to be removed by the Contractor during the demolition process. Disposal of all Miscellaneous Solid Waste (MSW) shall be incidental to the price bid for demolition. This shall also include any items that would need to be properly disposed at a hazardous waste facility.

The Contractor may deposit all hazardous waste material to the City of Fargo Household Hazardous Waste (HHW) at no charge during business hours. The HHW building is located at #606 43 1/2 Street North.

3.2. DEMOLITION OF FLOOD ACQUISITIONS - ORDERED BY THE ENGINEERING DEPARTMENT

*3.2.1. PROTECTION OF EXISTING FACILITIES*

Upon taking possession of each residence, the city has secured the structure by covering exterior doors and windows with plywood or OSB. The Contractor shall, as soon as he receives a Notice to Proceed with the work, enter the premises and do any and all things necessary to protect the premises from damage by unauthorized persons. Maintaining

plywood over doors and windows shall be performed until demolition of the structure occurs.

The Contractor shall protect all existing equipment, pavements, tracks, poles, pipes, utilities, etc., which are not affected by demolition work.

Prior to demolition the Contractor shall be responsible for removing and salvaging the plywood or OSB from each structure and deliver them to the City of Fargo Public Safety Building at 4630 15th Avenue North. Not a separate pay item, cost to be included in other items. Plywood or OSB that is intentionally damaged by the Contractor during removal will be deducted from the contract at a price noted in the Special Instructions to Bidders or \$0.25/SF if not specifically noted.

### *3.2.2. OWNERSHIP OF PROPERTY*

No right, title property or interest of any kind whatsoever in or to the land or premises upon which such buildings or structures stand, is created, assigned, conveyed, granted, or transferred to the Contractor, or any other person or persons, except only the license and right of entry to remove such buildings and structures in strict accordance with the Contract.

Only such property may be salvaged by the Contractor as is owned by the City of Fargo, and in the event of any doubt respecting the ownership of any particular property, the Contractor shall request from the City of Fargo a written statement respecting its ownership.

All salvage becomes the property of the Contractor, but storage of such materials and equipment in the project area will not be permitted except for the duration of the contract.

### *3.2.3. RODENT EXTERMINATION*

After the Contractor has been awarded the bid and prior to commencing demolition work, the City of Fargo Health Department shall be contacted and proper action shall be taken, if necessary, for rodent extermination. If the Health Department determines that a rodent problem exists, the Contractor shall hire an approved exterminator for removal of the rodent problem, the costs of which shall be handled as an extra to the contract with the costs being assessed against the property.

### 3.2.4. DEMOLITION REQUIREMENTS

The work under this contract shall consist of the following:

- A. Demolition and removal of all structures on the site. Burying foreign materials in the excavation will not be allowed. Burning materials will not be allowed.
- B. **Full depth removal** of foundation walls, partition walls, columns, piers, beams, or other projections, basement floors, garage slabs, concrete entry stoops, floodwalls, retaining walls, drain tile, all footings and all porous fill material is required. Contractor shall visit each site to determine the existence of floodwalls or retaining walls that shall be included in the demolition bid item. Buried objects not shown on the plans shall be removed.
- C. Sewer and Water Service Closures

The City of Fargo Water Department, at no cost to the Contractor, will shut off water at the curb box and remove water meters from the buildings.

The cost of shutting off the corporation valves and/or gate valves at the water main will be borne by the Contractor and shall be to the satisfaction of the City of Fargo Water Department procedures & methods with written approval by them.

In the event that the Contractor must perform an emergency shutdown of the water main during the water corporation closure, the foreman shall appoint a representative of the Contractor to personally notify all affected residences of the shutdown & the anticipated length of interrupted service. If the length of shutdown is greater than 8 hours the Contractor shall provide temporary water to the affected residents.

Water services shall be turned off at the corporation & the service line shall be cut 1.0' from the corporation. A compression fitting shall be flared at the end of the 1.0' stub and a copper penny inserted in the end to complete the water service termination.

Sewer service closures shall be made as close as practical to the sewer main in the street. A PVC cap shall be installed on a PVC sewer service by using PVC Primer and PVC Cement to solvent weld the PVC cap to the abandoned sewer service line. Cement plugs will not be allowed for sewer service closures.

In the event that the service line material is not PVC, the Contractor shall use a banded Fernco fitting with a solid PVC termination cap. The final product shall be a watertight termination of the sewer service line.

The entire length of sewer & water lines shall be removed from the house to the termination points. Field locations of services may be necessary if tie information is not available or is inaccurate. All gravel bedding/pipe encasement for service lines shall be excavated & disposed.

**City of Fargo personnel must be present during all service terminations. If services are terminated without City inspection, the Contractor shall uncover the services for inspection at no additional cost to the City of Fargo.**

All underground utility excavations not located under City streets shall be backfilled with the same material that is excavated from the trench (clay backfill, unless noted otherwise) compacted to 90% standard proctor density. All material and labor costs necessary shall be included in the appropriate bid items for service closures. In the event that porous material is excavated (sand/gravel), clay backfill shall be imported and placed in the excavation.

For any utility excavation located within a City street, the Contractor will be required to meet the requirements of the City of Fargo excavation permit.



## D. Private utility lines.

- 1) Gas services shall be turned off at existing valves by and under the supervision of the utility company owning the service. Notification of termination of gas service shall be made by the Contractor to the appropriate division of Xcel Energy. Gas will be shut off at the gas main in the street and all gas meters will be removed by the utility company at no cost to the Contractor.
- 2) Disconnect electric wires as per rules and regulations of authorities having jurisdiction. Notification of termination of electric service shall be made by the Contractor to Xcel Energy or Cass County Electric. The respective power company will remove meters, poles, overhead wires, and transformers at no cost to the Contractor.
- 3) Disconnect telephone wires as per rules and regulations of authorities having jurisdiction. Notification of termination of telephone service shall be made by the Contractor to the appropriate serving utility. The telephone company will remove poles and overhead wires, at no cost to the Contractor. Any equipment or wires left by the Telephone Company within the building will be intentional on their part and will be up to the Contractor to remove.
- 4) Disconnect cable television wires as per rules and regulations of authorities having jurisdiction. Notification of termination of cable television service shall be made by the Contractor to the appropriate serving utility.
- 5) The Contractor shall arrange removal of any other wires.
- 6) Maintain and preserve utilities traversing premises as long as same are required.

E. Removal from the basement of all piping, boilers, or other fixtures, and all wood, furniture, rubbish, or other debris. Fuel oil tanks noted in the special instructions and the plans shall be properly disposed of by the Contractor and the cost shall be included in the lump sum demolition price.

- F. All basements indicated shall be filled. Where excavation or open basements are not backfilled within 24 hours, the Contractor will be required to encircle the open area with a temporary safety fence. The fencing shall be orange in color, 4 feet high and constructed of high-density polyethylene and shall be installed in accordance with manufacturer's recommendations. Tensor Corporation fence product No. US 405C or equal can be used.

The Contractor will be required to maintain the safety fencing for the duration of time between demolition and backfilling.

- G. Performance of all other incidental work necessary to fully complete the contract.
- H. Walls over ten feet high of any width or length shall not remain standing after working hours unless adequate lateral support is provided.
- I. Import Fill – Contractor Supply (Clay backfill)

1. This item is for importing clay to backfill the basement excavations.
2. Compaction to 90% standard proctor density is required. The Engineer shall have the backfill tested by an independent testing agency for compaction. The moisture content of the backfill at the time of placement shall be maintained within minus 1% and plus 3% of the optimum moisture content as defined by ASTM D-698. Fill shall be placed in lifts that are not to exceed 12-inches in thickness.
3. All material placed as clay backfill shall be cohesive and consist of material classified by ASTM D2487 as CL or CH. Material shall have not have less than 40% by weight passing the No. 200 sieve and shall have a liquid limit (L.L.) greater than 25 percent and a plasticity index (P.I.) greater than 10 percent. The material shall be free of ice, snow, frozen earth, trash, debris, sod, roots, organic matter or stones larger than 3 inches in any dimension.

4. A soil sample shall be taken to determine if the clay meets the requirements set forth above. The Contractor shall notify the Engineer one (1) week prior to importing fill to obtain a proctor. If the Contractor does not abide by this timeframe and imports fill that does not meet spec he shall remove the nonconforming fill at his own cost.
  5. The Contractor shall notify the Engineer &/or inspector 24 hours prior to hauling. A quantity is listed on the plans for the anticipated amount of clay required for backfilling. Field measurements shall be taken and a quantity shall be estimated in the field. Clay backfill shall be measured as compacted in place quantity.
- J. Thermostats containing mercury must be disposed of into landfills, contingent upon acceptance by the Landfill Authority. Disposal is enhanced by covering the mercury containing device with soil before breaking the mercury container. This helps to bind the mercury with the soil rather than it being released to the atmosphere where the vapor poses a health concern. Any cost associated with the disposal of a thermostat containing mercury shall be included in the demolition bid item.
- K. Site restoration shall consist of fine grading the site using a harley/finish rake to ensure positive drainage and conform to the surrounding sites.
- L. The Contractor shall furnish the disposal site for all demolition materials, non-reusable fill & rubbish. If the Contractor chooses to dispose the material in the City of Fargo Landfill the Contractor will be responsible for all tipping fees.
- M. The Contractor shall take whatever steps necessary to control dust during demolition and removal. **Water shall be sprayed to adequately wet the debris to control dust during the entire demolition process.** The Contractor shall provide the watering equipment or obtain a water meter from the City of Fargo to connect to a fire hydrant to satisfy this requirement. The watering requirement will be waived if temperatures are below freezing.

All trucks hauling demolition debris shall be tarped so construction debris is contained from the demolition site to the disposal site. The Contractor shall

monitor & collect any debris on the haul road associated with the demolition project.

N. PERMITS & NOTIFICATIONS

The Contractor shall provide the Engineer an anticipated construction schedule during the preconstruction meeting. If the construction schedule changes the Contractor shall be required to supply a revised schedule to the Engineer.

The Contractor shall also be required to notify adjoining property owners 48 hours in advance of any parking restrictions/street closings affecting access to their property. This can be accomplished by posting temporary laminated signs in the vicinity of the closure/work zone.

The Contractor shall be responsible for obtaining all permits necessary for demolition of each structure. Permits costs shall be included in the Demolition bid item. Permits shall include but are not limited to:

- Obtaining a demolition permit from the City of Fargo Inspections Department.
- Obtaining all permits from the City of Fargo Engineering Department to transport equipment into and out of each site.
- Completing & submitting a NOI to the North Dakota Department of Health (NDDOH) for storm water discharge.
- Completing & submitting an Asbestos Notification of Demolition and Renovation to the NDDOH; Must be submitted 10 working days prior to the demolition of the structure(s).
- Submitting a Lead-Based Paint Notification of Abatement and Demolition Clearance to the NDDOH; Must be submitted 10 working days prior to the demolition of the structure(s). When submitting this form check yes in box III under the assumption that the structure has lead paint. Fill in all other areas of the form that apply.

If the house is sold by the Contractor to a third party, make note on the notification form that the house will be moved and list the moving date under the renovation work line item.

O. Asbestos Testing

The City of Fargo will hire an outside consultant to test for the presence of asbestos containing building materials. Reports are included as part of the bid package for review by the Contractor.

Asbestos Notification of Demolition and Renovation forms must be completed by the Contractor and submitted to the North Dakota Department of Health.

The cost of obtaining asbestos inspectors or project monitoring firms required during demolition activities for compliance shall be included in the bid item for demolition.

All abatement activities must be conducted in accordance with requirements set forth by the North Dakota Department of Health and the EPA's NESHAP Regulation. The City of Fargo shall not be held responsible if the Contractor fails to abide & comply with the guidelines as stated above.

P. Demolition of Structures with Asbestos:

Recommendations for demolition of structures containing non-regulated, Category 1 non-friable asbestos and regulated asbestos containing materials are provided as part of the bid package in the Asbestos Building Material Survey for each property.

**Regulated asbestos containing materials must be abated prior to commencing demolition activities.** Non-regulated category 1 non-friable asbestos may remain in place during demolition activities if the criteria listed in the Demolition Survey recommendations are adhered to.

The Contractor shall subcontract the removal of regulated asbestos containing materials to an asbestos removal Contractor licensed with the State of North Dakota. The Contractor shall submit to the City of Fargo documentation

certifying that regulated asbestos was removed from the properties and shall follow all rules and regulations regarding asbestos removal. The City of Fargo shall not be held liable for actions or damages caused by the Contractor or his subcontractors if asbestos is not properly removed & disposed during demolition activities.

The Contractor shall notify the City of Fargo landfill when asbestos containing materials will be transported and disposed of at the landfill. The Contractor shall submit a waste manifest form to the landfill when disposing waste containing asbestos. The cost for all landfill tipping fees & subcontracting asbestos abatement shall be included in the bid item for demolition.

Q. LEAD-BASED PAINT

The City of Fargo will not be requiring the Contractor to perform abatement of lead-based paint in any of the structures to be demolished or moved. After the structure & debris have been removed & the site is backfilled, the City will require that a risk assessor perform a visual inspection for any paint chips. Any paint chips found shall be removed from the site by the Contractor & disposed according to all applicable rules & regulations for lead paint disposal. The risk assessor will be coordinated by the Engineer and will not be a cost billed to the Contractor.

In the event that a structure is not demolished and sold to a third party through the Contractor (Contractor becomes the seller of the property), the Contractor will be required under Federal Law to disclose to the buyer that the home (if built pre-1978) possibly has lead paint. The Contractor will be required to hand the buyer a pamphlet entitled: "Protect Your Family from Lead in Your Home" that can be viewed on the EPA's website. A digital copy of the pamphlet can be found at the following internet address:

<http://www.epa.gov/lead/pubs/leadpdf.pdf>

The Contractor (seller) will also be required to have both the buyer and seller of the property sign a document indicating the buyer received the pamphlet on lead paint from the Contractor. The Contractor is required to keep the signed

document for a period of three years in the event that the seller is audited by the EPA. A digital copy of the pamphlet can be found at the following address:

[http://www.epa.gov/lead/pubs/selr\\_eng.pdf](http://www.epa.gov/lead/pubs/selr_eng.pdf)

A copy of the signed document shall be forwarded to the Engineer for the project file.

R. Miscellaneous Solid Waste (MSW)

The previous homeowners were required to remove all belongings from the property. However, some materials may have been left behind and will need to be removed by the Contractor during the demolition process. Disposal of all Miscellaneous Solid Waste (MSW) shall be incidental to the price bid for demolition. This shall also include any items that would need to be properly disposed at a hazardous waste facility.

The Contractor may deposit all hazardous waste material to the City of Fargo Household Hazardous Waste (HHW) at no charge during business hours. The HHW building is located at #606 43 1/2 Street North.

S. House Moving

If a structure containing asbestos is moved to a new location, the Contractor or their subcontractor shall consult with a licensed asbestos Contractor & the North Dakota Department of Health to assess the condition of any asbestos found during the survey. If it is found that asbestos is friable or could become friable during any phase of a move, it must be abated by a licensed abatement Contractor.

After a structure has been moved, a second asbestos survey must be performed to determine if any wall or ceiling texture (or any other asbestos containing material) has become friable if asbestos was not removed prior to the move. If it is found that friable asbestos is present, it must be abated at a cost borne to the Contractor or future owner. The asbestos survey (post move) that explains asbestos containing materials were not disturbed, or that friable asbestos was abated (post move) must be submitted to the City of Fargo upon completion of

the move & inspection. The City of Fargo shall be held harmless and the Contractor shall be liable for any recourse from future owners of the house if the above steps are not followed.

The Contractor or his subcontractor must apply for a moving permit through the City of Fargo Inspections Department prior to removing a structure from its foundation (for structures greater than 120 SF). No structures will be allowed to be lifted off of their foundations or moved until a permit is granted through the Inspections Department. Once the moving permit is granted and the structure is lifted from the foundation it must be moved on the moving date noted on the permit. The Contractor or his subcontractors may not use City right-of-way or property as a temporary storage area for the house once it has been moved from the foundation.

If the structure is not moved by the date noted on the permit the Contractor or his subcontractor shall reapply for a moving permit

T. Clearing & Grubbing

Clearing/grubbing shall be in accordance with Section 1050 of these Specifications.



**SECTION 4**  
**GUARANTEE, MEASUREMENT & PAYMENT**

4.1. GUARANTEE

The guarantee shall be per the contract.

4.2. MEASUREMENT AND PAYMENT

The method of payment shall be as indicated in the contract proposal.

**CITY OF FARGO SPECIFICATIONS  
FLOOD CONTROL LEVEES**

**PART 1  
DESCRIPTION OF WORK**

The work to be done under this section of the Specifications and the accompanying plans consists of furnishing all labor, material, accessories and equipment necessary to construct flood control levees in the City of Fargo. The work includes excavation, filling, compacting, grading and other work as may be necessary in order that the work may be completed in accordance with these Specifications and the accompanying plans.

**PART 2**  
**MATERIAL**

2.1. SOIL MATERIALS

*2.1.1. IMPERVIOUS FILL*

Impervious fill shall be per Section 2000 of these Specifications.

*2.1.2. TOPSOIL*

Topsoil obtained from offsite sources shall be similar to the existing topsoil on site, and shall meet the requirements for TOPSOIL – IMPORT set forth in Section 2000 of these Specifications.

2.2. BORROW MATERIAL

Borrow material shall be per Section 2000 of these Specifications.

**PART 3**  
**CONSTRUCTION**

3.1. GENERAL

The latest editions of the standards listed below, referred to hereinafter by basic designation only, form a part of this section of the Specifications.

- A. American Society of Testing Materials (ASTM)
1. D-1556 “Standard Test Method for Density and Unit Weight of Soil in Place by the Sand Cone Method”
  2. D-698 “Standard Test Methods for Laboratory Compaction Characteristics of Soil Using Standard Effort (12,400 ft-lbf/cu. ft. (600 kN-m/cu.m))”
  3. D-2487 “Standard Practice for Classification of Soils for Engineering Purposes (Unified Soil Classification System)”
  4. D-6938 “Standard Test Method for In-Place Density and Water Content of Soil and Soil-Aggregate by Nuclear Methods (Shallow Depth)”
  5. D-2167 “Standard Test Method for Density and Unit Weight of Soil in Place by the Rubber Balloon Method”
  6. D-2937 “Standard Test Method for Density of Soil in Place by the Drive-Cylinder Method”

3.2. SUBMITTALS

Material test reports shall be acquired for each on-site and borrow soil material proposed for fill. The Contractor shall notify the Engineer one (1) week prior to importing fill to obtain a proctor. If the Contractor does not abide by this timeframe and imports fill that does not meet the requirements of this specification he shall remove the nonconforming fill at his own cost.

### 3.3. TOPSOIL STRIPPING AND RESREADING

The Contractor will be required to strip the topsoil in the permanent levee footprint and also from all excavation areas specifically designated on the plans. Topsoil shall be stockpiled within the construction limits at a location approved by the Engineer. All topsoil stripping and resreading shall be in accordance with Section 1000 of these Specifications.

### 3.4. TEMPORARY CLAY STOCKPILES

Should the Contractor choose to temporarily stockpile clay, all stockpile locations shall be approved by the Engineer. The Contractor shall strip topsoil from the stockpile location prior to stockpiling. Stockpiled material not used during embankment construction shall be incorporated into the site or removed from the site prior to project completion. The Contractor shall restore all stockpile locations to preconstruction conditions by grading, replacing topsoil and seeding/hydro-mulching. All costs for this work shall be incidental to the contract.

### 3.5. INSPECTION TRENCH

Prior to starting the construction of the levee in its permanent location, the Contractor shall excavate an inspection trench along the total length of the proposed levee centerline per the detail shown in the plans. Any pipes, tiles, conduits, buried debris, or other unsatisfactory foundation materials encountered shall be removed from within the footprint of the embankment. The Contractor shall notify the Engineer 48 hours prior to the start of this work.

The inspection trench shall be excavated and maintained free of standing water to the dimensions and locations shown on the plans.

The inspection trench shall be backfilled with material meeting the requirements for Impervious Fill. The excavated material may be used for backfill only if it meets the requirements for Impervious Fill. All backfill shall be placed and compacted as specified below.

### 3.6. UNSUITABLE MATERIAL

The Contractor will be required to remove and dispose of any excavated material determined by the Engineer to be unsuitable for the construction of the embankment or backfilling the inspection trench. Unsuitable materials include, but are not limited to, boulders, timbers, buried building materials, etc.

### 3.7. TREE REMOVAL

Tree removal and clearing/grubbing shall be in accordance with Section 1050 of these Specifications.

### 3.8. EMBANKMENT

Material shall not be placed on surfaces that are muddy, frozen, contain frost, or where unsatisfactory material remains in or under the fill. All soft or yielding material and other portions of the subgrade which will not readily compact shall be removed and replaced with suitable material. The entire subgrade shall then be brought to a line and grade and foundation of uniform compaction which will provide uniform support for fill embankments to be subsequently placed.

The subgrade shall be scarified to a depth of six (6") inches for the full width of the subgrade. The loose materials shall then be spread and manipulated so as to bring all the material to a uniform density.

### 3.9. PLACEMENT, MOISTURE CONTENT AND COMPACTION

Moisture content of the fill at the time of placement shall be maintained within minus 1% and plus 3% of the optimum moisture as defined by ASTM D-698. Application of water to the fill materials may be applied by sprinkling the materials after placement if necessary. Uniform moisture distribution shall be obtained by disking.

Material that is above the optimum moisture content shall either be removed or dried to the specified moisture content prior to compaction. If the top layer of the preceding lift of compacted fill becomes too dry to permit a suitable bond it shall be scarified and moistened by the addition of water to an acceptable moisture content prior to placement of the next lift.

The distribution of materials throughout each zone shall be essentially uniform, and the fill shall be free from lenses, pockets, streaks or layers of material differing substantially in texture or gradation from the surrounding material.

Fill shall be placed in uniform uncompacted lifts not to exceed twelve (12") inches in thickness, and thoroughly mixed by disking or other approved methods to obtain uniformity of material.

Impervious Fill shall be compacted to a minimum density of 95% of the maximum density per ASTM D-698.

Where density and/or moisture content tests do not meet the minimum requirements as set forth above, the Contractor shall remove, replace and compact the embankment material at no additional compensation. A retest shall be required for every test that does not meet the minimum requirements for moisture and/or density. The cost of all retests will be deducted from the Contractor's payment.

If the operation is discontinued, the surface of the previous lift shall be scarified to a minimum depth of 4" prior to placing additional lifts. Fill adjacent to structures shall be compacted to a density equivalent to that of the surrounding fill by means of hand tamping, or manually directed power tampers or plate vibrators. Heavy equipment and/or vibrating equipment shall be kept a sufficient distance away from structures to avoid damage to the structure. The Contractor shall employ a non-destructive compaction effort to compact soil adjacent to structures. The Contractor is responsible for any/all damage caused by his equipment and/or forces. Compaction by means of drop weights operating from a crane hoist will not be permitted.

Embankment shall not be constructed during periods when the embankment material freezes while being placed and compacted, nor shall any embankment material be placed on soil that is frozen. Where the foundation soil is frozen at a time when weather conditions are such that embankment construction could be continued without the material freezing as it is being placed and compacted, the Contractor may be permitted to excavate the frozen foundation soil and proceed with the embankment construction for so long as the weather will permit, but only if and to the extent approved by the Engineer, and with the understanding that the additional costs involved shall be at the expense of the Contractor. The frozen soil shall be removed and replaced with other suitable soil as may be necessary to construct the embankment specified.

### 3.10. TERRACING/BENCHING

The Contractor will be required to bench into existing embankments on any slopes greater than 5:1 prior to placement of any additional fill. The benching shall be completed in such a manner to ensure that a minimum vertical face of 18-inches is exposed for the compaction of the new horizontal layer. The vertical face shall not exceed 30-inches in height.

3.11. TESTING/QUALITY CONTROL

During the course of the work, the Engineer will perform such quality assurance tests as are required to identify materials; determine compaction characteristics; determine moisture content; and determine density of fill in place. Tests performed by the Engineer are intended to verify conformance with the contract requirements, not to be a replacement for the Contractor's quality control program.

Densities of fill requiring compaction will be determined in accordance with the appropriate ASTM methods which may include ASTM D-1556 (Sand Cone Method), D-2167 (Balloon Method), D-6938 (Nuclear Methods), D-2937 (Drive Cylinder Method) and other methods approved by the Engineer. The Engineer will determine the density test which is appropriate for the conditions and materials encountered.



**PART 4**  
**GUARANTEE, MEASUREMENT & PAYMENT**

4.1. GUARANTEE

The guarantee shall be per the contract.

4.2. MEASUREMENT AND PAYMENT

*4.2.1. IMPORTED FILL*

Measurement and payment will be per the contract unit price based on the in place compacted cubic yardage quantity. The quantity will be determined by surveying the levee and subtracting the in place fill from existing ground elevations.

*4.2.2. INSPECTION TRENCH*

Measurement and payment will be per the contract unit price per CY, which shall be compensation in full for all equipment, materials, and labor necessary to complete the work as specified. The inspection trench shall be measured in the field for material excavated and replaced.

*4.2.3. STRIP TOPSOIL*

Measurement and payment will be per Section 1050 of these Specifications.

*4.2.4. REMOVE TREE*

Measurement and payment shall be as per section 1050 of these Specifications.

*4.2.5. STOCKPILING*

All work associated with stockpiling shall not be measured for separate payment, but shall be considered incidental to the contract.

*4.2.6. UNSUITABLE MATERIAL*

Payment for disposal of unsuitable material shall be addressed as “Extra Work” in accordance with Section 9000 of these Specifications.

*4.2.7. OTHER COSTS*

All costs for work necessary to properly complete the work specified herein shall not be bid items; the costs shall be charged to other items unless a bid item is included on the bid sheet.

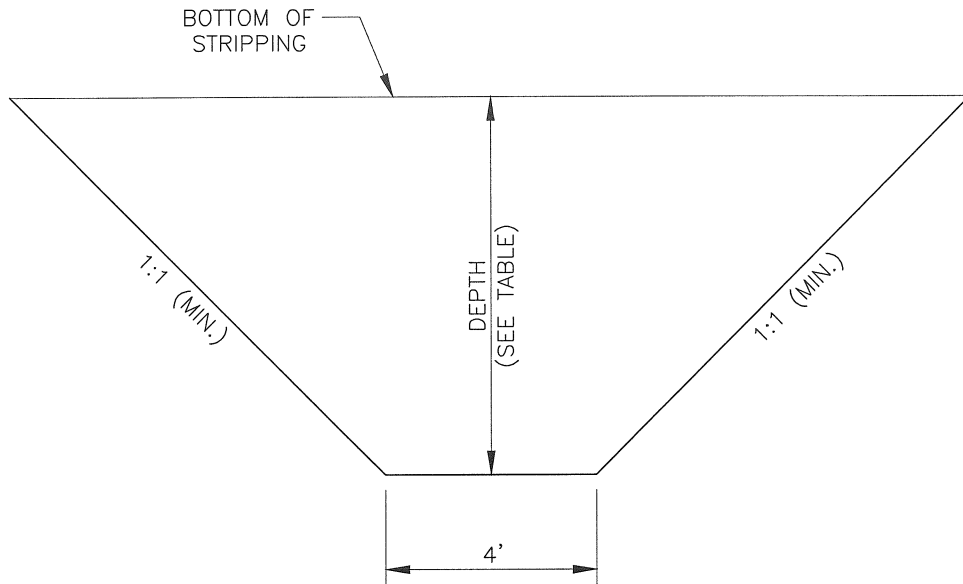

INSPECTION TRENCH DEPTH	
LEVEE HEIGHT	DEPTH
0' TO 6'	EQUAL TO HEIGHT OF LEVEE (3' MIN.)
6' OR HIGHER	6'

SECTION NO. 3600	DRAWING NO. 5.1
REV.D. 2012	
<b>INSPECTION TRENCH</b>	
CITY OF FARGO ENGINEERING DEPARTMENT	
APPROVED <i>BED</i>	DATE <i>2-21-2012</i>

**CITY OF FARGO SPECIFICATIONS  
PAVEMENT MARKINGS**

**PART 1  
DESCRIPTION OF WORK**

This work to be done under this section of the Specifications and the accompanying plans consists of furnishing and installing the specified pavement markings at the designated locations in the City of Fargo.

**PM Certification Requirement**

Permanent pavement markings shall be applied in accordance with the manufacturer's recommendations. All Contractors installing the material for the City shall provide a crew of which 50% are trained and "certified" by the manufacturer. "Certified" Contractors must be able to provide proof of the certification through a manufacturer provided ID Card or Certification Paper.

Permanent pavement marks shall include but are not limited to plastic pavement marking film, preformed thermoplastic pavement markings, durable methacrylate markings and epoxy pavement marking paint.

**PART 2  
MATERIAL**

**2.1. PAVEMENT MARKING PAINT**

**A. Color**

The marking paint shall be white, yellow or blue conforming to standard highway colors.

**B. Physical Requirements**

The paint shall meet NDDOT specifications for high solids water-based traffic paint. The Contractor shall submit certification of the paint prior to placement.

**C. Glass Beads**

Glass beads for pavement markings shall conform to the specifications required by the respective paint manufacturer with which the paint material complies.

**2.1.1. PAINT APPLICATION EQUIPMENT**

The equipment required to apply pavement marking paint and glass beads shall be a self-propelled, pneumatic spraying machine with atomizing nozzles capable of applying three 4-inch to 8-inch wide lines at one time. The spray mechanism shall be operated by quick opening and closing valves. The applicator shall apply the materials at a rate specified in an even and uniform thickness with clearly defined edges. The applicator shall have reservoirs or tanks equipped with agitators capable of keeping the material in a smooth, even mixture. Tanks shall have sufficient capacity to apply the materials as specified. The applicator shall be equipped with an automatic skip control device capable of applying a stripe of specified length with a linear tolerance of 3 inches. The applicator shall be capable of retracing and applying materials to traffic markings in place.

Adequate hand-operated equipment will be required to accomplish the pavement markings for areas not readily accessible to the pavement marking applicator.

The machine shall be equipped with a glass bead dispenser adjusted and synchronized with the paint applicator to distribute the reflectorizing spheres uniformly on the painted line(s) using air pressure. The bead dispenser shall be equipped with an automatic cutoff control, synchronized with the cutoff of the striping material.

The applicator truck (striper) shall have a permanently mounted, direction variable early warning arrow board visible to approaching traffic. Truck equipment shall be capable of accumulating the footage applied by each gun individually each day. Only material application shall activate the footage accumulators. The read out shall be digital and not adjustable.

2.2. PLASTIC PAVEMENT MARKING FILM

The prefabricated plastic pavement markings shall consist of white or yellow pigmented plastic films, conforming to standard highway colors, with reflective glass spheres incorporated throughout the entire cross-sectional area and a layer of reflective glass spheres bonded to the top surface. The pavement markings shall adhere to bituminous or Portland cement concrete pavements by either a pressure-sensitive precoated adhesive or a liquid contact cement. The markings shall be provided in a form that will facilitate rapid application and protect the markings in shipment and storage. The manufacturer shall identify proper solvents and/or adhesives to be applied at the time of application, all equipment necessary for proper application and recommendations for application that will assure an effective performance life. The marking material shall mold itself to pavement contours by the action of traffic. The pavement marking films shall also be capable of application on new bituminous concrete wearing courses during the paving operation according to the manufacturer's instructions. After application, the markings shall be immediately ready for traffic.

Prefabricated legend and symbols shall conform to the applicable shapes and sizes shown in the "Manual on Uniform Traffic Control Devices."

All plastic marking film required shall be 3M Stamark 380AW & 381AW Durable Pavement Marking Tape. The Contractor may provide equivalent materials from other manufacturers only if the material has been approved in writing by the Engineer.

2.3. PRE-FORMED THERMOPLASTIC PAVEMENT MARKINGS

- A. The markings must be a resilient white or yellow thermoplastic product with uniformly distributed glass beads throughout the entire cross sectional area. Lines, legends and symbols are capable of being affixed to bituminous and/or Portland concrete pavements by the use of the normal heat of a propane type of torch. Other colors shall be available as required.
- B. The markings must be capable of conforming to pavement contours, breaks and faults through the action of traffic at normal pavement temperatures. The markings shall have resealing characteristics, such that it is capable of fusing with itself and previously applied thermoplastic when heated with the torch.
- C. The markings must be able to be applied in temperatures down to 32 degrees F. without any special storage, preheating or treatment of the material before application.
- D. Must be composed of ester modified resin resistant to degradation by motor fuels, aggregates, pigments, binders and glass beads which have been factory produced as a finished product and meets the requirements of the current edition of the Manual on Uniform Traffic Control Devices for Streets and Highways. The thermoplastic material conforms to AASHTO designation M249-79(86), with the exception of the relevant differences due to the material is supplied in a preformed state.

- E. **Graded Glass Beads:**  
The material must contain a minimum of thirty percent (30%) intermixed graded glass beads by weight. The intermixed beads shall be clear and transparent. Not more than twenty percent (20%) consist of irregular fused spheroids, or silica. The index of refraction shall not be less than 1.50.
- The material must have factory applied coated surface beads in addition to the intermixed beads at a rate of 1 lb. ( $\pm 10\%$ ) per 11 sq. ft.
- F. **Pigments:**  
White: Sufficient titanium dioxide pigment is used to ensure a color similar to Federal Highway White, Color No. 17886, as per Federal Standard 595.
- Yellow: Sufficient yellow pigment is used to ensure a color similar to Federal Highway Yellow, Color No. 13655, as per Federal Standard 595. The yellow pigment must be of an organic nature only and contain no lead chromate.
- G. **Skid Resistance:**  
The surface, with proper applied and embedded surface beads, must provide a minimum resistance value of 50 BPN when tested according to ASTM E 303.
- H. **Thickness:**  
The material must be supplied at a minimum thickness of 125 mils (3.15mm).
- I. **Versatility:**  
No glass beads must be applied on the surface of the material before application, as the material shall be able to be placed on the pavement either side up. For instance: Should an arrow, either left or right, be desired, only one arrow needs to be purchased. It is also true of combination arrows and other legends where applicable.
- J. **Environmental Resistance:**  
The material must be resistant to deterioration due to exposure to sunlight, water, oil, gasoline, salt or adverse weather conditions.

#### 2.4. EPOXY PAVEMENT MARKING PAINT

- A. **Composition Requirements**  
The epoxy resin composition shall be specifically formulated for use as a durable pavement marking material and for hot spray application at elevated temperatures not exceeding 150° F. The type and amounts of epoxy resins and curing agents shall be at the option of the manufacturer, providing the other composition and physical requirements of this specification are met.

The marking material shall be a two-component (Part A and Part B), 100% solids type system formulated and designed to provide a simple volumetric mixing ratio (e.g. two volumes of Part A to one volume of Part B).

The component A of both white and yellow shall be within the following limits:

	<u>WHITE</u>	<u>YELLOW</u>
Pigments		
--Titanium Dioxide (ASTM D-476-73 Type II & III)	18-25%	--
--Chrome Yellow (ASTM D-211-67(73) Type III)	--	23-30%
Binder		
--Epoxy Resin*	75-82%	70-77%

\*NOTE: Epoxy resin binder must be completely free of TMPTA (Tri-Methylol Propane Tri-Acrylate) and other multi-functional monomers.

Epoxy Number: The epoxy number of the epoxy resin shall be  $0.40 \pm 0.1$  as determined by ASTM D-1652 for both white and yellow Component A on a pigment free basis.

Amine Number: The amine number of the curing agent (Component B) shall not be less than 400 as per ASTM D-2074-66(76).

Toxicity: The material shall not exude fumes, which are toxic or injurious to persons or property.

#### B. Physical Properties of End Product

Unless otherwise noted, all samples are to be prepared and tested at an ambient temperature of  $73 \pm 5^\circ\text{F}$ .

##### 1. Color and Weather Resistance:

The mixed epoxy compound, both white and yellow, when applied to 3" x 6" aluminum panels at  $15 \pm 1$  mil in thickness with no glass beads and exposed in a Q.U.V. Environmental Testing Chamber, as described in ASTM G-53-77, shall conform to the following minimum requirements. *(The test shall be conducted for 75 hours at  $50^\circ\text{C}$ ., 4 hours humidity and 4 hours U.V., in alternating cycles.*

*The prepared panels shall be cured at  $77^\circ\text{F}$ . for 72 hours prior to exposure.)*

The color of the white epoxy system shall not be darker than Federal Standard No. 595A-17778. The color of the yellow epoxy system shall be reasonably close to Federal Standard No. 595A-13538.



2. **Directional Reflectance**  
The white epoxy composition (without glass spheres) shall have a daylight directional reflectance of not less than 84% relative to a magnesium oxide standard when tested in accordance with ASTM E-97.
- The yellow composition (without glass spheres) shall have a daylight directional reflectance of not less than 55% relative to a magnesium oxide standard when tested in accordance with ASTM E-97.
3. **Drying Time (Field)**  
The material used shall be Type II – slow dry material Mark 55 as manufactured by Polycarb, Inc. or LS 60 as manufactured by Epoplex. The Contractor may provide equivalent materials from other manufacturers only if the material has been approved in writing by the Engineer. It shall be in a “no tracking” condition in 45 minutes or less. “No tracking” condition shall be determined by actual application on the pavement of the pigmented binder at 20 mils wet, covered with glass beads at the rate of 30 pounds per gallon. No visual deposition of the epoxy marking to the pavement surface shall be visible from a distance of 50 feet after a vehicle’s tires have passed over the line.
4. **Abrasion Resistance**  
The wear index of the epoxy composition shall not exceed 82 mg when tested in accordance with ASTM C501 using a CS-17 wheel and under a load of 1000 grams for 1000 cycles.
5. **Hardness**  
The epoxy composition when tested in accordance with ASTM D2240 shall have a Shore D hardness of between 75 and 100. Samples shall be allowed to cure for not less than 72 hours nor more than 96 hours prior to testing.
6. **Adhesion to Concrete**  
The catalyzed epoxy pavement marking materials, when tested according to ACI Method 503, shall have such a high degree of adhesion to the specified (4,000 psi minimum) concrete surface that there shall be a 100% concrete failure in the performance of this test. The prepared specimens shall be conditioned at room temperature (75±2°F.) for a minimum of 24 hours and a maximum of 72 hours prior to the performance of the tests indicated.
7. **Adhesion to Asphalt**  
100 % failure in asphalt ACI-503

C. **Reflective Media**

All Epoxy markings shall use a Glass bead that meets the following requirements: All beads shall be coated. The Drop-On glass beads shall be a double drop system comprised of:

1. Particle-1, a conglomerate bead visible in wet night conditions, pigmented to match the binder and initial color shall fall within the color box coordinates below:

WHITE

X	.355	.305	.285	.335
Y	.355	.305	.325	.375

YELLOW

X	.475	.490	.495	.520
Y	.450	.433	.475	.450

Crush Strength – The crush strength of the glass or ceramic bead system is important for the long life of the marking, the beads and elements shall resist crushing to 30,000 psi minimum when tested according to ASTM Method D 1213-54.

2. Particle-2, AASHTO M247 Type 1 bead or as approved by the Engineer and binder manufacturer.
3. Drop-On Reflective Bead System:  
The high reflective bead system and AASHTO M-247 TYPE 1 glass spheres, as described under part A & B shall be applied in a double drop operation. Particle-1 shall be applied first from the bead dispenser directly behind the marking application gun followed immediately by the application of Particle-2 AASHTO M-247 TYPE 1 beads from a second bead dispenser. The application rates of each of the reflective media shall conform to the manufacturer of the marking and the manufacturer of the bead system suppliers and be approved by the Engineer in the field. The application rate shall be 3 lbs. per gallon for Particle-1 and 25 lbs. per gallon for Particle-2.

*2.4.1. APPLICATION EQUIPMENT*

In general, the applying equipment shall be mobile, truck mounted and self contained pavement marking machine, specifically designed to apply epoxy materials and reflective glass spheres in continuous and skip-line patterns. The applying equipment shall be maneuverable to the extent that straight lines can be followed and normal curves can be made in a true arc. In addition, the truck-mounted unit shall be provided with accessories to allow for the marking of legends, symbols, crosswalks, and other special patterns.

The Engineer and the material manufacturer together may approve the use of a portable applicator in lieu of truck mounted accessories, for use in applying special markings only, provided such equipment can demonstrate satisfactory application of reflectorized markings in accordance with these Specifications.

The mobile applicator shall include the following features:

- A. The mobile applicator shall provide individual material reservoirs, or space, for the storage of Part A and Part B of the resin composition.
- B. The applicator shall be equipped with heating equipment of sufficient capacity to maintain the individual resin components at the manufacturer's recommended temperature for spray application.
- C. The applicator shall be equipped with glass bead dispensing equipment and capable of applying the spheres at the rate of 3 lbs. per gallon for particle-1, and 25 lbs. per gallon for particle-2 of epoxy resin composition.
- D. The applicator shall be equipped with metering devices or pressure gauges on the proportioning pumps, as well as stroke counters to monitor gallon usage. Metering devices or pressure gauge and stroke counters shall be visible to the Engineer.
- E. The applicator shall be equipped with all the necessary spray equipment, mixers, compressors, and other appurtenances to allow for the placement of reflectorized pavement markings in a simultaneous sequence of operations.
- F. The application equipment must have a minimum of a 24" long static mixer unit as manufacture by Kenics Company or equal for proper mixing of the two components, or other mixing apparatus equivalent in performance and certified by the epoxy manufacturer.
- G. The mobile applicator must be equipped with a completely enclosed flush and purge system to clean the lines and the guns without exuding any solvents into the environment.

#### 2.4.2 EPOXY PAINT MARKING MONITORING SYSTEM

This specification adds a computerized Data Logging System (DLS) for monitoring the application of striping to the roadway. DLS is an addition to striping equipment to record data relating to pavement marking installation.

##### A. **CONSTRUCTION REQUIREMENTS**

All striping operations shall be completed in accordance to the latest version of the City of Fargo Specifications. The system shall document for a minimum length of 300 linear foot intervals for the entire striping project. The following data shall be included in the documentation from the DLS:

1. Application vehicle speed to nearest 0.1 MPH,
2. Weight (LBS) and/or volume (GAL as measured through a piston displacement pump mechanism) amount of paint material used by color,
3. Weight (LBS) of reflective material used, excluding wet reflective elements.
4. Pavement surface temperature (°F),
5. Air temperature (°F),
6. Dew point (°F),
7. Humidity (%),
8. The system shall record the average material application rates and film thickness calculated over the section painted.
9. For every roadway striped, the street or avenue with beginning and ending reference of the intersecting street or avenue and all information listed above.

An electronic or printed record of the data shall be provided to the Engineer, daily or at the end of each project area. The Engineer may determine that more frequent submission is necessary, particularly if equipment malfunctions occur. Either the printed or electronic records shall be produced in their final form prior to the records being removed from the striping equipment (i.e. the Contractor presents this it to the Engineer, in the field). If only one record is produced at the striping equipment, the other may be produced in an office. However, the first record shall be presented to the Engineer prior to any of the data entering an office environment. The electronic record shall be a comma or spaces delimited text file, adequate for insertion into a computerized spreadsheet software package or a spreadsheet format acceptable to the Engineer.

The Contractor shall provide the Engineer the above records for all longitudinal non-handwork lines painted.

The Contractor shall have equipment with functional DLS equipment. It shall be operational, calibrated and in use during striping operations.

The Contractor shall provide the Engineer the DLS manufacturer's recommendations for equipment calibration frequency and provide certification that the equipment meets manufacturer's recommended calibration.

A 100 foot distance shall be traveled prior to the start of striping operations to verify the physical and electronic measurement of distance traveled is consistent.

**B. METHOD OF MEASUREMENT**

DLS will not be measured. Pavement Markings will be measured by the linear foot of the various widths of the installed line, complete, in place, and accepted. Only marked portions of broken lines will be measured.

**C. BASIS OF PAYMENT**

All manufacturer representation, labor, equipment, reports, documentation, DLS, and materials necessary to furnish and install the pavement marking shall be included in the price bid for "Paint \_\_\_\_ inch Epoxy" LF

At any time throughout the duration of the project, the Contractor shall provide free access to his applying equipment for inspection by the Engineer, his authorized representative, or the materials representative.

2.5. DURABLE METHACRYLATE ROAD MARKINGS**A. GENERAL**

All Durable Methacrylate Markings shall be grooved in the pavement. Groove depth shall be 120 mils in depth with a light sand blast applied after grooving to rough up the surface. Material thickness shall be 120 mils thick and fill the entire groove. Glass beads shall be applied at a minimum of 35 PSI to the marking as per "Glass Beads" specification using a sand blasting machine.

## 1. Work included

- a. Work described in this section includes surface preparation and permanent installation of methacrylate road markings ("Markings") on asphalt or concrete pavements.
- b. Markings shall be installed within the limits of the project as shown on the plan drawings or as directed by the Engineer in the field.

## 2. System Description

- a. Marking shall be plural-component, liquid-applied methacrylate material capable of full cure without external heat sources. Binder resins shall be 100% reactive, solvent-free and highly elastic to accommodate various pavement conditions. Configurations may include extruded high-build markings or if approved by the Engineer in the field spray-applied thin-mil markings.
- b. Markings shall be applied on properly prepared pavements or over properly prepared existing methacrylate materials.
- c. Methacrylate spray markings may be used as (a) an underlayment to produce a contrast for concrete pavements-e.g. white markings on black underlayment – or (b) a renewal coat for worn or damaged Markings.

### 3. Quality Assurance

#### a. Supplier Qualifications

1. Binder- Acceptable binder resins shall be supplied by companies with a minimum of 10 years of commercial experience in the production, sales and technical support of methacrylate reactive resins serving the road marking industry. Companies shall be certified to ISO9001 and ISO14001.
2. Marking – Acceptable markings shall be supplied by companies (“Manufacturer”) with a minimum of 10 years of commercial experience in the production, sales and technical support of road marking materials. Manufacturers shall be certified by the supplier of binder resins.
  - a. Under no circumstances shall the manufacturer be allowed to alter the formulation of previously submitted and approved materials. Any changes shall result in forfeiture of eligibility and require re-submittal for approval.
  - b. Requests for substitution shall be considered only for products that appear on the qualified products list and only if submitted within 10 days after the execution of the contract. No request for substitution shall be considered that would change the generic type of Marking specified.

#### b. Contractor/Sub Contractor Qualifications

1. Each Contractor or Sub-Contractor responsible for the work on this project shall be pre-qualified and certified by the Manufacturer at the time of installation. Acceptability shall include judgment on equipment capabilities, application history and financial stability. Only those Contractors certified by the Manufacturer shall be allowed to apply Markings. In no case shall the Manufacturer permit the installation of Markings by untrained, non-certified Contractors.
2. Each certified Contractor shall have been trained by the Manufacturer in phases of surface preparation and installation of specified Markings.
3. Contractors shall provide only plural-component equipment certified by the manufacturer and designed specifically for the purpose of applying Markings to a uniform nominal width and thickness on the pavement. Hand units shall be allowed with the approval of the project Engineer. Automatic equipment shall be capable of installing a double center line or single edge line in one pass. Automatic bead applicators shall be required for all applications.

4. Reference Standards
  - a. ASTM D2240 - Test Method for Rubber Property - Durometer Hardness
  - b. ASTM D4541 - Method for Pull-Off Strength of Coatings using Portable Adhesion Testers
  - c. ASTM E303 – Test Method for Measuring Surface Frictional Properties Using the British Pendulum Tester
  - d. ASTM E1710 – Test Method for Measurement of Retro reflective Marking Materials with CEN-Prescribed Geometry Using Portable Retro Reflectometer.
  - e. 40 CFR 59 Subpart D Appendix A – Determination of Volatile Matter Content of Methacrylate Multicomponent Coatings Used as Traffic Marking Coatings.
  - f. FHWA “Manual on Uniform Traffic Control Devices”(MUTCD)
5. Submittals
  - a. An acceptance sample of the Marking applied to aluminum or similar backing for rigidity and ease of handling.
  - b. Manufacturer’s literature and MSDS for each product to be used.
  - c. Contractor certification by the Manufacturer.
  - d. Manufacturer certification by the binder resin supplier.
  - e. ISO certification for the binder resin supplier.
6. Delivery, Storage and Handling
  - a. All materials shall be in the Manufacturer’s sealed containers with all pertinent labels intact and legible.
  - b. Materials shall be kept in dry protected areas between 40 degrees to 80 degrees Fahrenheit, out of direct sunlight, protected from open flame and with all containers grounded. Hardener component shall be stored separately from other materials.
  - c. Manufacturer’s specific label instructions and prudent safety practices for storage and handling shall be followed at all times.

- d. The Markings shall be suitable for use for six months after the date of receipt when stored in accordance with the Manufacturer's instructions.

7. Project and Site Conditions

- a. Air temperatures shall be in the range of 35 degrees to 75 degrees Fahrenheit during installation and cure. Application temperatures outside this range require the agreement of the project Engineer, and must be in accordance with the Manufacturers recommendations and may only be made with Markings on the qualified products list.
- b. Relative humidity in the specific location of the installation shall be less than 85% and the surface temperature shall be at least 5 degrees Fahrenheit above the dew point.
- c. The pavement shall be dry and rain-free 24 hours prior to installation.
- d. Asphalt pavements shall be dry, clean and free of contaminants such as surface oils. Newly placed asphalt pavements shall be allowed to age a minimum of 14 days prior to application of Markings.
- e. Concrete must be fully cured for a minimum of 28 days prior to installation of Markings. Surface contaminants such as curing agents, membranes, bond breakers or laitance shall not be allowed. Moisture content shall not exceed 0.5%.
- f. Any presence of existing markings are also deemed contaminants and shall not be allowed. Placement of Markings over existing methacrylates shall be allowed with the approval of the project Engineer. Existing Methacrylate marking must be sand blasted or surface prepped and blown clean before the placement of methacrylate will be allowed.

B. PRODUCTS

- 1. Binders-100% methacrylate reactive resin. Blends with other resins or liquid vehicles shall not be permitted.
- 2. Markings
  - a. Extruded Methacrylate Marking – Plural-component methacrylate compound applied using walk-behind stripers, masking off area and pouring the material in the groove and spreading the material out with a metal concrete rake or automatic extrusion equipment. Markings shall contain intermix beads. Where raised profiles are required, profile shape, height and interval shall be in accordance with the plan drawings.



- b. Spray Methacrylate Marking – Plural-component methacrylate compound applied using automatic spray equipment. Markings do not require intermix beads. When required, spray Markings shall also serve as an underlayment. Spray markings must get approval by the Engineer in the field prior to being used.
3. Markings – Plural-component, liquid applied methacrylate material installed using equipment capable of producing an agglomerate pattern. Markings shall contain intermix beads.
  4. Auxiliaries – The following products shall be provided by the Manufacturer and used in accordance with the Manufacturer’s recommendations.
    - a. Primer – Plural-component, 100% reactive methacrylate resin.
    - b. Hardener – 50% dibenzoyl peroxide powder or 40% liquid dispersion.
    - c. Glass Beads
      1. Appearance – Beads shall transparent, clean, dry, free-flowing, free from air inclusions and foreign matter including carbon residues.
      2. Size – Bead size shall be in accordance with the Manufacturer’s recommendation.
      3. Manufacture – Beads shall be produced as a result of directly spherodizing glass from a molten glass tank. Any component of the batch process utilizing recycled glass shall be sourced from North American waste streams.
      4. Coating – Methacrylate compatible silane coupling agent. Other silanes, moisture-proof or flotation coatings shall not be permitted.
      5. Refractive index – Beads shall have a refractive index of 1.5 or higher as required to meet the minimum retro reflectivity levels for the prescribed period.

Particle-1, a conglomerate bead visible in wet night conditions, pigmented to match the binder and initial color shall fall within the color box coordinates below:

WHITE

X	.355	.305	.285	.335
Y	.355	.305	.325	.375

YELLOW

X	.475	.490	.495	.520
Y	.450	.433	.475	.450

- 6. Crush Strength – The crush strength of the glass or ceramic bead system is important for the long life of the marking, the beads and elements shall resist crushing to 30,000 psi minimum when tested according to ASTM Method D 1213-54.
- 7. Particle-2, AASHTO M247 Type 1 bead or as approved by the Engineer and binder manufacturer.
- 8. The application rate shall be .066 lbs. per 100 square feet for Particle-1 and 6 lbs. per 100 square feet for Particle-2.

5. Marking Performance Criteria

Property	Value
Extrude marking Thickness	Minimum 60 to a maximum of 120 mils as specified
Profile Height	Maximum 120 mils as specified
Spray Marking Thickness	Minimum 60 to maximum of 120 mils as specified
Tolerance	-0/+10 mils extrude, -0/+10 mils spray
Cure Time	Tack-free within 10-45 minutes depending on temperature
VOC Emissions	Less than 150 g/l
Adhesion	Minimum 250 psi or pavement failure
Shore Hardness	Minimum 50D after 24 hours
Bead Application Rate	As per specification
Dry Retro reflectivity	Initial* minimum 300 mcd/lx/m2 white Initial* minimum 200 mcd/lx/m2 yellow
Skid Resistance	Initial* minimum 45
Chemical Resistance	Cured markings shall be resistant to calcium, chloride, sodium chloride, fuels, oils and UV effects

\* Defined as 3-14 days after placement

**PART 3  
CONSTRUCTION**

3.1. INSTALLATION OF EACH MATERIAL TYPE

A. PAINT

At the time of applying the marking material, the application area shall be free of all contamination, including oil, dirt, grease, curing compound and other matter that might adversely affect adhesion or durability of the marking material.

The Contractor's equipment shall be capable of cleaning the pavement surface of loose dirt, sand, gravel, etc. by the application of compressed air immediately ahead of the marking application. Areas with heavy accumulation of contaminants, which cannot be removed with compressed air, shall not be painted until the pavement surface has been cleaned and shall be painted within 1 hour of the cleaning operation. The Engineer will determine which pavement surfaces are too contaminated for painting.

The paint marking application shall immediately follow the pavement cleaning. Glass beads shall be applied within 3 seconds after application of the painted line.

B. PLASTIC PAVEMENT MARKING FILM.

1. The work shall generally consist of planing the concrete or asphalt surface and subsequent application of pavement marking tape into the planed area.
2. The groove shall be made in a single pass dry cut using stacked diamond cutting heads mounted on a floating head with controls capable of providing uniform depth and alignment. The equipment shall be self-vacuuming, be capable of vacuuming and containing all dust contaminants from entering the air, and leave the cut groove ready for pavement marking installation. If the Engineer in the field deems that the Contractor's dust collection is not adequate then the Engineer may shut down the Contractor's operation until the Contractor has fixed the problem according to the satisfaction of the Engineer. The equipment and method used shall be approved by the pavement marking manufacturer. The bottom of the groove shall have a fine corduroy finish. If a course tooth pattern is present, increase the number of blades and decrease the thickness of the spacers on the cutting head. The pavement marking shall be placed in the grooves the same day as the cut. Grooves shall be clean and dry prior to pavement marking application.

Cutting head: Gang stacked 1/8 to 1/2 inch wide diamond tipped cutting blades.

The spacers between each blade must be such that there is less than a 10-mil raise in the finished groove between the blades.

- Groove width: Tape width + ½ inch (+/- 1/8 inch).
- Groove depth: 120 mils
- Groove length: Full length of marking + 3 inch grooving transition on either end.
- Groove position: Minimum of 2 inches from the edge of the longitudinal seam.
- Finished surface: The bottom of the groove should have a fine corduroy surface. If a course tooth pattern is present, increase the number of blades and decrease the thickness of the spacers used on the cutting head.
- Groove cleaning: Grooves must be cleaned by using high-pressure compressed air with a 185 cfm air compressor or greater at a pressure of at least 80 psi. A leaf blower will NOT be an acceptable substitute for compressed air.

3. If the tape installation does not immediately follow dry pavement grooving, the following shall apply; within 24 hours prior to placing the primer and tape, the groove shall be sandblasted and free of any residue and laitance. If the primer and tape are not placed within 24 hours of sandblasting, the groove shall be re-sandblasted.

The primer and tape shall be installed in accordance with the manufacturer's recommendations.

4. Existing Tape And Epoxy

Any existing tape or epoxy that is to be replaced by new tape shall be removed, by the Contractor, before grooving or laying new tape in the groove. No additional compensation shall be given for doing this and it shall be incidental to the price bid for "Grooved Plastic Marking Film".

#### C. PREFORMED THERMOPLASTIC

1. The work shall generally consist of planing the concrete or asphalt surface and subsequent application of preformed thermoplastic into the planed area.
2. The groove shall be made in a single pass dry cut using stacked diamond cutting heads mounted on a floating head with controls capable of providing uniform depth and alignment. The equipment shall be self-vacuuming, be capable of vacuuming and containing all dust contaminants from entering the air, and leave the cut groove ready for pavement marking installation. If the Engineer in the field deems that the Contractor's dust collection is not adequate then the Engineer may shut down the Contractor's operation until the Contractor has fixed the problem according the satisfaction of the Engineer. The equipment and method used shall be approved by the pavement marking manufacturer. The bottom of the groove shall have a fine corduroy finish. If a course tooth pattern is present, increase the number of blades and decrease the thickness of the spacers on the cutting head. The pavement marking

shall be placed in the grooves the same day as the cut. Grooves shall be clean and dry prior to pavement marking application.

- Cutting head: Gang stacked 1/8 to 1/2 inch wide diamond tipped cutting blades.  
The spacers between each blade must be such that there is less than a 10-mil raise in the finished groove between the blades.
- Groove width: Thermoplastic width + 1/2 inch (+/- 1/8 inch).
- Groove depth: 75% of tape thickness (+/- 15%).  
Example: (Thermoplastic that is 125 mils thick): 95 mils (+/- 15% of 95 mils).
- Groove length: Full length of marking + 3 inch grooving transition on either end.
- Groove position: Minimum of 2 inches from the edge of the longitudinal seam.
- Finished surface: The bottom of the groove should have a fine corduroy surface.  
If a course tooth pattern is present, increase the number of blades and decrease the thickness of the spacers used on the cutting head.
- Groove cleaning: Grooves must be cleaned by using high pressure compressed air with a 185 cfm air compressor or greater at a pressure of at least 80 psi. A leaf blower will NOT be an acceptable substitute for compressed air.

3. If the thermoplastic installation does not immediately follow dry pavement grooving, the following shall apply. Within 24 hours prior to placing the thermoplastic, the groove shall be sandblasted and free of any residue and laitance. If the thermoplastic is not placed within 24 hours of sandblasting, the groove shall be re-sandblasted.
4. The primer and thermoplastic shall be installed in accordance with the manufacturer's recommendations.

#### D. EPOXY

1. The pavement surface shall be surface planed. All long line preparation shall be accomplished with self propelled equipment capable of following a straight longitudinal line.
2. Planed width shall be Epoxy width +2" on all sides. Preparation method must be approved by the Engineer before the surface can be planed, ensuring no damage is done to pavement. No carbide or diamond tip blades or wheels are allowed.
3. At the time of applying the marking material, the application area shall be free of all contamination, including oil, dirt, grease, curing compound and other matter that might adversely affect adhesion or durability of the marking material.

4. The Contractor's equipment shall be capable of cleaning the pavement surface of loose dirt, sand, gravel, etc. by the application of compressed air immediately ahead of the marking application.
5. The paint marking application shall immediately follow the pavement cleaning.
6. Epoxy Pavement Surface Preparation

The pavement shall be planed or sandblasted and shall be the width of the epoxy marking +2" on all sides. All asphalt pavements with an existing seal coat/chip seal must be surfaced prepped by means of sandblasting. Preparation method must be approved by the Engineer before the surface can be planed, ensuring that no damage shall be done to the pavement. No carbide or diamond tip blades or wheels are allowed on surface preparation equipment. No surface preparation will be required on new asphalt that is less than 21 days old, unless the asphalt pavement is contaminated with dirt, oil, or any other surface contaminant. Asphalt pavements that are clean of contaminants and less than 21 days old will only be required to be cleaned with compressed air of at least 100psi.

7. Installation Of Epoxy Markings On Newly Placed Asphalt Pavements

Asphalt pavements shall be dry, clean and free of contaminants. Newly placed asphalt pavements shall be allowed to age a minimum of 10 days prior to application of epoxy marking. Contractor shall be responsible for installing reflective temporary raised pavement markers before the roadway is opened to traffic. Raised markers shall be maintained by the Contractor until the epoxy marking is installed and then shall be removed by the Contractor after the epoxy marking is installed. This shall be incidental to the price bid for Epoxy. Reflective temporary raised pavement marker shall have 1 marker per skip, 1 marker per 20' on all solid longitudinal lane lines, and 1 marker per 100' on all solid white edge lines.

8. Chip Seal Epoxy Striping Installation
  - A. Before the chip seal is installed remove all existing markings that will not be masked by grooving out the existing marking with a groove that is 100 mils in depth.
  - B. Before the chip seal is installed, install a groove 100 mils in depth where new markings are to be placed.
  - C. Where an existing marking is to be removed but will not be replaced by another marking, the Contractor shall follow the "Obliterate Pavement Marking" specification.
  - D. Contractor is responsible for cleanup of all old marking materials that are left on the roadway.
  - E. Install reflective temporary raised pavement markers immediately after the existing marking is removed and before the roadway is opened up to traffic.

1. Raised pavement markers shall be maintained by the Contractor until the epoxy marking is installed.
  2. Temporary raised pavement markers shall be incidental to the price bid for epoxy.
  3. Install 1 marker at the beginning of each skip.
  4. Install 1 marker at the beginning and at the end on all solid longitudinal lane lines and every 20' in between.
  5. Install 1 marker at the beginning and at the end on all solid white edge lines and every 100' in between.
  6. Install 1 marker at the beginning of all striping tapers
  7. Install 1 marker at the beginning and end of all gore and cross hatched areas.
- F. Epoxy material application shall be 50 mils thick and shall be installed in the entire groove as per marking width.
- G. Epoxy markings shall not be installed within 7 days of the chip seal application or before the roadway has been sweep from excess loose chip seal aggregate.
- H. All costs associated with the above work shall be incidental to the price bid for "Paint \_\_\_ inch Epoxy" LF.

#### E. DURABLE METHACRYLATE MARKING

##### 1. EXECUTION

###### a. Pre-Work Inspection

1. The Contractor shall examine the pavement to receive the Markings and report to the project Engineer any conditions that will adversely affect performance.
2. The installation shall proceed only with authorization from the project Engineer.

###### b. Preparation

1. Asphalt and concrete pavements shall be cleaned by surface grinding/scarifiers, and then blowing off the surface prepped area with high-pressure compressed air with 185 cfm air compressor at a pressure of at least 80 psi.
2. Pavements with existing non-methacrylate markings shall remove the entire marking and shall prepare the pavement according to 3.2.1.
3. Pavements with existing methacrylate markings shall be cleaned by sandblasting or scarifying the entire surface of the marking and then blowing off the surface prepped area with high-pressure compressed air with 185 cfm air compressor at a pressure of at least 80 psi.

4. Application of Markings must be completed before water or other contamination of the pavement occurs. Upon the onset of rain, installation shall cease until the pavement is dry for 24 hours or to the satisfaction of the project Engineer.
  5. Grooved-methacrylate shall have a groove depth prepared according to the plans as directed by the project Engineer in accordance with the Manufacturer's recommendation. The groove shall be prepared to the depth specified by the plans and according the City of Fargo Standard Specification for Construction of Public Utilities along with any special instructions in the plans. After grooving, the surface must be ruffed up producing a rigid surface with a sand blaster. The surface shall be blown clean with high-pressure compressed air with 185 cfm air compressor at a pressure of at least 80 psi. The groove shall be made in a single pass dry cut using stacked diamond cutting heads mounted on a floating head with controls capable of providing uniform depth and alignment. The equipment shall be self-vacuuming, be capable of vacuuming and containing all dust contaminates from entering the air, and leave the cut groove ready for pavement marking installation. If the Engineer in the field deems that the Contractor's dust collection is not adequate then the Engineer may shut down the Contractor's operation until the Contractor has fixed the problem according the satisfaction of the Engineer. The equipment and method used shall be approved by the pavement marking manufacturer. The bottom of the groove shall have a fine corduroy finish. If a course tooth pattern is present, increase the number of blades and decrease the thickness of the spacers on the cutting head. The pavement marking shall be placed in the grooves the same day as the cut. Grooves shall be clean and dry prior to pavement marking application.
- c. Field Quality Control and Inspection
1. Contractor shall request acceptance of surface preparation and groove from the project Engineer prior to application of Markings.
  2. If required by the Engineer in the field or manufacturer due to failure of bond without any visual evidence, Bond tests shall be conducted by an independent testing company and paid for by the City of Fargo to judge the suitability of new concrete pavements. Markings shall be applied, allowed to cure, and tested for adhesion in accordance with ASTM D4541. Bond strengths of less than 250 psi without pavements failure shall result in the use of a primer prior to application of the Marking. Primers shall not be required on asphalt pavements.
  3. When a primer or underlayment is specified, the Contractor shall request acceptance from the project Engineer before application of Markings.



4. Glass beads shall be applied at the rate specified in section 2.4 to allow for proper embedment and retro reflectivity.
  5. Markings shall be unacceptable if:
    - a. Groove is not grooved to the specified depth.
    - b. Groove is not filled to the specified depth.
    - c. Profiles are missing or incorrectly shaped.
    - d. Not straight or wide enough.
    - e. Thickness is not uniform or less than specified.
    - f. Edges are not clear-cut and free from overspray.
    - g. Uncured or poorly adhered.
    - h. Material darkens or is inconsistent in color.
    - i. Glass bead dressings are not properly embedded.
    - j. Retro reflectivity is less than specified.
    - k. Color is not as specified.
    - l. Any of the Specifications for Durable Methacrylate Road Markings are not followed.
  6. All work not acceptable to the project Engineer shall be corrected before consideration of final acceptance.
  7. A Manufacturer's representative may be requested by the project Engineer for assistance during the commencement phase of the project. The representative shall confer with the Contractor and project Engineer to ensure that Markings are being installed in accordance with recommended procedures. The project Engineer shall have full authority to shut down the project if instructions by the Manufacturer's representative or the City of Fargo Specifications are not followed by the Contractor.
- d. Installation Schedule
1. Markings shall be installed following the Manufacturer's recommendations in accordance with the project plan. Marking thickness, height, width, pattern, skip length and interval shall meet the requirements of the project Engineer.

2. For unmarked pavements, a guideline shall be marked for each line prior to installation of the Marking and with the full approval of the project Engineer.
3. A test Marking shall be applied by the Contractor prior to the start of installation. This process shall be performed on roofing felt or other approved material to demonstrate the process to the acceptance of the project Engineer. Test shall be repeated until the project Engineer is satisfied to allow the project to begin. Test sample shall be allowed to cure and harden.

e. Public Safety

1. The Contractor shall provide for the safety of the public, and shall have traffic control measures in place according to the City of Fargo Standard Specification for Construction of Public Utilities, along with the MUTCD and any other specifications in the plans.
2. Fire extinguishers and related equipment as recommended by the Manufacturer and deemed necessary by the project Engineer shall be on-site at all times during the application of the Markings.
3. All Markings shall be fully cured prior to opening the area to traffic. Until cured, markings shall be protected by traffic control devices.
4. Work areas shall not be opened to traffic until fully marked and safe for driving.

f. Cleaning, Waste Disposal

1. All waste materials including surface preparation debris and Markings shall be removed from the site by the Contractor and disposed of in accordance with Federal, State and local requirements.

3.2. REMOVAL METHODS FOR EXISTING MARKINGS

A. OBLITERATE PAVEMENT MARKINGS

This bid item shall be used for the removal of existing markings in areas where the marking that is being removed will not be replaced with a new marking. Method of removal must be approved by the Engineer before any removal can be done. No carbide or diamond tip blades or wheels are allowed on removal equipment. All removal methods shall be demonstrated by the Contractor and approved by the Engineer in the field before removal is allowed.

B. ASPHALT OVERLAY STRIPING REMOVAL

All existing durable methacrylate markings on any asphalt overlay projects that will not have the surface milled prior to installation of the overlay shall remove all existing methacrylate markings on the roadway. This shall be incidental to the price bid for installing the epoxy and durable methacrylate markings.

C. EXISTING TAPE AND EPOXY

Any existing tape or epoxy that is to be replaced by new tape shall be removed, by the Contractor, before grooving or laying new tape in the groove. No additional compensation shall be given for doing this and it shall be incidental to the price bid for "Grooved Plastic Marking Film".

D. TAPE REPLACED BY EPOXY

Any existing tape that is to be replaced by epoxy shall be removed, by the Contractor, before installing the epoxy. No additional compensation shall be given for doing this and it shall be incidental to the price bid for installing the epoxy pavement marking.

3.3. GENERAL INSTALLATION NOTES

A. ARROWS

All arrows shall be installed 15' from the beginning of the turn lane furthest from the intersection. Turn lanes that are 75' or longer, will have 2 turn arrows in the lane. One turn arrow will be 15' from the beginning of the turn lane and the other will be at the midpoint of the turn lane. Turn lanes that are less than 75' in length shall have 1 turn arrow installed 15' from the beginning of the turn lane. If the placement of the arrow as described above would result in the arrow being installed in an unacceptable location (manhole, bad surface, etc.) then the placement of the arrow may move a few feet to an acceptable and good surface location.

B. PAVEMENT MARKING APPLICATION

All material shall be placed in a workmanlike manner, which shall result in a clearly defined line that has been adequately reflectorized with glass beads.

No work will be permitted on Saturday, Sunday or holidays unless the Contractor has given two working days notice, and it has been approved by the Engineer. At all locations the work may be suspended by direction of the Engineer in the field during peak traffic hours 7-8:30am, 11am-1pm, and from 4-6pm, or at any time traffic is being unduly hampered or delayed by the work in progress.

No striping operations will be permitted between sundown and sunrise without permission from the Engineer.

C. STRIPING MARKOUT

Contractor is responsible for marking out all striping that is to be installed, under the direction of the Engineer in the field.

D. PAINT

Pavement markings shall only be applied in seasonable weather when the air temperature is 50 degrees F. or higher, and a relative humidity of 85% or lower. Pavement markings shall not be applied when the wind or other conditions cause a film of dust to be deposited on the pavement surface after cleaning and before the marking material can be applied, or if in the opinion of the Engineer the pavement surface is too wet to apply markings.

The Contractor is responsible for laying out all markings in accordance with the standard drawings. All painted crosswalk lines shall be 6-inches wide. The markings shall extend the full width of the street and end at a point approximately 2-feet from the curb. All longitudinal crosswalk markings shall be 24-inches wide and spaced as shown in the standard drawing or spaced to match existing markings. All painted stop bars shall be 16-inches wide and extend from the edge of the marked centerline of the road to a point approximately 2-feet from the curb, and located as shown on the standard drawing. All painted diagonal parking lines shall be 4-inches wide white, yellow or blue, and placed in accordance with the standard drawing.

Application for the marking paint shall be such as to provide uniform film thickness throughout the coverage area. Stripe ends shall be clean cut and square, with a minimum of material beyond the cutoff.

One gallon of paint shall cover a 4-inch wide stripe for a length of 280 to 320 feet depending upon pavement surface texture. The minimum wet thickness shall be 15 mils. The paint shall not be diluted. Glass beads shall be evenly distributed over the wet paint stripe at a rate of at least 6 pounds per gallon of paint within 3 seconds of applying the paint. Beads applied to markings may be applied by hand if the application equipment is not equipped for automatic pressure dispensing. If the application rates are not within the requirements, the marking application shall be stopped until corrections are made.

E. PLASTIC PAVEMENT MARKING FILM

Pavement marking tape applied as a permanent pavement marking shall be applied according to the manufacturer's application specifications. The tape shall be butt-spliced when required to join two lengths of tape, and the tape shall be cut at both sides of the open joints or cracks in the pavement. The cut ends shall be firmly tamped in place.

Application of plastic pavement marking film, whether by contact cement or mechanical application, shall be according to the manufacturer's recommendation.

F. PREFORMED THERMOPLASTIC

Asphalt: The materials shall be applied using the propane torch method recommended by the manufacturer. The material must be able to be applied at ambient and road temperatures down to 32 degrees F. without any preheating of the pavement to a specific temperature. The pavement shall be clean, dry and free of debris. Supplier must enclose application instructions with each box/package.

Portland Concrete: The same application procedure shall be used as described above. However, a compatible primer sealer must be applied before application to assure proper adhesion.

G. EPOXY

The pavement markings shall only be applied during conditions of dry weather and on subsequently dry pavement surfaces. At the time of installation, the pavement surface temperature and the ambient temperature shall be above 50° F. The Engineer shall determine the atmospheric conditions and pavement surface conditions that produce satisfactory results.

The reflectorized pavement markings shall be placed only on properly prepared surfaces and at the widths and patterns designated.

Marking operations shall not begin until applicable surface preparation work is completed and approved by the Engineer.

The pavement markings shall be applied at a minimum uniform wet thickness of 20mils.

The application rates of each of the reflective media shall conform to the manufacturer of the marking and the manufacturer of the bead system suppliers and be approved by the Engineer in the field. The application rate shall be 3 lbs. per gallon for Particle-1 and 25 lbs. per gallon for Particle-2.

Using the applying equipment, the pavement markings shall be applied in the following manner, as a simultaneous operation:

1. The surface is air-blasted to remove dirt, residues, and if applicable, free-water.
2. The resin, mixed and heated in accordance with the manufacturer's recommendations, is hot-sprayed onto the pavement surface.
3. The application rates of each of the reflective media shall conform to the manufacturer of the marking and the manufacturer of the bead system

suppliers and be approved by the Engineer in the field. The application rate shall be 3 lbs. per gallon for Particle-1 and 25 lbs. per gallon for Particle-2.

3.4. TRAFFIC CONTROL

A. GENERAL TRAFFIC CONTROL

The Contractor shall furnish and place, without extra compensation, all necessary warning and direction signs to maintain traffic and shall provide such protection to the uncured markings as may be needed until traffic can cross them without damage.

The Contractor shall provide advance warning signs in advance of the work zone when placing stop bars and crosswalk markings. The work area shall be coned to protect workers and newly painted markings. Only a portion of each intersection approach shall be painted in one operation. Adequate space shall be provided so that one lane of traffic in each direction can be maintained. All signs and cones shall remain in place until traffic can cross newly painted markings without tracking or discoloration.

The placement of diagonal parking lines will require that the Contractor place appropriate traffic control signing and barricades far enough in advance of the work to insure that cars are not parked in the work area. The Contractor will be allowed to only prohibit parking two blocks at a time for placement of diagonal parking lines.

At all locations the work may be suspended by direction of the Engineer during peak traffic hours or at any time traffic is being unduly hampered or delayed by the work in progress.

B. LONG LINE STRIPING TRAFFIC CONTROL

The Contractor shall furnish and place without extra compensation all necessary warning and direction signs to maintain traffic and shall provide such protection to the uncured markings as may be needed until traffic can cross them without damage or tracking. When necessary, a pilot car and flagmen shall be used to provide adequate control and direction of traffic. Traffic shall be allowed to keep moving at all times and the striping equipment shall be operated in a manner that will not make it necessary for traffic to cross uncured markings. Protective devices such as "cones" shall be of an approved type that will not cause damage to the vehicle when accidentally struck.

C. ALL TRAFFIC CONTROL

The Contractor shall provide the appropriate traffic control as per the MUTCD whenever any work is being performed within any City right-of-way. All necessary traffic control will be incidental to installing the pavement markings.

3.5. ACCEPTANCE

## A. PAINT

Painted markings that are discolored, damaged by wind-blown dirt, or are ineffective at night will be rejected. Unsightly markings with uneven edge lines, over spray, poor longitudinal alignment, uneven adherence, missing portions or other objectionable faults will be rejected. The Contractor shall repair or replace all rejected markings at his expense.

Removal of unacceptable work shall be accomplished with suitable blasting or grinding equipment unless other means are authorized by the Engineer.

## B. PLASTIC PAVEMENT MARKING FILM

Plastic markings that are damaged due to improper placement, placed in the wrong locations, exhibit poor adhesion when tested in accordance to the manufacturers recommendations, have visibly moved or slid due to improper use of adhesives, display poor reflectance or color shall be properly removed and replaced by the Contractor at his expense.

## C. PREFORMED THERMOPLASTIC

Thermoplastic markings that are damaged due to improper placement, placed in the wrong locations, exhibit poor adhesion when tested in accordance to the manufacturers recommendations, have visibly moved or slid due to improper use of adhesives, display poor reflectance or color shall be properly removed and replaced by the Contractor at his expense.

## D. EPOXY

Painted markings that are discolored, damaged by wind-blown dirt, or are ineffective at night will be rejected. Unsightly markings with uneven edge lines, over spray, poor longitudinal alignment, uneven adherence, missing portions, or other objectionable faults will be rejected. The Contractor shall repair or replace all rejected markings at his expense.

Removal of unacceptable work shall be accomplished with suitable blasting or grinding equipment unless other means are authorized by the Engineer.

E. DURABLE METHACRYLATE MARKINGS

Painted markings that are discolored, damaged by wind-blown dirt, or are ineffective at night will be rejected. Unsightly markings with uneven edge lines, over spray, poor longitudinal alignment, uneven adherence, missing portions, or other objectionable faults will be rejected. The Contractor shall repair or replace all rejected markings at his expense.

Removal of unacceptable work shall be accomplished with suitable blasting or grinding equipment unless other means are authorized by the Engineer.



**PART 4  
WARRANTY, MEASUREMENT & PAYMENT**

*4.1. WARRANTY*

The Contractor shall be responsible for enforcing the manufacturer’s warranty on markings.

*4.2. MEASUREMENT AND PAYMENT*

Only the installed portion of broken lines will be measured for payment by the linear foot.

Messages, arrows, and island tip painting will be paid by the square foot.

Obliterate Pavement will be paid for by the square foot.

Pavement Marking Masking will be paid for by the square foot.

All 4”, 6”, 8”, 16”, & 24” markings will be paid for by the linear foot.

Pavement markings will be measured and paid according to the units as noted on the bid sheet.

A reduction in pay for long line striping shall be made for reduced thickness and/or width. Width shall be computed by random measuring. Thickness shall be computed by the following formula:

$$\text{Mils Thickness} = \frac{\text{Gallons} \times 231}{\text{Linear Length} \times \text{Striping Width}}$$

The Contractor shall provide the Engineer with the linear feet of 4-inch stripe and gallons of paint used at the end of each days striping.

Where yield computations show a deficiency in material usage of not more than 10 percent, the City may require satisfactory repair or may accept the work at a reduced unit price, which is in direct proportion of the percent of the deficiency. Where the deficiency in material usage exceeds 10 percent the City may require restriping to the satisfaction of the Engineer.

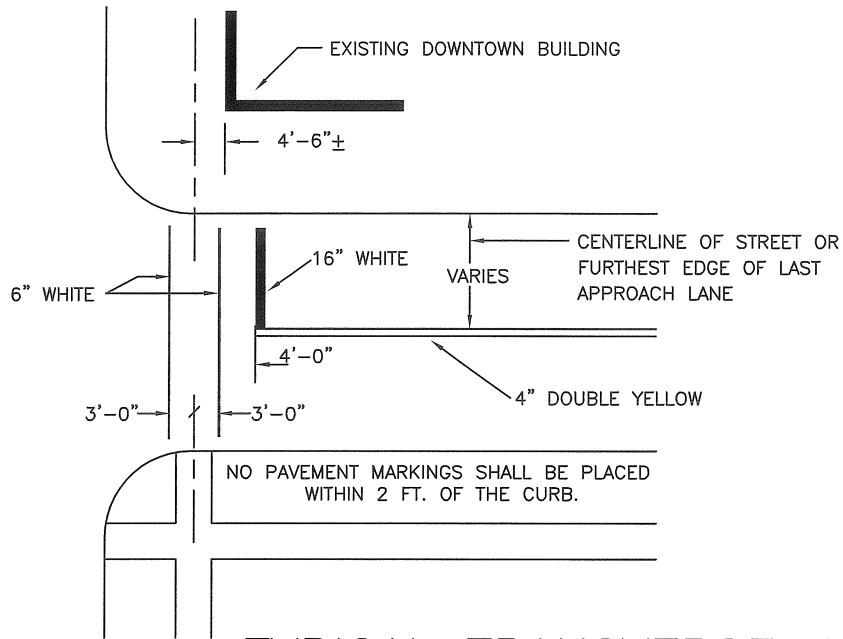

TYPICAL TRANSVERSE CROSSWALK

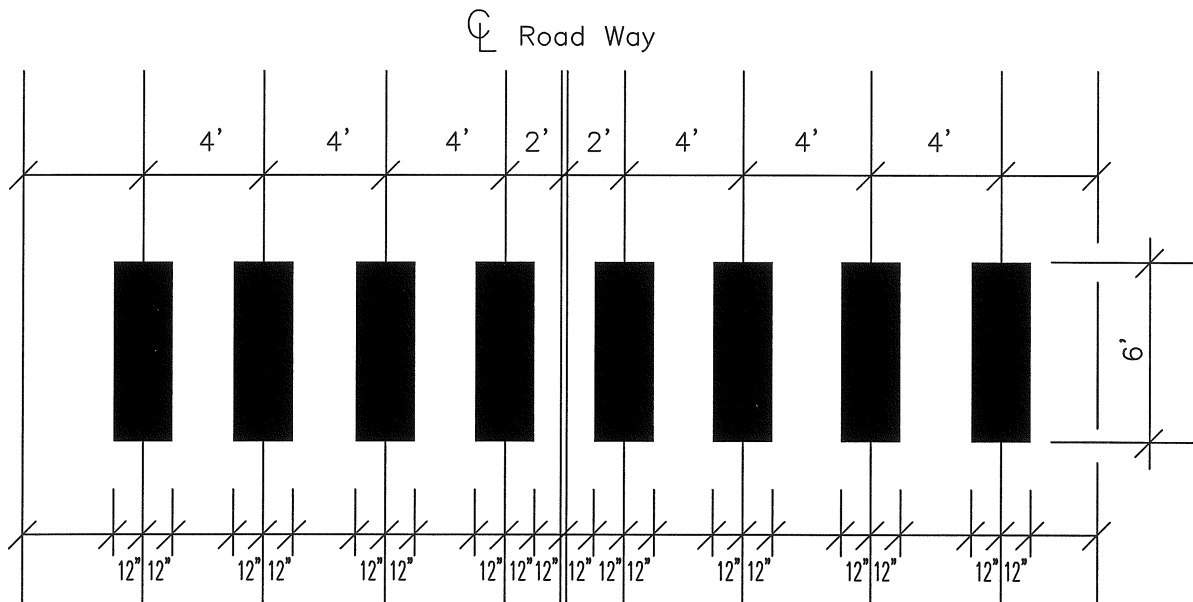

NOTE: Max. of 24" spacing between blocks.

TYPICAL LONGITUDINAL CROSSWALK

SECTION NO. 4000	DRAWING NO. 5.1
REV.D. 2012	
<b>TYPICAL CROSSWALK</b>	
CITY OF FARGO ENGINEERING DEPARTMENT	
APPROVED: <i>BED</i>	DATE: <i>2-21-2012</i>

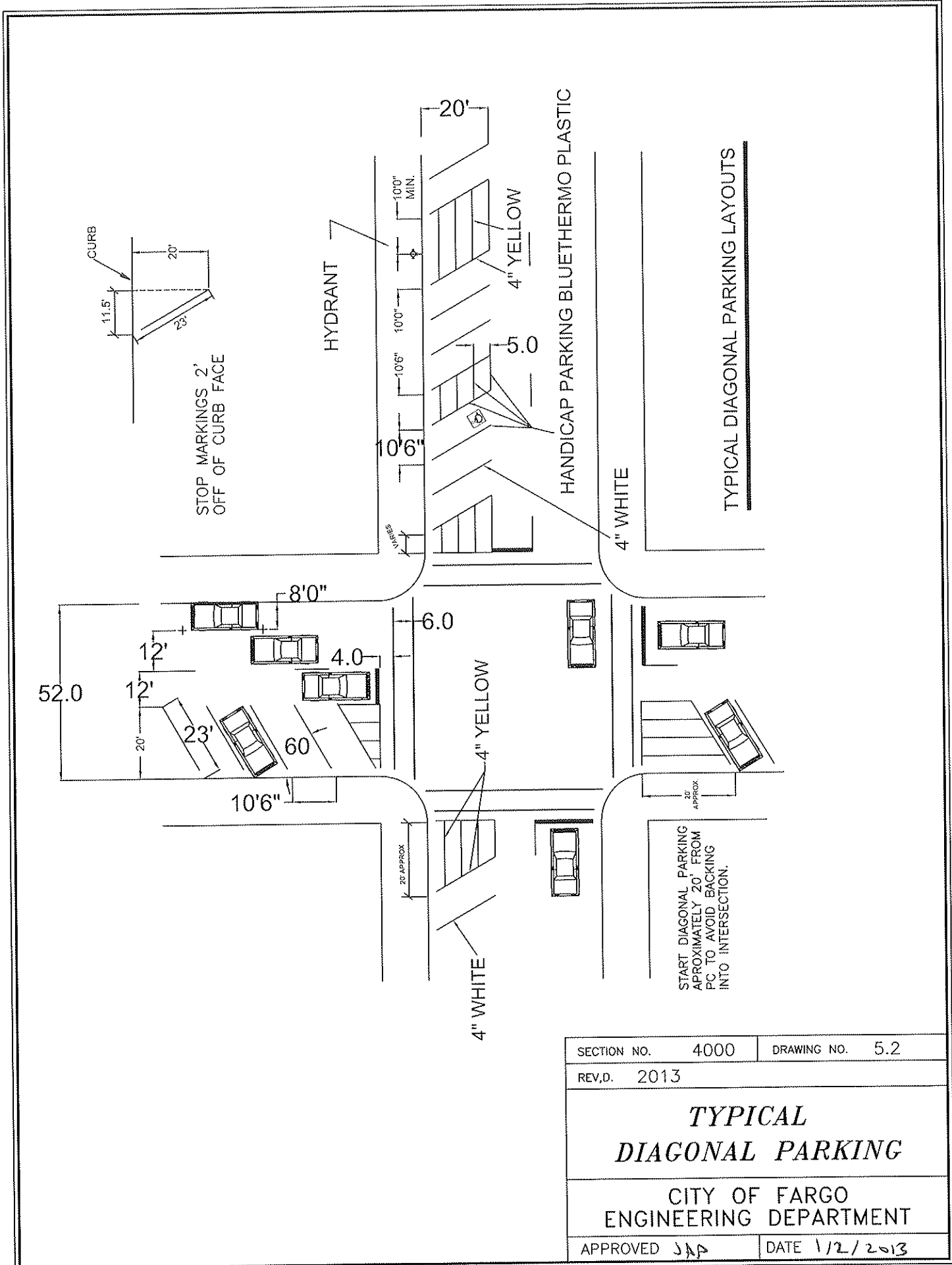

SECTION NO.	4000	DRAWING NO.	5.2
REV.D.	2013		
<b>TYPICAL DIAGONAL PARKING</b>			
CITY OF FARGO ENGINEERING DEPARTMENT			
APPROVED	JAP	DATE	1/2/2013

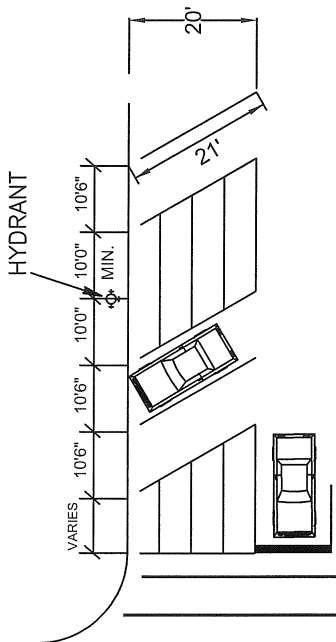

UNDER 9'6" - CROSS HATCH THE REMAINING AREA

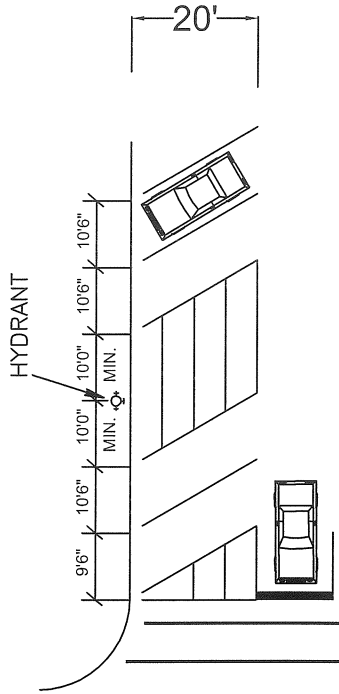

MINIMUM 9'6" PARKING SPACE

NOTES:

- 1) WHEN AREA FOR PARKING IS LESS THAN 10'6" MINIMUM PARKING SPACE WIDTH IS 9'6".
- 2) SKIPS & DBL. YELLOW SHALL START EVEN WITH THE FRONT EDGE OF THE STOP BAR.

- 3) STOP BARS SHALL BE PLACED UP TO THE SIDE EDGE OF THE SKIP OR DBL. YELLOW.
- 4) ALL LAYOUTS WILL START AT THE PC OR 4 FT. FROM THE CROSS-WALK, WHICH EVER IS GREATER. WORK SHALL PROCEED IN THE DIRECTION OF VEHICLE TRAVEL.

STOP MARKINGS 2'  
OFF OF CURB FACE

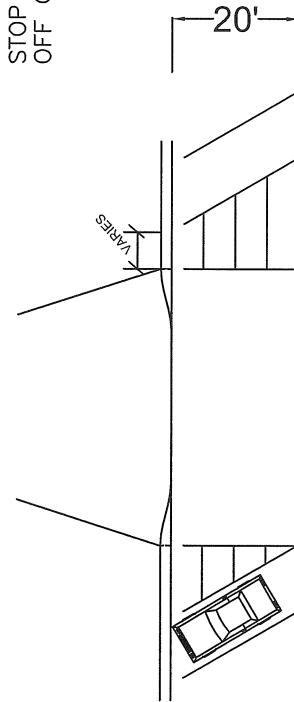

DRIVEWAYS OR ALLEYS

START MEASUREMENTS AT THE BEGINNING OF THE PC - NOT EVEN WITH THE DRIVEWAY

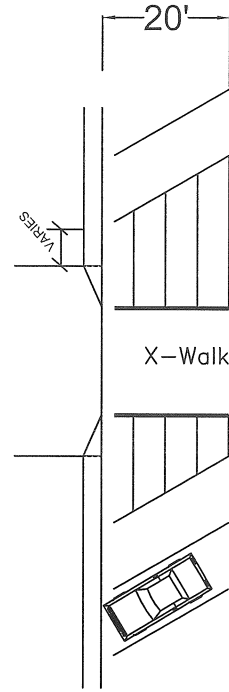

MIDBLOCK PED CROSSING

SECTION NO.	4000	DRAWING NO.	5.3
REV,D.	2012		
<b>TYPICAL DIAGONAL PARKING</b>			
CITY OF FARGO ENGINEERING DEPARTMENT			
APPROVED	BEO	DATE	2-21-2012

# MINIMUM STREET WIDTHS WITH DIAGONAL PARKING

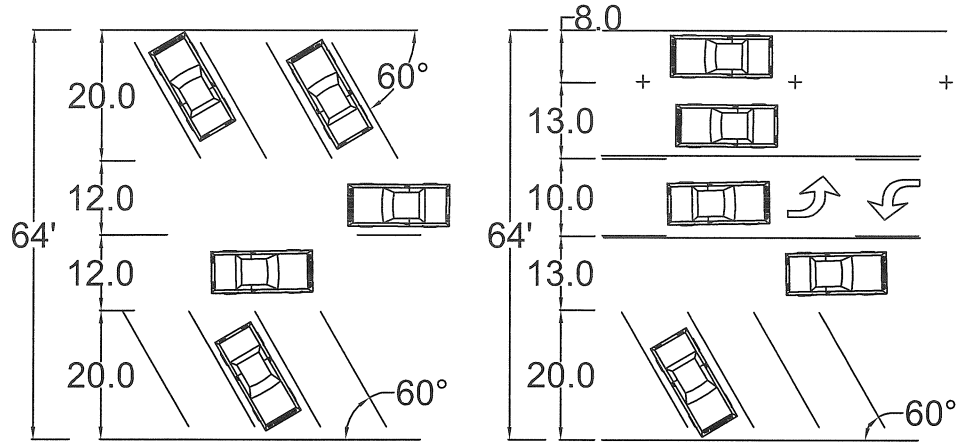

STOP MARKINGS 2'  
OFF OF CURB FACE

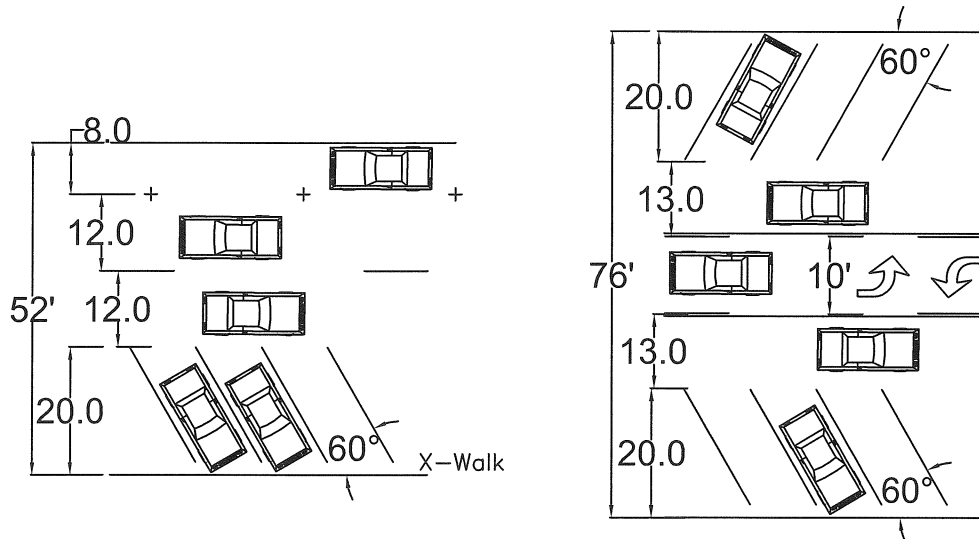

SECTION NO. 4000	DRAWING NO. 5.4
REV.D. 2012	
<b>TYPICAL DIAGONAL PARKING</b>	
CITY OF FARGO ENGINEERING DEPARTMENT	
APPROVED <i>BEO</i>	DATE <i>2-21-2012</i>

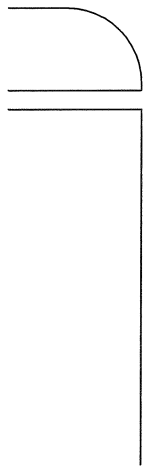

4" DOUBLE YELLOW

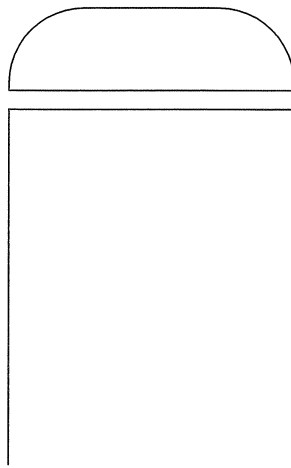

4" YELLOW

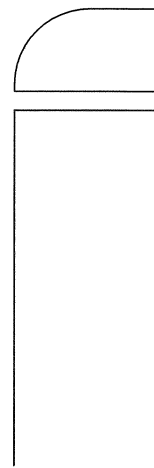

TYPICAL DOUBLE YELLOW-NO STOP BAR  
STOP BEFORE CROSSWALK

TYPICAL SKIPS-NO STOP BAR  
STOP BEFORE CROSSWALK

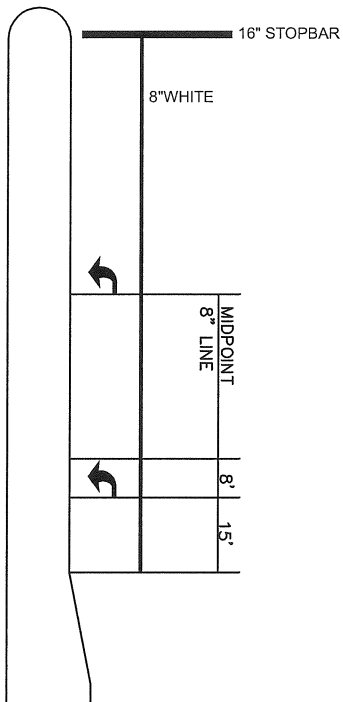

TYPICAL TURNBAY-NO CROSSWALK  
WITH STOP BAR

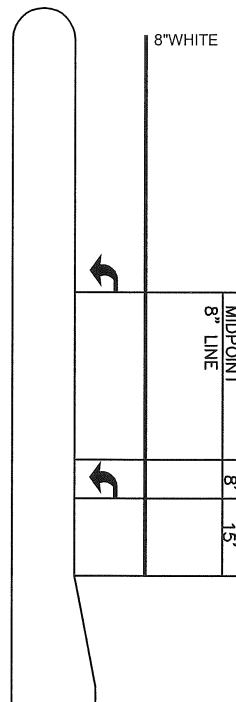

TYPICAL TURNBAY-NO STOP BAR  
STOP AT END OF ISLAND

SECTION NO.	4000	DRAWING NO.	5.5
-------------	------	-------------	-----

REV.D. 2012

**STRIPING  
DETAIL**

CITY OF FARGO  
ENGINEERING DEPARTMENT

APPROVED *BEO* DATE *2-21-2012*

CORRECT MARKING PLACEMENT

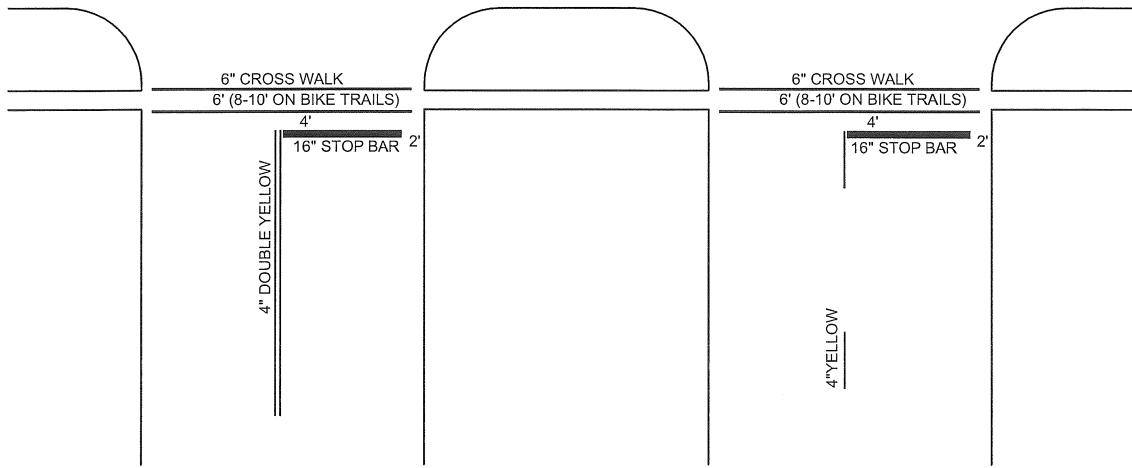

TYPICAL DOUBLE YELLOW WITH STOP BAR

TYPICAL SKIPS WITH STOP BAR

INCORRECT MARKING PLACEMENT

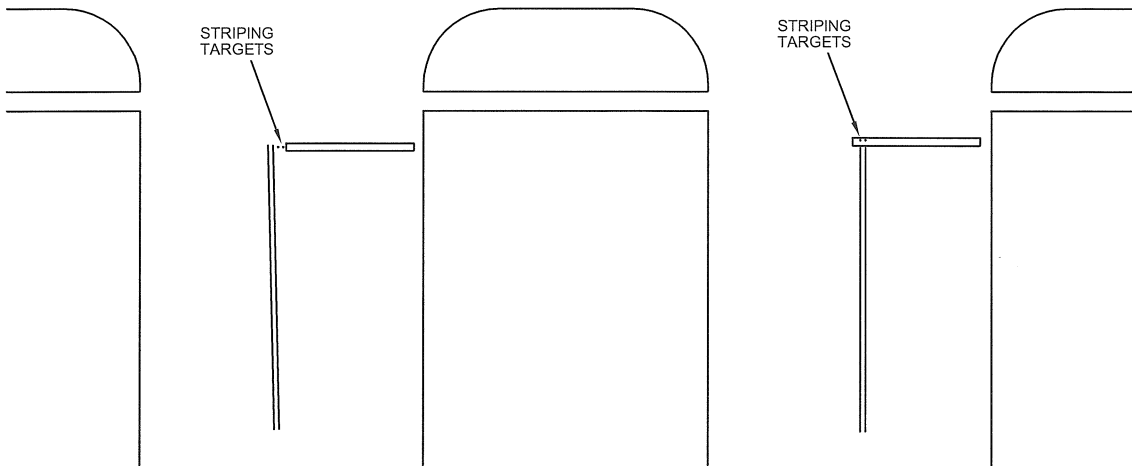

TYPICAL DOUBLE YELLOW-W/STOP BAR  
STOP BAR RIGHT-DOUBLE YELLOW WRONG\*

TYPICAL DOUBLE YELLOW-W/STOP BAR  
DOUBLE YELLOW RIGHT-STOPBAR WRONG\*

\*NOTE: IF LONGLINE OR STOP BAR ARE  
INSTALLED INCORRECTLY, THE REMAINING  
MARKS SHALL BE INSTALLED CORRECTLY  
REGARDLESS OF THE MISPLACED MARKING.

\*NOTE: NEW MARKINGS SHALL NOT BE  
PLACED OVER EXISTING MARKINGS WHICH  
ARE INCORRECT, BUT SHALL BE PUT DOWN  
CORRECTLY.

SECTION NO.	4000	DRAWING NO.	5.6
REV,D.	2012		
<b>STRIPING DETAIL</b>			
CITY OF FARGO ENGINEERING DEPARTMENT			
APPROVED	BED	DATE	2-21-2012



R7-8  
12"x18"



R7-8/P  
12"x12"



R7-8  
12"x18"



R7-8/P  
12"x12"



R7-8a  
12"x6"

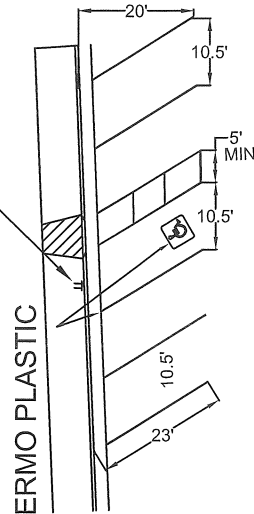

STANDARD ACCESS

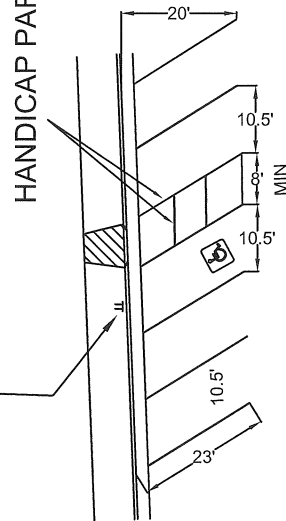

VAN ACCESSIBLE

SECTION NO. 4000	DRAWING NO. 5.7
REV.D. 2012	
<b>TYPICAL HANDICAP PARKING</b>	
CITY OF FARGO ENGINEERING DEPARTMENT	
APPROVED <i>BED</i>	DATE <i>2-21-2012</i>



T:\Engineering\Traffic\Striping\Files & Details\Standard Drawings\Section 4000 Drawings5\_8.dwg



12 SF

ONLY

22 SF



12 SF

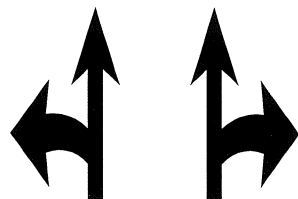

27 SF



16 SF

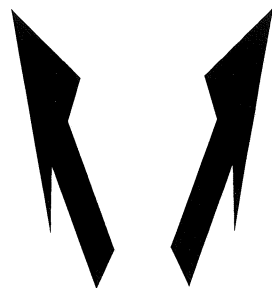

42 SF

MUST

27.06 SF

AHEAD

29 SF

MERGE

35.94 SF

ENDS

27.10 SF

STOP

23.5 SF

SHIFT

22.58 SF

MPH

22.44 SF

25

11 SF

LANE

23 SF

LEFT

20.5 SF



24 SF



6.5 SF



20 SF



RR  
70 SF

20 SF  
XING  
SCHOOL  
33 SF

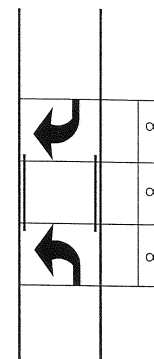

ARROW SPACING

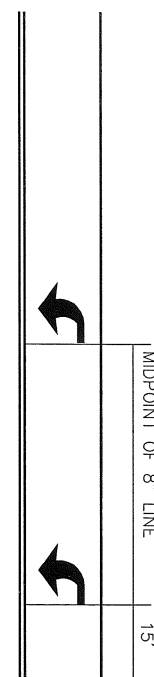

INSTALL FLEXIBLE DELINEATORS. LOCATIONS WILL BE MARKED BY THE ENGINEER IN THE FIELD. SHALL BE PAID AS FLEXIBLE DELINEATOR. 36" IN HEIGHT

Yellow or White 3M H.I. Reflective Sheeting.

Yellow or White Flexi-Guide 300 Polyurethane.

Island Tip Delineators Shall Be Affixed To Island Tip By Utilizing Two Concrete Lag Bolts.

FLEXIBLE DELINEATORS

**ISLAND TIP PAINTING:**  
ALL ISLAND TIPS TO BE PAINTED SHALL BE CLEANED OF ALL CONTAMINATION, INCLUDING OIL, DIRT, GREASE, AND CURING COMPOUND. THIS PREPARATION PROCESS CAN BE ACCOMPLISHED BY SANDBLASTING, WATERBLASTING, OR ANY OTHER NON-DESTRUCTIVE PROCESS THAT IS APPROVED BY THE ENGINEER. CURB/ISLAND TIPS SHALL BE PAINTED WITH A MINIMUM UNIFORM 15 MIL THICK YELLOW EPOXY. REFLECTIVE GLASS SPHERES SHALL BE APPLIED TO THE ENTIRE SURFACE OF THE PAINTED AREA. ISLAND TIP PAINTING SHALL BE PAID FOR BY THE SQUARE FOOT AS EPOXY PVMT MK MESSAGE. SUFFICIENT PREPARATION SHALL BE DONE TO ASSURE EPOXY ADHERES TO THE SURFACE. IF THE EPOXY SHOWS SIGNS OF PEELING WITHIN 1 YEAR FROM THE APPLICATION DATE, THE CONTRACTOR SHALL BE REQUIRED TO REPREP AND REPAINT WITH EPOXY AT HIS OWN EXPENSE.



16 SF

SECTION NO. 4000	DRAWING NO. 5.8
REV.D. 2012	
<b>MISCELLANEOUS MARKINGS &amp; DELINEATION</b>	
CITY OF FARGO ENGINEERING DEPARTMENT	
APPROVED <i>BED</i>	DATE <i>2-21-2012</i>

**CITY OF FARGO SPECIFICATIONS  
TRAFFIC CONTROL**

**PART 1  
DESCRIPTION OF WORK**

The work to be done under this section of the Specifications and the accompanying plans consists of all labor, material, accessories, and equipment necessary to furnish, install and maintain the specified traffic control devices at the designated locations.

**PART 2**  
**MATERIALS**

All devices and methods of traffic control shall conform to the latest edition of the Manual of Uniform Traffic Control Devices, published by FHWA.

MUTCD: [http://mutcd.fhwa.dot.gov/hm/2009/html\\_index.htm](http://mutcd.fhwa.dot.gov/hm/2009/html_index.htm)

MUTCD, Traffic Control section: [http://mutcd.fhwa.dot.gov/hm/2009/part6/part6\\_toc.htm](http://mutcd.fhwa.dot.gov/hm/2009/part6/part6_toc.htm)

MUTCD Pedestrian Traffic Control Guidelines: <http://mutcd.fhwa.dot.gov/hm/2009/part6/part6d.htm>

ADA Standards for Accessible Design: <http://www.ada.gov/>

**PART 3**  
**CONSTRUCTION**

3.1. GENERAL

The Contractor is responsible for signing, barricades and traffic control devices to protect the traveling public and direct them around the construction site. Traffic control devices shall be installed at the inception of the construction process. These devices shall be maintained for the duration of the project. They shall remain in place only as long as they are needed and shall be immediately removed thereafter. The Contractor shall provide any additional personnel as needed to direct the traveling public around the work zone. A work zone consists of an area with construction, maintenance, or utility work activities. The work zone extends from the first sign to the last device on any roadway segment.

3.2. PEDESTRIAN AND BICYCLE SAFETY

The Contractor shall not create a hazardous condition or block the movement of pedestrian or bicycle traffic without an appropriate ADA compliant alternate route and closure established. The Contractor shall provide for pedestrian and bicycle traffic by phasing construction operations and/or by providing alternative pedestrian and bicyclist access through or adjacent to construction areas. Proper advance notice signage with reasonable detours shall be installed and maintained through all phases of construction. Access to pedestrian and bicycle devices at traffic signals shall be maintained at all times. At no time shall pedestrians be diverted into a portion of the street used for vehicular traffic or on to private property unless proper barriers, delineations, and adequate signage is in place.

The costs associated with pedestrian access shall be included in the traffic control bid item.

MUTCD Pedestrian Traffic Control Guidelines: <http://mutcd.fhwa.dot.gov/htm/2009/part6/part6d.htm>

ADA Standards for Accessible Design: <http://www.ada.gov/>

3.3. LOCAL TRAFFIC CONTROL

The Contractor is responsible for signing and barricading entrance points to the construction site to restrict access to the general public and maintain their safety. This category of traffic control is generally used for sites with limited outside traffic and limited exposure to the traveling public.

### 3.4. TRAFFIC CONTROL - MINOR

#### *3.4.1. SHORT TERM STATIONARY AND MOBILE OPERATIONS*

This classification is characterized by short term installations that are not used or left in place at night.

The Contractor shall provide flaggers and have them stationed near the work zone to assist the general public and construction vehicles in and around the work zone. All flagging activities and equipment shall conform to the standards set forth in the latest edition of the Manual of Uniform Traffic Control Devices, published by FHWA. The cost of flaggers shall be included in the contract unit price for Traffic Control.

### 3.5. TRAFFIC CONTROL – TYPE 1

This level of traffic control requires that the Contractor provide a watch person to monitor and document the site on a daily basis.

The Contractor shall provide flaggers in controlled access areas of the work zone that has work occurring in the normal traveled lane. All flagging activities and equipment shall conform to the standards set forth in the latest edition of the Manual of Uniform Traffic Control Devices, published by FHWA. The cost of flaggers shall be included in the contract unit price for Traffic Control.

If the Contractor does not make a reasonable effort to correct any deficiency in a timely manner, work on the entire project will be shut down for a minimum of 24 hours until the problem is corrected. In addition, the Contractor shall provide a plan to the Engineer as to how future problems will be avoided prior to resuming construction activities.

#### *3.5.1. Watch Persons*

Watch persons shall be provided to patrol the project to assure that the traffic control devices are properly placed in accordance with the traffic control plans and standards. The project shall be patrolled daily at least once during daylight before 10:00 A.M. and at least once after the Contractor has shut down for the day or after 6:00 P.M. on weekends and days when no work is in progress.

The Contractor shall provide written documentation to the Engineer of the watch person's hours and activities. (See attached "Traffic Control Devices Daily Checklist" form.)

The Contractor shall immediately assist the watch person, whenever needed, to correct conditions that cause erratic traffic movement, unexpected braking, etc., and erect, repair, replace, or relocate the required traffic control devices. Emergency assistance shall be provided to motorists, when needed, due to roadway conditions. Upon written request to the Engineer, suspension of watch person service may be permitted during periods of authorized suspension or after substantial completion of work, provided the job site is in safe condition.

3.5.1.A. Qualifications

The watch person shall:

- 1) Be familiar with the requirements of the City of Fargo traffic control plans and Specifications for the particular job in which he/she is assigned.
- 2) Have completed a NDDOT-approved Traffic Control Technician Course.
- 3) The watch person must submit their name and phone number to the project Engineer prior to the start of the project. The watch person will be required to submit the "Traffic Control Devices Daily Checklist" forms to the project Engineer on a weekly basis.

3.6. TRAFFIC CONTROL – TYPE 2

This level of traffic control requires that the Contractor provide a traffic control supervisor in addition to a watch person to monitor and document the site. Flagging and watch person requirements shall be per Traffic Control – Type 1 above.

Proposed signing shall be submitted to the Engineer for approval prior to the closing of a particular street.

The Contractor will be subject to an hourly charge for failure to maintain the traffic control devices and enclosure as set forth in these Specifications. If the Contractor does not correct any deficiencies within one (1) hour of being notified, the Contractor will be assessed an initial \$900 fee and an additional \$100.00 per hour for each hour or any portion thereof which the Engineer determines that the Contractor has not complied. However, no charge will be made if the deficiency is corrected within (1) hour of notification.

### *3.6.1. Traffic Control Supervisor*

The Contractor shall designate a qualified traffic control supervisor. This supervisor shall be in addition to the watch person specified in section (2) below. If this traffic control supervisor becomes unavailable on the project, the Contractor shall designate a qualified replacement supervisor.

#### 3.6.1.A. Qualifications

The traffic control supervisor shall:

- 1) Be familiar with the requirements of the City of Fargo traffic control plans and Specifications.
- 2) Have completed a NDDOT-approved Traffic Control Supervisor Course and furnish proof thereof at the preconstruction meeting.
- 3) Have a total of at least 12 months field experience with traffic control plans, layouts and maintenance.
- 4) Be competent to supervise personnel in traffic control operations.

#### 3.6.1.B. Duties

The traffic control supervisor shall:

- 1) Provide traffic control as required by plans, Specifications, MUTCD, or as directed by the Engineer.

- 2) Supervise the installation, operations, inspection, maintenance, and removal of the traffic control system.
- 3) Correct traffic control conditions that cause erratic vehicle movements, unexpected braking, etc.
- 4) Propose changes to improve traffic flow through the work zone.
- 5) Be accessible to the job site within one hour of notification and be “on call” on a 24-hour basis.
- 6) Provide the Engineer with documentation of all traffic control activities required on item (2) above.
- 7) Function as watch person in his/her absence.

#### 3.6.2. *Watch Persons*

Watch persons shall be provided to patrol the project to assure that the traffic control devices are properly placed in accordance with the traffic control plans and standards. The project shall be patrolled daily at least once during daylight before 10 A.M. and at least once during darkness, minimum 30 minutes after sunset, including weekends and days when no work is in progress.

The traffic control Contractor shall provide written documentation to the Engineer on a weekly basis of the watch person’s hours and activities. (See attached “Traffic Control Devices Daily Checklist” form.) Progressive estimates will not be processed unless the documentation is submitted and up to date.

The Contractor shall immediately assist the watch person, whenever needed, to correct conditions that cause erratic traffic movement, unexpected braking, etc., and erect, repair, replace, or relocate the required traffic control devices. Emergency assistance shall be provided to motorists, when needed, due to roadway conditions. Upon written request to the Engineer, suspension of watch person service may be permitted during periods of authorized suspension or after substantial completion of the work, provided the job site is in safe condition.



3.6.2.A. Qualifications

*The watch person shall:*

- 1) Be familiar with the requirements of the City of Fargo traffic control plans and specification for the particular job in which he/she is assigned.
- 2) Have completed a NDDOT-approved Traffic Control Technician Course.
- 3) The watch person must submit their name and phone number to the project Engineer prior to the start of the project. The watch person will be required to submit the “Traffic Control Devices Daily Checklist” forms to the Project Engineer on a weekly basis.

The Contractor shall designate the construction foreman or alternate contact person who will be responsible for the construction activities, which include the activities of all the subcontractors.

The City will inform the contact person anytime a deficiency is noticed in the traffic control. The contact person shall be required to make sure the necessary corrective actions are put in place, which includes the deficiencies caused by the subcontractors.

The City will notify the prime Contractor when the charges begin. The prime Contractor shall be responsible for notifying the City when appropriate corrective actions have been carried out, in order to suspend the accumulation of any further fees.

The Contractor shall note a traffic control Contractor will be required to perform the duties of traffic control supervisor and watch person. The prime Contractor will NOT be allowed to perform these duties.

**PART 4**  
**PAYMENT**

4.1. LOCAL TRAFFIC CONTROL

Incidental to contract.

4.2. TRAFFIC CONTROL - MINOR

This bid item shall be a lump sum bid item and shall include all signing for traffic and pedestrian control (including detour routes), barricades, channelizing devices, temporary striping, changeable message boards, etc.

4.3. TRAFFIC CONTROL – TYPE 1

This bid item shall be a lump sum bid item and shall include all signing for traffic and pedestrian control (including detour routes), barricades, channelizing devices, temporary striping, changeable message boards, etc.

4.4. TRAFFIC CONTROL – TYPE 2

This bid item shall be a lump sum bid item and shall include all signing for traffic and pedestrian control (including detour routes), barricades, channelizing devices, temporary striping, changeable message boards, etc.

# Typical Application Legend

Table 1

⊙	Channelizing Device – Barrel
○	Channelizing Device – Tube
└→	Direction of temporary traffic detour
→	Direction of traffic
⊠	Flagger
▨	Longitudinal channelizing device
┌	sign (shown facing left)
⊕	Surveyor
▩	Type 3 barricade
▨	Work space

Table 2

Road Type	Distance Between Signs**		
	A	B	C
Urban (low speed)*	100 feet	100 feet	100 feet
Urban (high speed)*	350 feet	350 feet	350 feet
Rural	500 feet	500 feet	500 feet
Expressway / Freeway	1,000 feet	1,500 feet	2,640 feet

\* Speed category to be determined by highway agency  
 \*\* The column headings A, B, and C are the dimensions shown in Figures 6H-1 through 6H-46. The A dimension is the distance from the transition or point of restriction to the first sign. The B dimension is the distance between the first and second signs. The C dimension is the distance between the second and third signs. (The 'first sign' is the sign in a three-sign series that is closest to the TTC zone. The 'third sign' is the sign that is furthest upstream from the TTC zone.)

Table 3

Speed (S)	Taper Length (L) in feet
40 mph or less	$L = \frac{WS^2}{60}$
45 mph or more	$L = WS$

Where: L = taper length in feet  
 W = width of offset in feet  
 S = posted speed limit, or off-peak 85th-percentile speed prior to work starting, or the anticipated operating speed in mph

SECTION NO. 4100	DRAWING NO. 5.1
REV.D.	
<i>Traffic Control Typical Applications - Legend -</i>	
CITY OF FARGO ENGINEERING DEPARTMENT	
APPROVED JAA	DATE 1/2/2013

# TA-3 Work on the Shoulders

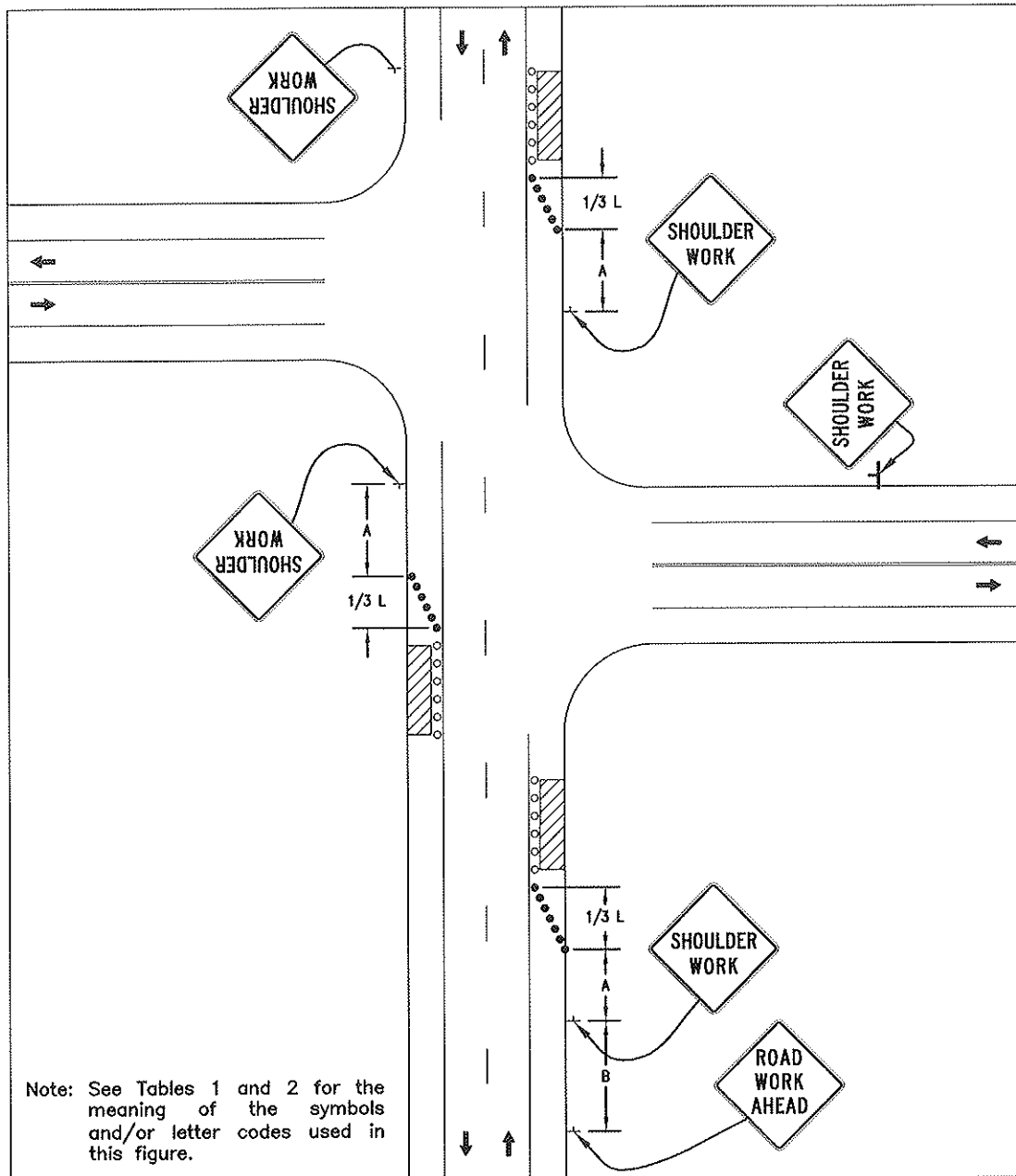

**Guidance:**

1. A SHOULDER WORK sign should be placed on the left side of the roadway for a divided or one-way street only if the left shoulder is affected.

**Option:**

2. The Workers symbol signs may be used instead of SHOULDER WORK signs.
3. The SHOULDER WORK AHEAD sign on an intersecting roadway may be omitted where drivers emerging from that roadway will encounter another advance warning sign prior to this activity area.
4. For short duration operations of 60 minutes or less, all signs and channelizing devices may be eliminated if a vehicle with activated high-intensity rotating, flashing, oscillating, or strobe lights is used.
5. Vehicle hazard warning signals may be used to supplement high-intensity rotating, flashing, oscillating, or strobe lights.

**Standard:**

6. Vehicle hazard warning signals shall not be used instead of the vehicle's high-intensity rotating, flashing, oscillating, or strobe lights.
7. When paved shoulders having a width of 8 feet or more are closed, at least one advance warning sign shall be used. In addition, channelizing devices shall be used to close the shoulder in advance to delineate the beginning of the work space and direct vehicular traffic to remain within the traveled way.

SECTION NO. 4100	DRAWING NO. 5.2
REV.D.	
<i>Traffic Control Typical Applications</i>	
- TA-3 -	
CITY OF FARGO ENGINEERING DEPARTMENT	
APPROVED JAD	DATE 1/2/2013

# TA-6 Shoulder Work with Minor Encroachment

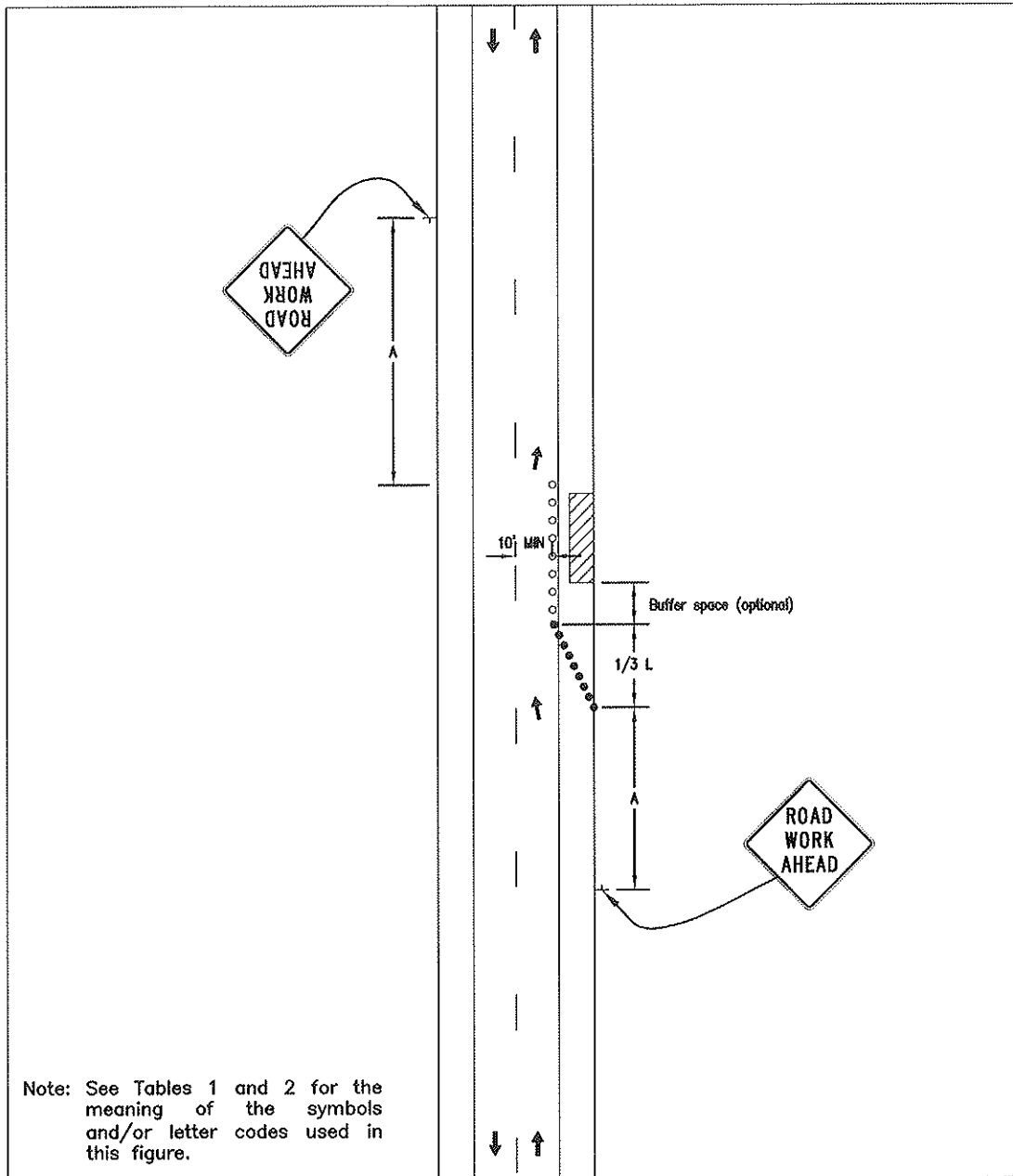

### Guidance:

1. All lanes should be a minimum of 10 feet in width as measured to the near face of the channelizing devices.
2. The treatment shown should be used on a minor road having low speeds. For higher-speed traffic conditions, a lane closure should be used.

### Option:

3. For short-term use on low-volume, low-speed roadways with vehicular traffic that does not include longer and wider heavy commercial vehicles, a minimum lane width of 9 feet may be used.
4. Where the opposite shoulder is suitable for carrying vehicular traffic and of adequate width, lanes may be shifted by use of closely-spaced channelizing devices, provided that the minimum lane width of 10 feet is maintained.
5. Additional advance warning may be appropriate, such as a ROAD NARROWS sign.
6. Temporary traffic barriers may be used along the work space.
7. The shadow vehicle may be omitted if a taper and channelizing devices are used.
8. A truck-mounted attenuator may be used on the shadow vehicle.
9. For short-duration work, the taper and channelizing devices may be omitted if a shadow vehicle with activated high-intensity rotating, flashing, oscillating, or strobe lights is used.
10. Vehicle hazard warning signals may be used to supplement high-intensity rotating, flashing, oscillating, or strobe lights.

### Standard:

11. Vehicle-mounted signs shall be mounted in a manner such that they are not obscured by equipment or supplies. Sign legends on vehicle-mounted signs shall be covered or turned from view when work is not in progress.
12. Shadow and work vehicles shall display high-intensity rotating, flashing, oscillating, or strobe lights.
13. Vehicle hazard warning signals shall not be used instead of the vehicle's high-intensity rotating, flashing, oscillating, or strobe lights.

SECTION NO. 4100	DRAWING NO. 5.3
REV.D.	
<i>Traffic Control Typical Applications</i> - TA-6 -	
CITY OF FARGO ENGINEERING DEPARTMENT	
APPROVED J A J	DATE 1/2/2013

# TA-10 Lane Closure on a Two-Lane Road Using Flaggers

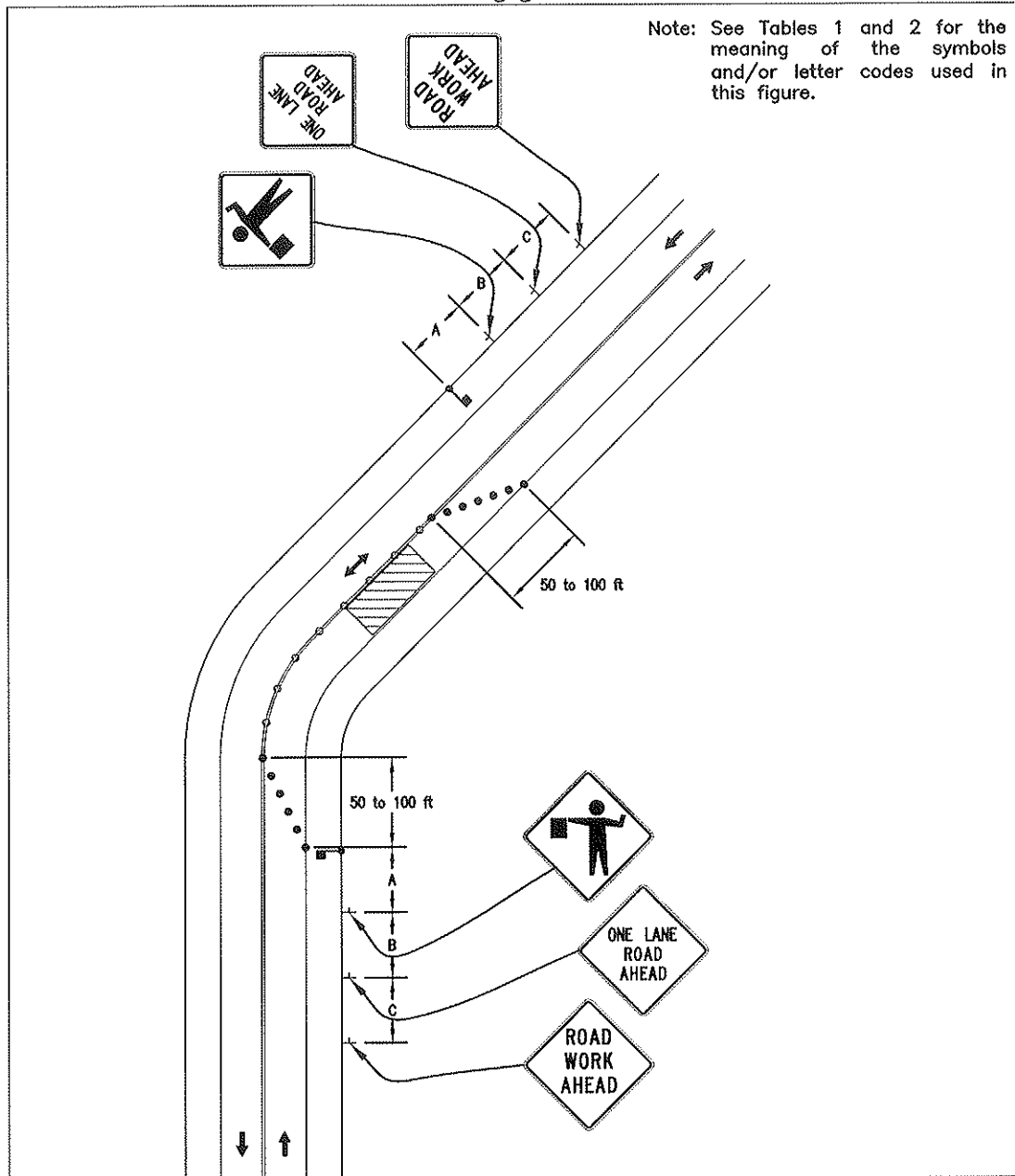

## Option:

1. For low-volume situations with short work zones on straight roadways where the flagger is visible to road users approaching from both directions, a single flagger, positioned to be visible to road users approaching from both directions, may be used (see Chapter 6E).
2. The ROAD WORK AHEAD and the END ROAD WORK signs may be omitted for short-duration operations.
3. Flashing warning lights and/or flags may be used to call attention to the advance warning signs. A BE PREPARED TO STOP sign may be added to the sign series.

## Guidance:

4. The buffer space should be extended so that the two-way traffic taper is placed before a horizontal (or crest vertical) curve to provide adequate sight distance for the flagger and a queue of stopped vehicles.

## Standard:

5. At night, flagger stations shall be illuminated, except in emergencies.

## Guidance:

6. When used, the BE PREPARED TO STOP sign should be located between the Flagger sign and the ONE LANE ROAD sign.
7. When a grade crossing exists within or upstream of the transition area and it is anticipated that queues resulting from the lane closure might extend through the grade crossing, the TTC zone should be extended so that the transition area precedes the grade crossing.
8. When a grade crossing equipped with active warning devices exists within the activity area, provisions should be made for keeping flaggers informed as to the activation status of these warning devices.

9. When a grade crossing exists within the activity area, drivers operating on the left-hand side of the normal center line should be provided with comparable warning devices as for drivers operating on the right-hand side of the normal center line.

10. Early coordination with the railroad company or light rail transit agency should occur before work starts.

## Option:

11. A flagger or a uniformed law enforcement officer may be used at the grade crossing to minimize the probability that vehicles are stopped within 15 feet of the grade crossing, measured from both sides of the outside rails.

SECTION NO.	4100	DRAWING NO.	5.4
REV.D.			
<i>Traffic Control Typical Applications</i>			
- TA-10 -			
CITY OF FARGO ENGINEERING DEPARTMENT			
APPROVED	JAA	DATE	1/2/2013

# TA-11 Lane Closure on a Two-Lane Road with Low Traffic Volumes

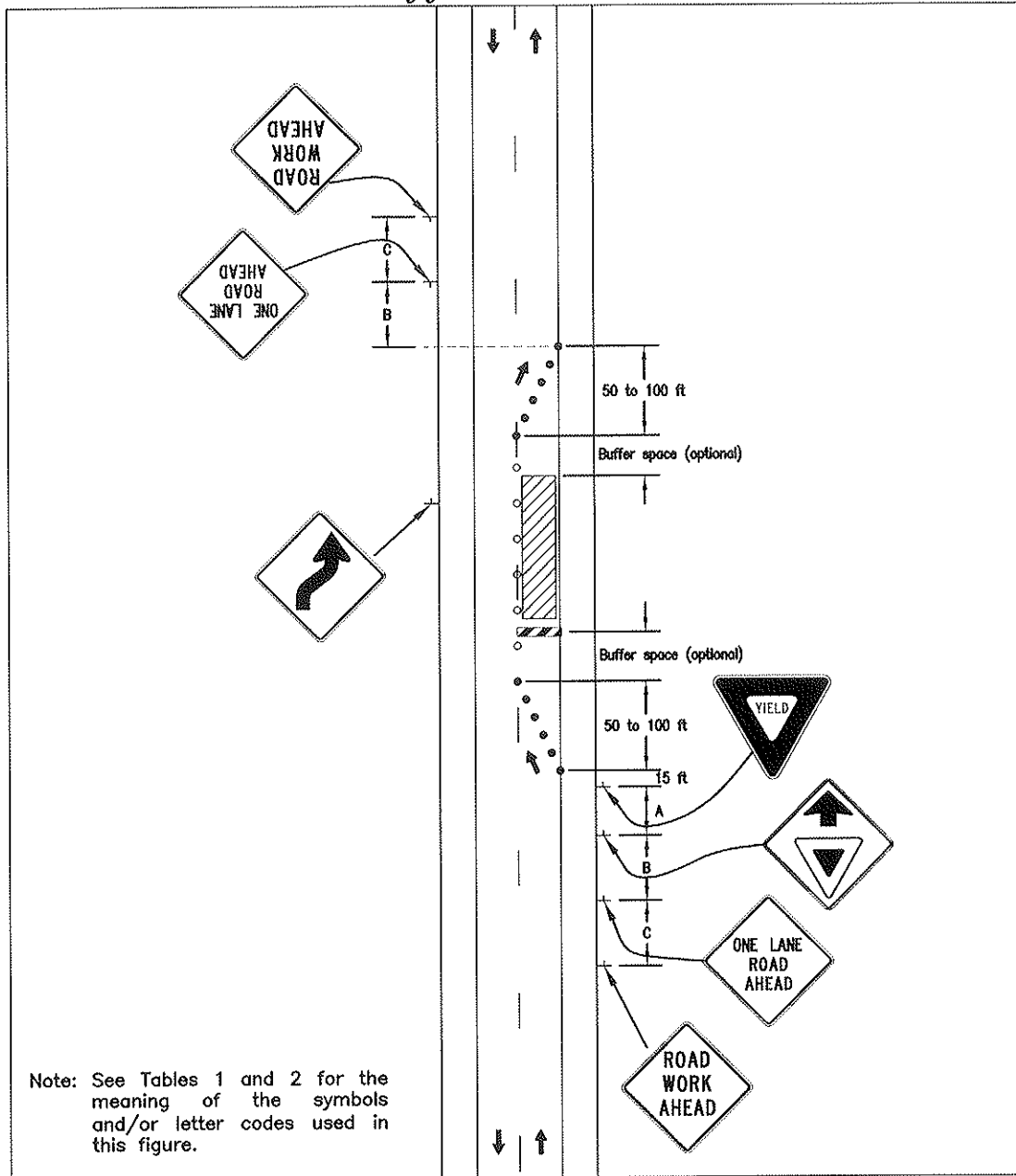

**Option:**

1. This TTC zone application may be used as an alternate to the TTC application shown in Figure 6H-10 (using flaggers) when the following conditions exist:
  - a. Vehicular traffic volume is such that sufficient gaps exist for vehicular traffic that must yield.
  - b. Road users from both directions are able to see approaching vehicular traffic through and beyond the worksite and have sufficient visibility of approaching vehicles.
2. The Type B flashing warning lights may be placed on the ROAD WORK AHEAD and the ONE LANE ROAD AHEAD signs whenever a night lane closure is necessary.

SECTION NO. 4100	DRAWING NO. 5.5
REV.D.	
<i>Traffic Control Typical Applications</i>	
- TA-11 -	
CITY OF FARGO ENGINEERING DEPARTMENT	
APPROVED JAK	DATE 1/2/2013

# TA-15 Work in the Center of a Road with Low Traffic Volumes

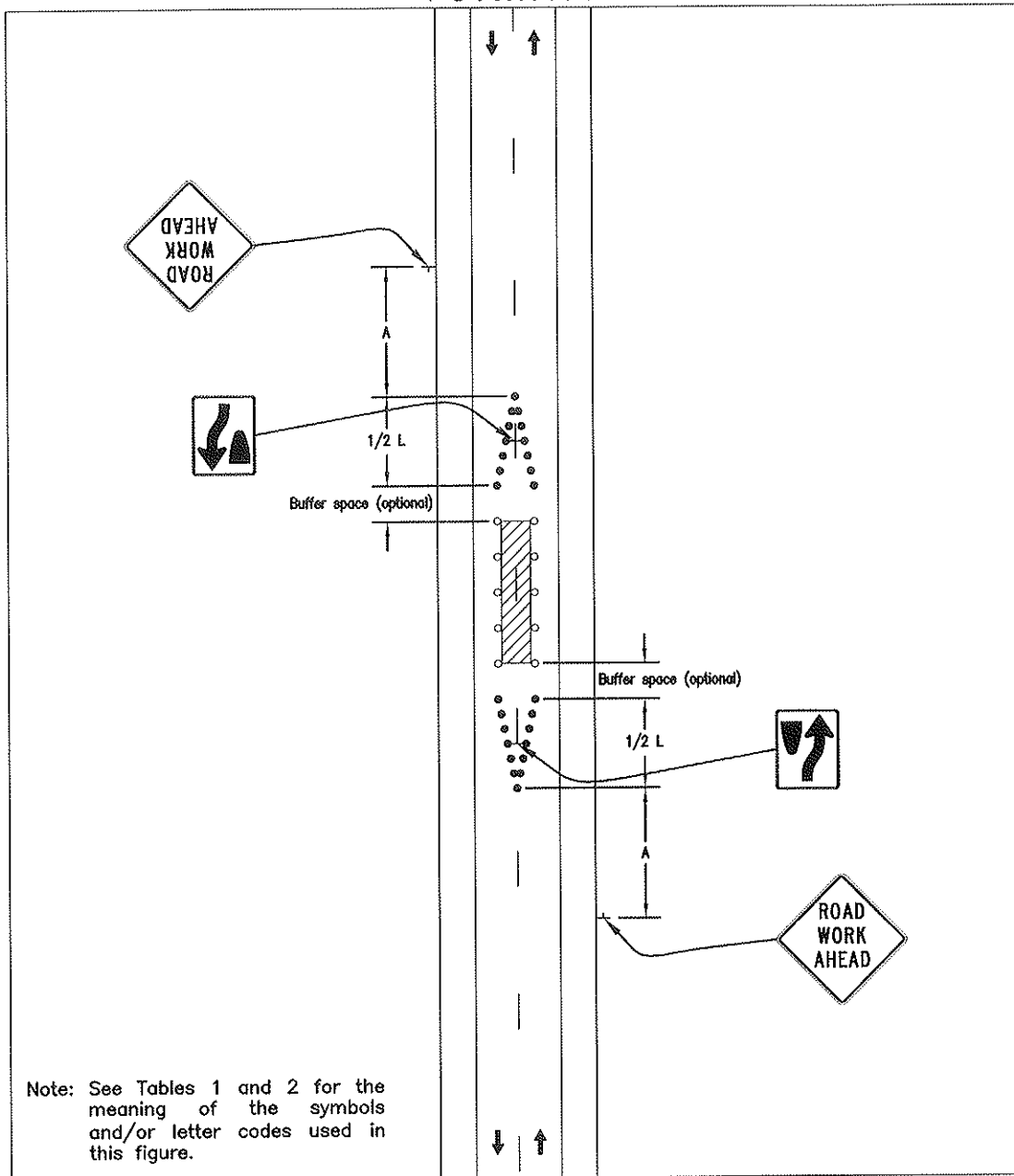

### Guidance:

1. The lanes on either side of the center work space should have a minimum width of 9 feet as measured from the near edge of the channelizing devices to the edge of the pavement or the outside edge of the paved shoulder.

### Option:

2. Flashing warning lights and/or flags may be used to call attention to the advance warning signs.
3. If the closure continues overnight, warning lights may be used on the channelizing devices.
4. A lane width of 9 feet may be used for short-term stationary work on low-volume, low-speed roadways when motor vehicle traffic does not include longer and wider heavy commercial vehicles.
5. A work vehicle displaying high-intensity rotating, flashing, oscillating, or strobe lights may be used instead of the channelizing devices forming the tapers or the high-level warning devices.
6. Vehicle hazard warning signals may be used to supplement high-intensity rotating, flashing, oscillating, or strobe lights.

### Standard:

7. Vehicle hazard warning signals shall not be used instead of the vehicle's high-intensity rotating, flashing, oscillating, or strobe lights.

SECTION NO. 4100	DRAWING NO. 5.6
REV.D.	
<i>Traffic Control Typical Applications</i> - TA-15 -	
CITY OF FARGO ENGINEERING DEPARTMENT	
APPROVED JAP	DATE 1/2/2013



# TA-18 Lane Closure on a Minor Street

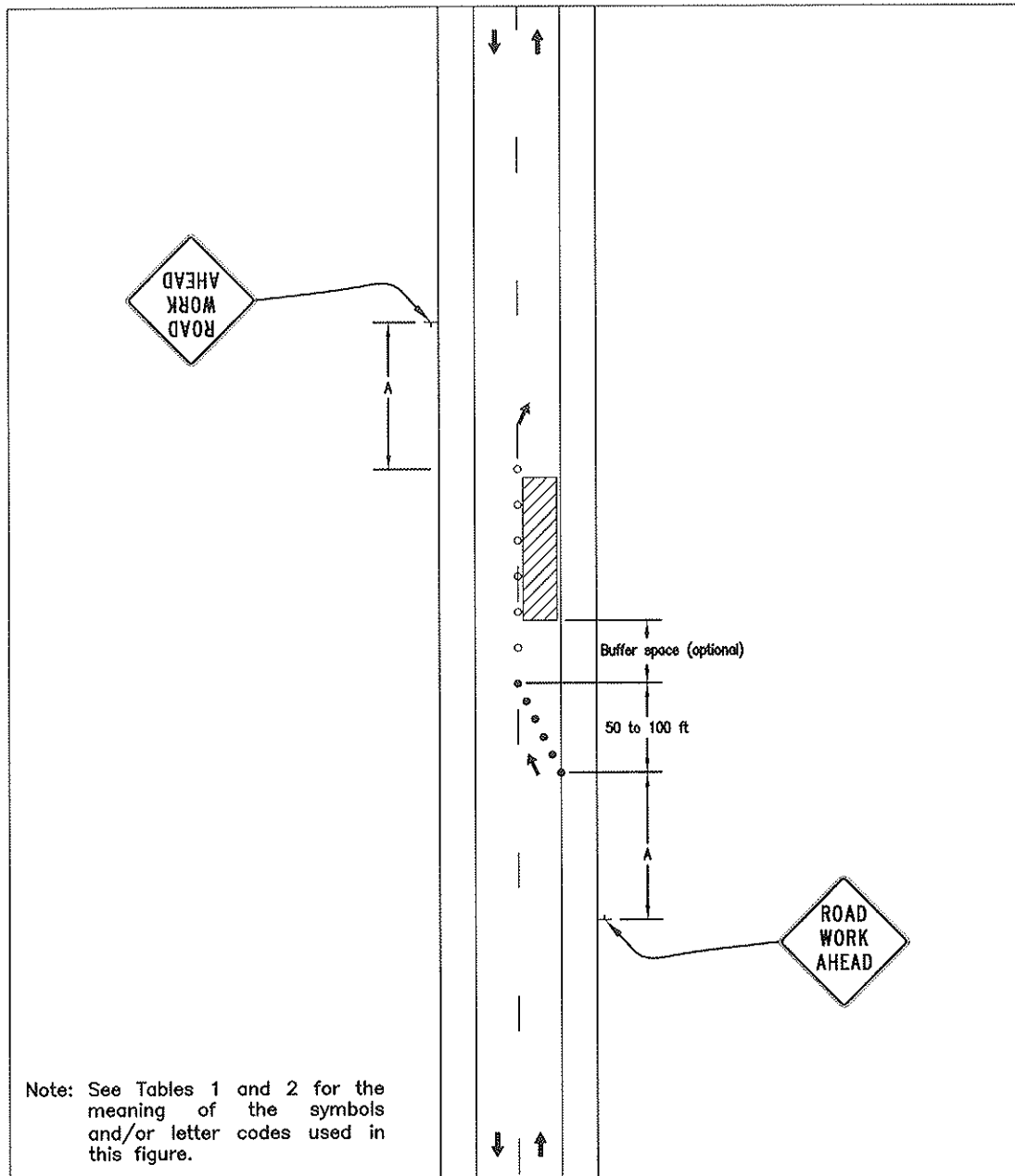

**Standard:**

1. This TTC shall be used only for low-speed facilities having low traffic volumes.

**Option:**

2. Where the work space is short, where road users can see the roadway beyond, and where volume is low, vehicular traffic may be self-regulating.

**Standard:**

3. Where vehicular traffic cannot effectively self-regulate, one or two flaggers shall be used as illustrated in Figure 6H-10.

**Option:**

- 4. Flashing warning lights and/or flags may be used to call attention to the advance warning signs.
- 5. A truck-mounted attenuator may be used on the work vehicle and the shadow vehicle.

SECTION NO. 4100	DRAWING NO. 5.7
REV.D.	
<i>Traffic Control Typical Applications</i>	
<i>- TA-18 -</i>	
CITY OF FARGO ENGINEERING DEPARTMENT	
APPROVED JAA	DATE 1/2/2013

# TA-19 Detour for One Travel Direction

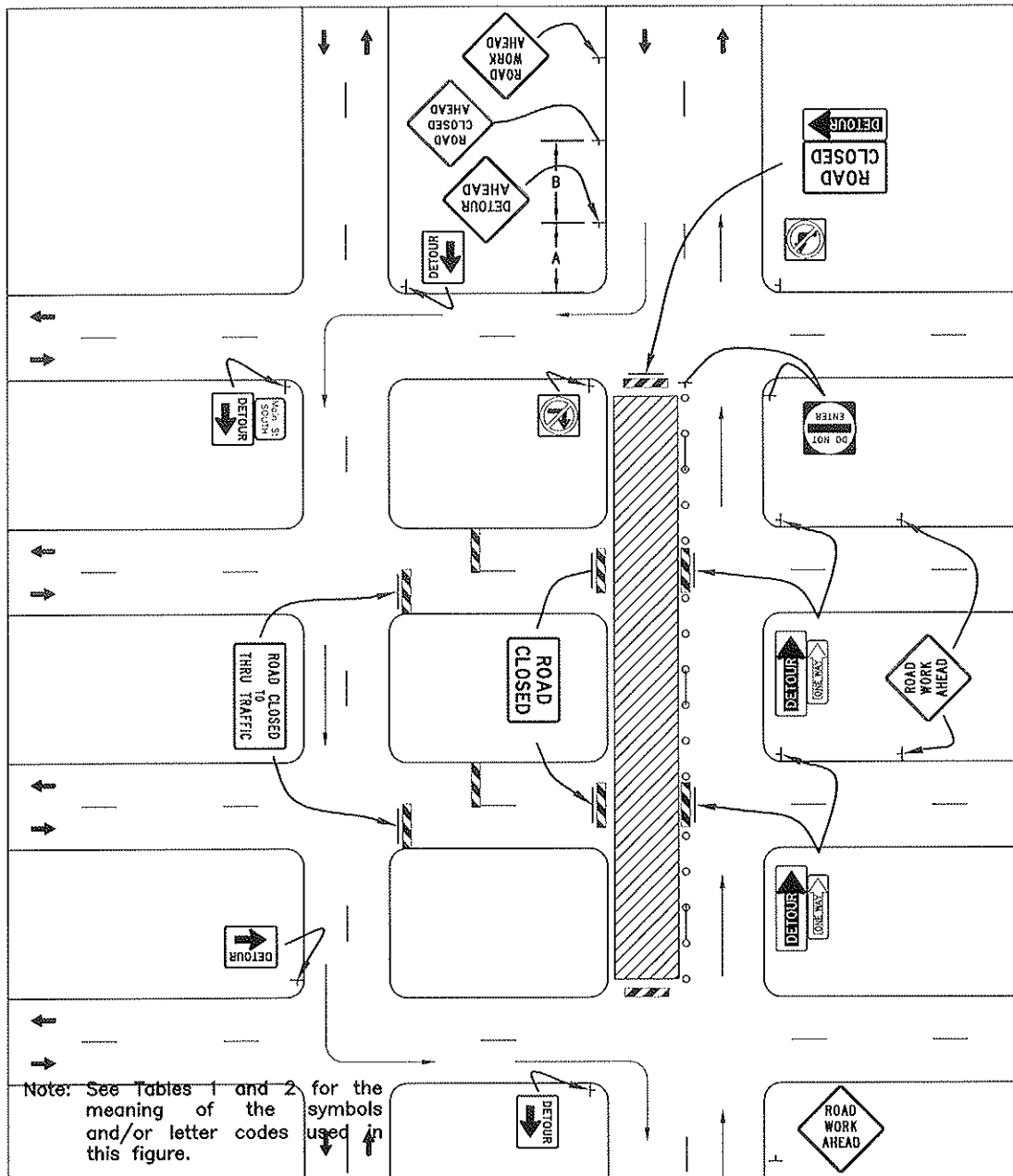

**Guidance:**

1. This plan should be used for streets without posted route numbers.
2. On multi-lane streets, Detour signs with an Advance Turn Arrow should be used in advance of a turn.

**Option:**

3. The STREET CLOSED legend may be used in place of ROAD CLOSED.
4. Additional DO NOT ENTER signs may be used at intersections with intervening streets.
5. Warning lights may be used on Type 3 Barricades.
6. Detour signs may be located on the far side of intersections.
7. A Street Name sign may be mounted with the Detour sign. The Street Name sign may be either white on green or black on orange.

**Standard:**

8. When used, the Street Name sign shall be placed above the Detour sign.

SECTION NO. 4100	DRAWING NO. 5.8
REV.D.	
<i>Traffic Control Typical Applications</i>	
- TA-19 -	
CITY OF FARGO ENGINEERING DEPARTMENT	
APPROVED J A A	DATE 1/2/2013

# TA-20 Detour for a Closed Street

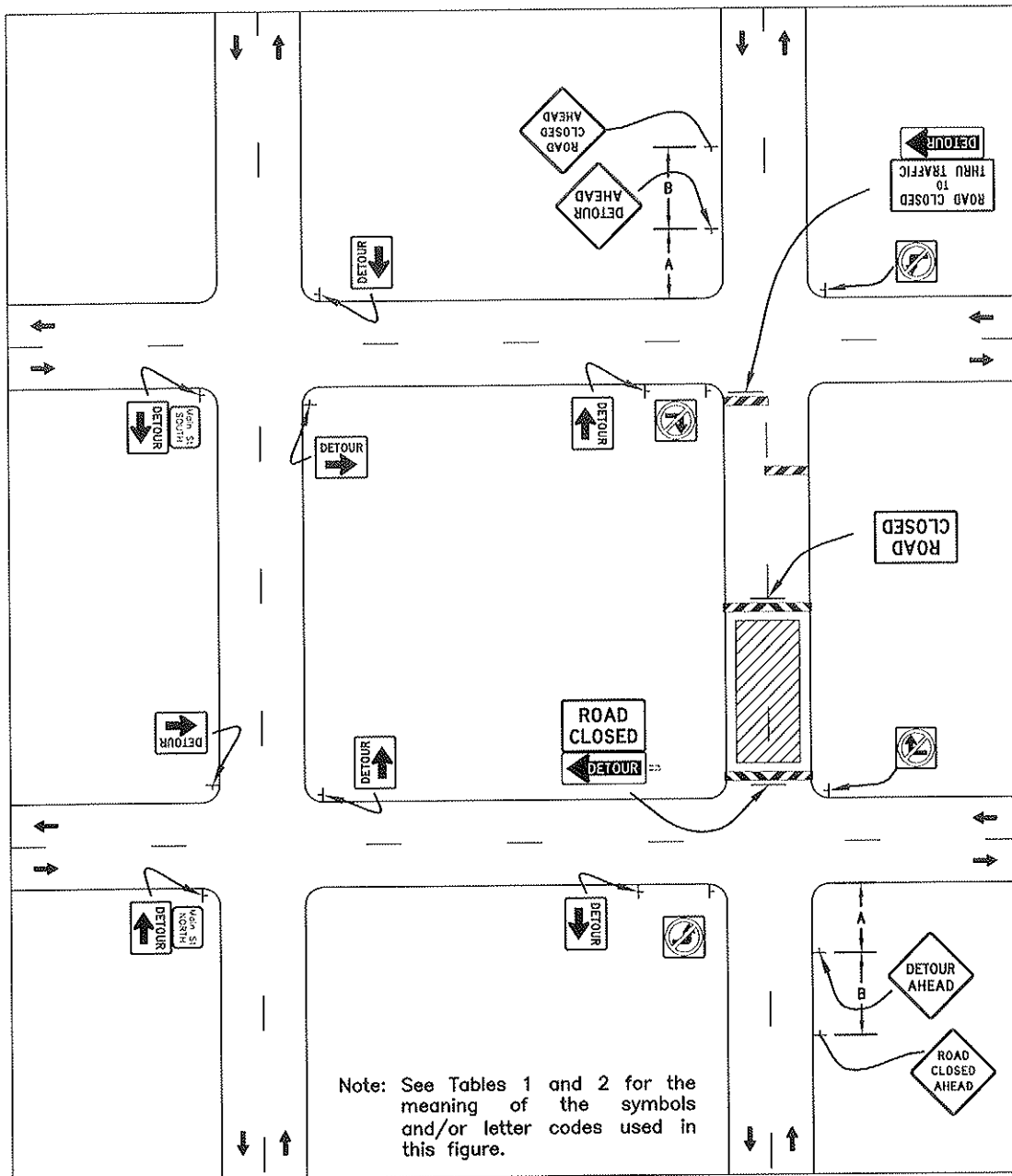

### Guidance:

1. This plan should be used for streets without posted route numbers.
2. On multi-lane streets, Detour signs with an Advance Turn Arrow should be used in advance of a turn.

### Option:

3. Flashing warning lights and/or flags may be used to call attention to the advance warning signs.
4. Flashing warning lights may be used on Type 3 Barricades.
5. Detour signs may be located on the far side of intersections. A Detour sign with an advance arrow may be used in advance of a turn.
6. A Street Name sign may be mounted with the Detour sign. The Street Name sign may be either white on green or black on orange.

### Standard:

7. When used, the Street Name sign shall be placed above the Detour sign.

SECTION NO. 4100	DRAWING NO. 5.9
REV.D.	
<i>Traffic Control Typical Applications</i>	
- TA-20 -	
CITY OF FARGO ENGINEERING DEPARTMENT	
APPROVED JAA	DATE 1/2/2013

# TA-21 Lane Closure on the Near Side of an Intersection

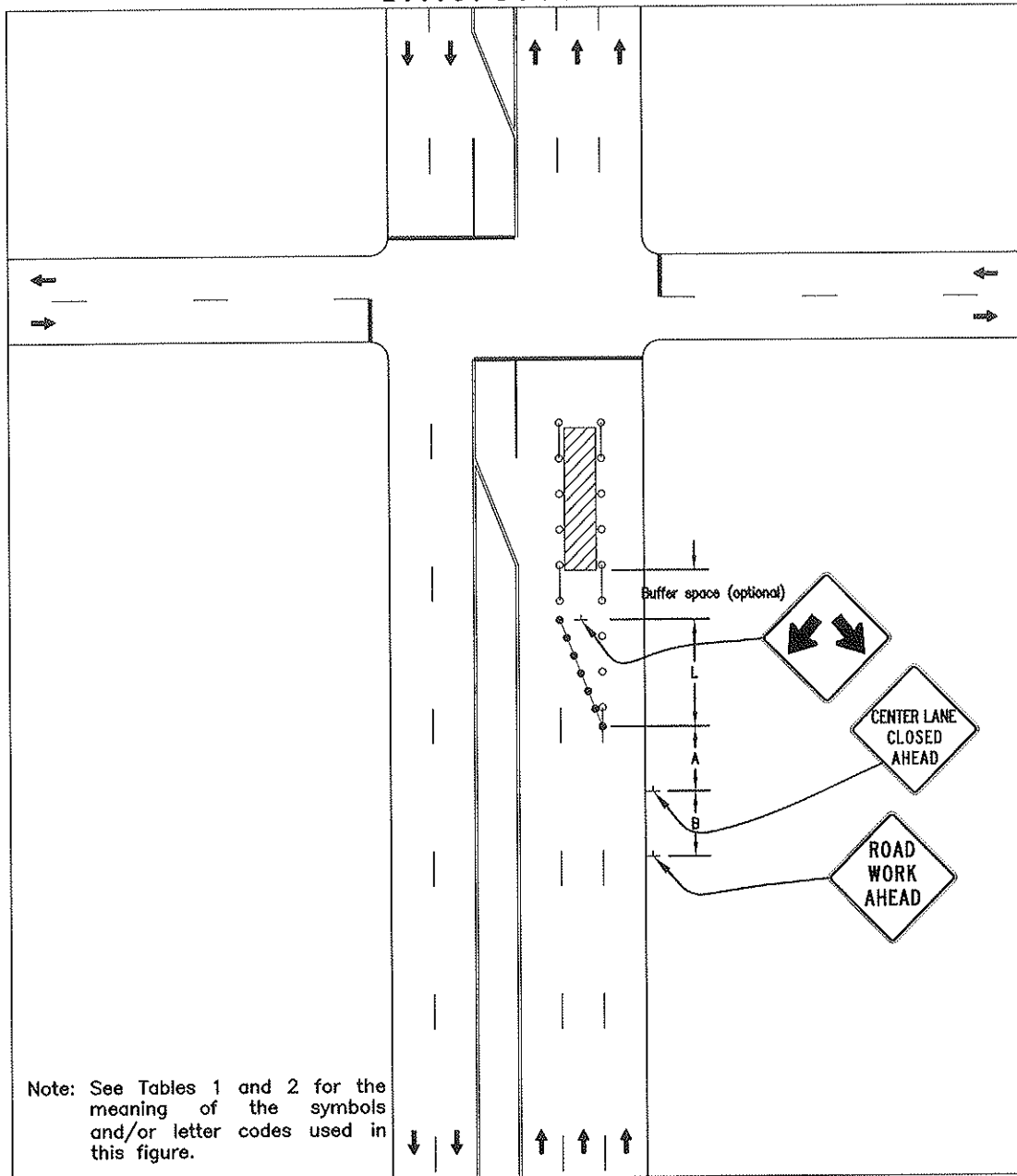

**Standard:**

1. The merging taper shall direct vehicular traffic into either the right-hand or left-hand lane, but not both.

**Guidance:**

2. In this typical application, a left taper should be used so that right-turn movements will not impede through motor vehicle traffic. However, the reverse should be true for left-turn movements.
3. If the work space extends across a crosswalk, the crosswalk should be closed using the information and devices shown in Figure 6H-29.

**Option:**

4. Flashing warning lights and/or flags may be used to call attention to the advance warning signs.
5. A shadow vehicle with a truck-mounted attenuator may be used.
6. A work vehicle with high-intensity rotating, flashing, oscillating, or strobe lights may be used with the high-level warning device.
7. Vehicle hazard warning signals may be used to supplement high-intensity rotating, flashing, oscillating, or strobe lights.

**Standard:**

8. Vehicle hazard warning signals shall not be used instead of the vehicle's high-intensity rotating, flashing, oscillating, or strobe lights.

SECTION NO. 4100	DRAWING NO. 5.10
REV.D.	
<i>Traffic Control Typical Applications</i>	
- TA-21 -	
CITY OF FARGO ENGINEERING DEPARTMENT	
APPROVED J A A	DATE 1/2/2013

# TA-22 Right-Hand Lane Closure on the Far Side of an Intersection

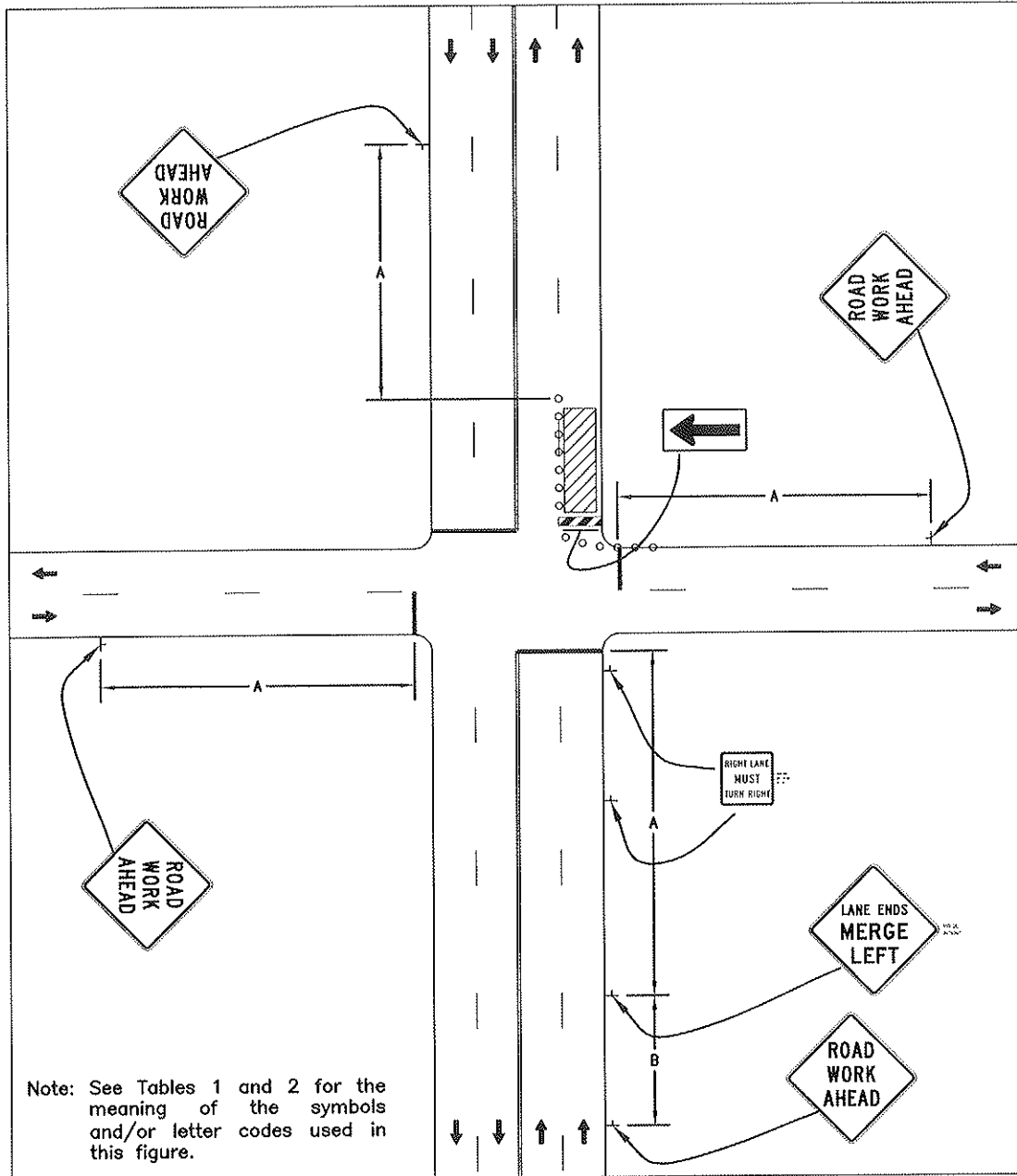

**Guidance:**

1. If the work space extends across a crosswalk, the crosswalk should be closed using the information and devices shown in Figure 6H-29.

**Option:**

2. The normal procedure is to close on the near side of the intersection any lane that is not carried through the intersection. However, when this results in the closure of a right-hand lane having significant right turning movements, then the right-hand lane may be restricted to right turns only, as shown. This procedure increases the through capacity by eliminating right turns from the open through lane.
3. For intersection approaches reduced to a single lane, left-turning movements may be prohibited to maintain capacity for through vehicular traffic.
4. Flashing warning lights and/or flags may be used to call attention to the advance warning signs.
5. Where the turning radius is large, it may be possible to create a right-turn island using channelizing devices or pavement markings.

SECTION NO. 4100	DRAWING NO. 5.11
REV.D.	
<i>Traffic Control Typical Applications</i>	
- TA-22 -	
CITY OF FARGO ENGINEERING DEPARTMENT	
APPROVED JAP	DATE 1/2/2013

# TA-23 Left-Hand Lane Closure on the Far Side of an Intersection

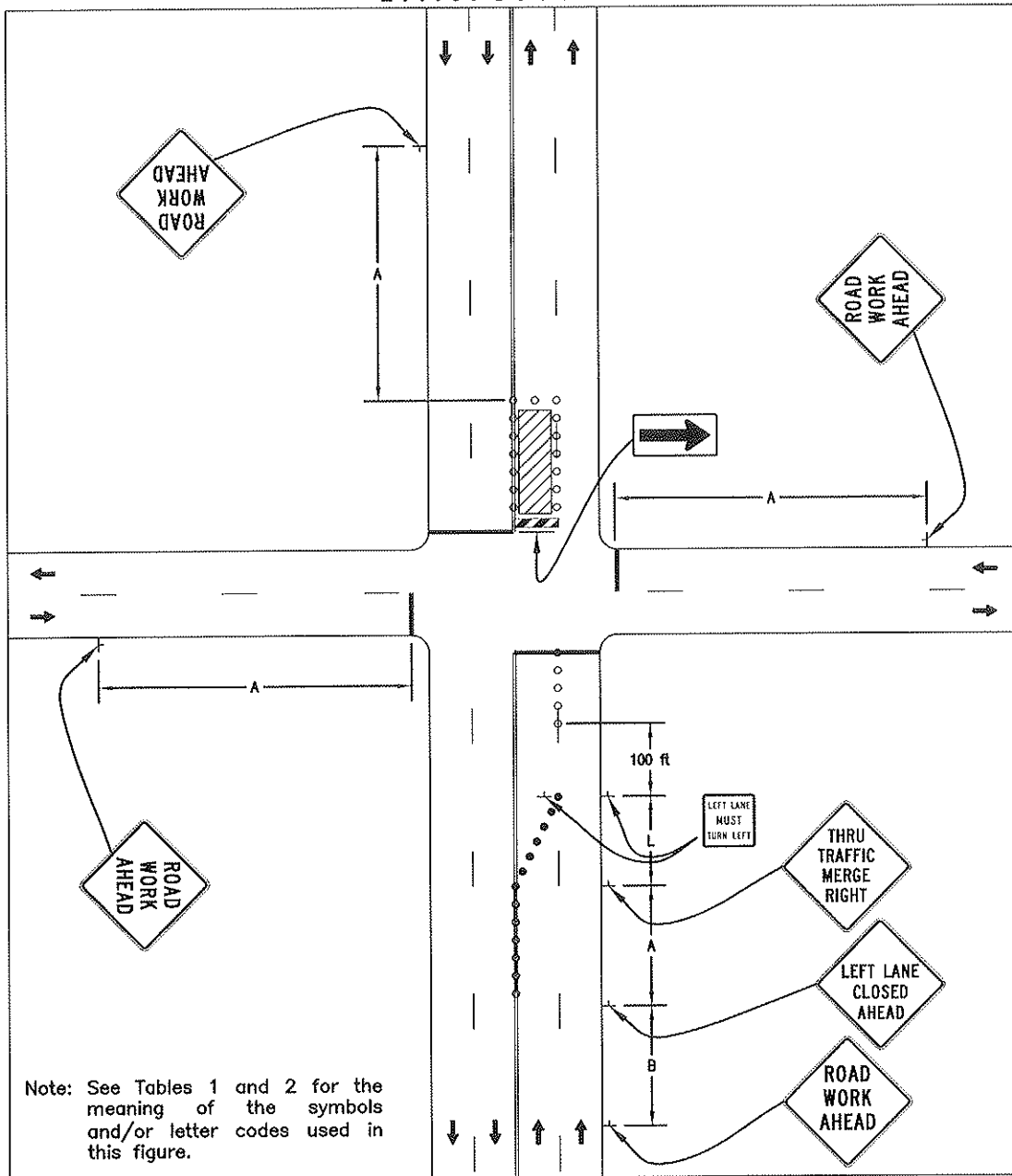

**Guidance:**

1. If the work space extends across a crosswalk, the crosswalk should be closed using the information and devices shown in Figure 6H-29.

**Option:**

2. Flashing warning lights and/or flags may be used to call attention to the advance warning signs.
3. The normal procedure is to close on the near side of the intersection any lane that is not carried through the intersection. However, when this results in the closure of a left lane having significant left-turning movements, then the left lane may be reopened as a turn bay for left turns only, as shown.

**Support:**

4. By first closing off the left lane and then reopening it as a turn bay, the left-turn bay allows storage of turning vehicles so that the movement of through traffic is not impeded. A left-turn bay that is long enough to accommodate all turning vehicles during a traffic signal cycle will provide the maximum benefit for through traffic. Also, an island is created with channelizing devices that allows the LEFT LANE MUST TURN LEFT sign to be repeated on the left adjacent to the lane that it controls.

SECTION NO. 4100	DRAWING NO. 5.12
REV.D.	
<i>Traffic Control Typical Applications</i>	
- TA-23 -	
CITY OF FARGO ENGINEERING DEPARTMENT	
APPROVED JAA	DATE 1/2/2013

# TA-24 Half Road Closure on the Far Side of an Intersection

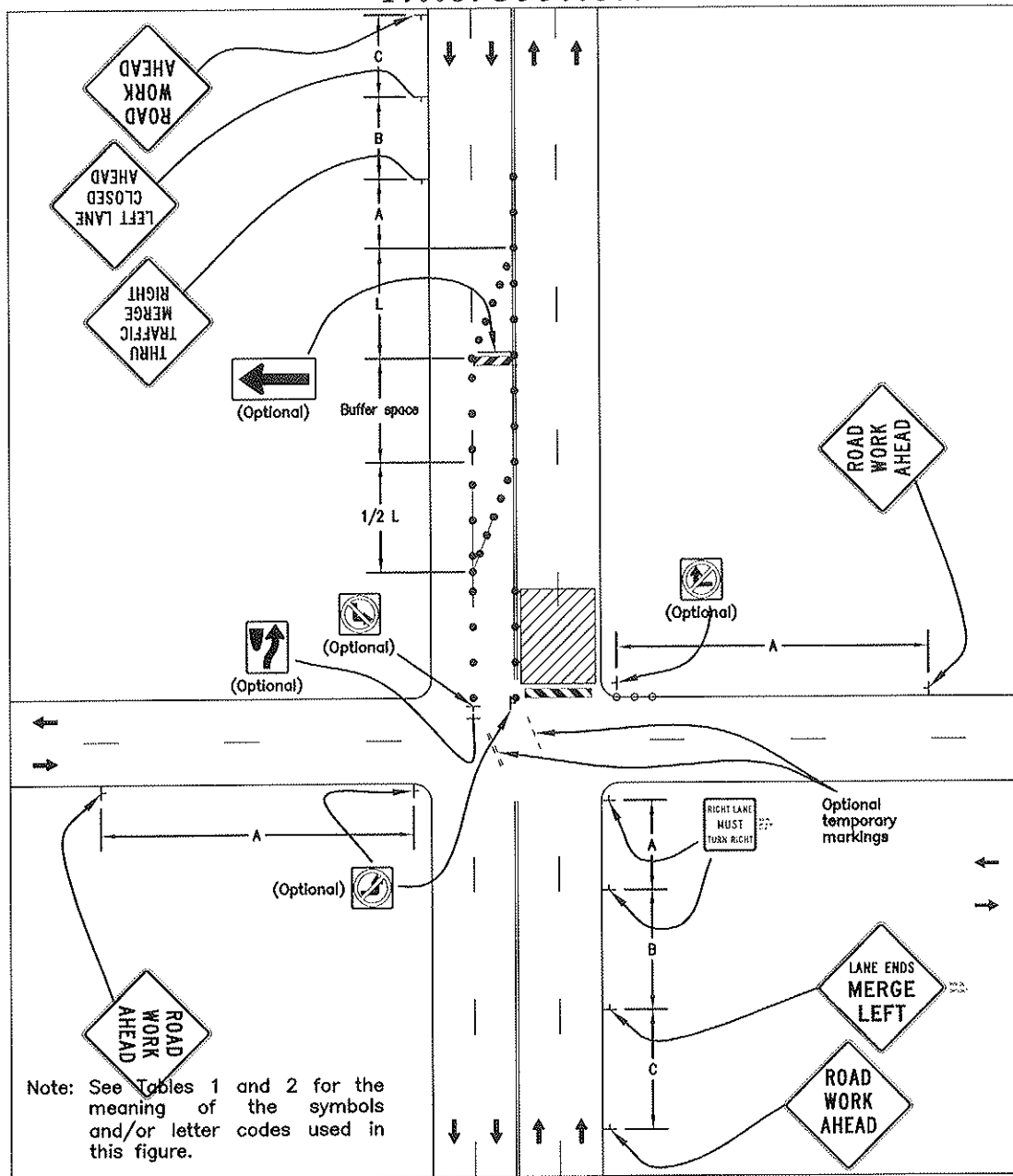

### Guidance:

1. If the work space extends across a crosswalk, the crosswalk should be closed using the information and devices shown in Figure 6H-29.
2. When turn prohibitions are implemented, two turn prohibition signs should be used, one on the near side and, space permitting, one on the far side of the intersection.

### Option:

3. A buffer space may be used between opposing directions of vehicular traffic as shown in this application.
4. The normal procedure is to close on the near side of the intersection any lane that is not carried through the intersection. However, if there is a significant right-turning movement, then the right-hand lane may be restricted to right turns only, as shown.
5. Where the turning radius is large, a right-turn island using channelizing devices or pavement markings may be used.
6. There may be insufficient space to place the back-to-back Keep Right sign and No Left Turn symbol signs at the end of the row of channelizing devices separating opposing vehicular traffic flows. In this situation, the No Left Turn symbol sign may be placed on the right and the Keep Right sign may be omitted.
7. For intersection approaches reduced to a single lane, left-turning movements may be prohibited to maintain capacity for through vehicular traffic.
8. Flashing warning lights and/or flags may be used to call attention to advance warning signs.
9. Temporary pavement markings may be used to delineate the travel path through the intersection.

### Support:

10. Keeping the right-hand lane open increases the through capacity by eliminating right turns from the open through lane.
11. A temporary turn island reinforces the nature of the temporary exclusive right-turn lane and enables a second RIGHT LANE MUST TURN RIGHT sign to be placed in the island.

SECTION NO. 4100	DRAWING NO. 5.13
REV.D.	
<i>Traffic Control Typical Applications</i>	
- TA-24 -	
CITY OF FARGO ENGINEERING DEPARTMENT	
APPROVED JAA	DATE 1/2/2013

# TA-25 Multiple Lane Closures at an Intersection

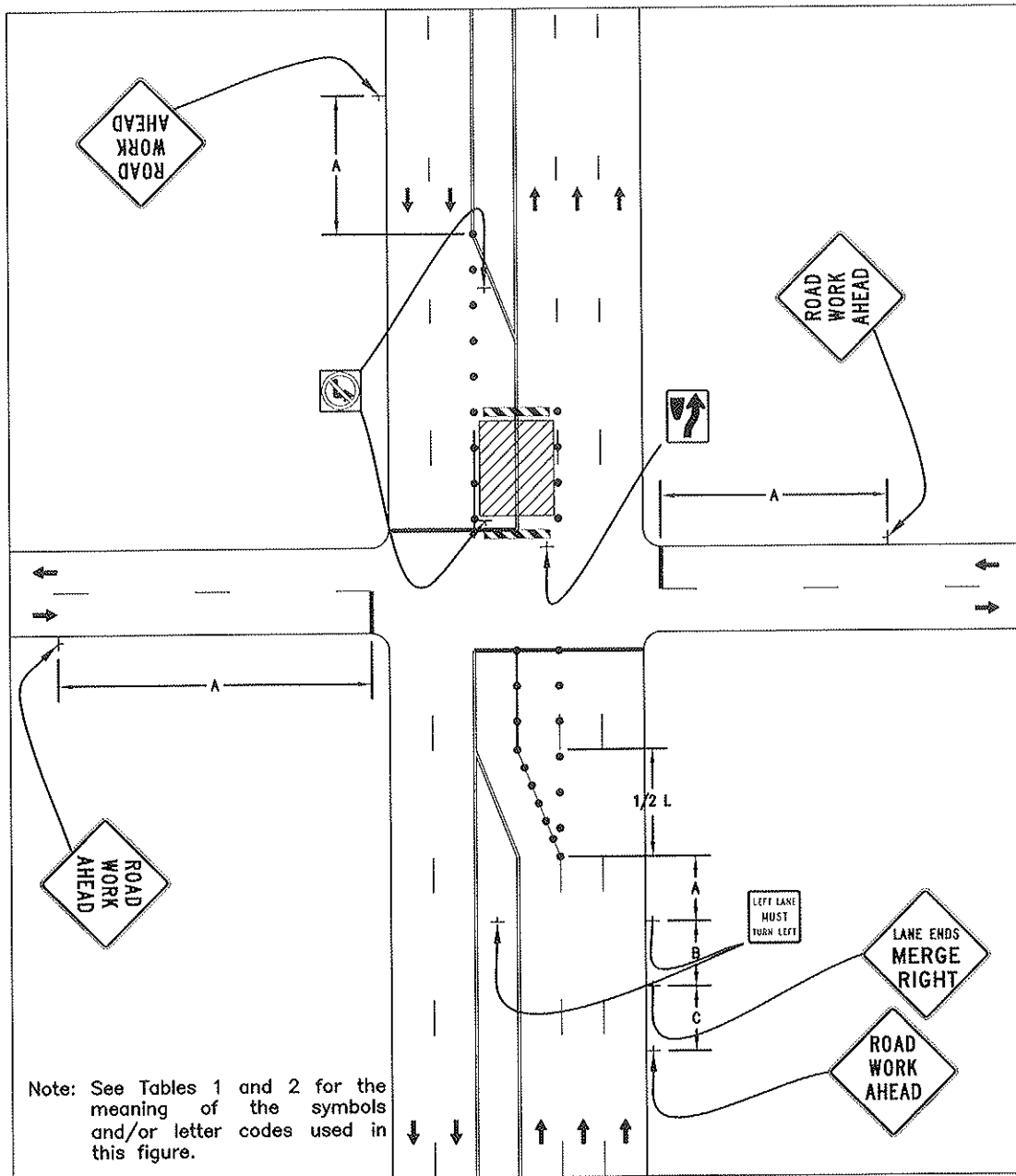

**Guidance:**

1. If the work space extends across a crosswalk, the crosswalk should be closed using the information and devices shown in Figure 6H-29.
2. If the left through lane is closed on the near-side approach, the LEFT LANE MUST TURN LEFT sign should be placed in the median to discourage through vehicular traffic from entering the left-turn bay.

**Support:**

3. The normal procedure is to close on the near side of the intersection any lane that is not carried through the intersection.

**Option:**

4. If the left-turning movement that normally uses the closed turn bay is small and/or the gaps in opposing vehicular traffic are frequent, left turns may be permitted on that approach.
5. Flashing warning lights and/or flags may be used to call attention to the advance warning signs.

SECTION NO. 4100	DRAWING NO. 5.14
REV.D.	
<i>Traffic Control Typical Applications</i>	
- TA-25 -	
CITY OF FARGO ENGINEERING DEPARTMENT	
APPROVED JAA	DATE 1/2/2013



# TA-26 Closure in the Center of an Intersection

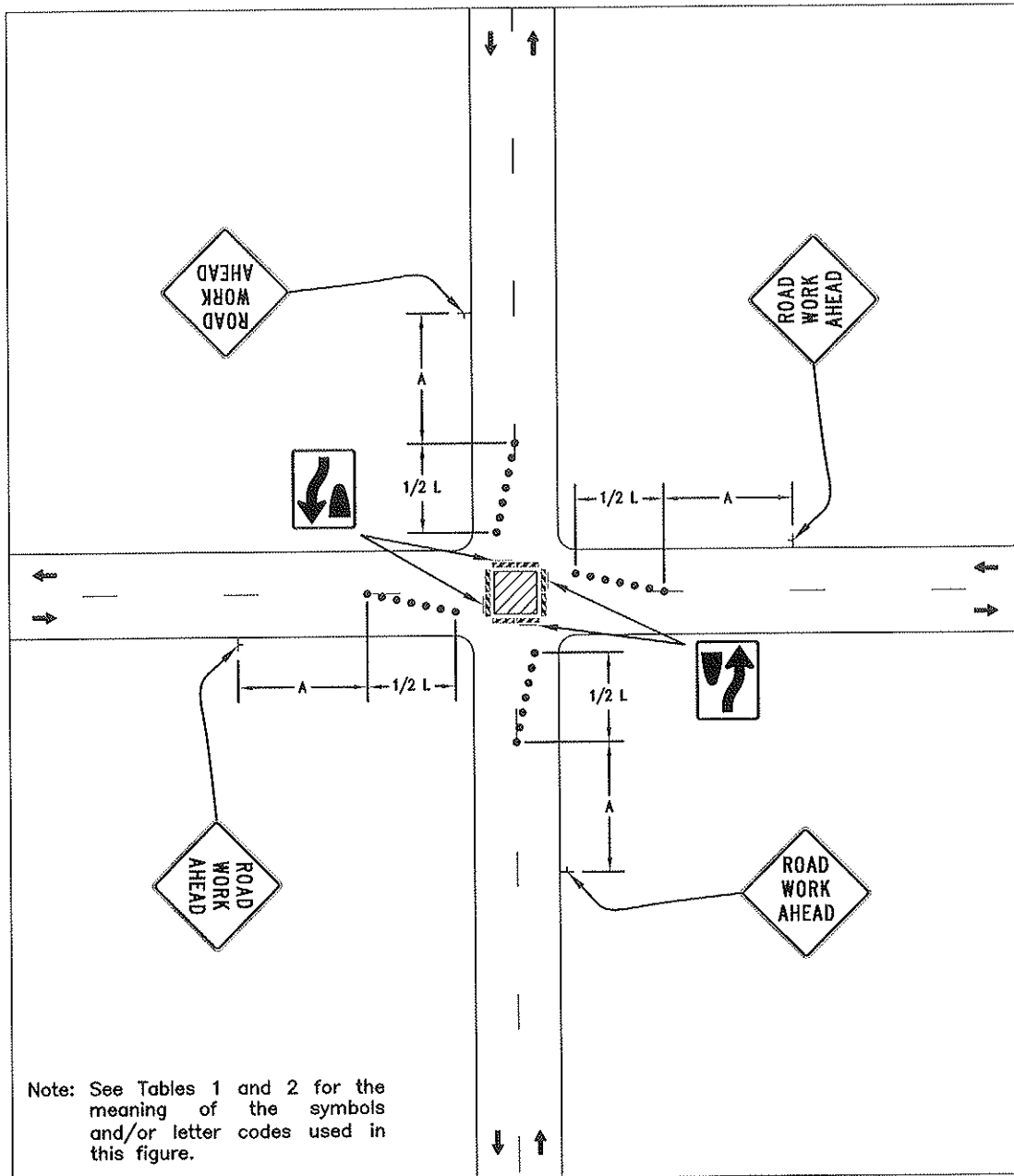

**Guidance:**

1. All lanes should be a minimum of 10 feet in width as measured to the near face of the channelizing devices.

**Option:**

- 2. A high-level warning device may be placed in the work space, if there is sufficient room.
- 3. For short-term use on low-volume, low-speed roadways with vehicular traffic that does not include longer and wider heavy commercial vehicles, a minimum lane width of 9 feet may be used.
- 4. Flashing warning lights and/or flags may be used to call attention to advance warning signs.
- 5. Unless the streets are wide, it may be physically impossible to turn left, especially for large vehicles. Left turns may be prohibited as required by geometric conditions.
- 6. For short-duration work operations, the channelizing devices may be eliminated if a vehicle displaying high-intensity rotating, flashing, oscillating, or strobe lights is positioned in the work space.
- 7. Vehicle hazard warning signals may be used to supplement high-intensity rotating, flashing, oscillating, or strobe lights.

**Standard:**

8. Vehicle hazard warning signals shall not be used instead of the vehicle's high-intensity rotating, flashing, oscillating, or strobe lights.

SECTION NO. 4100	DRAWING NO. 5.15
REV.D.	
<i>Traffic Control Typical Applications</i>	
- TA-26 -	
CITY OF FARGO ENGINEERING DEPARTMENT	
APPROVED JAP	DATE 1/2/2013

# TA-27 Closure at the Side of an Intersection

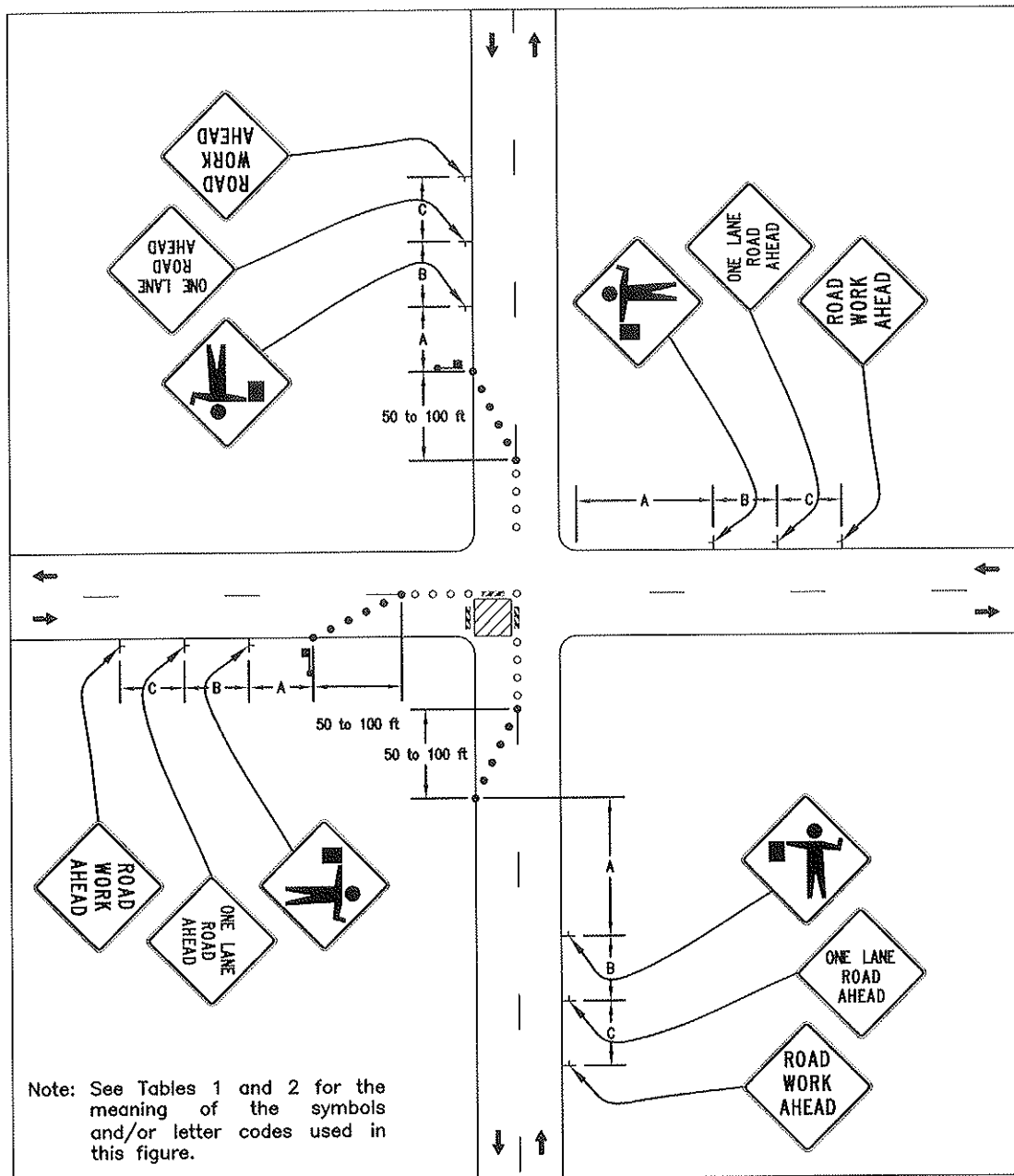

### Guidance:

1. The situation depicted can be simplified by closing one or more of the intersection approaches. If this cannot be done, and/or when capacity is a problem, through vehicular traffic should be directed to other roads or streets.
2. Depending on road user conditions, flagger(s) or uniformed law enforcement officer(s) should be used to direct road users within the intersection.

### Standard:

3. At night, flagger stations shall be illuminated, except in emergencies.

### Option:

1. Flashing warning lights and/or flags may be used to call attention to the advance warning signs.
2. For short-duration work operations, the channelizing devices may be eliminated if a vehicle displaying high-intensity rotating, flashing, oscillating, or strobe lights is positioned in the work space.
3. A BE PREPARED TO STOP sign may be added to the sign series.

### Guidance:

4. When used, the BE PREPARED TO STOP sign should be located before the Flagger symbol sign.
5. ONE LANE ROAD AHEAD signs should also be used to provide adequate advance warning.

### Support:

8. Turns can be prohibited as required by vehicular traffic conditions. Unless the streets are wide, it might be physically impossible to make certain turns, especially for large vehicles.

### Option:

9. Vehicle hazard warning signals may be used to supplement high-intensity rotating, flashing, oscillating, or strobe lights.

### Standard:

10. Vehicle hazard warning signals shall not be used instead of the vehicle's high-intensity rotating, flashing, oscillating, or strobe lights.

SECTION NO. 4100	DRAWING NO. 5.16
REV.D.	
<i>Traffic Control Typical Applications</i> - TA-27 -	
CITY OF FARGO ENGINEERING DEPARTMENT	
APPROVED JAA	DATE 1/2/2013

# TA-28 Sidewalk Detour or Diversion

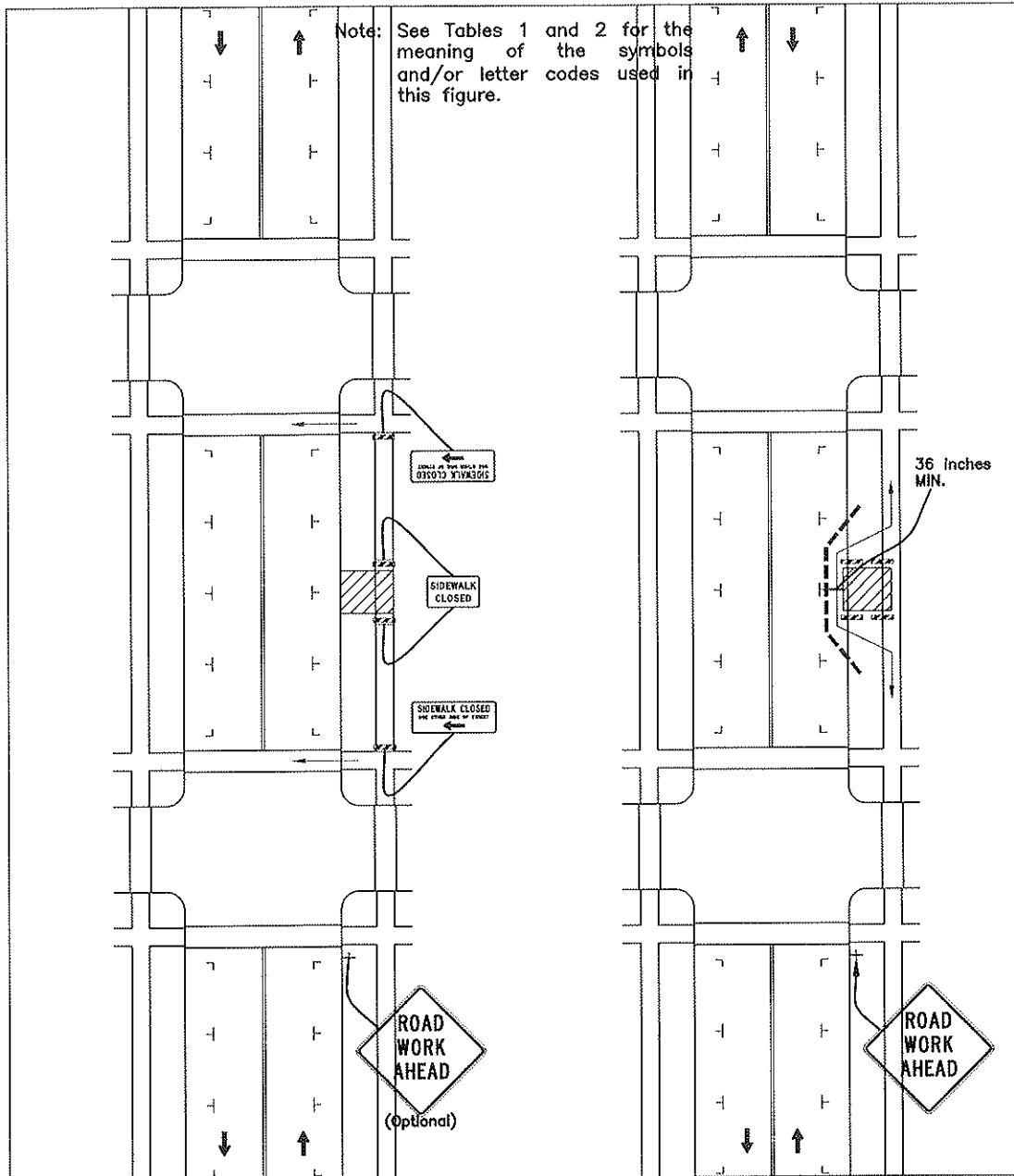

**Standard:**

1. At night, flagger stations shall be illuminated, except in emergencies.

**Guidance:**

2. Where high speeds are anticipated, a temporary traffic barrier and, if necessary, a crash cushion should be used to separate the temporary sidewalks from vehicular traffic.
3. Audible information devices should be considered where midblock closings and changed crosswalk areas cause inadequate communication to be provided to pedestrians who have visual disabilities.

**Option:**

4. Street lighting may be considered.
5. Only the TTC devices related to pedestrians are shown. Other devices, such as lane closure signing or ROAD NARROWS signs, may be used to control vehicular traffic.
6. For nighttime closures, Type A Flashing warning lights may be used on barricades that support signs and close sidewalks.
7. Type C Steady-Burn or Type D 360-degree Steady-Burn warning lights may be used on channelizing devices separating the temporary sidewalks from vehicular traffic flow.
8. Signs, such as KEEP RIGHT (LEFT), may be placed along a temporary sidewalk to guide or direct pedestrians.

SECTION NO. 4100	DRAWING NO. 5.17
REV.D.	
<i>Traffic Control Typical Applications</i>	
- TA-28 -	
CITY OF FARGO ENGINEERING DEPARTMENT	
APPROVED JAA	DATE 1/2/2013

# TA-29 Crosswalk Closures and Pedestrian Detours

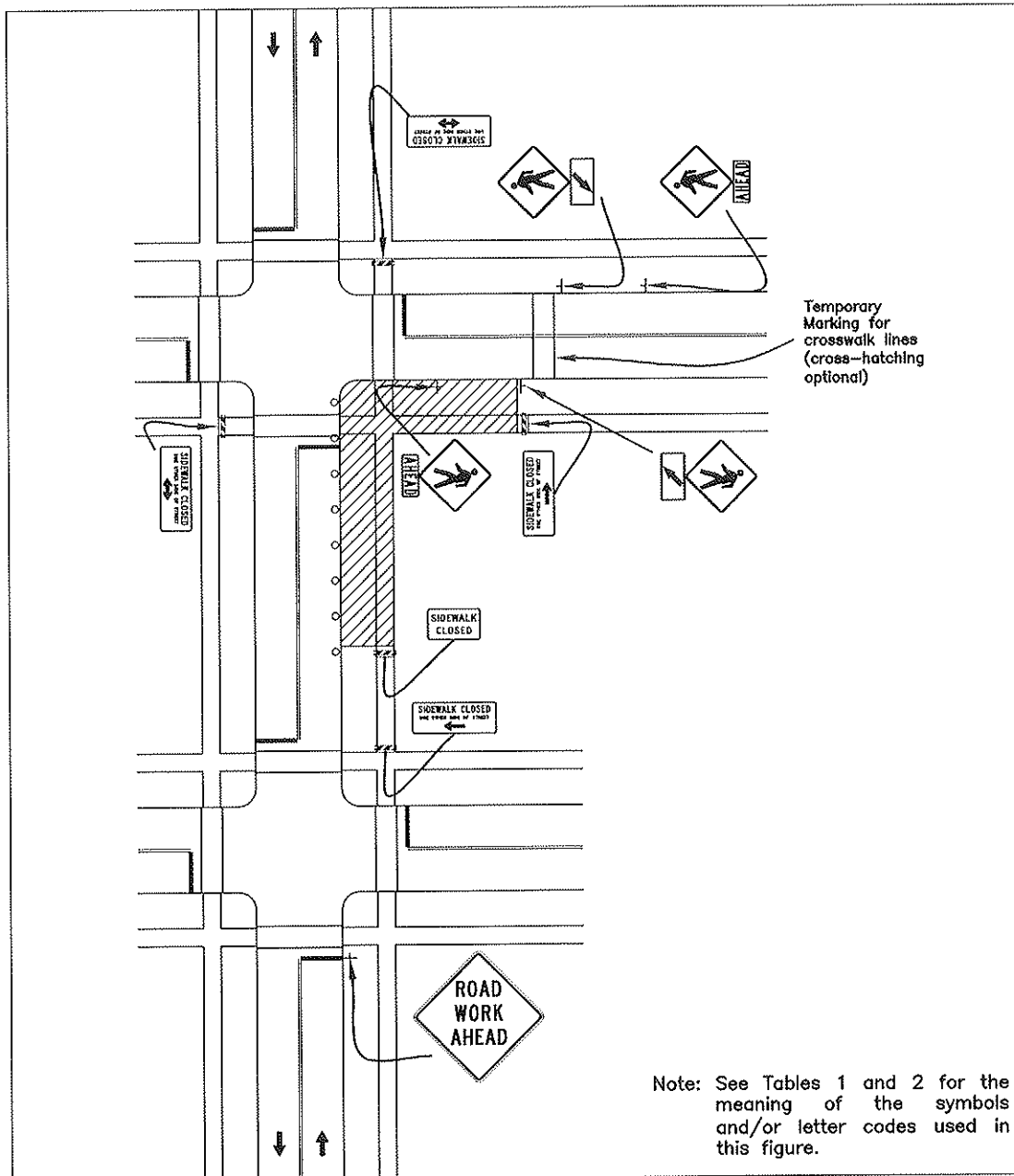

Note: See Tables 1 and 2 for the meaning of the symbols and/or letter codes used in this figure.

### Standard:

1. When crosswalks or other pedestrian facilities are closed or relocated, temporary facilities shall be detectable and shall include accessibility features consistent with the features present in the existing pedestrian facility.
2. Curb parking shall be prohibited for at least 50 feet in advance of the midblock crosswalk.

### Guidance:

1. Audible information devices should be considered where midblock closings and changed crosswalk areas cause inadequate communication to be provided to pedestrians who have visual disabilities.
2. Pedestrian traffic signal displays controlling closed crosswalks should be covered or deactivated.

### Option:

3. Street lighting may be considered.
4. Only the TTC devices related to pedestrians are shown. Other devices, such as lane closure signing or ROAD NARROWS signs, may be used to control vehicular traffic.
5. For nighttime closures, Type A Flashing warning lights may be used on barricades supporting signs and closing sidewalks.
6. Type C Steady-Burn or Type D 360-degree Steady-Burn warning lights may be used on channelizing devices separating the work space from vehicular traffic.
7. In order to maintain the systematic use of the fluorescent yellow-green background for pedestrian, bicycle, and school warning signs in a jurisdiction, the fluorescent yellow-green background for pedestrian, bicycle, and school warning signs may be used in TTC zones.

SECTION NO.	4100	DRAWING NO.	5.18
REV.D.			
<i>Traffic Control Typical Applications</i>			
- TA-29 -			
CITY OF FARGO ENGINEERING DEPARTMENT			
APPROVED JAP		DATE 1/2/2013	

# TA-30 Interior Lane Closure on a Multi-Lane Street

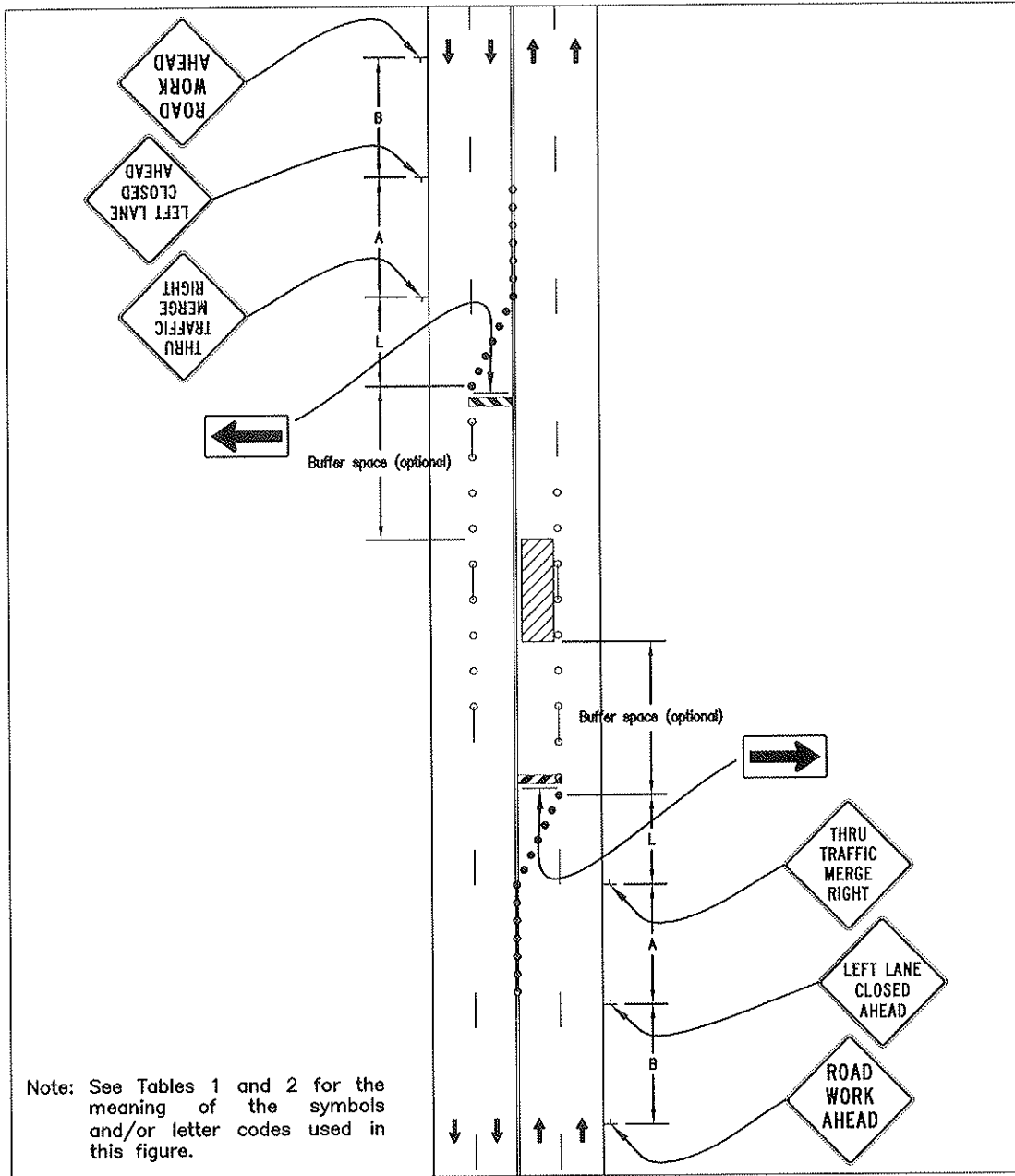

**Guidance:**

1. This information applies to low-speed, low-volume urban streets. Where speed or volume is higher, additional signing such as LEFT LANE CLOSED XX FT should be used between the signs shown.

**Option:**

2. The closure of the adjacent interior lane in the opposing direction may not be necessary, depending upon the activity being performed and the work space needed for the operation.
3. Shadow vehicles with a truck-mounted attenuator may be used.

SECTION NO. 4100	DRAWING NO. 5.19
REV.D.	
<i>Traffic Control Typical Applications</i>	
- TA-30 -	
CITY OF FARGO ENGINEERING DEPARTMENT	
APPROVED JAA	DATE 1/2/2013

# TA-33 Stationary Lane Closure on a Divided Highway

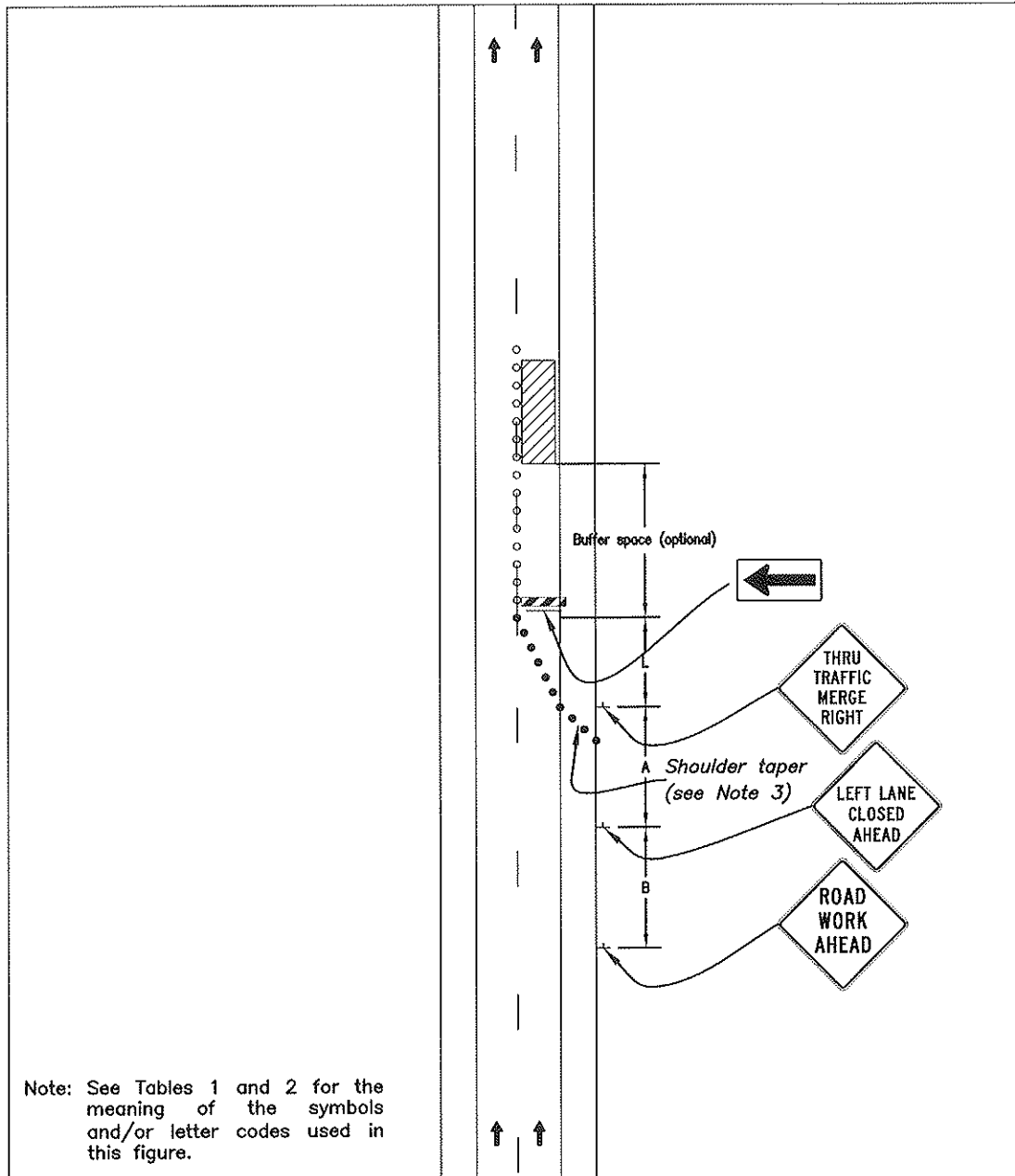

## Standard:

1. This information also shall be used when work is being performed in the lane adjacent to the median on a divided highway. In this case, the left lane closed signs and the corresponding lane ends signs shall be substituted.
2. When a side road intersects the highway within the ttc zone, additional ttc devices shall be placed as needed.

## Guidance:

3. When paved shoulders having a width of 8 feet or more are closed, channelizing devices should be used to close the shoulder in advance of the merging taper to direct vehicular traffic to remain within the traveled way.

## Option:

4. A truck-mounted attenuator may be used on the work vehicle and/or shadow vehicle.

## support:

5. Where conditions permit, restricting all vehicles, equipment, workers, and their activities to one side of the roadway might be advantageous.

## Standard:

6. An arrow board shall be used when a freeway lane is closed. When more than one freeway lane is closed, a separate arrow board shall be used for each closed lane.

SECTION NO. 4100	DRAWING NO. 5.20
REV.D.	
<i>Traffic Control Typical Applications</i> - TA-33 -	
CITY OF FARGO ENGINEERING DEPARTMENT	
APPROVED JAA	DATE 1/2/2013

# TA-46 Work in the Vicinity of a Grade Crossing

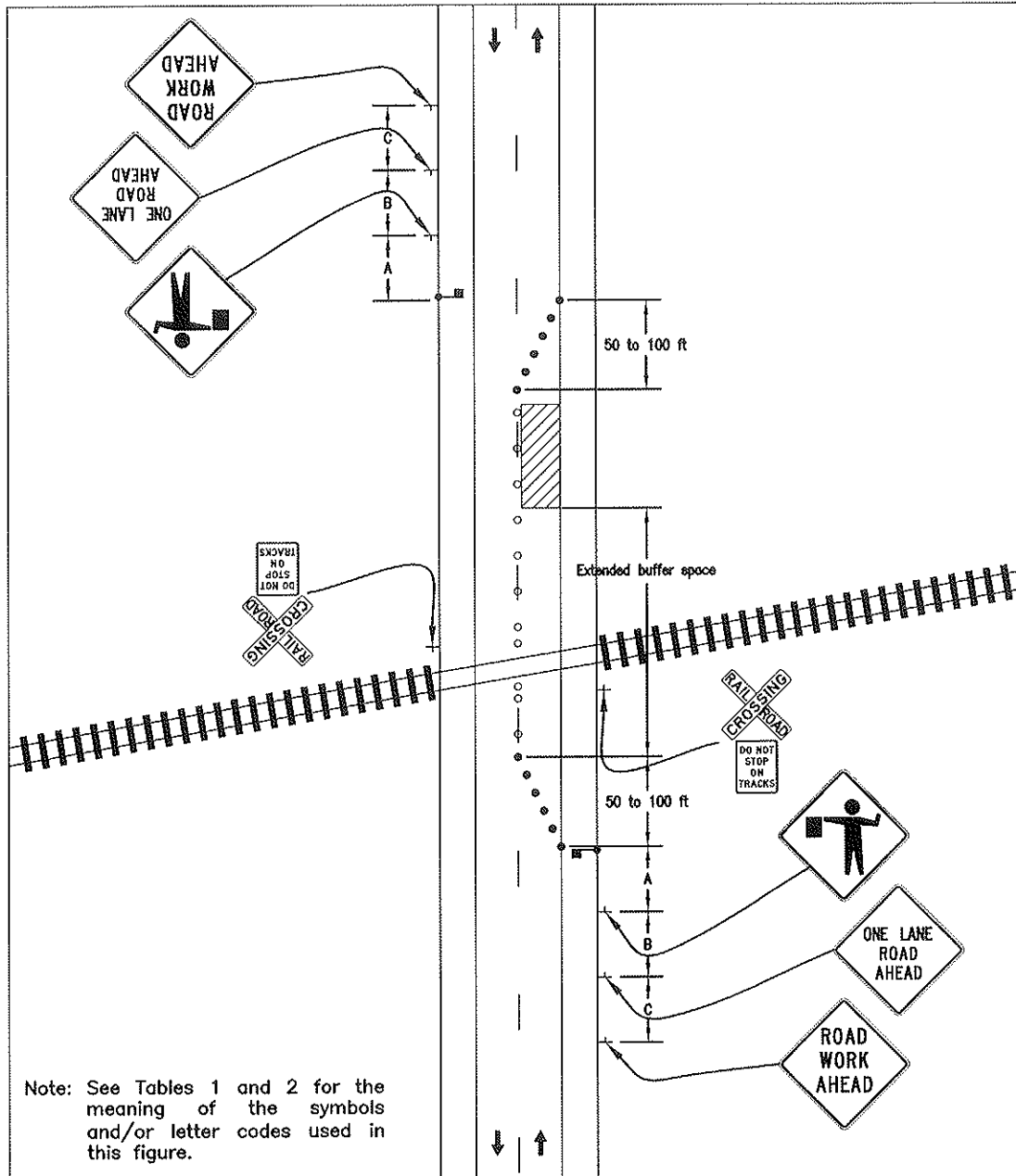

**Guidance:**

1. When grade crossings exist either within or in the vicinity of roadway work activities, extra care should be taken to minimize the probability of conditions being created, by lane restrictions, flagging, or other operations, where vehicles might be stopped within the grade crossing, considered as being 15 feet on either side of the closest and farthest rail.

**Standard:**

2. If the queuing of vehicles across active rail tracks cannot be avoided, a uniformed law enforcement officer or flagger shall be provided at the grade crossing to prevent vehicles from stopping within the grade crossing (as described in Note 1), even if automatic warning devices are in place.

**Guidance:**

3. Early coordination with the railroad company or light rail transit agency should occur before work starts.
4. In the example depicted, the buffer space of the activity area should be extended upstream of the grade crossing (as shown) so that a queue created by the flagging operation will not extend across the grade crossing.
5. The DO NOT STOP ON TRACKS sign should be used on all approaches to a grade crossing within the limits of a TTC zone.

**Option:**

6. Flashing warning lights and/or flags may be used to call attention to the advance warning signs.
7. A BE PREPARED TO STOP sign may be added to the sign series.

**Guidance:**

8. When used, the BE PREPARED TO STOP sign should be located before the Flagger symbol sign.

**Standard:**

9. At night, flagger stations shall be illuminated, except in emergencies.

SECTION NO.	4100	DRAWING NO.	5.21
REV.D.			
<b>Traffic Control Typical Applications</b> - TA-46 -			
CITY OF FARGO ENGINEERING DEPARTMENT			
APPROVED JAD		DATE 1/2/2013	

## CITY OF FARGO SPECIFICATIONS TRAFFIC SIGNALS

### 1. GENERAL

This work shall consist of furnishing and installing traffic signals, pedestrian and school flashing beacons, communication cable, traffic surveillance cameras, and battery back-up systems. All work and material shall meet the National Electric Code, the North Dakota State Electrical Board, the local utility company, and the ordinances established by the City of Fargo. All materials shall be new unless specified otherwise in the Special Instructions for Bidders.

#### a. Traffic Signal Warranty

- i. The Contractor shall warrant and guarantee all materials, work, and equipment for a period of at least one year from the date of final acceptance. In addition, the controller equipment supplier and manufacturer shall provide an additional four-year warranty, for a total of five years on the EPAC controller. All manufacturer warranties and guarantees with respect to materials, parts, workmanship, or performance shall be secured and included with the shop drawing submittal.

#### b. Service Manuals

- i. The Engineer shall be furnished 1 service and operating manual for the traffic signal controller unit and emergency vehicle pre-emption controller.  
Each service manual shall include the following minimum information:
  1. Detailed description of operation and instructions for initial set-up
  2. All schematics and wiring diagrams of the unit
  3. Recommended servicing and service hints
  4. Complete parts list
  5. Recommended spare parts list

#### c. Coordination

- i. The Contractor shall coordinate all work with the City's project Engineer and/or inspector when work activities are scheduled. The Contractor is responsible to coordinate his activities with other City, State, or County work. If the Contractor determines that other work in the area will substantially affect the project's substantial completion date, it is his responsibility to notify the project Engineer and request a time extension.



- d. Location of Existing Utilities
    - i. Partial existing utilities have been shown to direct the Contractor's attention to their existence. Such utilities have been plotted from record drawings.
    - ii. The Contractor is cautioned that all existing utilities may not be shown. The location of existing utilities is not guaranteed, and the Contractor will be responsible for determining the exact location and protection of the existing utilities. The Contractor, before commencing any excavation or construction, shall find out the location and seek aid in locating all public and private utilities. The Contractor shall contact ND One-Call 1-800-795-0555 and request locates prior to beginning construction. Subcutting or scarifying over utility lines may be eliminated if, in the opinion of the Engineer, a hazardous situation exists.
    - iii. The Contractor is responsible for verifying and following minimum horizontal and vertical clearance between light and/or signal standards and overhead power lines.
  - e. Stop Sign Removal
    - i. Removal of existing stop signs prior to starting up the operation of a traffic signal shall be incidental to installing the traffic signal system.
2. TRAFFIC SIGNAL INITIAL AND FINAL INSPECTION AND SUBSTANTIAL COMPLETION
- a. The project will not be classified as substantially complete until the signal system is functional, including the completions of all pay items including a fully functional fiber optic communication system.
  - b. After the Contractor has completed the installation of the signal system(s) and any clean up items, he shall complete the "Contractor's Pre-Initial Traffic Signal Inspection Check List" provided by the City. Each item on the checklist shall be inspected by the Contractor. The Contractor's personnel that actually did the inspection shall initial each item showing that it has been completed. The completed check list shall be forwarded to the Engineer, along with the request for an initial inspection on the form provided by the City. The Engineer will set a date and time for the initial inspection. At the time of either an initial or final inspection, the Contractor is required to open and close all pull boxes, open and close all signal standard doors, and remove and hold wiring to allow for inspection of anchor bolt nut tightness with hammer test. Contractor shall be present within 10' of each item being inspected to ensure clarity on what needs to be corrected.
  - c. Initial and final inspections will not be performed between November 1<sup>st</sup> and April 1<sup>st</sup>. Inspections will not be done if there is rain or snow or wind greater than 15mph or if the temperature is less than 50° F.

- d. All items requiring additional work after the initial inspection will be noted by the City on the checklist. The Contractor shall complete work on all items prior to requesting a final inspection. A final functional inspection will be made a minimum of 30 more days after the initial inspection date. The Contractor shall submit, in writing to the Engineer, that all punch list items have been completed and request a final inspection on the form provided by the City. The Engineer or inspector may, at his discretion, stop the final inspection and require the Contractor to resubmit his request for final inspection after completing the required work. The City of Fargo will perform one initial inspection and one final inspection at no cost to the Contractor. Additional initial and final inspections shall assess the prime Contractor a fee of \$250 for each time an additional initial or final inspection is performed. The project will not be classified as final until the City accepts the project and assigns a final acceptance date. The date of final acceptance will be 30 days without failure for the City to accept the system. If the system fails during the 30-day acceptance period, the 30 days will start over after the failure has been repaired and inspected by the City. The Contractor is responsible for all maintenance of the signal system until the date of final acceptance, which includes being responsible for the system 24 hours a day, 365 days a year until the final acceptance date is reached.
3. SHOP DRAWINGS
- a. The Contractor shall provide an electronic PDF file of shop drawings and certifications required by the City of Fargo within 15 days after the contract has been signed by the City Commission. All shop drawings and certifications shall be approved prior to any work being started. The Contractor shall be responsible for the accuracy of the shop drawings. The Engineer's review does not relieve the Contractor of full responsibility for providing a quality product that meets Specifications.
- b. The Contractor shall submit shop drawings on the following listed items for approval:
- i. Traffic Signal Controller Cabinet
    1. Load Bay
    2. Siemens Eagle Controller
    3. EDI Conflict Monitor
    4. Voltage Surge Suppression
    5. Flash Transfer Power Relay
    6. Solid State Flasher
    7. Solid State Load Switches with Input and Output Indicators
    8. Detector Rack 2.4 AMP Power Supply
    9. Vehicle Detector Rack Card
    10. GTT Model 764 Opticom Phase Selector
    11. Ethernet Switch
    12. Audible Pedestrian Push Button System
  - ii. Battery Backup Cabinet
    1. UPS Power Module
    2. Batteries

3. Battery Charge Management System
4. Maintenance Bypass Switch
5. Signal Cabinet Circuit Breaker
- iii. Feed Point Cabinet
  1. Surge Protection
  2. Circuit Breaker
  3. # 6 Power Wire THW & RHW
- iv. EVP System
  1. Opticom Detector
  2. EVP Confirmation Light
  3. EVP Mounting Hardware
  4. Opticom Cable
- v. Fiber Communication
  1. Fiber Optic Cable
  2. Fiber Optic Pigtail
  3. Fan Out Kit
  4. Fiber Optic Connectors
  5. Fiber Optic Jumper Cables
  6. Fiber Optic Distribution Panel
  7. Fiber Optic Splice Cabinet
  8. Fiber Optic Tyco Splice Enclosure
  9. 4 Port Active Optical Star Coupler
- vi. Vehicle Heads
  1. Housing
  2. Back Plate
  3. LED Sections
  4. Mounting Hardware
  5. Visors
- vii. Pedestrian Heads
  1. Housing
  2. Visor
  3. LED section
  4. Mounting Hardware
- viii. Signal Standards
  1. Standard
  2. Mast Arm
  3. T-Base
  4. Anchor Bolts
  5. Bolts, Nuts, & Washers
  6. Luminaire Extension & Fixture
- ix. Pull Box
  1. Frame
  2. Cover

- x. Pedestrian Push Buttons
  - 1. Button
  - 2. Housing
  - 3. Sign
  - 4. Post
- xi. Detection Loops
  - 1. Loop Wire
  - 2. Loop Sealant
  - 3. Loop Lead-in
  - 4. Splice Kits
- xii. Conduit & Innerduct
- xiii. Signal Control Cables
  - 1. No.14 AWG 20
  - 2. No. 14 AWG 12
  - 3. No.14 AWG 7
  - 4. No.14 AWG 5
  - 5. No.14 AWG 3
  - 6. No.14 AWG 2
- xiv. Master Controller
- xv. Labeling Tape
- xvi. Camera Equipment
  - 1. Camera
  - 2. Mounting Hardware
  - 3. Power Supply
  - 4. Cables
  - 5. Ethernet Switch
  - 6. IMS 40-2 Cable(Iteries Video Detection)
- xvii. Interim Traffic Signal
  - 1. Wood Service Poles
  - 2. Vehicle Head Hardware
  - 3. Pedestrian Head Hardware
  - 4. Span Wire
  - 5. Guy Wire Anchors & Hardware
  - 6. Junction Boxes on Poles
  - 7. Weather Entrance Heads
  - 8. Span, Stabilization, & Guy Wire I-Bolts and Hardware
  - 9. 1" Ultratite-Type UL Liquid Tight Flexible Metal Conduit

#### 4. SIGNAL PAINT

The traffic signal system components shall be painted in accordance with the following:

- a. All new signal standards shall be painted with the Millerbernd Factory Finish Paint Coat Specification using the Millerbond I2/ZRU Paint System, with a clear top coat. Colors shall be as follows:

- i. Transformer base – gloss black
  - ii. Mast arm – yellow\* or gloss black (see plans)
  - iii. Signal head mounting hardware – yellow\* or gloss black (see plans)
  - iv. Shaft – yellow\* or gloss black (see plans)
  - v. Signal housing – yellow\* or gloss black (see plans)
  - vi. Pedestrian push-button post – yellow\* or gloss black (see plans)
  - vii. Pedestrian push-button housing – yellow\* or gloss black (see plans)
  - viii. Signal head doors, back plates and visors – flat black
- \*Yellow color shall be No.13538 of Federal Standard No. 595 B.*

- b. All areas requiring painting or touch up paint shall be prepared as follows:

- i. If rusted:

1. Completely remove all rust and loose paint.
2. Sand all painted areas with 40 to 100 grit paper, depending on conditions.
3. Wash down with “no rinse prepaint cleaner” manufactured by Great Lakes Laboratories.
4. Prime bare metal with Devran 205 Primer manufactured by Devoe high performance coatings, or an approved equal.
5. Top coat and clear coat with products supplied by the original pole manufacturer.

- ii. All other non-rust paint areas:

1. Remove loose paint.
2. Sand all paint areas with 40-grit paper.
3. Wash down with “no rinse prepaint cleaner”.
4. Prime bare metal with Devran 205 Primer manufactured by Devoe high performance coatings, or an approved equal.
5. Top coat and clear coat with products supplied by the original pole manufacturer.

- c. The following method shall be followed for re-painting existing Standards when required on the plan:
- i. Sandblast Signal Standard
    1. Remove all bandit mounting material, signs and pedestrian buttons.
    2. Completely remove all rust and paint by White Metal Blasting the signal standard.
    3. White Metal Blast cleaning is used when a totally cleaned surface is required. This method of cleaning is defined as a sandblasted cleaned surface with a gray-white uniform metallic color. It shall be free of all oil, grease, dirt, mill scale, rust, corrosion products, oxides, paint, stains, streaks or any other contaminant across 100% of every square inch.
    4. Sandblasting material shall be a steel grit angular carbon steel.
    5. Sandblasting shall be done on site with the signal standards in place and operational. All pedestrians and the traveling public shall be protected from all debris. All sandblasting material and removed pole paint/debris shall be collected in a method that is approved by the EPA. Existing pole paint-debris may contain harmful chemicals or existing lead paint, which the Contractor shall be responsible for containing and cleaning up, along with protecting pedestrians and the traveling public from these hazardous contaminates.
    6. Before the primer is applied the pole must be inspected by the City of Fargo to ensure that it is free of all paint, rust and contaminates. Pole must be prepped according to Specifications and to the satisfaction of the Engineer in the field. Pole may need to be re-blasted or may need to be cleaned with Devoe DEVPREP 88 cleaner. The Engineer in the field will require which method shall be used.
  - ii. Paint Signal Standard
    1. Mask all areas as per detail sheet in plans.
    2. Prime bare metal with Devoe Devran 205 Primer.
    3. Apply two top coats of Devthane 379UVA manufactured by Devoe high performance coatings, and one coat of clear coat as recommended by the top

coat manufacturer. *\*Yellow color shall be No.13538 of Federal Standard No. 595 B.*

4. Thickness of all coats applied shall be according to the manufacturer's recommended film thickness. Application of all materials shall follow the manufacturer's directions for use.
  5. Re-install all pedestrian push buttons and signs. Re-install iron pole plates for vehicle heads as per detail. Remove all masking.
  6. After sandblasting has been approved, clean all debris off terminal boards with compressed air, or stiff bristle broom. Apply coating of approved red insulation varnish to terminal block.
  7. Remove and replace ALL post mount plugs on standard before painting.
- iii. The Contractor shall warrant and guarantee all materials, work, and equipment for a period of at least five years from the date of final acceptance. Contractor is required to get a certified warranty from Devco to the City of Fargo covering all labor and materials if the paint fails. Cost of warranty shall be included with the price bid for "Paint Signal Standard".

## 5. PULL BOXES

### a. Install PVC Box (Detail 5.4)

- i. Pull boxes shall be PVC with metal frames and covers, and shall conform to the detail included in the plans.
- ii. Pull boxes in landscaped areas shall have the top of the box 0" to 1" above final grade and sloped to match the slope of the final grade on all 4 quadrants. Pull boxes in concrete area shall be set with the top of the box flush with the final grade at all 4 quadrants.
- iii. All PVC pull boxes installed in concrete areas shall have a bell end on the bottom of the pull box to prevent frost heaving.

### b. Install Fiber Pull Box (Detail 5.10)

- i. This shall include the cost to supply and install a polymer concrete pull box. The size shall be 30" x 48" x 48" deep, with no base. The cover will be 1-3/4" thick, secured with stainless steel bolts, and have a logo of "Traffic Signals". The base and cover shall be made of polymer concrete and sustain a minimum test load of 12,000#. Color shall be gray. Pull box shall be a PD style Quazite enclosure or approved equal that has a 1 degree flare to prevent frost heave.

- ii. Two feet of crushed rock shall be installed for drainage below the pull box and will extend 6" beyond the outside edge of pull box. The top of box shall be at final grade and sloped to match. A 6' x 6' concrete pad shall be installed around the IT-Pull box. The concrete pad shall be 6" thick, reinforced with 6" x 6" x 10 GA welded wire fabric and shall be incidental to the price bid for IT-Pull Box.

6. PEDESTRIAN PUSH BUTTON AND SIGNS (Detail 5.3)

- a. Pedestrian push button signs shall be bolted directly to the traffic signal standards. Do not use bandit for this purpose. Furnishing and installing pedestrian push buttons and sign shall be included with the price bid for TYPE IV, TYPE V, combo signal standard and pedestrian push button post and interim signal.
- b. All Pedestrian push buttons shall be a Polara EN2-EZ Communicator Navigator 2 wire push button system. All EZComm cabinet equipment shall be factory installed inside the cabinet by Brown Traffic products(included in Type B Cabinet). Pedestrian buttons shall have a 5" x 7 ¾" face plate with Braille options and a Bi-directional arrow. **One spare button shall be provided with each system.** The system shall include an "EZ Configurator" and the most current revision of software for installation on up to 10 computers.
- c. The pedestrian push button post steel post shall meet the requirements of the detail sheet. Pedestrian post base shall be schedule 80 extra heavy carbon steel black P.E. pipe O.D. 5.563" and wall thickness of .375". Pedestrian post shall be 4.5" Intermediate Metal Conduit.

7. FARGO TYPE B CABINET (Detail 5.3)

- a. The Cabinet size shall conform to the details shown in the plan and the following:
  - i. Type A Cabinet shall be size M (height 51", width 36", depth 17")
  - ii. Type B Cabinet shall be size P-44 (56" x 44" x 25.5")
- b. Anchor bolts must be set into controller foundation when poured.
- c. When installing the cabinet on the concrete foundation, a bead of SikaFlex 15LM construction sealant shall be placed under the bottom flange of the cabinet within one inch of the outside edge of the cabinet. An additional bead of SikaFlex 15LM construction sealant shall be placed continuously around the outside of the cabinet at the seam between the cabinet and the foundation. All exposed outer cabinet seams shall be sealed with a bead of SikaFlex 15LM construction sealant.



- d. The Contractor shall supply a fully wired and terminated NEMA cabinet from the pre-approved supplier list below. The controllers shall be supplied by the same manufacturer and be of the same model number and most recent software.
- e. City of Fargo Type B Cabinet Assembly with a MARC System, EPAC 3808 Model M-52 Series Controller with Fiber Optic Communications manufactured by Siemens, supplied by Brown Traffic Control, Davenport, IA. The conflict monitor shall be an EDI SSM 12LEip. All cabinets shall be wired for use of either 2 Channel or 4 Channel Global Traffic Technologies Opticom cards. The Contractor shall supply LM 602 Series rack mounted vehicle loop monitors from EDI of Phoenix, AZ. See plans for additional cabinet requirements.
- f. All new Fargo Type B cabinets shall have a Control RocketLinx ES8510-XT managed ethernet switch with 2 (SFP-MM-FX-XT) and 2 (SFP-SM10-GLX-XT) SFP's.
- g. OCC Fiber distribution enclosure. Standard is 2 ZDMB6B enclosures, one for singlemode fiber and one for multimode fiber. Adapter plates shall be 616DLC. Adapter plate may vary depending on the number of fibers to be landed in the signal cabinet. See fiber splice diagrams for details.
- h. Polara EN2-EZ Communicator Navigator 2 wire push button system which includes the Polara CCU2EN and interconnect board in the traffic signal cabinet.
- i. Cabinet Wiring Diagram
  - i. The following items shall be labeled on the Cabinet Wiring Diagram:
    - ii. The Loop Designation number (i.e. D2-1) from the plan shall be labeled on the Detector panel drawing adjacent to the point for termination.
    - iii. The field wire terminals for the Vehicle/Pedestrian Head Control Cables shall be labeled with the phase number and direction (i.e. 02, SB).
    - iv. The field wire terminals for the opticom cable shall be labeled with the pre-empt number (i.e. P.E. #1).
    - v. The field wire terminals for the pre-empt indicator lamps shall be labeled with the pre-empt number and direction (i.e. P.E. #1, N.B.).
    - vi. The field wire terminals for the pedestrian push button cables shall be labeled with the phase number (i.e. 08 PED).
    - vii. Provide an AutoCAD drawing file of the as-built cabinet wiring diagram.
    - viii. All text on the cabinet wiring diagram shall use the Arial style font.

- ix. The detector rack label shall look like the detector rack label on the plans. The text size shall be .13 in height for all text on the label except the VD1, SD1, VD2, SD2, etc. shall be .09 in height.
- x. Contractor is responsible for pickup of cabinet prints and for returning one revised print to the cabinet in the field and returning all other copies to the Sign and Signal shop, located at 510 5 St N.
- j. A complete cabinet conflict monitor test shall be performed and passed by the Contractor just prior to the uncovering of the traffic heads. The City will supply the conflict monitor maintenance record test form. The instructions on this form must be followed completely before the signals are used. Contractor is responsible to provide a flagger traffic control person for the intersection while the conflict monitor test is performed.
- k. The Contractor shall provide two spare load switches and one spare two-channel vehicle detector for each controller and cabinet supplied on the project.
- l. All load switches provided as part of this project shall be equipped with both input and output L.E.D.'s.
- m. Controller working slab shall be 6 feet wide and extend a minimum of 4 feet from the face of the controller foundation. The slab shall be 4 inches thick and reinforced with 6" x 6" x 10 GA welded wire fabric and shall be tied to the controller foundation with 18-inch long #3 rebar spaced 18 inches on center. The controller working slab shall have a slope of .25 inches per foot away from the controller cabinet foundation. The closest point of the top of the slab to finished grade shall be 2 inches above grade, except where matched to sidewalk grade. Working slab shall be incidental to pouring the controller cabinet foundation.
- n. The Contractor shall install two additional 2-inch diameter conduits in each new controller foundation. The direction of these conduits will be determined in the field by the Engineer and labeled in the cabinet by the Contractor. Each foundation for a traffic signal standard and each feed point foundation shall have one spare 2-inch conduit. The direction will be determined by the Engineer in the field and labeled at the foundation by the Contractor. The conduits shall be plugged with a 2" expandable pipe plug. Not a separate pay item, cost is to be included in the price bid for "Concrete Foundation Traffic Signal".
- o. The cabinet shall have a independent insulated multi wire terminal bar to terminate the trace wires installed in all signal conduits. A connection shall be installed to the trace wires terminal bar that can be accessed from the outside of cabinet for locating personnel.
- p. The Contractor shall label and provide to the City before installing the following equipment for programming:
  - Controller
  - Conflict Monitor
  - Fiber Switch w/ all accessories
  - PTZ Camera(Camera only)
  - EVP Card

8. VEHICLE AND PEDESTRIAN HEADS (Detail 5.2)

- a. All signal plumbizer and pedestal adapters/collars shall be steel – absolutely no aluminum.
- b. All vehicle heads and all pedestrian heads shall be SIG polycarbonate. All heads shall be installed level on all sides. Five section mast arm mounted heads shall be installed using an Astro bracket. All vehicle and pedestrian heads shall be manufactured by Siemens Eagle, McCain, or approved equal. All signal heads shall be required to have reinforcement plate kit installed on them.
- c. Astro brackets are approved for use on mast arm mounted 5-section heads. Astro brackets may also be used to mount new heads on existing mast arms that do not have an existing tendon on the mast arm. Shop drawings for signal heads shall indicate the type of mounting. All 5 section doghouse style heads shall have the doors hinge on outside of the head, so all heads can be opened at the same time.
- d. Vehicle Indication Alignment of Post and Pedestal Vehicle heads mounted on signal standards shall be leveled on all 4-sides and aimed to the center of the oncoming traffic lane 200 feet from the stop bar. Left turn heads that are post and pedestal mounted shall be aimed to the center of the left turn lane 100 feet from the stop bar. Mast arm heads shall be parallel to oncoming traffic.
- e. All traffic signal back plates shall be louvered aluminum and have a minimum thickness of .063". Back plates shall be installed using 3/4" O.D. x 3/16" I.D. x standard thickness washers on all screws. Washers shall be stainless steel #10 fender washers. Screws used to attach the back plates to the signal head shall be 1/2" #10 pan head tap screws supplied by Northern State Supply #TNP-4714-PZ or approved equal.
- f. All red, yellow, green and pedestrian indications shall be L.E.D. conforming to the latest standards of the Institute of Transportation Engineers. All LED's shall have a 5 year warranty. Approved 12" L.E.D. balls are Dialight "XL" series red ball part number 433-1210-003XL, yellow ball part number 433-3230-901XL, green ball part number 433-2270-001XL, or GE "GT1" series red ball part number DR6-RTFB-17A, yellow ball part number DR6-YTFB-17A-YX1, green ball part number DR6-GCFB-17A or Leotek "P2" series red ball part number TSL-12R-LX-IL6-A1-P2, yellow ball part number TSL-12Y-LX-IL6-A1-P2, green ball part number TSL-12G-LX-IL6-A1-P2.. Approved 12" L.E.D. arrows are Dialight red arrow part number 432-1314-001XOD, yellow arrow part number 431-3334-901XOD, and green arrow part number 432-2374-001XOD, or GE "GT1" series red arrow part number DR6-RTAAN-17A, yellow arrow part number DR6-YTAAN-17A-YX, green arrow part number DR6-GCAAN-17A, or Leotek "P2" series red arrow part number TSL-12RA-IL6-A1, yellow arrow part number TSL-12YA-IL6-A1, green arrow part number TSL-12GA-IL6-A1. Approved pedestrian heads shall be 16"x18" countdown pedestrian signals. Approved pedestrian countdown signals are GE "GT1" series part number PS7-CFF1-26A-J, or Leotek "CIL" series part number TSL-PED-16-CIL-P1, or approved equal. Dialight pedestrian countdown signals will NOT be approved

- g. Installing L.E.D. vehicle signal sections shall include furnishing and installing 12 inch L.E.D. vehicle signals existing signal head housing for the existing red, yellow, and green vehicle indications. The price bid shall include all materials and labor for each L.E.D. vehicle signal installed. Contractor is required to place an LED Load on any phase with a single LED when changing out the LED's to prevent the signal from going into flash. All LED lights shall have an insulated female quick disconnect on the termination wires. Contractor shall install a .250" x .032" male tab quick disconnect onto the signal head housing terminal block for quick connection.
  - h. Installing L.E.D. pedestrian signal sections shall include furnishing and installing 16" L.E.D. countdown pedestrian into the existing pedestrian signal head housing. The price bid shall include all materials and labor for each L.E.D. pedestrian signal installed.
9. VEHICLE DETECTION LOOPS (Detail 5.4)
- a. Sawed Vehicle loops shall be shown on the plans and the Loop Detector Detail Sheet. The loop location shall be marked on the pavement. The loop shall be placed in the lane for which it was intended, perpendicular to the lane, and to the size shown in the Contract. The Engineer may move the loop location longitudinally to avoid joints, pavement cracks, manholes, and other obstructions. All vehicle loops in milled areas shall be sawed after the surface has been milled and prior to the final lift of new asphalt.
  - b. Interruption of the normal flow of traffic shall be the minimum time necessary for installation of the road loop. Work shall not begin until all material, equipment, and personnel are at the site. Type III Barricades, warning signs, and flag persons shall be placed to protect the workers and the traveling public.
  - c. Conduit shall be installed from the pull box to the gutter or roadway edge as specified. Each loop shall have a separate conduit installed for the pull box entry. The excavation from the saw slot at the gutter or roadway edge shall be made by means of a punch or drill type tool, rather than by usual excavating methods. The visible portion of the gutter shall not be cut for conduit installation. The conduit shall be installed to directly receive the loop wire in line and not at an angle. The hole to receive the conduit shall be at a depth below the roadway surface so there is a minimum of 2 inches of cover on top of the conduit when installed. Duct Seal shall be inserted into the loop pipe to prevent any sealant from entering the pipe and the top 2 inches of the cover over the conduit hole shall be sealed with the same sealant used to close the saw cut. The conduit and the pull box shall be installed at the same time.
  - d. Only vehicle loop duct type wire shall be used having a ¼-inch XLPE high density polyethylene tube jacket covering a #14 AWG stranded copper conductor with Type XHHW insulation.
    - i. All sawed or preformed loops shall have 3 turns of loop wire.

## e. Loop Saw Lot

- i. The pavement slot shall be sawed with a self-propelled power saw equipped with a depth gauge and alignment guide. The pavement slot shall be cut cleanly and well defined. The saw cut shall be overlapped at all corners and right angle corners shall be cored as shown on the Standard Drawings. The saw cut may be made at any time before installation of the wire. Slots shall be cleaned immediately after the cutting operation.
- ii. All saw cuts shall be sealed with an approved hot pour sealant. Before sealing the saw slot, each saw slot shall be thoroughly dried, cleaned of all dust, dirt, concrete scale, and other foreign matter. Sandblast all sealed areas, and then blow out with a jet of compressed air to remove sandblasted materials. The joint faces shall be clean and dry when the joints are sealed. Joints shall not be sealed when the air temperature is below 40 degrees F.
- iii. Failure of the saw slot material in either adhesion or cohesion in the first year after the final acceptance date shall be cause for rejection and shall be repaired at the Contractor's expense.

## f. Hot Pour Sealant

- i. The heating kettle shall be of the indirect heating, double-boiler type, using oil or other suitable material as the heat transfer medium. The kettle shall have a thermostatically controlled heat source, accurate temperature indicating devices and an effective mechanical agitator.
- ii. The sealant shall have a pressure-type applicator and shall completely fill the saw slot from the bottom up to the top, until it is level with the road surface, with no more than 1/4" overflow or spillage of sealant onto the pavement surface. Tar buckets will no longer be allowed for application of sealant.
- iii. The sealant shall be W.R. Meadows 3405 hot-applied, single compont, polymeric joint seal compound, or an approved equal.

## g. Loop Lead-In Cables

- i. Loop lead-in cables shall be a #14 AWG stranded polyethylene insulated twisted pair with a foil shield with drain wire and a polyethylene jacket. The loop lead-in conductor shall not be spliced except at the pull box where this conductor and the loop conductor are spliced together.
- ii. Loop lead-in conductors shall be lightly sanded, cleaned with an approved method, and wiped clean with a clean towel, then wire nut or crimp connected, then encapsulated in an epoxy splice kit manufactured by URASEAL Product No. CK200B. Conductors in the splice kit shall not be taped together. Loop lead-in and loop wires shall have sufficient slack to extend a minimum of 6 feet above the pull box opening and installed in the pull

box with the splice kit taped to a length of 1" PVC such that the splice is secured in the upper 1/3 of pull box

h. Testing

- i. Before pouring the sealer, the loop shall be checked for continuity, inductance, and insulation resistance. The test shall be made in the Engineer's presence, and the necessary equipment needed to perform these tests shall be furnished by the Contractor. The City reserves the right to retest, and these test results shall govern the acceptance or rejection of the loop installation. Tests shall be made as follows:
  1. Continuity Test. Each loop detector circuit shall be tested for continuity at two locations:
    - i. Loop detector at the pull box before splicing with the loop detector lead-in cable shall have a value less than 0.5 ohms.
    - ii. Loop detector and lead-in cable system at the traffic signal controller cabinet or detector cabinet after splicing in the pull box shall have a value less than 5 ohms. The continuity test ohm reading at the traffic signal controller cabinet or detector cabinet shall be greater than the ohm reading measured at the loop detector at the pull box
  2. Inductance Test. Each loop detector and lead-in cable system shall have an inductance test measured at the traffic signal controller cabinet or detector cabinet. The inductance shall be in the range of 50 to 700 micro henries.
  3. Insulation Resistance Test. An insulation resistance test at 500 volts direct current shall be made at the traffic signal controller cabinet or at the detector cabinet between one loop detector lead-in conductor and the cabinet ground rod. The insulation resistance shall have a value of 500 mega ohms or greater.
- ii. A vehicle loop detector test shall be performed and recorded before the initial inspection using a City provided form. This form will be used for rechecking the loops at the final inspection.
- iii. The City will retest all loops at the Final Inspection.

10. CONTROL CABLES

- a. The jacket on all control cables shall be polyethylene with the thickness meeting Table 7.4.2 NEMA WC-70.

- b. All cables shall be un-spliced, including pedestrian push button wires.
- c. Terminal boards and blocks shall be provided for connections of control circuits in signal standard bases.
- d. There shall be no splices below grade except for loop lead-in conductors. Pulled through conductors shall have sufficient slack to extend a minimum of 18 inches above the pull box opening.
- e. Additional Cable Quantities
  - Additional cable quantities shall be installed to provide for slack and the wiring of controllers, feed points, and signal heads as follows:
    - A. Ten feet at the controller
    - B. Seventeen feet at post-mounted and pedestal-mounted vehicular signal heads
    - C. Fifteen feet at post-mounted and pedestal-mounted pedestrian signal heads
    - D. Eight feet at each pedestrian push button
    - E. Fifteen feet at each flashing beacon sign support
    - F. Twenty-three feet at each signal pole with mast arm plus the length of the mast arm, plus an additional 2' for plumbizer mount and an additional 5' for an Astro bracket mount.
    - G. Ten feet at the feed point
    - H. Five feet at each foundation for each incoming and outgoing pedestrian and signal head control circuit
    - I. Ten feet at pull boxes where connections are made.
    - J. Ten feet for loop lead-in cables where they are spliced to the loop in the pull box
    - K. Three feet at each foundation for each incoming and outgoing circuit which passes through the foundation with no connection being made.
    - L. 43 feet plus length of mastarm for Opticom and indicator light

#### 11. EMERGENCY VEHICLE PRE-EMPTION (Detail 5.5)

- a. All locations on the plans calling for an Emergency Vehicle Pre-emption Detector shall consist of a Global Traffic Technologies Model 722 EVP detector and light assembly. Install assembly 6 feet from end on existing mast arm poles unless otherwise shown on the mast arm detail sheet. Each detector tube shall be aimed at a point 1800' from the intersection towards the associated on-coming traffic. The indicator lamp shall be angled downward 1 notch from level and aimed at a point 1800 feet from the intersection.
- b. The Opticom Priority Control System shall be an Opticom Model 764 Multimode Phase Selector.
- c. Install EVP L.E.D. indicator lamps for all phases when new cabinet/EVP system is in place and operational.

- d. The Contractor shall notify the Fargo Fire Department when EVP is taken out of service and returned to service.
- e. The Contractor shall setup and verify the EVP detector operation within one week of the signal being operational to traffic. Contractor shall test range with a Contractor supplied EVP emitter at a distance of 1800' from the intersection. City will set the EVP range at the initial inspection.
- f. The EVP system shall be wired with an approved opticom cable that is recommended by the Manufacturer for the EVP detector.
  - i. Top Tube      Pre-emption    1 & 3 Blue Wire
  - ii. Bottom Tube    Pre-emption    2 & 4 Yellow Wire
- g. The Contractor shall follow Global Traffic Technologies instructions for all opticom cable connections. If only one circuit is needed, wire both tubes as assigned above. Cap the unused pre-empt opticom cable wire in the controller cabinet. Aim both tubes in the one direction that is being used.

## 12. CONDUIT

- a. All conduit shall be installed 24 inches below final grade. Nonmetallic conduit shall be either polyvinyl chloride (heavy wall – PVC) or high-density polyethylene (HDPE) conduit, both as specified below.
- b. PVC conduit shall meet the requirements of UL 651 suitable for direct burial applications and shall have a minimum wall thickness equivalent to Schedule 40 as defined by ASTM 1785.
- c. HDPE conduit shall meet the requirements of UL 651 and either ASTM 2447 or ASTM 3035 suitable for direct burial applications. HDPE conduit shall have a minimum wall thickness equivalent to Schedule 40 as defined by ASTM 2447 or DR 15.5 as defined by ASTM 3035. HDPE conduit shall be install 24" below finished grade and shall not be installed when either the conduit temperature or ambient temperature is below –10 F. HDPE conduit used for signal wire conduit runs must be RED in color, and HDPE conduit runs for fiber/comm., must be ORANGE in color.
- d. Conduit shall be installed at the location shown on the plans. Conduit shall be bored under existing pavement. Boring conduit shall be considered incidental to the bid price for conduit and for which no additional compensation shall be made.
- e. All conduits shall have bell ends installed on both ends of the conduit run.
- f. All conduits containing conductor/cables shall be sealed with duct seal at the controller cabinet and at the traffic signal standard foundations.
- g. All spare conduits shall be plugged with an expanding rubber pipe plug and labeled at the cabinet and signal standard bases.



- h. PVC and HDPE conduit will be measured by the linear foot. Couplings/fittings used at concrete bases, and the method of innerduct installation, will not be measured for payment but will be included in the price bid for conduit. Contractors shall install two additional 2-inch diameter conduits in each new controller foundation. The direction of these conduits will be determined in the field by the Engineer and labeled in the cabinet by the Contractor. Each foundation for a traffic signal standard and each feed point foundation shall have one spare 2-inch conduit. The direction will be determined by the Engineer in the field and labeled at the foundation by the Contractor. The conduits shall be plugged with a 2" expandable pipe plug. Not a separate pay item, cost is to be included in the price bid for "Concrete Foundation Traffic Signal".
- i. All conduits shall have a No. 12 Duratrace Copper Clap tarce wire installed including empty/spare.

### 13. LABEL ALL FIELD CABLES

- a. All labeling materials shall be approved by the City. Labels shall be readable without moving the cables. All field cables installed by the Contractor shall be labeled with the cable designations:

TYPE	LABEL	LABEL LOCATION
Communication cable	Comm./intersection address of other end	Within 12" of conduit
Pedestrian push button	Phase/location (i.e. 02-NW, 02-SW, 02-S MED, etc.)	Within 6" of terminals
Loop lead-in	Detection zone (i.e. D2-1, D2-2, etc.)	Within 6" of terminals
Control cable	Cable number & location (i.e. Cable 1-NW, Cable 2-SW, etc.)	Within 12" of conduit
Opticom cable	Pre-empt number/location (i.e. P.E. 1-NW, P.E. 2-SW, etc.)	Within 6" of terminal
Camera power cable	Camera no./location (i.e. camera 1/NW)	Within 6" of terminal
CAT 5 cable	Camera no./location (i.e. camera 1/NW)	Within 6" of terminal
Head Cabinet Controller Wires	Tie the RED-YELLOW-GREEN wires together with electrical tape for each cable head and label with the plan head number (i.e. Head #1, Head #2, P1, P2)	Within 6" of terminal

- b. All labels shall be machine printed on a tape width of 3/4". All lettering shall be minimum 3/8" uppercase block style letters. The tape shall be affixed around the perimeter of cable with the tail at 90° to the cable. All lettering shall be on the tail of the label and readable without moving the cables. The labeling tape shall be designed for outdoor use. The tape shall have a minimum outdoor durability rating of 5 years in temperature ranging from 180°F to -40°F. The labels shall be capable of being applied outdoors at temperatures as low as 0°F.

14. COMMUNICATION CABLE (Detail 5.10)

The communication cable shall be a 24 strand fiber multi-mode/84 strand single mode hybrid optic cable suitable for outside plant operations manufactured by Superior Essex. The cable shall be a loose tube, single jacket, all dielectric cable design. The buffer tubes shall be gel filled, and the cable shall have a dielectric central strength member and a dry water blocking system. Tube colors shall be multi-mode blue tube fibers 1-12, multi-mode orange tube fibers 13-24, single-mode green tube fibers 25-36, single-mode brown tube fibers 37-48, single-mode slate tube fibers 49-60, single-mode white tube fibers 61-72, single-mode red tube fibers 73-84, single-mode black tube fibers 85-96, and single-mode yellow tube 97-108.

FIBER OPTIC CABLE REQUIREMENTS		
Requirement	Multi-mode	Single Mode
Outer Jacket	Polyethylene	Polyethylene
Core Diameter ( $\mu\text{m}$ )	62.5	8.0 – 10.0
Clad Diameter ( $\mu\text{m}$ )	125	125
Max. Attenuation ( $\text{db}/\text{km}$ )	3.5 @850 nm 1.0 @1300 nm	0.35 @1310 nm 0.25 @1550 nm
Min. Bandwidth ( $\text{MHZ}/\text{km}$ )	160 @850 nm 500 @1300 nm	N/A N/A
Max. Tensile Loading (N)	2700 Short Term 600 Long Term	2700 Short Term 600 Long Term

## a. Fiber Optic Cable

- i. The fiber optic cable shall be dual window single-mode fiber with a maximum attenuation of 0.4 db/km at 1310 wavelength and maximum attenuation of 0.3 db/km at 1550 wavelength and shall meet or exceed Ethernet transmission standard IEEE 802.3ae.
- ii. Fiber cable construction shall be loose tube gel-filled color-coding per TIA/EIA 598B standards. The Central Strength member shall contain no metallic conductors. The overall strength member shall be aramid fiber yarn or fiberglass; the inner jacket shall be black UV and moisture resistant PE. The outer jacket will be black UV and moisture resistant PE with sequential meter markings.
- iii. The item “Communication Cable” will be measured by the linear foot. The quantities measured will be paid for at the contract price and shall be full compensation for all labor, equipment, and material necessary to complete the installation of the communication cable.

- iv. Fiber optic cable insulation shall have a maximum tensile load of 600 lbs. for installation and 200 lbs. for in-service load. The minimum bend radius shall be 20XOD for installation and 10XOD for in-service.

b. Handling of Cable

- i. Cables or conduit shall be carefully inspected by the Contractor during placement operation to be certain that the fiber optic cable and conduit are free from damage before placement.
- ii. Bends of small radiuses and/or twists that might damage cable or wire shall be avoided. During the placement operation, fiber optic cable shall not be bent in a radius less than 20 times the outside diameter of the cable.
- iii. Care is to be exercised during the placing operation, to feed the cable into the inner duct loosely and at no tension. Equipment and construction methods shall be such as to assure compliance with this requirement. The Contractor shall furnish competent supervision at all times at the site of cable placing operations to assure compliance with this requirement.
- iv. Every instance of damaged cable or wire observed at any time whether prior to installation, occurring during construction, or discovered by test of observation subsequent to installation in plant, shall be immediately called to the attention of the Engineer. The method of repair or correction of such damage shall be in accordance with the written instructions of the Engineer. The Contractor shall promptly repair such damage or make such corrections in accordance with such written instruction of the Engineer. Minor damage to the outer jacket of the cable or wire observed prior to or occurring during construction shall be repaired in accordance with RUS Splicing Standard Bulletin 1753F-401 (PC-2).
- v. The Contractor shall use a break-away swivel rated for 600 lb. break load for pulling all fiber optic cables.

c. Miscellaneous Specifications

- i. The Contractor shall include a No. 12 Duratrace Copper Clad Trace Wire running the full length and parallel to each communication cable installed in conduits as a trace wire. This is not a separate bid item. The cost shall be included in the price bid for communication cable. The trace wire shall be labeled with the intersection address that it connects to. If the distance is too long to have a trace wire un-spliced then the Contractor may splice the trace wire in a pullbox with a DuraTrace connector part #3WY-01 or 3WB-01.
- ii. The Contractor shall provide 30' of slack cable in each pull box and 150' slack for each cable at the cabinet pull box where termination or splicing will occur or 85' of slack if the

fiber cable is completely cut and is the end of the fiber run. The Contractor shall remove 10' of each cable end that was used to pull cable prior to installing the required amount of slack to be left in the pull box. Contractor is required to contact the Engineer in the field to discuss all footages left in pull boxes and what is needed for splicing before pulling in fiber and cutting it.

d. Fiber Optic Terminations And Equipment

The price bid for Fiber Optic Terminations and Equipment shall include all necessary connectors, terminations, equipment, labor and all other miscellaneous material to install a fully functional communication system including, but not limited to, the following:

- i. Supply and install a MM and/or SM fiber optic pigtail that, shall be an OCC LC12XBX8A-0100 SM ASSEMBLY W/BX 12F with yellow outer jacket for single-mode, and LCC12XBX8A-0100 MM ASSEMBLY W/BX 12F with orange outer jacket for multi-mode, with a 2.0mm subcable around each fiber strand or approved equal. All ends of the pigtail shall be factory installed.
- ii. All installed connectors and fusion splicing.
- iii. Supplying and installing all OCC fiber optic distribution panels as per plan sheet.
  1. OCC Fiber distribution enclosure. Standard is 2 ZDMB6B enclosures, one for singlemode fiber and one for multimode fiber. Adapter plates shall be 616DLC. Adapter plate may vary depending on the number of fibers to be landed in the signal cabinet. See fiber splice diagrams for details.
  2. Distribution panel labels shall be labeled with the intersection address of the cable's other end, the port group as shown on the detail, and the number of the fiber strand terminated, and placed on the face of the distribution panel adjacent to the cable's six fiber ports
- iv. Providing and installing all fiber optic jumpers.
  1. Fiber optic jumpers attached to the distribution panel should be labeled with the fiber # it's connected to for each port group, representing the port it's plugged into. Fiber jumpers attached to the EPAC and MARC controllers shall be labeled A Tx/Rx or B Tx/Rx, representing the port it's plugged into.
- v. Providing and installing TYCO FOSC 450 D6 enclosures and splice trays as per plan sheet.
- vi. Providing and installing any international fiber systems four port active optical star coupler part #DT4010 as per plan.

- vii. Any managed Ethernet switches that are called out for on the fiber splice diagram.
  - viii. Labeling all fiber cables, fiber tubes, trace wires, fiber pigtails, fiber distribution panels, fiber scalability centers, fibers jumpers, and all individual terminated fibers.
- e. Fiber Optic Cable Testing
- i. The Contractor shall test all terminated fibers at both ends with an OTDR tester and light meter recording the results on a City of Fargo Fiber Test Report Form and providing a computer printout from the OTDR of each fiber tested. If multi-mode fiber tests at 850 NM and 1300 NM are not within the City of Fargo standards of .5 dB loss for each ST connector at the bulkhead, .2 dB loss for each fusion splice, and .1 dB loss per 100 feet for 850 NM and .1 dB loss per 300 feet for 1300 NM of fiber being tested, then the Contractor shall repair/replace and the Contractor shall re-test the fiber with City personnel present. If single-mode fiber tests at 1310 NM and 1550 NM are not within the City of Fargo standards of .5 dB loss for each ST connector at the bulkhead, .2 dB loss for each fusion splice, .1 dB loss per 600 feet for 1310 NM and .1 dB loss per 750 feet for 1550 NM of fiber being tested, then the Contractor shall repair/replace and the Contractor shall re-test the fiber with City personnel present. All fiber shall be tested at each end. Any terminated fiber run that doesn't meet the testing tolerances specified shall be repaired/replaced by the Contractor. If any connectors or fusion splices fail the Contractor shall repair the connection, if a fiber cable is damaged or broke between connections the Contractor shall replace the entire cable between connections.
  - ii. Single mode fiber when tested shall be allowed the following tolerances: .1 dB per 600' (1310nm), .1 dB per 750' (1550nm) of fiber, .2 dB for each fusion splice, .5 dB for each ST connector, and .5 dB for each end that is bare fiber tested.
  - iii. Multi-mode fiber when tested shall be allowed the following tolerances: .1 dB per 100' (850nm), .1 dB per 300' (1300nm) of fiber, .2 dB for each fusion splice, .5 dB for each ST connector, and .5 dB for each end that is bare fiber tested.
  - iv. All fiber optic cable that is removed shall be tested by the Contractor and documented after it is removed and placed on a wire spool. All existing fiber optic cable will be considered good and meeting City of Fargo tolerance Specifications. If the existing fiber tested doesn't fall within the tolerance of the specification, then the Contractor shall replace the fiber optic cable with a new one. The Contractor may test the existing cable before it is removed with an OTDR or light meter and provide a computer print out of the testing results to the City of Fargo, to ensure that the existing cable is good and meets specification tolerances.
- f. When all terminations are complete, the City of Fargo must inspect all splices inside the TYCO FOSC enclosures before the fiber optic communication system can be put into use. Contractor must set up a time to have the cases inspected, Contractor must open splice cases and show all

splices and fiber tubes inside the TYCO splice case to the Engineer in the field. All fiber tubes shall be labeled inside the splice enclosure.

## 15. REMOVAL OF TRAFFIC SIGNAL EQUIPMENT

### a. Remove and Salvage Traffic Signal Equipment

i. This item includes the removal and salvage of all above ground and removal and disposal of all unused below ground conduit and pull boxes. All salvaged material shall be delivered by the Contractor to a City storage facility as directed by the Engineer. All salvage material shall be protected by the Contractor, and materials that are damaged by the Contractor's removal process or mishandling, shall be replaced with new equipment at the Contractor's expense. Before removing existing equipment, arrangements shall be made for the local utility company to disconnect the power source. When the meter is no longer needed, the local utility will remove it. The Contractor shall disconnect all wiring to the equipment and completely remove the item from its foundation. The traffic signal heads, and mounting brackets shall be removed from the standards, and the signal heads shall be removed from the mounting brackets. The old traffic control cabinet concrete foundation shall not be salvaged.

### ii. Remove and Salvage Signal Standard

1. All signal standards removed from the project shall become property of the City of Fargo. Signal standards and mast arms shall be delivered to the City of Fargo Pole Lot for storage or taken to Gerdau Ameristeel/Fargo Iron and Metal for metal scrap salvage, and a check written to City of Fargo Traffic Engineering for the amount issued for the signal standard scrap metal. The signal poles that will be scrapped are to be determined by the Engineer in the field. All costs for removing and salvaging signal standards shall be incidental to the price bid for remove and salvage signal equipment.

### iii. Remove Interim Traffic Signals.

1. Feed point equipment shall be removed from the service pole. The conductor to the signal heads and controller shall be disconnected and removed, and all equipment on the service poles shall be removed. The service poles, span wire, and stabilization wire shall be removed and stored as directed.

### iv. Remove Traffic Signal Controller.

1. The controller cabinet and all controller equipment shall be removed for storage. The foundation shall be removed and the surface of the site restored.

- b. Remove Traffic Signal Foundation
  - i. The existing foundations shall be removed to a depth of 4 feet below the ground line and the surface restored to match adjacent areas.
- c. Remove and Salvage Conductor
  - i. This item covers the disconnection of all wires, removal and salvage of all wire from intersection. Delivery of all salvaged wire to a facility designated by the City of Fargo.
- d. Remove Pull Box
  - i. The old concrete pull boxes shall not be salvaged; they shall be disposed of by the Contractor. All PVC pull boxes, frames and covers shall be salvaged and delivered to a facility designated by the City of Fargo.

16. INSTALL INTERIM SIGNAL (Detail 5.8)

This item includes the cost of providing, installing and maintaining interim signals at the location shown on the plans. All equipment supplied by the Contractor shall meet the City of Fargo Specifications. The Contractor shall install a pole mounted feed point and is responsible for arranging electrical service to the interim signals. All costs associated with the feed point shall be incidental to the price bid for interim signal. The Contractor will be responsible for the maintenance and electricity costs for the interim signal until the date of final acceptance.

- a. Contractor shall provide the following items for the interim signal; items shall be incidental to the price bid for "Install Interim Signal".
  - i. Span wire
  - ii. Guy wire and anchors
  - iii. Conduit
  - iv. Wire
  - v. Weather entrance leads
  - vi. Junction boxes on interim poles
  - vii. Span and stabilization wire eye bolts
  - viii. Pedestrian push buttons and signs
  - ix. Pole mounted feed point
  - x. All 16" x 18" countdown Pedestrian Heads and mounting hardware
  - xi. All vehicle heads and mounting hardware
  - xii. Class II wood service poles
  - xiii. Traffic signal controller cabinet and controller with all pluggable.

17. FEED POINT (Detail 5.3)

- a. All conduits, cabinets, service conductor, service entrance heads, meter sockets (if required), and ground rods shall be furnished by the Contractor. All equipment mounted in a switch box of the size shown on the Plans shall be arranged, installed, and wired as required. The local utility company shall be contacted for specific locations of feed points. The utility company will furnish and install the required single phase voltage service connection and any required meter. The contractor is responsible for ALL coordination and costs involved with getting power to the feed point.
- b. All traffic signal or combination traffic signal/street light feed points shall be pad mounted. The cabinet shall be NEMA 3R rating with lock drip shield and a 10 gauge steel back panel with ½” spacer behind the panel. The panel shall be painted white. The cabinet shall be constructed of welded, anodized Duranodiz 311 finished aluminum or stainless steel, minimum .125 thick, with non-corroding hardware. The minimum size shall be 60” high, 27” wide, 14” deep, (larger size may be required based on number of street light circuits) with a 3-point latch pad lockable handle. Cabinet shall be weatherproof. Padlock shall be obtained from the City of Fargo Engineering Department. The Electrical Company may require 2 electrical meters; 1 for traffic signals and 1 for street lights. This shall be incidental to the price bid for “Feed Point”. Feed points shall require two ground rods that are spaced 6’ to 7’ apart.
- c. A lightning protection device shall be installed on the feed point incoming lines to prevent lightning surges entering through the wiring from damaging electrical wiring and control equipment in the traffic controller cabinets. The protector shall be a sturdy, weatherproof, service-proven device that immediately drains lightning surges harmlessly to ground. The protector shall be installed on the switch box and shall discharge a surge in a fraction of a second. It shall perform this protective function over and over again, without any maintenance required; possessing the same long-life, value-type characteristics obtained in higher voltage distribution arrestors. The protector shall be a two-pole, three-wire device designed for single-phase 120/240 volt three-wire grounded neutral service. The protector shall be mounted in the knockout in the switch box. All leads shall be tinned copper No. 14 AWG. The protector shall be capable of:
  - i. Limiting the surge voltage to 3 KV peak, while;
  - ii. Conducting surge currents of at least 10 KA with an 8 by 20 microseconds (time to crest by time to second half-crest) waveform; and Recovering to its former state after the surge is over with AC power applied. The manufacturer of the AC suppressor shall certify that the suppressor meets ANSI C 621.1/IEEE, Standard 28, paragraphs 7.1 and 7.6. The suppressor peak voltage shall not exceed 3 KV when tested according to paragraphs 7.3 and 7.5 of the ANSI/IEEE Specification. The AC line surge protector shall be installed on the load side of the circuit breaker. If the protector should fail and short the circuit, the circuit breaker shall open to give maximum protection. The AC neutral shall have the same protection as the AC load. The arrester leads shall be kept as short as possible. Grounds shall be made directly to the cabinet wall or ground plate as near as possible to the object being grounded. An acceptable arrangement is shown on the Plans. If the AC



power is brought into the cabinet via an underground conduit, a similar arrangement shall be followed as shown on the Plans. If the conduit is metallic, it shall be connected to the ground rod as shown on the Plans. Connections from the ground rod to the objects inside shall be made with AWG No. 8 (or larger) copper wire.

#### 18. BATTERY BACKUP SYSTEM

The cost bid for this item shall include all of the equipment listed below, any miscellaneous hardware, and installation of the UPS.

##### a. UPS Equipment and Hardware

Qty.	Part Number & Description	Item #
1	Novus FXM 1100 with optional SNMP Ethernet Interface	017-201-21
1	MBP - 20 Amp (bypass transfer switch)	017-183-24
4	AlphaCell 195 GXL - 5 Yr Warranty - 100Ah	195 GXL-5
1	48V ALPHAGuard	012-302-21
1	8' Cables - 33,160,165,180,210 - FXM	875-596-21
1	41H24W16D (Southern Quote JR-469) revised (Cabinet)	New Part
1	30A Circuit breaker and mounting hardware	QOU130

Qty.	Part Number & Description	
4	3/8" x 2" bolts with nuts and lock washers	used to mount UPS cabinet
8	3/8" X 1 5/8"x 1/4" heavy square washers	used to mount UPS cabinet
4	1/4" spring nuts and 1/4" X 1/2" screws	used to mount Bypass Transfer Switch
1	2" chase nipple, lock nut and plastic bushing	
2	1 1/2" x 23" Telespar	used to space up the lower shelf

Qty.	Part Number & Description
unit	#10AWG solid blue, white and green power wires
unit	#18 AWG stranded black for logic common, yellow and orange control wires
3	#18 AWG #8 stud crimp lugs
unit	silver silicone caulk

- b. UPS Install Instructions
- i. City will program the UPS controller.
  - ii. Attach, the UPS cabinet to the signal cabinet 4" up from the top of the signal cabinet cement foundation, using 4-bolts, nuts and 8-large square washers. Drill mounting holes through the UPS cabinet reinforcement plates about 3/4" from the cabinet sides. Silver silicone caulk the top and sides of the UPS cabinet where it meets the signal cabinet.
  - iii. Install top of top shelf 31" from bottom of UPS cabinet and top of the center shelf 16 1/2" from bottom of UPS cabinet. Install the bottom shelf on top of the Telespar spacers.
  - iv. Install a 2" steel chase nipple and plastic bushing directly below the top shelf of the UPS cabinet into the signal cabinet.
  - v. Install the following equipment in the UPS cabinet and wire per the plan wiring instructions and drawings:
    1. Place the UPS control unit on the top shelf.
    2. Place left to right batteries #1 & #2 on the middle shelf.
    3. Place left to right Alpha Guard and batteries #3 & #4 on the bottom shelf.
  - vi. Install and wire the UPS transfer switch in the signal cabinet on the mounting channels above the power panel.
  - vii. The existing traffic signal cabinet power panel will need modifications to comply with the plan's wiring drawing. Below is a written description:
    1. Install circuit breaker CP4.
    2. Remove feed wire from CP3 and install to CP4.
    3. Remove feed jumper from between CP1 and CP2
    4. Remove feed wire from CP2 and install to CP1.
    5. Install Jumper between CP2 and CP3.
  - viii. Verify the operation of the equipment by exercising the transfer switch to all positions and test for the appropriate 120 voltages on the terminals of the transfer switch, UPS and signal cabinet power panel.
- c. The City of Fargo shall supply a typical wiring diagram showing how the battery backup system shall be installed in the traffic signal cabinet. Contractor is responsible for redlining and providing 3 copies of the Brown Traffic Products AutoCAD revisions of the traffic signal cabinet wiring diagram. Contractor is responsible for pickup of cabinet prints and for returning one revised print

to the cabinet in the field and returning all other copies to the sign and signal shop. All costs associated with this shall be included in the cost bid for "Battery Backup System".

- d. The Contractor will provide all traffic control for this project.

19. SIGNAL STANDARDS (Detail5.2)

a. City of Fargo Provided

- i. The City of Fargo will provide all new Type IV, Type V, and Type VI signal standards. The standards, T-Bases and anchor bolts have been ordered from Millerbernd Manufacturing, Winsted, MN. All signal standards with a mast arm length of 40' or greater shall be built according to Fatigue Category II ND DOT standards. The Contractor is responsible for unloading, storage and transporting of the standards from the time of delivery until installation. The City will inspect the standards upon delivery from the manufacturer. Any damage to the signal standards, T-Bases, or anchor bolts after the date of delivery and acceptance by the City will be the Contractor's responsibility to repair or replace as directed by the Engineer.
- ii. The cost bid for this item shall include unloading, storage, transportation, installation, miscellaneous hardware, installation of all signage, providing and installing all pedestrian buttons and signs, etc. The luminaire is included in the street lighting section.

b. Contractor Provided

- i. The Contractor will provide all new Combo, Type IV, Type V, and Type VI signal standards. The standards, T-Bases and anchor bolts shall be ordered from Millerbernd Manufacturing, Winsted, MN. All signal standards with a mast arm length of 40' or greater shall be built according to Fatigue Category II ND DOT standards. The Contractor is responsible for unloading, storage and transporting of the standards from the time of delivery until installation. Any damage to the signal standards, T-Bases, or anchor bolts will be the Contractor's responsibility to repair or replace as directed by the Engineer.
- ii. The cost bid for this item shall include providing unloading, storage, transportation, installation, miscellaneous hardware, installation of all signage, providing and installing all pedestrian buttons and signs, etc.
- iii. All signal poles shall be Contractor provided unless otherwise noted on the signal plan.

- c. Signal Standard Signs (Detail 5.5)
  - i. Furnishing and installing mast arm and signal standard signs on new signal standards is considered incidental to the bid price for all types of combo and signal standards for which no direct compensation will be made.
  - ii. All mast arm mounted street designation signs shall utilize 18" 100 gauge flat aluminum, 48" or longer, depending on the space needed.
  - iii. The signs shall have modified "E" series letters with a 12" upper and 9" lower case format and a 1" sign border. The superscripts shall be 6" (half size) capital letters and will line up with the top of the other letters and numbers.
  - iv. The sign sheeting shall be 3M H.I.P. sheeting, and any processed colors, inks, or electronic cuttable film shall be a matched component system.
- d. Signal and pedestrian standard transformer bases shall have Xcluder Fill Fabric placed continuously around the inside of the lower plate to prevent rodents from accessing the base through space between concrete foundation and the lower plate. The fabric shall be secured to the anchor bolts.
- e. Wire entrance fittings shall be provided by the Contractor. Fittings should be a Fernco or approved equal rubber sleeve with clamps to protect the wire through the wire entrances on each signal standard upright. The cost to supply and install the protected rubber sleeves shall be incidental to the price bid for the signal standard.
- f. All standards shall be plumbed with leveling nuts. The hand hole shall be located away from traffic and the mast arms shall be perpendicular to the roadway centerline.
- g. The anchor bolts shall be installed and tightened as specified on detail sheet and according to the manufacturer's recommendation.
- h. Spliced or pulled through conductors shall have sufficient slack to extend a minimum of 18 inches outside of the enclosure.
- i. Terminal blocks in signal standard bases shall be attached to a plastic plate with the minimum thickness of 3/8". The plate shall be 2" larger than the terminal block on all sides. The termination shall be coated with red insulating varnish with a dielectric strength of 2100 volts/mil. The varnish shall be applied immediately after the terminations have been made. The terminal block shall face termination side face down in the transformer base.

## 20. REVISE CONTROLLER AND CABINET

- a. The price bid shall include all material and labor to upgrade the existing controller and cabinet.

- b. The work at each location is listed on the plan sheet.

## 21. TRAFFIC SIGNAL SHUT DOWN

### a. Signing Requirements

When a signal is taken out of operation, the Contractor is required to install a 36" x 36" "Signal Out Ahead" sign, a 24" x 30" R2-1 25mph speed limit sign, and 36" x 36" W20-7 "Flagger Ahead" sign. Contractor shall install 2 STOP signs for each direction of travel when signal is down.

### b. Other Requirements

The Contractor shall contact the City of Fargo Sign and Signal Shop at 241-1440 and notify them that the signal is going to be taken out of service. The Contractor shall not be allowed to take the signal out of operation between the hours of 7am to 8:30am, 11am to 1pm, and from 4pm to 6pm. The Contractor shall shut down the traffic signal only during off peak hours as approved by the Engineer in the field. The Contractor shall provide two flaggers and have then control the intersection while the traffic signal is not in operation. All flagging activities and equipment shall conform to the standards set forth in the current version of the Manual on Uniform Traffic Control Devices, published by the FHWA.

## 22. SOLAR SCHOOL FLASHING BEACON (Detail 5.7)

- a. School flashing beacon shall be a solar school zone flasher manufactured by RTC Manufacturing, Inc. Each solar school zone flasher shall include the following items:
  - i. Combination flasher/battery cabinet with #2 Corbin lock and ubolt mounting for 4½" O.D. pole.
  - ii. Wired back panel w/toggle switch and volt/current meter AECA (PR 1010).
  - iii. DCF2 two circuit 12 VDC flasher.
  - iv. CPR2102 pager programmable time switch.
  - v. 2 – 12' yellow 12 VDC LED's.
  - vi. 60 watt solar panel
  - vii. 1 – 100 amp hour gel cell battery.

- viii. 15' Schedule 80 spun aluminum pole with T-base and anchor bolts.
  - ix. 2 – 12" federal yellow aluminum signals with visors and mounting brackets.
  - x. PR1010 volt/current meter.
  - xi. DCF2 12 VDC flasher.
  - xii. All signs shown on the detail sheet (S5-1).
- b. The cost bid for this item shall include all of the above listed equipment, all of the items shown on the solar school zone detail sheet, any miscellaneous hardware, 24" diameter foundations 4' in depth, and installation of the school flashing beacon.
  - c. Four (4) anchor bolt plates shall be installed for all solar school zone flashers.
  - d. Beacon heads mounted on the solar school zone flashers shall be leveled on all 4-sides and aimed to the center of the oncoming traffic lane 200 feet from the School Flasher.

23. PEDESTRIAN FLASHING BEACON ASSEMBLY (Detail 5.6)

- a. Controller Cabinet and Assembly
  - i. The Contractor shall supply a fully wired and terminated ND Fargo PB Activated Flasher w/HOA Switch manufactured by Brown Traffic Products with a flashing circuit panel, general purpose relay, flasher relay and multifunction time delay relay. Cabinet shall have its own 15 AMP circuit breaker. Cabinet dimensions shall 36"H x 20"W x 15"D. When installing the flasher cabinet onto an existing cabinet, a bead of high quality silver silicone caulk shall be placed completely around the flasher cabinet where it is attached to an existing cabinet.
- b. Flasher Equipment
  - i. All beacon head mounting hardware, pedestal adapters/collars shall be steel – absolutely no aluminum.
  - ii. All beacon heads shall be SIG polycarbonate and installed level on all sides. All beacon heads shall be manufactured by Siemens Eagle.
  - iii. Yellow indications shall be L.E.D. signal heads manufactured by Dialight, GEL core or approved equal, conforming to the latest standards of the Institute of Transportation Engineers. Approved 12" L.E.D. yellow balls are Dialight "XL" series yellow ball part number 433-3230-901XL. GEL core "GTx" series, yellow ball model number DR6-YTFB-77A.

## c. Additional Conduit

- i. The Contractor shall install two additional 2-inch diameter conduits in each new controller foundation. The direction of these conduits will be determined in the field by the Engineer and labeled in the cabinet by the Contractor. Each foundation for a Type V pedestrian flasher and each feed point foundation shall have one spare 2-inch conduit. The direction will be determined by the Engineer in the field and labeled at the foundation by the Contractor. The conduits shall be plugged with a 2" expandable pipe plug.

## d. Anchor Bolt Plate

- i. Four (4) anchor bolt plates shall be provided for all 4-inch signal standards. See detail.

## e. Beacon Indication Alignment

- i. Type V pedestrian beacon heads mounted on 4" signal standards shall be leveled on all 4-sides and aimed to the center of the oncoming traffic lane 200 feet from the pedestrian crosswalk.

## f. Cabinet Wiring Diagram

- i. The following items shall be labeled on the Cabinet Wiring Diagram:
  1. The field wire terminals for the Beacon Head Control Cables shall be labeled with the direction (NB, SB, etc.).
  2. The field wire terminals for the pedestrian push button cables shall be labeled with the direction and location of button (NB-S.Side, etc.).
  3. Provide an AutoCAD drawing file of the as-built cabinet wiring diagram.
  4. All text on the cabinet wiring diagram shall use the Arial style font.
  5. Contractor is responsible for pickup of cabinet prints and for returning one revised print to the cabinet in the field and returning all other copies to the sign and signal shop.

## g. Spare Equipment

- i. The Contractor shall provide one spare flasher and one spare flasher relay for each cabinet supplied on the project.

## Xcluder Fill Fabric

- ii. Type V pedestrian standard bases shall have Xcluder Fill Fabric placed continuously around the inside of the lower plate to prevent rodents from accessing the base through space between concrete foundation and the lower plate. The fabric shall be secured to the anchor bolts and lower plate.

- h. Feed Point
  - i. All pedestrian flasher feed points shall be mounted on the side of the pedestrian flasher cabinet. Cabinet shall be weatherproof, lockable, safety switch with a 30 amp circuit breaker disconnect and lightning surge protection. Padlock shall be obtained from the City of Fargo Engineering Department. Install a by-pass meter socket and meter. This shall be incidental to the price bid for "Feed Point". Feed points shall require two ½" diameter by 10' long copper weld ground rods that are spaced 6' to 7' apart, ground wires shall be No.6 A.W.G.S.D. copper ground wire and shall be incased in 1" steel conduit where ever it is above ground with a steel treaded coupling that is encased and flush with the working slab. Power wires from the electrical provider to the meter socket shall be incased in 2" steel conduit where ever it is above ground with a steel treaded coupling that is encased and flush with the working slab.
- i. Pedestrian Flashing Beacon Standards
  - i. The Contractor will provide all new Type V pedestrian flasher standards. The standards, T-Bases shall be ordered from Brown Traffic Products. The poles shall be unpainted from the manufacturer and shall be professionally painted by a paint shop that is submitted by the Contractor and approved by the Engineer using the City of Fargo "Signal Paint" specification, all aluminum parts shall be treated with aluminum paint prep.
  - ii. The cost bid for this item shall include unloading, painting, storage, transportation, installation, miscellaneous hardware, installation of all signage, providing and installing all pedestrian buttons and signs, etc.
- j. Pedestrian Push Buttons and Signs
  - i. Pedestrian push button signs shall be bolted directly to the Type V pedestrian flasher standards. Do not use bandit for this purpose.
  - ii. Pedestrian push buttons shall be a Polara Rees Style Bulldog Button with momentary L.E.D. Model #RBDLM2-Y-2H (Yellow). Pedestrian push buttons shall have a Pelco SE-2000 Rectangular Series box pole mount #SE-0295-P01 (Yellow).
- k. Splices & conductors in pedestrian flasher standard bases, hand holes, etc.
  - i. Spliced or pulled through conductors shall have sufficient slack to extend a minimum of 18 inches outside of the enclosure. All above grade splices utilizing wire nuts shall be installed in their bases, hand holes, etc. with the wire nuts pointing up.
  - ii. Terminal blocks in the Type V pedestrian flasher standard bases shall be attached to a plastic plate with the minimum thickness of 3/8". The plate shall be a minimum of



2” larger than the terminal block on all sides. The termination shall be coated with red insulating varnish with a dielectric strength of 2100 volts/mil. The varnish shall be applied immediately after the terminations have been made. The terminal block shall face termination side face down in the transformer base.

24. CAMERA SYSTEM (Detail 5.9)

This shall include all camera wires, camera equipment specified, and all labor involved in providing a fully functional camera system that can be view on the City of Fargo network.

a. Equipment

- i. Control managed Ethernet switch specified on plan.
- ii. CAT 6 600 volt rated rugged cable
- iii. No.16 AWG 3 cable
- iv. Pelco IWM-GY mount
- v. 24 VAC power supply
- vi. PA402 pole mounting bracket
- vii. Pelco S5230-EG1 Spectra V HD network color/B/W dome with 30X optical zoom and image stabilization
- viii. 20 AMP four receptacle outlet with surge protection
- ix. Fiber optic jumpers

**PART 2**  
**MEASUREMENT & PAYMENT**

1. LINEAR FOOT

These items will be measured and paid by the Linear Foot as follows:

- a. Conduit
- b. Conductor Cable
- c. Opticom Cable
- d. Fiber Optics Cable
- e. Loop Wire
- f. Loop Lead-in Cable
- g. Saw Slot
- h. Coaxial Cable

2. EACH

These items will be measured by the number installed. Separate measurement will be made for each size or type if more than one size or type is installed. These items are as follows:

- a. Paint Traffic Signal Standards
- b. Sandblast Signal Standards
- c. Concrete Foundation Traffic Signal
- d. Remove Traffic Signal Foundation
- e. Remove Street Light
- f. Relocate Street Light Standard
- g. Traffic Signal Standards
- h. Install Pedestrian Push Button & Sign
- i. Relocate Pedestrian Post & Button
- j. Pedestrian Push Button Post
- k. Install LED Vehicle Section
- l. Install LED Pedestrian Section
- m. Pedestrian Head
- n. Vehicle Heads
- o. Electronic Signal Sign
- p. School Flashing Beacon
- q. Pedestrian Flashing Beacon Assembly
- r. Relocate Signal Head
- s. Install Cabinet & Controller
- t. Relocate Pull Box
- u. Remove Pull Box
- v. Install Fiber Pull Box

- w. Install PVC Pull Box
- x. Install Frame and Cover
- y. Traffic Signal Detector Loop
- z. Replace Traffic Signal Detector Loop
- aa. Install Micro Loop Probe
- bb. Install Preformed Loop
- cc. Furnish & Install Luminaire Extension
- dd. Revise Controller and Cabinet
- ee. Fargo Type B Cabinet
- ff. Emergency Vehicle Pre-emption System
- gg. Feed Point
- hh. Battery Backup System
- ii. Install Interim Signal System

3. LUMP SUM

These items will be measured by lump sum. These items are as follows:

- a. Traffic Signal System
- b. Modify Traffic Signal System
- c. Remove & Salvage Traffic Signal Equipment
- d. Install Flasher Cabinet
- e. Modify Existing Traffic Controller Cabinet
- f. Fiber Optic Terminations and Equipment
- g. Video Detection System
- h. Camera System
- i. Controller & Cabinet Assembly
- j. Temporary Signal Service

## TRAFFIC SIGNAL STANDARD FOUNDATIONS

TRAFFIC SIGNAL STANDARD FOUNDATION SELECTION TABLE				
SIGNAL STANDARD DESCRIPTION	24" DIAMETER FOOTING DEPTH	30" DIAMETER FOOTING DEPTH	36" DIAMETER FOOTING DEPTH	42" DIAMETER FOOTING DEPTH
TYPE I, II, V, VI, VII STANDARD				
10-14' HEIGHT	4'	4'	3'	-
15'-17' HEIGHT	6'	6'	5'	-
TYPE IV SIGNAL STANDARD				
0'-25' MAST ARM	-	11'	11'	11'
26'-30' MAST ARM	-	12'	12'	12'
31'-35' MAST ARM	-	12'	12'	12'
36'-39' MAST ARM	-	13'	13'	13'
40'-45' MAST ARM	-	15'	15'	15'
46'-50' MAST ARM	-	16'	15'	15'
51'-55' MAST ARM	-	16'	16'	16'
56'-60' MAST ARM	-	17'	17'	17'
61'-65' MAST ARM	-	18'	18'	18'
COMBO SIGNAL STANDARD 30' MT HEIGHT				
0'-25' MAST ARM	-	11'	11'	11'
26'-30' MAST ARM	-	12'	12'	12'
31'-35' MAST ARM	-	13'	13'	13'
36'-39' MAST ARM	-	14'	14'	14'
40'-45' MAST ARM	-	16'	15'	15'
46'-50' MAST ARM	-	16'	16'	16'
51'-55' MAST ARM	-	17'	16'	16'
56'-60' MAST ARM	-	18'	17'	17'
61'-65' MAST ARM	-	19'	18'	18'
COMBO SIGNAL STANDARD 40' MT HEIGHT				
0'-25' MAST ARM	-	12'	12'	12'
26'-30' MAST ARM	-	13'	13'	13'
31'-35' MAST ARM	-	13'	13'	13'
36'-39' MAST ARM	-	14'	14'	14'
40'-45' MAST ARM	-	16'	15'	15'
46'-50' MAST ARM	-	16'	16'	16'
51'-55' MAST ARM	-	17'	16'	16'
56'-60' MAST ARM	-	18'	17'	17'
61'-65' MAST ARM	-	19'	18'	18'
COMBO SIGNAL STANDARD 50' MT HEIGHT				
0'-25' MAST ARM	-	12'	12'	12'
26'-30' MAST ARM	-	13'	13'	13'
31'-35' MAST ARM	-	13'	13'	13'
36'-39' MAST ARM	-	14'	14'	14'
40'-45' MAST ARM	-	16'	16'	16'
46'-50' MAST ARM	-	16'	16'	16'
51'-55' MAST ARM	-	17'	17'	17'
56'-60' MAST ARM	-	18'	18'	17'
61'-65' MAST ARM	-	19'	19'	18'

### FOUNDATION NOTES:

- SEE PLANS FOR CORRECT LOCATION OF FOUNDATION. THE GRADE AND EXACT LOCATION SHALL BE ESTABLISHED BY THE ENGINEER IN THE FIELD.
- THE FOUNDATION SHALL PROVIDE A MINIMUM OF 3" OF CONCRETE COVER FROM THE ANCHOR BOLTS TO THE REBAR CAGE AND A MINIMUM OF 3" OF CONCRETE COVER OVER THE REBAR CAGE TO THE OUTSIDE OF THE FOUNDATION. THE DIAMETER OF THE FOUNDATION SHALL BE INCREASED TO ACCOMMODATE A LARGER BOL CIRCLE.
- AN ANCHOR BOLT CAGE SHALL BE SHOP FABRICATED FROM #6 BAR CIRCLE OR 3/4" SQUARE STOCK OR APPROVED EQUAL WELDED TO THE INSIDE OF THE ANCHOR BOLT TO HOLD ALIGNMENT.
- GROUND ROD SHALL BE PLACED PRIOR TO CONCRETE PLACEMENT. THE ROD SHALL PROJECT 4" ABOVE THE FINISHED FOUNDATION AND SHALL EXTEND 12" BELOW THE FOUNDATION BOTTOM.
- CONDUIT BENDS SHALL BE 90°. CONDUIT SHALL BE LOCATED 24" MINIMUM BELOW GROUND LEVEL. A SPARE 2" CONDUIT SHALL BE INSTALLED IN EACH FOUNDATION WITH BOTH ENDS PLUGGED AS PER SPARE CONDUIT SPECIFICATION.

### CONCRETE FOUNDATION:

- CONCRETE USED IN THE WORK SHALL BE CLASS AE PORTLAND CEMENT CONCRETE MIXED AND PROPORTIONED AS SPECIFIED IN SECTION 802.
- NOTE:  
THE TOP OF THE FOUNDATION SHALL BE CIRCULAR. IF APPROVED BY THE ENGINEER A SQUARE CASING MAY BE USED. PRIOR TO FINAL GRADING OR SIDEWALK PLACEMENT THE CASING TUBES SHALL BE REMOVED TO A POINT 6" BELOW GRADE.

### NOTES:

- NO REINFORCEMENT IS REQUIRED IF THE ANCHOR BOLTS EXTEND TO WITHIN 3" TO 6" ABOVE THE BOTTOM OF THE FOUNDATION FOR THE 24" DIAMETER FOUNDATION.
- ALL REINFORCING STEEL TO BE GRADE 40 OR 60.
- IF THE CONTRACTOR ELECTS TO USE A 24" SQUARE FOUNDATION, THE NEXT SIZE SMALLER REINFORCEMENT BARS MAY BE SUBSTITUTED FOR THOSE SHOWN IN THE TABLE. NO SUBSTITUTIONS MAY BE MADE FOR A 36" SQUARE FOUNDATION. #4 TIE BARS MAY BE SUBSTITUTED FOR THE SPIRAL, WITH THE BARS SPACED AT EQUAL SPACE TO A MAXIMUM OF 12" C. TO C., STARTING WITH THE FIRST AT THE TOP OF THE REINFORCING AND THE LAST AT THE BOTTOM OF THE REINFORCING. ROUND TIE BARS SHALL HAVE A MIN OF 12" OVERLAP.
- SEE PLANS FOR CONDUIT SIZE, NUMBER OF BENDS AND CORRECT POSITIONING FOR EACH FOUNDATION.

FOUNDATION REINFORCING TABLE	
FOOTING DEPTH	LONGITUDINAL REINFORCING
12' or Less	8 - #5
13'-14'	8 - #6
15'-16'	8 - #7
17'-19'	8 - #8

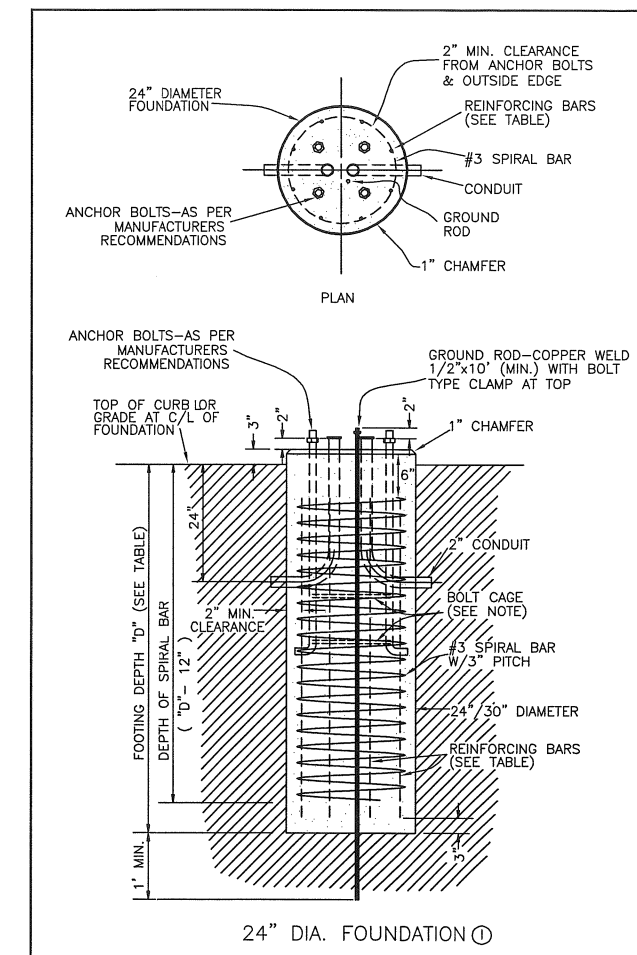
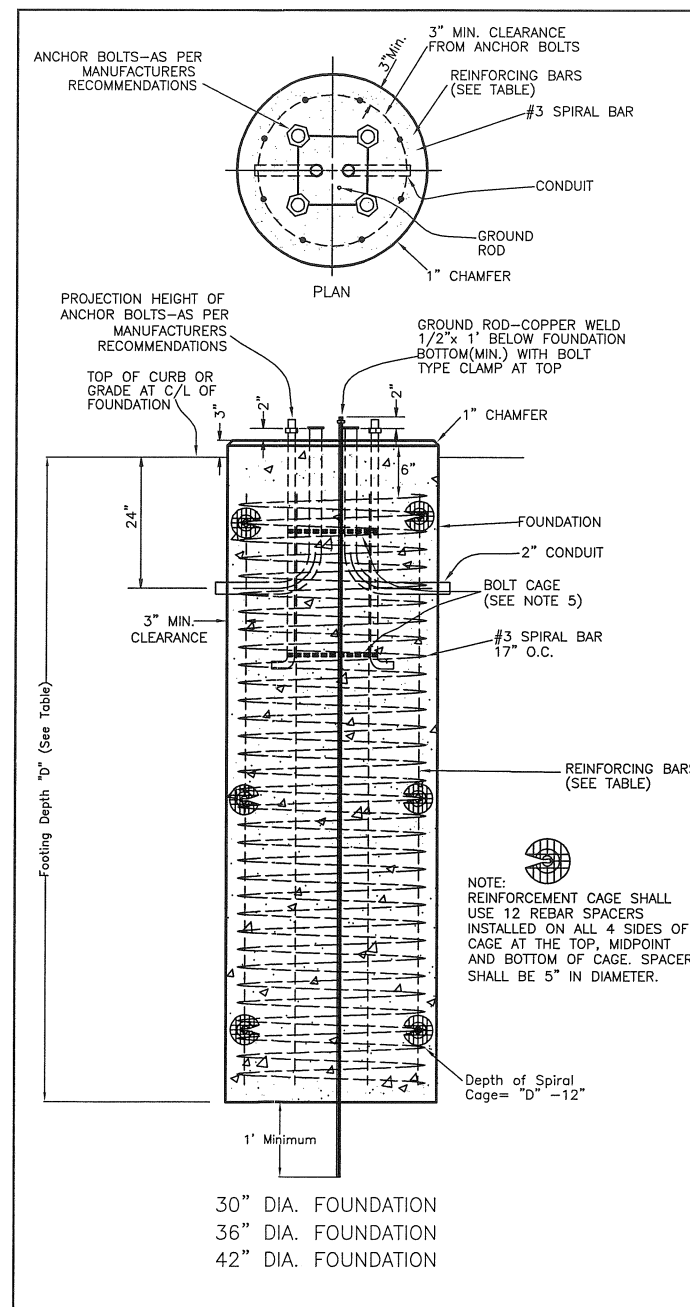

SECTION NO. 4200	DRAWING NO. 5.1
REV.D. 2012	
<b>TRAFFIC SIGNAL FOUNDATION</b>	
CITY OF FARGO ENGINEERING DEPARTMENT	
APPROVED <i>BEO</i>	DATE <i>2-21-2012</i>

**TYPE V, TYPE V,TYPE VIII SIGNAL STANDARDS**

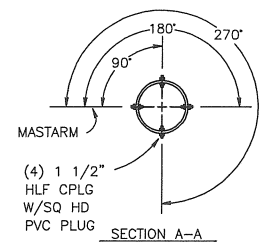

**POLES:**  
ALL TYPE V AND TYPE VI SIGNAL STANDARDS SHALL BE MANUFACTURED BY MILLERBERND MANUFACTURING AND HAVE A T-BASE INSTALLED.

3/16" x 7.17" x 4.5" x (100"/160"/190")

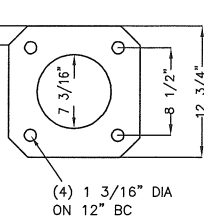
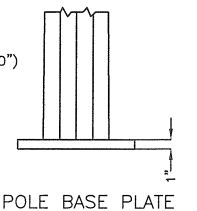
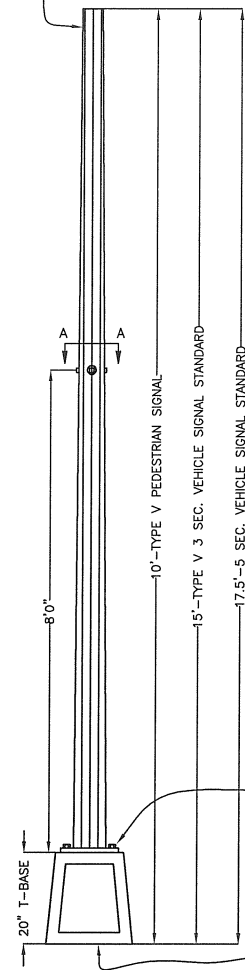

**NOTE:**  
POLE MATERIAL-HIGH STRENGTH LOW ALLOY STEEL 50,000 PSI MIN. YIELD PER ASTM A572 OR A1011(A871 OR A606 IF SELF WEATHERING) BASE PLATE MATERIAL-36,000 PSI MIN. YIELD PER ASTM A36(A588 IF SELF WEATHERING) SHALL BE PAINTED USING THE MILLERBOND 12/ZRU PAINT SYSTEM WITH A TOP CLEAR COAT.

(4) 1-8NC x 3 1/2" LG HVY HX HD BOLT, HVY HX NUT & LOCKWASHER (ASTM A325-GV) (INSTALL HD UP)

390C66 T-BASE  
1" ANCHOR BOLTS ON 15" BC WITH 4" PROJ

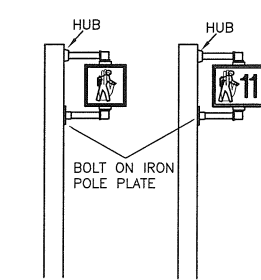

TYPE V-10' HEIGHT  
PEDESTAL MOUNTED-PEDESTRIAN

**NOTES:**  
CLEARANCE FROM GROUND LINE OR SIDEWALK TO THE BOTTOM OF POST OR PEDESTAL MOUNTED VEHICULAR SIGNAL HEADS SHALL BE 10 FT. MINIMUM FROM PEDESTRIAN SIGNAL SHALL BE 8 FT. MINIMUM.

**SIGNAL HEADS**  
SEE TRAFFIC LAYOUT FOR CORRECT MOUNTING POSITION, NUMBERS, SIZE, AND ARRANGEMENT OF LENSES.

**POLE CLAMPS**  
A POLE CLAMP WITH SUITABLE BANDING MATERIAL AS APPROVED BY THE ENGINEER SHALL BE USED.

**PAINT**  
SIGNAL HOUSING SHALL BE PAINTED YELLOW OR BLACK, SEE PLANS. BACK PLATES SHALL BE PAINTED FLAT BLACK. POLE CLAMPS AND SIGNAL HEAD MOUNTING HARDWARE SHALL BE PAINTED THE SAME COLOR AS THE SIGNAL STANDARD SHAFT.

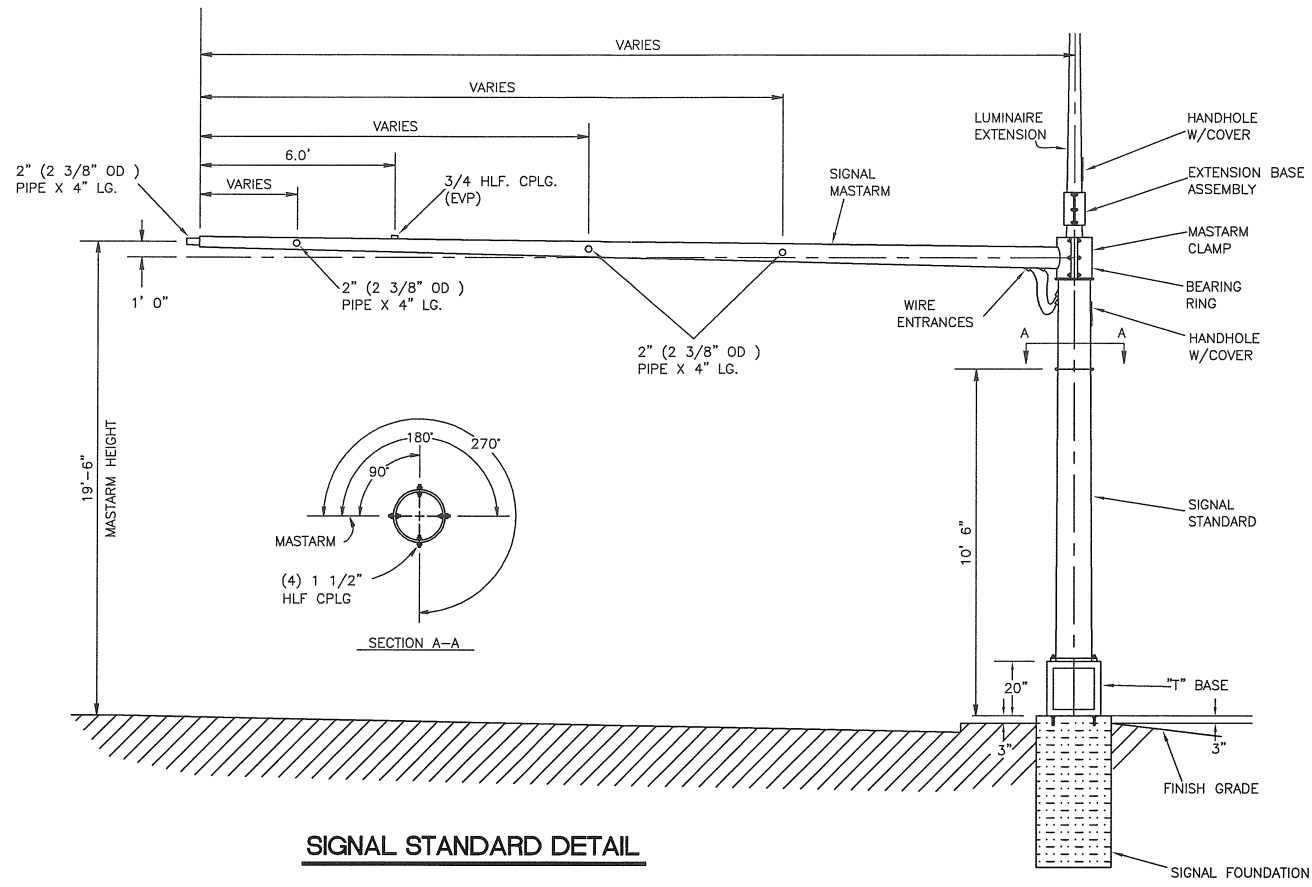

**SIGNAL STANDARD DETAIL**

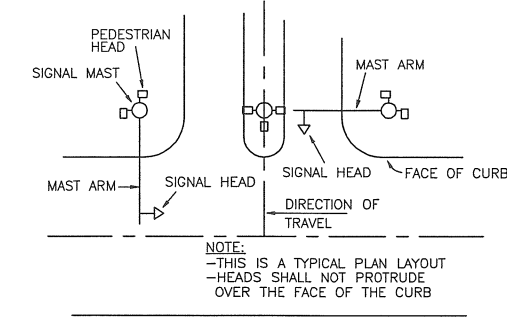

**NOTE:**  
-THIS IS A TYPICAL PLAN LAYOUT  
-HEADS SHALL NOT PROTRUDE OVER THE FACE OF THE CURB

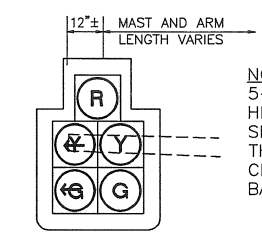

**NOTE:**  
5-SECTION CLUSTER HEAD ASTRO BRACKET SHALL BE MOUNTED TO THE MAST ARM AT THE CENTER OF THE YELLOW BALL HEAD.

**SIGNAL MAST ARM HEAD MOUNTING**

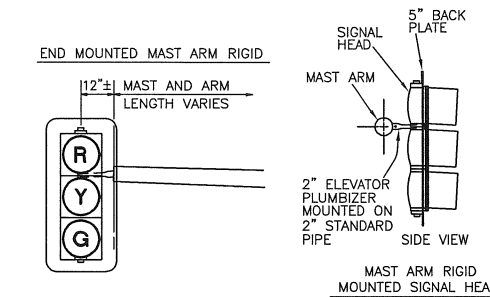

MAST ARM RIGID MOUNTED SIGNAL HEADS

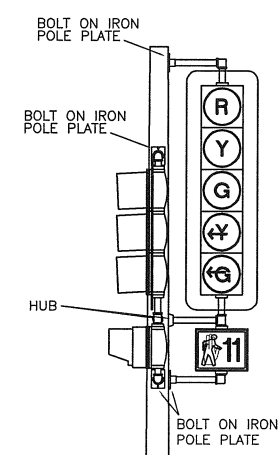

TYPE VI-17.5' HEIGHT  
PEDESTAL MOUNTED-VEHICULAR  
PEDESTAL MOUNTED-PEDESTRIAN

**NOTE:**  
TYPE V,TYPE VI, AND TYPE VIII SIGNAL STANDARDS THAT ARE 15' OR 17.5' IN HEIGHT SHALL USE A 24" CONCRETE SIGNAL FOUNDATION THAT IS 6' IN DEPTH.

**NOTE:**  
DRILL, TAP AND DIE MOUNTING HOLES. SECURE BOLT ON IRON POLE PLATE USING TWO 5/16" x 1 1/2" GALVANIZED HEX BOLTS USING A GALVANIZED WASHER AND A GALVANIZED LOCK WASHER ON EACH BOLT.

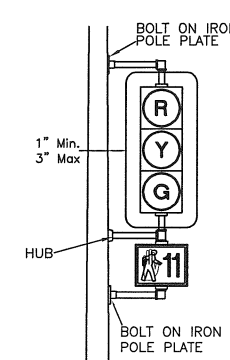

TYPE IV  
POST MOUNTED-VEHICULAR  
POST MOUNTED-PEDESTRIAN

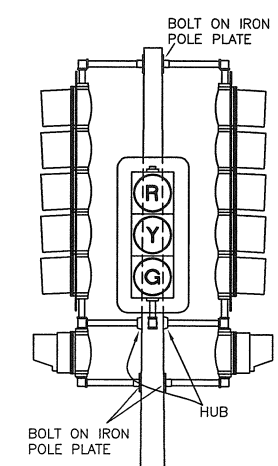

TYPE VIII-17.5' HEIGHT  
PEDESTAL MOUNTED-VEHICULAR  
PEDESTAL MOUNTED-PEDESTRIAN

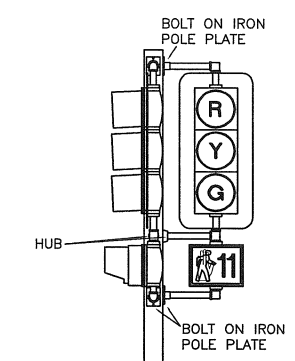

TYPE V-15' HEIGHT  
PEDESTAL MOUNTED-VEHICULAR  
AND PEDESTRIAN HEADS

**TRAFFIC SIGNAL HEAD MOUNTING**

SECTION NO. 4200	DRAWING NO. 5.2
REV.D. 2012	
<b>SIGNAL STANDARDS &amp; HEAD MOUNTING</b>	
CITY OF FARGO ENGINEERING DEPARTMENT	
APPROVED <i>BEO</i>	DATE <i>2-21-2012</i>

NOTE:  
CABINET SHALL BE SHOP  
COATED WITH ONE COAT  
OF PRIMER AND HAVE  
TWO COATS OF EXTERIOR  
GRAY ENAMEL.

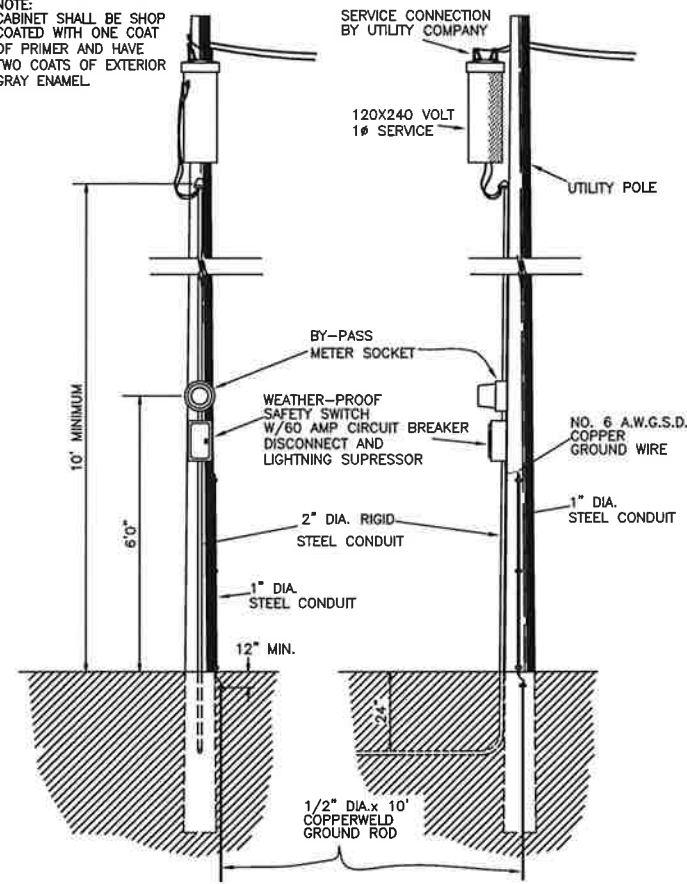

**POLE MOUNTED FEED POINT**

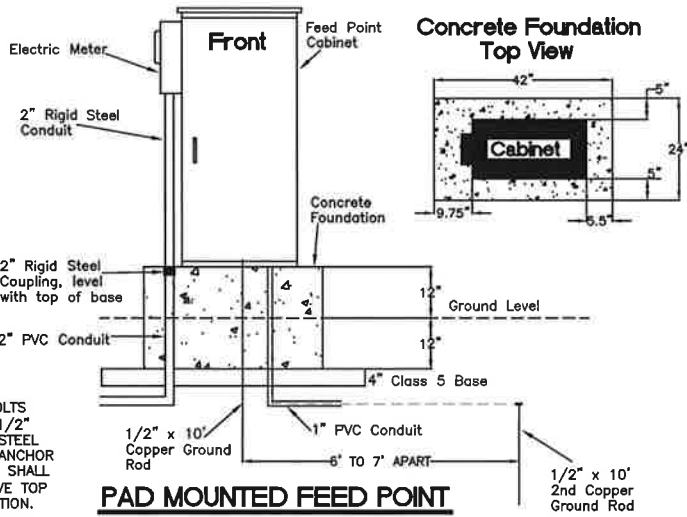
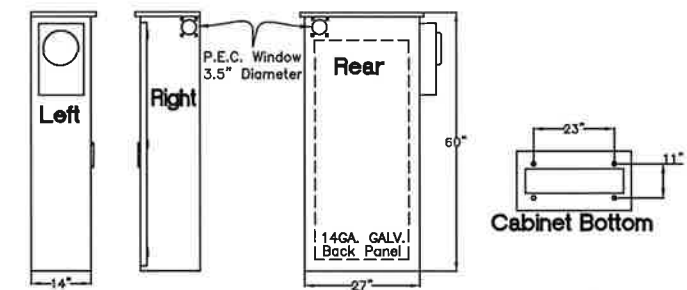

**PAD MOUNTED FEED POINT**

ANCHOR BOLTS  
SHALL BE 1/2\"/>

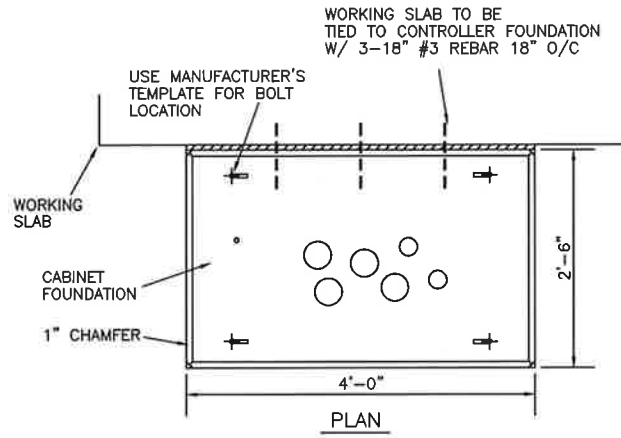

**PLAN**

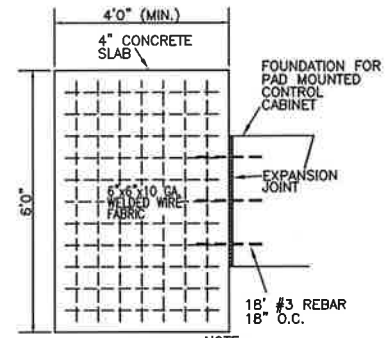

**PLAN**

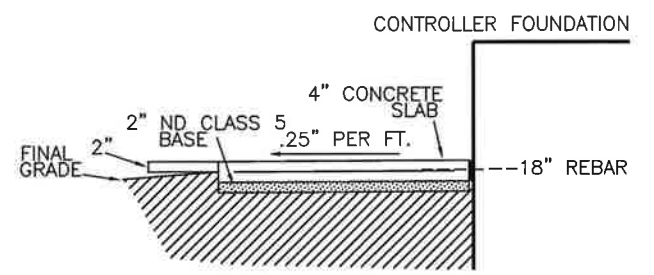

**SECTION**

INSTALL SLAB A MINIMUM  
OF 2\"/>

**CONTROLLER WORKING SLAB**

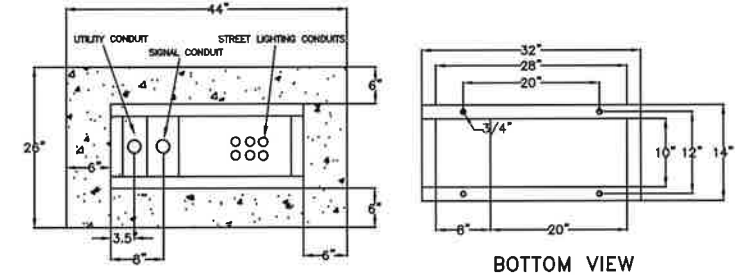

**BASE DETAIL**

**BOTTOM VIEW**

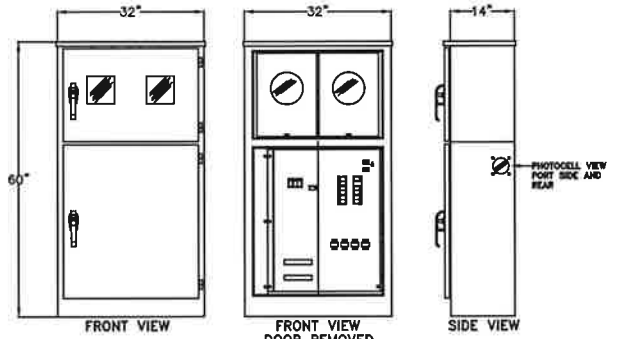

**FRONT VIEW**

**FRONT VIEW DOOR REMOVED**

**SIDE VIEW**

ANCHOR BOLTS  
SHALL BE 3/4\"/>

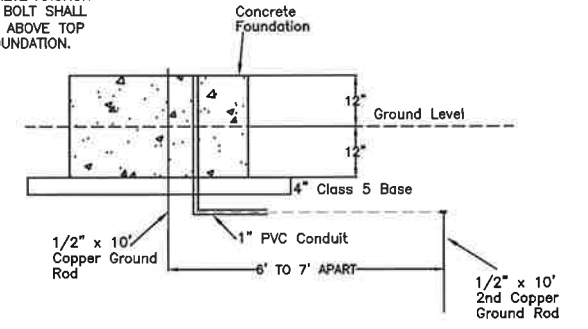

**COMBO PAD MOUNTED FEED POINT**

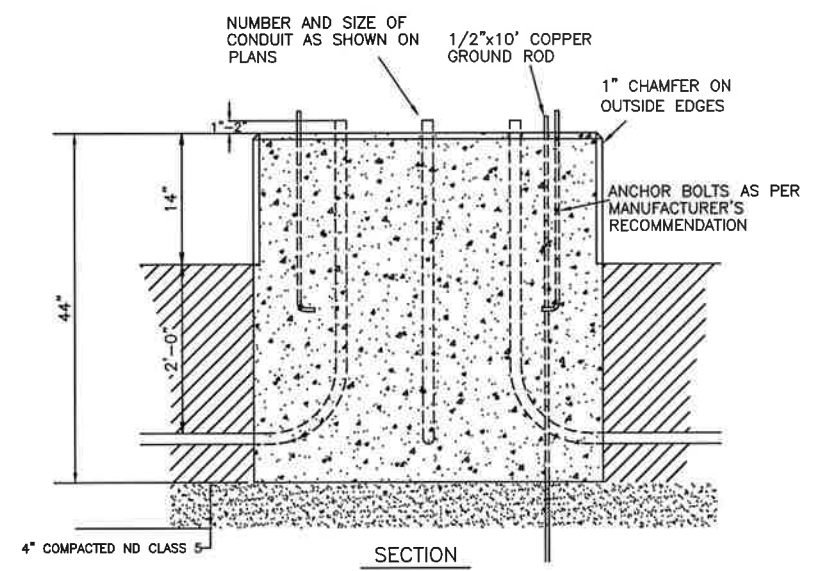

**SECTION**

ANCHOR BOLTS MUST BE SET INTO  
CONTROLLER FOUNDATION WHEN POURED

**CONTROLLER CABINET FOUNDATION PAD MOUNT**

SECTION NO. 4200	DRAWING NO. 5.3
REV.D. 2015	
<b>FEED POINT, PED. POST &amp; CABINET FOUNDATION</b>	
CITY OF FARGO ENGINEERING DEPARTMENT	
APPROVED <i>Jmg</i>	DATE 12-8-14

**SAW SLOT TO PULL BOX DETAILS**

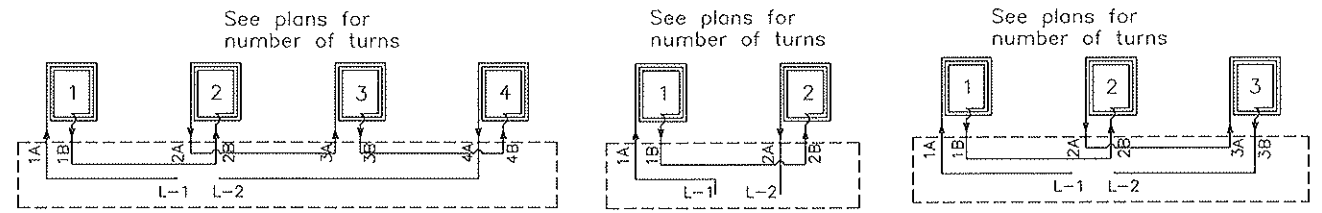
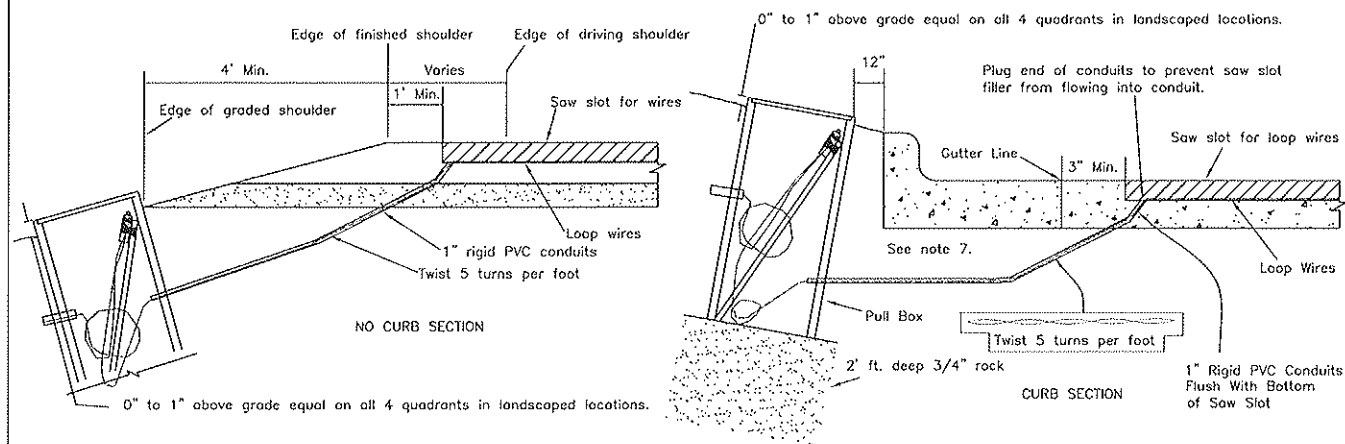

**MULTIPLE LOOP CONNECTION**  
All conductors shall be labeled in the pull box as shown (1A,1B,2A, etc.) The loop connections shall be spliced in the pull box: 1A to L1, 1B to 2B, 2A to 3A, 3B to 4B, and 4A to L2.

**MULTIPLE LOOP CONNECTION**  
All conductors shall be labeled in the pull box as shown (1A,1B,2A, etc.) The loop connections shall be spliced in the pull box: 1A to L1, 1B to 2B, and 2A to L2.

**MULTIPLE LOOP CONNECTION**  
All conductors shall be labeled in the pull box as shown (1A,1B,2A, etc.) The loop connections shall be spliced in the pull box: 1A to L1, 1B to 2B, 2A to 3A, and 3B to L2.

WIRE SHALL BE INSTALLED IN A CLOCKWISE/COUNTER CLOCKWISE ROTATION ON ALL LOOPS AS PER DETAIL.  
BOTH ENDS OF THE LOOP SHALL BE LABELED AS PER LOOP DETAIL.

**NOTES**

- 1) Loop saw cut shall be 2" deep in concrete and 2 1/2" to 4" deep in asphalt, saw depth in asphalt shall be determined by the engineer in the field, depending on road conditions.
- 2) All contraction joints and cracks crossed by saw slot must use a 1 1/4" wide saw slot. See note 1) for depth. See contraction joint detail. Contraction joint saw slot cut shall be cut in a single pass using stacked blades.
- 3) Duct type wire shall be used for all loops consisting of a High Density XLPE polyethylene tube and XHHW insulated wire. Provide slack at all drilled corners and contraction and crack joints. Use 1" long pieces of 3/4" boiler rod at required intervals, 2' max, in saw cut to prevent wire from floating.
- 4) Provide 3 turns in all loops.
- 5) Spacing of lead-in conduits shall be a minimum of 8" at the edge of road way surface or gutter line. See multiple loop detector detail. Lead-in loop pipe shall not enter gutter section.
- 6) Provide loop wire slack in J-box such that loop wire will extend a minimum of 6-feet above the top of the J-box.
- 7) Splices and Conductors in Pull Boxes: There shall be no splices below grade except for loop lead-in conductors. Wire nut together the spliced wires and encapsulate in an epoxy type splice kit. Conductors in the splice kit shall not be taped together. Loop lead-in and loop wires shall have sufficient slack to extend a minimum of 6 feet above the pull box opening and be installed in the pull box with the splice kit taped to a length of 1/2 PVC so the splice is secured inside the upper 1/4 of pull box ( See Detail ). Pull through. Conductors shall have sufficient slack to extend a minimum of 18-inches above the pull box opening.
- 8) Pull boxes in landscaped areas shall have the top of the box 0 to 1 inches above final grade and sloped to match the slope of the final grade on all four sides. Pull boxes in concrete areas shall be set with the top of the box flush with the final grade at all four sides. See pull box detail.

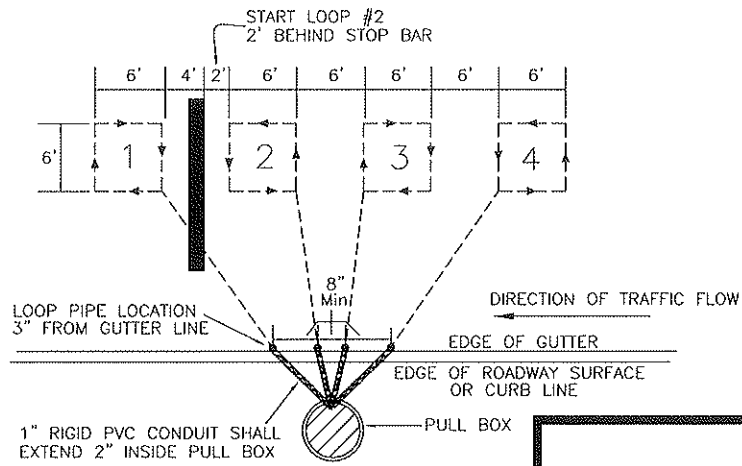

**MULTIPLE LOOP DETECTOR DETAIL (PRESENCE LOOPS)**

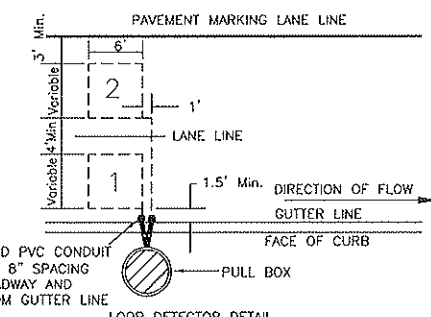

**LOOP DETECTOR DETAIL (PASSAGE OR CALLING)**

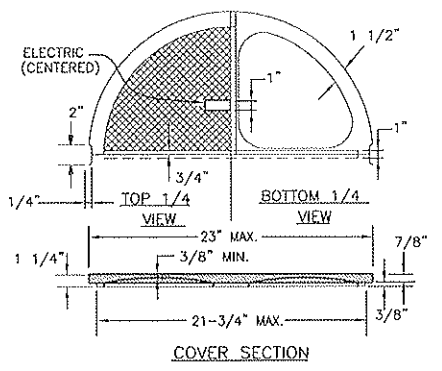
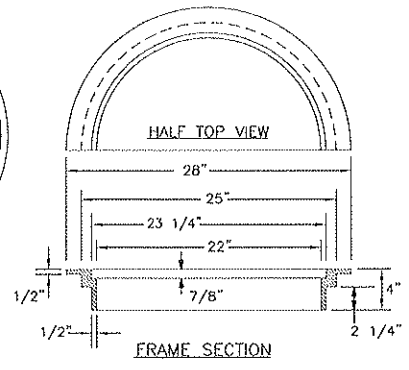
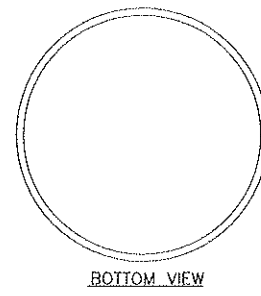
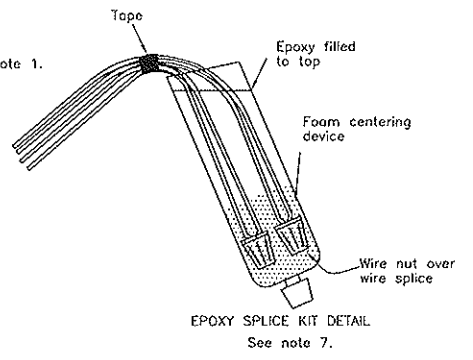
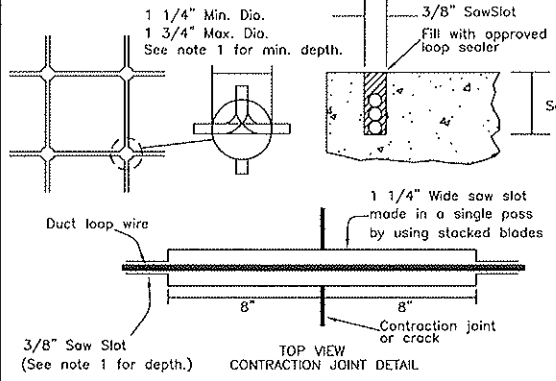

**FRAME AND COVER CASTING**

NOTE:  
ALL CASTINGS ARE GRAY IRON AS PER SPEC. 3321 CLASS 35B

**PULL BOX METAL FRAME AND COVER**

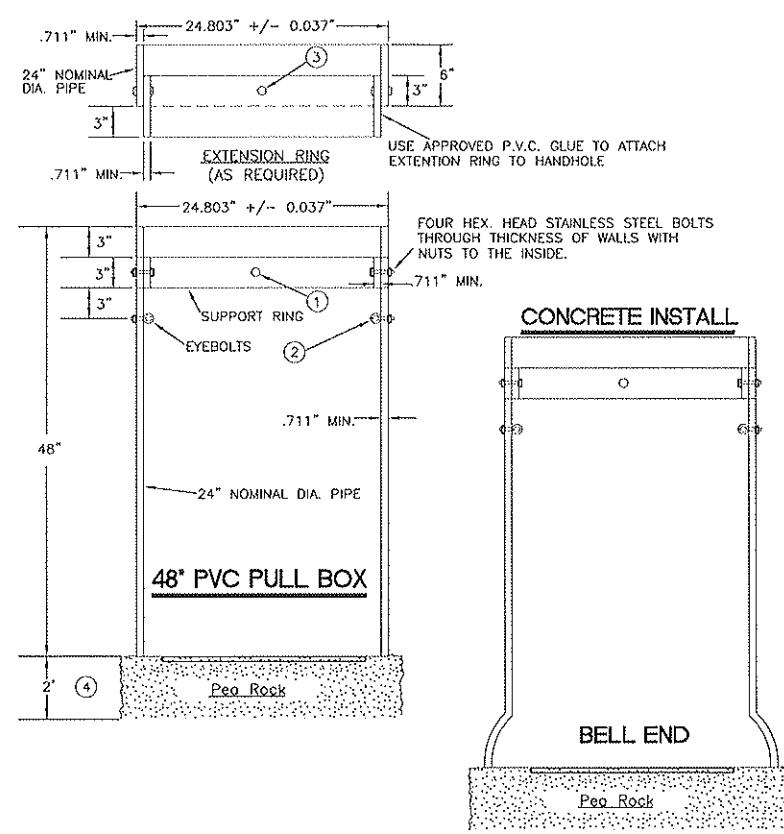

- 1) ATTACH SPLIT 24" NOM. DIA. P.V.C. COVER SUPPORT RING WITH FOUR 3/8" DIA. X 2" LONG STAINLESS STEEL HEX HEAD BOLTS WITH HEX NUTS AT 90° APART.
- 2) TWO TYPE 2 SHOULDER EYEBOLTS, 3/8" DIA. X 1 1/4" SHANK LENGTH, WITH HEX. NUTS AT 180° APART (FOR LIFTING HANDHOLES AND SUPPORTING ELECTRICAL CABLES)
- 3) ATTACH SPLIT 24" NOM. DIA. P.V.C. COVER SUPPORT EXTENSION RING WITH FOUR 3/8" DIA. X 2" LONG HEX. HEAD STAINLESS STEEL BOLTS WITH HEX. NUTS AT 90° APART. BOLT ASSEMBLY TOGETHER.
- 4) PLACE COMPACTED 2'-0" AGGREGATE DRAIN BED BELOW BOTTOM OF HANDHOLE, TO THE SATISFACTION OF THE ENGINEER.
- 5) CONDUIT HOLES LOCATED IN THE BARREL SECTION ARE SIZED NO MORE THAN 1" LARGER THAN THE CONDUIT USED.
- 6) AFTER HANDHOLE AND CONDUIT INSTALLATION, SEAL ALL INSIDE WALLS WATER TIGHT TO THE SATISFACTION OF THE ENGINEER.
- 7) THE P.V.C. PIPE COMPLIES WITH ASTM F6797-1.
- 8) HEX. HEAD BOLTS AND NUTS ARE TO BE STAINLESS STEEL. OTHER FASTENERS TO BE GALVANIZED AS PER AASHTO M-232

SECTION NO.	4200	DRAWING NO.	5.4
REV.D.	2012		
<b>DETECTOR LOOPS &amp; PULL BOX</b>			
CITY OF FARGO ENGINEERING DEPARTMENT			
APPROVED	JAB	DATE	1/2/2013

**PRE-EMPTION CABLE TERMINATION**

- TERMINAL T1  
PRE-EMPTION 1 AND 2-SHRINK WRAP GROUND WIRE
- TERMINAL T2  
PRE-EMPTION 1 AND 2-ORANGE WIRE-TOP TUBE
- TERMINAL T3  
PRE-EMPTION 1-TOP TUBE-BLUE WIRE
- TERMINAL T6  
PRE-EMPTION 2-BOTTOM TUBE-YELLOW WIRE
- TERMINAL T7  
PRE-EMPTION 3 AND 4-SHRINK WRAP GROUND WIRE
- TERMINAL T8  
PRE-EMPTION 3 AND 4-ORANGE WIRE-BOTTOM TUBE
- TERMINAL T9  
PRE-EMPTION 3-TOP TUBE-BLUE WIRE
- TERMINAL T12  
PRE-EMPTION 4-BOTTOM TUBE-YELLOW WIRE

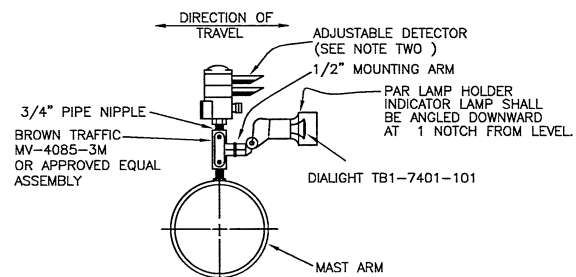
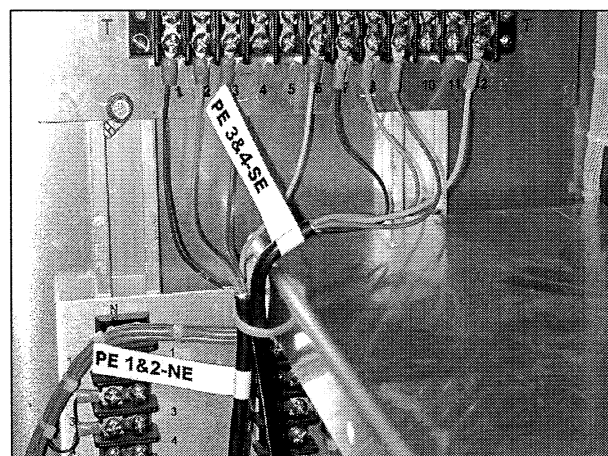

- NOTES:
1. TWO WAY DETECTOR SHALL HAVE TYPE X UNILET WITH ONE PAR LAMP HOLDERS AND LAMP.
  2. TWO-WAY DETECTOR SHALL HAVE THE DETECTOR LENS ROTATED TO FACE THE DIRECTIONS OF TRAVEL.

**EMERGENCY VEHICLE DETECTOR DETAIL (ADJUSTABLE)**  
(LOCATION AS SHOWN IN PLANS)

**MAST ARM MOUNTED STREET DESIGNATION SIGNS**

The following are examples of the sign format.



All mast arm mounted street designation signs shall utilize 18" 100 gauge flat aluminum, 48" or longer, depending on the space needed.

The signs shall have modified "E" series letters with a 12" upper and 9" lower case format and a 1" sign border. The superscripts shall be 6" (half size) capital letters and will line up with the top of the other letters and numbers.

The sign sheeting shall be 3M series DG3 sheeting, and any processed colors, inks, or electronic cuttable film shall be a matched component system.

NOTE:  
SIGNS MOUNTED ON THE SIGNAL STANDARD VERTICAL POST, EXCLUDING THE MAST ARMS SHALL BE INSTALLED BY DRILLING, TAPPING AND DIE THE POLE AND INSTALLING SIGNS WITH A 3/8" x 1" STAINLESS STEEL HEX BOLT USING A 3/8" STAINLESS STEEL FLAT WASHER AND A NYLON WASHER.

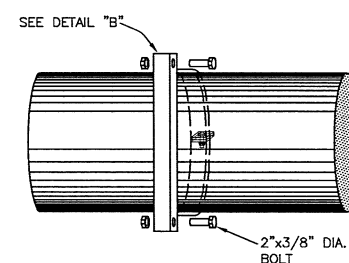
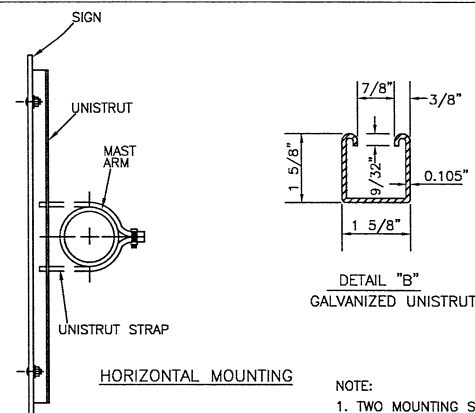

**MAST ARM MOUNTED SIGN DETAIL**

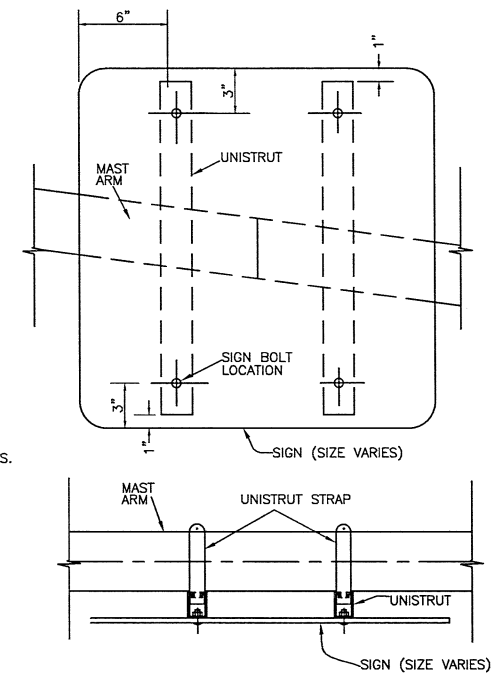

METAL WASHERS AND NYLON WASHERS USED ON SIGN FACE SHALL HAVE A MINIMUM OUTSIDE DIAMETER OF 15/16" ± 1/16" AND A 10 GA. THICKNESS.

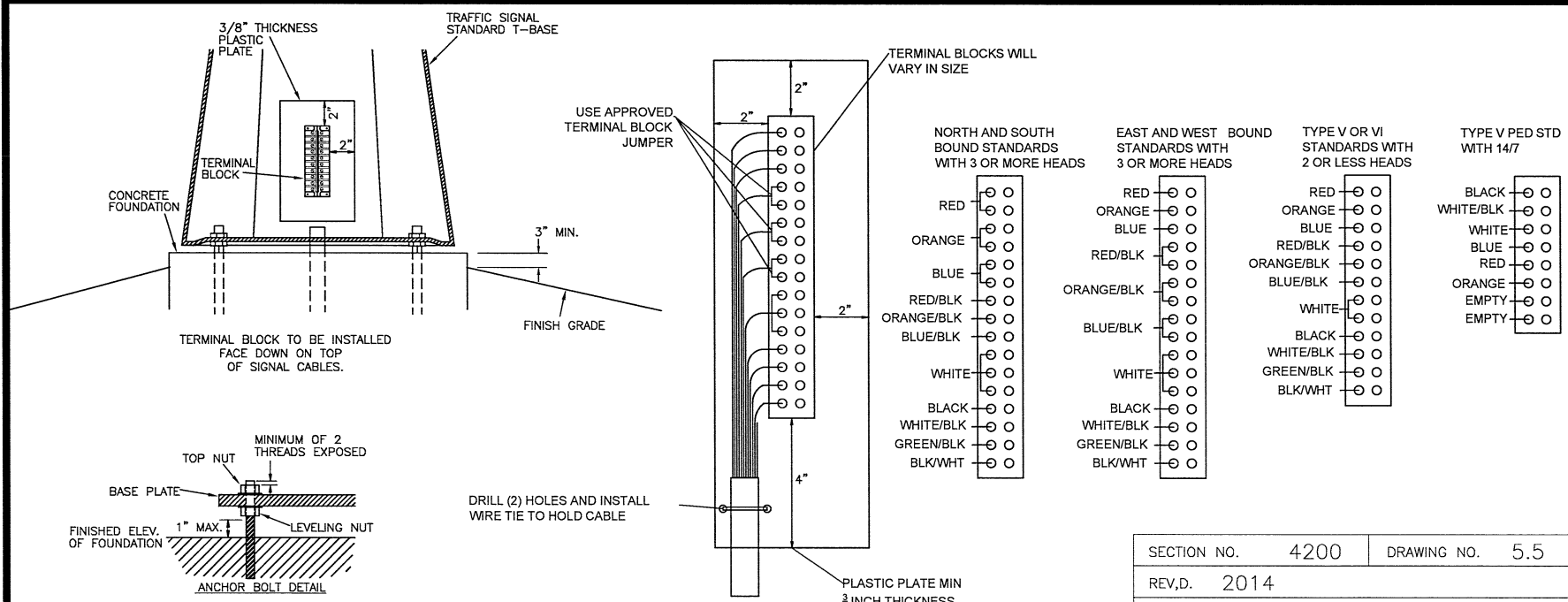

**TERMINAL BLOCK DETAIL**

SECTION NO.	4200	DRAWING NO.	5.5
REV.D.	2014		
<b>EVP SYSTEM, SIGNING &amp; TERMINAL BLOCK</b>			
CITY OF FARGO ENGINEERING DEPARTMENT			
APPROVED	JMG	DATE	12-19-13



PELCO PB-5325 THREE PIECE POLE & BASE COLLAR ASSEMBLY. DRILL OUT 3 HOLES IN THE PED. POLE BASE THAT ARE LINED UP AND THE SAME DIAMETER SIZE AS THE FACTORY HOLES IN THE PELCO BRACKET. BOLT THE BOTTOM OF THE PELCO BRACKET TO THE PED. POST BASE WITH THREE STAINLESS STEEL 5/16" X 1 1/2" BOLTS WITH LOCK WASHERS AND NUTS ON THE INSIDE.

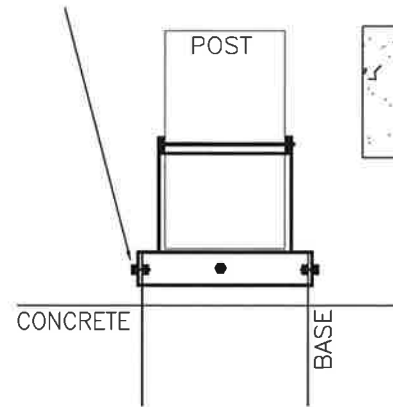

PED. POST  
DRILL OUT TWO 9/16" HOLES 3.25" UP FROM BOTTOM OF PED. POST PIPE ACROSS FROM EACH OTHER. SECURE A 1/2" X 6 1/2" STAINLESS STEEL HIGH STRENGTH BOLT WITH A LOCK WASHER AND NUT TO THE PED. POST.

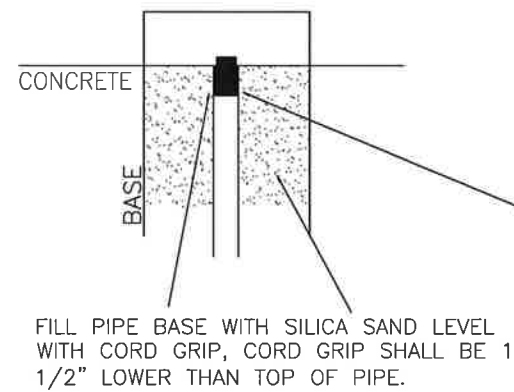
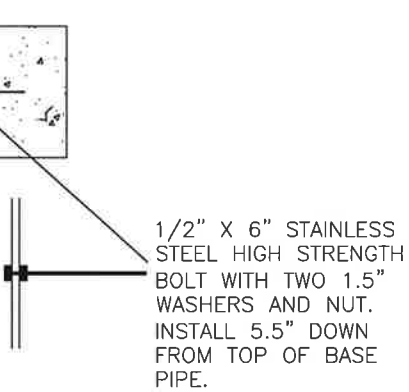

AMERACE FEMALE PLUG FAA L-823 TYPE II CLASS B STYLE 11 SECONDARY RECEPTACLE CONNECTOR KIT  
T&B CORD GRIP THM-2548 1 COORD L-T CONN MALL IRN .88-1.065 OR EQUAL APPROVED.  
1" PVC FA COUPLING

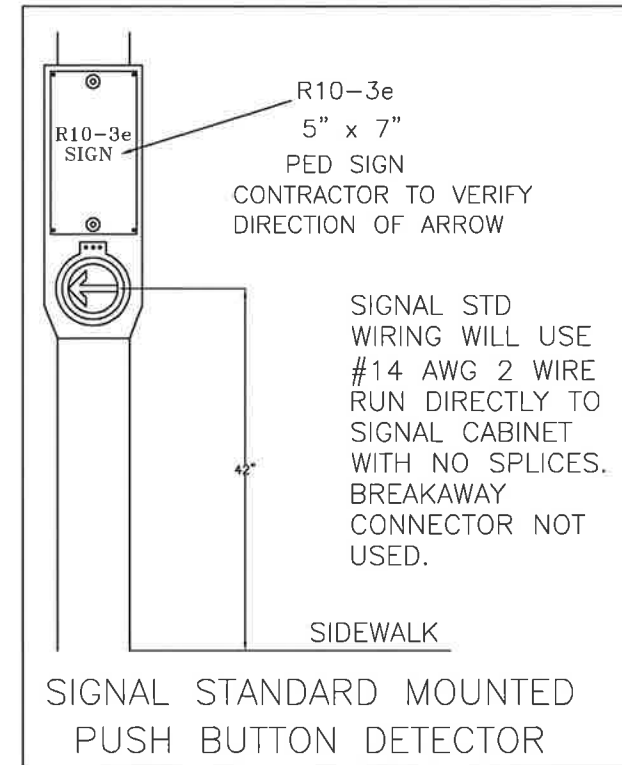
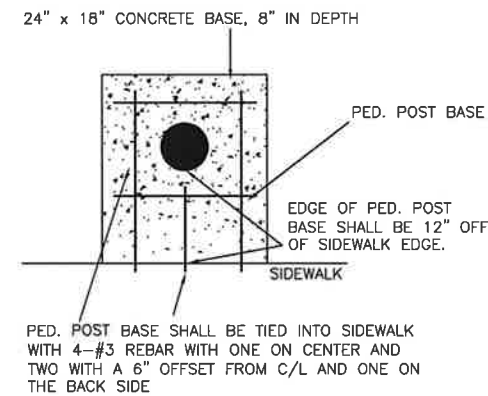
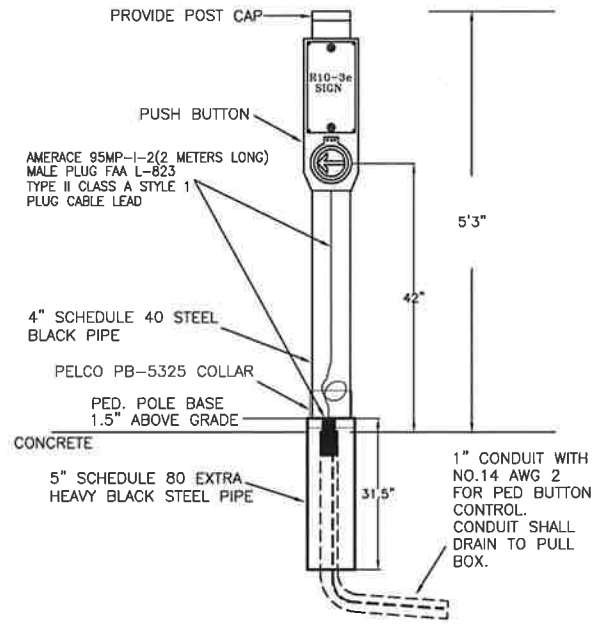

**PED. POST PIPE**

PED. POST SHALL BE SCHEDULE 40 CARBON STEEL BLACK LINE PIPE THAT CONFORMS TO ASTM-A53 O.D. 4.5" AND WALL THICKNESS OF .237".  
PED. BASE SHALL BE SCHEDULE 80 EXTRA HEAVY CARBON STEEL BLACK P.E. PIPE. O.D. 5.563" AND WALL THICKNESS OF .375".  
BOTH PRODUCTS ARE AVAILABLE FROM MCNEILUS STEEL INC. IN FARGO IN 21' LENGTHS PART NUMBERS BX4001 & BX500. THEY MAY ALSO BE AVAILABLE FROM ANY OTHER STEEL MANUFACTURER, BUT MUST MEET THE EXACT SAME SPECIFICATIONS.

**PEDESTRIAN PUSH BUTTON POST DETAILS**

SECTION NO.	4200	DRAWING NO.	5.6
REV.D.	2015		
<b>PUSH BUTTON POST DETAIL</b>			
CITY OF FARGO ENGINEERING DEPARTMENT			
APPROVED	<i>Jmh</i>	DATE	12-8-14

TRAFFIC SIGNAL STANDARD FOUNDATION SELECTION TABLE		
DESCRIPTION	24" DIAMETER REINFORCING BARS REQUIRED	24" DIAMETER FOOTING DEPTH "D"
TYPE V PED. FLASHER	4-#5 ①	4'

**NOTES:**

- NO REINFORCEMENT IS REQUIRED IF THE ANCHOR BOLTS EXTEND TO WITHIN 3" TO 6" ABOVE THE BOTTOM OF THE FOUNDATION.
- ALL REINFORCING STEEL TO BE GRADE 40 OR 60.
- SEE PLANS FOR CONDUIT SIZE, NUMBER OF BENDS AND CORRECT POSITIONING FOR EACH FOUNDATION.
- WHEN CONDUIT DOES NOT CONTINUE BEYOND THE FOUNDATION, CONDUIT WITH A 105° BEND AND BUSHINGS ON BOTH ENDS MAY BE SUBSTITUTED FOR THE 90° BENDS SHOWN.
- SEE PLANS FOR CORRECT LOCATION OF FOUNDATIONS. THE GRADE AND EXACT LOCATION SHALL BE ESTABLISHED BY THE ENGINEER IN THE FIELD.
- MAXIMUM BOLT CIRCLE FOR THE 24" FOUNDATION SHALL NOT EXCEED 18".

**CONCRETE FOUNDATION:**

1. CONCRETE USED IN THE WORK SHALL BE CLASS AE PORTLAND CEMENT CONCRETE MIXED AND PROPORTIONED AS SPECIFIED IN SECTION 802.

NOTE:  
THE TOP OF THE FOUNDATION SHALL BE CIRCULAR.

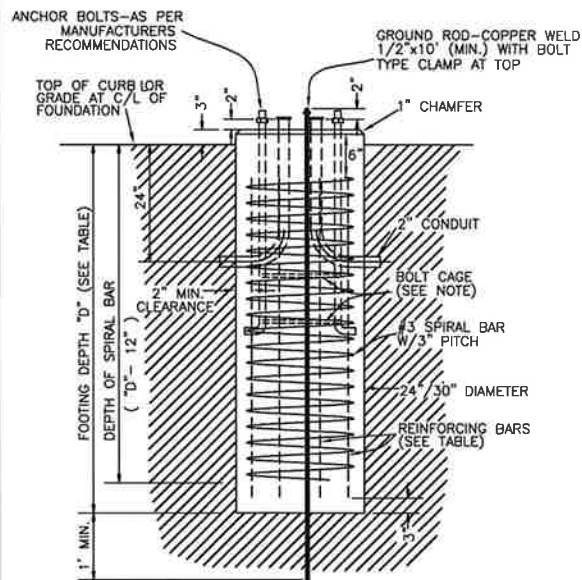
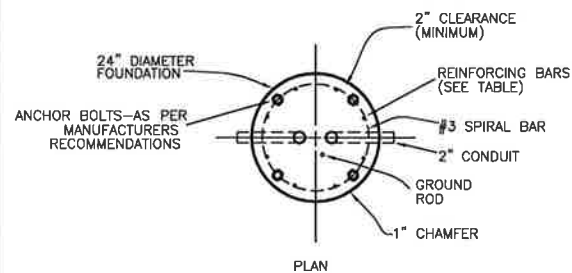

ELEVATION  
24" DIA. FOUNDATION  
**TYPE V PEDESTRIAN FLASHER FOUNDATIONS**

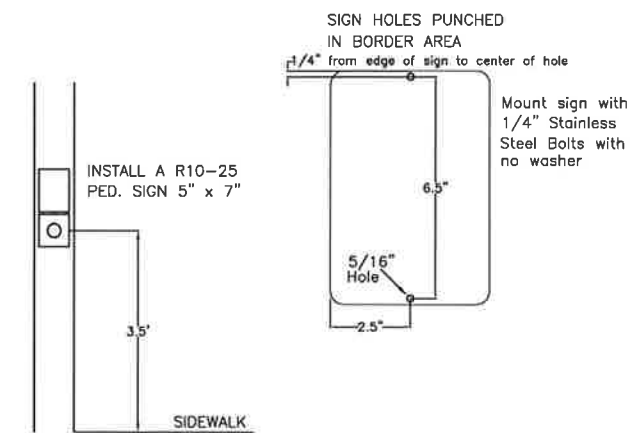

TYPE V PED. FLASHER MOUNTED  
PUSH BUTTON DETECTOR

R10-25  
5" x 7"  
PED SIGN

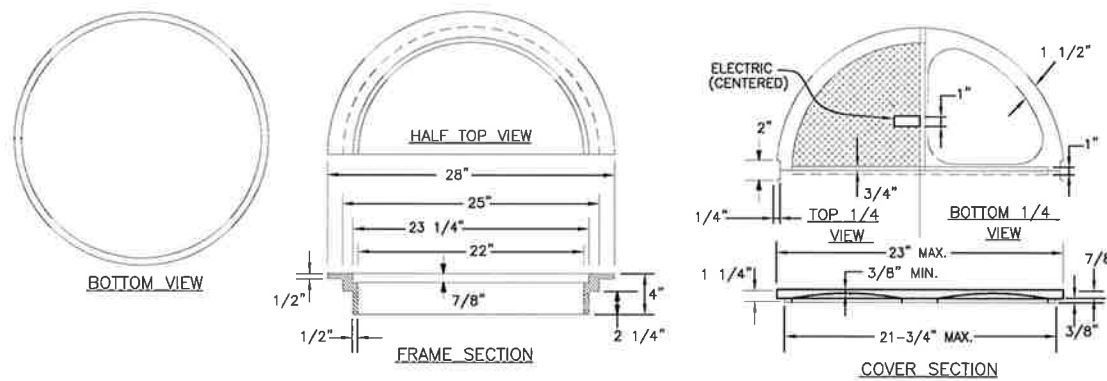

**PULL BOX METAL FRAME AND COVER**

**FRAME AND COVER CASTING**

NOTE:  
ALL CASTINGS ARE GRAY IRON AS PER SPEC. 3321 CLASS 35B

**4" SIGNAL STANDARD BASE ANCHOR BOLT PLATE**

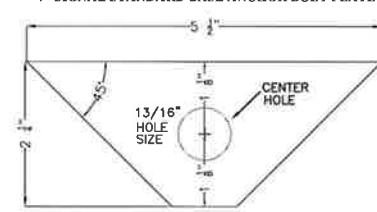

NOTES:  
1. CUT FROM 1/4" WIDE GALVANIZED STEEL  
2. THIS PLATE SHALL BE INSTALLED BETWEEN THE BASE AND THE ANCHOR BOLT NUT IN ALL 4" TYPE V SIGNAL STANDARD BASES.

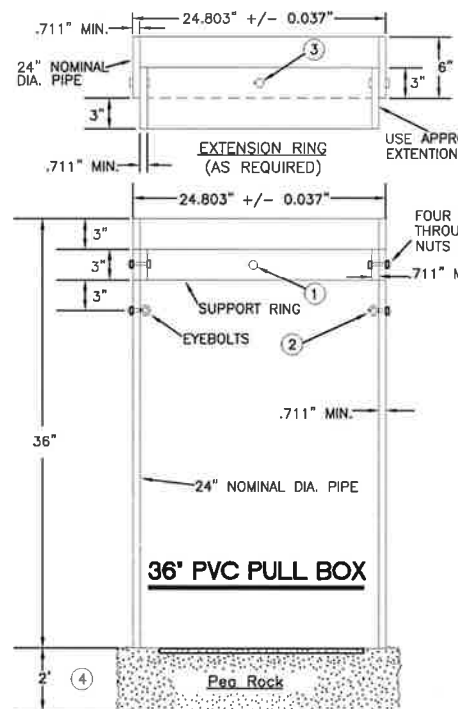

**36" PVC PULL BOX**

- ATTACH SPLIT 24" NOM. DIA. P.V.C. COVER SUPPORT RING WITH FOUR 3/8" DIA. X 2" LONG STAINLESS STEEL HEX HEAD BOLTS WITH HEX NUTS AT 90° APART.
- TWO TYPE 2 SHOULDER EYEBOLTS, 3/8" DIA. X 1 1/4" SHANK LENGTH, WITH HEX. NUTS AT 180° APART (FOR LIFTING HANDHOLES AND SUPPORTING ELECTRICAL CABLES)
- ATTACH SPLIT 24" NOM. DIA. P.V.C. COVER SUPPORT EXTENSION RING WITH FOUR 3/8" DIA. X 2" LONG HEX. HEAD STAINLESS STEEL BOLTS WITH HEX. NUTS AT 90° APART. BOLT ASSEMBLY TOGETHER.
- PLACE COMPACTED 2'-0" AGGREGATE DRAIN BED BELOW BOTTOM OF HANDHOLE, TO THE SATISFACTION OF THE ENGINEER.
- CONDUIT HOLES LOCATED IN THE BARREL SECTION ARE SIZED NO MORE THAN 1" LARGER THAN THE CONDUIT USED.
- AFTER HANDHOLE AND CONDUIT INSTALLATION, SEAL ALL INSIDE WALLS WATER TIGHT TO THE SATISFACTION OF THE ENGINEER.
- THE P.V.C. PIPE COMPLIES WITH ASTM F679T-1.
- HEX. HEAD BOLTS AND NUTS ARE TO BE STAINLESS STEEL. OTHER FASTENERS TO BE GALVANIZED AS PER AASHTO M-232

ALL PVC PULL BOXES INSTALLED IN CONCRETE AREAS SHALL HAVE A BELL END AS PER DWG 5.4

**TYPE V PEDESTRIAN FLASHER**

TYPE V 4" SIGNAL STANDARD SHALL BE SCHEDULE 80 SPUN ALUMINUM.

**L.E.D. SIGNAL HEAD**  
12" Lense  
SIG Polycarbonate

NO.12 AWG 2 CONDUCTOR IS RUN FROM EACH HEAD TO THE TERMINAL BLOCK INSIDE THE T-BASE

INSTALL A NO.12 AWG 5 CONDUCTOR FROM EACH PEDESTRIAN FLASHER TERMINAL BLOCK TO THE FLASHER CABINET CONNECTIONS.

SECURE BOLT ON IRON POLE PLATE WITH CABLE GUIDE USING TWO 5/16" x 1 1/2" GALVANIZED HEX BOLTS USING A GALVANIZED WASHER AND A GALVANIZED LOCK WASHER ON EACH BOLT.

DRILL, TAP AND DIE THE POLE AND INSTALL SIGNS WITH A 3/8" x 1" STAINLESS STEEL HEX BOLT USING A 3/8" STAINLESS STEEL FLAT WASHER AND A NYLON WASHER.

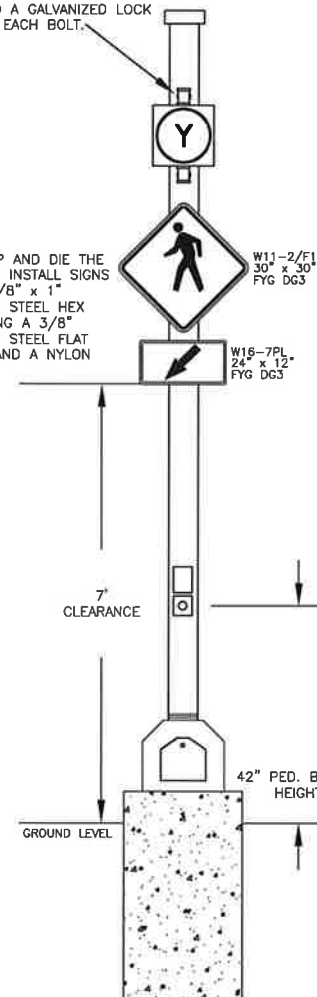

ND FARGO PUSH BUTTON ACTIVATED FLASHER CABINET W/HOA SWITCH:  
FC-1189-PM = PEDESTAL MOUNTED  
FC-1189-SOPM = SIDE OF POLE MOUNTED  
FC-1189-WM = WALL MOUNTED  
CABINET 36"H x 20"W x 15"D

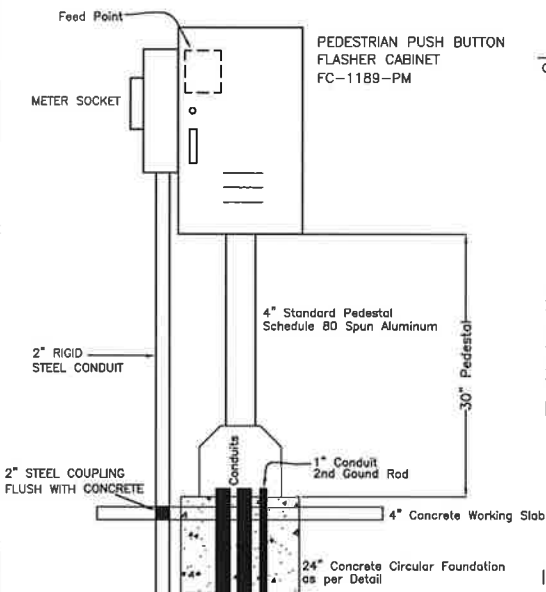

ALL CENTER MEDIAN ISLAND TYPE V FLASHERS SHALL HAVE 2 LED YELLOW FLASHERS AND 2 PEDESTRIAN SIGNS ON TYPE V POLE, ONE SET FACING EACH DIRECTION OF TRAFFIC.

INSTALL A NO.12 AWG 2 CONDUCTOR FROM PEDESTRIAN PUSH BUTTON TO THE FLASHER CABINET CONNECTIONS.

CABINET SHALL BE A PUSH BUTTON ACTIVATED FLASHER CABINET W/HOA SWITCH MANUFACTURED BY BROWN TRAFFIC PRODUCTS, WITH A FLASHING CIRCUIT PANEL, A GENERAL PURPOSE RELAY, FLASHER RELAY AND MULTIFUNCTION TIME DELAY RELAY. CABINET SHALL HAVE ITS OWN 15 AMP CIRCUIT BREAKER.

SECTION NO.	4200	DRAWING NO.	5.7
REV.D.	2015		
<b>PEDESTRIAN FLASHER</b>			
<b>PULL BOX EXTENTION</b>			
CITY OF FARGO ENGINEERING DEPARTMENT			
APPROVED	Jmk	DATE	12-8-14

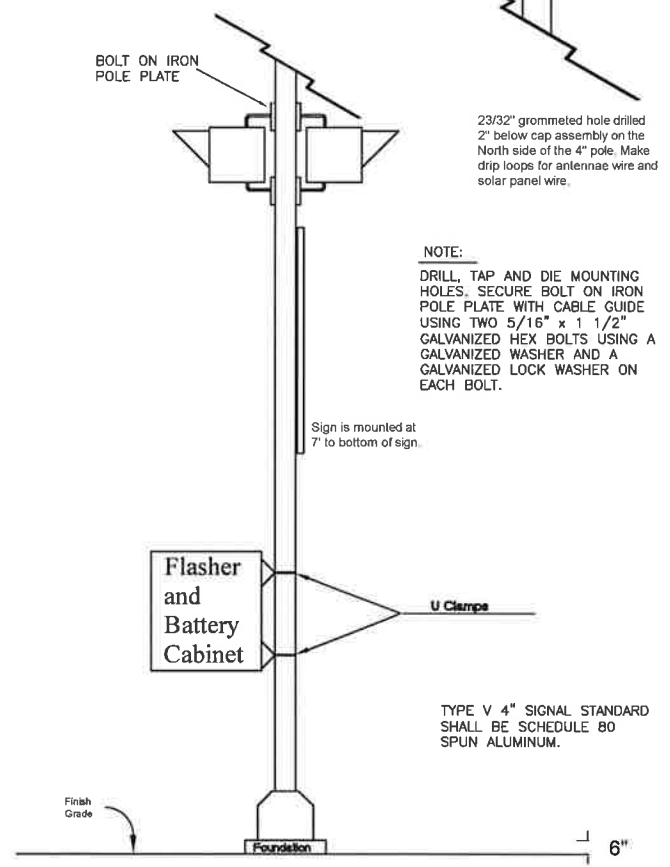
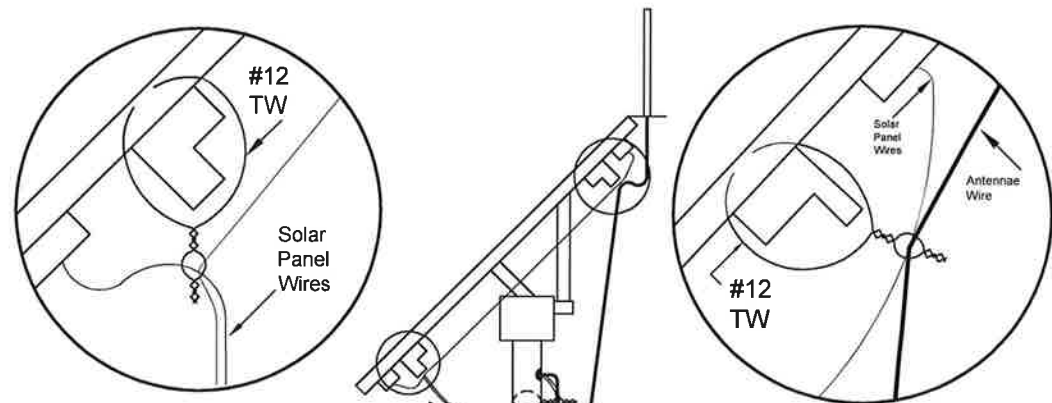

15' Pole plus the Base

NOTE:  
 DRILL, TAP AND DIE MOUNTING HOLES. SECURE BOLT ON IRON POLE PLATE WITH CABLE GUIDE USING TWO 5/16" x 1 1/2" GALVANIZED HEX BOLTS USING A GALVANIZED WASHER AND A GALVANIZED LOCK WASHER ON EACH BOLT.

Sign is mounted at 7' to bottom of sign.



DRILL, TAP AND DIE THE POLE WITH 3 HOLES AND INSTALL SIGNS WITH A 3/8" x 1" STAINLESS STEEL HEX BOLT USING A 3/8" STAINLESS STEEL FLAT WASHER AND A NYLON WASHER.

TRAFFIC SIGNAL STANDARD FOUNDATION SELECTION TABLE		
DESCRIPTION	24" DIAMETER REINFORCING BARS REQUIRED	24" DIAMETER FOOTING DEPTH "D"
TYPE V PED. FLASHER	4-#5 ①	4'

- NOTES:
- NO REINFORCEMENT IS REQUIRED IF THE ANCHOR BOLTS EXTEND TO WITHIN 3" TO 6" ABOVE THE BOTTOM OF THE FOUNDATION.
  - ALL REINFORCING STEEL TO BE GRADE 40 OR 60.
  - SEE PLANS FOR CORRECT LOCATION OF FOUNDATIONS. THE GRADE AND EXACT LOCATION SHALL BE ESTABLISHED BY THE ENGINEER IN THE FIELD.
  - MAXIMUM BOLT CIRCLE FOR THE 24" FOUNDATION SHALL NOT EXCEED 18".

**CONCRETE FOUNDATION:**

1. CONCRETE USED IN THE WORK SHALL BE CLASS AE PORTLAND CEMENT CONCRETE MIXED AND PROPORTIONED AS SPECIFIED IN SECTION 802.

NOTE:  
 THE TOP OF THE FOUNDATION SHALL BE CIRCULAR.

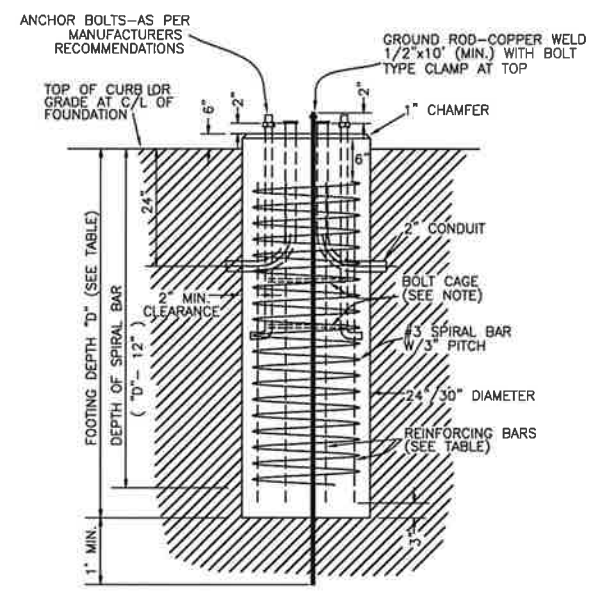

ELEVATION  
 24" DIA. FOUNDATION  
**SOLAR SCHOOL  
 FLASHER FOUNDATIONS**

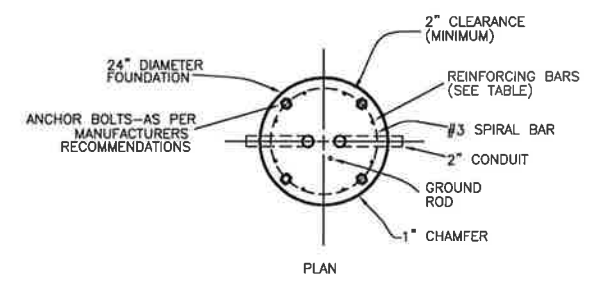

**4" SIGNAL STANDARD BASE ANCHOR BOLT PLATE**

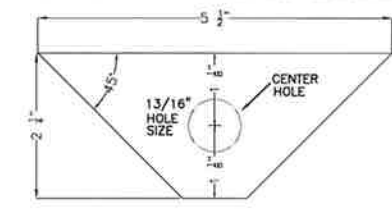

- NOTES:
- CUT FROM 1/4" WIDE GALVANIZED STEEL
  - THIS PLATE SHALL BE INSTALLED BETWEEN THE BASE AND THE ANCHOR BOLT NUT IN ALL 4" TYPE V SIGNAL STANDARD BASES.

SECTION NO. 4200	DRAWING NO. 5.8
REV.D. 2015	
<b>SOLAR SCHOOL    ZONE FLASHER</b>	
CITY OF FARGO ENGINEERING DEPARTMENT	
APPROVED <i>Jmk</i>	DATE 12-8-14

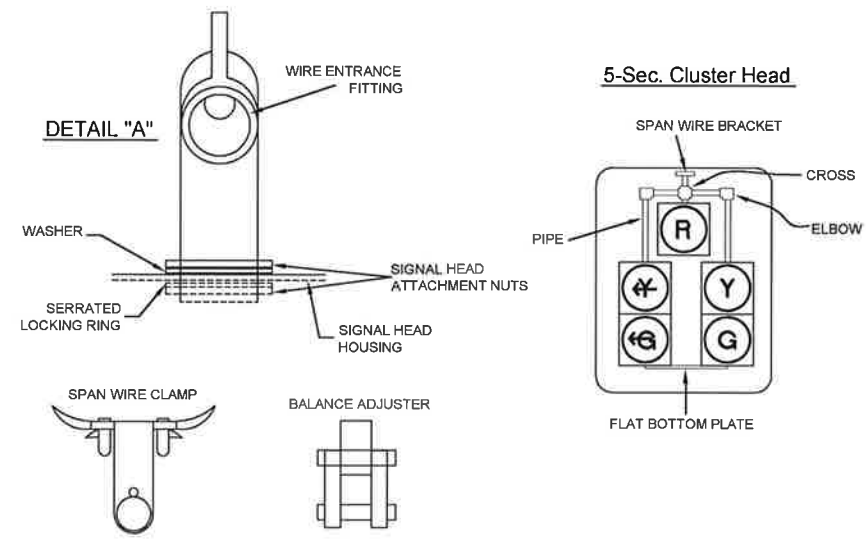
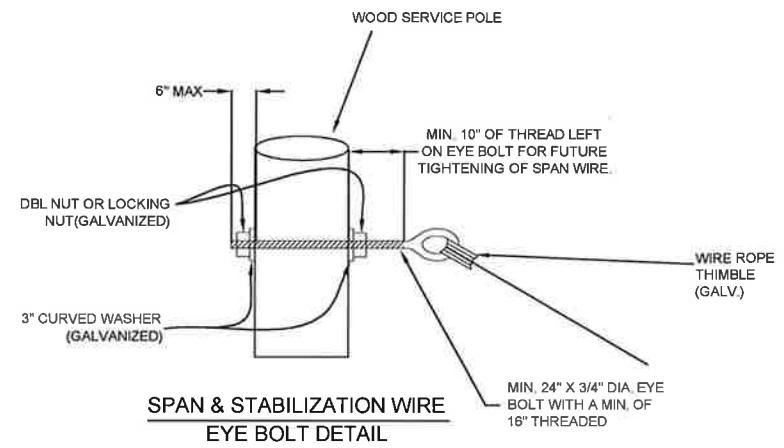

OVERHEAD INTERIM TRAFFIC SIGNAL SPAN LENGTHS											
MAXIMUM SPAN LENGTH	ONE TRAFFIC SIGNAL HEAD				TWO TRAFFIC SIGNAL HEAD						
	3/8 INCH SPAN WIRE WITH 3/8 INCH STABILIZATION WIRE	3/8 INCH SPAN WIRE WITH 3/8 INCH STABILIZATION WIRE	1/2 INCH SPAN WIRE WITH 1/2 INCH STABILIZATION WIRE	5/8 INCH SPAN WIRE WITH 5/8 INCH STABILIZATION WIRE	3/8 INCH SPAN WIRE WITH 3/8 INCH STABILIZATION WIRE	3/8 INCH SPAN WIRE WITH 3/8 INCH STABILIZATION WIRE	1/2 INCH SPAN WIRE WITH 1/2 INCH STABILIZATION WIRE	5/8 INCH SPAN WIRE WITH 5/8 INCH STABILIZATION WIRE			
	HIGH STRENGTH STEEL				HIGH STRENGTH STEEL						
	FT	FT	FT	FT	FT	FT	FT	FT			
	110	130	150	165	65	85	125	150			
	EXTRA HIGH STRENGTH STEEL				EXTRA HIGH STRENGTH STEEL						
	FT	FT	FT	FT	FT	FT	FT	FT			
	140	160	185	200	90	120	160	185			
	THREE TRAFFIC SIGNAL HEAD				FOUR TRAFFIC SIGNAL HEAD						
	HIGH STRENGTH STEEL				HIGH STRENGTH STEEL						
	FT	FT	FT	FT	FT	FT	FT	FT			
	45	60	100	130	35	50	80	110			
	EXTRA HIGH STRENGTH STEEL				EXTRA HIGH STRENGTH STEEL						
	FT	FT	FT	FT	FT	FT	FT	FT			
	65	85	130	165	50	65	110	145			

A. ANGLE	MIN. ANCHOR RESISTANCE
30°	12,000 LBS.
15°	24,500 LBS.

B. POLE DEPTH OF SETTING	LENGTH OF POLE	DEPTH IN GROUND (MIN)
	35	6'
	40	6'
	45	6 1/2'
	50	7'
	55	7'

CLASS II WOOD POLES, TREATED IN ACCORDANCE WITH SECTION 846 OF STANDARD SPECIFICATIONS (SEE PLANS FOR LOCATION AND LENGTH)

**INTERIM TRAFFIC SIGNAL**

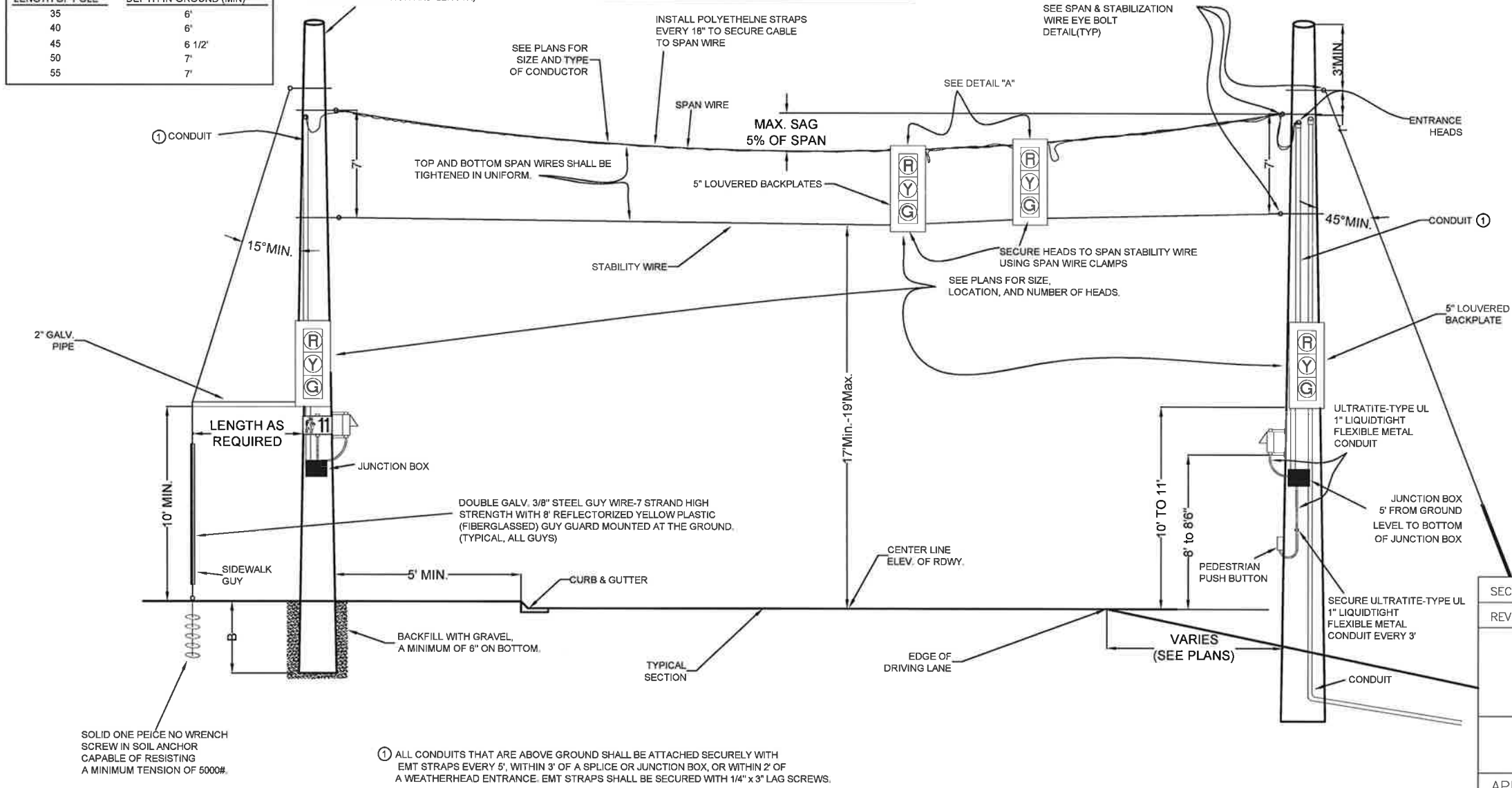

- NOTES:
1. THE INTERIM TRAFFIC SIGNAL SHALL MEET THE REQUIREMENTS AS STATED IN THE N.D. STANDARD SPECIFICATION SECTION 772 AND 896.
  2. IF A GUY WIRE ANGLE OF LESS THAN 45 DEGREES IS USED, THE CAPABILITY OF THE EXPANDING SOIL ANCHOR TO RESIST TENSION ON SITE MUST BE INCREASED.
  3. THE CONTRACTOR SHALL MAINTAIN THE REQUIRED 17 TO 19 FEET SIGNAL HEIGHT OVER THE ROADWAY FOR A MINIMUM PERIOD OF 90 CALENDER DAYS AFTER THE FINAL ACCEPTANCE DATE, UNLESS WRITTEN PERMISSION IS GRANTED THE ENGINEER TO WAIVE THE 90 DAY REQUIREMENT. THE COST OF MAINTAINING THE SIGNAL HEAD ELEVATION SHALL NOT BE BID SEPARATELY BUT SHALL BE INCLUDED IN THE PRICE BID FOR INTERIM SIGNALS.
  4. TRAFFIC SIGNAL CONTROLLER SHALL BE OPERATED ON 120 VOLTS.
  5. ALL SPAN WIRE & STABILITY WIRE SHALL HAVE THIMBLE TYPE CONNECTIONS.
  6. ALL POLE MOUNTED VEHICLE HEADS, PEDESTRIAN HEADS, AND PUSH BUTTONS SHALL USE 1" ULTRATITE-TYPE UL LIQUIDTIGHT FLEXIBLE METAL CONDUIT TO RUN WIRE FROM THE POLE MOUNTED HEAD OR BUTTON TO THE JUNCTION BOX. CONTRACTOR SHALL USE ALL METAL CONDUIT FITTINGS TO ENTER THE HEAD OR BUTTON AND FROM THE BOTTOM CONTRACTOR SHALL USE ALL METAL CONDUIT FITTING TO ENTER THE JUNCTION BOX.

SECTION NO.	4200	DRAWING NO.	5.9
REV.D.	2015		
<b>INTERIM TRAFFIC SIGNAL DETAIL</b>			
CITY OF FARGO ENGINEERING DEPARTMENT			
APPROVED	<i>Jmg</i>	DATE	12-8-14

① ALL CONDUITS THAT ARE ABOVE GROUND SHALL BE ATTACHED SECURELY WITH EMT STRAPS EVERY 5', WITHIN 3' OF A SPLICE OR JUNCTION BOX, OR WITHIN 2' OF A WEATHERHEAD ENTRANCE. EMT STRAPS SHALL BE SECURED WITH 1/4" x 3" LAG SCREWS.

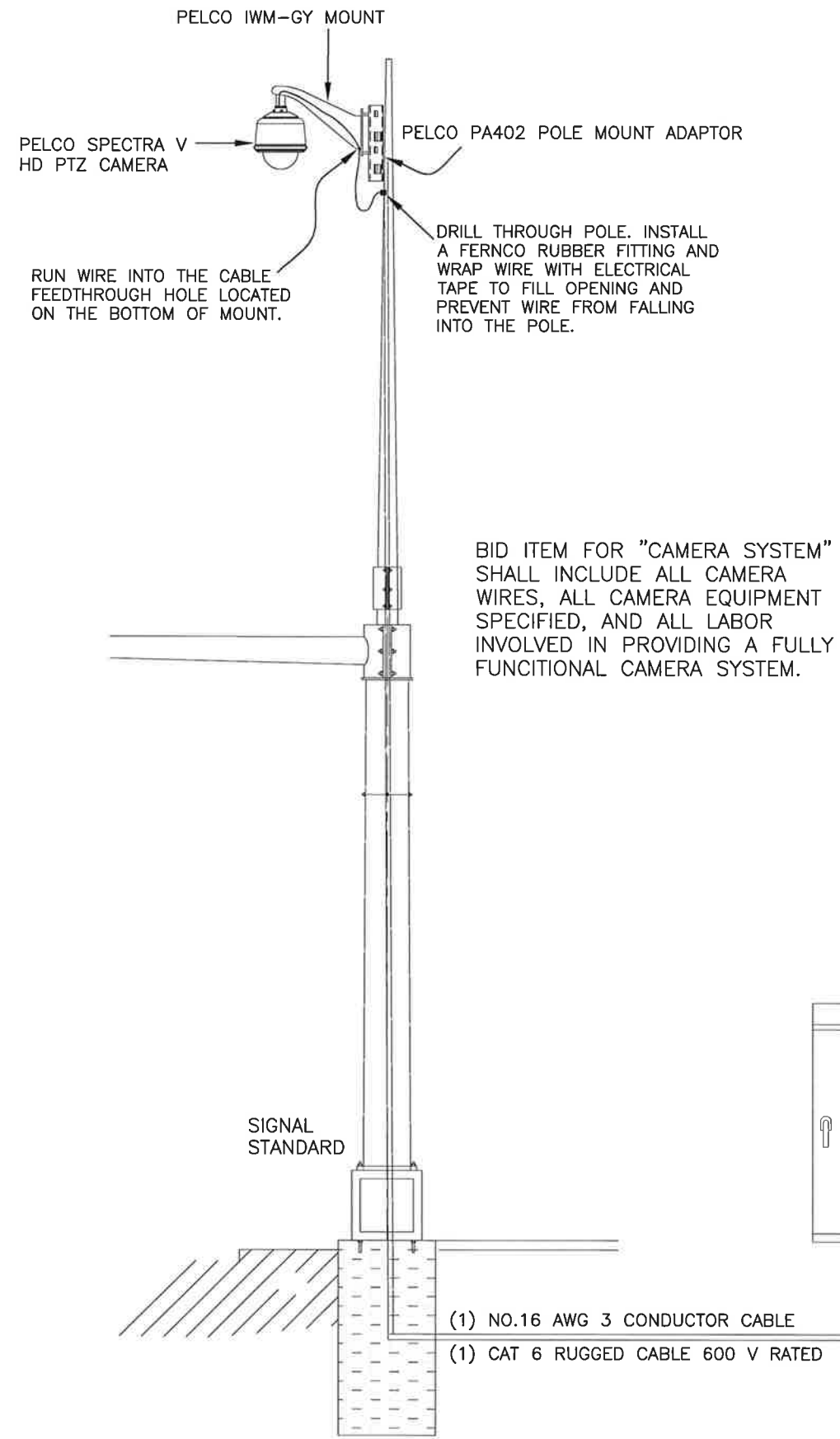

- CONTRACTOR SUPPLIED EQUIPMENT:**
- ETHERNET SWITCH AS SPECIFIED ON PLAN
  - CAT 6 RUGGED CABLE 600 V RATED
  - NO.16 AWG 3 POWER CABLE
  - PELCO IWM-GY MOUNT
  - 24 VAC POWER SUPPLY
  - PA402 POLE MOUNT
  - PELCO S5230-EG1 SPECTRA V HD NETWORK COLOR-B/W DOME WITH 30X OPTICAL ZOOM AND IMAGE STABILIZATION

## CAMERA SYSTEM

SECTION NO. 4200	DRAWING NO. 5.10
REV.D. 2015	
<b>TRAFFIC CAMERA DETAIL</b>	
CITY OF FARGO ENGINEERING DEPARTMENT	
APPROVED <i>Jmh</i>	DATE 12-8-14



**FIBER OPTIC BUFFER TUBE COLOR CODE**  
 MULTIMODE FIBERS 1-24/SINGLE MODE FIBERS 25-84

- 1. BLUE
  - 2. ORANGE
  - 3. GREEN
  - 4. BROWN
  - 5. SLATE
  - 6. WHITE
  - 7. RED
  - 8. BLACK
  - 9. YELLOW
  - 10. VIOLET
  - 11. ROSE
  - 12. AQUA
- INSTALL FAN OUT KIT ON ALL TERMINATED OR FIBER STRANDS WHEN TERMINATING THE FIBER OPTIC CABLE
- FIBER OPTIC CABLE:**  
 TUBE 1 = BLUE TUBE 1-12 MM FIBERS  
 TUBE 2 = ORANGE TUBE 13-24 MM FIBERS  
 TUBE 3 = GREEN TUBE 25-36 SM FIBERS  
 TUBE 4 = BROWN TUBE 37-48 SM FIBERS  
 TUBE 5 = SLATE TUBE 49-60 SM FIBERS  
 TUBE 6 = WHITE TUBE 61-72 SM FIBERS  
 TUBE 7 = RED TUBE 73-84 SM FIBERS

INSTALL PROTECTIVE TUBE SLEEVE AND TIE WRAP EACH TUBE TO SPLICE CASE.

**QUAZITE PULL BOX**

30" x 48" x 48"

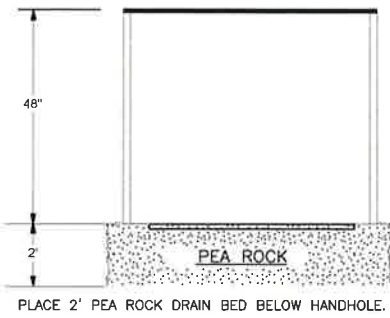

**TYCO ENCLOSURE**

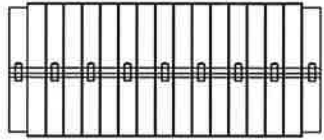

FIBER OPTIC ENCLOSURE SHALL BE A TYCO CLOSURE. FIBER OPTIC CABLES SHALL BE INSTALLED IN THE TYCO AS PER MANUFACTURE'S INSTRUCTIONS AND RECOMMENDATIONS. SEE COMMUNICATION CABLE SPECIFICATION NOTES FOR FURTHER INSTRUCTIONS.

**6-FIBER COMPATIBLE ST CONNECTOR PANEL**

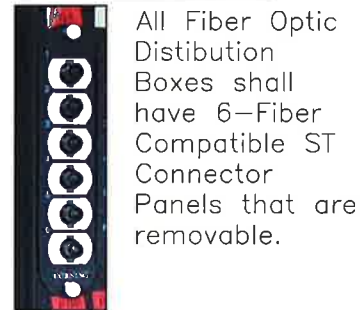

**FIBER DISTRIBUTION PANEL**

**EAGLE EPAC CONTROLLER**

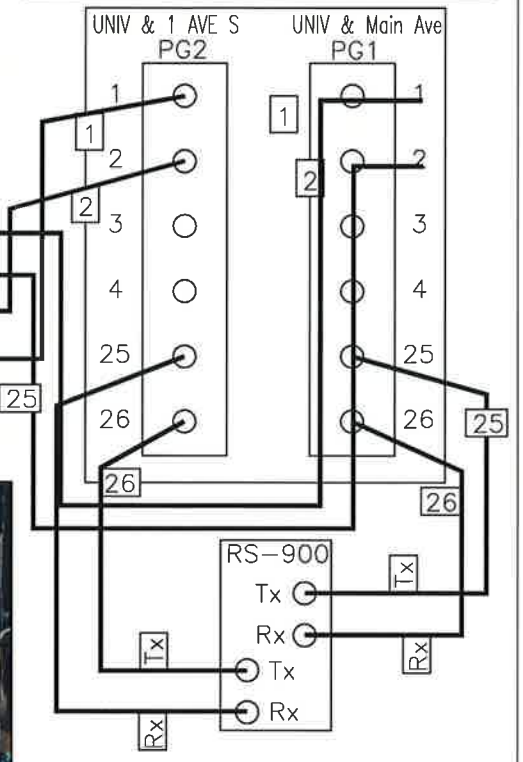

**FIBER OPTIC STAR MODEM**

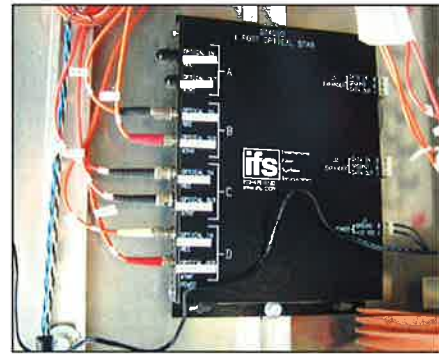

LABEL STAR MODEM 1-8.

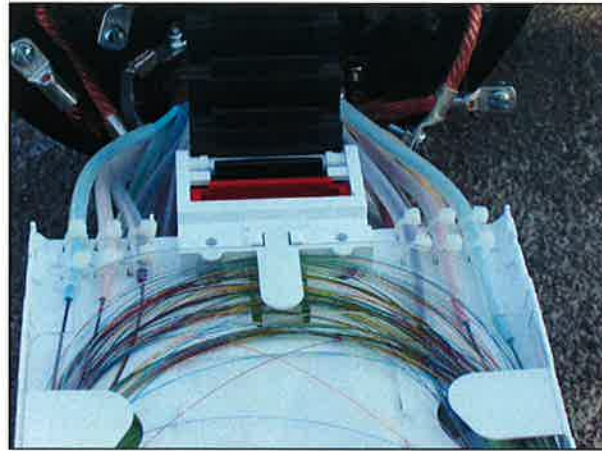

LABEL FIBER

3' OF FIBER SLACK

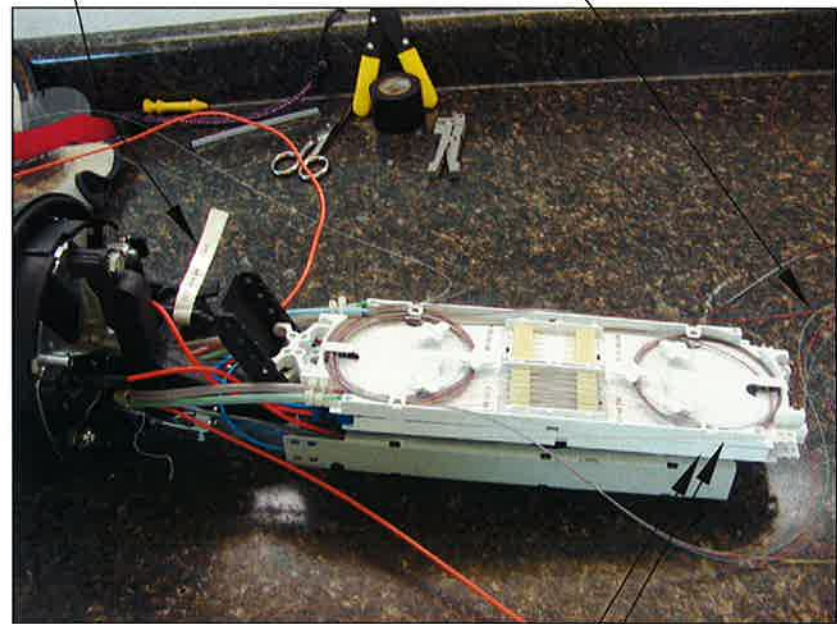

SEPARATE SPLICE TRAY FOR EVERY 2 TUBES OF FIBER INCLUDING NON-SPLICED FIBER TUBES

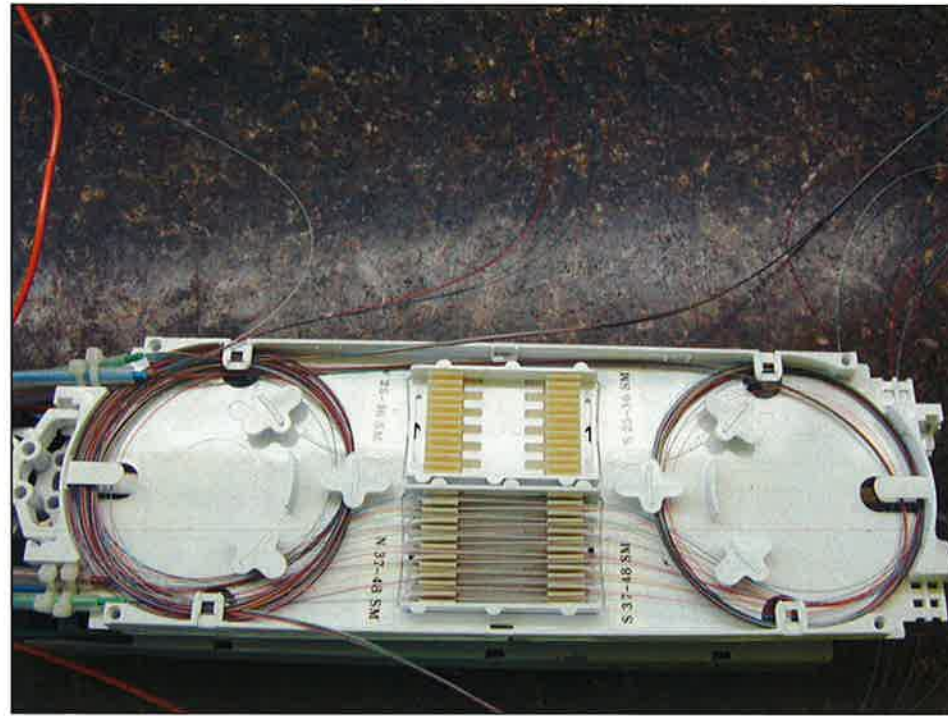

HEAT TUBE FUSION SPLICE HOLDERS SHALL BE MANUFACTURED BY TYCO ELECTRONICS PART # SMOUV-1120-01-US.

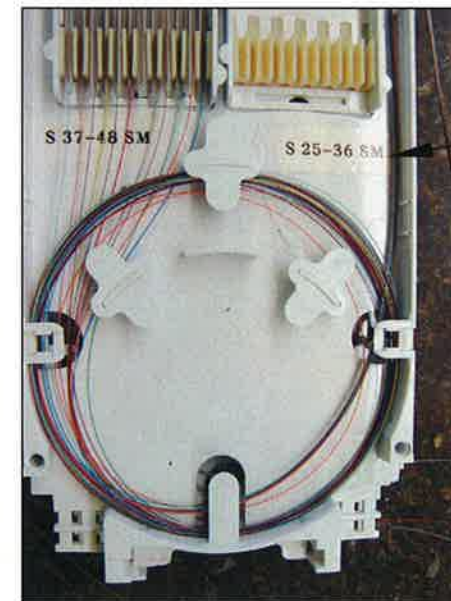

FIBER SHALL BE NEATLY INSTALLED IN SPLICE CASE AND LABELED.

ALL FIBER CABLES SHALL BE LABELED INSIDE AND OUTSIDE THE TYCO CASE AND SHALL BE COLOR CODE AS FOLLOWS:  
 NORTH=ORANGE  
 EAST=GREEN  
 SOUTH=BROWN  
 WEST=SLATE

SECTION NO.	4200	DRAWING NO.	5.11
REV.D.	2015		
<b>FIBER OPTIC DETAIL</b>			
CITY OF FARGO ENGINEERING DEPARTMENT			
APPROVED	<i>Jmg</i>	DATE	12-8-14

**CITY OF FARGO SPECIFICATIONS  
SIGNING**

**PART 1  
DESCRIPTION OF WORK**

The work to be done under this section of the Specifications and the accompanying plans consists of furnishing all labor, material and accessories necessary to complete the installation of signage in the City of Fargo.

**PART 2**  
**MATERIALS**

All materials furnished and used for this project shall be new and shall meet the City of Fargo Details. The traffic control sign details not otherwise specified shall meet the current edition of the Manual of Uniform Traffic Control Devices, published by the FHWA. All sign faces shall be according to the detail drawings and the alphabets shown in the MUTCD, Standard Highway Signs, and Standard Alphabets, published by FHWA.

2.1. FLAT SHEET ALUMINUM

Flat sheet aluminum shall be an alloy meeting ASTM B 209 Alloy 6061 T6, or 5052-H38 with mill finish. Both mounting holes on the sign shall be 3/8" in diameter to fit a 3/8" bolt.

2.2. HARDWARE AND FITTINGS

*2.2.1 Post Mounting Hardware*

All steel bolts, nuts, U-bolts, lock washers, and washers shall be galvanized steel meeting ASTM A153.

*1. Bolts*

3/8" diameter steel panel bolts, machine bolts, etc., shall meet SAE J429 Grade 5 or ASTM A449.

*2. Nuts*

Steel hex nuts shall meet SAE J995 Grade 5 or ASTM A563.

*3. Washers*

Steel flat washers shall be fabricated of steel meeting ASTM F844. Plastic washers shall be fabricated to the sheeting manufacturer's specifications.



*2.2.2. Light Standard Mounting Hardware*

1. *Bolts*

Stainless Steel hex bolts, 1/4" diameter

2. *Self-Tapping Screws*

1/4" Self Tapping Screws with hex head and locking flange

3. *Washers*

Steel flat washers shall be fabricated of steel meeting ASTM F844. Plastic washers shall be fabricated to the sheeting manufacturer's specifications.

2.3. POSTS

Posts shall be Telespar 12 gauge brand.

## **PART 3 CONSTRUCTION**

### 3.1. PRE-CONSTRUCTION SIGN RECONNAISSANCE

All existing sign posts shall be assumed to be straight and in good condition. The Contractor should verify all signage within the project limits is straight and in good condition. Before starting work, the Contractor will provide the project Engineer with a list of any damaged posts or signs. Upon substantial completion of the contract, the signs that were not on the list provided by the Contractor pre-construction but were damaged during the construction activity will be assumed to have been damaged by the Contractor and is his responsibility to replace any damaged signs to City of Fargo Standards and Specifications.

The Contractor has the responsibility of protecting all existing street signs and their supports from damage during the course of this project. The Contractor will replace and install with new all damaged signs and their supports at their own expense. In the event that they are temporarily removed during the project the City of Fargo will provide locations for them to be replaced in their original location.

### 3.2. LOCATING AND POSITIONING SIGNS

Each sign shall be located according to the plans. Installed signs will be inspected at night for maximum effect. If any sign is ineffective at night, the sign shall be replaced at the Contractor's expense.

### 3.3. SIGN FABRICATION, PACKAGING, LABELING, HANDLING, AND SHIPPING

All sign fabrication, packaging, labeling, handling, and shipping shall follow the latest version of the NDDOT Standard Specifications for Road and Bridge Construction.

### 3.4. ANCHOR FOR TELESCOPING PERFORATED TUBES SUPPORTS

#### *3.4.1. Boulevard Sign Placement (Detail 5.2)*

Anchors and Anchor Sleeves for telescoping perforated tubes supports shall be driven. The perforated tube anchor and sleeve shall be driven to a height of 5-6 inches above the ground. Anchors and Sleeves shall be installed per detail. Telescoping Tube posts will

not be a pay item; it will be incidental to the “Sign Assembly” bid items. It is the Contractor’s responsibility to install the sign assembly to the required height.

*3.4.2. Concrete or Asphalt Sign Placement (Detail 5.3)*

STOP and YIELD sign anchors and anchor sleeves for telescoping perforated tubes supports shall be driven. The perforated tube anchor and sleeve shall be driven to a maximum of 5-6 inches above the sidewalk or asphalt surface. Anchors and Sleeves shall be installed per detail. If the sidewalk is installed prior to sign installation, it shall be cored to install the anchor and sleeve unit and the cored area shall be filled with pea rock to restore the sidewalk surface. If the sign is existing and the sidewalk is being poured around an existing base, a sleeve of 4 inch diameter shall be used around the base to prevent concrete from contacting the sign post. Telescoping Tube posts will not be a pay item; it will be incidental to other “Sign Assembly” bid items. It is the Contractor’s responsibility to install the sign assembly to the required height.

All other signs posts installed in concrete areas shall be surface mounted with a Kleen Break model 425 concrete surface mount sign post coupler. Sign post shall be mounted level and be secured tightly in Kleen Break system.

3.5. MOUNTING FLAT SHEET SIGNS

Flat sheet signs shall be bolted to the post or light standard, and shall have a nylon washer between the flat washer and the sign face.

3.6. REMOVING AND RESETTING SIGNS AND SIGN ASSEMBLIES

Existing signs and sign assemblies shall be removed or reset as specified. All signs and sign assemblies not to be reset shall be defaced and shall become property of the Contractor and Contractor shall be responsible for discarding items. Removed or reset signs and sign assemblies that become damaged during removing, resetting, or stockpiling shall be replaced at the Contractor’s expense. Existing signs and sign assemblies shall be removed as construction progresses, and shall be immediately reset or installed. The Contractor shall install new signs or reset signs as shown on the Plans. Any damaged signs or sign assemblies shall be replaced at the Contractor’s expense.

3.7. BREAKAWAY BASES

Breakaway bases for telescoping tubes will not be allowed on any City of Fargo construction projects for any STOP or YIELD sign installation or any other sign installed that is installed in a non-concrete/asphalt area. A Kleen Break model 425 sign post coupler will be required for all signing in concrete/asphalt surface areas excluding STOP/YIELD signs.

## **PART 4 GUARANTEE, MEASUREMENT & PAYMENT**

### 4.1. GUARANTEE

The guarantee shall be per the contract.

### 4.2. MEASUREMENT & PAYMENT

#### *4.2.1. SIGN PANELS*

Flat sheets and panels will be paid to the closest 1/10 square foot, based on the largest measurement, horizontally and vertically as set forth in the latest edition of the Standard Highway Signs Manual published by the FHWA. All hardware, stringers, and brackets required to attach signs to the posts shall be included in the pay item.

##### 4.2.1.1. EG Signs

This item shall be paid for at the contract unit price per square foot and shall include the cost to supply “Engineering Grade” sheeting and aluminum panel. The size of each sign shall be as shown on the plans.

##### 4.2.1.2. HIP Signs

This item shall be paid for at the contract unit price per square foot and shall include the cost to supply “High Intensity Prismatic” sheeting and aluminum panel. The size of each sign shall be as shown on the plans.

##### 4.2.1.3. DG3 Signs

This item shall be paid for at the contract unit price per square foot and shall include the cost to supply “DG Cubed” sheeting and aluminum panel. The size of each sign shall be as shown on the plans.

#### *4.2.2. INSTALL SIGN ASSEMBLY (POST)*

This item shall be paid for at the contract unit price per each, and shall include the cost to supply and install the sign support, reinforcement sleeve, and soil anchor in accordance

with the detailed drawings. The post and anchor shall be manufactured of Telespar 12 gauge square perforated tube of the size shown on the detail. The Contractor shall verify the proper length required to provide the required vertical clearance.

#### *4.3. INSTALL SIGN ASSEMBLY (LIGHT STANDARD)*

This item shall be paid for at the contract unit price per each, and shall include the cost to supply and install the sign hardware and drilling and using self tapping screws for the mounting of signs on new or existing light standards.

#### *4.4. INSTALL TYPE III BARRICADE*

This item shall be paid for at the contract unit price per each, and shall include the cost to supply and install (2) sign supports, (2) reinforcement sleeves, and (2) soil anchors in accordance with the detailed drawings. The post and anchor shall be manufactured of Telespar 12 gauge square perforated tube of the size shown on the detail. The Type III Barricade Rail is incidental to the installation of the Type III Barricade. Any sign mounted on the Type III Barricade shall be paid in accordance with section 4.2.1. The Contractor shall verify the proper length required to provide the required vertical clearance.

#### *4.5. RELOCATE SIGN ASSEMBLY*

This item shall be paid for at the contract unit price per each, and be measured by the number of locations at which a sign assembly has been reset. A sign assembly consists of the sign, post, sleeve, anchor and mounting hardware for post mounted signs. A sign assembly consists of mounting hardware and sign face for light standard mounted signs. Signs and assemblies will be counted in place and accepted by the Engineer.

#### *4.6. REMOVE SIGN ASSEMBLY*

Removed signs and sign assemblies will not be measured for payment as they are incidental to the project.

*4.7. OTHER COSTS*

All other costs for work necessary to properly complete the work specified herein shall not be bid items; the costs shall be charged to other items unless a bid item is specifically included on the bid sheet.

VERTICAL CLEARANCE
7' FOR SINGLE SIGN
6' FOR DOUBLE SIGN

SIGN SIZE	SIGN THICKNESS
≤ 24" (& 30" STOP SIGNS)	80 GA.
> 24" (EXCEPT 30" STOP SIGNS)	100 GA.

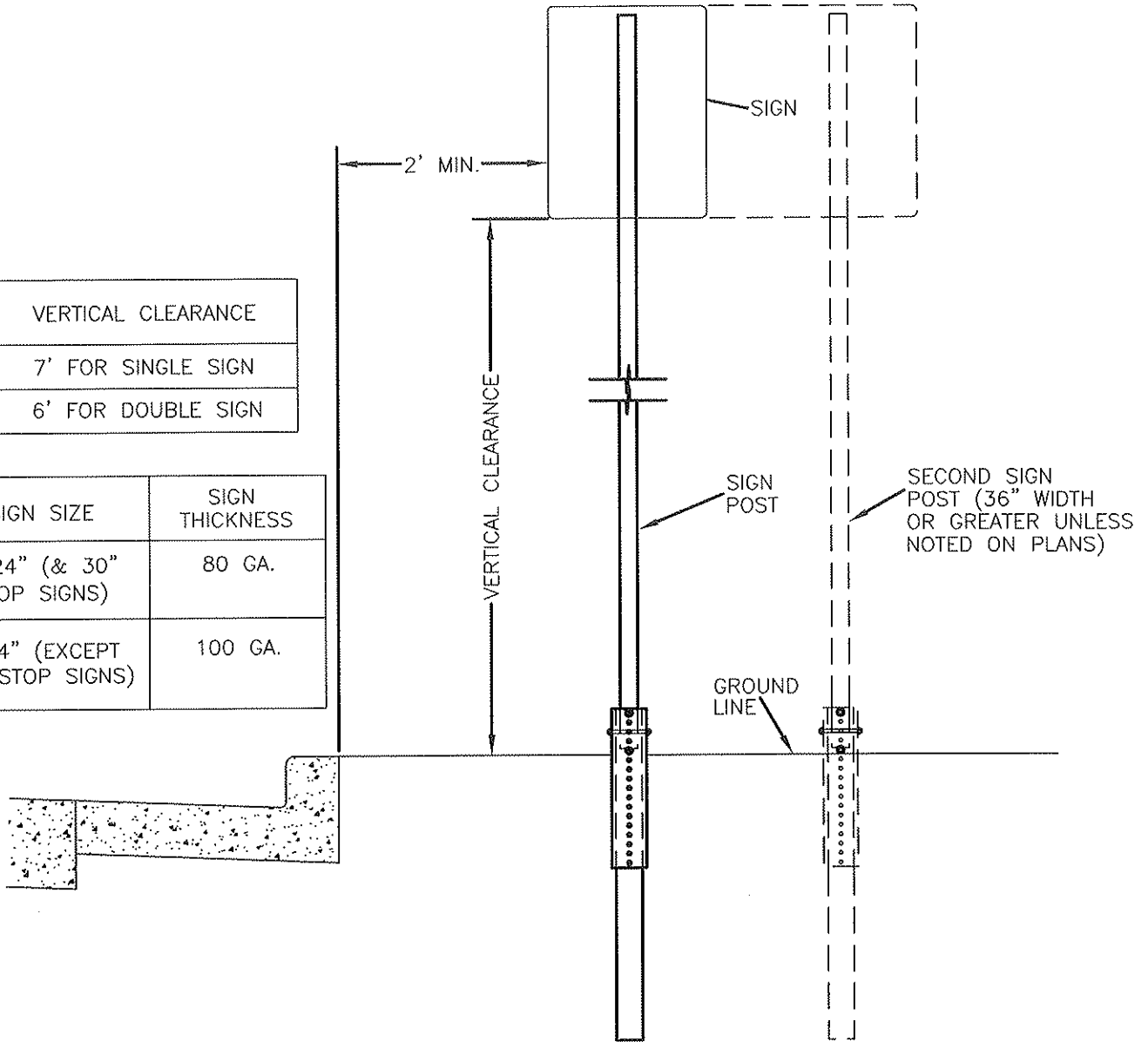

DATED SIGN TAGS ALL NEW SIGNS THAT ARE INSTALLED SHALL HAVE A DATED TAG INSTALLED ON THE BACK OF THE SIGN, SHOWING THE CONTRACTORS LOGO, MONTH AND THE YEAR THAT THE SIGN WAS INSTALLED. THE DATE SHALL BE SHOWN BY REMOVING THE CORRECT MONTH AND YEAR WITH A HOLE PUNCHER. THIS SHALL BE INCIDENTAL TO THE COST OF THE SIGN.

SECTION NO. 4300	DRAWING NO. 5.1
REV, D.	
<b>SIGN ASSEMBLY</b>	
CITY OF FARGO ENGINEERING DEPARTMENT	
APPROVED JAD	DATE 1/2/2013



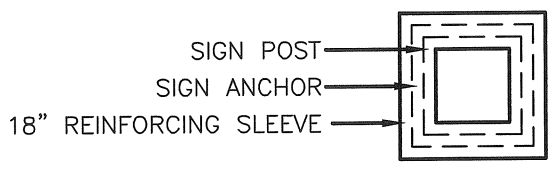
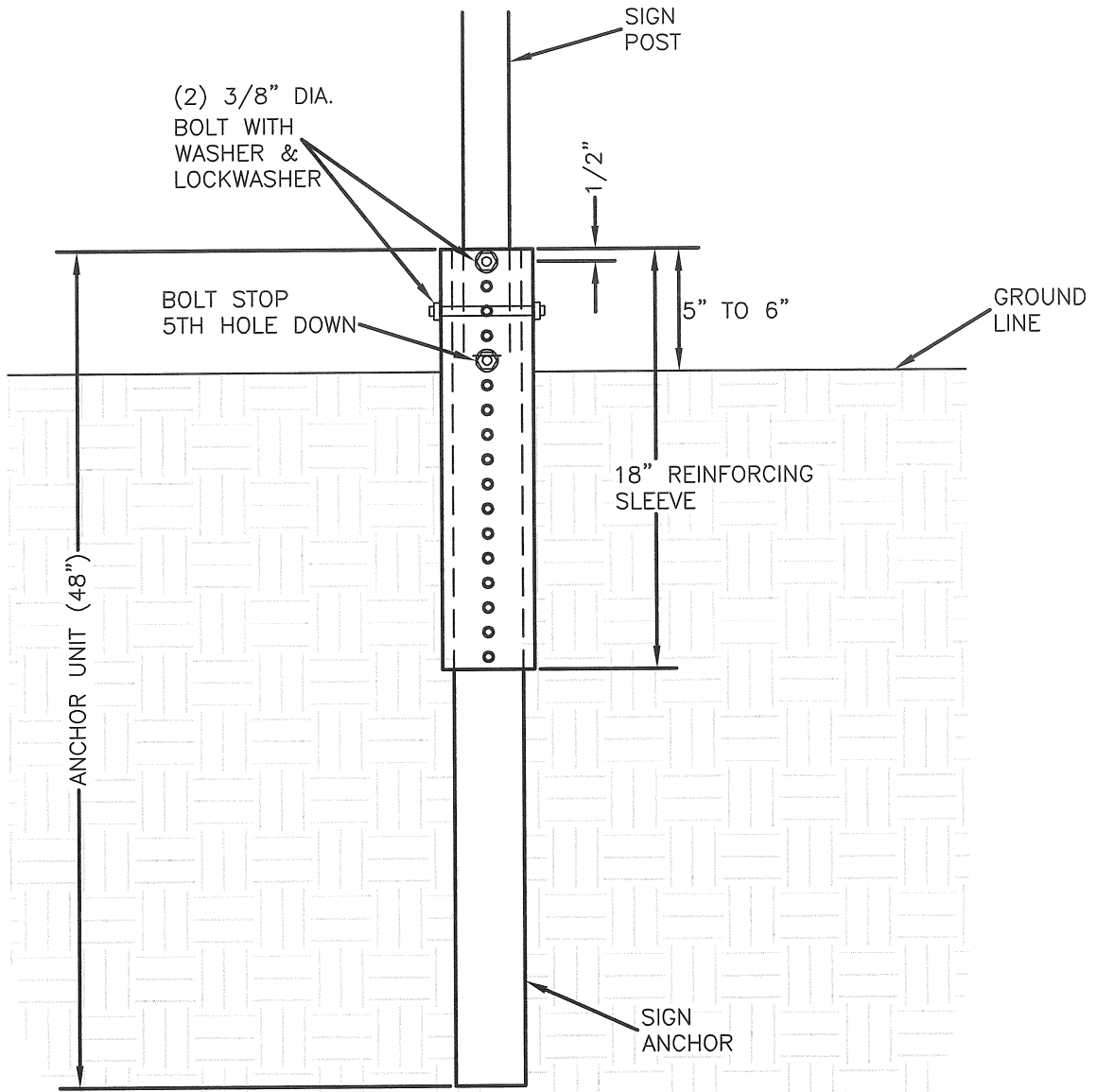

NOTE: REINFORCING SLEEVE TO BE USED ON ALL SIGNS

SIGN SIZE	POST	ANCHOR	SLEEVE
12" WIDTH SIGNS	1.50"	1.75"	2.00"
18" WIDTH SIGNS & 24"x24" SIGNS	1.75"	2.00"	2.25"
LARGER THAN 24"x24"	2.00"	2.25"	2.50"

SECTION NO. 4300	DRAWING NO. 5.2
REV.D.	
<b>SIGN ANCHOR BLVD INSTALLATION</b>	
CITY OF FARGO ENGINEERING DEPARTMENT	
APPROVED <i>BEO</i>	DATE <i>2-21-2012</i>

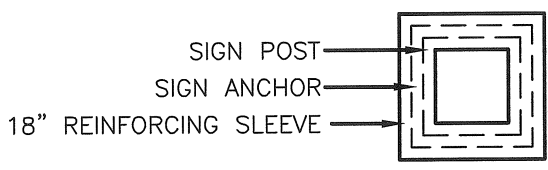
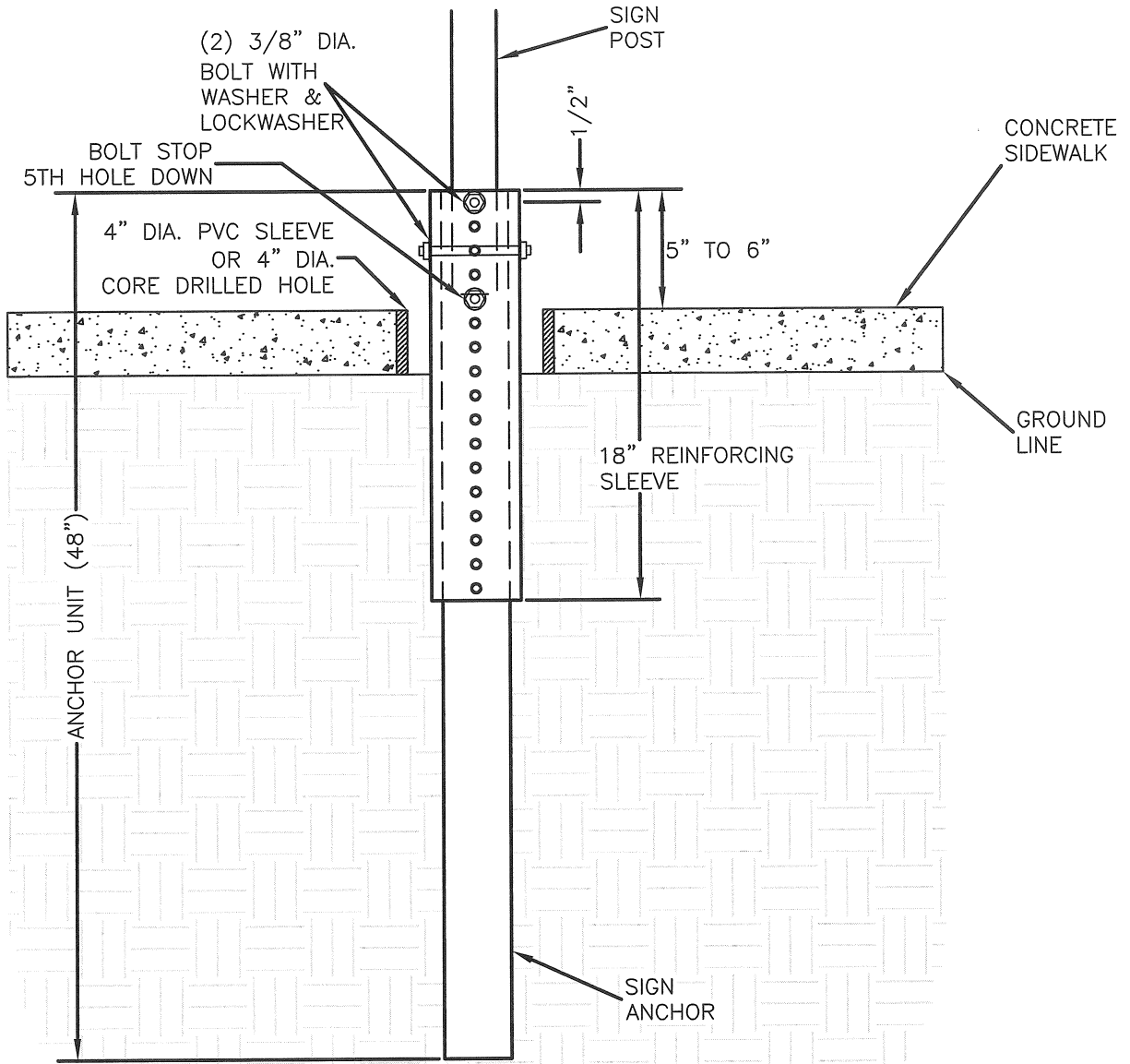

NOTE: REINFORCING SLEEVE TO BE USED ON ALL SIGNS

SIGN SIZE	POST	ANCHOR	SLEEVE
12" WIDTH SIGNS	1.50"	1.75"	2.00"
18" WIDTH SIGNS & 24"x24" SIGNS	1.75"	2.00"	2.25"
LARGER THAN 24"x24"	2.00"	2.25"	2.50"

SECTION NO. 4300	DRAWING NO. 5.3
REV,D.	
<b>SIGN ANCHOR SIDEWALK INSTALLATION</b>	
CITY OF FARGO ENGINEERING DEPARTMENT	
APPROVED <i>BED</i>	DATE <i>2-21-2012</i>

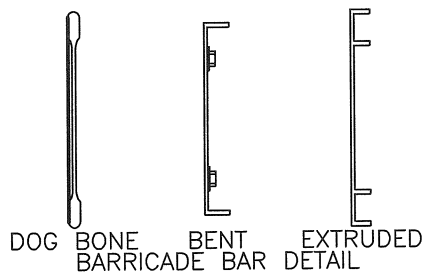
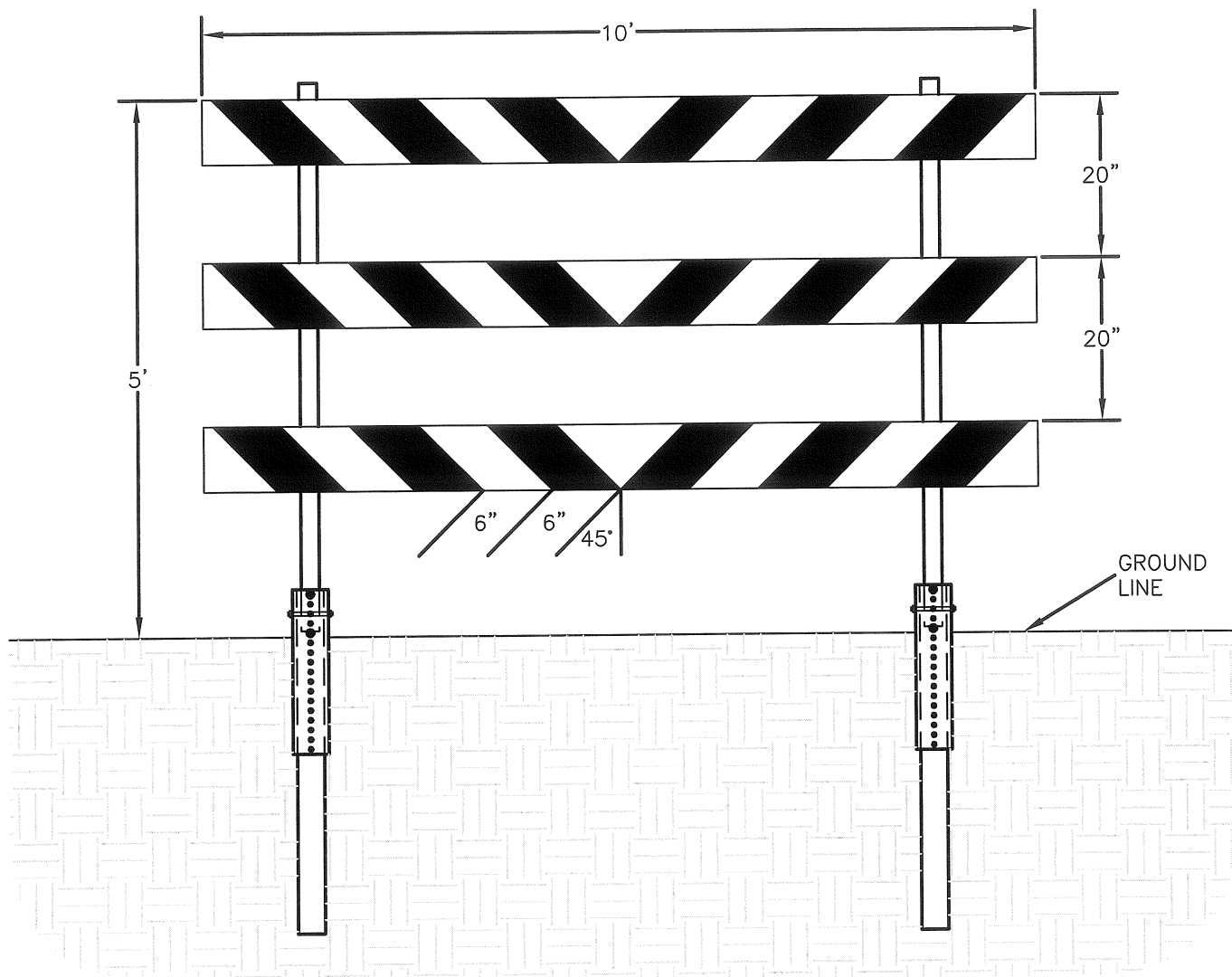

BARRICADE RAILS SHALL BE 8" OR 9" X 120".  
 SHEETING MATERIAL SHALL BE DG3 SHEETING, ALTERNATING RED AND WHITE AT A 45° ANGLE.  
 TYPE III BARRICADE SHALL CONFORM TO THE LATEST EDITION OF THE MUTCD.

SECTION NO. 4300	DRAWING NO. 5.4
REV.D.	
<b>TYPE III BARRICADE</b>	
CITY OF FARGO ENGINEERING DEPARTMENT	
APPROVED <i>BEO</i>	DATE <i>2-21-2012</i>

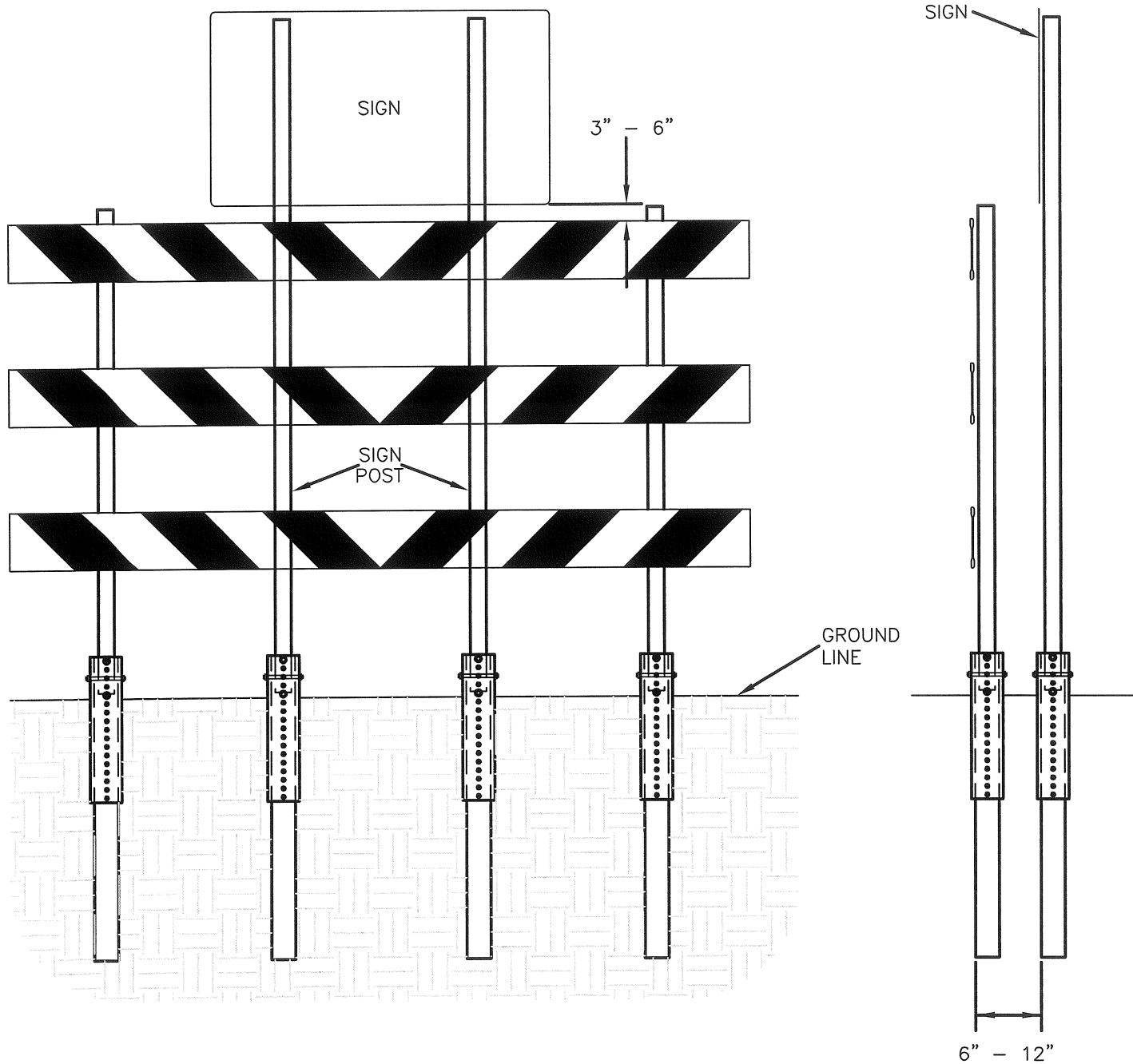

SECTION NO. 4300	DRAWING NO. 5.5
REV. D.	
<b>SIGN ADJACENT TO BARRICADE</b>	
CITY OF FARGO ENGINEERING DEPARTMENT	
APPROVED <i>BED</i>	DATE <i>2-21-2012</i>

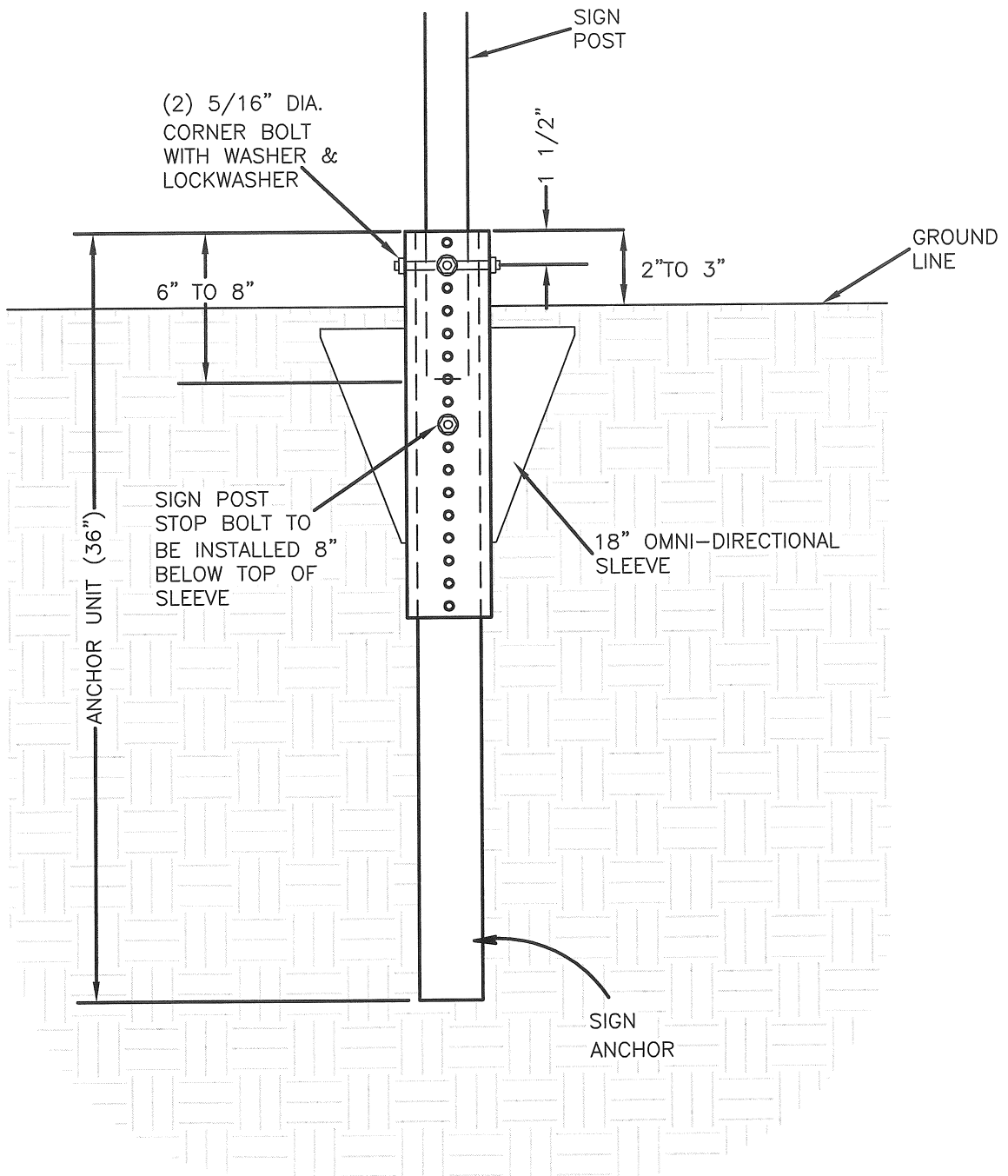

NOTE: OMNI-DIRECTIONAL SLEEVE W/4 BLADES TO BE USED ON STREET DESIGNATION SIGNS

SECTION NO. 4300	DRAWING NO. 5.6
REV.D.	
<b><i>STREET DESIGNATION ANCHOR INSTALLATION</i></b>	
CITY OF FARGO ENGINEERING DEPARTMENT	
APPROVED <i>BED</i>	DATE <i>2-21-2012</i>

STREET DESIGNATION SIGNS

All street designation signs shall utilize 9" 80 gauge flat aluminum, 24" or longer (in 3" increments), depending on the space needed.

The signs shall have 6" series "B" upper case letters with 4 1/2" lower case format and a 1/2" border.

The sign sheeting shall be 3M Series 4090 DG sheeting and any processed colors, inks, or electronic cuttable film shall be a matched component system. All Street Desig. Signs shall have a 9' clearance to bottom of sign. The following are examples of the sign format.

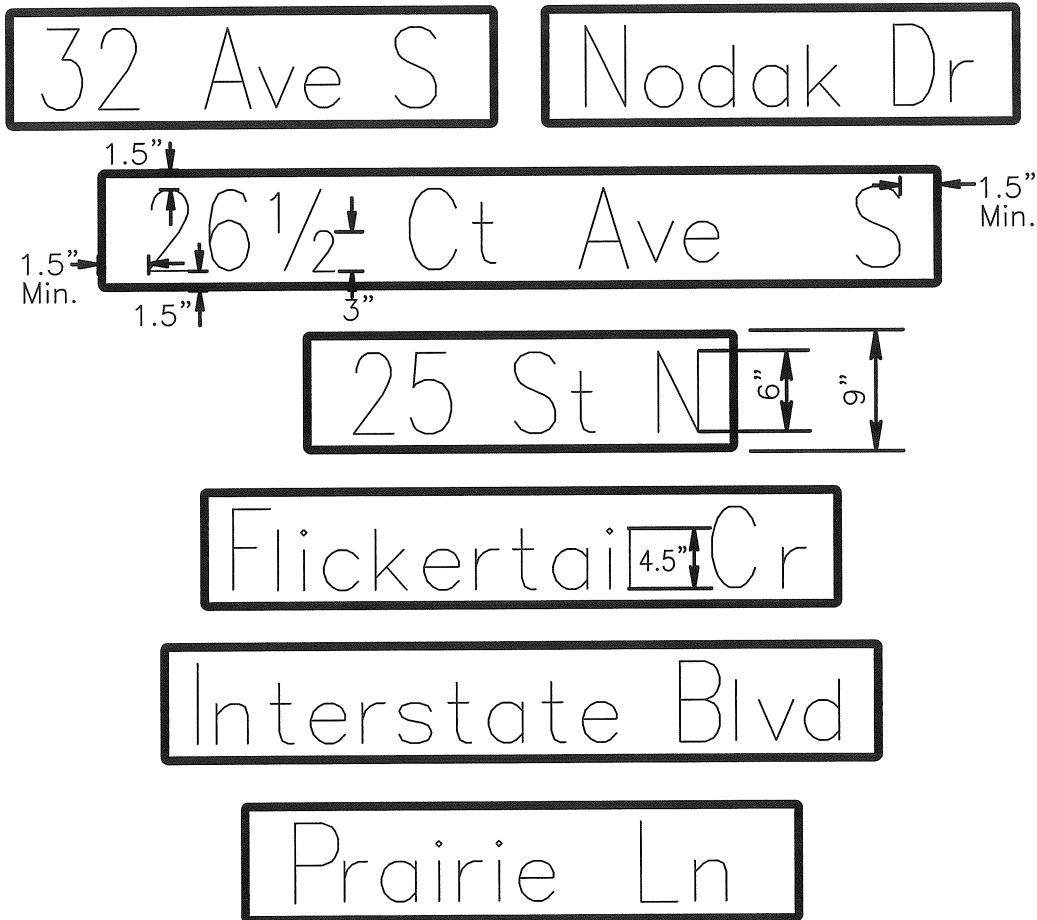

SECTION NO. 4300	DRAWING NO. 5.7
REV.D.	
<b>STREET DESIGNATION SIGN INSTALLATION</b>	
CITY OF FARGO ENGINEERING DEPARTMENT	
APPROVED <i>BED</i>	DATE <i>2-21-2012</i>

MAST ARM MOUNTED STREET DESIGNATION SIGNS

All mast arm mounted street designation signs shall utilize 18" 100 gauge flat aluminum, 48" or longer, depending on the space needed.

The signs shall have modified "E" series letters with a 12" upper and 9" lower case format and a 1" sign border.

The sign sheeting shall be 3M series 4090 DG sheeting, and any processed colors, inks, or electronic cuttable film shall be a matched component system.

The following are examples of the sign format.

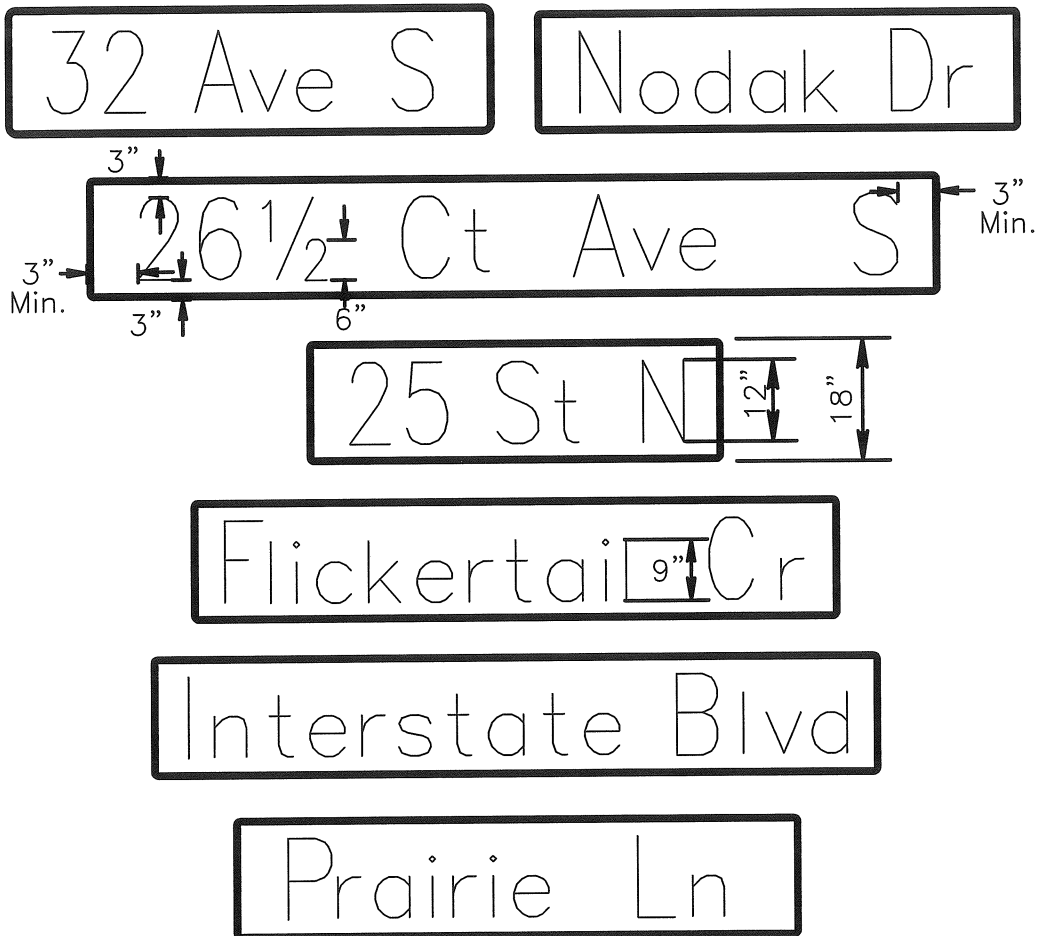

SECTION NO. 4300	DRAWING NO. 5.8
REV.D.	
<b><i>STREET DESIGNATION MAST ARM INSTALLATION</i></b>	
CITY OF FARGO ENGINEERING DEPARTMENT	
APPROVED <i>BED</i>	DATE <i>2-21-2012</i>

**CITY OF FARGO SPECIFICATIONS  
STREET LIGHTING**

**PART 1  
DESCRIPTION OF WORK**

The work to be done under this section of the Specifications shall consist of furnishing and installing a complete and operational street lighting system.



**PART 2**  
**MATERIALS**

**2.1. GENERAL**

The Contractor shall furnish the specified material unless substitute materials are approved in writing by the Engineer.

**2.2. RIGID CONDUIT**

**2.2.1. NONMETALIC CONDUIT**

Nonmetallic conduit shall be 1.5” high-density polyethylene (HDPE) innerduct unless otherwise shown on Plans. Polyvinyl chloride (heavy wall – PVC) will be allowed in certain situations with written approval from the project Engineer.

**2.2.1.1. HDPE.** HDPE innerduct shall meet the requirements of UL 651 and either ASTM 2447 or ASTM 3035 suitable for direct burial applications. HDPE innerduct shall have a minimum wall thickness equivalent to Schedule 40 as defined by ASTM 2447 or DR 15.5 as defined by ASTM 3035. HDPE innerduct shall not be installed when either the innerduct temperature or ambient temperature is below –10 F.

**2.2.1.2. PVC.** PVC conduit shall meet the requirements of UL 651 suitable for direct burial applications and shall have a minimum wall thickness equivalent to Schedule 40 as defined by ASTM 1785.

**2.3. CONDUCTORS**

**2.3.1. UNDERGROUND CONDUCTORS**

Underground circuit conductors shall be stranded copper, Type “USE”, conductors insulated for direct burial and rated 600 volts. Conductor sheath shall be marked as to voltage, AWG, type (USE), and manufacturer. All conductor shall be continuous color coded (red, black and green). Conductors shall be of the size shown on the Plans.

**2.3.2. STREET LIGHT STANDARD CONDUCTOR**

The conductor required for the street light standards between distribution conductors and luminaire shall consist of No. 10 AWG stranded copper, Type "USE" and rated 600 volts. Street Light fuses shall be a type FNM 10 amp fuse with a Bussmann type HEB-AA or a Littlefuse type LEB-AA in line fuse holder. Provide ground conductor from the luminaire to the handhole where required by the national electrical code.

**2.4. SPLICE CONNECTIONS**

Splice connections in street light bases shall be Tyco Electronics GelCap SL splice cover kit with connector. All other conductor splice connections in pull boxes and feed points shall be UL listed, with PowerGel sealant type connections meeting all codes for desired applications.

**2.5. PULL BOX****2.5.1. PVC PULL BOX**

Unless otherwise noted on plan, all street light pull boxes shall be PVC with metal frames and covers, and shall conform to the detail included in the plans. Pull boxes in landscaped areas shall have the top of the box 0" to 1" above final grade and sloped to match the slope of the final grade on all 4 quadrants. Pull boxes in concrete area shall be set with the top of the box flush with the final grade at all 4 quadrants.

**2.5.2. POLYMER CONCRETE PULL BOX**

The minimum size shall be 11" x 18" x 24" deep, with no base. The cover will be 1-3/4" thick, secured with stainless steel bolts, and have a logo of "Street Lights". The base and cover shall be made from a polymer concrete material able to sustain a minimum test load of 12,000#. Color shall be green or gray depending upon location of installation. Carson and Quazite brands are approved for installation.

**2.6. FEED POINT**

Pedestal type feed point shall be concrete pad mounted (see Plans for size of cabinet and number of circuits). The pedestal cabinet shall have a NEMA 3R rating. The cabinet shall be constructed of 16 gauge #304 stainless steel, stainless steel hardware and a padlockable stainless steel handle with 3-point latch operation, continuous hinged deadfront, 2" drip shield, gasketed lexan photocell window on side and back

of pedestal cabinet. All circuit breakers shall be rated 22,000 AIC. The pedestal cabinet shall also include a factory installed, interior mounted meter trim which meets the size requirements of the local utility company and a viewport window with gasketed lexan located on the front door of pedestal cabinet. Meter shall be provided by the local utility company.

Prefabricated feed point enclosure to be assembled by States Electric, UL 508 listed, service entrance rated, or approved equal.

**2.7. STREET LIGHTING STANDARDS**

Refer to Plans for information on size and type of standards.

**2.8. STREET LIGHTING LUMINAIRES**

Refer to Plans for information on size and type of luminaires.

**2.8.1. Lamps**

All High Pressure Sodium lamps shall be eco style, no cycle lamps. Contractor shall supply and install all lamps.

**PART 3  
CONSTRUCTION**

**3.1. GENERAL**

**3.1.1. GENERAL**

All work and material shall meet the National Electric Code, the North Dakota State Electrical Board, the local utility company, and the ordinances established by the City of Fargo. All materials shall be new.

**3.1.2. SHOP DRAWINGS**

The Contractor shall provide an electronic PDF file of shop drawings and certifications required by the City of Fargo within 15 days of the Notice to Proceed sent out after the City Commission has approved the Project. All shop drawings and certifications shall be approved prior to any work being started. A list of required shop drawings will be provided to the Contractor by the Engineer upon request.

The Contractor shall be responsible for the accuracy of the shop drawings. The Engineer's review does not relieve the Contractor of full responsibility for providing a quality product that meets Specifications. The Contractor shall submit shop drawings on the following listed items for approval:

1. Conductors
2. Pull Box
3. Feed Point: cabinet, relays, switches, panels and photo cells.
4. Street Light Standards, including all necessary calculations and drawings used in designing these poles.
5. Street Light Luminaires
6. Items requested by Engineer

**3.1.3. WARRANTIES AND GUARANTEES**

All manufacturer warranties and guarantees with respect to materials, parts, workmanship, or performance which the products covered by the proposal bear shall be secured and included with the shop drawing submittal.

**3.1.4. COORDINATION**

The Contractor shall coordinate all work with the City's project Engineer and/or inspector when work activities are scheduled. The electrical Contractor is responsible to coordinate his activities with the underground, paving and landscape Contractors to insure the timely completion of the new street lighting system.

**3.1.5. LOCATION OF EXISTING UTILITIES**

Partial existing utilities have been shown to direct the Contractor's attention to their existence. Such utilities have been plotted from record drawings.

THE CONTRACTOR IS CAUTIONED THAT ALL EXISTING UTILITIES MAY NOT BE SHOWN. THE LOCATION OF EXISTING UTILITIES IS NOT GUARANTEED, AND THE CONTRACTOR WILL BE RESPONSIBLE FOR DETERMINING THE EXACT LOCATION AND PROTECTION OF THE EXISTING UTILITIES. THE CONTRACTOR, BEFORE COMMENCING ANY EXCAVATION OR CONSTRUCTION, SHALL FIND OUT THE LOCATION AND SEEK AID IN LOCATING ALL PUBLIC AND PRIVATE UTILITIES. THE CONTRACTOR SHALL CONTACT ND ONE-CALL 1-800-795-0555 AND REQUEST LOCATES PRIOR TO BEGINNING CONSTRUCTION.

**3.1.6. OVERHEAD LINES CLEARANCE.** Minimum horizontal and vertical clearance between street light standards/luminaires and power lines shall be as shown for the following power line voltages:

Power Line Voltage	Horizontal Clearance	Vertical Clearance
0-15,000	5'	6'
15,000-50,000	5'	7'
50,000 Plus	5'+0.033' per KV	7'+0.033' per KV
	Over 50 KV	Over 50 KV

**3.2. CONSTRUCTION REQUIREMENTS**

If the Contractor has a delay in delivery of ordered materials that will affect the completion date of the project and The City of Fargo is able to provide materials for the Contractor to borrow, the Contractor shall borrow the materials from the City by supplying the project from the City's maintenance stock, then replenishing the maintenance stock once the delivery arrives.

**3.2.1. CONCRETE BASE**

See plans for detail of Concrete Base size requirements and construction requirements. It shall be the Contractors responsibility to verify shop drawing information, provided by the manufacturer of the street light standards, for anchor bolt size, bolt circle diameter and anchor bolt projections.

Column forms shall be used for the top 12" of base tops. Square top forms will not be allowed. Verify anchor bolt projection requirements. Conduit with bell end shall have a maximum height of 2" above concrete base surface and the ground rod shall be a maximum of 1-1/2" above conduit with bell end. Finish of the base top shall be level without any irregularities or depressions in the concrete. Grinding of base top or filling of depressions will not be allowed and any base not meeting these requirements will be removed and replaced at the Contractors expense. Column forms shall be removed as part of clean up before landscaping. Bases shall have a minimum seven day cure time before any standards shall be installed. Excess dirt from the drilling of base hole shall be removed from the project site daily.

Concrete shall be a 6 bag mix with a minimum 28-day compressive strength of 3500 p.s.i. Entrained air content shall be between 5% and 8%.

It is the Contractors responsibility to protect any concrete base left over winter. Any base damaged will be replaced at the Contractors expense.

**3.2.2. CONDUIT**

Innerduct shall be 1.5" schedule 40 innerduct, smooth outside, controlled outside diameter at 1.9000. Inside diameter of 1.579, minimum wall thickness of 0.145, and color RED, unless otherwise shown on plans.

Innerduct/conduit shall be installed at the location shown on the plans and will be connected to stubbed out 1.5" conduit at all concrete base and feed point locations. Installation of innerduct

shall be at a minimum depth of 24" below finished grade. The innerduct shall be placed in line with bases behind curb. Innerduct/conduit shall be bored under existing pavement (jacking will only be allowed under existing sidewalks and multi use paths) and in areas of mature trees, established sod and all others locations shown on plans.

All innerduct/conduit shall have Bell Ends installed on both ends of the innerduct/conduit run. All innerduct/conduit containing conductor/cables shall be sealed with duct seal at the feed point cabinets, pull boxes and at the street light standard bases. All spare conduits shall be plugged with an expanding rubber pipe plug at the feed point cabinet, pull boxes and street light standard bases.

### 3.2.3. CONDUCTORS

Conductors shall be continuous color coded (black, red and green). No splicing of conductors will be allowed without specific approval of ENGINEER. Conductors shall be of the size shown on the Plans.

All street lighting circuits shall be 240V single phase consisting of three conductors, black and red for the phase conductors and a green for the ground conductor.

Distribution circuits shall be routed as shown on plans. Any deviation in routing of circuits must be approved by the project Engineer.

Luminaire or festoon circuits are to be fused in the base of each lighting standard. Tape fuse holders with a 1/2-inch lapped layer for a distance of 1½ inches on each side of joint with conductor. Fuse holders to be complete with proper fuse to protect luminaire ballast. If required for a festoon circuit the neutral conductor shall be solidly connected and unfused throughout the system.

Ground conductors shall be bonded to standards by a ground lug and to the following by approved grounding methods per national electrical code, ground rod at standard base, feed point enclosure, feed point panels, relay cabinets and ground rods. A continuous #6 solid bare conductor shall be installed from the gel cap splice to the ground rod and then to the ground lug on standard.

### 3.2.4. ADDITIONAL CONDUCTOR LENGTHS

1. **Splices and conductors in street light standard.** Splices and fuse holders shall have sufficient slack to separately extend 24" outside of the street light standard hand hole, meaning the fuse holder shall be able to extend 24" outside of the standard hand hole while

the gel cap splice is still stored in the shaft of the standard. Splices and fuse holders shall NOT be spooled in bottom of the street light standard, they shall be stored pointing up into the shaft of the standard.

2. **Splices and conductors in pull box.** Splices shall extend a minimum of four feet above finished grade. Splices shall be elevated off the bottom of pull box.
3. **Feed Point.** Spool up an additional three feet for each circuit feeder conductor into bottom of feed point cabinet.

### 3.2.5. PULL BOX

Install PVC Box. Pull boxes shall be PVC with metal frames and covers, and shall conform to the detail included in the plans. Pull boxes in landscaped areas shall have the top of the box 0" to 1" above final grade and sloped to match the slope of the final grade on all four quadrants. Pull boxes in concrete area shall be set with the top of the box flush with the final grade at all four quadrants.

Install Pull Box. This shall include the cost to supply and install a Polymer Concrete pull box. The minimum size shall be 11" x 18" x 24" deep, with no base. The cover will be 1-3/4" thick, secured with stainless steel bolts, and have a logo of "Street Lights". The base and cover shall be made from a polymer concrete material able to sustain a minimum test load of 12,000#. Color shall be green or gray depending upon location of installation. Carson and Quazite brands are approved for installation. Two feet of crushed rock shall be installed for drainage below the pull box and will extend 6" beyond the outside edge of pull box. The top of box shall be at final grade and sloped to match.

### 3.2.6. FEED POINT

All street light feed points shall be pad mounted. See plans for details of concrete pad, cabinet size and feed point wiring schematic with number of circuits. Padlock shall be obtained from the City of Fargo Engineering Department.

Pedestal type feed point shall be concrete pad mounted (see plans for details of concrete pad, cabinet size and feed point wiring schematic with number of circuits). The pedestal cabinet shall have a NEMA 3R rating. The cabinet shall be constructed of 16 gauge #304 stainless steel, stainless steel hardware and a padlockable stainless steel handle with 3-point latch operation, continuous hinged deadfront, 2" drip shield, gasketed lexan photocell window on side and back of



pedestal cabinet. All circuit breakers shall be rated 22,000 AIC. The pedestal cabinet shall also include a factory installed, interior mounted meter trim which meets the size requirements of the local utility company and a viewport window with gasketed lexan located on the front door of pedestal cabinet. Meter shall be provided by the local utility company.

Feed points shall require two ground rods that are spaced 6' to 7' apart.

All exposed conduit shall be 2" galvanized steel. Concrete pad, riser (if needed) and other miscellaneous items needed to make feed point operational shall be incidental. Verify connection requirements with the local utility company. The Contractor must contact the project Engineer and local utility company to verify specific location and elevation of feed point and the Contractor shall also communicate with the utility company specific connection requirements. The meter shall be furnished and installed by the utility company.

Prefabricated feed point enclosure to be assembled by States Electric, UL 508 listed, service entrance rated, or approved equal.

### **3.2.7. STREET LIGHT STANDARDS**

Refer to Plans for information on size and type of standards. The Contractor shall take delivery of standards from the manufacturer and shall be responsible for the storage and transportation of standards. The packing material shall be removed from standards when stored outside and as per manufacturer's requirements to prevent damage to standards finish. Packing shall also be removed before any standards are delivered to The City of Fargo. The City of Fargo may purchase additional standards for maintenance stock and the Contractor shall be required to deliver and unload standards as directed to the Street Lighting Department located at 4630 15<sup>th</sup> Ave. N.

Any damage to the standards will be the Contractor's responsibility to repair or replace as directed by the Engineer.

### **3.2.8. STREET LIGHT LUMINAIRES**

Refer to Plans for information on type of luminaires. The Contractor shall take delivery of luminaires from the manufacturer and shall be responsible for the storage and transportation of luminaires. The City of Fargo may purchase additional luminaires for maintenance stock and the Contractor shall be required to deliver and unload luminaires as directed to the Street Lighting

Department located at 4630 15<sup>th</sup> Ave. N. All luminaires shall be in their original containers and all luminaires and their containers shall be in new condition.

Any damage to the luminaires will be the Contractor's responsibility to repair or replace as directed by the Engineer.

### **3.2.9. INSTALL STANDARDS AND LUMINAIRES**

Refer to Plans for information on size and type of standards and luminaires. The Contractor shall take delivery of standards and luminaires from the manufacturer or The City of Fargo and shall be responsible for the storage, transportation, installation of standards and luminaires, all wiring within standards and lamps. If the standards and luminaires are supplied by The City of Fargo for installation, the Contractor shall assume the standard one year warranty typically associated with Contractor provided materials.

### **3.2.10. REMOVE LIGHT STANDARD**

The Contractor shall remove standard and luminaire and deliver to the City of Fargo Street Lighting Department located at 4630 15<sup>th</sup> Avenue North or to an alternate site as directed by the City of Fargo. Any standard/luminaire damaged during the removal, storage or transporting shall be replaced at the Contractors expense.

### **3.2.11. REMOVE BASE**

The Contractor shall remove the concrete base as shown on the plans or as directed by the project Engineer. The Contractor shall backfill and properly compact the disturbed area.

### **3.2.12. REMOVE FEED POINT**

The Contractor shall be responsible for removal of feed point, concrete foundation, conduit, conductor, backfilling and compaction in the disturbed area. The removed feed point shall be delivered to The City of Fargo Street Lighting Department located at 4630 15<sup>th</sup> Avenue North.

### **3.2.13. SALVAGE OF MATERIAL**

All existing screw-in-bases, standards, luminaires, feed points, conductor and pull boxes designated for removal shall remain the property of The City of Fargo unless otherwise noted on

the plans or directed by the project Engineer. Salvaged screw-in-bases shall have any dirt or other material removed from inside and outside of the bases tube. If material is deemed unsalvageable, it is the Contractors responsibility to dispose of properly. No materials will be allowed to be buried on project site. It shall be the Contractors responsibility to deliver salvaged materials to The City of Fargo Street Lighting Department located at 4630 15<sup>th</sup> Ave. N., or at an alternate site within the city limits as directed by the project Engineer.

### **3.2.14. STREET LIGHTING INITIAL AND FINAL INSPECTION AND SUBSTANTIAL COMPLETION**

The project will not be classified as substantially complete until the street lighting system is functional, including the completions of all pay items.

After the Contractor has completed the installation of the street lighting system and any clean up items, he shall complete the “Contractor’s Street Lighting Check List”, provided by the City. Each item on the checklist shall be inspected and initialed by the Contractor’s personnel performing this inspection, noting that any deficiencies have been corrected. The Contractor shall forward the completed check list to the project Engineer along with the request for an initial inspection. The Engineer will set a date and time for the inspection. The Contractor shall be present at this inspection and is required to open and close all pull boxes, street light standard hand holes and remove and hold wiring to allow for inspection of splices, fuse holders and anchor bolt nut tightness.

All items requiring additional work after the initial inspection will be noted by the City on the checklist. After the Contractor has completed any deficiencies, the Contractor shall request for final inspection. The project will not be classified as final until the City accepts the project and assigns a final acceptance date. The Contractor is responsible for all maintenance of the street lighting system until the date of final acceptance.

Initial and final inspections will not be performed between November 1<sup>st</sup> and April 1<sup>st</sup>. Inspections will not be done if there is rain or snow or wind greater than 15mph or if the temperature is less than 50° F.

The City of Fargo will perform one final inspection at no cost to the Contractor. Additional initial and final inspections shall assess the Contractor a fee of \$500 for each time an additional initial or final inspection is performed.

**PART 4**  
**GUARANTEE, MEASUREMENT & Payment**

**4.1. GUARANTEE**

The guarantee shall be per the contract.

**4.2. MEASUREMENT AND PAYMENT**

Payment for all items shall be full compensation for all labor, material, equipment and miscellaneous items necessary for constructing these items in place.

**4.2.1 CONCRETE BASE.** The measurement for payment will be for each (EA) size of concrete base installed. Drilling of base hole or hand digging where required, concrete, column forms, anchor bolts, reinforcing rods, conduit, ground rod, and any miscellaneous items necessary for the concrete base will be incidental to the item and will not be measured for payment.

**4.2.2 INNERDUCT/CONDUIT.** Payment will be made for each size of innerduct/conduit and measured by the linear foot (LF). The measurement for payment will be the length of innerduct/conduit installed from center of concrete base to center of concrete base, pull box or feed point. The method used to install innerduct/conduit (such as boring, jacking or trenching) will not be measured but will be incidental to innerduct/conduit. Cost for street light standard conductor, fuse holders and fuses will not be measured for payment and shall be incidental to the price bid to install standards and luminaires. Couplings/fittings used at concrete bases, and the method of innerduct installation, will not be measured for payment but will be included in the price bid for conduit.

**4.2.3 CONDUCTOR.** Payment will be made for each size of conductor and measured by the linear foot (LF). The measurement for payment will be the length of conductor installed from center of concrete base to center of concrete base, pull box or feed point. Additional quantities required as shown in the Materials Section will not be measured for payment but shall be incidental.

**4.2.4 PULL BOX.** The measurement for payment will be for each (EA) type of pull box installed. Pull box, all gel type connectors, backfill and restoration of surrounding area to original conditions will be incidental.

**4.2.5 FEED POINT.** Measurement and payment will be made for each (EA) feed point installed and operational. Cabinet, concrete foundation and pad, conduit, meter trim, riser with weather head (if

needed), ground rods, conductor and conduit between feed point and transformer (for Xcel Energy areas, sized as per Xcel Energy requirements) and other miscellaneous items needed to have a complete and operational feed point shall be incidental to item. Additional conductor lengths at splices and feed points will not be measured for payment but shall be incidental.

- 4.2.6. STREET LIGHT STANDARD.** The measurement for payment will be for each (EA) type of street light standard supplied for installation, or to be supplied to the City of Fargo for maintenance stock. See plans for type of standard required. The cost bid for this item shall include providing unloading, storage and transportation to project site and to The City of Fargo Street Lighting Department.
- 4.2.7. STREET LIGHT LUMINAIRE.** The measurement for payment will be for each (EA) type of street light luminaire supplied for installation, or to be supplied to the City of Fargo for maintenance stock. See plans for type of luminaire required. Cost of lamp shall be incidental to price bid for luminaire. The cost bid for this item shall include providing unloading, storage and transportation to project site and to The City of Fargo Street Lighting Department.
- 4.2.8. INSTALL STANDARD AND LUMINAIRE.** The measurement for payment will be for each (EA) street light standard and luminaire installed as a complete and operational unit. Incidental to this cost shall be all storage, transportation, all wiring and connections within standards, the standard one year warranty typically associated with Contractor provided materials on City of Fargo supplied standards and luminaires. Cost to install standards with twin mast arms and luminaires shall be incidental to the price bid.
- 4.2.9. REMOVE LIGHT STANDARD.** The measurement for payment will be for each (EA) street light standard removed. The removal and transporting of standards and luminaires shall be incidental to the price bid.
- 4.2.10. REMOVE BASE.** The measurement for payment will be for each (EA) concrete base removed. The removal of foundation/base, back filling and compaction, transporting and disposal of base shall be incidental to the price bid. The removal of foundation/base, back filling and compaction, transporting and disposal of bases shall be incidental to the price bid.
- 4.2.11. REMOVE FEED POINT.** The measurement for payment will be for each (EA) feed point removed. The removal, backfilling and compaction, transportation and disposal of feed point and foundation shall be incidental to the price bid. The removal, backfilling and compaction, transportation and disposal of feed point and foundation shall be incidental to the price bid.

**4.2.12. REMOVAL AND/OR SALVAGE OF MATERIALS.** Unless specifically called out as a bid item, all costs associated with the removal or salvage of materials, including proper disposal of removed materials and/or delivery of salvaged materials, shall be incidental to the project.

Where a bid item exists for removal and the item is deemed to be salvaged per Section 3 “SALVAGE OF MATERIAL” above, the contract unit price for the removal item shall include all costs to salvage and deliver the material as specified.

**4.2.13. BORROWING OF MAINTENANCE STOCK.** All costs for the Contractor to borrow City maintenance stock, including all costs for work to load, transport, and unload borrowed and returned materials, shall be considered incidental to the project.

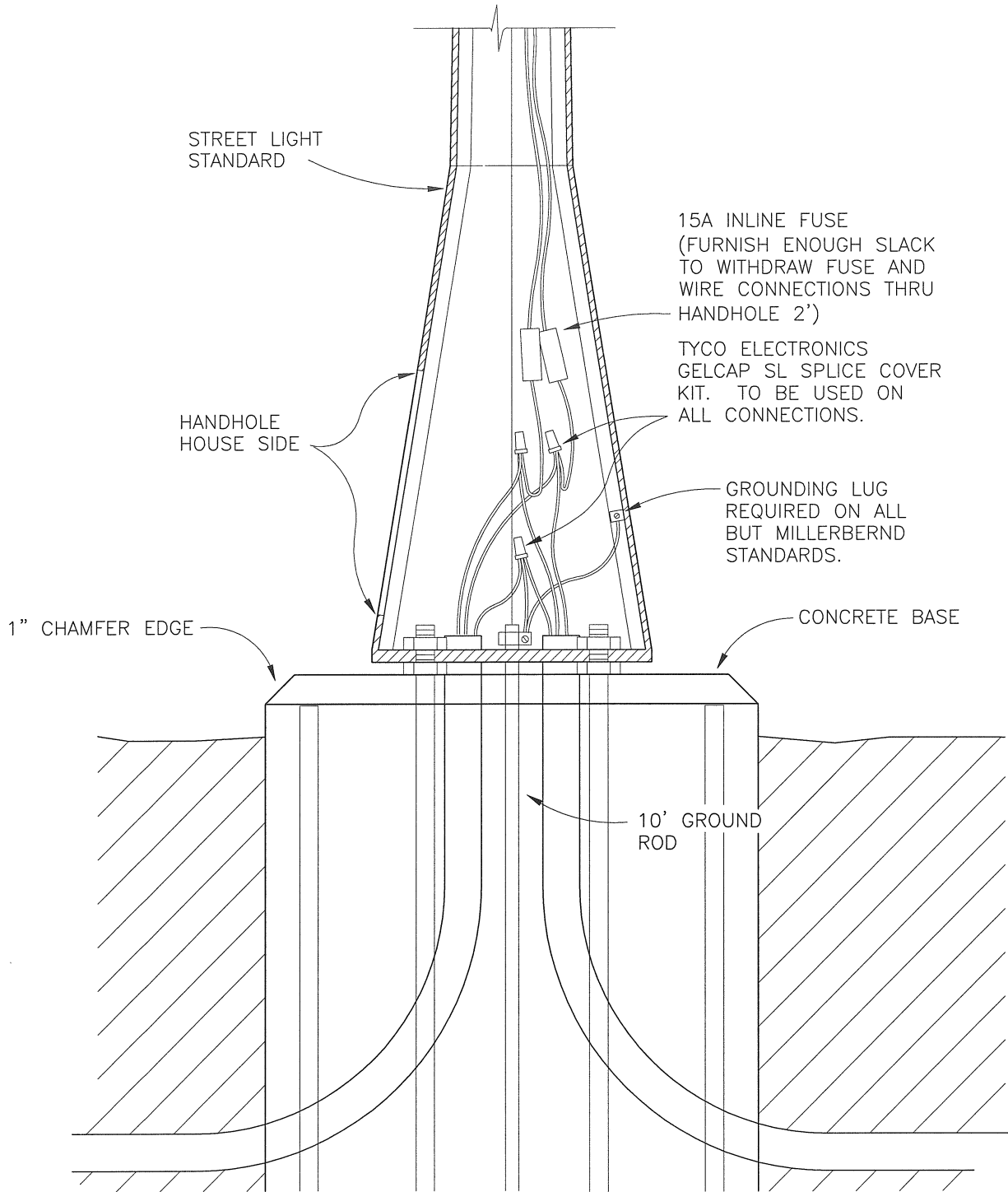

NOTE:  
 1. ALL CONDUIT LOCATED IN STREET LIGHT BASES, FEED POINT FOUNDATIONS AND PULL BOXES SHALL HAVE BELL ENDS.

SECTION NO. 4400	DRAWING NO. 5.1
REV.D.	
<b>STANDARD STREET LIGHT FOUNDATION</b>	
CITY OF FARGO ENGINEERING DEPARTMENT	
APPROVED <b>BED</b>	DATE <b>2-21-2012</b>

PEDESTAL TYPE FEED POINT ASSEMBLED BY STATES ELECTRIC: PEDESTAL SHALL BE NEMA 3R RATED ENCLOSURE, CONSTRUCTED OF 16 GAUGE #304 STAINLESS STEEL, CONTINUOUS HINGED DEAD FRONT DOOR, PADLOCKABLE THREE POINT STAINLESS STEEL HANDLE, 2" DRIP SHIELD, GASKETED LEXAN METER SOCKET VIEW PORT WINDOW LOCATED ON FRONT AND PHOTOCELL WINDOW LOCATED ON SIDE AND BACK OF PEDESTAL CABINET.

SINGLE CIRCUIT FEED POINT SHALL BE:  
14" WIDE x 48" HIGH x 10" DEEP.

MULTI CIRCUIT FEED POINT SHALL BE:  
15" WIDE x 48" HIGH x 12" DEEP.

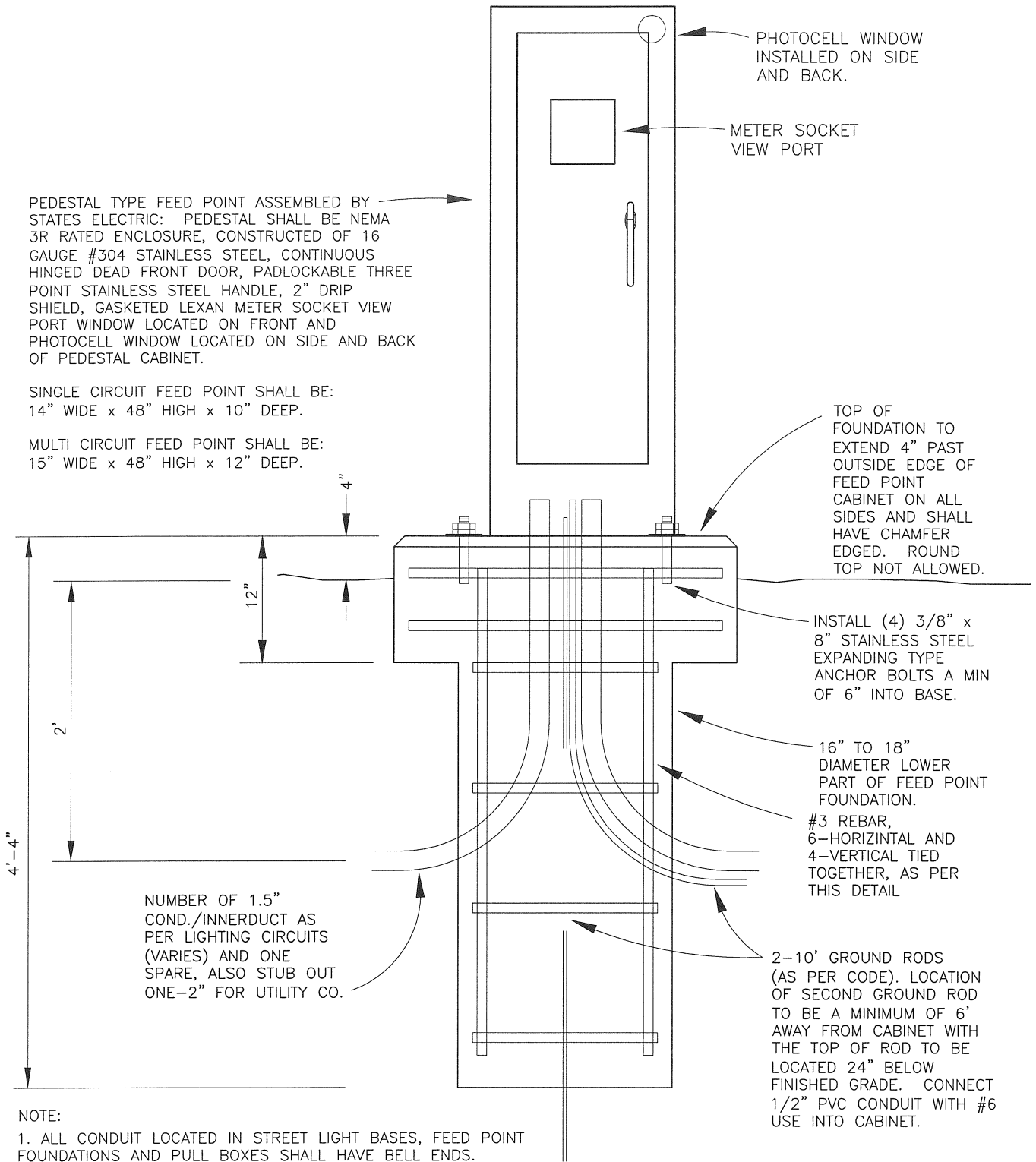

PHOTOCELL WINDOW  
INSTALLED ON SIDE  
AND BACK.

METER SOCKET  
VIEW PORT

TOP OF  
FOUNDATION TO  
EXTEND 4" PAST  
OUTSIDE EDGE OF  
FEED POINT  
CABINET ON ALL  
SIDES AND SHALL  
HAVE CHAMFER  
EDGED. ROUND  
TOP NOT ALLOWED.

INSTALL (4) 3/8" x  
8" STAINLESS STEEL  
EXPANDING TYPE  
ANCHOR BOLTS A MIN  
OF 6" INTO BASE.

16" TO 18"  
DIAMETER LOWER  
PART OF FEED POINT  
FOUNDATION.

#3 REBAR,  
6-HORIZONTAL AND  
4-VERTICAL TIED  
TOGETHER, AS PER  
THIS DETAIL

2-10' GROUND RODS  
(AS PER CODE). LOCATION  
OF SECOND GROUND ROD  
TO BE A MINIMUM OF 6'  
AWAY FROM CABINET WITH  
THE TOP OF ROD TO BE  
LOCATED 24" BELOW  
FINISHED GRADE. CONNECT  
1/2" PVC CONDUIT WITH #6  
USE INTO CABINET.

NUMBER OF 1.5"  
COND./INNERDUCT AS  
PER LIGHTING CIRCUITS  
(VARIES) AND ONE  
SPARE, ALSO STUB OUT  
ONE-2" FOR UTILITY CO.

NOTE:

1. ALL CONDUIT LOCATED IN STREET LIGHT BASES, FEED POINT FOUNDATIONS AND PULL BOXES SHALL HAVE BELL ENDS.

SECTION NO. 4400	DRAWING NO. 5.2
------------------	-----------------

REV.D.

**STREET LIGHT FEED  
POINT CROSS-SECTION**

CITY OF FARGO  
ENGINEERING DEPARTMENT

APPROVED *BED*

DATE *2-21-2012*



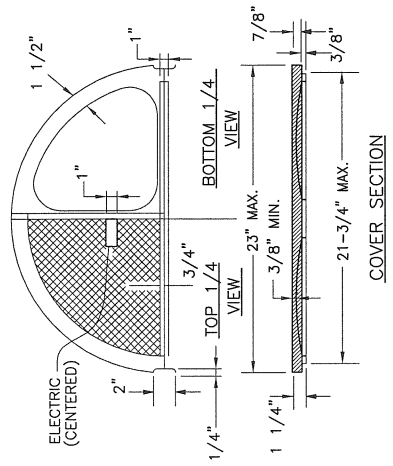
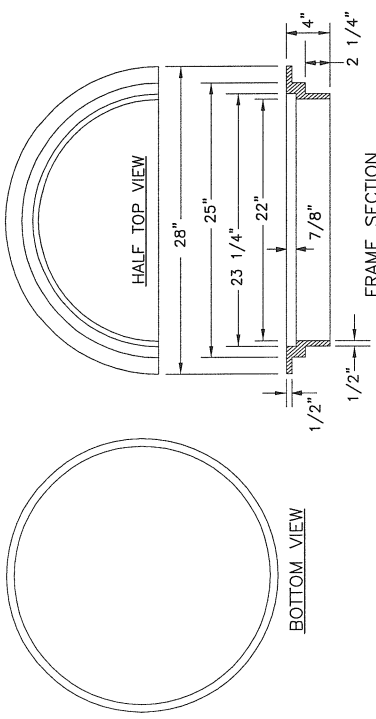

FRAME AND COVER CASTING  
 NOTE:  
 ALL CASTINGS ARE GRAY IRON AS PER  
 SPEC. 3321 CLASS 35B

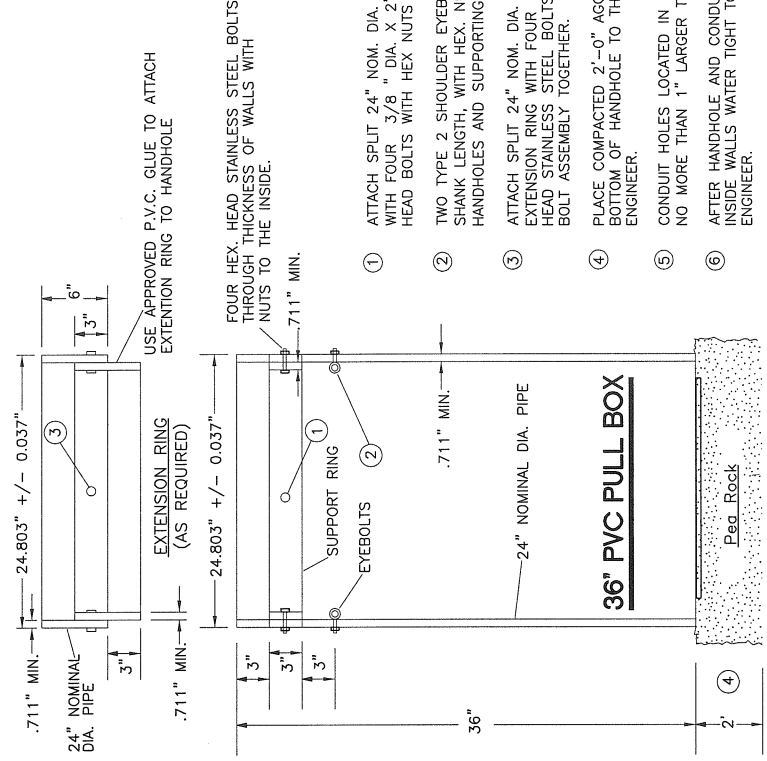

- ① ATTACH SPLIT 24" NOM. DIA. P.V.C. COVER SUPPORT RING WITH FOUR 3/8" DIA. X 2" LONG STAINLESS STEEL HEX HEAD BOLTS WITH HEX NUTS AT 90° APART.
- ② TWO TYPE 2 SHOULDER EYEBOLTS, 3/8" DIA. X 1 1/4" SHANK LENGTH, WITH HEX. NUTS AT 180° APART (FOR LIFTING HANDHOLES AND SUPPORTING ELECTRICAL CABLES)
- ③ ATTACH SPLIT 24" NOM. DIA. P.V.C. COVER SUPPORT EXTENSION RING WITH FOUR 3/8" DIA. X 2" LONG HEX. HEAD STAINLESS STEEL BOLTS WITH HEX. NUTS AT 90° APART. BOLT ASSEMBLY TOGETHER.
- ④ PLACE COMPACTED 2'-0" AGGREGATE DRAIN BED BELOW BOTTOM OF HANDHOLE TO THE SATISFACTION OF THE ENGINEER.
- ⑤ CONDUIT HOLES LOCATED IN THE BARREL SECTION ARE SIZED NO MORE THAN 1" LARGER THAN THE CONDUIT USED.
- ⑥ AFTER HANDHOLE AND CONDUIT INSTALLATION, SEAL ALL INSIDE WALLS WATER TIGHT TO THE SATISFACTION OF THE ENGINEER.
- ⑦ THE P.V.C. PIPE COMPLIES WITH ASTM F679T-1.
- ⑧ HEX. HEAD BOLTS AND NUTS ARE TO BE STAINLESS STEEL. OTHER FASTENERS TO BE GALVANIZED AS PER AASHTO M-232
- ⑨ PROVIDE ENOUGH SLACK TO PULL CONDUCTOR AND SPLICES A MINIMUM OF 4' ABOVE FINISHED ELEVATION.

SECTION NO. 4400	DRAWING NO. 5.3
REV.D.	
<b>STREET LIGHT PULL BOX, FRAME, AND COVER</b>	
CITY OF FARGO ENGINEERING DEPARTMENT	
APPROVED <i>BEID</i>	DATE <i>2-21-2012</i>

**CITY OF FARGO SPECIFICATIONS  
LANDSCAPING**

**PART 1  
DESCRIPTION OF WORK**

The work to be done under this section of the Specifications and the accompanying plans consists of furnishing and installing nursery-grown trees, shrubs, perennials, edging, benches, concrete paving, and other related material in the City of Fargo.

Certified Arborist Required:

Trees must be planted by a firm having an International Society of Arboriculture Certified Arborist on staff (not contracted nor consultant). A copy of the current and valid certificate shall be submitted to the Engineer prior to tree planting work (in the case of subcontracted tree planting work, attach the certificate to the Sublet Request Form G6 for the tree planting subcontractor).

**PART 2**  
**MATERIAL**

All materials shall be obtained from sources approved by City Forestry or Project Manager. The plant material used in connection with this work shall conform to the latest edition of the “American Standard for Nursery Stock”, sponsored by American Association of Nurserymen, Inc.

2.1. PLANT MATERIALS

*2.1.1. GENERAL*

All plant material shall comply with all applicable State and Federal laws, including inspection certificates, which shall include the project number and plant material that the certification covers. All plant material is subject to inspection by representatives of the State and Federal Government.

All plant materials and specified shall conform to the sizing and grading standards as developed by the American Association of Nurseryman.

All plant material furnished shall be true to name and type and legible labels shall be furnished to insure that all species, varieties, boxes, bundles, bales or other containers are identified. The information on the label shall cover the botanical genus, species, common name and size of each species.

All plant material shall be sound, healthy specimens and first class representatives of their species or variety, and shall have well-formed tops and healthy root systems.

All container-grown, and balled and burlapped (B&B) plant material is subject to internal examination of the ball at any time to ascertain the condition of the roots and the ball.

All plants shall be nursery grown and shall be root-pruned, maintained and/or cultivated for a minimum of two (2) years prior to the contract date in similar climatic conditions as the project location.

If a Contractor is unable to locate sufficient plant material in specified sizes, negotiation for unit price reduction shall be concluded prior to planting.

All plant materials shall be “Nursery Grown” unless otherwise specified.

No substitutions of specified sizes, grades, species, qualities or forms shall be made without written permission of the City Forester or Project Manager.

### *2.1.2. REJECTION*

Plant materials which lack proper proportions, have serious injuries to the bark or roots, broken branches, objectionable disfigurements, shriveled dry roots, broken balls, insect pests, diseases, or which are not found to comply with the Specifications in any way will be rejected. Rejected plant material shall be removed from the project as soon as practical.

Plant materials, which are planted and later discovered to be not true to name, may be allowed to remain in place without payment being made.

Any plant material, which does not meet the specified minimum size, shall be rejected.

Fresh dug material is given preference over plant material held in storage. Plant material held in storage shall be rejected if excessive growth has occurred.

Unnecessary injury to or removal of fibrous roots from the plant material is cause for rejection of the plant material. The soil for balled, container-grown, or pot-grown material shall be in such condition so as to insure no crumbling or cracking. Balls shall be wrapped with burlap prior to removal from the ground. The burlap shall be held in place with cork or pinning nails. Handling of balled and burlapped material shall be in such a manner as to keep the earth intact. Plant material on which earthen balls do not hold together or which crack in handling shall be rejected.

Containerized plants shall have been growing in a container for a minimum of two seasons and have a healthy, vigorous root system. Root balls that crumble when removed from the container will be rejected.

### 2.2. MULCH

City of Fargo mulch shall be used and is available at the compost site at no cost to the Contractor. Contractor to load and haul. If applicable, in all common planting beds the existing lawn is to be 'weed-killed' with a chemical herbicide suitable for use for killing lawn, prior to the placement of mulch. The cost for this item shall be included in the contract price per planting.

### 2.3. STAKES

Stakes shall be steel and will be notched or drilled to retain guy wires. Steel post will be placed outside of the planting pit. The Contractor shall be responsible for the removal of the stakes after the plant material has adjusted to its site conditions (typically 2 full growing seasons). Contact the City Forester in advance for approval. The cost for this item shall be included in the contract price per tree.

### 2.4. WIRE

The minimum size of wire used for guying shall be 12 gauge. Substitution requests for standard hose and wire guying will not be approved. Wire should be level from stake to tree tie. The cost for this item shall be included in the contract price per tree.

### 2.5. TREE TIES

Trees will be anchored to stakes by a 16" long polypropylene 1 1/2" strap. The cost for this item shall be included in the contract price per tree.

### 2.6. BACKFILL FOR PLANT MATERIAL

The backfill shall be a suitable loam/clay mixture. When possible, use existing soil as backfill. In heavy clay soils amendments may need to be added to improve soil structure. Mix amendments prior to filling the hole to prevent stratification. The cost for this item shall be included in the contract price per tree.

### 2.7. LANDSCAPING EDGING

Edging shall be 'bullet' style commercial grade precast concrete edging where shown on plans and as indicated on details. Concrete shall be 3,500 minimum PSI, natural gray (without integral color). Contractor installing edging must have a minimum of 3 years experience installing 'bullet' style concrete edging and shall provide documentation of such experience.

### 2.8. BIO-BARRIER LANDSCAPE WEED BARRIER

Weed barrier shall be Bio-Barrier II weed barrier or approved equal. Place in perennial, shrub, and ornamental grass planting areas as indicated on plans.

2.9. BENCH

6' metal bench to be Wausau Tile model #MF 2200, or Sitiescapes, Inc. model #CV1-1000PF, or Dumor Model #93, or approved equal. Bench to be powder coated by manufacturer. Color to be black. Bench to be surface mounted to concrete pad with manufacturer's recommended surface mounting hardware.

2.10. CONCRETE PAD FOR BENCH

Concrete pad to be 4" thick, natural colored concrete, 4,000 minimum PSI. Pad to have #4 rebar 24" O.C. centered in slab, each way. Pad finish to be medium broom. Install pad over 2" thick, class 5 crushed aggregate base, over compacted subgrade. Dowel into adjacent bike path as indicated in detail. Refer to plans and details for additional information. The cost for the concrete pad shall be included in the contract price per bench.

2.11. ROCK MULCH

2" to 4" diameter, washed granite rock mulch. Install to a depth of 3" over a 5 oz. woven weed barrier fabric. In all areas where rock mulch and weed barrier fabric is used, the existing lawn that is stripped and removed shall become property of the Contractor. The planting bed shall be thoroughly tilled and fine graded. Utilize rock mulch where specifically called out on plans. The 5 oz. woven weed barrier fabric shall be included in the contract price for rock mulch.

2.12. IMPORT FILL

All clay fill required to be imported shall meet the requirements set forth for IMPERVIOUS FILL specified in Section 2000 of these Specifications

2.13. TOPSOIL

All topsoil required to be imported shall meet the requirements set forth for TOPSOIL – IMPORT SPECIAL specified in Section 2000 of these Specifications.

**PART 3**  
**CONSTRUCTION**

3.1. GENERAL

The Contractor shall furnish all necessary machinery, tools, labor and materials required and shall fully complete the work in accordance with the contract.

Contractor shall provide all necessary means and measures to protect storm drain inlets from erosion caused by their activities.

The entire work to be performed under the agreement is to be at the Contractor's risk, and the Contractor is to assume responsibility for all damages to the work or to contiguous property.

The Contractor shall have charge of and be responsible for the entire project until its completion and acceptance. It shall be the Contractor's responsibility to maintain all stages of work in a safe and suitable condition at all times including nights, weekends and holidays.

The Contractor shall make observations of their work during such periods as are necessary to ensure proper performance thereof.

The Contractor shall designate one person who shall have charge of the job and to whom the City Forester or Project Manager shall give directions and communicate with.

The Contractor shall be insured against liability for injury to employees in accordance with the laws of the State of North Dakota pertaining thereto.

Precautions shall be exercised at all times for the protection of persons (including employees) and property. The safety provision of applicable laws shall be observed.

The project is to be completed under the direction of the City Forester, Project Manager or designated representative, and all material used and the method of performing the work shall, at all times, be subject to review. This individual shall have the authority to decide questions, which arise as to quality and acceptability of material furnished and work performed.

3.2. GENERAL PREPARATION

Planting holes must be prepared by Gramegna spading machine, or approved equal tilling method, at specified locations to a depth of approximately 8 inches. Walls of the planting hole shall be roughed up to remove the glazing affects of the tilling. The bottom of the hole shall be rough, flat

and deep enough so that the flare roots are even with the existing ground line or slightly higher. Some hand digging in the center of the hole may be necessary to achieve proper depth.

For individual tree planting locations, a single, 3-4" diameter vertical hole shall be drilled in the bottom or lower side of the planting hole. It shall be a minimum of 3 feet in depth and backfilled with loose soil prior to tree installation.

### 3.3. B&B AND CONTAINERIZED MATERIAL

The hole shall be partially backfilled and firmed. The bottom ring of wire is to be removed; tree placed in the hole, then the remainder of the wire basket is to be cut away and removed. The ball shall be set carefully into the hole & plumbed. The burlap shall be pulled back two-thirds the depth of the root ball and removed. Rope and twine should also be cut from the trunk. Then the backfilling process shall be completed. Balled and burlapped material which is dropped into the planting holes so as to cause the ball to crack and pull away from the roots shall be rejected. All containers including biodegradable or decomposable pots must be removed. If roots are growing in a spiral around the soil ball, the roots need to be severed. Using a sharp knife, make a crisscross cut across the bottom of the ball and vertical cuts on the sides of the ball deep enough to cut the net of roots.

When completed, planting site shall have convex shape, stopping water from pooling around the tree trunk.

### 3.4. BARE ROOT PLANT MATERIAL

All bare root plant installation work shall be completed before May 15. Bare root planting stock has had the soil removed from the root system. The root system must be kept cool and moist at all times up until the moment of planting. Watering shall occur immediately after installation. Refer to standard bare root tree planting details for additional information.

### 3.5. TREE SPADED MATERIAL

A minimum 44 inch diameter tree spade shall be used. The flare root must be at ground line or slightly above. The sides of the planting hole shall be sufficiently roughed up by hand to eliminate the glazing effect of the spade. It is critical that the tree be set at proper grade to avoid settling with subsequent watering. Plants with crumbling root balls or loss of soil during transport will be rejected.

Any air pockets due to movement or settling must be filled with topsoil.



### 3.6. LOCATION AND PROTECTION OF EXISTING UTILITIES

The location of the public or private utilities may be shown on the plans, as reported by the various utility companies and the City, but this does not relieve the Contractor of the responsibility of determining the accuracy or completeness of said locations. North Dakota law requires the Contractor to contact ND One-Call at 800-795-0555 prior to any underground interference. The Contractor shall protect all trees, shrubs, manholes, water shut-off, survey monuments, or any other existing utilities from damage. Any utilities that are damaged during the course of the work shall be repaired or replaced to the satisfaction of the Engineer at the Contractor's expense.

### 3.7. STAKING OF PLANT MATERIAL

When the first watering of the plant material is complete, all trees shall be staked and guyed as shown in the detail. The stakes shall be driven so they support the trees and are firm. Guys shall be sufficiently tight and horizontal to transfer support from stake to tree.

### 3.8. MULCHING OF PLANT MATERIAL

Place wood chips loosely around boulevard trees within 24 hours after planting to uniform depth of three (3) inches and a minimum diameter of six (6) feet. All planting beds will be fully mulched. 'Round-up' or approved equal shall be applied according to manufacturer's recommendations prior to plant and mulch installation. These costs shall be included in the contract price per tree.

### 3.9. LAYOUT AND STAKING

The Contractor shall be responsible for staking the locations for individual plantings and bed alignments, and shall contact the Project Manager or City Forester prior to staking. All stakes shall be labeled as to identify proper specie at planting site.

The City Forester or Project Manager must approve changes in field locations or procedures.

### 3.10. PLANTING PROCEDURES

The tree-planting Contractor shall maintain a communication with the City Forester or Project Manager and verify when:

- a) Planting stock has been ordered.
- b) Planting stock has been received.
- c) All other material required for the planting are on hand.

Contractor is to demonstrate to City Forester, per Specifications, how each tree and/or shrub will be planted. This is mandatory before any planting is to begin. Contractor shall make available the crew foreman, project representative, or any other Contractor staff that will be involved with the planting process.

The planting pit shall be excavated to the following dimensions:

Trees	72" x 72" x depth to flare root
Shrubs/Perennials	24" x 24" x depth to flare root

Each plant pit shall be backfilled with the approved planting soil placed in layers around the roots. Each layer shall be tamped carefully in a manner to avoid injury to the roots or disturbing the position of the tree. When approximately 2/3 to 3/4 of the planting pit has been backfilled, the hole shall be watered so as to settle the soil in and around all of the roots. After the water has been absorbed, the planting pit shall be filled with the planting soil, tampered lightly to grade and watered thoroughly again. Any further settlement now, or during the maintenance/establishment period, shall be brought to grade with additional planting soil.

Trees shall be staked immediately upon being planted and the staking shall be considered and organized as part of the planting process. Stakes shall be snug after settling has taken place. No part of any wire shall be in contact with any part of each tree. All excess wire shall be removed or wrapped in such a way as to eliminate any loose ends. Wire shall be level.

**PART 4**  
**GUARANTEE, MEASUREMENT & PAYMENT**

4.1. GUARANTEE

The guarantee shall be per the contract, and shall extend beyond the date of Final Completion, which is defined as the date of completion of the Establishment Period. During the warranty period, the Contractor shall replace all unacceptable plant material in the spring planting season or as directed by the City Forester or Project Manager. Replacement trees shall be guaranteed for 1 year.

4.2. ESTABLISHMENT PERIOD

The Establishment Period shall extend 1-year from the date of Substantial Completion, which is the date all other contract items are completed and accepted by the City. During the Establishment Period, the Contractor shall properly maintain all plantings included in the work. The maintenance procedures shall include: protective measures against pests and diseases (including rabbit and/or other rodent protection); watering as often as required by necessity or direction of the City Forester/Project Manager or both; repairing damage to the watering basins; and other maintenance procedures as deemed necessary by the City Forester or Project Manager including the removal of any dead plant material from the project. A DETAILED INSPECTION FORM INCLUDING WORK PERFORMED WILL NEED TO BE INCLUDED WITH ALL BILLING STATEMENTS. If these duties are not satisfactorily performed, the City Forester or Project Manager will find means for the work to be completed and the cost deducted from the retainage.

Watering trees and related plant material must be completed in a timely fashion. Trees and shrubs must not be allowed to become stressed due to water deficit.

All plant material shall be watered each week unless soil moisture is adequate or excessive.

It is the Contractor's responsibility to determine when to apply water and when to refrain from applying water. Watering frequency is dependent upon weather and soil conditions.

When watering plants, application rate and pressure must be sufficient to allow water to soak into the soil to the full root depth without washing away any mulch, plants, seed or soil.

- 4.2.1. The City Forester or Project Manager will make an inspection of the plant material and establishment procedures. Establishment procedures that have not been performed shall be brought to the Contractor’s attention and may cause the establishment period to be extended.
- 4.2.2. Upon completion of the establishment period the City Forester or Project Manager will make an inspection of the plant material for acceptability. The inspection will normally be made during the week that the establishment period terminates.
- 4.2.3. Any plant material that is 25% dead or more shall be considered dead and must be replaced by the Contractor. Trees shall be considered dead when the main leader has died back, or 25% of the crown is dead. Shrubs shall be considered dead when 25% of the branching is dead. Removal of dead plant material shall occur right away with replacement taking place immediately or as soon as possible during the next planting season.

4.3. INSPECTION AND ACCEPTANCE

The tree-planting Contractor shall be responsible for all inspections and approval of plant materials that may be required by state, federal and/or other authorities and shall secure permits and certificates as may be required.

Each item furnished shall be within specified size, grade, species, height, form, spread, uniformity, health, condition, and free from damage, dehydration, and disease. The rejection of plant materials may take place at any time during the execution of the contract. The rejected plants or materials shall be removed immediately from the project site. All replacements of rejected plants and materials shall be subject to approval by the City Forester or Project Manager prior to use on the project.

4.4. COMMENCEMENT AND COMPLETION OF WORK

The Contractor shall secure plant materials upon receiving the notice to proceed to guarantee specified species and sizes. Planting operations shall be conducted under favorable weather conditions during the planting seasons herein defined:

- Spring ..... May 1 to June 15
- Fall ..... September 1 to October 15

All plant installation work shall be completed by the last day of the season.

All plantings shall be maintained, watered and be in a healthy condition for the duration of the Establishment Period as defined above.

#### 4.5. MEASUREMENT AND PAYMENT

Payment will not be made for work covered under this Section of the Specifications, whether performed by the Contractor or a subcontractor, unless the certification requirements described in PART 1 of this Section of the Specifications are met.

Payment for each contract item shall be full compensation for furnishing and applying water, and for all materials, equipment, tools, labor, and incidentals necessary to complete the work as specified herein.

Payment shall be made on the following basis:

- 1) At the discretion of the City Forester or Project Manager, contract items will be paid less 5% retainage as they are completed during the project.
- 2) Upon Substantial Completion, all contract items will be paid less 5% retainage except "Establishment Period" which will not yet be paid.
- 3) Final payment will be made upon Final Completion, defined as the completion of the Establishment Period, which will include payment for all contract items and release all retainage.
- 4) Contractor is responsible for notifying City Forester and/or Project Manager prior to scheduled watering. A detailed inspection form including work performed and watering dates shall be included with all billing statements. If these duties are not satisfactorily performed, the City Forester or Project Manager will find means for the work to be completed and the cost deducted from the retainage.

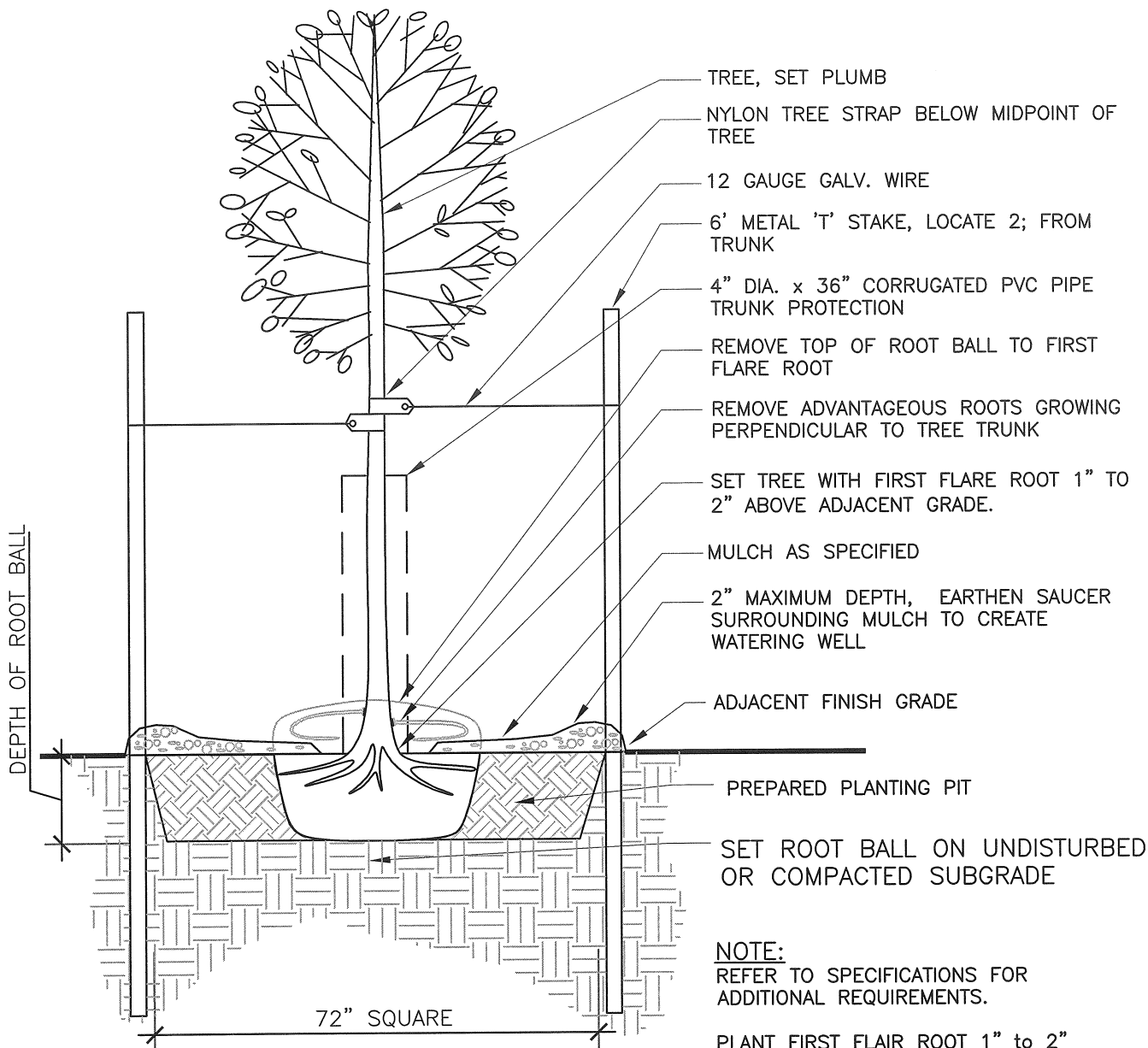

- TREE, SET PLUMB
- NYLON TREE STRAP BELOW MIDPOINT OF TREE
- 12 GAUGE GALV. WIRE
- 6' METAL 'T' STAKE, LOCATE 2; FROM TRUNK
- 4" DIA. x 36" CORRUGATED PVC PIPE TRUNK PROTECTION
- REMOVE TOP OF ROOT BALL TO FIRST FLARE ROOT
- REMOVE ADVANTAGEOUS ROOTS GROWING PERPENDICULAR TO TREE TRUNK
- SET TREE WITH FIRST FLARE ROOT 1" TO 2" ABOVE ADJACENT GRADE.
- MULCH AS SPECIFIED
- 2" MAXIMUM DEPTH, EARTHEN SAUCER SURROUNDING MULCH TO CREATE WATERING WELL
- ADJACENT FINISH GRADE
- PREPARED PLANTING PIT
- SET ROOT BALL ON UNDISTURBED OR COMPACTED SUBGRADE

DEPTH OF ROOT BALL

72" SQUARE

**NOTE:**  
REFER TO SPECIFICATIONS FOR ADDITIONAL REQUIREMENTS.

PLANT FIRST FLAIR ROOT 1" to 2" ABOVE SURROUNDING GRADE.

TREES LOCATED IN LAWN TO HAVE 4" DEPTH BY 6' DIAMETER WOOD MULCH, UNLESS OTHERWISE NOTED.

KEEP MULCH 6" AWAY FROM TRUNK.

REFER TO 'TREE ROOT BALL PREPARATION' FOR ADDITIONAL INFORMATION.

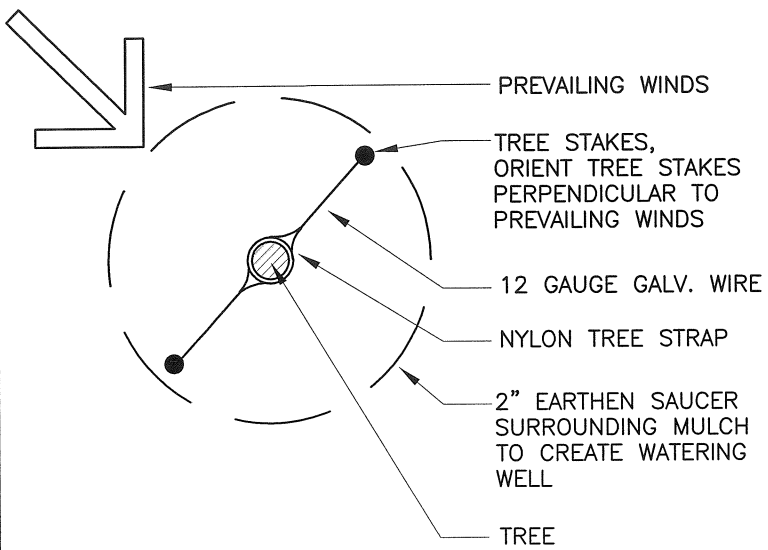

SECTION NO. 7000	DRAWING NO. 5.1
REV,D.	
<b>TREE PLANTING DETAIL</b>	
CITY OF FARGO ENGINEERING DEPARTMENT	
APPROVED <i>BEO</i>	DATE <i>2-21-2012</i>

DO NOT ALLOW ROOTS TO DRY-OUT!!!:

DO NOT BRING TREES TO SITE UNLESS TREES WILL BE PLANTED IMMEDIATELY.

KEEP PLANTS MOIST AND COOL UNTIL READY FOR PLANTING.

KEEP TREES OUT OF DIRECT SUNLIGHT UNTIL PLANTED.

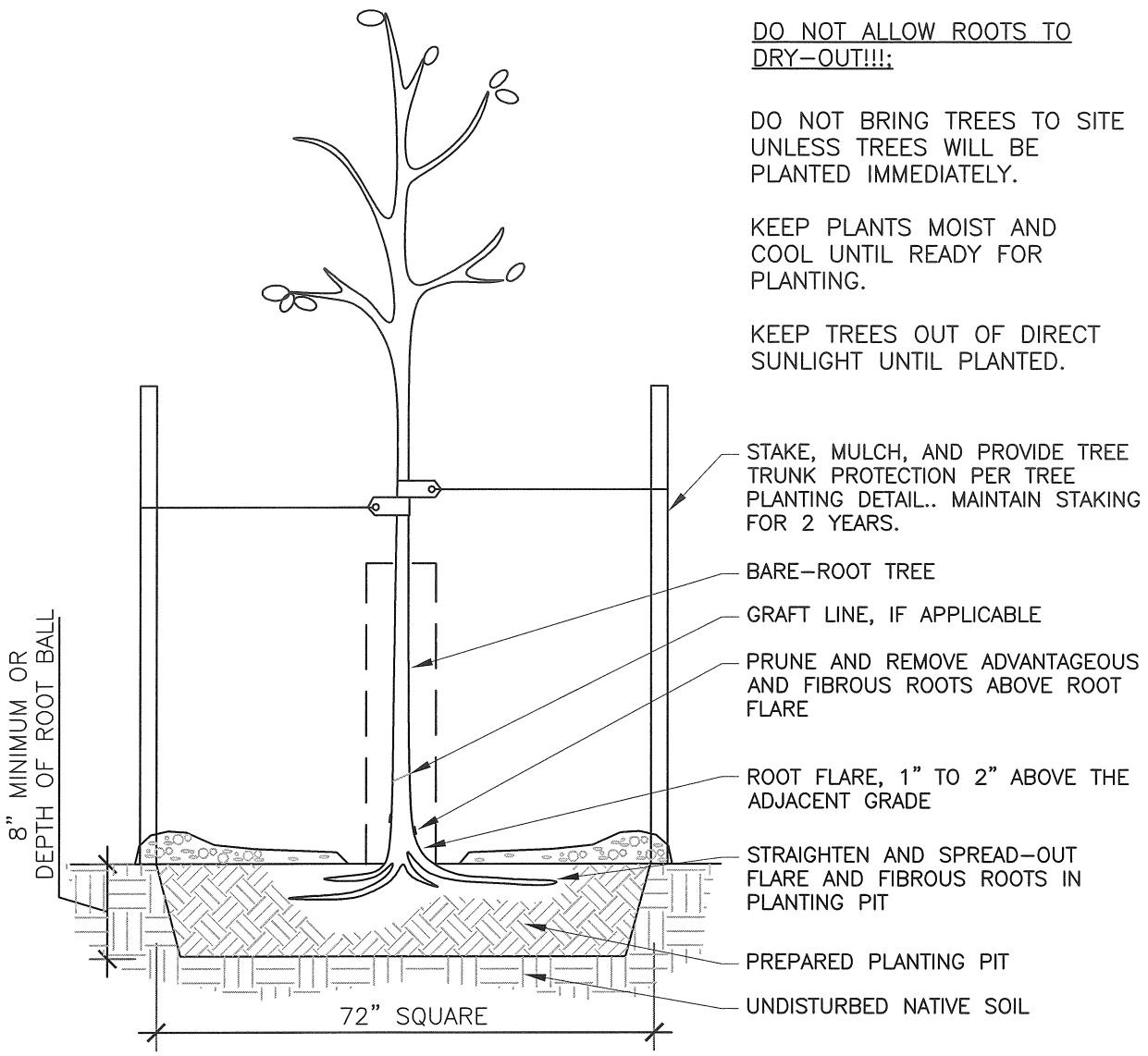

BARE-ROOT PREPARATION AND PLANTING  
NOT TO SCALE

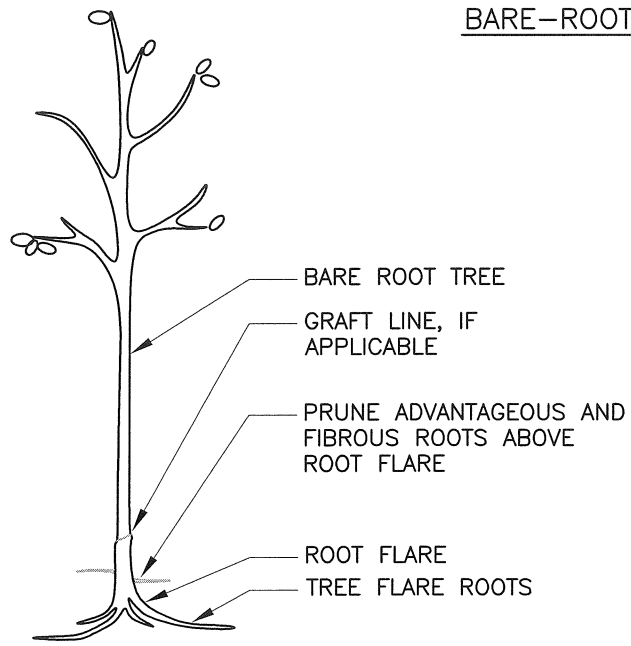

TYPICAL BARE-ROOT  
NOT TO SCALE

SECTION NO. 7000	DRAWING NO. 5.2
REV,D.	
<i>BARE ROOT TREE PLANTING DETAIL</i>	
CITY OF FARGO ENGINEERING DEPARTMENT	
APPROVED <i>RED</i>	DATE <i>2-21-2012</i>

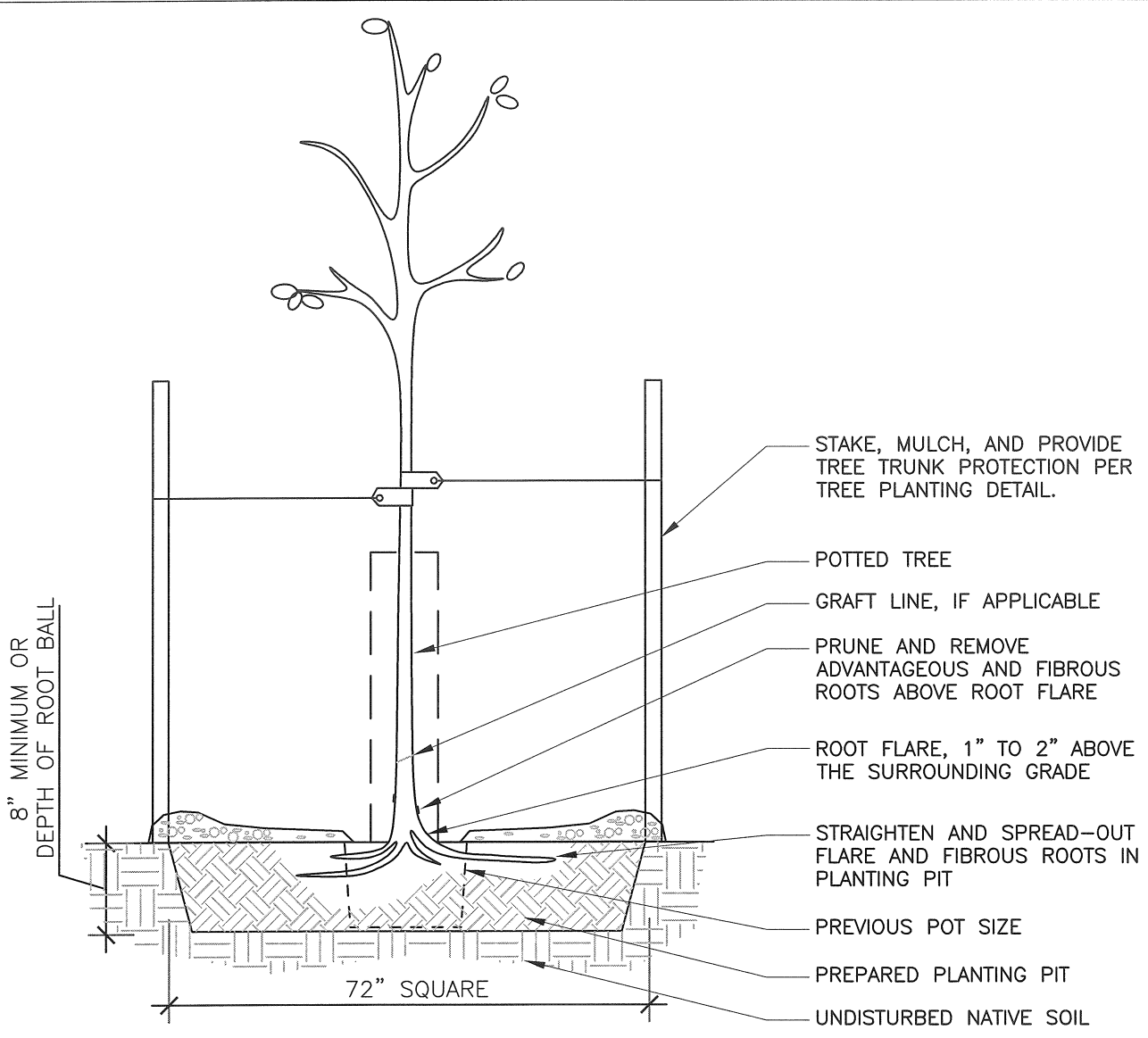

POTTED TREE ROOT BALL PREPARATION AND PLANTING  
NOT TO SCALE

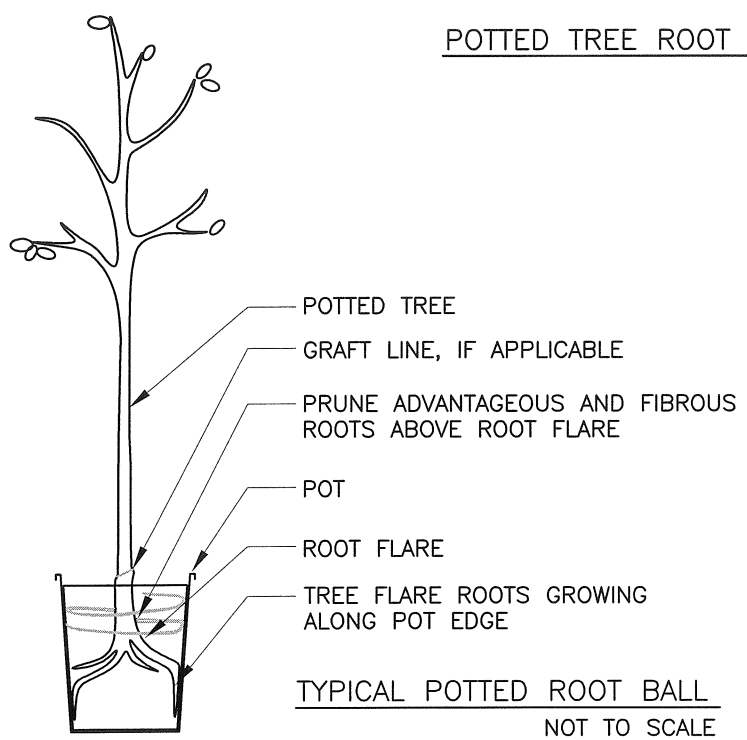

SECTION NO. 7000	DRAWING NO. 5.3
REV,D.	
<i>POTTED TREE ROOT BALL PLANTING DETAIL</i>	
CITY OF FARGO ENGINEERING DEPARTMENT	
APPROVED <i>BED</i>	DATE <i>2-21-2012</i>



REMOVE WIRE BASKET AND BURLAP;

REMOVE TOP OF ROOT BALL, ADVANTAGEOUS ROOTS AND FIBROUS ROOTS LOCATED ABOVE FLARE ROOTS TO DETERMINE PROPER PLANTING DEPTH.

REMOVE WIRE BASKET AND BURLAP FROM BOTTOM OF ROOT BALL BEFORE PLACING ROOT BALL IN HOLE.

ALL TWINE, ROPE, WIRE BASKET AND BURLAP TO BE REMOVED.

AFTER PLACING ROOT BALL IN HOLE, ADJUST PLANTING DEPTH AS NECESSARY TO PLACE ROOT FLARE AT OR SLIGHTLY ABOVE ADJACENT GRADE.

REMOVE REMAINDER OF WIRE BASKET AND BURLAP PRIOR TO BACKFILLING.

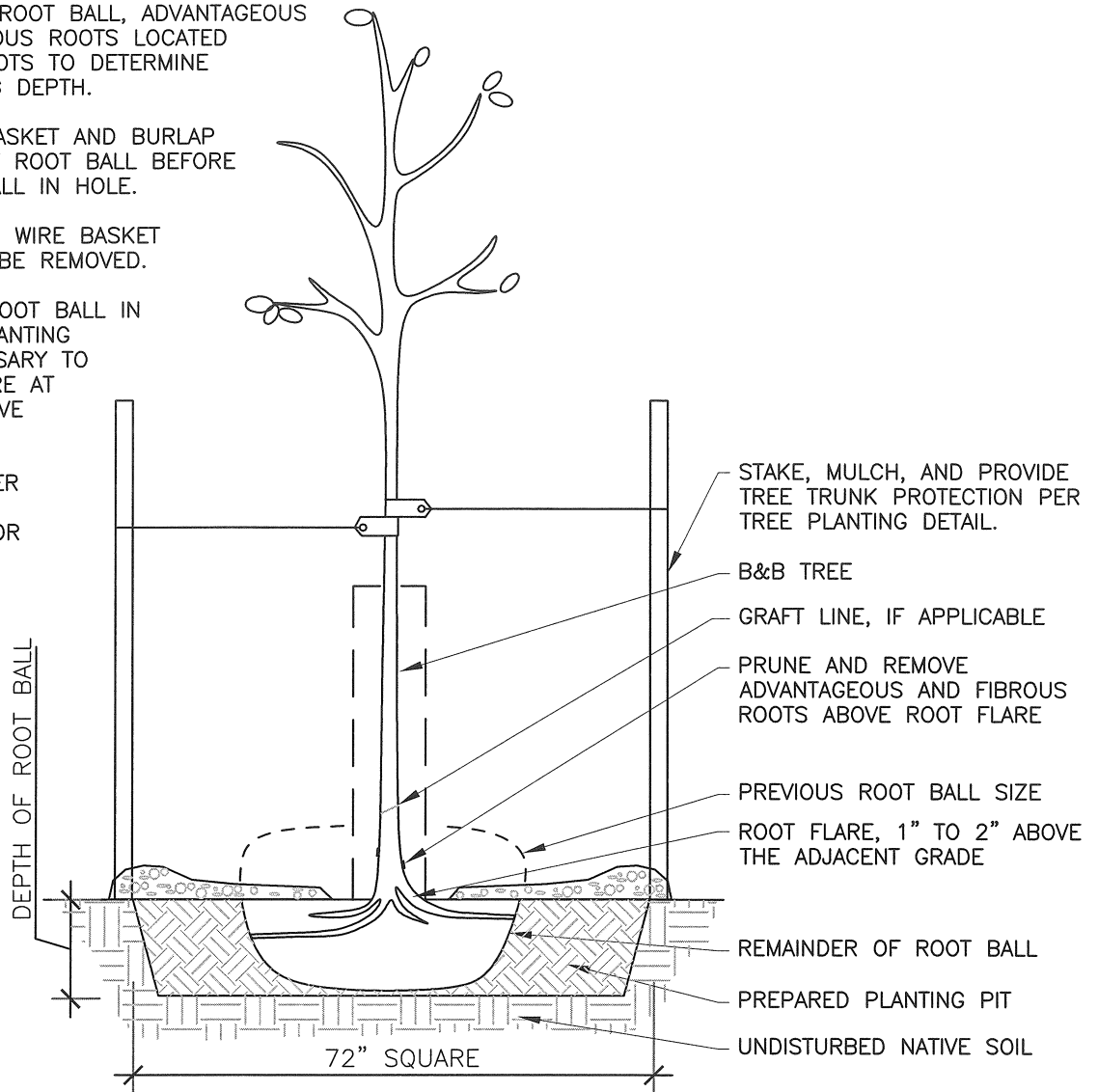

BALLED AND BURLAPPED (B&B) ROOT BALL PREPARATION AND PLANTING  
NOT TO SCALE

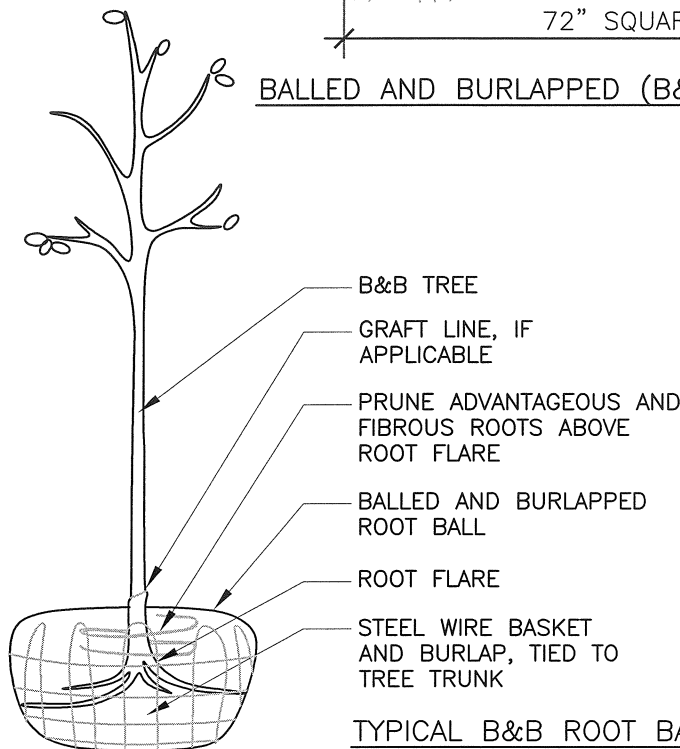

TYPICAL B&B ROOT BALL  
NOT TO SCALE

SECTION NO. 7000	DRAWING NO. 5.4
REV,D.	
<i><b>BALLED &amp; BURLAPPED (B&amp;B) TREE ROOTBALL PLANTING DETAIL</b></i>	
CITY OF FARGO ENGINEERING DEPARTMENT	
APPROVED <i>BED</i>	DATE <i>2-21-2012</i>

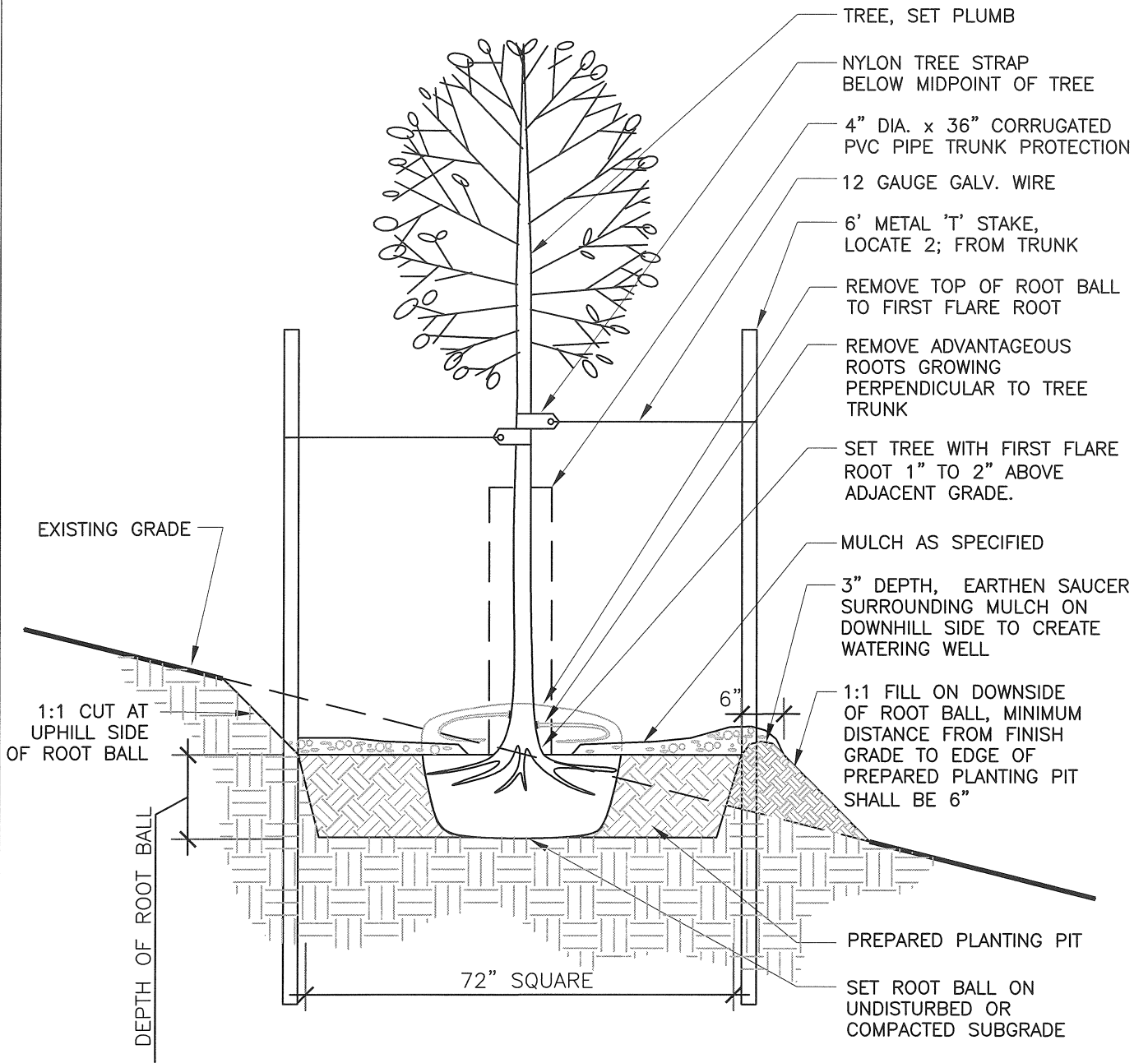

SECTION NO. 7000 | DRAWING NO. 5.5

REV, D.

*ON SLOPE  
TREE PLANTING DETAIL*

CITY OF FARGO  
ENGINEERING DEPARTMENT

APPROVED *BED*

DATE *2-21-2012*

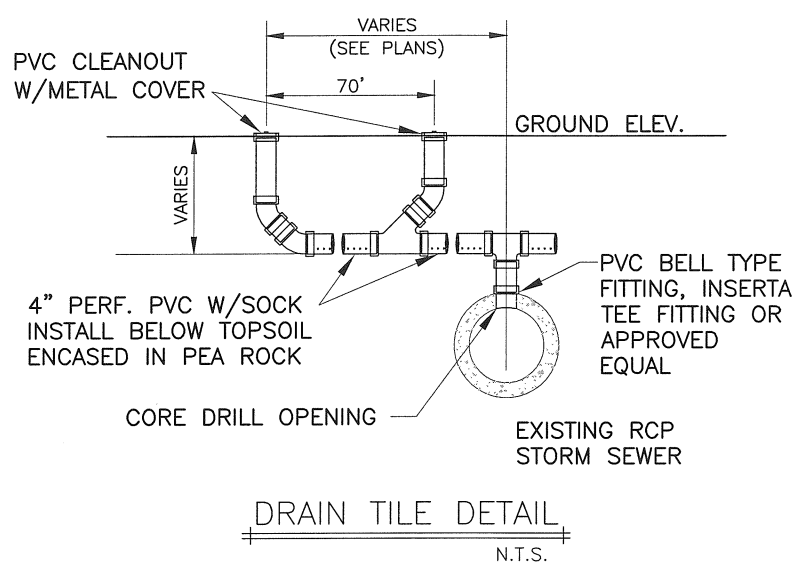
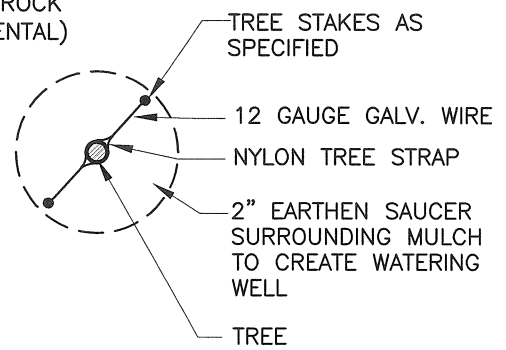
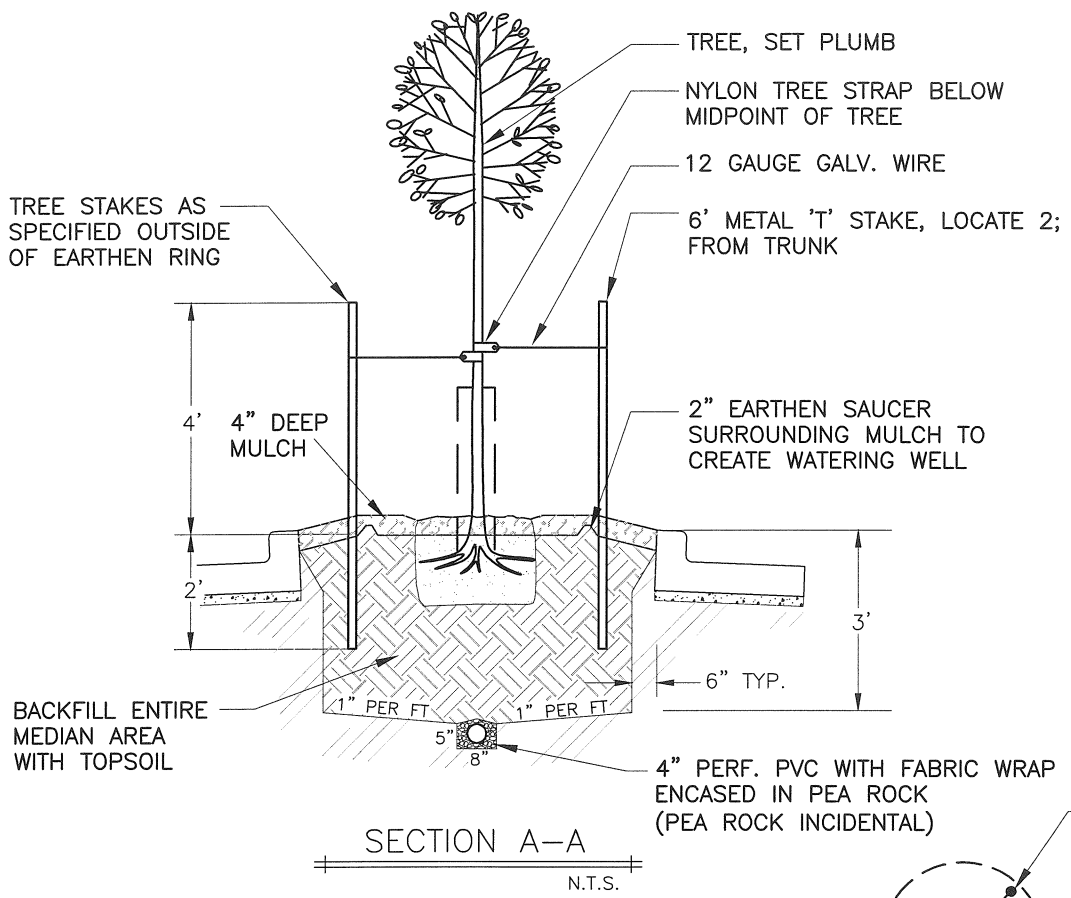
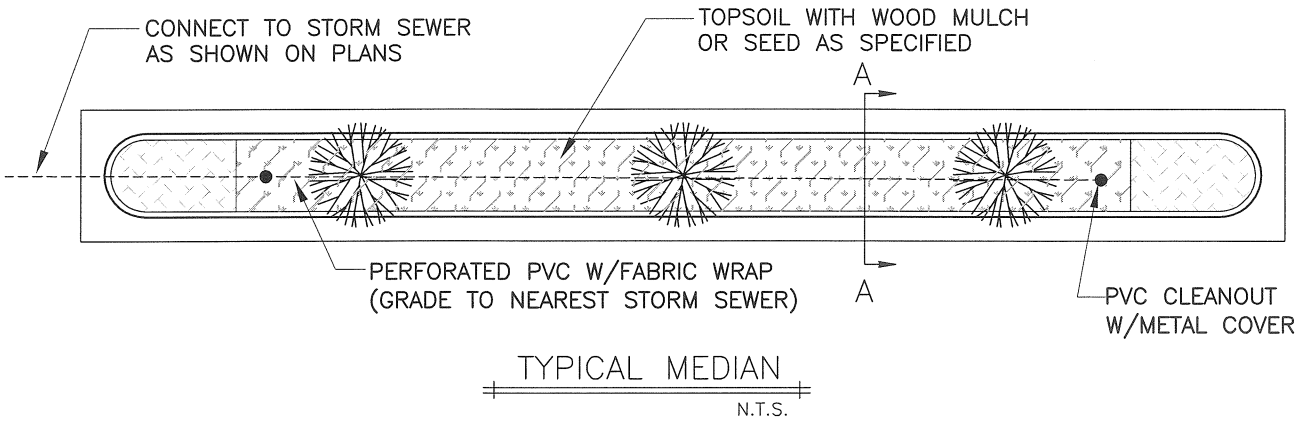

SECTION NO. 7000	DRAWING NO. 5.6
REV.D.	
<i>TYPICAL MEDIAN TREE PLANTING W/DRAIN TILE</i>	
CITY OF FARGO ENGINEERING DEPARTMENT	
APPROVED <i>BED</i>	DATE <i>2-21-2012</i>

NOTES:

1. COLOR TO BE POWDER COATED BLACK.
2. SURFACE MOUNT PER MANUFACTURES RECOMMENDATIONS.
3. CONCRETE TO BE 4,000 PSI WITH MEDIUM BROOM FINISH.
4. DOWEL INTO ADJACENT CONCRETE BIKE PATH WITH #4 DOWELS, 5 PER PAD.

6' BENCH –  
 WAUSAU TILE MODEL #MF2000,  
 SITESCAPES DLG MODEL #CVI-1000CF  
 DUMOR MODEL #93  
 OR APPROVED EQUAL

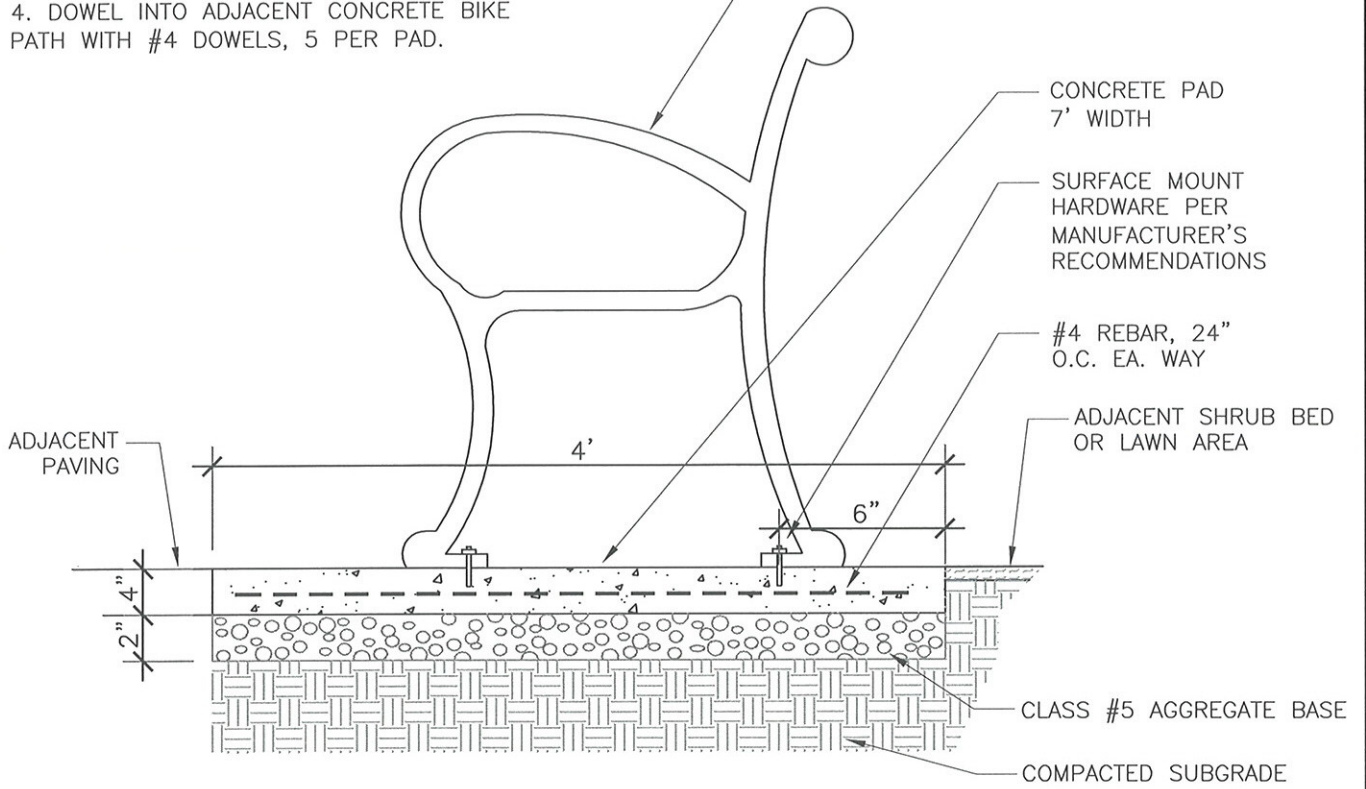

BENCH AND CONCRETE PAD DETAIL  
 NOT TO SCALE

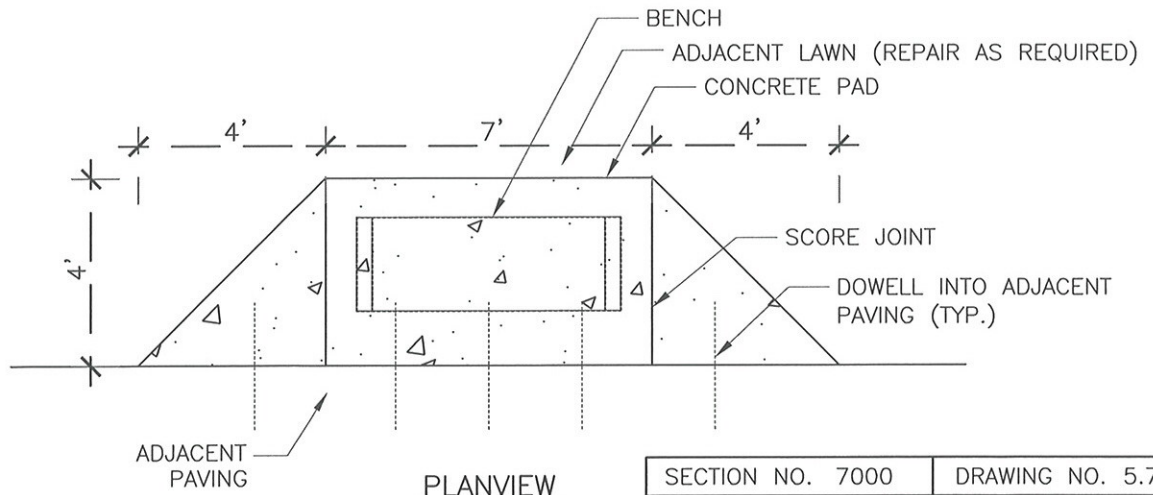

PLANVIEW  
 N.T.S.

SECTION NO. 7000	DRAWING NO. 5.7
REV.D. 2013	
<b>BENCH DETAIL</b>	
CITY OF FARGO ENGINEERING DEPARTMENT	
APPROVED <i>DME</i>	DATE 1-2-13

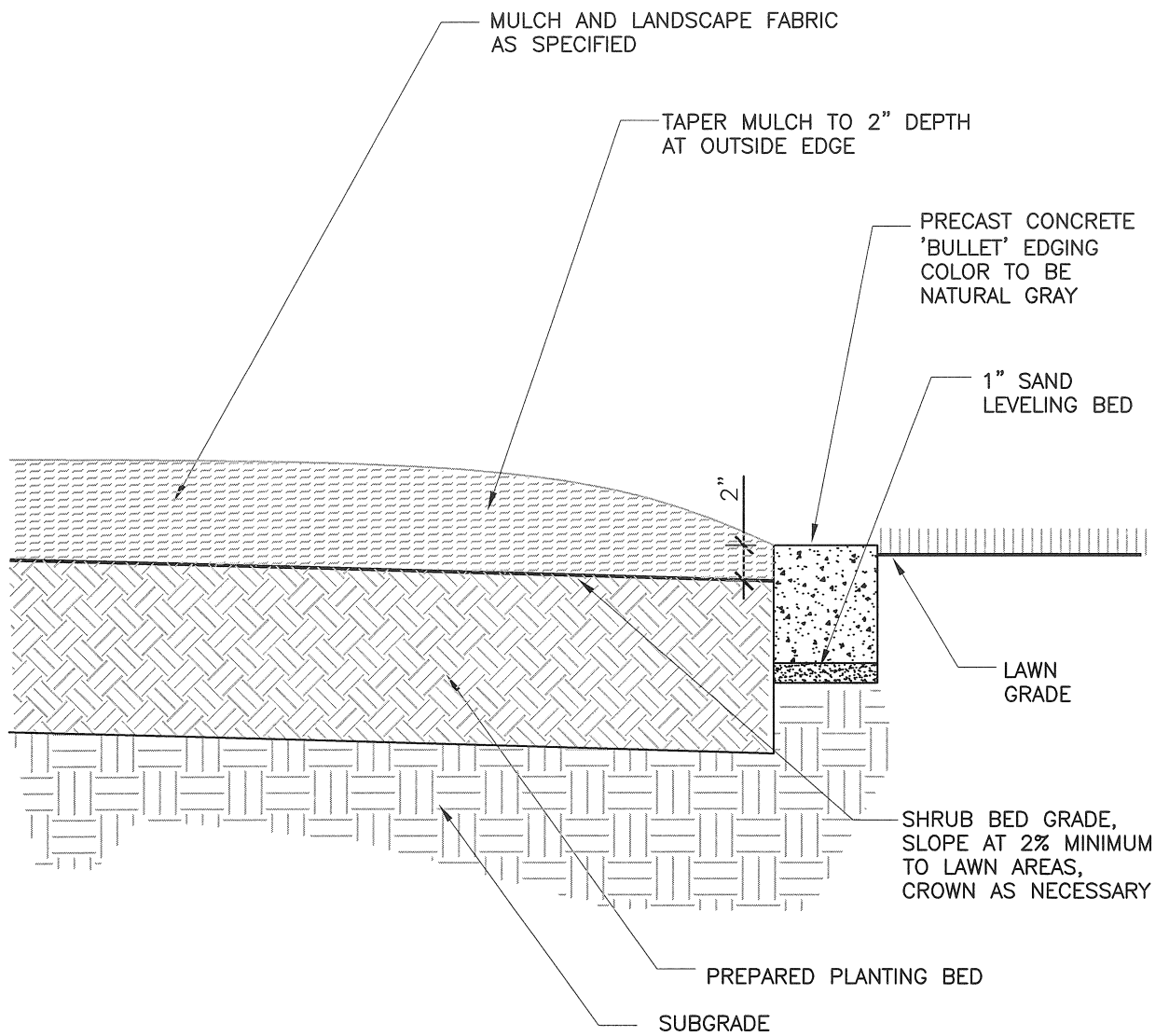

NOTES:

1. REFER TO SPECIFICATIONS FOR ADDITIONAL REQUIREMENTS.
2. INSTALL EDGING LEVEL, EVEN AND UNIFORM.

SECTION NO. 7000	DRAWING NO. 5.8
REV,D.	
<i>EDGING DETAIL</i>	
CITY OF FARGO ENGINEERING DEPARTMENT	
APPROVED <i>BED</i>	DATE <i>2-21-2012</i>

**CITY OF FARGO SPECIFICATIONS  
EXTRA WORK**

**PART 1  
DESCRIPTION OF WORK**

When directed in writing by the Engineer to do so, the Contractor shall furnish material and do extra work not otherwise provided for by the terms of the contract; but which may be connected with or necessary for the completion of the work. Such material and work shall be furnished and done as part of the contract and subject to its provisions and at such prices as may be agreed upon by the City Engineer and the Contractor.

The cost of the extra work will be determined by one or more of the following methods:

1. By an acceptable lump sum proposal from the Contractor.
2. By unit contract prices contained in the contract proposal, or by unit prices mutually agreed upon by the Contractor and the Engineer.
3. By Force Account.

It shall be the responsibility of the Contractor before proceeding with any change to satisfy himself that the change has been properly authorized on behalf of the City Engineer. No compensation for extra work or any other change in the contract will be allowed unless the extra work or change has been authorized in writing by the Engineer, and the compensation or method of determining such compensation is stated in such written authority.

**PART 2  
MATERIALS**

THIS SECTION NOT USED.

**PART 3  
CONSTRUCTION**

THIS SECTION NOT USED.



**PART 4**  
**GUARANTEE, MEASUREMENT & PAYMENT**

4.1. GUARANTEE

The guarantee shall be per the contract.

4.2. FORCE ACCOUNT

In the event of a disagreement, extra work shall be done on a force account basis and will be paid for in the manner hereinafter described, and the compensation thus provided shall be accepted by the Contractor as payment in full for the use of small tools, superintendents services, timekeeper's services, premium on bond, and all other overhead expenses incurred in the prosecution of the extra work done by a force account basis. Payment will be made as follows:

A. MATERIALS

For all materials purchased by the Contractor and used in this specific work, he will receive the actual cost of the material including freight charges, as shown on the original receipted bills for materials and freight, to which will be added the amount equal to 25% of the sum thereof, which will cover all profit and overhead.

B. LABOR

For all labor and foremen engaged in the specific operation, the Contractor will receive the wage prevailing and paid on the project for each and every hour that such labor and foreman are actually engaged in such work. In addition, the current payroll taxes, to include Workman's Compensation insurance premiums and the actual social security taxes computed on the base wage rate for the class of work involved, shall be added to the wages per hour. To the sum of the hourly wages and the payroll taxes, an amount equal to 25% of the sum thereof may be added, which will cover all profit and overhead.

Payrolls and affidavits will be required if the labor rates appear excessive.

C. EQUIPMENT RENTAL

The equipment rental rate without operator will be determined by the Rental Rate Blue Book published by the Equipment Guide Book Company. The monthly rate for the specific equipment used will be divided by 176 hours to determine the hourly rental rate. To this amount the estimated operating cost per hour will be added. The operator shall be included in the labor portion of the force account.

4.3. EXTRA WORK BY SUBCONTRACTORS

For any Force Account work performed by a Subcontractor with the written authorization of the Engineer, the Contractor will receive an additional allowance for administrative and overhead expense. The additional allowance will be a percentage of the Force Account work performed by the Subcontractor equal to 10% of the first \$10,000 plus 5% on the balance in excess of \$10,000

4.4. BILLS FOR EXTRA WORK

On or before the 30th day succeeding the completion of the extra work authorized by the Engineer with a "Contractor's Order", the Contractor shall present to the City Engineer the original "Contractor's Order" together with a full and complete itemized statement of such extra work, with the date of completion of the work mentioned therein, and upon certification by the City Engineer or his authorized representative as to the correctness of such items with regard to the amount and character of labor performed and materials furnished under such "Contractor's Order", the City Engineer shall enter the same as part of the estimate of the amount due the Contractor, and he shall not be entitled to pay for any such extra work in which he fails to present the "Contractor's Order" within the time and in the manner above mentioned.

The Contractor's itemized statement shall be prepared using the following sample extra order as a guide:

**ABC CONSTRUCTION CO.**  
**1234 AGREEABLE AVE.**  
**FARGO, N. D.**

JOB: Sanitary Sewer, Water Main,  
 & Storm Sewer - ID # 5001

LOCATION: Pleasant Addition

TO:

City of Fargo  
 City Engineer  
 City Hall  
 Fargo, ND

EXTRA ORDER NO. 1 DATE WORK PERFORMED: 7/12/2012

**DESCRIPTION OF EXTRA WORK COMPLETED:**

Relocate hydrant at Compliant Blvd. & Friendly St. S.

**MATERIALS:**

14' Of 6" PVC Watermain	@	\$20.00/LF =	\$280.00
26.5 Tons of Gravel Backfill	@	\$12.00/TN =	<u>\$318.00</u>
Subtotal			\$598.00
Plus 25% Overhead and Profit			<u>\$149.50</u>
<b>TOTAL MATERIALS</b>			<b>\$747.50</b>

**LABOR:**

Sam Spade	3 Hours @	\$30.00 =	\$ 90.00
Paul Maul	3 Hours @	\$24.00 =	\$ 72.00
Jake Rake	3 Hours @	\$20.00 =	\$ 60.00
Mike Spike	1.5 Hours @	\$16.00 =	<u>\$ 24.00</u>
Subtotal			\$246.00
Plus 24% Payroll Taxes			<u>\$ 59.04</u>
Subtotal			\$305.04
Plus 25% Overhead And Profit			<u>\$ 76.26</u>
<b>TOTAL LABOR</b>			<b>\$381.30</b>

**EQUIPMENT RENTAL:**

John Deere 160DLC	3 Hours @	\$82.52	<u>\$247.56</u>
(\$40.57 Base + \$41.95 Operating. Cost)			

**GRAND TOTAL LABOR, MATERIAL, & EQUIPMENT** **\$1,376.36**

**CITY OF FARGO SPECIFICATIONS  
BIDDING AND CONTRACT DOCUMENTS**

## GENERAL INSTRUCTIONS TO BIDDERS

- IB-1. EXAMINATION OF CONTRACT DOCUMENTS. Before submitting a Proposal, all Bidders shall examine the complete Contract documents, including Form of Proposal, Form of Bidder's Bond, Form of Contract Bond, Addenda, Contract and General and Detail Plans, **all of which are part of the Contract documents.**
- IB-2. DETERMINATION OF NON-RESPONSIBLE BIDDER. Contracts will not be awarded to any Bidder or Contractor who is determined to be not responsible by the City Commission of the City of Fargo.

A Contractor may be determined to be a non-responsible Bidder for any one or more of the following reasons:

1. Inadequate financial resources to perform the Contract;
  2. Inadequate experience, organization, or technical resources to perform the Contract;
  3. Uncompleted work which the City of Fargo (the "City") determines might hinder or prevent prompt completion of additional work;
  4. Default under previous or existing Contracts;
  5. Failure to repay monies due the City resulting from overpayments;
  6. Unsatisfactory performance on previous work or current contract(s), including but not limited to: (a) Noncompliance with contract requirements, or Engineer's directives; (b) failure to complete work on time; (c) instances of substantial corrective work prior to acceptance; (d) instances of completed work that requires acceptance at reduced pay; and (e) production of non-specification work or materials; and
  7. Any other facts or circumstances showing a reasonable likelihood of inability to perform the Contract.
- IB-3. ADDENDA. Answers to all questions, inquiries, and requests for additional information will be issued only to those obtaining documents. Bidders may, during the bidding period, be advised by addenda of additions, deletions from, or changes to the requirements of the Contract documents. The City is not responsible for the authenticity or correctness of oral interpretations of the Contract documents or for information obtained through other than addenda. Receipt of addenda shall be considered part of the Contract documents.

Questions concerning the Proposal must be made in writing at least forty-eight (48) hours in advance of the time set for bid opening, exclusive of Sundays and legal holidays. The City Engineer will respond in writing to all inquiries twenty (20) hours before the time set for bid opening to all Bidders or Contractors obtaining Contract documents. In no event will questions be answered if made within twenty-four (24) hours prior to bid opening.

- IB-4. INVESTIGATION BY BIDDERS. Bidders must satisfy themselves by personal investigation and by such other means as they may think necessary or desirable, as to the location of and the conditions affecting the proposed work and as to the cost thereof. No information derived from maps, plans, specifications, profiles, or drawings, or from verbal statements by any official and/or other representative of the City, will relieve the

Contractor from any risk or from fulfilling all of the terms of the Contract. The accuracy of the Contractor's interpretation of the facts disclosed by any preliminary investigations that may have been made by the City is not guaranteed. The Contractor shall not, at any time, make claims to additional payments or considerations on account of any misunderstanding regarding the nature or amount of the work to be done.

IB-4.1. Underground Utilities. Contractors are responsible for damage to any underground or overhead piping, wiring or other utility property, occurring during any excavation or construction by Contractor. The Contractor, before commencing any excavation or construction shall locate the previously mentioned underground property by contacting the following:

North Dakota One-Call

800-795-0555

IB-5. LEGAL CONDITIONS. Bidders are required to comply with the laws of the State of North Dakota and the City of Fargo Municipal Code.

IB-5.1. Federal Taxes. The City is exempt from Federal Tax on the transportation of property, and the Bidder or Contractor shall not include such taxes.

IB-5.2. State Taxes. The current income clearance number issued by the State Tax Department shall be furnished by the Contractor to the City.

IB-5.3. Addenda Acknowledgement, Bond, and License Requirements. All bids must be in a sealed envelope plainly marked with the name and number of the Improvement District or Project, and attached to the outside of the bid envelope must be **A SEPARATE ENVELOPE CONTAINING A LIST OF ALL ADDENDA TO THE PLANS AND SPECIFICATIONS AND AN ACKNOWLEDGEMENT BY THE BIDDER OF RECEIPT OF SUCH ADDENDA, AND THE CONTRACTOR'S LICENSE OR CERTIFICATE OF RENEWAL. THE SEPARATE ENVELOPE SHALL ALSO CONTAIN A BIDDER'S BOND IN THE AMOUNT OF 5% OF THE FULL AMOUNT OF THE BID** executed by the bidder as principal and by a surety, conditioned that if the principal's bid is accepted and the Contract awarded to the principal, the principal, within 10 days after notice of award, shall execute a Contract in accordance with the terms of the bid and a contractor's bond as required by law and the regulations and determinations of the City Commission. Countersignature of a bid bond is not required under this section.

All Bidders, except a bidder on a municipal, rural, and industrial water supply project authorized for funding under Public Law No. 99-294 [100 Stat. 426; 43 U.S.C. 390a], must be licensed for the full amount of the bid, as required by N.D. Cent. Code Section 43-07-05. A copy of the Contractor's License or Certificate of Renewal thereof, issued by the Secretary of State, must be enclosed in the bid bond envelope as required under N. D. Cent. Code Section 43-07-12. A Contractor must be the holder of a license at least ten (10) days prior to the date set for receiving bids to be a qualified bidder.

No bid may be read or considered if it does not fully comply with these requirements and any deficient bid submitted must be resealed and will be returned to the Bidder immediately.

The City Commission reserves the right to reject any and all bids and rebid the project until a satisfactory bid is received.

IB-6. FORMS OF PROPOSALS. All Proposals must be upon forms furnished by the City or a substitute computer-printed spreadsheet. The package must be enclosed in a sealed envelope and deposited with the City Auditor identifying the name of the Bidder and its contents. The Proposal must be signed by the principal or an authorized representative, with such authority properly evidenced.

IB-6.1 Computer-Printed Bid Schedule. The Bidder may substitute a computer-printed spreadsheet bid schedule for the Bid Schedule found in the Proposal. The substitute schedule shall be attached to the last page of the Bid Schedule in the Bidder's Proposal.

The following information shall appear on top of each page of the computer-printed bid schedule:

1. Improvement District Number or Project Number;
2. Type, Description of Work (i.e., Sanitary Sewer, Water Main, Storm Sewer and Incidentals);
3. Page Number; and
4. Bidder's Name and Address.

The substitute bid schedule shall be printed on 8 ½ "x 11" paper and the words and numerals shall be clear and legible. Each page shall be numbered, and contain the same bid items as the corresponding Bid Schedule in the Proposal. Column headings shall be the same as those in the City-furnished Bid Schedule.

Each bid item shall be separated from the bid items above and below it by one or more blank spaces. Solid lines for separating columns and items are not required, but dashed lines may be placed either vertically or horizontally.

The total sum of the bid shall be entered at the bottom of the last page of the computer-printed schedule, and entered in ink in the Total Sum Bid block on the last page of the City's Bid Schedule.

The Bidder, or authorized representative, shall sign the substitute bid schedule in ink on the last page of the computer printout. The signer's name and title shall be printed below or beside the signature. The person signing the schedule shall sign and complete the Affidavit in the Bidder's Proposal.

In case of discrepancies between item descriptions or quantities in the Bid Schedule in the Proposal and those in the computer-printed bid schedule, the Bid Schedule in the Proposal will govern.

IB-7. FILLING IN BIDS. All prices must fully cover all items for which Proposals are herein asked. Any Proposal submitted on items not included in the proposal form shall be grounds for rejection of the entire proposal.

IB-8. CAUSES OF REJECTION. The City Commission may reject any and all bids if in its opinion the best interests of the City will be served thereby. Bids may be considered irregular and may be rejected if:

1. The Proposal is not properly signed.
2. The Bidder fails to provide any of the required documents.
3. There are unauthorized additions, conditional or alternate bids, or irregularities of any kind which may make the Proposal's meaning incomplete, indefinite, or ambiguous.
4. A price per unit cannot be determined from the Proposal, except in the case of authorized alternate pay items.
5. It is determined that the unit prices are materially unbalanced to the potential detriment of the City.

IB-9. WITHDRAWALS. A bid may be withdrawn at any time prior to the expiration of the period during which Proposals may be submitted by written request of the Bidder, to the City Auditor, which request must be signed in the same manner and by the same person or persons who signed the Proposal. No bid can be withdrawn thereafter.

IB-10. BIDDER'S BOND. Each Proposal shall be accompanied by a bond to the City. Such bond shall be enclosed in the separate sealed envelope with the Contractor's license and addenda acknowledgement documents. The amount of the bond shall be at least 5% of the amount of the bid.

Said bond shall be executed by the Bidder or Contractor as principal and a surety company authorized to do business in the State of North Dakota as surety.

IB-11. CONTRACT. The successful Bidder will be required to execute a written Contract and furnish a good and approved bond as herein specified within ten (10) days after receiving such Contract for execution. The Contract shall be, in its general provisions, in the form attached hereto and made a part of these requirements.

A corporation to which a Contract is awarded will, before the Contract is finally executed, if deemed desirable by the City Commission, be required to furnish certificates as to its corporate existence and evidence that the officer signing the Contract is duly authorized to do so on behalf of the corporation.

IB-12. CONTRACT BOND. The successful Bidder shall, within ten (10) days or such time as may be fixed by the City Commission for executing the Contract, file a contract bond with the City Auditor in a sum equal to the full amount of the Contract. Said bond shall be executed by the Bidder or Contractor as principal and a surety company authorized to do business in the State of North Dakota as surety.



The contract bond shall be made payable to the City and shall be conditioned on the Contractor's full and faithful performance of the work bid. In the event of default, the bond shall be taken and held to be fixed and liquidated damages in favor of the City and the full amount thereof may be recovered from the Contractor and its sureties in an action by the City against them on their bonds. The sufficiency of any bond filed by a Contractor shall be determined by the City Commission at the time of considering bids. If the City Commission shall at any time deem the bond of the Contractor insufficient, either in form or sufficiency of sureties, it may require the successful Bidder or Contractor to furnish a new bond. Said bond to be approved by the City Commission, within such reasonable time as the City Commission may fix and if the Bidder or Contractor shall fail to furnish such new bond within the time required after notice to do so, the Contract shall be cancelled and the contractor's bond shall be liable the same as if the Contractor had failed to perform the Contract.

- IB-13. PATENTS AND INFRINGEMENTS. The successful Bidder must protect and indemnify the City against any claim or demand for infringements on any patented article, invention, arrangement or appurtenances that may be used in connection with the construction, erection or maintenance of this work.
- IB-14. INVITATIONS. Bidders are invited to be present at the opening of the Proposals.
- IB-15. ENFORCEMENT OF SPECIFICATIONS. Copies of the specifications and plans for this work will be supplied to all assistant engineers and inspectors employed by the City. All engineers and inspectors will rigidly enforce each and every requirement of the Contract.
- IB-16. COMPLIANCE WITH LABOR STANDARDS (DAVIS-BACON ACT) REQUIRED ON CONSTRUCTION PROJECTS FINANCED WITH FEDERAL FUNDS. Contractor must comply with all requirements of the Davis-Bacon Act on applicable projects.
- IB-17. EQUAL OPPORTUNITY REGULATIONS. Contractor will not discriminate against any employee or applicant for employment because of race, color, religion, sex, or national origin and will comply with all employment laws and regulations. Failure to do so may result in termination of the Contract and a claim against the bond. Contractor agrees to post in conspicuous places, available to employees and applicants for employment, notices setting forth the provisions of this nondiscrimination clause.
- IB-18. COMPLIANCE WITH ENVIRONMENTAL PROTECTION REGULATIONS. Bidders are required to comply with all applicable pollution control and environmental protection regulations.
- IB-19. INSURANCE. Contractor shall secure insurance against hazards as enumerated herein. All policies shall be with companies satisfactory to the City and in amount and form as specified.

All certificates of insurance shall be on the form provided herein, and the said certificate shall state that ten (10) days written notice will be given to the City before the policy is cancelled or changed.

No Contractor or Subcontractor will be permitted to start any construction under the terms of the Contract until a certificate of all insurance as required herein is filed with the City.

IB-19.1. Public Liability and Property Damage. Contractor shall provide public liability and property damage insurance against risks resulting from the following:

- A. Operations of Contractor;
- B. Operations of Subcontractors (contingent);
- C. Completed operations;
- D. Contractual Liability (broad form); and
- E. Property damage liability including:
  - 1. Damage due to blasting;
  - 2. Damage due to collapse;
  - 3. Damage to underground facilities; and
  - 4. Broad form property damage:
    - a. Premises and operations
    - b. Contractual

The liability limits of said insurance shall be as follows:

- A. Bodily Injury
  - 1. \$1,000,000 each person
  - 2. \$1,000,000 each occurrence
  - 3. \$2,000,000 aggregate
- B. Property Damage
  - 1. \$1,000,000 each occurrence
  - 2. \$1,000,000 aggregate
  - 3. \$2,000,000 aggregate (property damage auto)

IB-19.2. Automobile Liability. The Contractor shall provide automobile liability insurance covering operation of all vehicles which are either hired, owned, or non-owned as follows:

- A. Bodily Injury
  - 1. \$1,000,000 each person
  - 2. \$1,000,000 each occurrence
- B. Property Damage Liability
  - 1. \$1,000,000 each occurrence

IB-19.3. Workmen's Compensation. The Contractor shall be insured against liability for injury to employees in accordance with the laws of the State of North Dakota. A coverage certificate shall be furnished to the City prior to the commencement of any work.

IB-19.4. Railroad Protective Liability. In the event the contemplated project encroaches on any railroad sufficiently to require permission for construction from the railroad, the successful Bidder will be required to furnish to the railroad a Railroad Protective Liability Insurance Policy in a form acceptable to that railroad.

CERTIFICATE OF INSURANCE

This is to certify that the following policies, subject to their terms, conditions and exclusions have been issued by the named companies:

Project \_\_\_\_\_  
Location \_\_\_\_\_  
Owner \_\_\_\_\_  
Contractor \_\_\_\_\_  
Architect/Engineer \_\_\_\_\_  
Insured \_\_\_\_\_  
Address \_\_\_\_\_

The following named policies meet the minimum requirements of the specifications:

Yes \_\_\_\_\_ No \_\_\_\_\_

PUBLIC LIABILITY:

Policy Number \_\_\_\_\_ Inception Date \_\_\_\_\_  
Expiration Date \_\_\_\_\_  
Insuring Company \_\_\_\_\_  
Address \_\_\_\_\_  
Agent \_\_\_\_\_  
Address \_\_\_\_\_

TYPE OF POLICY: Combination comprehensive general automobile

Liability \_\_\_\_\_  
Other \_\_\_\_\_

LIMITS:

Bodily Injury \$ \_\_\_\_\_ Each Person  
\$ \_\_\_\_\_ Each Occurrence  
\$ \_\_\_\_\_ Aggregate  
\$ \_\_\_\_\_ Each Person  
\$ \_\_\_\_\_ Each Occurrence

COVERAGE PROVIDED:

	<u>YES</u>	<u>NO</u>
Operations of Contractor	_____	_____
Operations of Sub-Contractor (contingent)	_____	_____
Completed Operations	_____	_____
Contractual Liability (broad form)	_____	_____

LIMITS:

Property Damage \$ \_\_\_\_\_ Each Occurrence  
 \$ \_\_\_\_\_ Aggregate  
 Property Damage Auto \$ \_\_\_\_\_ Each Occurrence  
 -or-  
 Combined Single Limit \$ \_\_\_\_\_ Each Occurrence

COVERAGE PROVIDED:

Property Damage Liability Includes:

	<u>YES</u>	<u>NO</u>
Damage due to blasting	_____	_____
Damage due to collapse	_____	_____
Damage to underground facilities	_____	_____
Broad Form Property Damage: premises and operations	_____	_____
contractual	_____	_____

AUTOMOBILE LIABILITY:

Policy Number \_\_\_\_\_ Inception Date \_\_\_\_\_  
 Expiration Date \_\_\_\_\_  
 Insuring Company \_\_\_\_\_  
 Address \_\_\_\_\_  
 Agent \_\_\_\_\_  
 Address \_\_\_\_\_

Limits of Liability:

Bodily Injury Liability \$ \_\_\_\_\_ Each Person  
 \$ \_\_\_\_\_ Each Occurrence  
 Property Damage Liability \$ \_\_\_\_\_ Each Occurrence  
 Combined Single Limit \$ \_\_\_\_\_ Each Occurrence

Coverage is provided for operation of all owned vehicles **Yes** \_\_\_\_\_ **No** \_\_\_\_\_

Coverage is provided for operation of all hired and non-owned vehicles **Yes** \_\_\_\_\_ **No** \_\_\_\_\_

Are any deductibles to Bodily Injury or Property Damage **Yes** \_\_\_\_\_ **No** \_\_\_\_\_

If yes, list

\_\_\_\_\_  
\_\_\_\_\_

AGENT CARRIES ERRORS AND OMISSIONS INSURANCE **Yes** \_\_\_\_\_ **No** \_\_\_\_\_

In the event of cancellation, non-renewal or any material change in the above policies, fifteen days prior notice will be given to the parties to whom this certificate is issued.

DATE AT \_\_\_\_\_ ON \_\_\_\_\_

BY \_\_\_\_\_

Authorized Insurance Representative

**PROPOSAL**

CITY OF \_\_\_\_\_

COUNTY OF \_\_\_\_\_

STATE OF \_\_\_\_\_

To the Honorable  
Board of City Commissioners  
City of Fargo, County of Cass  
State of North Dakota

The undersigned, after having personally examined the plans, specifications, form of contract, and bond on file in the office of the City Auditor and carefully investigated the proposed work, proposes to do all of said work of furnishing materials and constructing

\_\_\_\_\_  
\_\_\_\_\_  
\_\_\_\_\_

The undersigned further agrees to fully complete all such work, ready for use, including the furnishing of all materials, tools, labor, and all and everything necessary to finish and maintain the entire work in a proper and workmanlike manner until finally approved and accepted by the City Commissioners and City Engineer in accordance with the contract and under penalty of the contract bond.

The undersigned further proposes and agrees to comply with all legal requirements of contractors on public projects.

This proposal is made without connection or consultation with any other person, persons, or corporation making any other bid for the same purpose, and it is in all respects fair and without collusion or fraud.

This project is to be completed in accordance with the prices stated on the following bid sheets:

Bidders are cautioned to exercise extreme care in preparation of their bids. Bids will be evaluated on the basis of unit prices, extensions, and totals. Arithmetic discrepancies found on the face of the Bid Schedule shall be resolved as follows:

1. In case of discrepancy between unit price and extended price, the unit price will govern.

Award will be made to the responsible bidder having the lowest verified grand total bid.

The \_\_\_\_\_ Company of \_\_\_\_\_ is hereby offered as surety for the execution of the proposed contract and the guarantee therein imposed, said surety being subject to the approval of the Board of City Commissioners. If not approved, another and satisfactory surety company will be furnished.

It is hereby agreed that the City of Fargo has the right to reject this proposal or to award the work to the undersigned at the prices stipulated. If this proposal is rejected, then the bond which is made payable to the City Treasurer of the City of Fargo shall be returned to the undersigned within thirty (30) days after the date hereof. If this proposal is accepted and the work awarded and the undersigned shall fail to enter into a contract of the form and terms hereto attached within ten (10) days after the award of the contract shall have been made, then the said bond shall be cashed and paid into the treasury of the City of Fargo as liquidated damages for the failure of the undersigned to comply with the terms of this proposal.

(Here sign full name and give place of business or place of residence of bidder.)

Bidder's Names in Full \_\_\_\_\_

Business or Residence Address \_\_\_\_\_

(Here give the name and place of business or place of residence of all persons or corporations interested with the bidder.)

Name \_\_\_\_\_

Business or Residence Address \_\_\_\_\_

(If no such person, persons or corporations are so interested, distinctly write out the fact on the following lines.)

\_\_\_\_\_  
\_\_\_\_\_

(Here give the name and location of the last work of the kind herein contemplated which was accomplished by the bidder.)

\_\_\_\_\_  
\_\_\_\_\_

(As to this work, the bidder refers to the following persons or corporations.)

Name \_\_\_\_\_

Address \_\_\_\_\_

The undersigned further proposes and agrees to fully complete the contract on or before the completion date(s) specified in the bidding documents.

The various items in the preliminary estimate may be increased, decreased, or may not occur in the final estimate upon which payment to the contractor will be made. Such variations will be based upon actual quantities constructed, and such variations from the estimated quantities shall occur only for the betterment of the project.

The undersigned is duly and regularly licensed as required by the laws of North Dakota, and holds a Class \_\_\_\_\_ Contractor's License No. \_\_\_\_\_.

(If this proposal is made by a firm or by a corporation, the firm or corporation names must be here signed by one duly authorized to do so.)

Bidder \_\_\_\_\_  
\_\_\_\_\_  
\_\_\_\_\_

Dated at \_\_\_\_\_ this \_\_\_\_ day of \_\_\_\_\_ 20 \_\_\_\_.

Post Office address of bidder, firm, or corporation for the next thirty days is as follows, to-wit:

\_\_\_\_\_  
\_\_\_\_\_  
\_\_\_\_\_



**BIDDER'S BOND**

KNOW ALL MEN BY THESE PRESENTS:

That we, \_\_\_\_\_ of the City of \_\_\_\_\_  
County of \_\_\_\_\_ State of \_\_\_\_\_ as principal, and  
\_\_\_\_\_ a \_\_\_\_\_  
Corporation, of \_\_\_\_\_ as surety, are held and firmly bound unto the City of Fargo, a  
municipal corporation, in the penal sum of \_\_\_\_\_ dollars, good and  
lawful money of the United States, for the payment of which sum, will and truly to be made, we bind  
ourselves, our heirs, executors, administrators, successors and assigns, jointly and severally by these  
present.

The contractor of the above obligation is such that, whereas, the above bounden  
\_\_\_\_\_ has submitted or is about to submit a sealed bid or proposal in writing  
for the construction of certain  
\_\_\_\_\_

\_\_\_\_\_ in accordance with the plans and specifications therefore on file in the office of the City Auditor, City  
Hall, Fargo, North Dakota, and pursuant to the true intent, meaning and purposes of such plans and  
specifications.

NOW THEREFORE, in case such bid is accepted, and the contract for such work is awarded to such  
bidder and the said bidder shall, within ten days after the acceptance of such bid, or within such further  
time as may be granted, enter into and execute a contract bond, in such sum equal to the amount of said  
bid, and a contract in writing to and with the said City of Fargo to well and faithfully do and complete  
the said work in accordance with the plans and specifications therefore, and the terms of such bid or  
proposal, and within the time required by the terms of said contract or any extension thereof and that  
\_\_\_\_\_ will pay for all labor and materials used in said  
work, then this obligation to be void, otherwise to be and remain in full force and effect.

The term of this bond expires on the \_\_\_\_\_ day of \_\_\_\_\_, 20\_\_\_\_, but a recovery may be had  
for any default hereunder if an action therefore be commenced at any time within six years after the  
expiration of such term.

IN WITNESS WHEREOF, the said \_\_\_\_\_ has hereunto set his hand, and  
the said \_\_\_\_\_ has caused these presents to be executed by its proper officers and  
its corporate seal to be hereunto affixed this \_\_\_\_\_ day of \_\_\_\_\_, A.D., 20\_\_\_\_.

Principal: \_\_\_\_\_  
Surety: \_\_\_\_\_  
By: \_\_\_\_\_

ATTEST: Secretary: \_\_\_\_\_

INDIVIDUAL ACKNOWLEDGEMENT

STATE OF \_\_\_\_\_)

)ss

COUNTY OF \_\_\_\_\_)

On this \_\_\_\_\_ day of \_\_\_\_\_ in the year 20\_\_\_\_\_ before me, \_\_\_\_\_,  
a Notary Public, personally appeared \_\_\_\_\_, known to me (or proved to me on the  
oath of \_\_\_\_\_) to be the person who is described in and who executed  
the within instrument and acknowledged to me that is executed the same.

(SEAL)

Notary Public : \_\_\_\_\_

CORPORATION ACKNOWLEDGEMENT

STATE OF \_\_\_\_\_)

)ss

COUNTY OF \_\_\_\_\_)

On this \_\_\_\_\_ day of \_\_\_\_\_ in the year 20\_\_\_\_\_ before me, \_\_\_\_\_,  
a Notary Public, personally appeared \_\_\_\_\_ known to me (or  
proved to me on the oath of \_\_\_\_\_) to be the president (or other officer or  
person) of the corporation that is described in and that executed the within instrument, and acknowledged  
to me that such corporation executed the same.

(SEAL)

Notary Public : \_\_\_\_\_

ACKNOWLEDGEMENT OF SURETY

STATE OF \_\_\_\_\_)

)ss

COUNTY OF \_\_\_\_\_)

On this \_\_\_\_\_ day of \_\_\_\_\_ in the year 20\_\_\_\_\_ before me, \_\_\_\_\_,  
a Notary Public, personally appeared \_\_\_\_\_, known to me (or  
proved to me on the oath of \_\_\_\_\_) to be the person who is described in  
and whose name is subscribed to the within instrument as the attorney-in-fact of \_\_\_\_\_  
and acknowledged to me that he subscribed the name of \_\_\_\_\_thereto as surety and his own  
name as attorney-in-fact.

(SEAL)

Notary Public : \_\_\_\_\_

## CONTRACT

THIS AGREEMENT, made and entered into this \_\_\_\_ day of \_\_\_\_\_, 20\_\_\_\_, between the City of Fargo (a Municipal Corporation, under the laws of North Dakota) by the City Commission, hereinafter called the City, and Contractor.

Contractor is hereby awarded the Contract to construct **Project Name, Improvement District No. Improvement District Number** in accordance with the attached Proposal. Contractor agrees to undertake and execute all work in a good, substantial and workmanlike manner, and to furnish all the materials, tools and labor necessary to properly perform and complete the work ready for use, in strict accordance with the Special Instructions to Bidders and the plans mentioned therein and the City of Fargo Standard Specifications for Construction in effect at the time of the bid opening, and under penalty expressed in the attached bond, which are hereby declared and accepted as essential parts of the unit prices named in the Proposal.

### What the Contract Price Includes

The price in the Proposal is for the completed work, and includes the furnishing of all the materials, labor, tools and appliances, and all expenses, direct and indirect, connected with the proper execution of the work in accordance with the plans, profiles and specifications for the work, and maintaining the same until it is accepted by the City Commission.

### Extra Work Part of Contract

When directed in writing by the City Engineer or an authorized representative ("City Engineer" inclusively) to do so, the Contractor shall furnish material and do extra work connected with or necessary to the proper completion of the work. Prices for extra work will be agreed upon by the City Engineer or an authorized representative and the Contractor as specified in Section 9000 of the Standard Specifications for Construction.

### Bills for Extra Work

Within thirty (30) days of completion of the extra work authorized by "Contractors Order," as defined in the City of Fargo Standard Specifications for Construction, the Contractor shall present to the City Engineer or an authorized representative the "Contractor's Order," and a full and complete itemized statement of extra work, and the date the extra work was completed. City Engineer or an authorized representative shall certify the correctness of the amount and character of labor performed and materials furnished and add it to the estimate of the amount due the Contractor. A "Contractor's Order" for extra work not presented within 30 days of completion will not be paid.

### Inspection

All materials furnished by the Contractor are subject to the inspection and approval of the City Engineer or an authorized representative at all times during the progress of the work, and until the final completion of the same. Contractor shall allow sufficient time to enable the City Engineer or an authorized representative to make the proper tests and inspection. As soon as the materials are tested and inspected, the Contractor shall immediately remove all rejected materials from the work and to such a point distant there from as the City Engineer or authorized representative may require. No materials shall be used before being inspected and approved by the City Engineer or authorized representative. Failure of the City Engineer or authorized representative to condemn or reject inferior materials or work does not imply acceptance of the same should their inferiority become evident at any time.

The Contractor shall furnish at their own expense such labor as may be required to enable a thorough inspection and culling of all materials.

Obstruction, Guard and Contractor's Liability

The Contractor shall follow Section 4100 of the Standard Specifications for Construction in all cases to maintain a safe passageway at all road crossings, crosswalks and street intersections, and shall do all other things necessary to prevent accidents or loss of any kind, and shall save the City harmless forever from any and all damages, costs, and expenses resulting from the neglect or failure of the Contractor in the performance of this Contract, to properly protect the public and employees from injury to person or property.

Property Liable to Damages

The Contractor shall be liable for any and all damage to public and private utilities, including but not limited to, water, gas, steam or other pipes, flumes, poles or conduits or other property owned by any person or corporation. Contractor shall have ten (10) days following notice from the City to repair or replace the damaged property. After ten (10) days City may arrange for such repairs or replacements to be made as necessary and deduct from any sum or sums due or to become due Contractor under this Contract the cost thereof.

The Contractor will be responsible for all survey irons and monuments, and if disturbed they will be replaced by a Registered Land Surveyor of the State of North Dakota, at the Contractor's own expense.

Contractor is responsible for damage to any underground or overhead piping, wiring, or other utility property occurring during any excavation or construction by Contractor. The Contractor, before commencing any excavation or construction, shall locate the previously mentioned underground property by contacting the following:

ND One Call..... 1-800-795-0555

Time of Commencement and Completion

The Contractor shall commence the work within thirty (30) days after written notice from the City, continue the work without interruption, and complete the entire Contract on or before **Completion Date**. Contractor's failure to satisfactorily and timely complete the Contract work shall result in a deduction by City, out of the money which may be due or become due Contractor liquidated damages in accordance with the agreed upon schedule attached hereto as Exhibit "A", fixed and determined by the parties to be liquidated damages.

Substantial completion shall consist of the following items unless otherwise noted in the Special Instructions to Bidders:

1. Projects with underground utilities: Substantial completion shall consist of the installation of all main line sewer, water, storm sewer pipe. Installation shall include testing of water main and sanitary sewer and installation of sewer and water services. All underground utilities shall be functional.
2. Projects with paving; Substantial completion requires that the curb and gutter and paving section be installed and functional. This includes driveways, sidewalks, finish grading, street lights, and signals.
3. In all other projects: Substantial completion shall mean that the specified improvement is operational and/or functional.

Final completion shall consist of completing remaining items and the repair of all punch list and clean up items.

At any time before expiration of the original or extended Contract time, a written request may be made to the City Engineer for additional time to complete the Contract. The request shall be supported by adequate documentation stating the reasons and basis for the request. The City Engineer's determination will consider to what extent the delays were caused by conditions beyond the Contractor's control that may be offset by time lost due to the failure to diligently prosecute the work or to other conditions within

the Contractor's control. A plea that insufficient time was specified is not a valid reason for a time extension. A time extension will not be considered for inclement weather or for the time period from November 15 to April 15.

Contractor must pay City liquidated damages for failure to timely complete the Contract work irrespective of whether there are monies due on the Contract.

#### Claim for Damages

Delay occasioned by any act or omission over which the Contractor has no control, or on the part of the City, may entitle the Contractor to an extension of time in which to complete the work. Contractor shall give notice in writing to the City Commission of the cause of such delay within thirty (30) days, yet in no case after the expiration of the original or extended Contract time.

#### Subletting

The Contractor shall not assign or sublet the whole or any portion of the Contract work (except for the supply of materials, equipment and tools) without first obtaining the written consent of the City Engineer. Consent given does not release the Contractor from responsibility. Contractor shall be held accountable the same as if no consent had been given. The Contractor will be required to give their personal attention to the work.

#### Specifications, Plans and Stakes

The work shall be done in strict conformity to the plans, profiles and specifications and to the exact lines and grades as defined by the City Engineer.

#### Cleaning Up

Immediately upon the completion of the work on each block, the Contractor shall at their cost and expense, clean up and remove all refuse materials of every kind resulting from the work. If Contractor fails to clean up and remove refuse within twenty-four (24) hours after having been notified by the City Engineer or authorized representative, the work may be done by the City and the cost thereof charged to the Contractor or deducted from the amount due the Contractor on their estimate.

#### Orders

Whenever the Contractor is not present on any part of the work where it may be necessary to give instructions, orders may be given by the City Engineer or authorized representative to the superintendent or foreman who may have charge of the particular work in question, and such orders shall be obeyed.

#### Defective Work

The Contractor, upon being so directed by the City Engineer or authorized representative, shall suspend, remove or reconstruct, or make good without charge any work which they may consider to be defectively executed.

#### Competent Workers to be Employed

The Contractor shall provide and have at all times a competent Superintendent in charge of the overall Project who will be personally available at the site of the work within 24 hours notice. This Superintendent may be either the Contractor himself or a responsible employee who has been authorized to act in the Contractor's behalf. This individual shall be fully authorized to:

- (a) Conduct all business with the subcontractors.
- (b) Negotiate and execute all Contract change orders or directly coordinate with the Contractor on such matters.
- (c) Execute the orders and directions of the Engineer or authorized representative without delay.
- (d) Promptly supply the materials, equipment, tools, labor, and incidentals necessary for prosecution of the work.

At all times while work is actually being performed, the Contractor shall have at the site of the work a competent individual who is:

- (a) Authorized and fully capable of managing, directing, and coordinating the work in progress.
- (b) Thoroughly experienced in the type of work being performed.
- (c) Capable of reading and thoroughly understanding the Plans and Specifications.
- (d) Authorized to receive instructions from the Engineer or authorized representative.

If this individual is an employee of someone other than the Contractor, the Contractor shall notify the Engineer or authorized representative as to who will act in the supervisory capacity stated above. This individual and the Superintendent having overall responsibility for the Project may be one and the same person if constantly available in person on the Project and fully qualified in all other respects.

If any person employed by the Contractor appears incompetent, disorderly, or disobedient to the City Engineer or authorized representative, they shall be discharged immediately upon request of the City Engineer or authorized representative and shall not again be employed upon the work without the consent of the City Engineer or authorized representative.

Contractor must give preference in accordance with N. D. Cent. Code section 43-07-20 to the employment of bona fide North Dakota residents, as determined by section 54-01-26, with preference given first to honorably discharged disabled veterans and veterans of the armed forces of the United States, as defined in section 37-19.1-01, who are deemed to be qualified in the performance of that work.

#### Order of Executing Work

The Contractor shall commence work at such point or points as the City Engineer or authorized representative may direct, and shall conform to their directions as to the order and time in which different parts of the work shall be done.

When a Contractor has more than one Contract with the City at the same time, they shall have sufficient workers, machinery, tools and material upon the work to complete each Contract in the manner and within the time specified in each separate Contract, and they shall not remove workers, machinery, tools or materials from one Contract job to another without the written consent of the City Engineer or authorized representative. Nor shall Contractor commence work on a new Contract job while in default on an existing Contract without the written permission of the City Engineer.

#### Failure to Pay for Labor and Materials

If Contractor fails to pay laborers, or for materials used, the City may make such payments from monies due the Contractor, at the City's discretion necessary to protect laborers and material suppliers.

#### Laws and Ordinances to be Observed

Contractor must abide by all applicable laws. Contractor shall indemnify the City against all claims, damages, suits, actions and expenses, including reasonable attorney's fees to the property of the City of any person, caused by the negligence of the Contractor or their servants or employees in carrying out or attempting to carry out this Contract, and from claims made by laborers or others for injury sustained by reason of the negligence of the Contractor, their servants or employees, in the performance or attempted performance of this Contract. Contractor further shall indemnify the City from damages sustained by depositing materials to public injury or to the injury of any person or corporation, or resulting from the use of any patented material, implement or process which may be employed in executing the work under this Contract, including costs and expense of defense. Contractor shall be notified of the bringing of suit in such cases, and be permitted to defend the same, and City may withhold final payment of this Contract for the indemnity of the City.

Failure to Prosecute Work Vigorously

Contractor shall commence work under this Contract within thirty (30) days after being instructed to do so in a written notice from the City. Contractor’s failure to commence work as directed may be deemed a Contract breach, and the Contractor and surety shall be liable for the full amount of the Contract.

If, at any time during the prosecution of the work, in the opinion of the City Engineer, Contractor is not employing the necessary resources to timely complete the Contract, or performing in an un-workmanlike manner, City shall give Contractor and their surety five (5) days written notice to comply. Failure to comply may be deemed a Contract breach and the Contractor and surety shall be liable on their bond for the full amount of the Contract price.

The notice provided for in this section may be served upon the Contractor by delivering the same to any person in charge of the work, or by leaving the same at the office of the Contractor in Fargo; and upon the surety of the Contractor by leaving the same at the office of such surety in Fargo.

Neither the abandonment of this Contract by the Contractor, as herein provided, nor the declaration by the City that the same is forfeited, nor the doing of the said work by the bidder, shall release the surety of the Contractor from liability under this Contract.

Payments

The City may retain five percent (5%) of the amount due Contractor until the completion of the entire Contract work. In no case will the City Engineer make payment to a Contractor who is in default under the terms of the Contract unless expressly authorized by the Board of City Commissioners.

The Contractor shall be paid by the City according to the certified statement furnished by the City Engineer and approved by the City Commission, and the payment shall be made in warrants drawn on the Project Name, Improvement District No. Improvement District Number fund of said City, with interest at seven (7%) percent per annum or in cash as stated below. The City assumes and incurs no general liability under this Contract for any sum to be raised by general taxation and reserves the right, at its option, to sell such warrants for cash, and from the proceeds thereof pay the Contractor the amount due them under this Contract.

The retained amounts will be according to the following table:

<u>Percentage of Completion</u>	<u>Percent Retained</u>
0 – 90%	5%
91 – 100%	1 – 5%*

\*Reduction of retainage is at the discretion of the City Engineer based on the progress of the contract.

Guarantee

Contractor guarantees the Contract work will remain in good condition for the period of one (1) year from the date of completion, ordinary wear excepted. Contractor is financially responsible for any repairs necessary to maintain the Contract work in good condition within one year from completion, ordinary wear excepted.

The determination of the necessity for repairs above mentioned rests entirely with the City Commission whose decision upon the matter shall be final and obligatory upon the Contractor.

If the termination of the said period of one (1) year after the completion and acceptance of the work done under this Contract shall fall within the months of November, December, January, February, March or April, then in that case said months shall not be included in the computation of the said period of one (1)

year, but said period shall be held and understood to terminate on the 15th day of May next thereafter, unless otherwise permitted by the City Commission. It is hereby expressly understood and agreed that the City shall not finally accept the work before the date specified by the City Commission, and that only in case the Contractor shall serve upon the City Commission in writing a notice that they desire the City to accept or reject the work within thirty (30) days after the service of such notice.

Miscellaneous

No work will be done on Sunday except in case of emergency. The City Commission can waive this provision if the Contractor sufficiently establishes an emergency exists.

This Contract with all its forms, plans, profiles, specifications and stipulations shall be binding upon the heirs, executors, administrators or assigns of the said Contractor, and upon the successors or assigns of the City as if each and all of them had been specifically mentioned.

IN WITNESS WHEREOF, the City Commission of the City of Fargo, by its Mayor, has made and executed this Contract on behalf of said City, and has caused the seal of said City to be hereto affixed and the Contractor has hereunto set their hand and seal the day and year first above written.

CITY OF FARGO (a Municipal Corporation)

by \_\_\_\_\_(CITY SEAL)  
Mayor of the City of Fargo

by \_\_\_\_\_(SEAL)  
Contractor

ATTEST:

\_\_\_\_\_  
City Auditor



CONTRACT BOND

KNOW ALL PERSONS BY THESE PRESENTS: That we,

---

(hereinafter called the principal),

---

(hereinafter called the surety), are held firmly bound unto

---

(hereinafter called the owner), in the sum of

\$ \_\_\_\_\_, for the payment whereof the principal and the surety bind themselves, their heirs, executors, administrators, successors and assigns, jointly and severally, firmly by these presents.

WHEREAS, the principal has, by means of a written agreement, dated \_\_\_\_\_, 20 \_\_\_\_\_, entered into a contract with the owner for

\_\_\_\_\_ Improvement District No. \Project No. \_\_\_\_\_ in accordance with plans and specifications, a copy of which agreement is by reference made a part hereof.

NOW, THEREFORE, THE CONDITION OF THIS OBLIGATION IS SUCH, that the principal will and faithfully perform the work bid for in accordance with the terms of and within the time provided for in the contract, and pursuant to the plans and specifications for such work on file in the office of the City Auditor; that they will pay for all labor and material used in such work including all demands of subcontractors; that the principal will pay or cause to be paid all sales and use taxes payable as a result of the performance of the contract, as well as the payment of gasoline and special motor fuel taxes used in the performance of the contract, and all motor vehicle fees required for commercial motor vehicles used in connection with the performance of such contract, and shall pay all state income taxes to the State of North Dakota upon income derived from such work or project, and that in case of a default on the part of the principal in the performance of the work as provided in their contract, the sum named in the bond shall be taken and held to be fixed and liquidated damages in favor of the owner, and that the full amount thereof may be recovered from said principal and their sureties in an action by the owner against them on said bond; that the said principal has made, or will make prior to the commencement of any work by themselves or any subcontractor under such contract, full and true report to the Worker's Compensation Bureau of the payroll expenditures for the employees to be engaged in such work, and that the principal has paid or will pay the premium thereon prior to the commencement of said work.

The term of this bond shall expire when all terms of the contract are fulfilled including, but not limited to, any warranty period, as well as any extensions of time. No suit, action, or proceeding by reason of any default whatever shall be brought on this bond after six (6) years from the date on which the final payment under the contract falls due.

PROVIDED, that any alterations which may be made in the terms of the contract, or in the work to be done under it, or giving by the owner of any extension of time for the performance of the contract, or any other forbearance on the part of either the owner or the principal to the other shall not in any way release the principal and the surety, or either or any of them, their heirs, executors, administrators, successors, or assigns from their liability hereunder, notice to the surety of any such alteration, extension or forbearance being hereby waived.

Signed and sealed this \_\_\_\_\_ day of \_\_\_\_\_, 20 \_\_\_\_.

WITNESSES:

\_\_\_\_\_

By \_\_\_\_\_  
Principal

\_\_\_\_\_

As to Principal

By \_\_\_\_\_  
Attorney-in-Fact

(Acknowledgement by both principal and surety required.)

INDIVIDUAL ACKNOWLEDGEMENT

STATE OF \_\_\_\_\_ )  
 ) ss  
COUNTY OF \_\_\_\_\_ )

On this \_\_\_\_\_ day of \_\_\_\_\_ in the year \_\_\_\_\_ before me,  
\_\_\_\_\_, a Notary Public, personally appeared  
\_\_\_\_\_, known to me (or proved to me on the  
oath of \_\_\_\_\_) to be the person who is described in and who  
executed the within instrument and acknowledged to me that is executed the same.

(SEAL)

\_\_\_\_\_  
Notary Public

CORPORATION ACKNOWLEDGEMENT

STATE OF \_\_\_\_\_ )  
 ) ss  
COUNTY OF \_\_\_\_\_ )

On this \_\_\_\_\_ day of \_\_\_\_\_ in the year \_\_\_\_\_ before me,  
\_\_\_\_\_, a Notary Public, personally appeared  
\_\_\_\_\_, known to me (or proved to me on the  
oath of \_\_\_\_\_) to be the president (or other officer or person) of the  
corporation that is described in and that executed the within instrument, and acknowledged to me that  
such corporation executed the same.

(SEAL)

\_\_\_\_\_  
Notary Public

ACKNOWLEDGEMENT OF SURETY

STATE OF \_\_\_\_\_ )

) ss

COUNTY OF \_\_\_\_\_ )

On this \_\_\_\_\_ day of \_\_\_\_\_ in the year \_\_\_\_\_ before me,

\_\_\_\_\_, a Notary Public, personally appeared

\_\_\_\_\_, known to me (or proved to me on the oath of

\_\_\_\_\_) to be the person who is described in and whose name is subscribed

to the within instrument as the attorney-in-fact of \_\_\_\_\_ and acknowledged

to me that they subscribed the name of \_\_\_\_\_ thereto as surety and their own name as

attorney-in-fact.

(SEAL)

\_\_\_\_\_  
Notary Public

## EXHIBIT "A"

## LIQUIDATED DAMAGES SCHEDULE

Effective January, 2015

ORIGINAL CONTRACT AMOUNT		SUBSTANTIAL COMPLETION PER CALENDAR DAY	FINAL COMPLETION PER CALENDAR DAY
From	To and Including	Daily Charge	Daily Charge
\$ 0	\$50,000	\$350	\$105
50,000	100,000	400	120
100,000	250,000	700	210
250,000	500,000	900	270
500,000	1,000,000	1,200	360
1,000,000	2,000,000	1,600	480
2,000,000	5,000,000	2,500	750
5,000,000	8,000,000	3,000	900
8,000,000	12,000,000	4,000	1,200
12,000,000	Up	5,000	1,500