

# Detached Garages and Accessory Buildings



## CITY OF FARGO BUILDING INSPECTION DEPARTMENT

The State of North Dakota requires that you call [1-800-795-0555](tel:1-800-795-0555) at least two business days before you dig.

This handout does not address any covenants or easements assigned to the property, nor does it relieve you of code compliance with items that may not have been included from the International Residential Code (IRC).



# Table of Contents

Definitions and Requirements.....	4
Lot Coverage and Setbacks .....	5
Location on Property.....	6
Figuring Your Lot Coverage.....	6
Floodplains and Elevations.....	8
Garage Foundations .....	8
Headers .....	8
Wall Bracing at Overhead Doors .....	10
Portal Framing .....	11
Portal Framing Illustration.....	12
Garage Height .....	13
Insulation Requirements .....	14
Frequently Asked Questions.....	14

**Please note:** This booklet contains general rules. Additional rules may apply to specific properties. You can find Information about lot size, easements, and zoning on the City of Fargo web site via the interactive map at <http://gis.cityoffargo.com/Link/jsfe/Public.aspx>.

# Definitions and Requirements

Foundation:	The lowest load-bearing part of a building, typically below ground level. The foundation must be constructed of masonry, concrete, or treated wood.
Garage Floor:	Where motor vehicles are stored, floor surfaces shall be constructed of noncombustible materials.
Lot Coverage:	The percentage of the area of the lot that is allowed to be covered by the main buildings and all accessory buildings within a specified zoning district. Uncovered decks, patios, and stairs do not count toward this total.
Property Line:	A recorded boundary of a plot. It is the owner's responsibility to know where and how to locate the property lines. The City of Fargo assumes that the owner knows this information. Errors due to lack of property line knowledge will cause delays and additional expense.
Required:	Needed; essential; necessary
Yard:	An open space, other than a court, on the same lot with a building.
Yard, Front:	A yard extending across the full width of a lot and having a depth equal to the shortest distance between the front line of the lot and the nearest portion of the main building, including an enclosed or covered porch. Where a building line or other line for designation of future street width has been established, the front yard depth shall be measured from such line instead of from the front line of the lot.
Yard, Rear:	A yard extending across the full width of a lot and having a depth equal to the shortest distance between the rear line of the lot and the main building.
Yard, Side:	A yard between the side line of the lot and the main building extending from the front yard to the rear yard and having a width equal to the shortest distance between said side line and the main building.

# Lot Coverage and Setbacks

## §20-0501 Residential District Standards

The dimensional standards of Table 20-05010 apply to all development in MR-3 and more restrictive zoning districts.

Table 20-0501

Dimensional Standard	Zoning District										
	AG	SR-0	SR-1	SR-2	SR-3	SR-4	SR-5 [9]	MR-1	MR-2	MR-3	UMU
<b>Maximum Density</b> (UPA-Units Per Acre)	0.1	1.0	2.9	5.4	8.7	12.1	14.5	16.0	20.0	24.0[1]	18.0 Min.
<b>Minimum Lot Size</b>											
Area (Sq. Ft.)	10 Ac	1 Ac [2]	15,000	8,000	5,000	3,600	3,000	5,000	5,000	5,000	2,420
Width (Ft.)	200	120	80	60	50 [3]	50 [3]	25	50 [3]	50 [3]	50 [3]	50 [3]
<b>Minimum Setbacks (Ft.)</b>											
Front	50 [4]	50	35	30	20	15 [5]	15 [5]	25	25	25	10
Interior Side [6]	25	25	15/15	10/5	10/5	4	4	15/25	15/25	10	5
Street Side	25 [7]	25	17.5	15	12.5	10	10	12.5	12.5	12.5	10
Rear	50	50	25	25	15	15	15	20	20	20	15
Watercourse Setback	[10]	[10]	[10]	[10]	[10]	[10]	[10]	[10]	[10]	[10]	[10]
<b>Max. Building Coverage</b> (Pct. Of Lot)	NA	25	25	35	40	45	50	35	35	35	75
<b>Minimum Open Space</b> (Pct. Of Lot)	NA	NA	NA	NA	NA	NA	NA	35[8]	35[8]	35[8]	N/A
<b>Maximum Height (Ft.)</b>	35	35	35	35	35	35	35	35	45	60	60

Source: 2985 (1999), 3062 (1999), 4039 (2000), 4668 (2003), 4695 (2009), 4818 (2012).

[1] Higher densities may be allowed with the Bonus Density provisions of Sec. 20-0505.

[2] SR-0 minimum district size is 20 acres. See section 20-0203-A.

[3] Minimum lot width subject to limitation of access as provided in Section 20-0702.

[4] Minimum 100 feet from right-of-way on Arterial or section line road.

[5] Minimum 20-foot setback shall be provided between front-entry garages and nearest edge of sidewalk crossing plate.

[6] #/# = Percent of Lot Width/Feet (whichever is less)

[7] Minimum 75 feet from right-of-way on Arterial or section line road.

[8] Maximum of 37.5 percent of building coverage shall be allowed if site amenity is provided in accordance with Sec. 20-0403.B.7. If the amenity is contained within the footprint of one primary structure, the floor area of that amenity is counted as open space, but is not subtracted from the area of the building.

[9] The SR-5 zoning district is limited to a maximum size of 21,000 square feet, up to a maximum of two acres provided the district is within 600 feet of a private or public dedicated open space feature, such as a public park, private park, school yard or playground that is accessible to residents of the SR-5 district, any of which shall be a minimum of two acres or more in size. For purposes of identifying a single SR-5 zoning district, parcels adjacent to one another that are, or will be, the same zoning classification shall be deemed to be within the same zoning district and, therefore, shall be subject to the maximum size limitation.

[10] Watercourse setbacks for all residential, nonresidential, and overlay/special zoning districts are set forth in Section 20-0508.

# Location on Property

Detached garages and accessory buildings may not be built within three (3) feet of the side or rear lot lines. If there is an easement on your property, you cannot build a permanent structure on that easement. If your property is on a corner you are required to meet the street side setbacks in the table on the previous page.

Overhangs may extend no more than one foot into the required setback. If the structure, including the overhangs, will be within three (3) feet of a residence special fire protection regulations may apply.

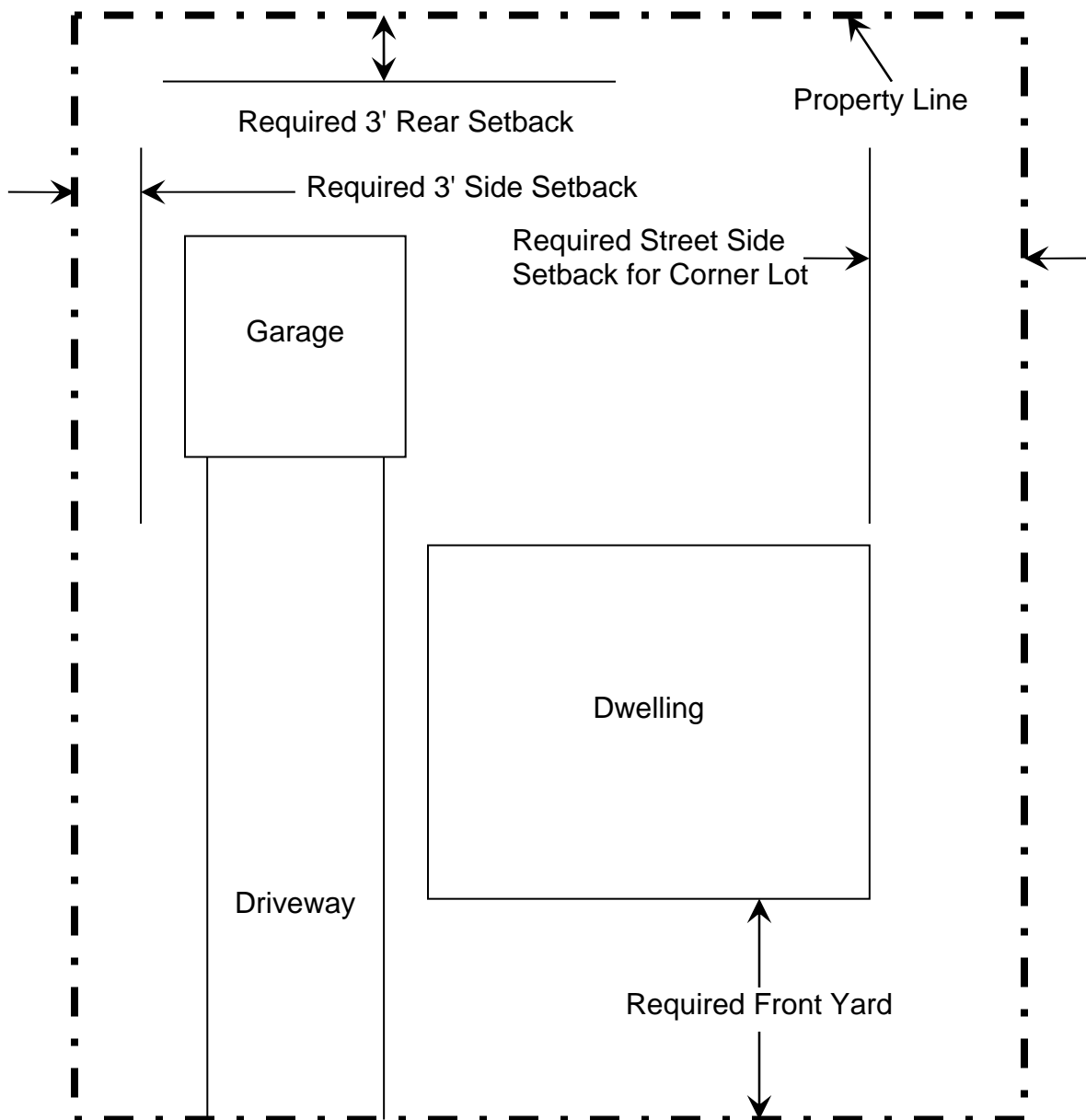

# Figuring Your Lot Coverage

The amount of your lot that you may cover with structures varies depending on zoning. As an example, SR-2 zoning allows 30% lot coverage maximum for all buildings. For a typical lot of 60'x140' (8,400SF) of lot area, 35% of 8,400SF is 2,940SF of lot coverage allowed.

Note that lot coverage only includes the footprint, not the full square footage of a building if there is more than one floor. In no case may the total footprint of the garage or outbuilding be greater than the footprint of the house or 700 square feet, whichever is greater.

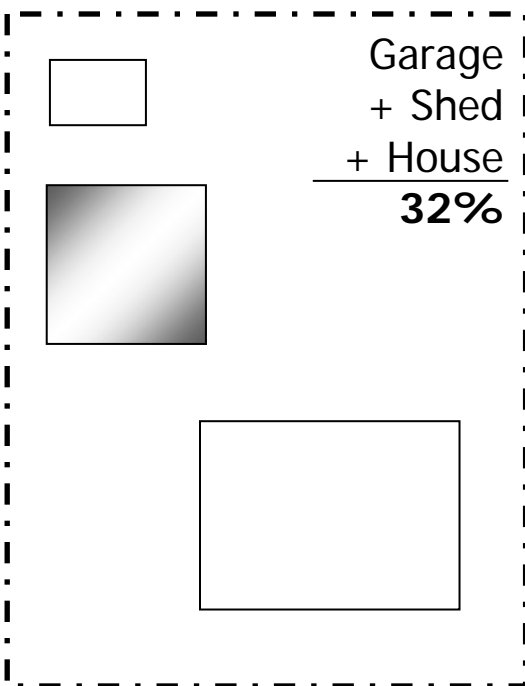

**OK**

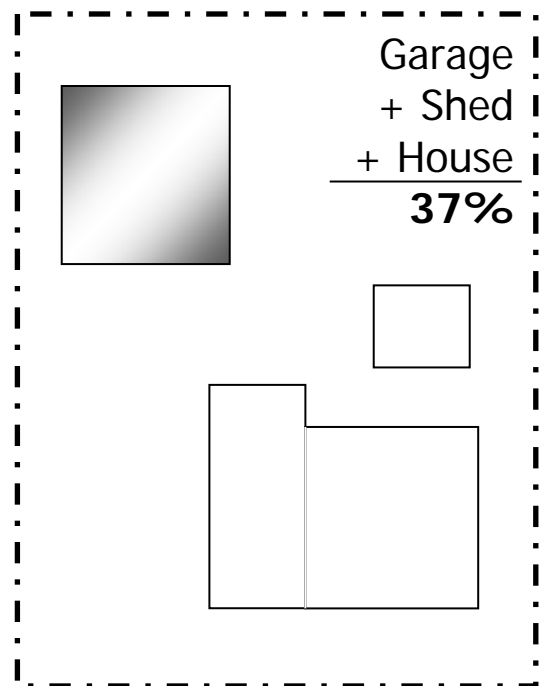

**WRONG**

# Floodplains and Elevations

If your lot falls in the FEMA 1% floodplain, any accessory buildings are required to be elevated to a minimum of one foot above the Base Flood Elevation. You can find this elevation on the City of Fargo web site at <http://gis.cityoffargo.com/Link/jsfe/Public.aspx> by turning on the “Current/Effective FEMA Floodplains” overlay or by visiting the FEMA website at <https://www.fema.gov/faq-details/Creating-FIRMette>. When you apply for a building permit, we will send City staff out to mark the required elevation in the area where you wish to build. The top of your floor must be at or above this elevation.

Should your property fall in the Limited Disturbance Zone Setback (LDZS), you will be restricted to a single outbuilding no larger than 120 square feet. If your property is in the Minimal Disturbance Zone Setback, no additional construction will be allowed.

## Garage Foundations

Garage slabs must extend a minimum of 12” below ground level. Bottom plates or sills (the bottoms of the garage walls) shall be bolted to the foundation or foundation wall with not less than 1/2-inch diameter steel bolts embedded at least 7 inches into the concrete or masonry and spaced not more than 6 feet apart. There shall be a minimum of two bolts per piece of wood with one bolt located within 12 inches of each end of each piece. A properly sized nut and washer shall be tightened on each bolt to the plate.

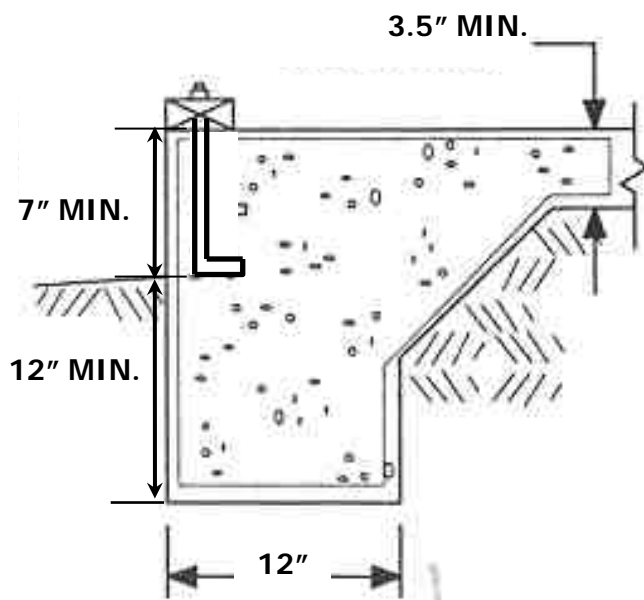



# Headers

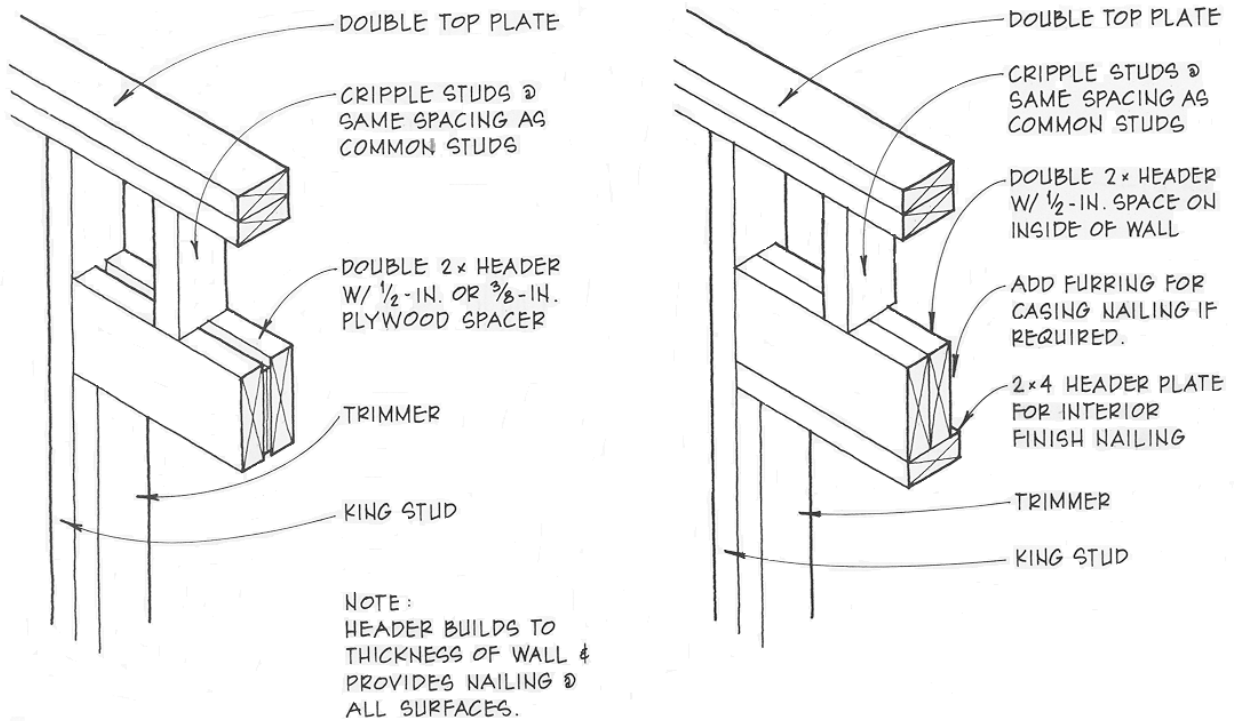
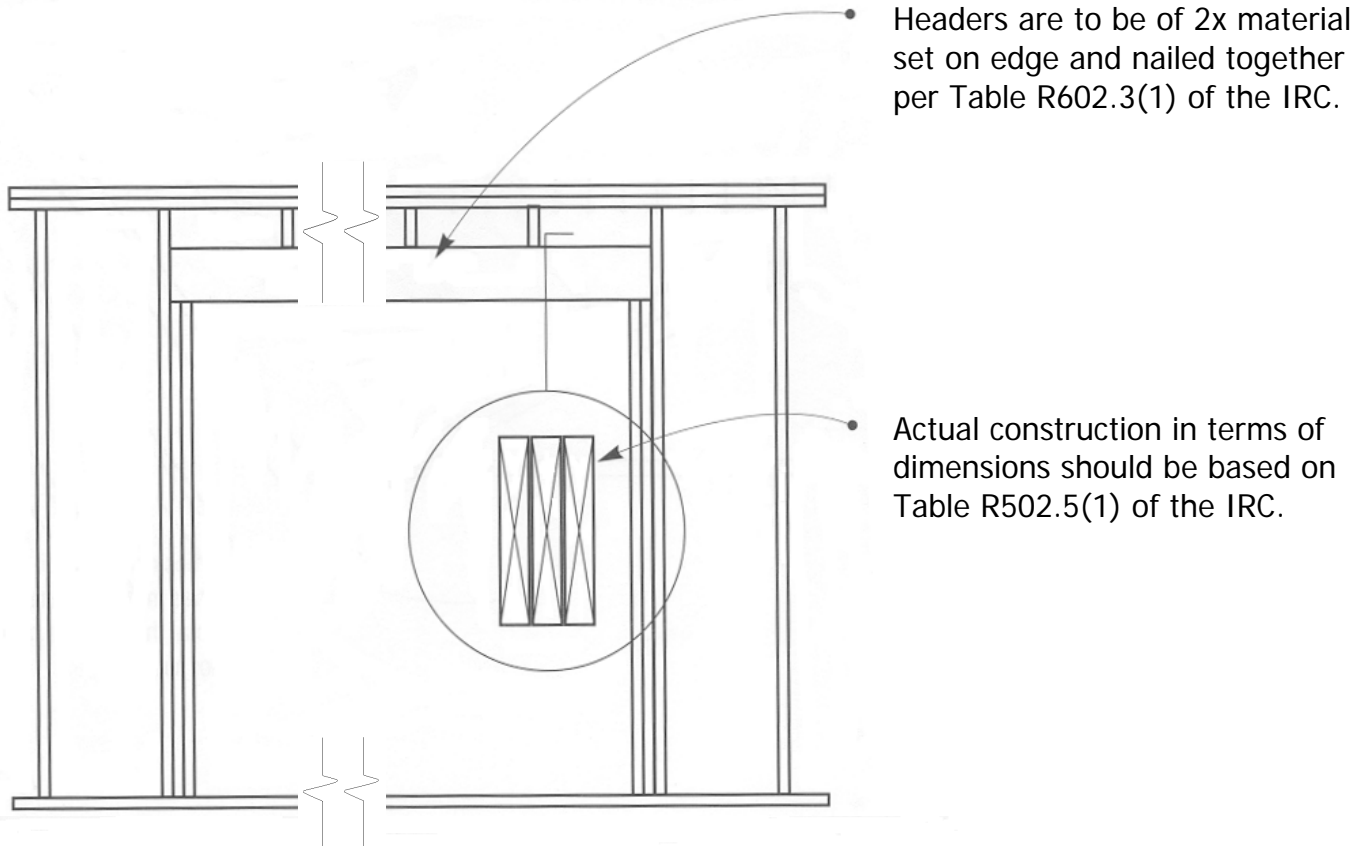

**Figure R602.10.6.2**

# Wall Bracing at Overhead Doors

The table below gives you the minimum length of the solid wall (with no doors or windows) required between the corner and the opening for your garage door. If your garage will not have this much wall this required panel width, you can use portal framing to provide the required braced wall panels for your garage on one or both sides of the overhead door.

The first column shows the height of the overall wall, from the bottom plate to the top plate, which is often higher than the top of the garage door header. The second column shows the required panel width in inches. The ratio for this option is 1 foot to three inches.

Wall Height	Panel Width
13.5'	40.5"
13'	39"
12.5'	37.5"
12'	36"
11.5'	34.5"
11'	33"
10.5'	31.5"
10'	30"
9.5'	28.5"
9'	27"
8.5'	25.5"
8'	24"
7.5'	22.5"
7'	21"

# Portal Framing

The required width of the panel(s) used for portal framing depends on the height of the opening. The first columns of this table shows the measurement from the top of the header over the opening to the top of the bottom plate (the flat piece at the bottom of the wall) and the required panel width in inches. The ratio is 2 inches of wall to one foot of opening height.

<b>Header Height</b>	<b>Panel Width</b>
10'	20"
9.5'	19"
9'	18"
8.5'	17"
8'	16"
7.5'	15"
7'	14"

For portal framing, the header must extend past the opening the full width of the required panel. The sheathing is fastened to this header extension in a 3"x3" grid of 8d galvanized nails. A strap is required on the inside of the garage tying one of the studs below the header to the framing above it. At least two anchor bolts must be installed within the required panel width 2"x2" plate washers rather than the standard round washers. See the following page for an illustration of this bracing method.

# Portal Framing Illustration

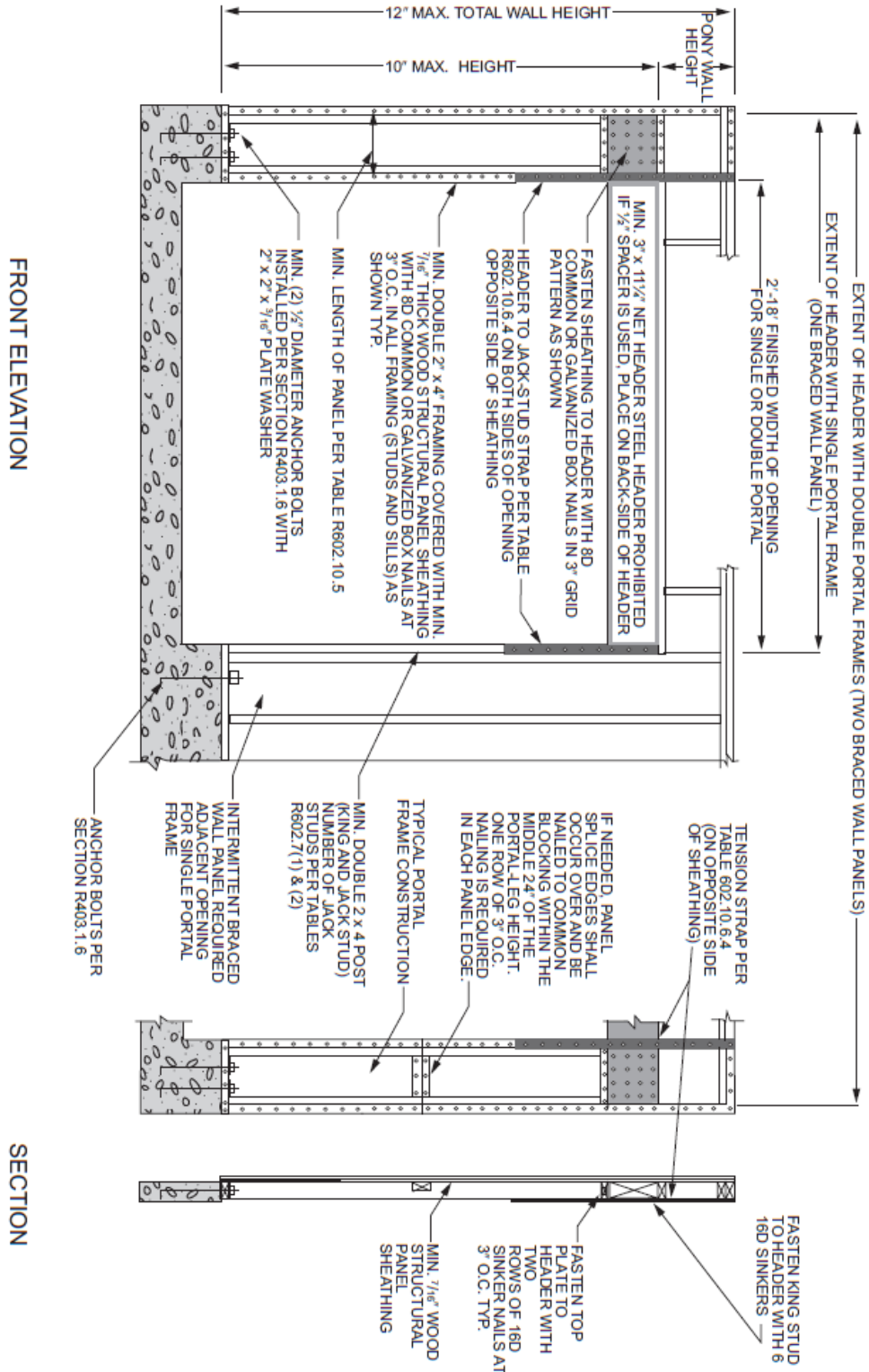

# Garage Height

Garages and sheds may not be more than fifteen (15) feet in height. The height is measured at a point midway between the ridgeline, at the top of the roof, and the lowest point of the roof (the eaves). The height of your walls and the style and pitch of your roof will determine the overall height of the building.

M = Measure the highest (peak) and lowest (at the eaves) points of the roof and average these two numbers

H = Height at the midpoint of those measurements (the average you calculated above), which may not exceed 15'

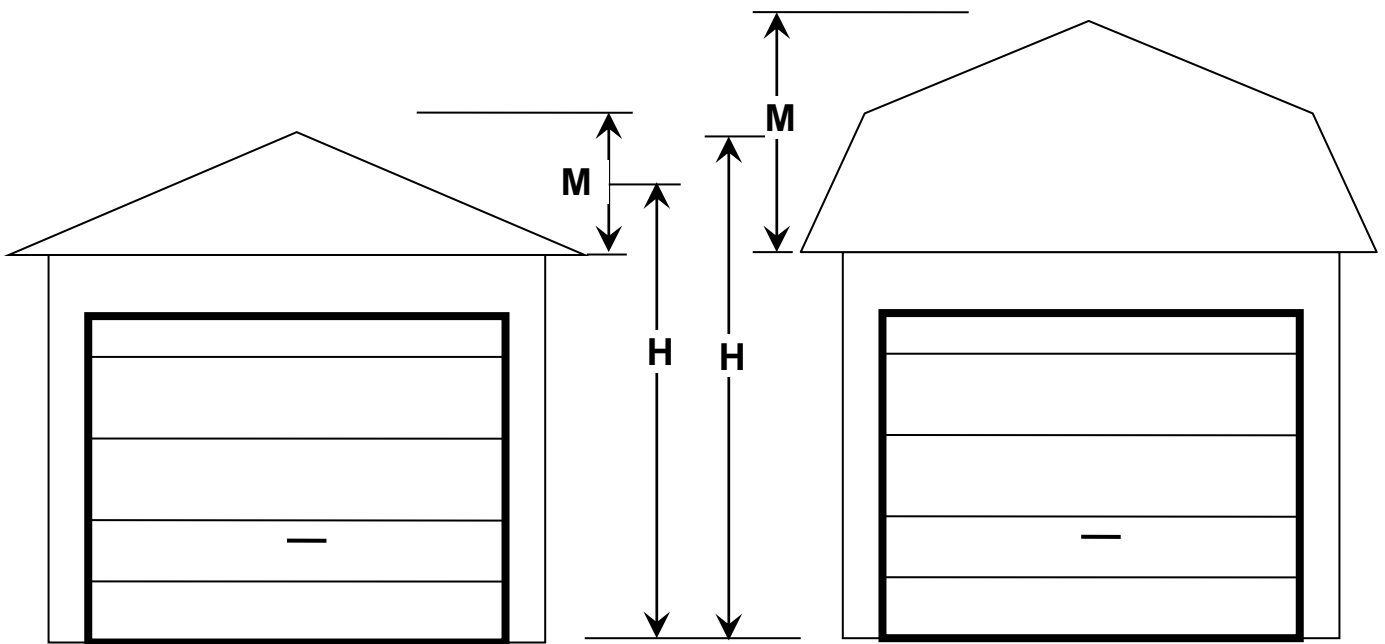

# Insulation Requirements

If you will be providing permanently installed heat in your shed or garage, whether through in-floor tubing or a permanently installed heater, you will also be required to insulate the building and construct a permanent foundation. The walls must be insulated to a minimum R-value of 21 and the ceiling or roof to R-49.

## Frequently Asked Questions

### **IS A BUILDING PERMIT REQUIRED?**

Yes! Before you begin any work you must acquire a building permit.

### **WHY SHOULD I GET A PERMIT?**

To establish a record that your garage/home is constructed to code; to safeguard your property; to protect yourself; and to establish a record of construction or remodeling history on your property.

### **WHAT IS NEEDED TO GET A PERMIT?**

The address and the zoning of the property, the intended use of the property (if uses other than accessory are anticipated), the estimated cost of construction of the project, and a site plan showing the size and location of all existing buildings on your property along with the proposed project. Also, basic construction drawings are often helpful. If you have truss drawings for your new building, bring those as well.

### **HOW LONG DOES IT TAKE TO GET A PERMIT?**

The answer depends upon the information provided and the complexity of the project. For simple accessory building permits, it will typically take approximately 15 minutes. For complex projects or buildings in the floodplain, it may take a couple of days to get all of the paperwork and elevation requirements finalized.

### **ARE INSPECTIONS REQUIRED?**

YES! It is the responsibility of the permit holder to arrange for inspections. This includes a foundation, framing, electrical wiring and heating (should these items be included in your project), and a final inspection. These inspections are a part of the permit process. Building inspections consist of examining and evaluating construction to determine if the work meets the accepted standard of construction. There is no additional charge for inspections.