

**CITY OF FARGO SPECIFICATIONS  
CONCRETE PAVING AND CURBS & GUTTERS**

**PART 1  
DESCRIPTION OF WORK**

The work to be done under this section of the Specifications and the accompanying plans consists of furnishing all labor, material, accessories, and plant necessary to complete the concrete curb and gutter and/or concrete paving of certain streets, avenues or alleys in the City of Fargo.

This item includes excavation, filling, and subgrade preparation in accordance with Section #2000. This item shall also include the furnishing and placing reinforcing steel, curb and gutter, valley gutters, furnishing and setting headers, constructing the type of paving designated, setting castings or valve boxes to grade, and all other work as may be necessary to properly complete the work in accordance with these Specifications and the accompanying plans.

**PART 2**  
**MATERIALS**

2.1. CEMENT

Cement shall meet the current specifications of ASTM. The cement shall be an approved and established brand of Portland Cement Type I or II meeting the requirements of ASTM C-150. Different brands of cement, or the same brand of cement from different mills, shall not be mixed during use without permission of the Engineer. Cement shall be stored in a suitable manner to prevent moisture damage; cement which is partially set or which contains lumps or cakes shall be rejected.

2.2. AGGREGATES

Aggregate for slip-form and alley paving mixes shall generally be provided with gradations considered well-graded by specification as determined by the most current NDDOT Specification for Well-Graded Aggregates for concrete. Optimization techniques will be used to prepare the final aggregate gradations for workability and coarseness factor considerations. Fine and coarse aggregates for all other mixes shall conform to the requirements of ASTM C33 for Concrete Aggregates and meet the following requirements:

A. FINE AGGREGATES:

<u>Sieve Designation (Square Openings)</u>	<u>Percentage by Weight Passing Sieves</u>
3/8 Inch	100%
No. 4	95-100%
No. 16	45-80%
No. 50	10-30%
No. 100	0-10%
No 200	0-3%

The maximum limits of deleterious material shall not exceed the limits stated in ASTM C33-93. Shale content shall be less than 1 %.

## B. COARSE AGGREGATES:

<u>Sieve Designation (Square Openings)</u>	<u>Percentage by Weight Passing Sieves</u>
1 1/2 Inch	100%
1 Inch	95-100%
1/2 Inch	25-65%
3/8 Inch	15-55%
No. 4	0-10%
No. 8	0-5%

The maximum limits of deleterious material shall not exceed the limits stated in ASTM C33-93, Class 4S; the total of all deleterious substances, excluding No. 200 material, shall not exceed 2.3% by weight. Shale content shall be less than 1 %. The aggregate shall show a loss of not more than 35% when tested in accordance with ASTM C131.

Crushed hydraulic cement concrete will not be allowed.

2.3. WATER

Water for concrete shall be clean, free from oil, acid, alkali, and vegetable substances.

2.4. ADMIXTURES*2.4.1. AIR ENTRAINMENT*

An air entrainment admixture or air entrained cement is to be used. Entrained air content shall be targeted for 6% and will be between 5% and 8% as measured at the point of placement. Air entrainment admixtures shall conform to ASTM C-260 standards; air-entraining cement shall conform to ASTM C226.

*2.4.2. ACCELERATORS AND OTHER ADMIXTURES*

A water reducing concrete admixture shall be used in the concrete mix. All admixtures shall meet ASTM C494. Accelerators and water reducing admixtures shall be non-chloride type.

### *2.4.3. FLY ASH*

Fly ash shall meet the requirements of AASHTO M-295 for Portland Cement Concrete. Fly Ash will be allowed as a cement replacement on a 1:1 ratio, up to a maximum of 30% by weight. Fly ash content of mixes will be reduced to a maximum of 20% replacement of cement in cold weather concrete conditions. Cold weather exists when the air temperature has fallen to, or is expected to fall below 40°F (4°C) during the protection period, which is defined as the time required to prevent concrete from being affected by exposure to cold weather. All fast-track concrete mixes will include at least 20% direct replacement of cement with fly ash.

### *2.5. EPOXY RESIN ADHESIVE*

Epoxy resin shall meet or exceed the requirements of AASHTO M235 Type IV, Grade III.

### *2.6. REINFORCEMENT STEEL, DOWELS OR TIE BARS*

#### *2.6.1. PLAIN OR DEFORMED STEEL BARS*

Plain or deformed steel bars shall comply with ASTM A615 or ASTM A616 standards. Bars shall be free of excess rust, scale or other substance that may prevent bonding of the concrete to the reinforcement. All intersections of the longitudinal and transverse bars shall be securely wired, clipped or welded together to prevent displacement during handling and construction operations.

#### *2.6.2. DOWEL AND TIE BARS*

Deformed steel bars meeting the Specifications for bar reinforcement shall be used for the tie bars joining slabs together across longitudinal joints or joining slabs to the curb and gutter section. Dowel bars across transverse joints shall be epoxy coated smooth round bars meeting the Specifications for bar reinforcing. Plate dowels shall be of trapezoidal shape and epoxy coated. All dowels shall be greased or coated for debonding as indicated below. All tie bars used for the longitudinal joints or joining slabs to the curb and gutter section shall be epoxy coated and meet the requirements of AASHTO M-284. The epoxy coating shall be in accordance with AASHTO M284/M.

All epoxy coated bars shall be protected from the sun's rays with tarps or other means if they are to be subjected to the sun's rays for more than 180 days. Exposure for periods

longer than 180 days will result in the product being rejected from use on City projects. Bars carried over as excess from previous year's construction shall not be used on any project unless documentation of protection from the sun is given to the Engineer. Bars showing rust through the coating shall be rejected for use on a project. Epoxy coatings shall be 8 to 12 mils in thickness.

Bondbreaker coatings of dowel bars shall include any effective coatings as approved by the NDDOT, and may include Contractor applied grease or form oil spray applications and factory applied Tectyl-506.

## 2.7. JOINT MATERIAL

### *2.7.1. EXPANSION JOINTS*

If expansion or isolation joints will be required, they shall be as indicated in the diagrams. Expansion/Isolation joint material shall conform to ASTM D-1751. Joint material shall be 1-inch in thickness, 1/2 inch less in height than the pavement depth. It shall extend the full width of the pavement slab and curb, and any concrete at the ends when the forms are removed shall be chipped away. The dowel support shall securely and rigidly hold the dowel bars and premolded filler in correct position during the paving operation. All expansion/Isolation joint faces shall be cleaned by sandblasting and sealed with silicone sealant to produce a slightly concave surface approximately 1/4 inch below the concrete surface.

The expansion joint dowel bar assembly shall be of a type as manufactured by Dayton Superior, Wady Industries, Construction Materials, Inc., Laclede Steel Company, the Bethlehem Steel Company, the American Steel and Wire Company, or approved equal. The entire expansion joint assembly shall be of a type approved by the Engineer.

### *2.7.2. POURED JOINT FILLER*

The material for filling poured expansion and contraction joints and cracks shall be hot poured elastic type and shall conform to the requirements of ASTM D-6690. The material shall be composed of a homogeneous blend of virgin polymers, plasticizers, special fillers and asphalt compounded specifically for the sealing of cracks in asphalt or concrete pavement. Ground cured rubber scrap shall not be used. Meadows Safe-Seal 3405 is an approved substitute for the hot pour material.

*2.7.3. SILICONE JOINT SEALANT*

The sealant shall be a Low Modulus Silicone Sealant meeting the requirements of the NDDOT Specifications, Section 826.02.B.1. Self-leveling silicone sealants will not be allowed.

2.8. CURING COMPOUNDS

All curing compounds shall be applied in accordance with the manufacturer's recommendations.

*2.8.1. MAINLINE (INCLUDING CURB & GUTTER SECTION) AND ALLEY PAVING*

Linseed oil based or poly-alpha-methylstyrene liquid curing compound, white pigmented conforming to the requirements of AASHTO M 148 Type 2, Class B.

*2.8.2. CURB & GUTTER ADJOINING ASPHALT PAVEMENT*

White pigmented conforming to the requirements of AASHTO M 148 Type 2.

2.9. PROPORTIONS

One cubic yard of mixed concrete in place shall contain not less than 564 lbs. minimum of cementitious materials. The water-cement ratio shall not exceed 0.40 for slip-formed pavement and 0.42 for hand-placed pavement mix. The slump shall not exceed four (4) inches. Minimum 28-day compressive strength shall be 4,000 p.s.i. Entrained air content shall be targeted for 6% and will be between 5% and 8%.

Mixes shall use optimized aggregate proportioning to meet well-graded mix specifications of the NDDOT for all slip-form concrete pavements. Hand-placed concrete pavements shall also have optimized aggregate gradations or meet NDDOT AE-3 mix criteria.

2.10. FAST-TRACK CONCRETE

When Fast-track Concrete Mixes are specified, the Contractor shall use the following criteria:

1. Cements will be Type I or II with a maximum of 564 lbs. total cementitious content including a minimum of 20% replacement of cement with fly ash. Water-cement ratios will be as limited above in Section 2.8.

2. Fast-track mixes will have optimized aggregate, will use non-chloride accelerators for early strength, and may use hydration stabilizers to preserve workability en-route to the project.
3. Contractor shall provide environment to ensure that mixes will attain a field strength of either 400 psi flexural strength or 2500 psi compressive strength in 24 hours. At no time may concrete exceed 150° F in temperature while under blankets or other protection devices, nor fall below 60° F during the 24 hour period.

#### 2.11. PLANT CERTIFICATION

All plants supplying concrete to a paving project shall be certified by an approved plant certification program including that provided by the National Ready Mix Concrete Association, MNDOT or NDDOT in the current construction season.)

#### 2.12. MIXING

Concrete shall be mixed in a rotary batch mixer of a type acceptable to the Engineer. The volume of the mixed material for each batch shall not exceed the manufacturers rated capacity of the mixer. The batch material shall be delivered to the mixer accurately measured to the desired proportions and shall be continuously mixed for not less than one and one-half minutes after all materials including water are in the mixer, during which time the mixer shall rotate at the speed recommended by its manufacturer.

In lieu of job-site or batch mixing, ready-mixed concrete, meeting the requirements specified herein and all applicable requirements of ASTM C94 may be used. The size of the batch shall not exceed the manufacturer's rated capacity as shown on a metal rating plate that shall be attached in a prominent place on the truck mixer. When mixing, the drum shall rotate at a mixing speed for not less than 60 revolutions and not more than 300 revolutions. The drum shall be completely emptied before receiving the material for the succeeding batch.

The concrete shall be completely discharged within 90 minutes after the introduction of the mixing water to the dry materials when ambient temperatures are less than or equal to 80 degrees. This time is reduced to 60 minutes when temperatures exceed 80°F. Mix temperatures between batching and placement shall not exceed 90 degrees F. Observations and adjustments to slump shall be made at the time of preparation for dumping. Once dumping of mix is started, retempering of mortar or concrete is not allowed.

### 2.13. FORMS

Forms shall be metal, made of shaped steel, with sections that interlock and are at least 10 feet in length. The forms shall be of the same thickness as the concrete to be placed against them and shall have a base width of at least 2/3 their height. They shall have at least 3 stake pockets for every 10 feet of length and the bracing and support must be able to withstand the pressure of the concrete and weight and thrust of the machinery operating on the forms. Forms shall be set upon the compacted subgrade at to exact line and grade for a distance of at least 300 feet in advance of the concrete placing operation. Metal forms shall be oiled or coated with soft soap or whitewash before depositing the concrete against them. Forms shall be mortar and dirt free and shall be checked with a 10-foot straightedge and any variation in excess of 1/8 inch shall be corrected.

Approved flexible or curved forms of proper radius shall be used on curves having a radius 150 feet or less. Straight forms longer than 10 feet shall not be used on any curved line unless approved by the Engineer.

If the pavement is being placed contiguous to previously finished pavement or curb and gutter, such finished pavement or curb and gutter may be made to serve as a side form if found to be suitable in the opinion of the Engineer.

### 2.14. SLIPFORM PAVING EQUIPMENT

All equipment shall be self propelled, and designed for the specific purpose of placing, consolidating, and finishing the concrete pavement to grade and cross-section in one complete pass without the use of side forms. The paver shall vibrate or tamp the concrete for the full width and depth of the layer being placed.

### 2.15. CONCRETE FINISHING MACHINES

The finishing machine shall be adjustable to the specified crown and elevation to maintain the required cover over the reinforcing steel. The machines shall be capable of striking-off and finishing the concrete and compaction shall either be done by the same machine or in a separate operation. The screed shall extend the full width of the slab. All finishing equipment shall be kept in good repair and their use subject to the approval of the Engineer.



2.16. AUXILIARY FINISHING EQUIPMENT AND MATERIAL

The Contractor shall provide the following auxiliary equipment:

- A. *FOOTBRIDGE*  
A footbridge shall be provided so designed that it can be readily transported from place to place and span the width of the slab.
- B. *STRAIGHT EDGE*  
Two or more ten (10) foot straight edges of an approved type shall be used. Extra blades shall be provided and used when previously used edges become wavy and warped.
- C. *FLOATS*  
Approved long-handled floats, each having a blade at least 3 feet in length and 6 inches in width.
- D. *MASTER STRAIGHT-EDGE*  
All straight edges shall be tested by the master straightedge before being used and frequently during their use.
- E. *BROOMS*  
Brooms shall be of an approved push type not less than 18 inches long, from good quality bass or bassine fiber not more than five (5) inches in length. The handle shall be at least one foot longer than one-half the pavement width and shall be readily adjustable.

2.17. SUBMITTALS

At the Engineer's discretion, the Contractor may be required to submit representative samples of the materials he proposes to use prior to the delivery of the materials to the site of the work.

On all projects, the Contractor shall provide the following to the Engineer at least 7 days prior to beginning any concrete placement or paving operations:

- A. *PROJECT MIX DESIGN*  
The Contractor shall develop a trial mix design.

*B. FLY ASH CERTIFICATION*

An original certificate of compliance showing the following information:

1. Project number and name of Contractor
2. Fly ash source by name of company and location of plant
3. Quantity of fly ash in shipment
4. Date of shipment
5. Statement that fly ash meets all requirements of the Specifications

*C. JOINT FILLER/SEALER CERTIFICATE OF COMPLIANCE*

The type of backer rod shall be shown, along with an original certificate of compliance showing the following information for each type of joint filler/sealer to be used on a project, as applicable:

1. Project number and name of Contractor
2. Name of the manufacturer and type of joint filler/sealer
3. The manufacturer's batch and lot number
4. The trade name of the material
5. The weight, pouring temperature, and safe heating temperature
6. Statement that materials meet all requirements of the Specifications

*D. CURING COMPOUND CERTIFICATE OF COMPLIANCE*

An original certificate of compliance showing the following information:

1. Project number and name of Contractor
2. Name of the manufacturer and type curing compound
3. The trade name of the material
4. Statement that materials meet all requirements of the Specifications

**PART 3**  
**CONSTRUCTION**

3.1. EXCAVATION AND SUBGRADE PREPARATION

Excavation and subgrade preparation shall meet the requirements of Section #2000.

3.2. PLACING REINFORCEMENT

Reinforcement, when specified, shall be installed according to the details as shown in the typical section. Reinforcement rod shall be overlapped a minimum of 40 diameters and securely tied. The reinforcement shall be positioned on approved supports or it may be inserted in the plastic concrete by approved mechanical devices after the concrete has been spread, struck off, and consolidated to its full depth.

Dowel bars, when specified, shall be placed in close alignment, both horizontally and vertically, with the direction of the anticipated thermal movement of the slab. Tolerance for horizontal and vertical rotational alignment: 1/8 inch per foot. Tolerance for longitudinal shift: 1.5". Tolerance for vertical placement: 1/4" above, 1/2" below height specified in Chart 1 shown on the Transverse Contraction Joints Detail, except for 7" pavement which shall be mid-slab.

When drilling holes for placement of dowel bars and tie bars, an epoxy resin adhesive shall be used to anchor the bars in the drilled hole. The diameter of the drilled hole shall be as recommended by the epoxy manufacturer. In the absence of recommendations from the manufacturer, holes shall be drilled 1/8 to 1/4 inch larger than the diameter of the dowel bars and tie bars. The drilled holes shall be blown out with compressed air using a device that will reach to the back of the hole to ensure all debris and/or loose material is removed prior to epoxy injection.

Prior to insertion of the bars, drilled holes shall be filled with epoxy resin 1/3 to 1/2 full, or as recommended by the manufacturer. Each bar shall be rotated during installation to eliminate voids and to ensure complete bonding occurs. Bar insertion by the dipping method will not be allowed.

3.3. PLACING CONCRETE

All concrete shall be placed with formwork unless placed by a curb machine or mechanical paver. Curb and gutter may be installed integral with the concrete pavement except at curb radii and one full panel height on each side of inlet castings not located in a radius, where it shall be installed separate. After mixing, the concrete shall be handled rapidly and the successive batches deposited

in a continuous operation until individual sections are completed. The concrete shall be placed so segregation and unnecessary rehandling is avoided. Immediately prior to placing the concrete, the inside of the forms shall be wetted and the aggregate base moistened with water. The forms shall be filled and concrete brought to the established grade. Trucks hauling concrete shall not back over reinforcing or over previously deposited concrete. Ruts exceeding ½ inch in depth shall be filled with granular material prior to the placing of concrete. Concrete shall not be placed on a frozen subgrade or base.

The mixed concrete shall be deposited on the subgrade to the required depth and for a width not exceeding the direct reach of the mixer boom, in successive batches and in a continuous operation without the use of intermediate forms or bulkheads between joints. If concrete placement is temporarily interrupted, the unfinished face of the concrete shall be covered with wet burlap or plastic sheeting. When placement operations are resumed, the concrete shall be broken down and thoroughly consolidated with the fresh concrete. If the elapsed time between placement loads of concrete exceeds 45 minutes, a transverse construction joint shall be installed. While being placed, the concrete shall be vibrated with spud type vibrators or a vibrating screed so that the formation of voids or honeycomb is prevented. The concrete shall be especially well vibrated against the forms and along fixed structures.

### *3.3.1. COLD WEATHER POURING*

Concrete shall not be deposited when it appears likely that the air temperature may fall below 35° F during the pouring or within 24 hours unless preparations are made and precautions taken to prevent any damage to the concrete from the low temperature. Any concrete damaged by freezing shall be replaced by the Contractor at his own expense. Temperature of the concrete when deposited in the forms shall be between 55° and 90 ° F and maintained at a minimum of 40° F for at least 5 days after placing, or until the concrete attains a compressive strength of 3000 psi. If the temperature is expected to drop below 35° F, prior to placement of concrete, the Contractor shall submit a detailed plan of how the concrete's temperature will be maintained above 40° F. Concrete shall not be placed on a frozen subgrade or base.

A calcium chloride admixture shall not be used. Non-chloride accelerators shall be used. Accelerators will not be considered as an "anti-freeze agent".

### 3.4. JOINTS AND SAWING

Joints in concrete pavement shall be of the design specified and shall be constructed at the spacing and locations shown on the plans. Where a specific jointing layout is not provided, jointing shall be per the standard detail in these Specifications. The contractor shall establish the joint locations in the field from the plans or standard details. All joints shall be sawed along a true and straight line established by the Contractor and shall not deviate at any point by more than 1/2 inch from the established line.

#### *3.4.1. TRANSVERSE CONTRACTION JOINTS AND SAWING*

The location of each transverse joint shall be marked in a manner satisfactory to the Engineer, prior to placement of the concrete and, in the case of joints that are to be sawed, the markings shall be transferred to the fresh concrete as soon as the final finishing operations have been completed. All contraction joints shall be sawed to a sufficient depth to control cracking, but in no case to a depth less than 1/4 of the thickness of the pavement plus 1/4 inch. Transverse joints constructed in the pavement shall be extended through the integral or separate curb. The Contractor shall be responsible for sawing to a depth that will prevent uncontrolled cracking. A sufficient number of saw cuts shall be made as soon as possible to relieve the contraction joint tension in the slab. Remaining saw cuts must be made within 48 hours after pouring.

The initial sawing shall be accomplished as soon as the condition of the concrete will permit without raveling and before random cracking occurs. The sequence of initial sawing shall be at the Contractor's option. The sawing shall be immediately delayed if any raveling occurs. Water under nozzle pressure shall be used to remove the sawing residue from each joint and the pavement surface immediately after completing the sawing of that joint. Widening of the joints to full width as per dimensions shown on the jointing/sealing detail shall not be performed until the concrete has cured for at least 24 hours and shall be delayed longer when the sawing causes joint raveling.

The early entry dry saw "Soff-Cut" method of sawing will only be allowed with the Engineer's approval for the initial saw-cutting. Concrete pavement in which uncontrolled cracks occur shall be removed and replaced at the Contractor's expense. The work shall include the complete removal and replacement of a quantity of pavement, to include dowel bar assemblies when applicable, as is determined necessary for acceptance of the pavement by the Engineer. Any/all damage occurring during the removal and replacement process shall be restored at the Contractor's expense (including but not

limited to base or subgrade). All removal and replacement work shall be in accordance with the requirements of these Specifications.

#### *3.4.2. TRANSVERSE EXPANSION JOINTS*

Expansion joints shall be spaced as shown on the plans and shall be of the preformed type and shall extend entirely through the depth and width of the pavement and through all integral curbs. No concrete shall be left above the expansion material or across the joint, but shall be cut away after the forms are removed.

Dowel bars shall be installed for load transfer across the joint. They shall be held in place midway across the joint, parallel to both the surface and the centerline of the slab by an approved supporting device. The “free” end of the dowel shall be coated with an approved lubricant and covered with an approved metal or plastic dowel cap or sleeve. The preformed filler material shall be accurately pre-punched to fit snugly around the dowel bars.

The expansion material and dowel assembly shall be accurately and firmly staked to the subgrade. The top edge of the filler shall be set 1/2 inch below the pavement surface. During the placing of the concrete, the top edge of the filler shall be protected by a removable channel cap. After the concrete has been placed and finished, the cap shall be removed and the joint edged to the specified radius. All expansion/Isolation joints shall be cleaned by sandblasting and sealed with silicone sealant to produce a slightly concave surface approximately 1/4 inch below the concrete surface.

Before the pavement is opened to traffic, the joint shall be cleaned so that there is a clear space of the specified width for the full depth and width of the pavement. It shall then be filled with joint filler which when cooled shall become flush with the surface of the pavement. Any sealant material on the surface of the pavement shall be removed at the Contractor’s expense.

#### *3.4.3. TRANSVERSE CONSTRUCTION JOINTS*

Transverse construction joints shall be constructed whenever the placing of the concrete is suspended for more than 45 minutes. When the work is suspended near the proper location for an expansion joint, the expansion joint shall be installed in the manner previously specified, except that the concrete shall only be placed on one side of the header, when work is resumed it shall be placed on the other side.

When work is suspended at other locations, a contraction joint shall be formed by securely staking in place at right angles to the subgrade and centerline of the pavement, a bulkhead of wood or metal cut to the cross-section of the pavement and then depositing concrete against it. Before the work is resumed, the bulkhead shall be removed and concrete placed against the face of the older concrete.

Transverse construction joints shall only be constructed at planned transverse joint locations.

Dowel bars shall be installed for load transfer across the joint. The Dowel bars shall be either installed with the construction joint or later drilled in place. If installed with construction joint they shall be held in place midway across the joint, parallel to both the surface and the centerline of the slab by a dowel splicer basket assembly, self supported dowel sleeve, or other supporting device approved by the Engineer. The dowel bars shall be installed within the tolerances specified above for placing reinforcement. One end of the dowel shall be painted or coated with an approved lubricant.

#### *3.4.4. LONGITUDINAL JOINTS*

The longitudinal joint between adjoining, separately constructed pavement shall be as constructed as shown on the plans. Tie bars shall be as shown in the detail and may be bent at right angles against the form of the first lane constructed and straightened into final position before the adjacent concrete is placed. Bars may be placed or inserted through small accurately positioned holes or by other approved methods. Tie bars or tie bar baskets shall be placed so that they are not within 12 inches of the intersection of the longitudinal joint and the transverse joint.

If uncontrolled cracking occurs, the concrete pavement shall be completely removed to the nearest planned longitudinal and transverse joints. The removal and replacement method shall be approved by Engineer and at the Contractor's sole expense.

#### 3.5. PAVEMENT FINISHING

Strike-off and compaction shall be done by both vibrating and screeding processes. Separate power machines may be used for each process or both processes may be combined in the same machine, provided controls exist enabling the operator to apply either operation separately or both combined.

When weather conditions cause rapid drying of the pavement surface a fine mist or fog spray applied to the concrete surface shall be permitted only if approved by the Engineer – using any other method to apply water to the concrete surface will not be permitted and will result in non-payment, replacement, and/or repair of the wetted area as determined by the Engineer.

A. Formwork

Forms shall be left in place for at least 15 hours after placing the concrete, and the method of removing them shall not damage or mar the concrete.

B. Straight Edge

The finished surface of the pavement must conform to the grade, alignment, and contour shown on the plans. Immediately following the floating operation, the Contractor shall test the slab surface for trueness with a 10-foot straightedge. The straightedge shall be placed parallel to the pavement centerline and be passed over the slab to reveal any high areas or depressions. The high areas or depressions shall be cut or filled as necessary with the long handled floats and the area checked again with the straightedge. Successive advances of the straightedge shall overlap by 1/2 the length of the straightedge. The entire surface shall be checked until all variations in excess of 1/8 inch in 10 feet have been eliminated. Special care shall be taken at all headers to ensure this variation is held to a minimum.

### 3.6. CURB FINISHING

No grout shall be used to finish the curb. After the concrete is poured into the forms, it shall be puddled and spaded so as to ensure a through, dense mixture, eliminate air pockets, and create uniform and smooth sides.

When weather conditions cause rapid drying of the pavement surface a fine mist or fog spray applied to the concrete surface shall be permitted only if approved by the Engineer – using any other method to apply water to the concrete surface will not be permitted and will result in non-payment, replacement, and/or repair of the wetted area as determined by the Engineer.

Before the curb concrete has thoroughly set, and while the concrete is still green, the forms shall be removed and the front and top side finished with a float or steel trowel to make a uniform finished surface.



## A. ROUNDING CORNERS

Whenever corners are to be rounded, special steel trowels shall be used while the concrete is still workable and the corners constructed to the dimensions herein specified. For combined curb and gutter, the top and side of the curb and gutter may be finished by means of a special shaped trowel or by a curb-and-gutter machine which shapes the entire surface in accordance with the specified dimensions. This trowel shall be used immediately upon removing the front form while the concrete is still workable but firm enough to stand up.

## B. SMOOTHNESS

The top and face of the curb and also the top of the apron on combined curb and gutter must be finished true to line and grade without any irregularities of surface noticeable to the eye. The gutter shall not hold water to a depth of more than 1/4 inch, nor shall any portion of the surface or face of the curb or gutter section depart from more than 1/4 of an inch from a straight edge ten (10) feet in length, placed on the curb parallel to the center line of the street not shall any part of the exposed surface present a wavy appearance.

3.7. FINAL SURFACE FINISH

The edges of the pavement shall be left smooth and true to line, and finished, at about the time the concrete takes its initial set.

After surface irregularities have been removed and before the concrete attains an initial set, the pavement shall be uniformly textured using a seamless strip of artificial grass, or by brooming.

Artificial grass drags or a broom pulled longitudinally in a line parallel to the slab centerline, shall be the texturing method, and shall be maintained in good repair. The texturing material shall apply a uniform texture with 1/16 to 1/8 inch deep striations. The width of the texturing material shall be in full contact over the full width of the pavement. The texturing material shall be cleaned as often as necessary to remove hardened particles or debris that would otherwise scar the surface.

The texturing material being pulled longitudinally shall be mounted to a self-propelled bridge, operated off of the paving string-line, and shall not deviate at any point by more than 1/2 inch from the established alignment.

With formed paving only, brooms shall be drawn across the surface at right angles to the centerline of the pavement, with the stroke of the broom slightly overlapping adjacent strokes. The brooming operation shall apply a uniform texture with 1/16 to 1/8 inch deep striations. Brooms shall be washed and dried at frequent intervals during the day. Any long or coarse bristles that may cause surface irregularities shall be trimmed or cut out, and any brooms that have become worn out shall be discarded.

Upon completion of the final finishing the surface texture shall be uniform in appearance and free of surface water, rough or porous spots, irregularities, depressions, and other objectionable features.

### 3.8. CURING AND PROTECTION

Normal Pavement: As soon as the concrete has been textured, the Contractor shall start curing operations. The finished surface shall be sprayed with an approved curing agent on all exposed faces. Sufficient curing compound shall be applied at a rate of approximately 200 SF/gal to ensure a coating as white as a sheet of paper. In lieu of curing agent, the concrete may be cured by wet burlap or other methods approved by the Engineer. When wet burlap or plastic film is used for curing, the curing period shall be at least 5 days. The concrete surface must not be pitted from or damaged from application of water or incidental rain. The Contractor shall protect all concrete from weather conditions, traffic damage, or any other causes occurring prior to its final acceptance. Any damaged section shall be repaired at the Contractor's expense.

Colored Pavement: Colored pavement shall be cured with an approved clear curing compound generally defined as a dissipating cure or a wax based cure matching the color of the decorative concrete. Curing procedures should generally follow the guidelines of the color admixture supplier for the concrete in the pavement.

Timing of Curing Compound Application: Curing procedures should be undertaken within ½ hour of completion of finishing operations or before the wet sheen on the surface of the concrete disappears, whichever occurs first. Evaporation retarders shall be used for interim protection whenever hot, windy or dry conditions quantified by evaporation rates exceeding 0.2 pounds per square foot per hour exist, and shall be used in accordance with manufacturer's recommendations. Evaporation retarders shall not be used as a finishing aid.

3.9. JOINT FILLING AND SEALING

The Contractor shall not seal joints until they have been inspected and approved by the Engineer. Failure to comply will result in complete removal of the filler/sealer material to allow inspection by the Engineer, at the Contractor's sole expense.

All vertical joint faces shall be cleaned by sandblasting. Oil, asphalt, curing compound, paint, rust, and other foreign materials shall be completely removed. Just before the joints are sealed, the Contractor shall clean the joints with compressed air at a working pressure of at least 90 psi. The joints shall not be sealed when the air temperature is below 40°F.

Backer rod shall be used in all joints to control the depth of the filler/sealer material, achieve the desired shape of the material, and support the material against indentation and sag. The backer rod shall be compatible with the filler/sealer and not subject to the absorption of water. Any joints filled above the specified level shall be corrected by removing and replacing the filler/sealer at the Contractor's sole expense.

Transverse joints constructed in the pavement shall be widened and sealed through the integral or separate curb.

A. HOT POUR

The joint filler shall be forced into the joint with a pressure type applicator capable of filling the joint from the bottom up to a height approximately ¼ inch below the pavement surface, without any overflow or spillage onto the pavement surface. Any excess filler spilled on the pavement surfaces shall be removed at the Contractor's sole expense.

B. SILICONE

Silicone joint sealer may be used in lieu of hot pour elastic filler. The sealant shall be tooled to produce a slightly concave surface approximately ¼ inch below the pavement surface. Self-leveling sealant will not be allowed.

3.10. PROTECTION OF PAVEMENT

The newly-placed concrete shall be protected from traffic by employing watch persons, if necessary, and by the erection and maintenance of barricades, fences, warning signs and lights, pavement bridges, and cross-overs.

When the temperature is expected to fall below 35°F, suitable measures shall be taken to maintain the concrete surface temperature above 40°F for 5 days or until the concrete attains a compressive strength of 3,000 psi. Admixtures for curing or temperature control shall be used only as permitted or directed. The admixtures shall not be considered as a substitute for any specified curing requirement.

Any concrete pavement damaged before final acceptance, including damage by frost action, shall be repaired to the satisfaction of the Engineer or removed and replaced at the Contractor's sole expense.

When bituminous pavement or colored concrete is placed adjacent to PCC pavement, the adjacent PCC pavement shall be protected from spills and smears. Discolored PCC pavement shall be cleaned at the Contractor's sole expense. The PCC pavement shall not be used to stockpile or mix any material unless approved by the Engineer.

### 3.11. PAVEMENT ROUGHNESS AND RIDE QUALITY

This section describes the methods for locating areas of localized roughness, determining the roughness, and provisions for payment and corrective action.

#### A. GENERAL

Except for alley paving, pavement roughness shall be determined and reported in 0.1 mile segments using a profiler on all traffic lanes, including intersections, roundabouts, tapered sections, and turn lane widening segments. Profiles shall be measured by the Contractor in each wheel path per lane and shall be reported as inches/mile in International Roughness Index (IRI) in graph and tabular formats.

Intersections, roundabouts, tapered sections, and turn lane widening segments will not be included in pay deduction calculations. In these areas, only the areas of localized roughness having high points with deviations in excess of 0.3 inches in 25 feet or less will be required to be corrected.

#### B. PROFILER

The Contractor shall furnish a lightweight non-contact profile-measuring device/vehicle capable of measuring IRI in dual wheel paths using a line laser.

The Contractor shall furnish proof of profiler calibration to the Engineer prior to performing profiling operations.

C. MEASURING ROUGHNESS USING A 10' STRAIGHTEDGE

Where directed by the Engineer, pavement shall be measured for roughness using a 10' straightedge and shall meet the following tolerances:

High spots of more than  $\frac{1}{4}$  inch but not exceeding  $\frac{5}{8}$  inch in 10 feet shall be ground with diamond grinding equipment to an elevation where the deviation is less than  $\frac{1}{4}$  inch. When the deviation exceeds  $\frac{5}{8}$  inch, the area shall be ground with diamond grinding equipment to the specified  $\frac{1}{4}$  inch deviation or the pavement shall be removed and replaced at the Contractor's expense. The Contractor shall repair the area as directed by the Engineer, including installing dowel bars at each end of the repair.

D. CORRECTIVE ACTION

Where required by the Engineer as outlined herein, all diamond grinding shall be performed according to section 2900 of these Specifications, except that diamond grinding shall be conducted in increments no smaller than one 11-foot lane and one panel length.

In addition to any areas identified through the use of a 10' straightedge and by using the table below, all localized roughness areas having high points with deviations in excess of 0.3 inches in 25 feet or less shall be ground with diamond grinding equipment at the Contractor's expense. On pavement sections where corrections are necessary, second profiler runs shall be performed to verify that corrections have produced an IRI within acceptable limits, and to determine the pay adjustment, if any.

E. PAY ADJUSTMENT

The Engineer will review the profile data supplied by the Contractor for each individual wheel track to determine areas of localized roughness and the average IRI per lane per segment. Payment shall be adjusted based on the average IRI per lane per segment as follows:

	<b>Payment (Percent of Contract Unit Price)</b>				
	<b>100%</b>	<b>98% or Correct</b>	<b>95% or Correct</b>	<b>80% or Correct</b>	<b>Correct or Remove</b>
<b>PCC Pavements</b>					
<b>&gt; 30 mph</b>	<b>120</b>	<b>121-130</b>	<b>131-140</b>	<b>-----</b>	<b>&gt; 140</b>
<b>All others</b>	<b>130</b>	<b>131-140</b>	<b>141-150</b>	<b>151-160</b>	<b>&gt; 160</b>

Areas measured for roughness using a 10' straightedge shall be paid for at 100% when they are installed or corrected to within the tolerances specified above.

### 3.12. LOCATION OF EXISTING UTILITIES

Existing manholes, gate valves, and stop boxes have been shown to direct the Contractor's attention to their existence. The Contractor is cautioned that not all utilities have been shown and their location is not guaranteed. The Contractor is responsible for determining the exact location of existing utilities that affect the installation of the paving.

### 3.13. CASTING TO GRADE

Floating manhole castings as shown in the standard detail are required on all manholes located in concrete pavement. This item includes all labor, materials and equipment necessary to adjust the various castings to the proper line and grade. Note that wood shims to adjust rings and castings are not allowed. Changes in grade shall be made as follows:

All adjustments, including fine adjustments, shall be made with adjustment rings specified in Section 1500 of these Specifications. All adjustment rings shall be properly sealed in accordance with the manufacturer's recommendations and as follows: For storm sewer manholes/inlets, rings shall either be sealed watertight or be wrapped with nonwoven geotextile fabric, secured around the outside of the rings from three (3) inches below the top of the manhole/inlet structure to the top of the rings, overlapping the frame casting. For sanitary sewer manholes, rings shall be sealed water-tight from the frame casting to the manhole structure. In lieu of the use of an adhesive/sealant, an external mechanical frame-chimney seal may be used for a watertight installation.

Where casting adjustment requirements cannot be met by the use of engineered polymer adjustment rings and upon the Division Engineer's approval, the Contractor shall provide precast

reinforced concrete adjusting rings. For fine adjustments of less than two (2) inches, steel shims shall be used to temporarily support the casting. The castings and rings shall be laid in a full bed of mortar. The rings and structure section shall be cleaned to assure a flat seating surface and the rings shall be installed in alignment with no noticeable offsets. A four (4) inch wide concrete encasement shall be placed around the outside of the rings from three (3) inches below the top of the structure to the frame casting.

Care shall be taken to adjust the casting to the proper grade so the final riding surface is smooth and free of bumps and it conforms to the alignment and grade of the adjoining concrete. Any castings not satisfying these requirements shall be redone to the satisfaction of the Engineer. Castings should be set flush to 1/16 inch below the pavement surface.

The casting to grade item also includes cleaning all construction debris or dirt from the manhole or inlet bottom and installing a wiped mortar finish around the inside circumference of the precast concrete adjusting rings.

#### 3.14. CASTING TO GRADE (BOULEVARD)

This bid item shall be in accordance with Section 1200 or 1500 of these Specifications, as appropriate.

#### 3.15. CURB INLET CASTING TO GRADE

All adjustments, including fine adjustments, shall be made with HDPE adjustment rings as specified in Section 1500 of these Specifications. All adjustment rings shall be properly sealed or wrapped with nonwoven geotextile fabric in accordance with the manufacturer's recommendations.

#### 3.16. GATE VALVES TO GRADE

This item shall include all labor, material, and equipment necessary to raise or lower water gate boxes to the final grade. Care shall be taken to adjust the valve box to the proper grade so the final riding surface is smooth and free of bumps and that it conforms to the grade of the adjoining concrete. The alignment shall be checked to ensure that the box is straight and that the valve is operable. Any valve boxes not satisfying these requirements shall be redone to the satisfaction of the Engineer. Valve boxes should be set within 1/16 inch of the finished pavement surface.

The gate box to grade item also includes cleaning all construction debris or dirt from the box, insuring that the box is straight and undamaged, and insuring that the valve is operable.

### 3.17. TESTING

The Engineer may take samples and make tests to assure that the work is being performed in accordance with these Specifications. The Contractor shall cooperate in the making of such tests to the extent of allowing free access to the work, for the selection of samples.

Samples shall be obtained and tested in accordance with the latest ASTM methods of tests. Testing labs shall supply reports to the Engineer, Contractor, and concrete supplier.

### 3.18. OPENING TO TRAFFIC

Newly constructed pavement shall not be opened to Contractor or public traffic until the concrete has attained a compressive strength of 3,000 psi, as determined by breaking test cylinders cured in the field in a manner that replicates as closely as possible the curing conditions of the pavement. In addition to the strength requirements, the newly constructed concrete pavement shall not be opened to any traffic until all joints have been sealed unless permission is granted by the Engineer. The Contractor shall erect and maintain suitable barricades and lights to protect the pavement from traffic. Any part of the pavement damaged from traffic or other causes occurring prior to the acceptance of the pavement shall be repaired to the satisfaction of the Engineer at the Contractor's sole expense.

The Contractor shall receive written notice from the Engineer to open the pavement to traffic and shall then dispose of all covering material as directed and remove all barricades.

### 3.19. SIDEWALKS AND DRIVEWAYS

The construction of sidewalks, driveways and impressed concrete shall be done in accordance with Section 2300.



**PART 4**  
**GUARANTEE, MEASUREMENT & PAYMENT**

4.1. GUARANTEE

The guarantee shall be per the contract.

4.2. MEASUREMENT AND PAYMENT

Payment for concrete paving and castings and gate valves to grade shall be full compensation for all labor, material, equipment and miscellaneous items necessary for constructing these items in place.

*4.2.1. EXCAVATION AND SUBGRADE PREPARATION*

Paid under Section #2000 contract bid items.

*4.2.2. UNDER-STRENGTH CYLINDERS OR BEAMS*

Payment for PCC specified herein will not be made until the Engineer is satisfied that the material will meet the specified strength requirements. When test cylinders show under-strength PCC, cores shall be taken in the field and tested. The number and location of the cores will be at the discretion of the Engineer. All costs for coring and retesting will be deducted from the Contractor's payment. All PCC found to be under-strength shall be removed and replaced at the Contractor's sole expense.

*4.2.3. CONCRETE PAVEMENT*

Concrete pavement shall be paid for at the unit price bid per square yard. Concrete pavement shall include the area of paving only and does not include the area of the curb or gutter pan.

*4.2.4. CONCRETE CURB AND GUTTER*

Curb and gutter will be measured along the curb face and be paid for at the contract unit price per linear foot. Where integral curb is poured, paving and curb payment will be based on a standard 30" wide curb and gutter section.

*4.2.5. CONCRETE VALLEY GUTTERS*

Valley gutters will be measured and paid for at the unit price bid per square yard.

*4.2.6. CONCRETE SIDEWALKS, DRIVEWAYS, AND IMPRESSIONED CONCRETE*

Sidewalks, driveways, and impressioned concrete shall be in accordance with Section 2300.

*4.2.7. CASTINGS TO GRADE*

This bid item shall include all work to adjust the casting with up to 4 rings, including all sealant, wrap, or chimney seals as specified herein. Adjustments to inlets and manholes located in the pave shall be paid for under the "Casting to Grade – w/Conc" bid item. Adjustments to inlets and manholes located outside the pave shall be paid for under the "Casting to Grade – Blvd" bid item.

*4.2.8. VALVE BOXES TO GRADE*

Adjustments to valve boxes located in the pave shall be paid for under the "GV Box to Grade – w/Conc" bid item. Adjustments to valve boxes located outside the pave shall be paid for under the "GV Box to Grade – Blvd" bid item.

*4.2.9. SMOOTHNESS AND GRINDING*

Payment adjustment will be as specified in Section 3 above for the smoothness requirement designated.

*4.2.10. OTHER COSTS*

All costs of reinforcing steel, curing and protection, jointing and joint filling/sealing, and all other costs of work necessary to properly complete the work specified herein shall not be bid items; the costs shall be charged to other items unless a bid item is included on the bid sheet.

CONCRETE PAVEMENT WIDTH	BACK-TO-BACK WIDTH A	GRAVEL BASE WIDTH B	SLAB THICKNESS C	GRAVEL THICKNESS D	% CROSS SLOPE E	CROSS-CROWN HEIGHT BELOW TOP OF CURB		PANEL HEIGHT F	CENTER PANEL WIDTH-G	OUTSIDE PANEL WIDTH-H	ENGINEERING FABRIC
						STD	MNTBLE				
32'	33'	35'	8"	8"	2.35%	1 1/2" BELOW	1/2" ABOVE	12'	8'	8.5'	ENG. FABRIC
36'	37'	39'	8"	8"	2.30%	1" BELOW	1" ABOVE	12'	9'	9.5'	ENG. FABRIC
40'	41'	43'	9"	8"	2.30%	1/2" BELOW	1 1/2" ABOVE	15'	10'	10.5'	ENG. FABRIC
51'	52'	54'	9"	12"	2.30%	1" ABOVE	N/A	15'	12'	12'	ENG. FABRIC
63'	64'	66'	10"	12"	2.25%	2 1/2" ABOVE	N/A	15'	11'	12'	ENG. FABRIC

\*NOTE: CENTER PANEL IS CENTERED ON R/W, TOTAL OF 4-12' AND 1-11' PANELS

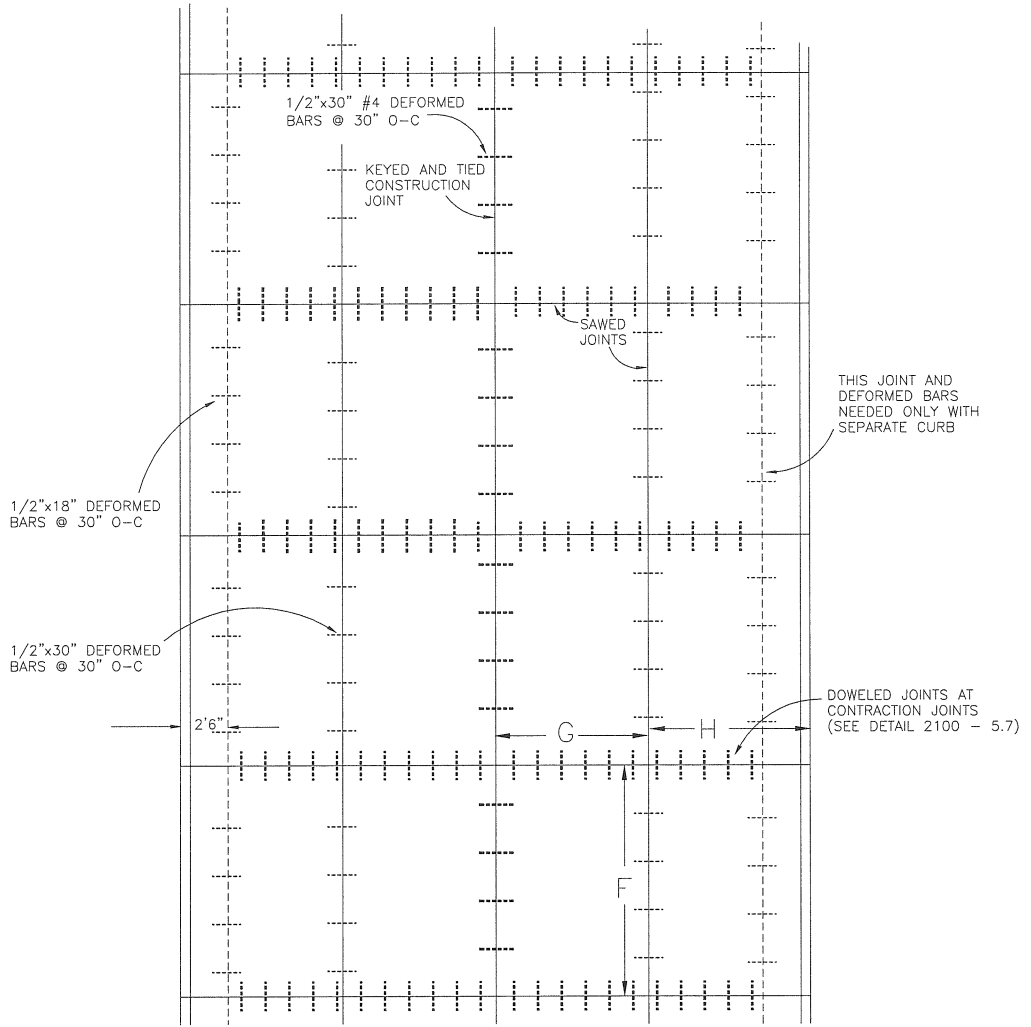

PLAN VIEW

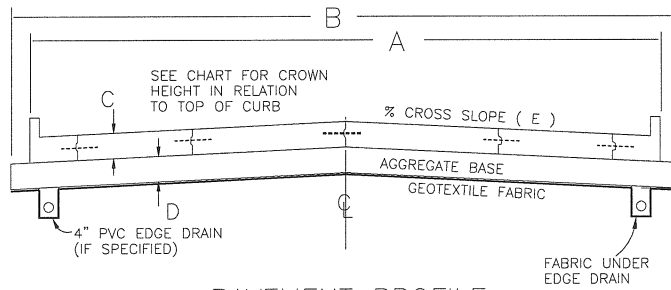

PAVEMENT PROFILE

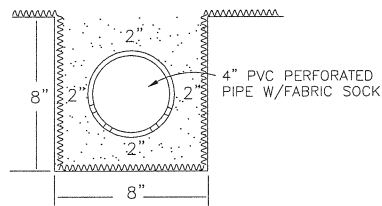

TRENCH DETAIL

SECTION NO.	2100	DRAWING NO.	5.1
REV.D.	2012		
<b>DOWELED CONCRETE PAVEMENT</b>			
CITY OF FARGO ENGINEERING DEPARTMENT			
APPROVED	<i>BEO</i>	DATE	<i>2-21-2012</i>

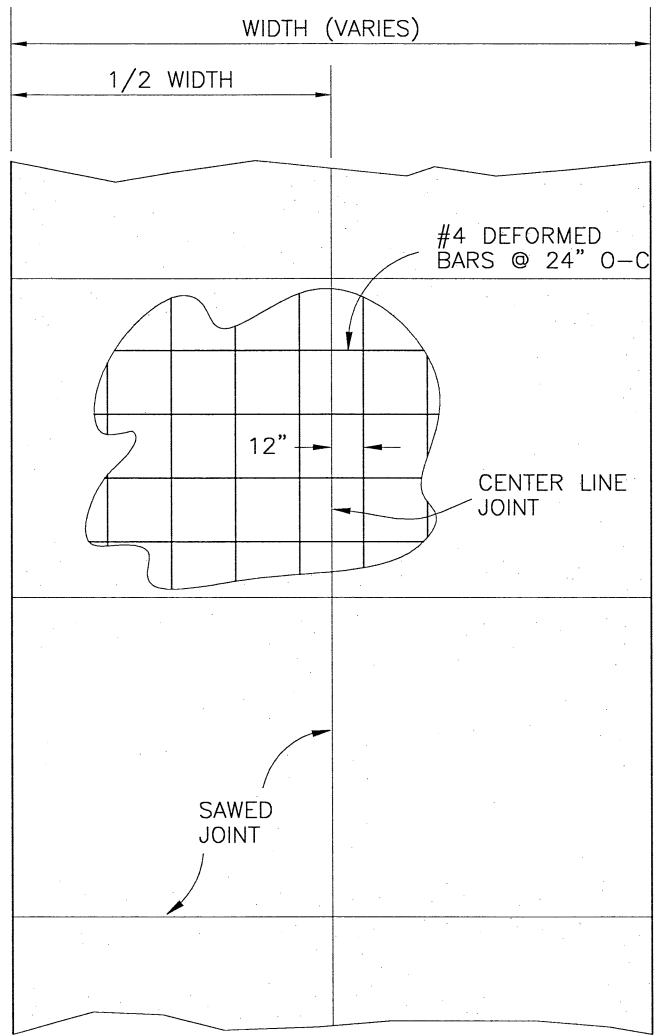

- NOTES:
1. JOINTS SHALL BE SAW CUT AND SEALED AS PER SECTION JOINT FILLING AND SEALING.
  2. 3" AGGREGATE BASE SHALL BE INCLUDED IN THE CONCRETE PAVEMENT BID ITEM.
  3. ALL CONSTRUCTION JOINTS SHALL BE TIED WITH #4 X 18" DEFORMED BARS @ 24" O-C.

PLAN

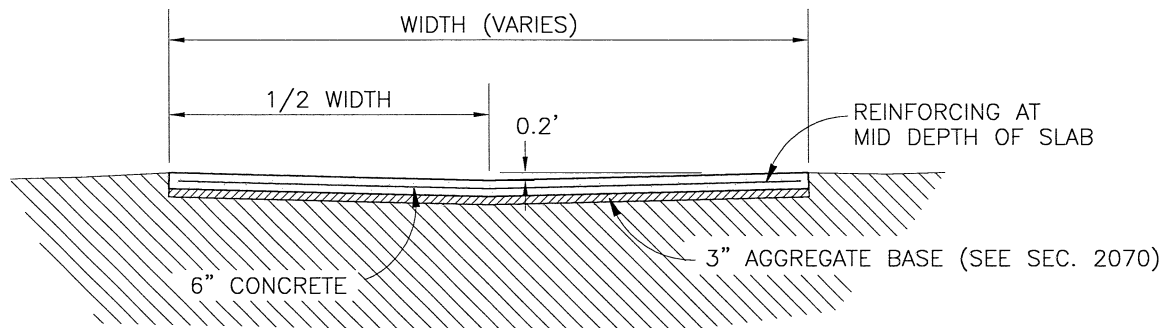

SECTION

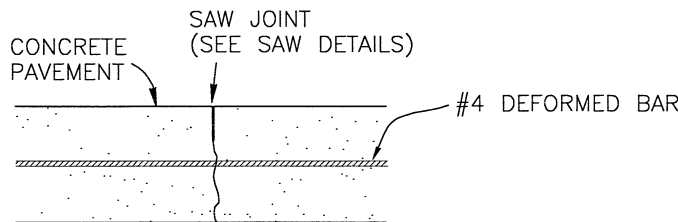

SAWED JOINT DETAIL

SECTION NO. 2100	DRAWING NO. 5.2
REV.D. 2014	
<b>REINFORCED CONCRETE ALLEY DETAILS</b>	
CITY OF FARGO ENGINEERING DEPARTMENT	
APPROVED <i>OME</i>	DATE 12/18/13

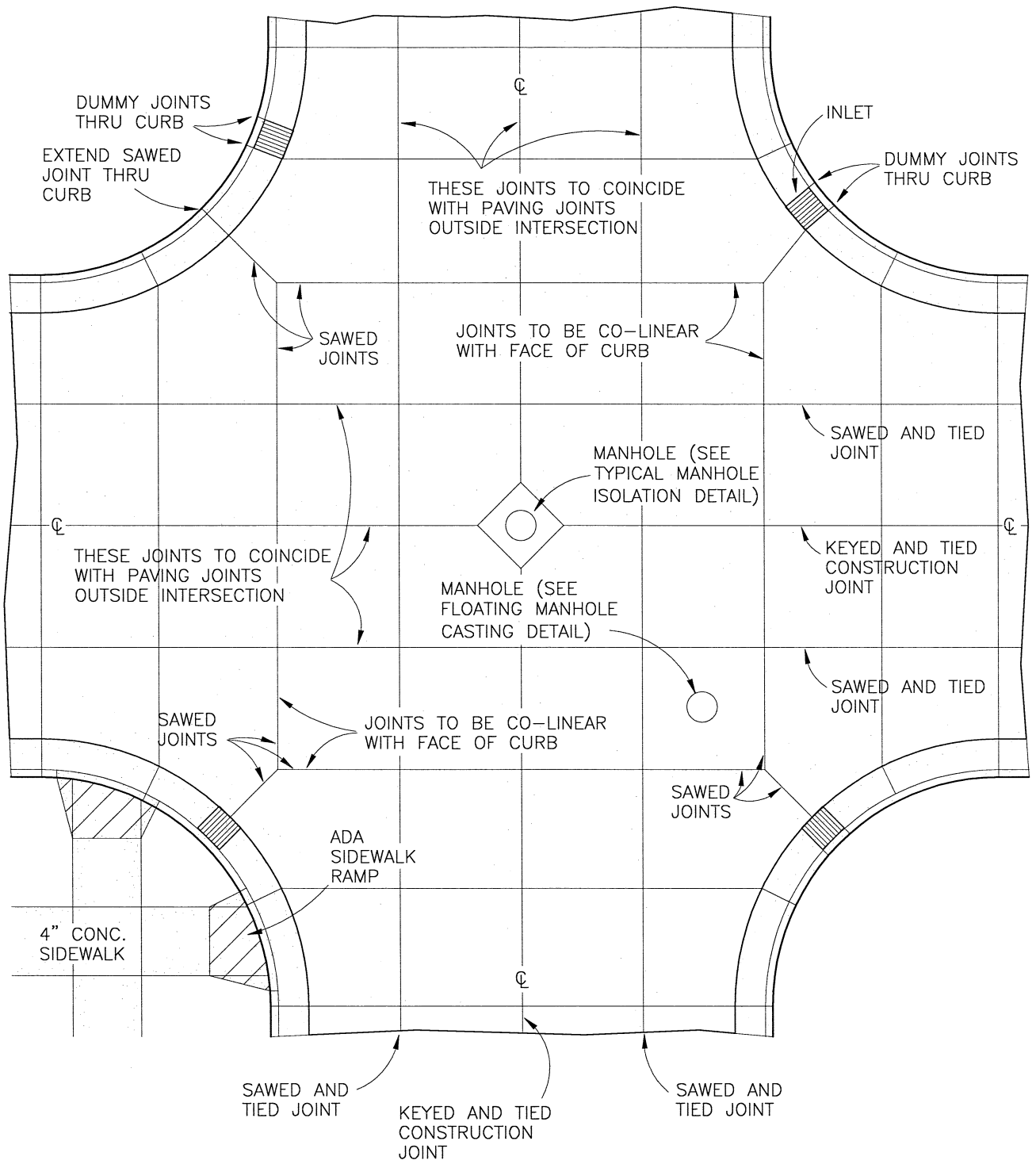

- NOTES:
1. ALL DIMENSIONS ARE VARIABLE, SEE PLANS AND PROPER CONCRETE PAVEMENT DETAIL FOR DIMENSIONS
  2. CURB AND GUTTER MAYBE INSTALLED INTEGRAL WITH THE CONCRETE PAVEMENT, EXCEPT AT THE FOLLOWING LOCATIONS WHERE IT SHALL BE INSTALLED SEPARATE:
    - A. ALL RADII (PC TO PC) THAT INCLUDE INLET CASTINGS.
    - B. ONE FULL PANEL HEIGHT ON EACH SIDE OF INLET CASTINGS NOT LOCATED IN A RADIUS.

SECTION NO. 2100	DRAWING NO. 5.3
REV.D. 2014	
<b>TYPICAL CONCRETE INTERSECTION LAYOUT</b>	
CITY OF FARGO ENGINEERING DEPARTMENT	
APPROVED <i>BME</i>	DATE 12/18/13

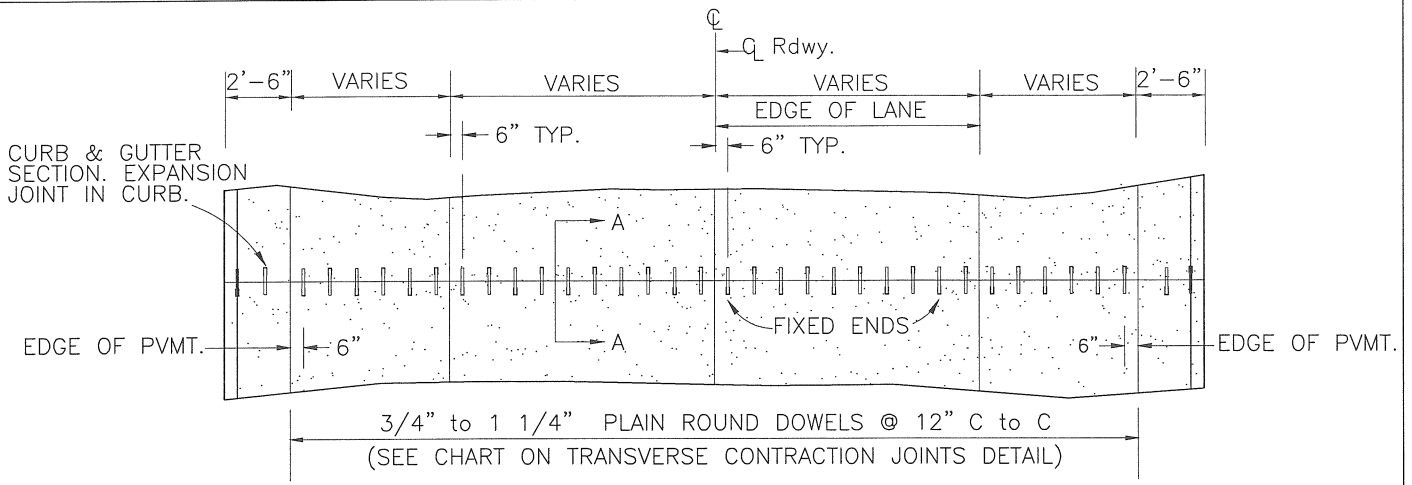

DOWEL BAR ASSEMBLY

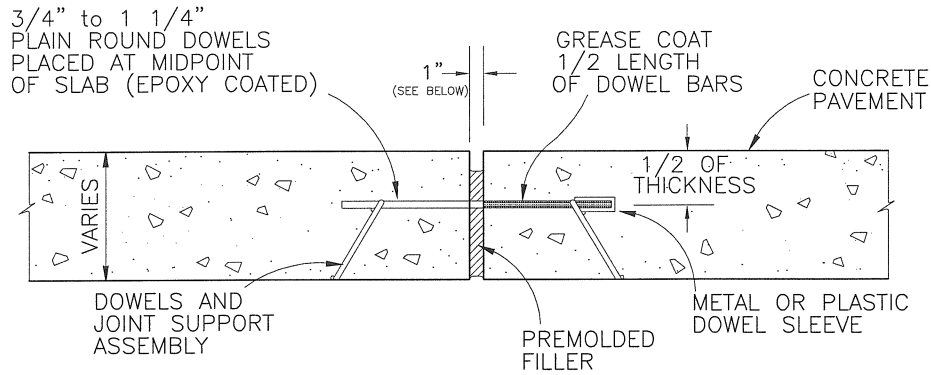

SECTION A-A

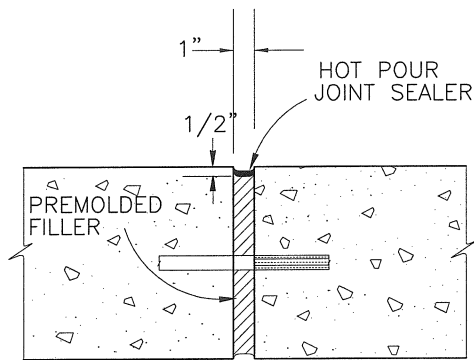

HOT POUR SEAL  
(UNLESS OTHERWISE NOTED)

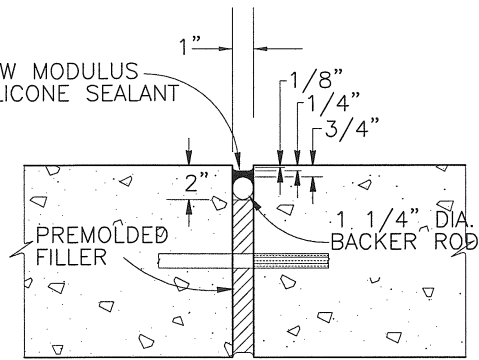

SILICONE SEAL  
(IF SPECIFIED)

- NOTES:
1. EXPANSION JOINT LOCATIONS SHOWN ON PLANS.
  2. EXPANSION JOINTS MUST BE INSTALLED ACROSS ENTIRE WIDTH OF CONCRETE PAVEMENT.
  3. PREMOLDED FILLER MUST CONFORM TO THE DIMENSIONS OF THE TYPE OF CURB.

SECTION NO.	2100	DRAWING NO.	5.4
REV.D.	2012		
<b>EXPANSION JOINT DETAIL</b>			
CITY OF FARGO ENGINEERING DEPARTMENT			
APPROVED	<i>BED</i>	DATE	<i>2-21-2012</i>

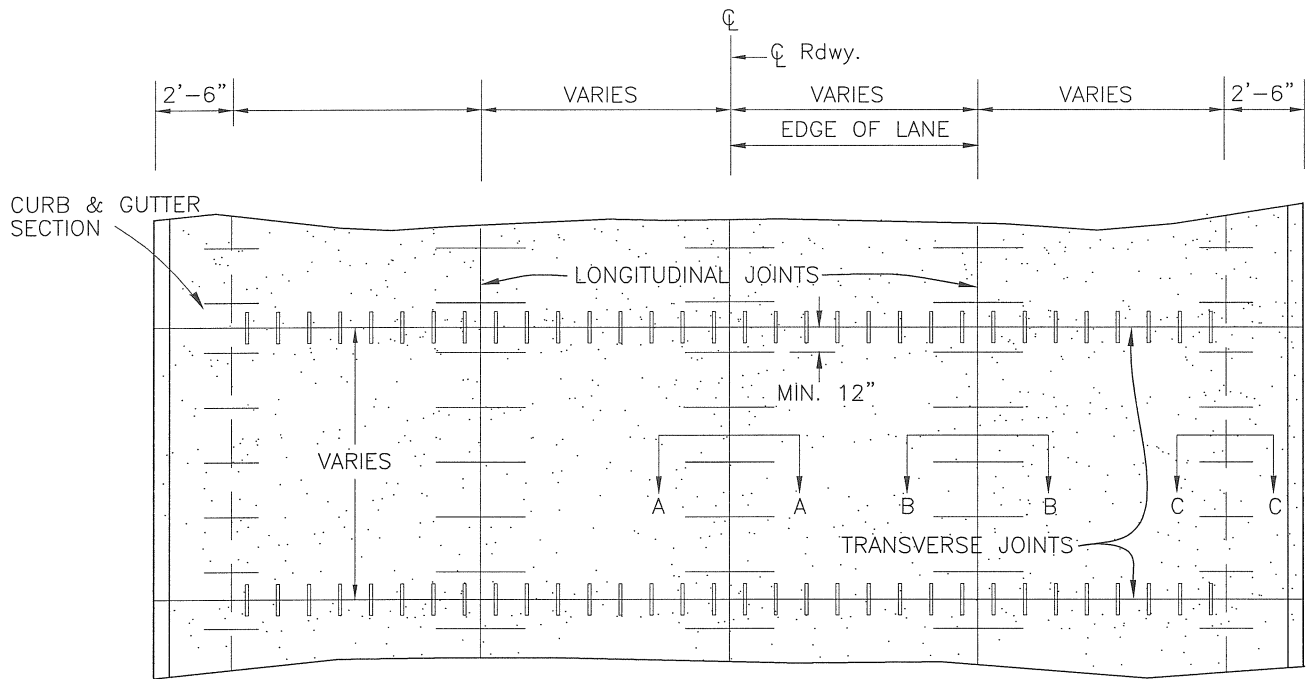

LONGITUDINAL JOINTS

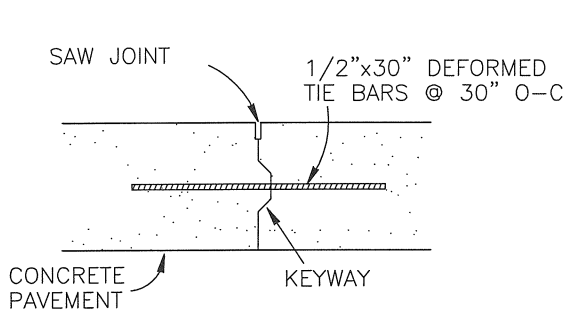

SECTION A-A  
LONGITUDINAL CONSTRUCTION JOINT

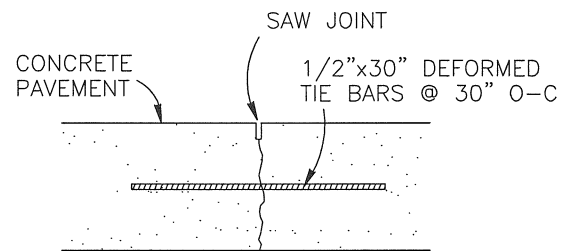

SECTION B-B  
SAWED LONGITUDINAL JOINT

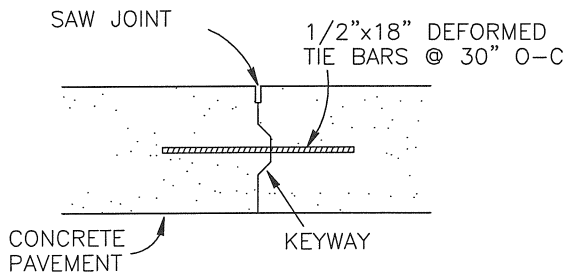

SECTION C-C  
LONGITUDINAL CONSTRUCTION JOINT

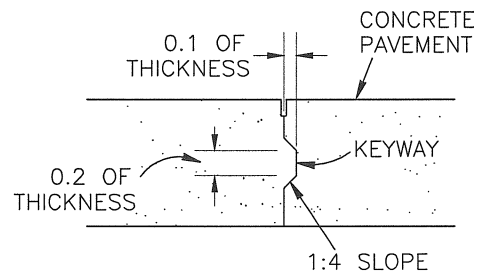

STANDARD KEYWAY  
DIMENSIONS

NOTES:

1. ALL LONGITUDINAL JOINTS SHALL BE TIED AND ALL LONGITUDINAL CONSTRUCTION JOINTS SHALL BE BOTH KEYED AND TIED.
2. SECTION C-C, THE JOINT AND DEFORMED TIE BARS NEEDED ONLY WITH SEPARATE CURB
3. SEE SAW JOINT DETAILS
4. WHERE TIE BARS ARE INSTALLED AND LATER STRAIGHTENED, GRADE 40 STEEL SHALL BE USED
5. ALL TIE BARS SHALL BE EPOXY COATED IN ACCORDANCE WITH AASHTO M284

SECTION NO. 2100	DRAWING NO. 5.5
REV.D. 2012	
<b>LONGITUDINAL JOINTS</b>	
CITY OF FARGO ENGINEERING DEPARTMENT	
APPROVED <i>BEO</i>	DATE <i>2-21-2012</i>

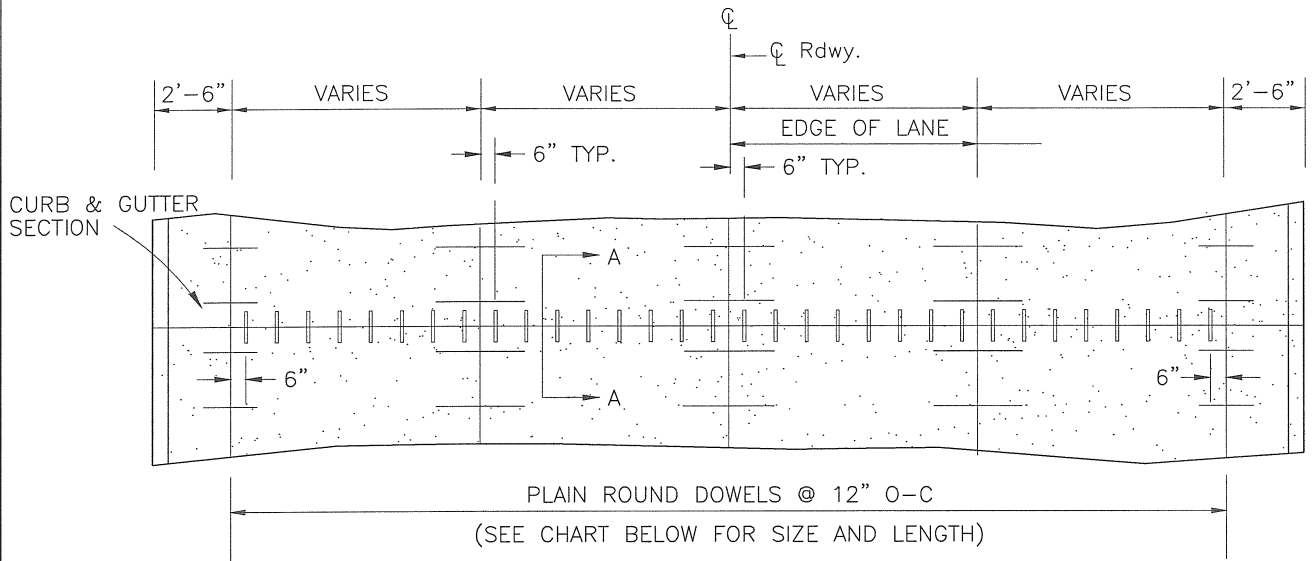

TRANSVERSE CONTRACTION JOINT

DOWEL ASSEMBLY

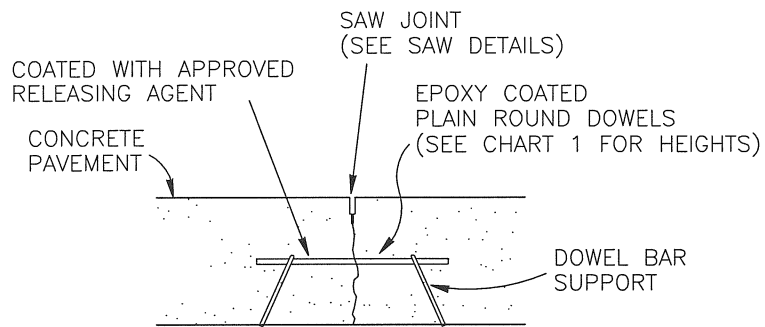

SECTION A-A

DOWEL ASSEMBLY

NOTES:

1. ALL DOWELS SHALL BE EPOXY COATED IN ACCORDANCE WITH AASHTO M254.

CHART 1

DOWELED JOINT			
PAVEMENT THICKNESS	DOWEL BAR SIZE	HEIGHT TO CENTER	TOTAL DOWEL LENGTH
7"	1"	3 1/2"	18"
8 to 10"	1 1/4"	4 1/2"	18"
10.5 to 12"	1 1/2"	5 1/2"	18"
NOTE: ALL DOWELS ARE TO BE SPACED AT 12" O-C			

SECTION NO. 2100	DRAWING NO. 5.6
REV.D. 2012	
<b>TRANSVERSE CONTRACTION JOINTS</b>	
CITY OF FARGO ENGINEERING DEPARTMENT	
APPROVED <i>BED</i>	DATE <i>2-21-2012</i>



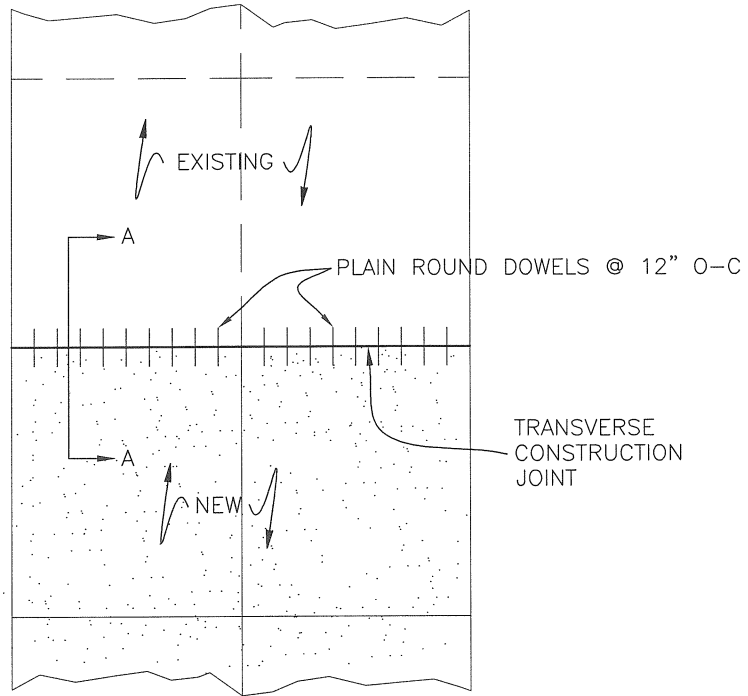

CONSTRUCTION JOINT  
EXISTING TO NEW CONCRETE PAVEMENT

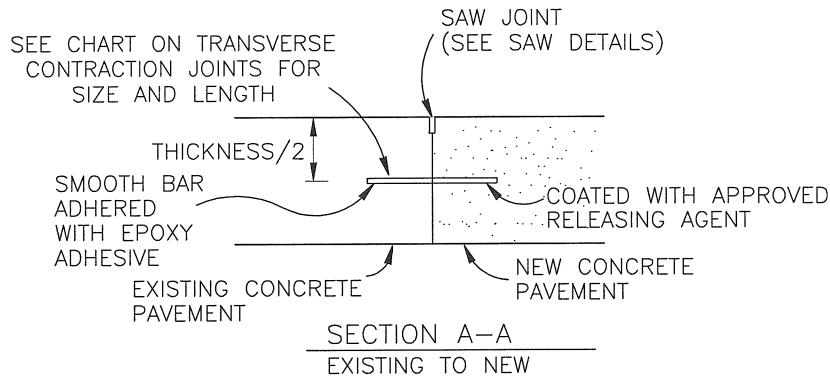

SECTION A-A  
EXISTING TO NEW

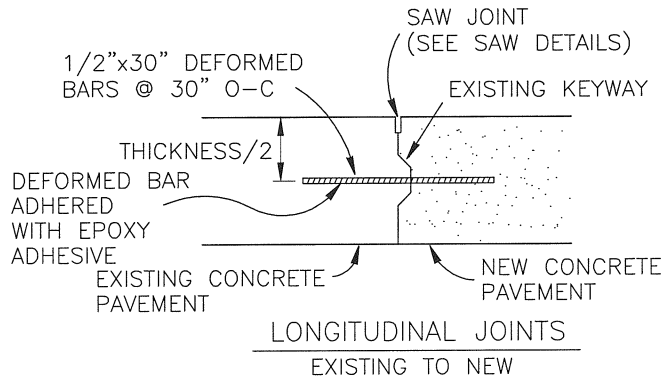

LONGITUDINAL JOINTS  
EXISTING TO NEW

SECTION NO.	2100	DRAWING NO.	5.7
REV.D.	2012		
<b>CONSTRUCTION JOINT DETAILS</b>			
CITY OF FARGO ENGINEERING DEPARTMENT			
APPROVED	<i>BEO</i>	DATE	2-21-2012

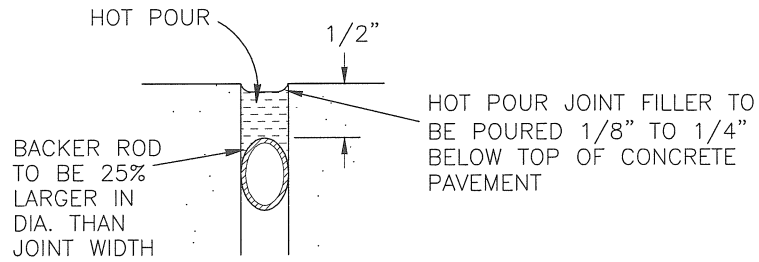

JOINT FILLER DETAIL  
(SEE NOTE 1)

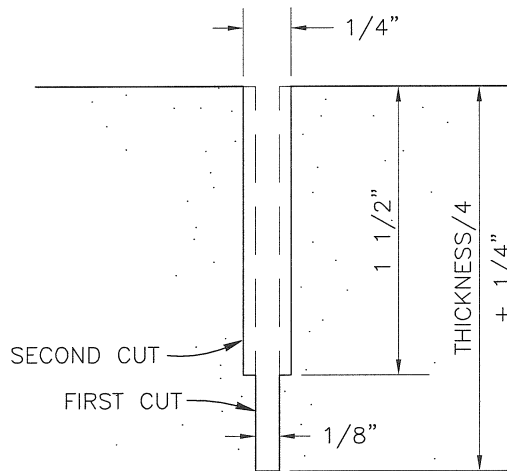

SAW JOINT DETAIL  
(SEE NOTE 2)

NOTES:

1. THE JOINT FILLER DETAIL APPLIES TO BOTH TRANSVERSE AND LONGITUDINAL JOINTS.
2. SAW JOINT DETAIL – THE FIRST & SECOND CUT SHALL BE COMPLETED ON ALL CONTRACTION JOINTS. ON ALL CONSTRUCTION JOINTS ONLY A CUT CONFORMING TO THE DIMENSIONS OF THE SECOND CUT SHOWN SHALL BE COMPLETED.
3. ALL JOINTS SHALL BE FILLED.

SECTION NO. 2100	DRAWING NO. 5.8
REV.D. 2012	
<i>SAW JOINT DETAIL</i>	
CITY OF FARGO ENGINEERING DEPARTMENT	
APPROVED <i>TBED</i>	DATE <i>2-21-2012</i>

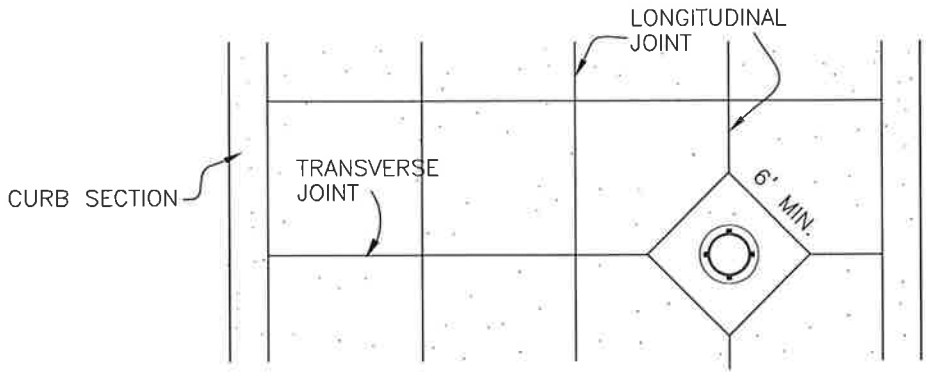

PLAN VIEW

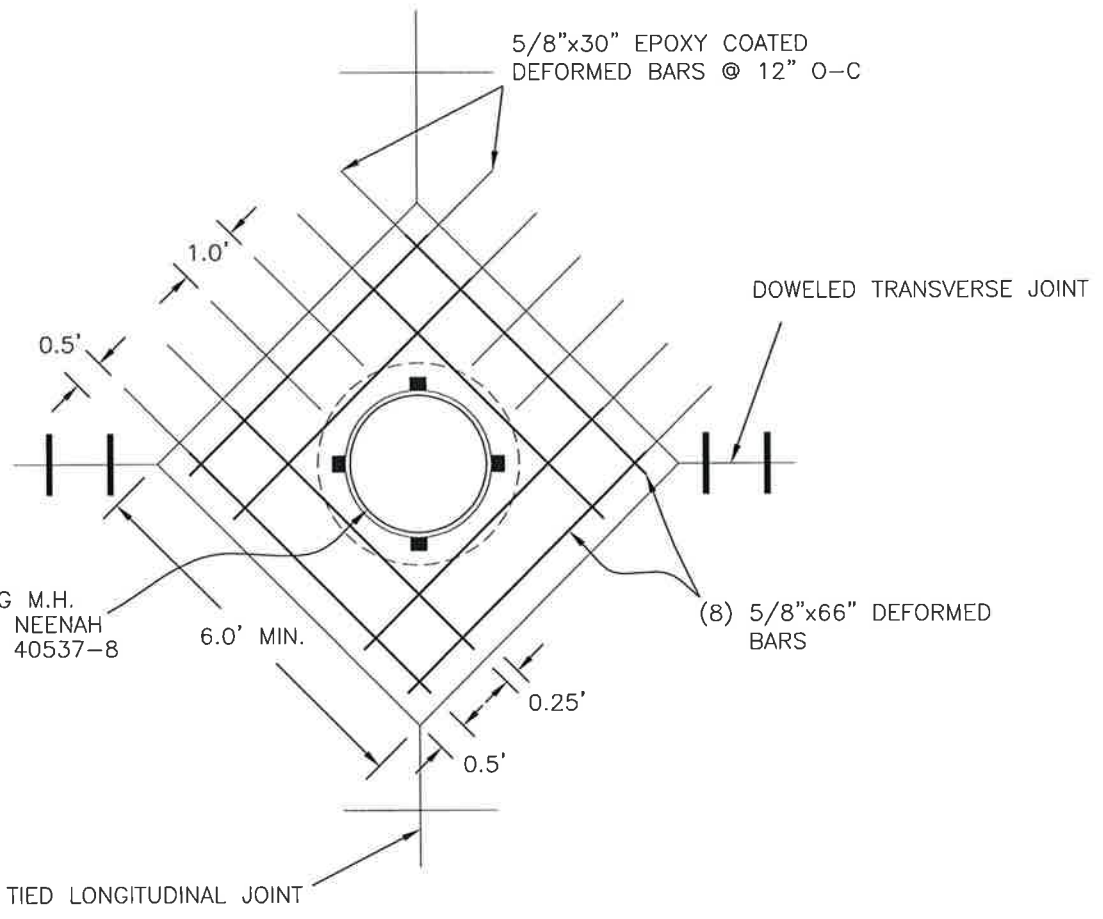

MANHOLE ISOLATION DETAIL

R-1955-1 FLOATING M.H. VERSION, REFER TO NEENAH FOUNDRY DWG. NO. 40537-8

NOTE:  
 1. ALL 4 SIDES SHALL BE KEYED W/2 SIDES BEING KEYED AND TIED AS SHOWN. SEE LONGITUDINAL JOINTS DETAIL FOR KEYWAY DIMENSIONS.

SECTION NO.	2100	DRAWING NO.	5.9
REV.D.	2015		
<b>TYPICAL MANHOLE ISOLATION DETAIL</b>			
CITY OF FARGO ENGINEERING DEPARTMENT			
APPROVED	<i>CME</i>	DATE	<i>12/3/14</i>

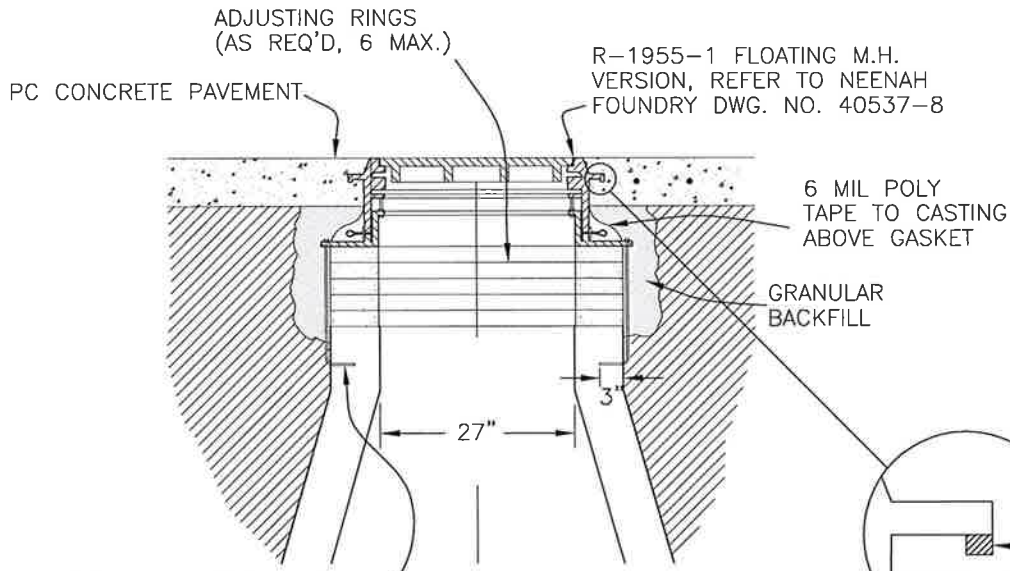
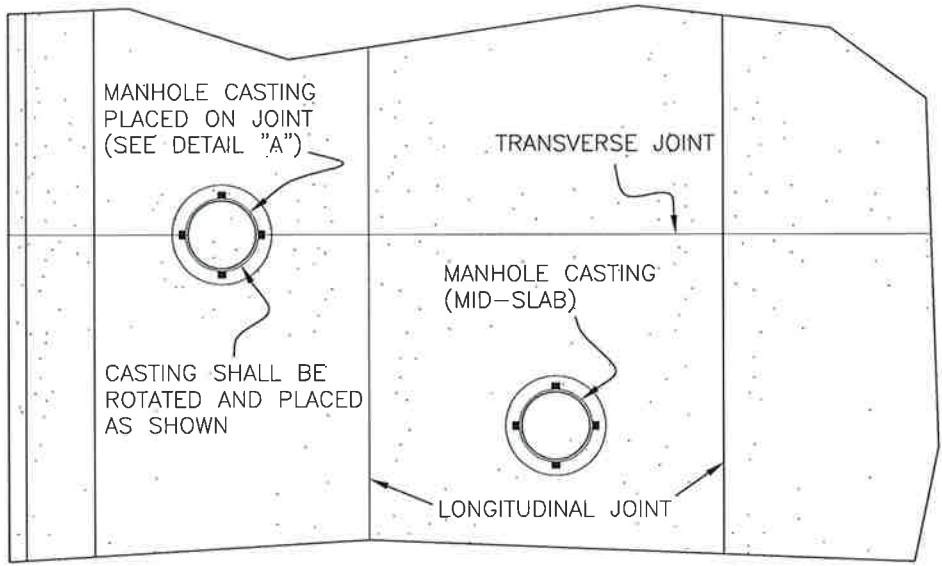

3/4" DIA S.S "J" BOLT W/NUT, TO EXTEND 5" BELOW ADJ. RINGS, 4 PER CASTING, LENGTH TO VARY WITH NUMBER OF ADJUSTING RINGS

FLOATING MANHOLE  
NEENAH FOUNDRY TYPE

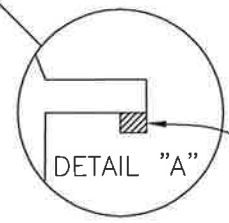

REMOVE ALL (4) HOOK PORTIONS FROM THE FLANGES, WHEN CASTING IS PLACED ON TRANSVERSE JOINTS AND COAT OUTER SURFACE OF CASTING W/APPROVED RELEASING AGENT

- NOTES:
1. THIS DETAIL APPLIES TO ALL MH's LOCATED WITHIN THE CONCRETE PAVING SECTION.
  2. FURNISH / INSTALL WILL BE PAID UNDER THE "CASTING TO GRADE" BID ITEM.

SECTION NO. 2100	DRAWING NO. 5.10
REV.D. 2015	
<b>FLOATING MANHOLE CASTING DETAIL</b>	
CITY OF FARGO ENGINEERING DEPARTMENT	
APPROVED <i>CME</i>	DATE 12/3/14

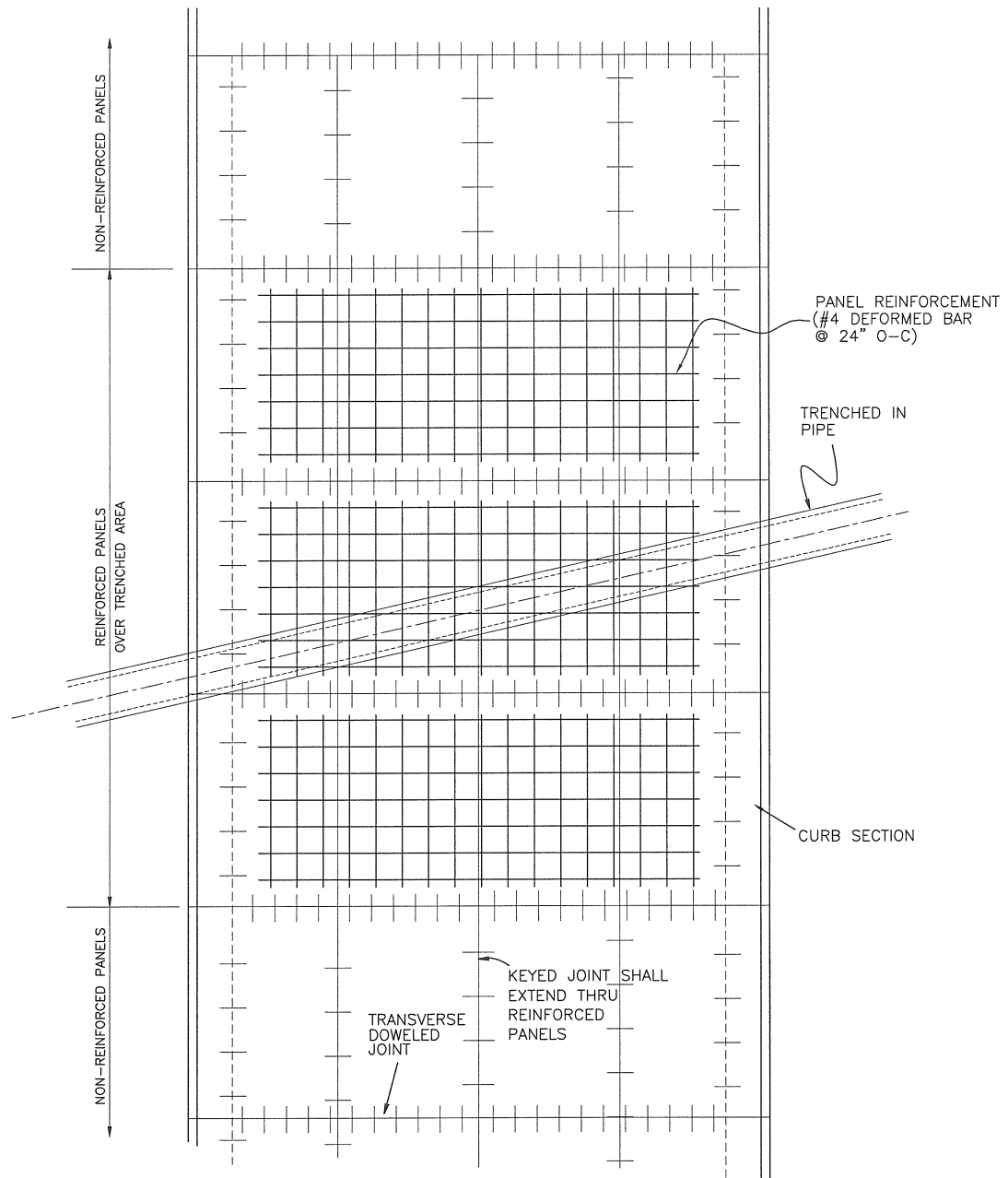

NOTES:

1. AREAS FOR REINFORCEMENT SHALL BE DETERMINED BY THE ENGINEER USING THE PLAN SHEETS AS A GUIDELINE. PAYMENT FOR REINFORCEMENT SHALL BE INCIDENTAL TO THE PRICE OF THE CONCRETE PAVEMENT.
2. THE COMPLETE PANEL SHALL BE REINFORCED IF ANY PART OF THE PANEL IS WITHIN 5' OF THE PIPE CENTERLINE.
3. REBAR MAT SHALL BE SUPPORTED BY CHAIRS AT THE MID-DEPTH POINT OF THE SLAB.
4. REBAR SHALL STOP WITHIN 1' OF THE DOWELED CONTRACTION JOINT AT THE ADJACENT NON-REINFORCED PANEL.

SECTION NO.	2100	DRAWING NO.	5.11
REV.D.	2012		
<b>TRENCH REINFORCEMENT DETAIL</b>			
CITY OF FARGO ENGINEERING DEPARTMENT			
APPROVED	<i>BEO</i>	DATE	<i>2-21-2012</i>

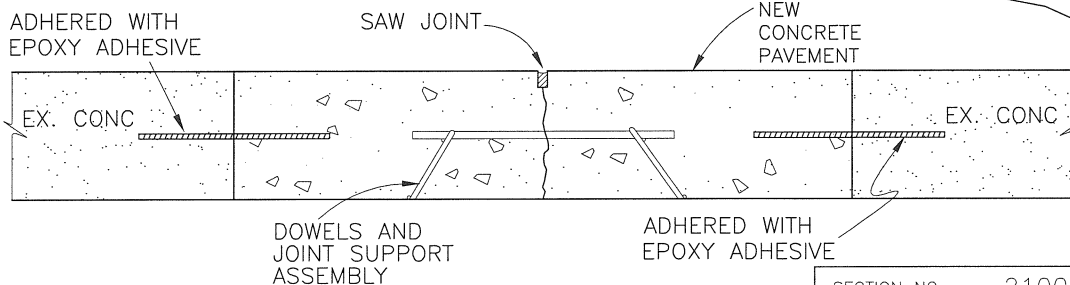
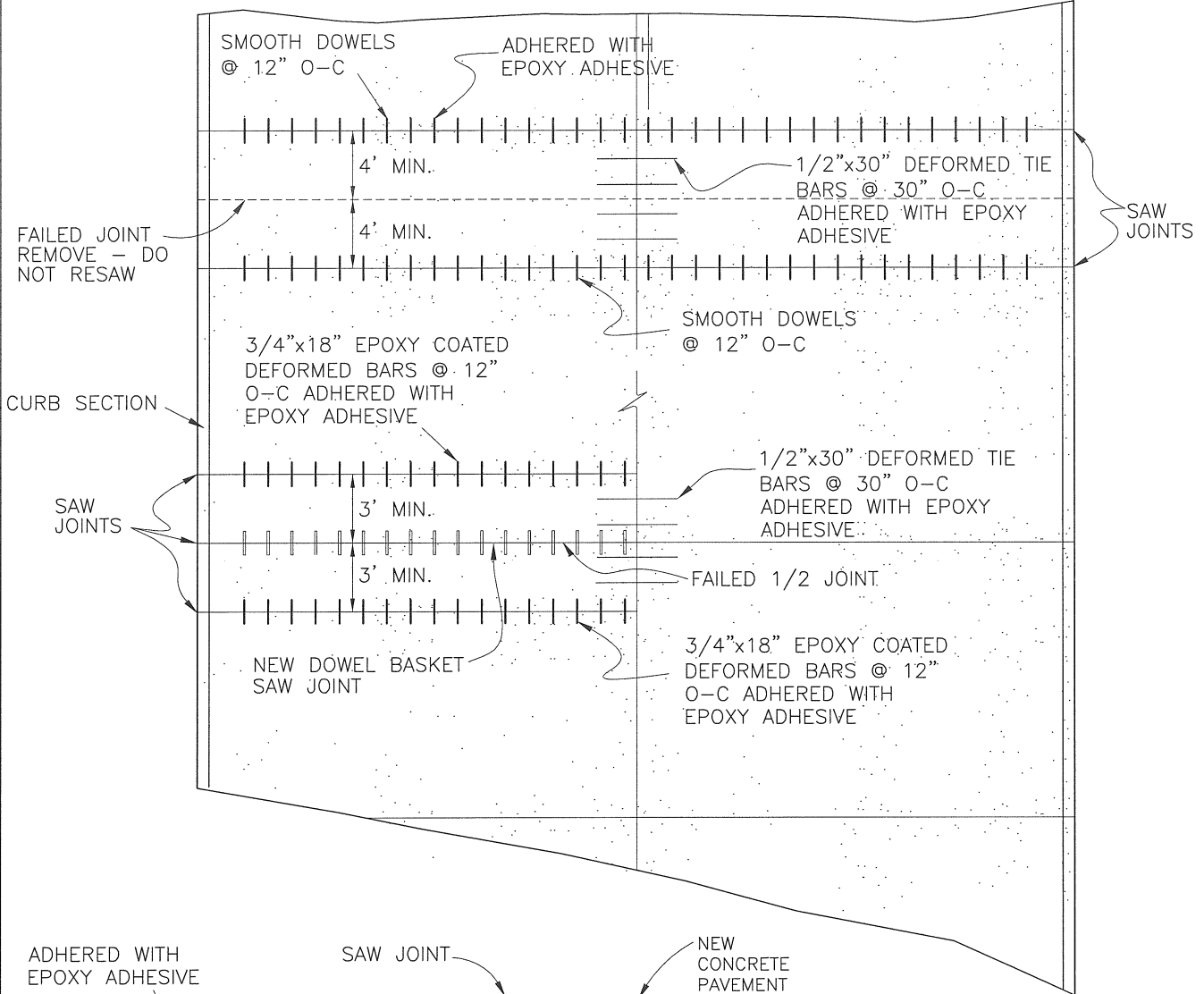
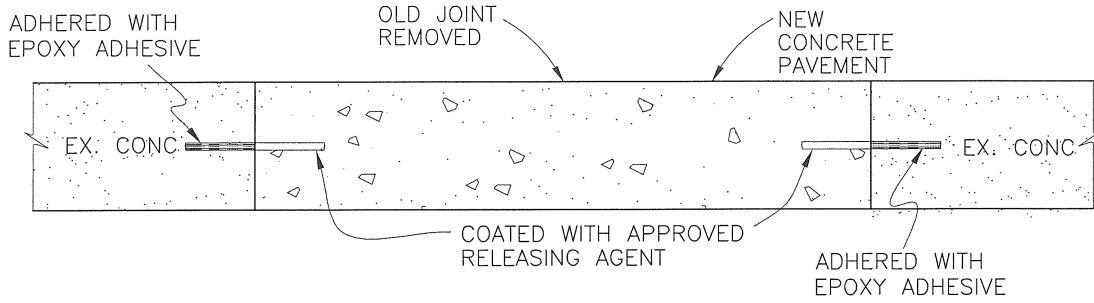

- NOTES:
1. SMOOTH DOWELS - SEE CHART ON TRANSVERSE CONTRACTION JOINTS DETAIL FOR SIZE AND LENGTH.
  2. SEE SAW JOINT DETAIL.
  3. THIS DETAIL SHALL ONLY APPLY TO REHABILITATION PROJECTS WHERE DESIGNATED ON THE PLANS.

SECTION NO. 2100 DRAWING NO. 5.12

REV.D. 2012

**JOINT REPAIR  
DETAIL**

CITY OF FARGO  
ENGINEERING DEPARTMENT

APPROVED *BEO*

DATE 2-21-2012

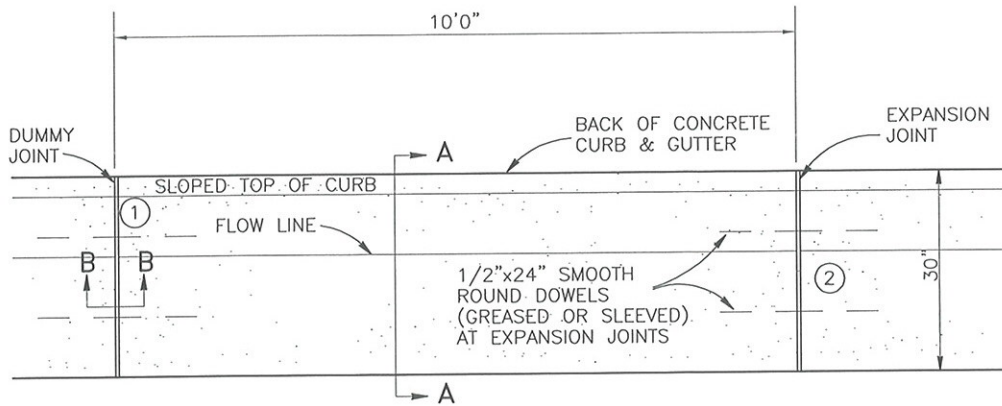

### CURB & GUTTER PLAN

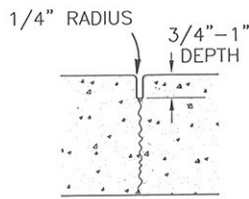

SECTION B-B

- ① DUMMY JOINT
  - (1) PLACE AT 10'0" O.C. FOR ASPHALT PAVING
  - (2) MATCH PANEL SPACING FOR CONCRETE PAVEMENT
- ② 1" EXPANSION JOINTS
  - (1) PLACE AT P.C.'S AND HIGH POINTS FOR ASPHALT PAVING
  - (2) MATCH EXPANSION JOINTS ON CONCRETE PAVEMENT

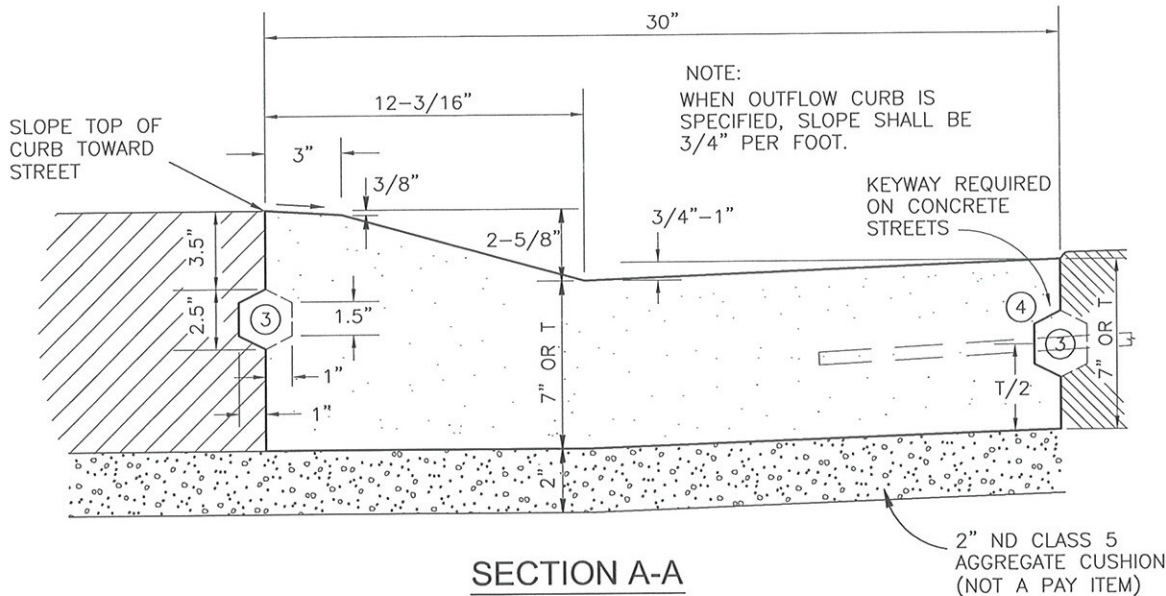

SECTION A-A

- ③ NOTE:
  - (1) MALE KEYWAY REQUIRED FOR EXTRUDED CURB CONSTRUCTION
  - (2) FEMALE KEYWAY FOR USE WITH FORMS (INDICATED WITH DASHED LINES)
- ④ 1/2"x18" DEFORMED BARS AT 30" O.C. & KEYWAY REQUIRED WHEN SEPARATE CURB IS INSTALLED WITH CONCRETE PAVING

NOTE:  
DIMENSION T SHALL MATCH THE THICKNESS OF THE ADJOINING CONCRETE SLAB WITH EITHER INTEGRAL OR SEPARATE CURB

SECTION NO. 2100	DRAWING NO. 5.13
REV.D. 2013	
<b>MOUNTABLE (TYPE I) CURB &amp; GUTTER</b>	
CITY OF FARGO ENGINEERING DEPARTMENT	
APPROVED <i>OME</i>	DATE 1-2-13



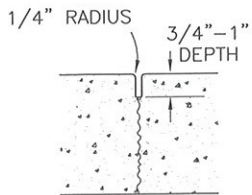
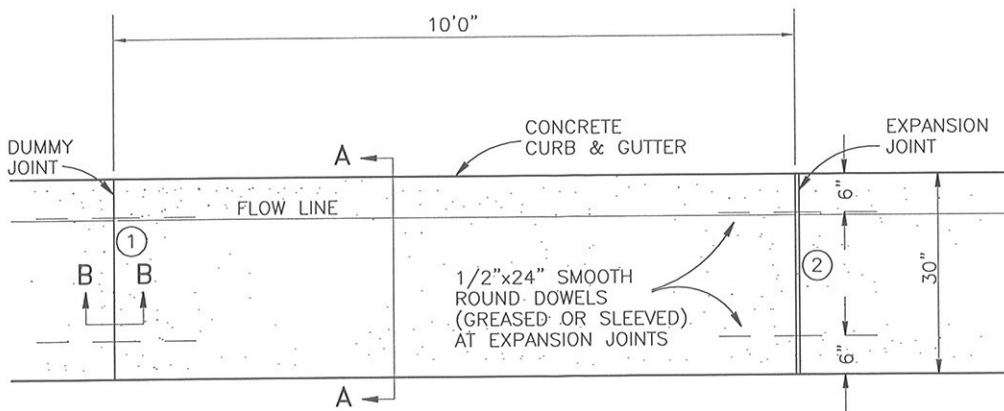

SECTION B-B

**CURB & GUTTER PLAN**

- ① DUMMY JOINT
  - (1) PLACE AT 10'0" O.C. FOR ASPHALT PAVING
  - (2) MATCH PANEL SPACING FOR CONCRETE PAVEMENT
- ② 1" EXPANSION JOINTS
  - (1) PLACE AT P.C.'S AND HIGH POINTS FOR ASPHALT PAVING
  - (2) MATCH EXPANSION JOINTS ON CONCRETE PAVEMENT

NOTE:  
WHEN OUTFLOW CURB IS SPECIFIED SLOPE WILL BE 3/8" PER FOOT

CURB SECTION WHEN DROPPED FOR DRIVEWAY OR PUBLIC SIDEWALK OPENING.  
(1.5' TRANSITION CURB FOR SIDEWALK AND DRIVEWAY)

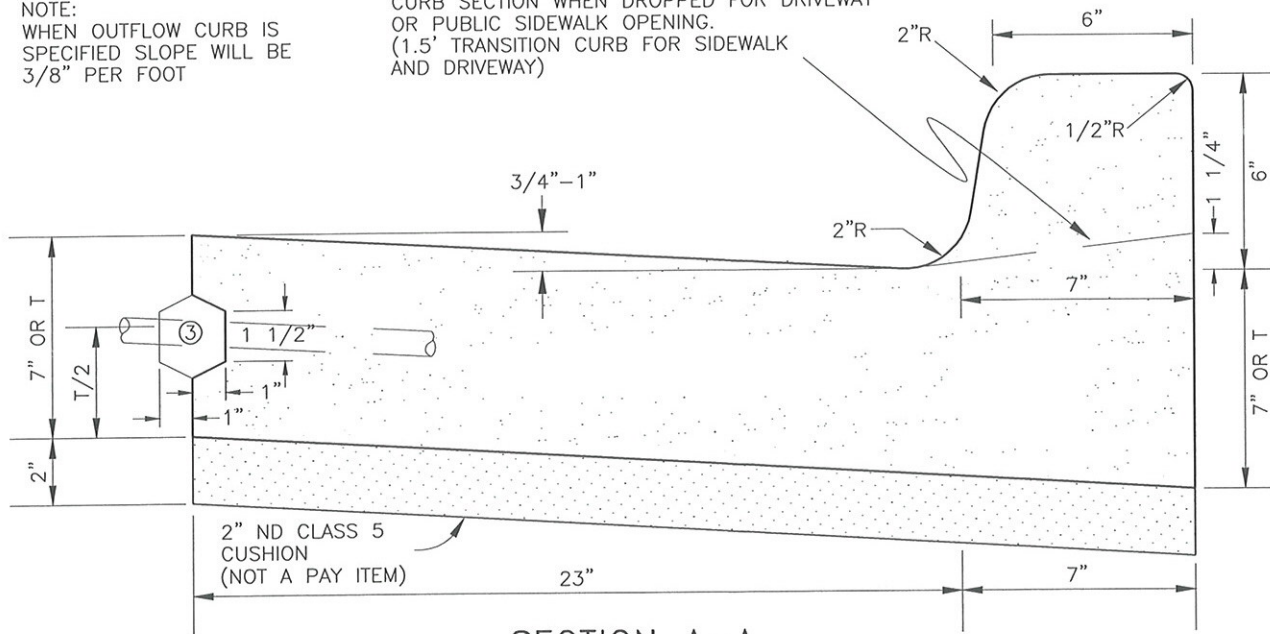

SECTION A-A

- ③ 1/2"x18" DEFORMED BARS AT 30" O.C. & KEYWAY REQUIRED WHEN SEPARATE CURB IS INSTALLED WITH CONCRETE PAVING

NOTE:  
DIMENSION T SHALL MATCH THE THICKNESS OF THE ADJOINING CONCRETE SLAB WITH EITHER INTEGRAL OR SEPARATE CURB

SECTION NO. 2100	DRAWING NO. 5.14
REV.D. 2013	
<b>STANDARD (TYPE II) CURB &amp; GUTTER</b>	
CITY OF FARGO ENGINEERING DEPARTMENT	
APPROVED <i>CME</i>	DATE 1-2-13



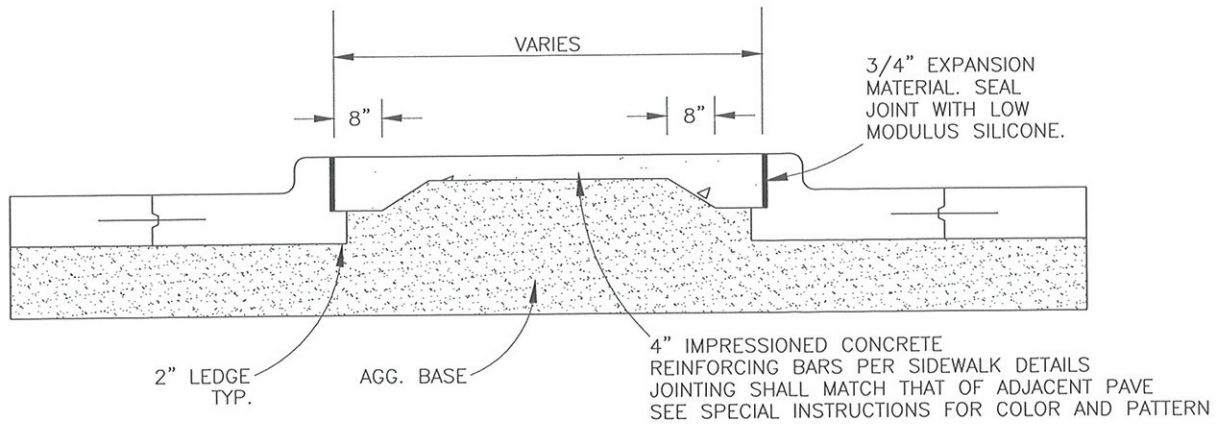

### MEDIAN SECTION

NOTE:  
WHEN OUTFLOW CURB IS SPECIFIED SLOPE WILL BE 3/8" PER FOOT

CURB SECTION WHEN DROPPED FOR DRIVEWAY OR PUBLIC SIDEWALK OPENING. (1.5' TRANSITION CURB FOR SIDEWALK AND DRIVEWAYS)

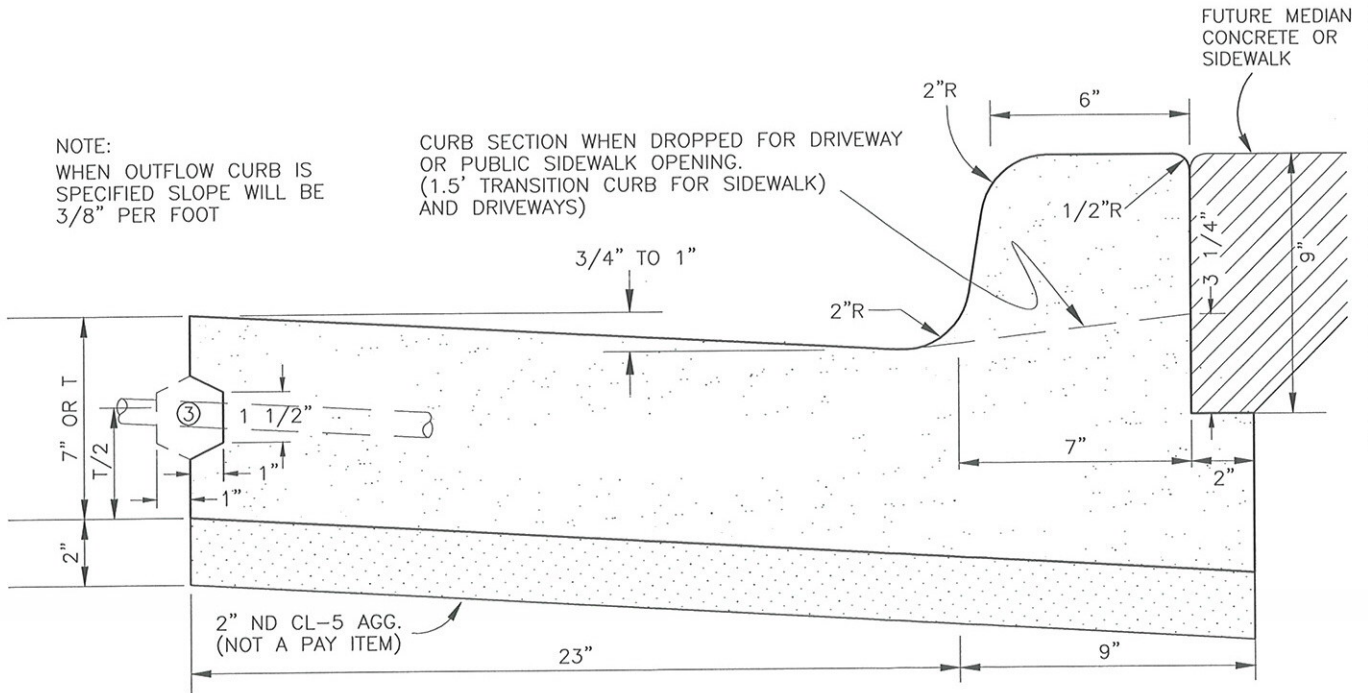

- ③ 1/2"x18" DEFORMED BARS AT 30" O.C. & KEYWAY REQUIRED WHEN SEPARATE CURB IS INSTALLED WITH CONCRETE PAVING

### CURB & GUTTER SECTION

NOTES:

1. DIMENSION T SHALL MATCH THE THICKNESS OF THE ADJOINING CONCRETE WITH EITHER INTEGRAL OR SEPARATE CURB
2. SEE CURB & GUTTER PLAN VIEW ON TYPE II CURB & GUTTER DETAIL FOR CURB & GUTTER JOINTING & REINFORCING
3. PAID FOR AS:  
CURB & GUTTER - STANDARD (TYPE II)

SECTION NO.	2100	DRAWING NO.	5.15
REV.D.	2013		
<b>MEDIAN CONCRETE AND LEDGE CURB &amp; GUTTER</b>			
CITY OF FARGO ENGINEERING DEPARTMENT			
APPROVED	<i>OME</i>	DATE	1-2-13

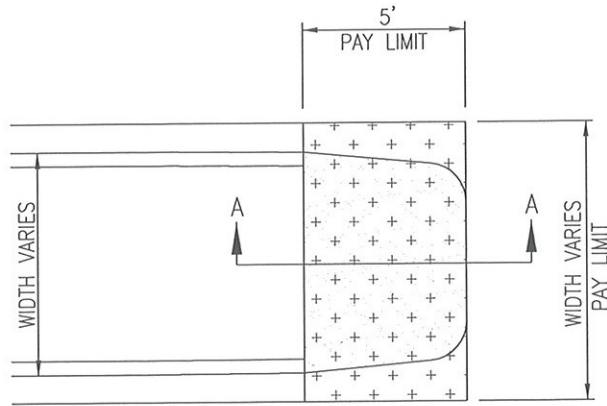

CONCRETE MEDIAN NOSE DETAIL

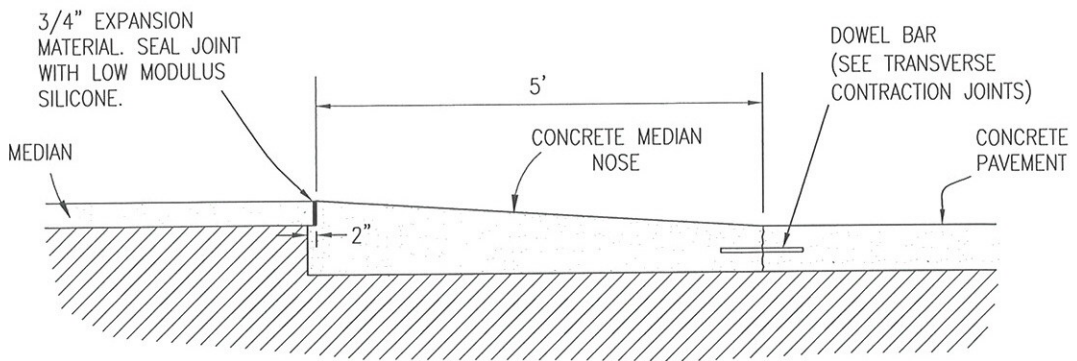

SECTION A-A

NOTE:  
1. PAID AS "MEDIAN NOSE - CONCRETE"

SECTION NO. 2100	DRAWING NO. 5.16
REV.D. 2013	
<b>CONCRETE MEDIAN NOSE DETAIL</b>	
CITY OF FARGO ENGINEERING DEPARTMENT	
APPROVED <i>CME</i>	DATE 1-2-13

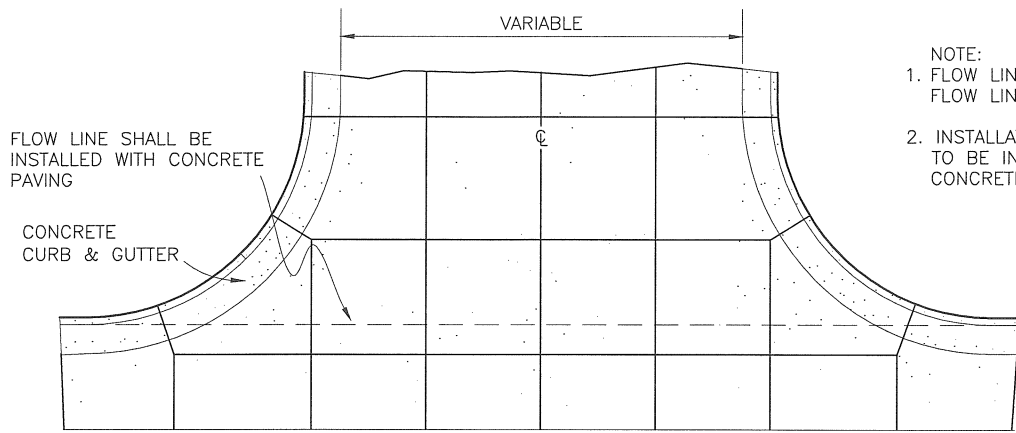

FLOW LINE SHALL BE INSTALLED WITH CONCRETE PAVING

CONCRETE CURB & GUTTER

- NOTE:
1. FLOW LINE TO ALIGN WITH FLOW LINE OF C&G
  2. INSTALLATION OF FLOW LINE TO BE INCIDENTAL TO CONCRETE PAVING ITEM

### CONCRETE STREET SECTION

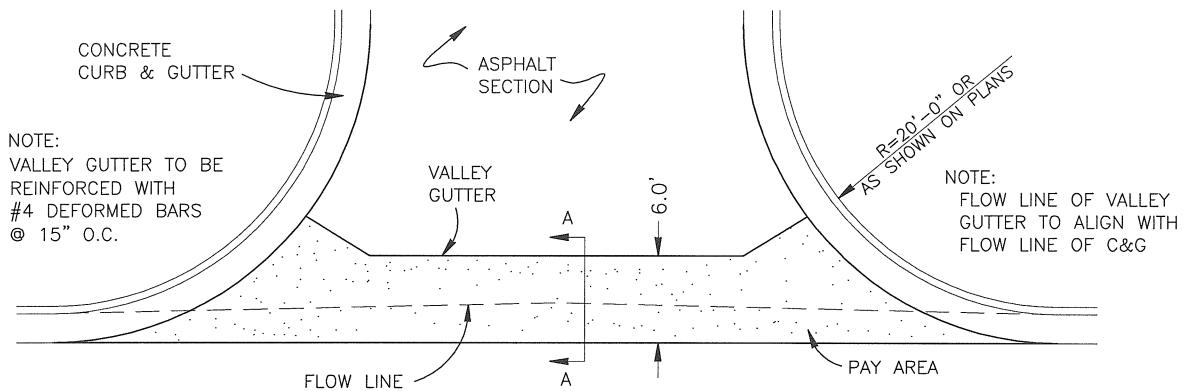

NOTE:  
VALLEY GUTTER TO BE REINFORCED WITH #4 DEFORMED BARS @ 15" O.C.

CONCRETE CURB & GUTTER

ASPHALT SECTION

VALLEY GUTTER

6.0'

R=20'-0" OR AS SHOWN ON PLANS

NOTE:  
FLOW LINE OF VALLEY GUTTER TO ALIGN WITH FLOW LINE OF C&G

FLOW LINE

PAY AREA

### ASPHALT STREET SECTION

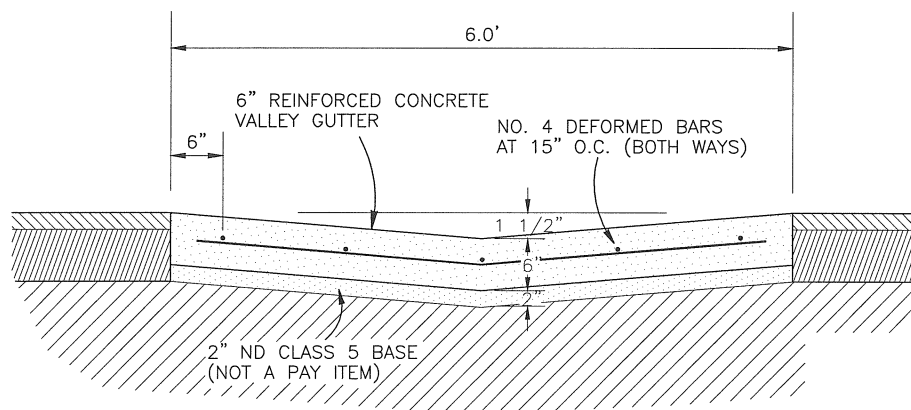

### SECTION A-A

- NOTE:
- (1) AGG. BASE REQUIRED UNDER ENTIRE VALLEY GUTTER (NOT A PAY ITEM)
  - (2) REFER TO PLANS FOR LENGTH OF VALLEY GUTTER

SECTION NO. 2100	DRAWING NO. 5.17
REV.D. 2012	
<b>VALLEY GUTTER DETAIL</b>	
CITY OF FARGO ENGINEERING DEPARTMENT	
APPROVED <i>BEO</i>	DATE <i>2-21-2012</i>

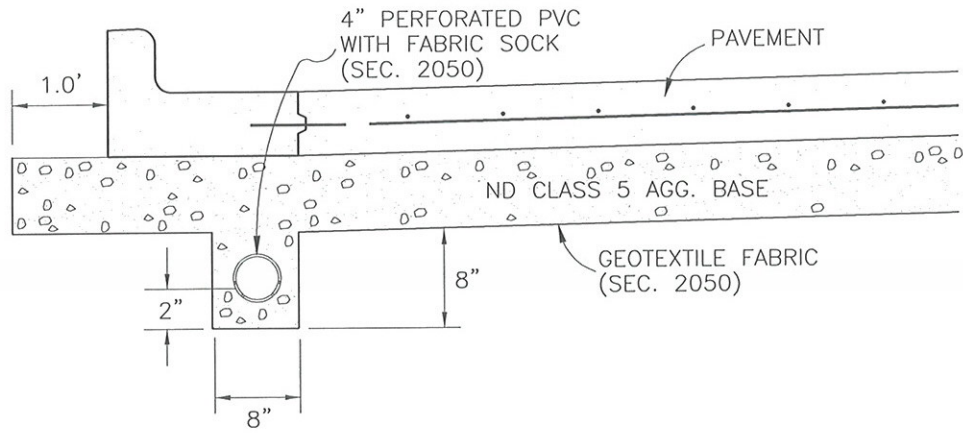

EDGE DRAIN PLACEMENT

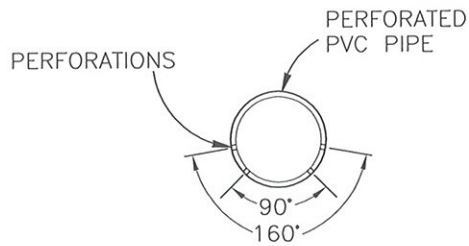

4" PVC PIPE DETAIL

TYPE OF PIPE:

1. The pipe shall be polyvinylchloride SCHEDULE 40 sewer pipe with solvent cemented joints as specified in ASTM Spec. No. F-758.
2. Perforations shall be circular and  $1/4" \pm 1/16"$  in diameter. They should be arranged in rows parallel to the axis of the pipe and shall be spaced approximately 3" center to center along the rows. The spigot end of the pipe shall be unperforated for a length equal to the depth of the socket. The placement and total numbers of the rows shall be as shown above with an allowable tolerance of  $\pm 10"$ .
3. Molded Fittings shall be in accordance with ASTM Spec No. D 2665 or F1866. Cost of fitting and installation to be included in the price bid for 4" PVC Edge Drain.
4. The perforated PVC shall be encased in a Geotextile Fabric per Section 2050. Cost of fabric to be included in the price bid for 4" PVC Edge Drain.
5. PIPE SIZE: 4" diameter IPS SCH 40
6. ROWS OF PERFORATIONS: 4
7. HOLE SIZE: 1/4"
8. HOLE SPACING PER ROW: 3"

NOTES:

1. SEE STORM INLET/PVC DRAIN PIPE DETAIL IN SECTION 1500 FOR ADDITIONAL DETAILS.

SECTION NO. 2100	DRAWING NO. 5.18
REV.D. 2013	
<b>4" PVC EDGE DRAIN DETAIL</b>	
CITY OF FARGO ENGINEERING DEPARTMENT	
APPROVED <i>CME</i>	DATE 1-2-13