

**CITY OF FARGO SPECIFICATIONS  
CONCRETE SIDEWALKS AND DRIVEWAYS**

**PART 1  
DESCRIPTION OF WORK**

The work to be done under this section of the Specifications and the accompanying plans consists of all labor, material, and equipment necessary to construct concrete sidewalks, driveways, and impressed concrete in the City of Fargo according to Municipal Code Article # 18-02 governing the construction of same, which is hereby made a part of this Specification. A copy of the article is attached at the end of this Specification for reference. For the purposes of these Specifications, alley returns shall be considered driveways, and all decorative/colored concrete behind curbs shall be considered impressed concrete.

**PART 2**  
**MATERIAL**

2.1. CEMENT

Cement shall conform to the requirements of Section 2100.

2.2. AGGREGATES

Fine and course aggregates shall conform to the requirements of Section 2100-2.2.

2.3. ADMIXTURES

Any admixtures shall conform to the requirements of Section 2100-2.4.

2.4. CONCRETE PROPORTIONS AND PROPERTIES

One cubic-yard of mixed concrete in place shall contain not less than 517 lbs. of cement at a maximum water/cement ratio of 0.53. The slump shall not exceed four inches. Minimum 28-day compressive strength shall be 4,000 psi. Air content shall be targeted for 6% and shall fall between 5% and 8%.

2.5. REINFORCEMENT

Deformed reinforcing bars conforming to the Standard Specifications for Billet Steel Concrete Reinforcement Bars of the designation ASTM A615. Wire mesh reinforcement shall conform to the Standard Specification for Welded Steel Wire Fabric for Concrete Reinforcement of ASTM.

2.6. EXPANSION MATERIAL

Expansion joint material shall conform to ASTM D-1751 Type 5. It shall be 3/4 inch in thickness and shall have a width equal to the full depth of the slab in which it is to be used.

### 2.7. BASE AND BACKFILL MATERIAL

Base material under the concrete shall meet the gradation requirements of N.D. Class 5. Fill placed against the sides of the sidewalk shall be topsoil conforming to the requirements of Section 2000 of these Specifications.

### 2.8. FORMS

Forms shall be metal or wood free from warp and of sufficient strength to resist springing during the process of placing the concrete against them. Wood forms shall be at least 1 1/2 inch thick except for sharply curved sections where a flexible material shall be used with the Engineer's approval. Metal forms shall have a flat top and shall be of an approved section. Forms shall be of a depth equal to the sidewalk or driveway and shall be securely braced to retain the correct line and grade. Forms should be thoroughly cleaned and oiled or wetted before concrete is placed against them and be sufficiently tight to prevent mortar leakage between them.

### 2.9. STAMP

Stamp shall consist of letters 1 1/4 inches high and of sufficient depth to imprint the concrete to the depth of 1/8 inch. The stamp shall have the Contractor's name and the year of construction.

### 2.10. DETECTABLE WARNING PANELS

The detectable warning panels shall be either Engineered polymer composite panels or cast-iron panels as described below:

#### *2.10.1. CAST IRON PANELS*

Intended for use downtown and where specified by the Engineer in the plans. Panels shall be cast-in-place, powder-coated federal color FS 30166 (brick red), manufactured by East Jordan Iron Works, Neenah Foundry, or approved equal.

*2.10.2. ENGINEERED POLYMER COMPOSITE PANELS*

Intended for use on all projects where cast iron panels are not specified. Panels shall be cast-in-place, skid resistant, non-glare finished, and have a UV stable homogeneous integral color - federal color FS 33538 (safety yellow). Acceptable products are “Armor-Tile” as manufactured by Engineered Plastics, Inc., “Access Tile” as manufactured by Access Products, Inc., “Replaceable Wet-Set” as manufactured by ADA Solutions, Inc., or approved equal.

*2.10.3. TRUNCATED DOME CONFIGURATION*

The detectable warning panel shall consist of surface of truncated domes aligned in a square grid pattern.

Dome Size – Truncated domes in a detectable warning surface shall have a base diameter of 0.9 inches minimum to 1.4 inches maximum, a top diameter of 50% of the base diameter minimum to 65% of the base diameter maximum, and a height of 0.2 inches.

Dome Spacing – Truncated domes in a detectable warning surface shall have a center-to-center spacing of 1.6 inches minimum and 2.4 inches maximum, and a base-to-base spacing of 0.65 inches minimum measured between the most adjacent domes on the square grid.

Size – Detectable warning surfaces shall extend 24 inches in the direction of travel and the full width of the curb ramp landing.

Friction – Panels shall have a minimum coefficient of friction of 0.80.

*2.11. CURING COMPOUND*

All curing compounds shall conform to the requirements of AASHTO M 148 Type 2, and shall be applied in accordance with the manufacturer’s recommendations.

*2.11.1. SIDEWALKS AND DRIVEWAYS*

White pigmented in color.

2.11.2. *IMPRESSIONED CONCRETE*

Transparent (no color).

**PART 3**  
**CONSTRUCTION**

3.1. ALIGNMENT AND GRADE

Prior to the construction or reconstruction of the sidewalk or driveway, the Contractor shall request the Engineer to set line and grade for the construction. Where necessary, the Engineer shall provide offset line stakes, which will be placed on each property corner and at interim intervals as necessary. Stakes will be offset and indicate the location and grade of the sidewalk or driveway to be constructed. Sidewalk shall have a 1/4-inch drop per foot across the width of the walk with the property side being higher than the street side.

3.2. EXCAVATION

The excavation for sidewalks, driveways, and impressed concrete shall be performed in a manner as to leave any finished lawn and boulevard in good condition and so as to protect any trees or shrubs adjacent to the work. The excavation shall be to a minimum depth of two inches below the bottom of the slab to be poured. If no excavation is required, all vegetation shall be removed in the area below the slab. No sidewalk subbase shall be constructed on any surface that is sloping to such an extent as to cause a future sliding or shifting of the finished work. Such slopes shall be benched or excavated to a horizontal plane before the subbase is constructed.

Excavated material not used at the site and not desired by the property owner shall be disposed of as directed by the City Engineer.

3.3. REMOVAL OF OLD SIDEWALK

Removal of old sidewalk will be required - the old concrete shall not be left in place beneath the new concrete. Removals shall be per Section 1050 of these Specifications.

3.4. REMOVAL OF CURBS FOR DRIVEWAYS

Existing curbs shall be removed for the construction of driveways. Removals shall be per Section 1050 of these Specifications.

### 3.5. PREPARATION OF THE SUBGRADE

All soft spongy spots or other unsuitable material shall be removed and replaced with suitable material and the subgrade compacted to a firm uniform surface.

### 3.6. PREPARATION OF THE SUBBASE

The aggregate subbase material shall be placed between the forms and compacted to a firm uniform surface by means of a hand tamper or vibratory compactor, then leveled off to the proper grade.

### 3.7. REINFORCING STEEL

All bars and/or mesh shall be clean and rust free and shall be supported at mid-depth by “chairs” of a type approved by the Engineer. Reinforcement bars shall be drilled into existing concrete.

#### A. SIDEWALK AND IMPRESSIONED CONCRETE REINFORCEMENT

Two 3/8 inch deformed reinforcing bars shall be placed longitudinally for the full length of the sidewalk, said bars being placed one foot in from the edge of the form, and tied to the transverse bars. One 3/8 inch bar shall be placed one foot on either side of all expansion and contraction joints, said bar being 6 inches shorter than the width of the slab in which it is placed. Sidewalks over vaults or other openings shall be constructed to carry a load of not less than 250 pounds per square foot.

Reinforcement for sidewalk wider than 4 ½ feet shall be #3 bars at 24” on center. Welded wire mesh may be used on sidewalk wider than six feet in width. The wire mesh shall be cut into panels six inches smaller than the panel in which it is to be placed, but shall not extend through any contraction or expansion joint. Welded wire mesh shall be 6x6 W1.4/1.4 or heavier.

Two additional 3/8 inch reinforcement bars at least 10 feet long shall be placed in sidewalks over sewer and water trenches. Tie-ins to existing sidewalks shall have two 3/8” smooth bars drilled into the existing slab with a greased and capped end installed in the new sidewalk slab.

**B. DRIVEWAY REINFORCEMENT**

Reinforcement for driveways shall consist of #4 deformed bars spaced 24 inches on center both ways.

**3.8. DIMENSIONS OF SLABS**

Sidewalk shall be a minimum of 4 inches thick, residential driveways and alley returns shall be a minimum of 6 inches thick, and commercial and industrial driveways shall be a minimum of 7 inches thick. Sidewalk thickness shall be no less than the adjoining drive or 6 inches, whichever is greater, when located within a driveway section.

Sidewalks shall be a minimum of 4.5 feet wide and no sidewalk shall be reconstructed to a width less than that existing prior to reconstruction. Should occupancy of a commercial property change so as to substantially increase pedestrian traffic, the City Engineer shall require the sidewalk to be widened to conform to the sidewalks in the surrounding area.

Residential driveways shall be no less than 9 feet wide or more than 30 feet wide at the sidewalk line. Maximum width for commercial or industrial driveways is forty feet. Driveways shall be located so as to provide access to a parking location within the property served. Upon approval from the City Engineer, residential driveways may be constructed to a maximum 36-foot width or one-half the width of the lot. Locations of said driveways near block corners shall be approved by the City Engineer and shall be in accordance with the Fargo Land Development Code. In no case shall the aggregate width of a driveway into a property exceed one-half the lot width.

**3.9. PLACING OF CONCRETE**

All concrete shall be placed using formwork unless a mechanical paver is used. The subbase shall be moistened immediately prior to placing the concrete. The concrete shall be placed on the moist subbase and spread uniformly with as little handling as possible. The concrete shall be rough finished with a mechanically vibrated screed assembly and shall be spaded or vibrated with hand vibrators next to the forms to prevent voids or honeycomb surfaces.

**3.10. CONTRACTION JOINTS**

Contraction joints shall be constructed so as to divide the sidewalk into square slabs the greatest horizontal dimension of which shall not exceed 6 feet. All joints shall be saw cut on all sidewalk



six feet or wider. Driveways shall have sawed contraction joints transversely spaced evenly between the crossing plate and the curb, not to exceed 8', and longitudinally spaced evenly across the driveway, not to exceed 12'. The contraction joints on sidewalk less than 6 feet wide shall be cut with a pointed trowel and edged to a radius of 1/2 inch, or sawed to a depth of 1/3 the depth of the slab within 24 hours of being placed.

### 3.11. EXPANSION JOINTS

Expansion joints in sidewalks shall be placed at 250-foot intervals, driveway edges, at every property corner and along existing curbs abutting the sidewalk or as directed by the Engineer. Greased 3/8" smooth bars shall be placed at mid-depth six (6) inches in from each sidewalk edge through the expansion joint. All expansion joints along curbs shall be 3/4 inch (shown on details) wide. All expansion joints shall be sealed with low modulus silicone sealant to produce a slightly concave surface approximately 1/4 inch below the concrete surface.

### 3.12. FINISHING

Immediately after placing, the concrete shall be floated down to a uniformly dense surface. The concrete surface shall have a slightly rough wood-float finish or a light broom finish. No apparent surface defects shall be allowed.

### 3.13. A.D.A. CURB RAMPS

Sidewalk curb approach ramps shall be constructed to current A.D.A. standards as detailed in the plans.

#### A. DETECTABLE WARNING PANELS

All panels shall be installed according to the manufacturer's recommendations. Protective plastic shall be removed prior to opening the ramp to public use.

Dome Alignment – The rows of truncated domes in a detectable warning surface shall be aligned to be perpendicular to the grade break of the curb ramp.

Rail Crossings – The detectable warning surface shall be located so that the edge nearest the rail crossing is 6 feet minimum and 15 feet maximum from the centerline of the

nearest rail. The rows of the truncated domes in the detectable warning surface shall be aligned with the direction of wheelchair travel.

**B. SLOPE**

1) **NEW CONSTRUCTION**

Maximum slope shall be 1 foot vertical to 12 feet horizontal. Maximum rise for any run shall be thirty (30) inches or less.

2) **RECONSTRUCTION**

Curb ramps reconstructed where space limitations prevent the use of 1:12 slopes may have the following:

- a) Slopes between 10 and 12 to 1 are allowed a maximum rise of 6 inches.
- b) Slopes between 8 and 10 to 1 are allowed for a maximum rise of 3 inches.
- c) Slopes greater than 8 horizontal to 1 vertical are not allowed.

3) **SIDE SLOPE**

When curb ramps are located where pedestrians must walk across the ramp, the ramp shall have flared sides with a maximum slope of 1-foot vertical to 10 feet horizontal.

**3.14. STAMPING**

The Contractor shall stamp the name of his firm and year of construction into the fresh concrete on both sides of all expansion joints and at all termination points.

**3.15. SIDE FILL REQUIRED**

The Contractor will be required to backfill against the sides of the sidewalk and driveways to the top of the walk or drive and sloping away from the walk or drive at a grade no steeper than 1 foot vertical to 4 feet horizontal.

**3.16. IMPRESSIONED CONCRETE**

The Engineer will specify the concrete color and pattern in the plans and/or special instructions.

Reinforcing shall be per the sidewalk reinforcing Specifications above. Where impressed concrete abuts sidewalk, they shall be tied together with 12" long #3 deformed bars at 2' O.C.

Concrete finishing shall follow normal procedures for sidewalk except that the surface shall not be troweled more than once. After the surface is troweled or floated, and the concrete is still in a plastic stage, a pattern roller/stamp shall be used to obtain the specified pattern. The roller/stamp shall be placed so that the pattern is accurately aligned and to obtain a uniform depth of stamp of 5/16 inch. After rolling, a tool similar to a brick mason's jointer shall be used to dress the edges. Transverse and longitudinal joints shall be sawed in locations to match joints in abutting concrete or as determined by the Engineer.

Sandblasting shall be done by the Contractor to clean any colored concrete from the roadway and/or curb and gutter surfaces

Impressed concrete shall be 4 inches thick in medians and boulevards, and shall be 8 inches thick inside curb radii at intersections or as directed by the Engineer.

Refer to the standard details for thickened edge, expansion joint, and joint sealing requirements.

### 3.17. CURING AND PROTECTION OF SLABS

The Contractor shall cure the concrete by covering as soon as practicable with waterproof paper, plastic film, wet burlap, or by spraying with an approved curing agent. The Contractor shall erect suitable barriers, protected by warning lights to protect the work and the public. The Contractor is responsible for all damage and repair to the slabs. Sidewalks shall be closed to pedestrian traffic for a minimum of 24 hours and crossings and driveways shall be closed to vehicular for a minimum of seven days. The Contractor shall use due care when removing the forms to avoid marring or damaging the fresh concrete.

### 3.18. WORKZONE SAFETY

Provisions protecting pedestrians and the traveling public in the workzone shall be employed in all cases per section 4100 of these Specifications.

**PART 4****GUARANTEE, MEASUREMENT & PAYMENT****4.1. GUARANTEE**

The guarantee shall be per the contract.

**4.2. MEASUREMENT AND PAYMENT**

Payment will be full compensation for the excavation, subgrade and subbase preparation, furnishing and installing the aggregate base, concrete, reinforcing, expansion joints including sealant where specified, form work and all incidental labor, material, and equipment necessary to construct the sidewalks, driveways, and impressed concrete in accordance with these Specifications.

**4.2.1. SIDEWALKS AND DRIVEWAYS**

Sidewalks and driveways will be paid at the contract unit price per square yard.

**4.2.2. CITY ORDER SIDEWALK**

At the completion of each sidewalk constructed on city order, the Contractor shall measure the material and work involved, he shall then complete the estimate form provided, and shall forward the duplicate to the City Engineer for verification and payment.

**4.2.3. A.D.A. CURB RAMPS**

Payment for the curb ramp constructed shall be at the contract unit price for each of the following:

- A. Detectable Warning Panels – Panels shall be paid at the contract unit price per square foot.
- B. The remaining portion of the curb ramp shall be paid for under the 6” RC Sidewalk bid item at the contract unit price per square yard.

*4.2.4. IMPRESSIONED CONCRETE*

Impressioned Concrete will be paid at the contract unit price per square yard. Payment for impressioned concrete shall be made under the Impressioned Concrete bid item for the appropriate thickness. No adjustments will be made for thickened edges adjacent to curbs.

*4.2.5. OTHER COSTS*

All other costs for work necessary to properly complete the work specified herein shall not be bid items; the costs shall be charged to other items unless a bid item is specifically included on the bid sheet.

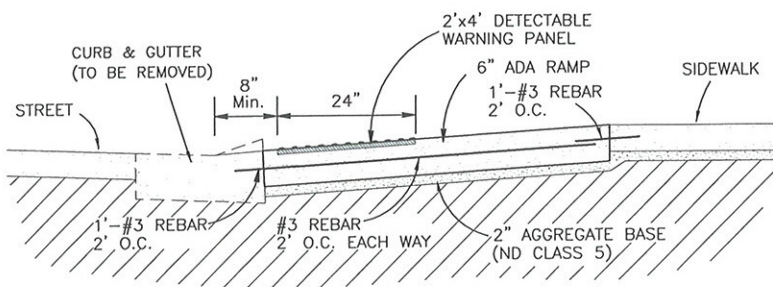
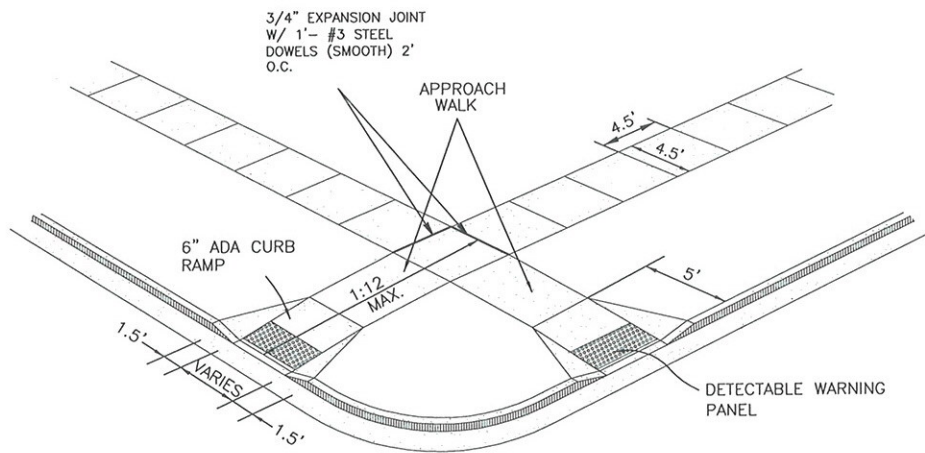
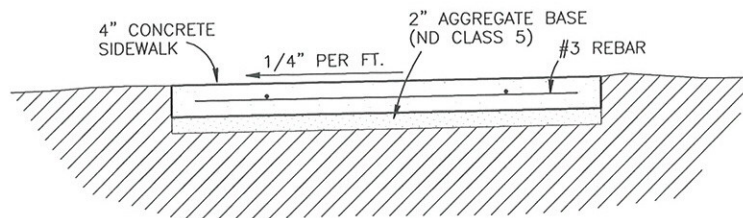
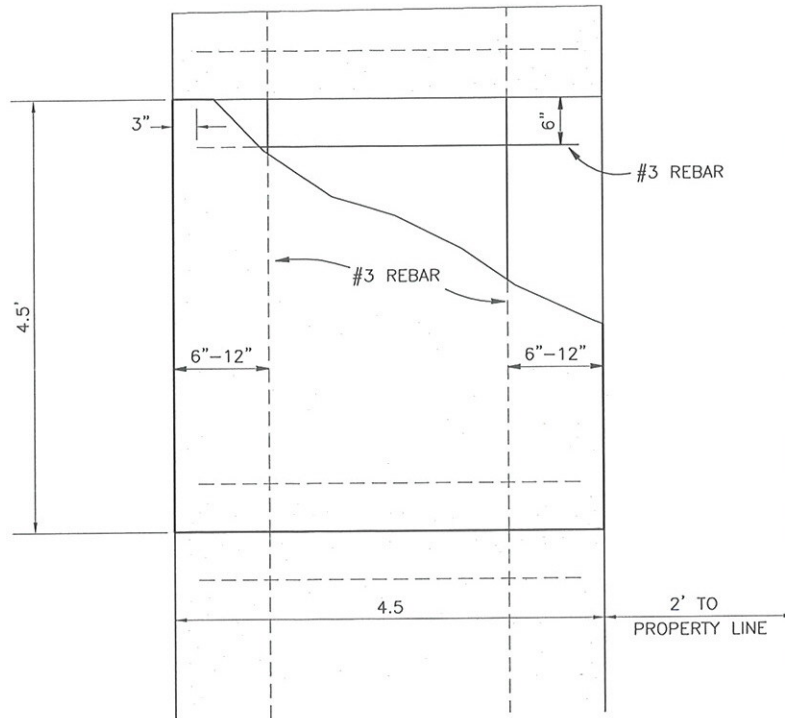

SECTION NO.	2300	DRAWING NO.	5.1
REV.D.	2013		
<b>SIDEWALK &amp; CURB RAMP DETAIL (4.5')</b>			
CITY OF FARGO ENGINEERING DEPARTMENT			
APPROVED	<i>CME</i>	DATE	1-2-13

SIDEWALK WIDTH	PANELS (L'xW')
6'	5'x6'
8'	4.5'x4'
10'	5'x5'

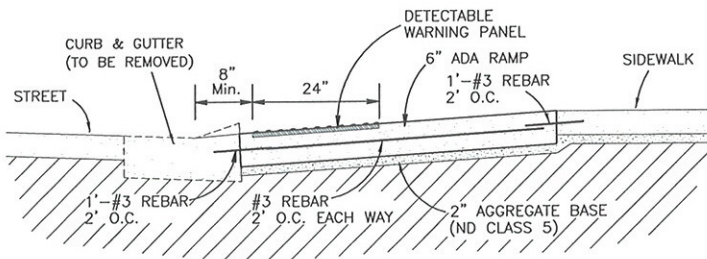
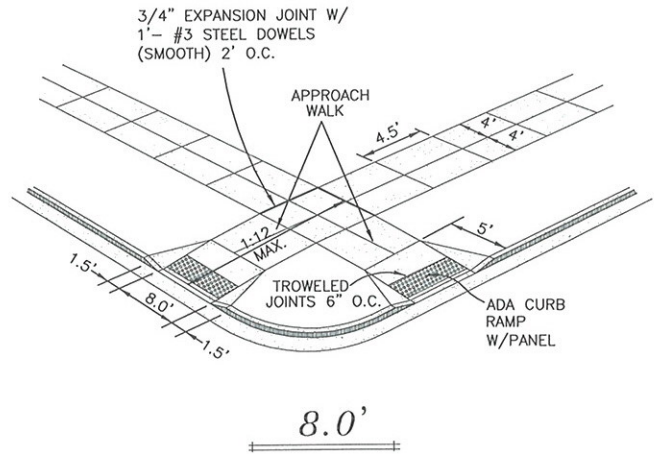
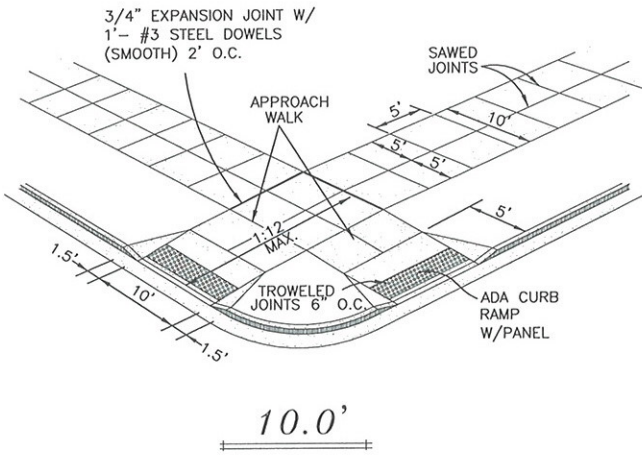
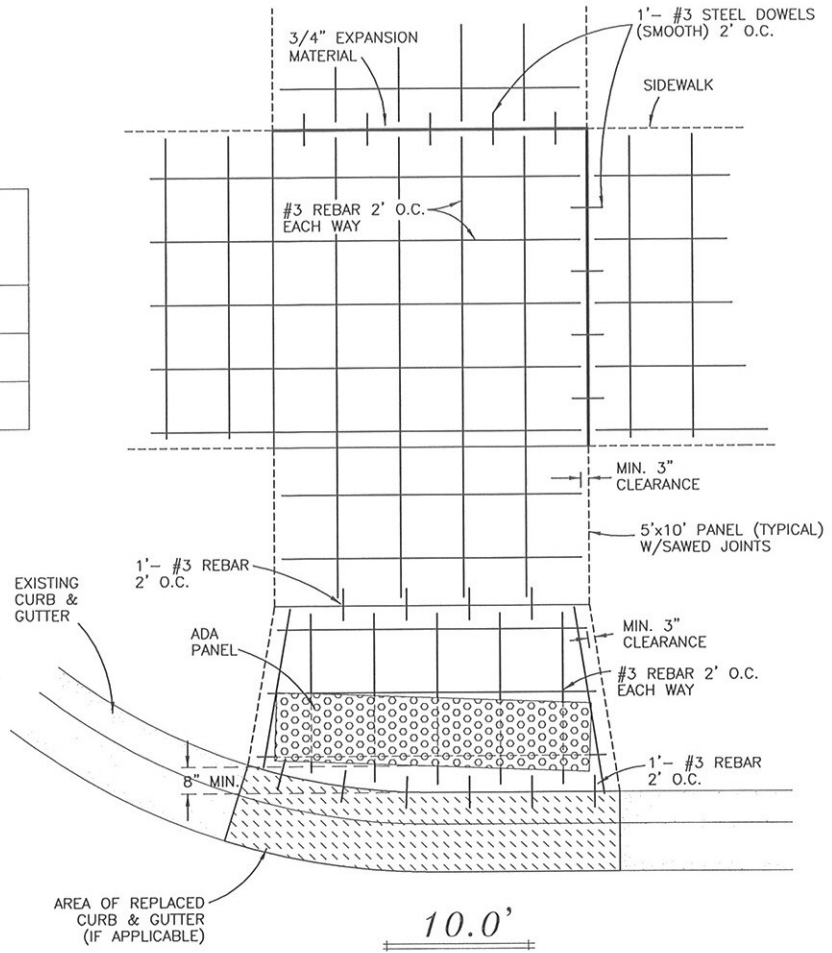

SECTION NO. 2300	DRAWING NO. 5.2
REV.D. 2013	
<b>SIDEWALK &amp; CURB RAMP DETAIL</b> (6', 8', or 10')	
CITY OF FARGO ENGINEERING DEPARTMENT	
APPROVED <i>CME</i>	DATE 1-2-13

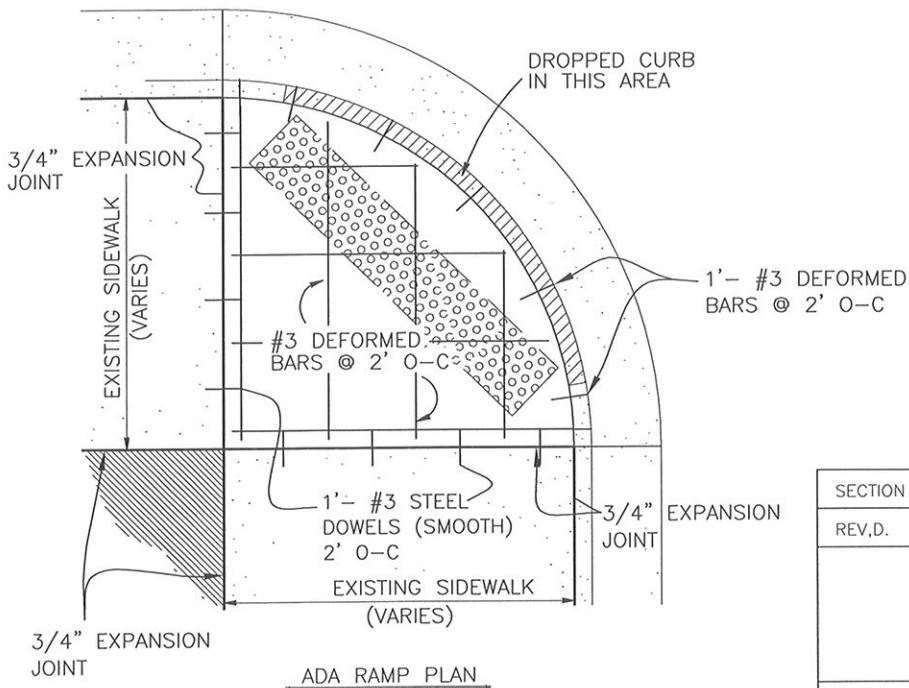
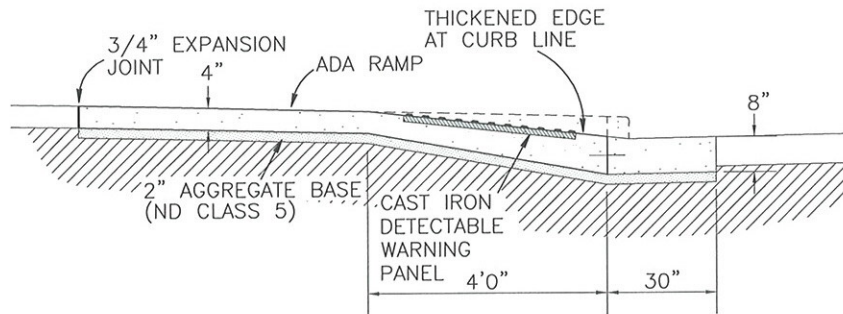
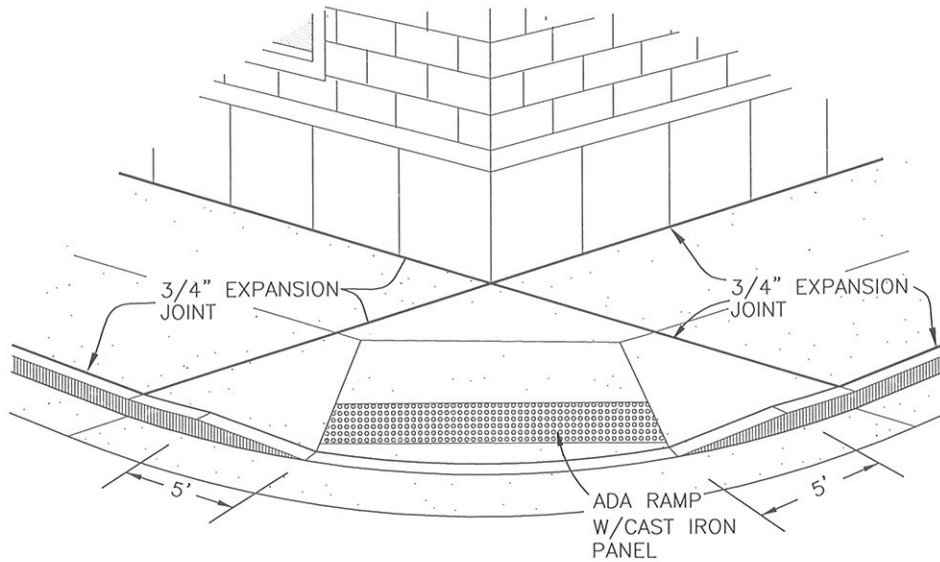

SECTION NO.	2300	DRAWING NO.	5.3
REV.D.	2013		
<b>ADA RAMP DOWNTOWN AREA</b>			
CITY OF FARGO ENGINEERING DEPARTMENT			
APPROVED	<i>CME</i>	DATE	<i>1-2-13</i>



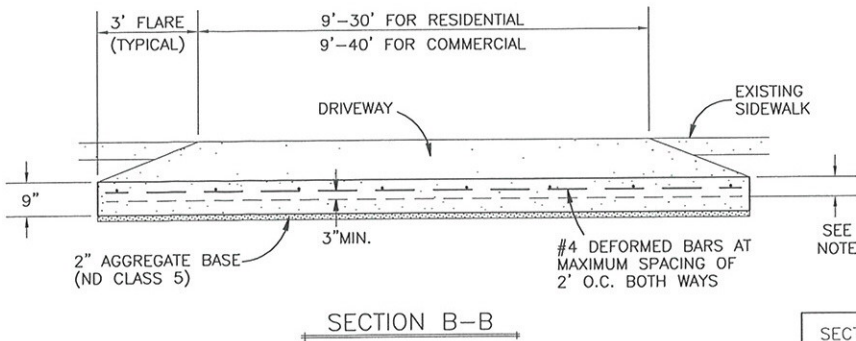
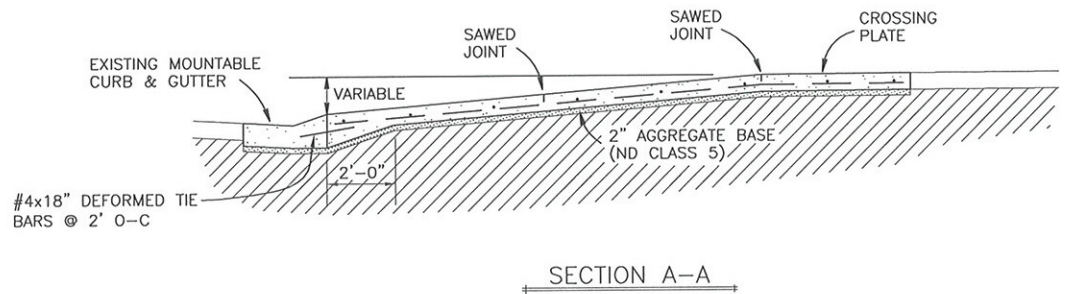
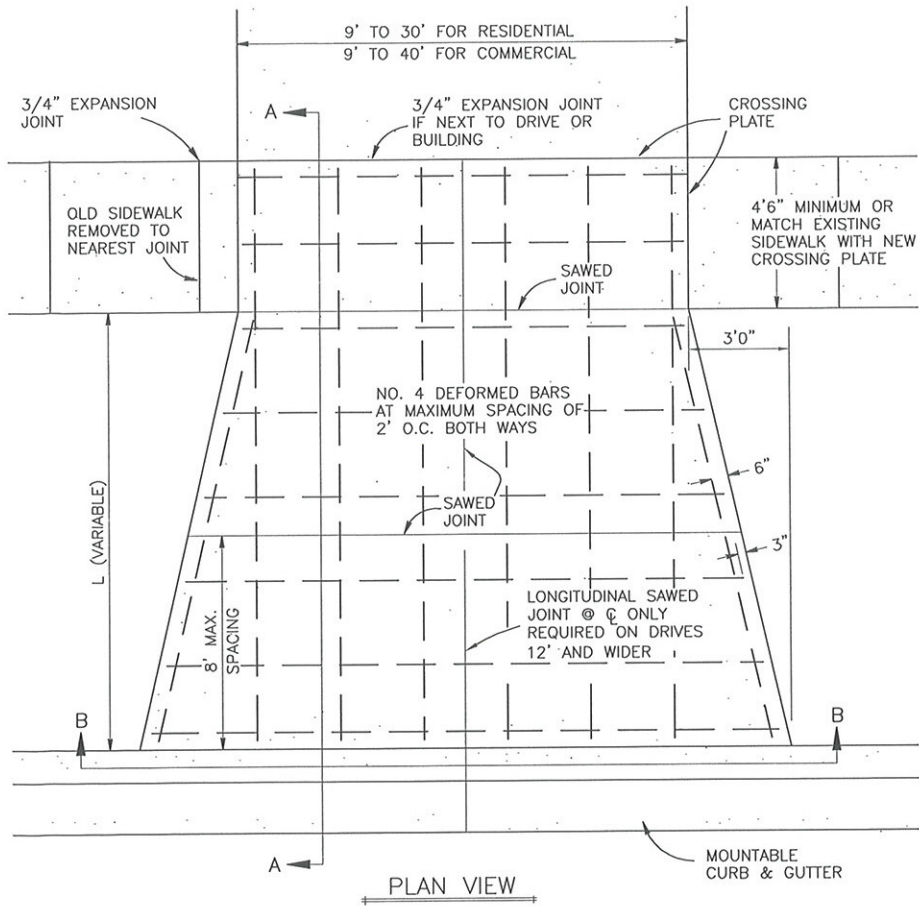

- NOTES:
1. MIN. THICKNESS OF DRIVEWAYS SHALL BE:  
6" FOR RESIDENTIAL  
7" FOR COMMERCIAL AND INDUSTRIAL
  2. JOINT SPACINGS: THE DRIVEWAY LONGITUDINAL JOINT SPACING SHALL MATCH CURB AND GUTTER OR CONCRETE PAVEMENT JOINT SPACING. THE DRIVEWAY TRANSVERSE JOINT SPACING SHALL NOT EXCEED 8' SPACING.
  3. SAW DEPTH: THICKNESS/4 + 1/4"

SECTION NO. 2300	DRAWING NO. 5.4
REV.D. 2013	
<b>STANDARD PRIVATE DRIVE ABUTTING MOUNTABLE CURB</b>	
CITY OF FARGO ENGINEERING DEPARTMENT	
APPROVED <i>OME</i>	DATE 1-2-13

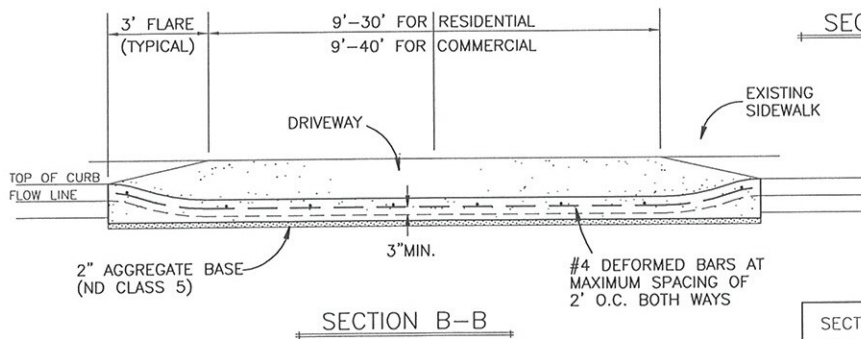
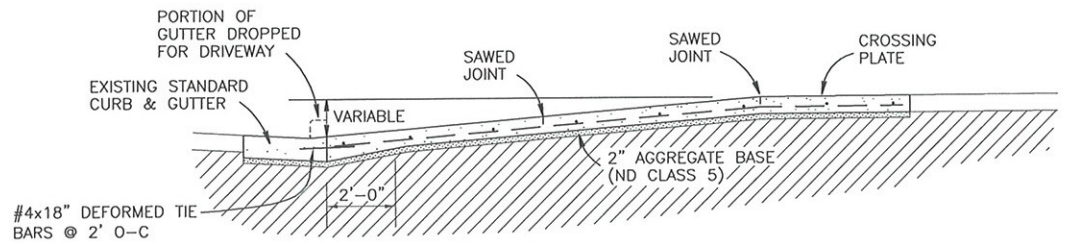
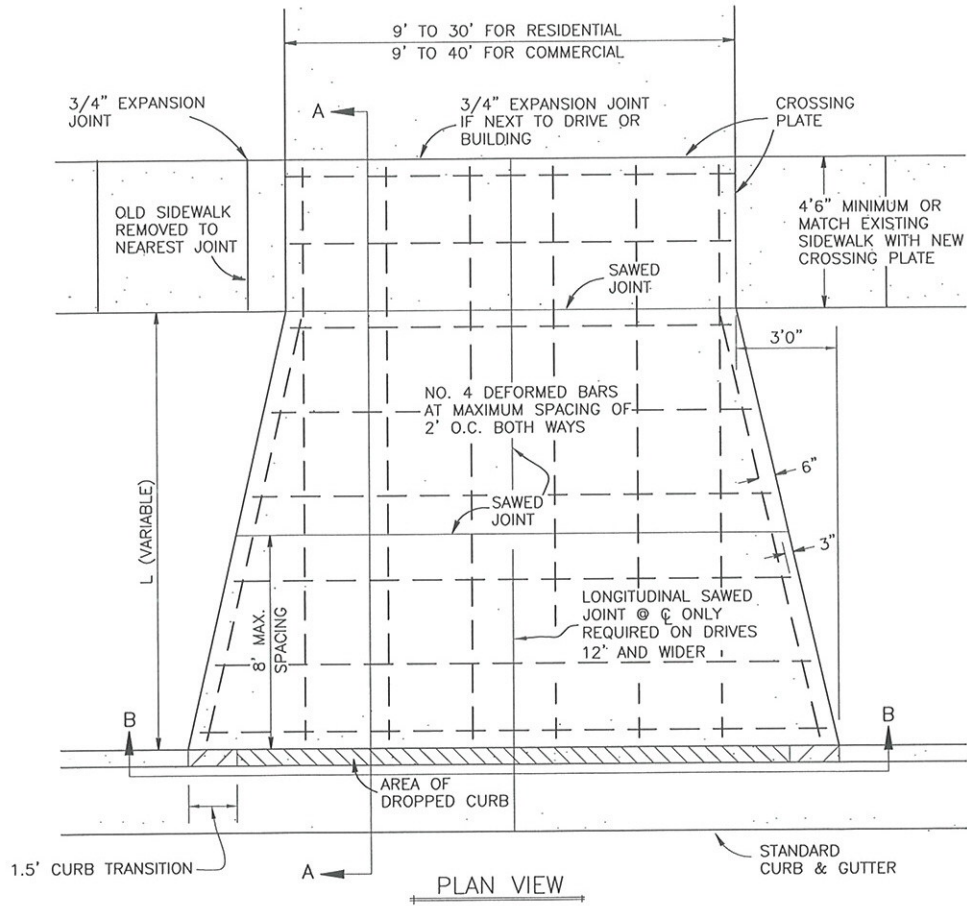

- NOTES:
1. MIN. THICKNESS OF DRIVEWAYS SHALL BE:  
6" FOR RESIDENTIAL  
7" FOR COMMERCIAL AND INDUSTRIAL
  2. JOINT SPACINGS: THE DRIVEWAY LONGITUDINAL JOINT SPACING SHALL MATCH CURB AND GUTTER OR CONCRETE PAVEMENT JOINT SPACING. THE DRIVEWAY TRANSVERSE JOINT SPACING SHALL BE EVENLY SPACED BETWEEN THE CROSSING PLATE AND CURB, NOT TO EXCEED 8' SPACING.
  3. SAW DEPTH: THICKNESS/4 + 3/4"

SECTION NO. 2300	DRAWING NO. 5.5
REV.D. 2013	
<b>STANDARD PRIVATE DRIVE ABUTTING STANDARD CURB</b>	
CITY OF FARGO ENGINEERING DEPARTMENT	
APPROVED <i>CME</i>	DATE 1-2-13

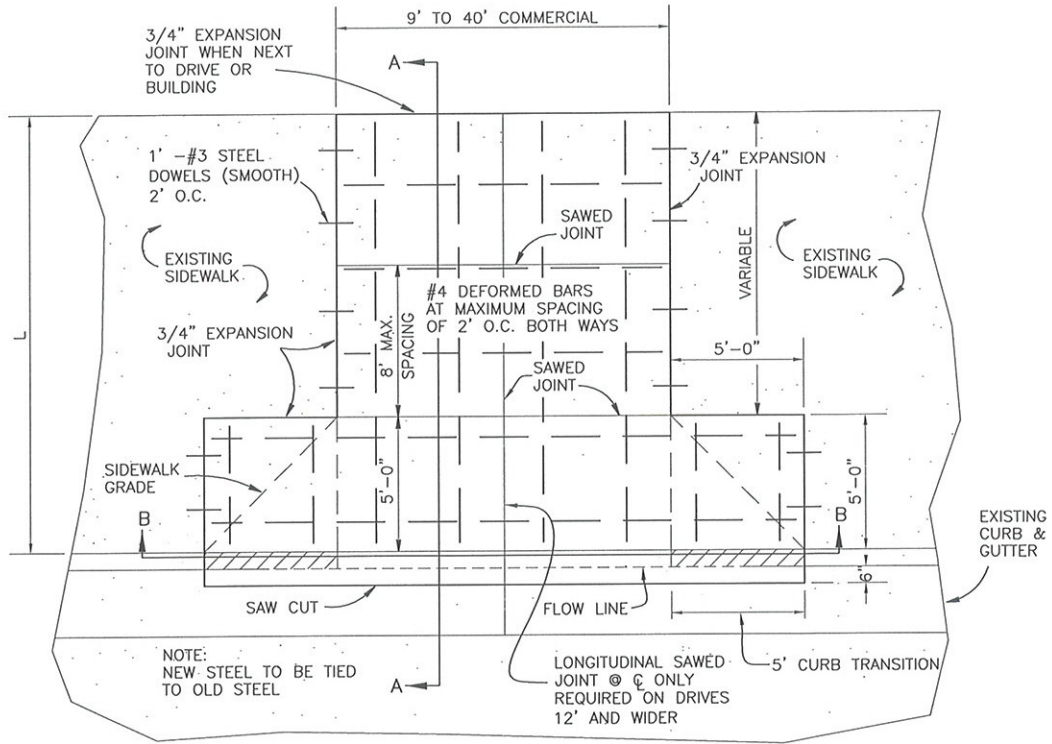

PLAN VIEW

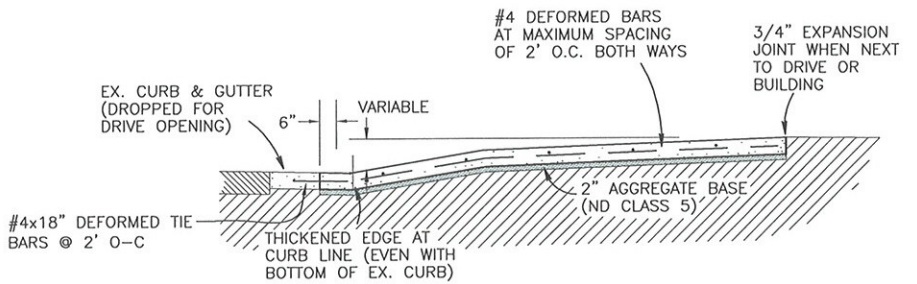

SECTION A-A

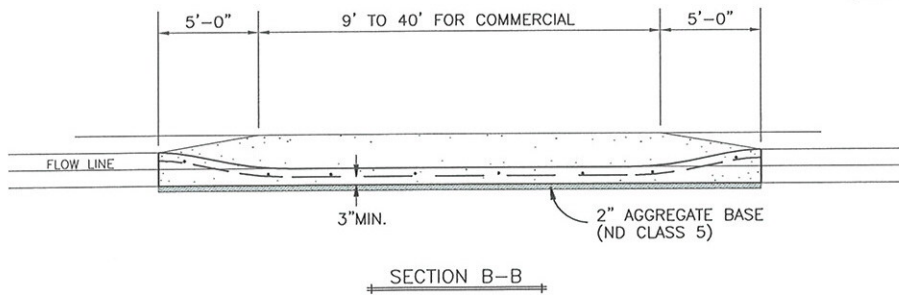

SECTION B-B

- NOTES:
1. MIN. THICKNESS OF DRIVEWAYS SHALL BE:  
6" FOR RESIDENTIAL  
7" FOR COMMERCIAL AND INDUSTRIAL
  2. JOINT SPACINGS: THE DRIVEWAY LONGITUDINAL JOINT SPACING SHALL MATCH CURB AND GUTTER OR CONCRETE PAVEMENT JOINT SPACING. THE DRIVEWAY TRANSVERSE JOINT SPACING SHALL MATCH EXISTING SIDEWALK JOINTS.
  3. SAW DEPTH: THICKNESS/4 + 1/4"

SECTION NO. 2300	DRAWING NO. 5.6
REV.D. 2013	
<b>RETROFIT PRIVATE DRIVE W/FULL SIDEWALK</b>	
CITY OF FARGO ENGINEERING DEPARTMENT	
APPROVED <i>OME</i>	DATE 1-2-13

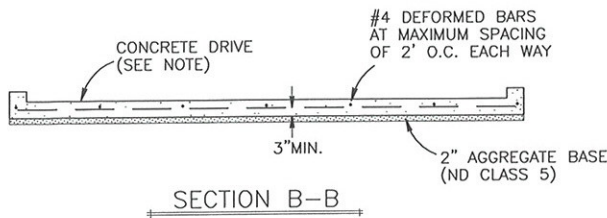
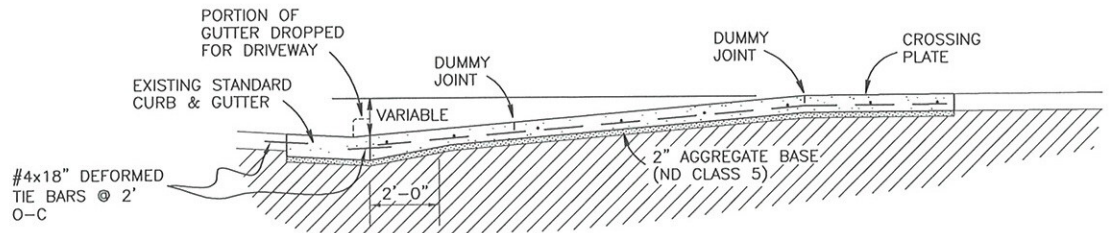
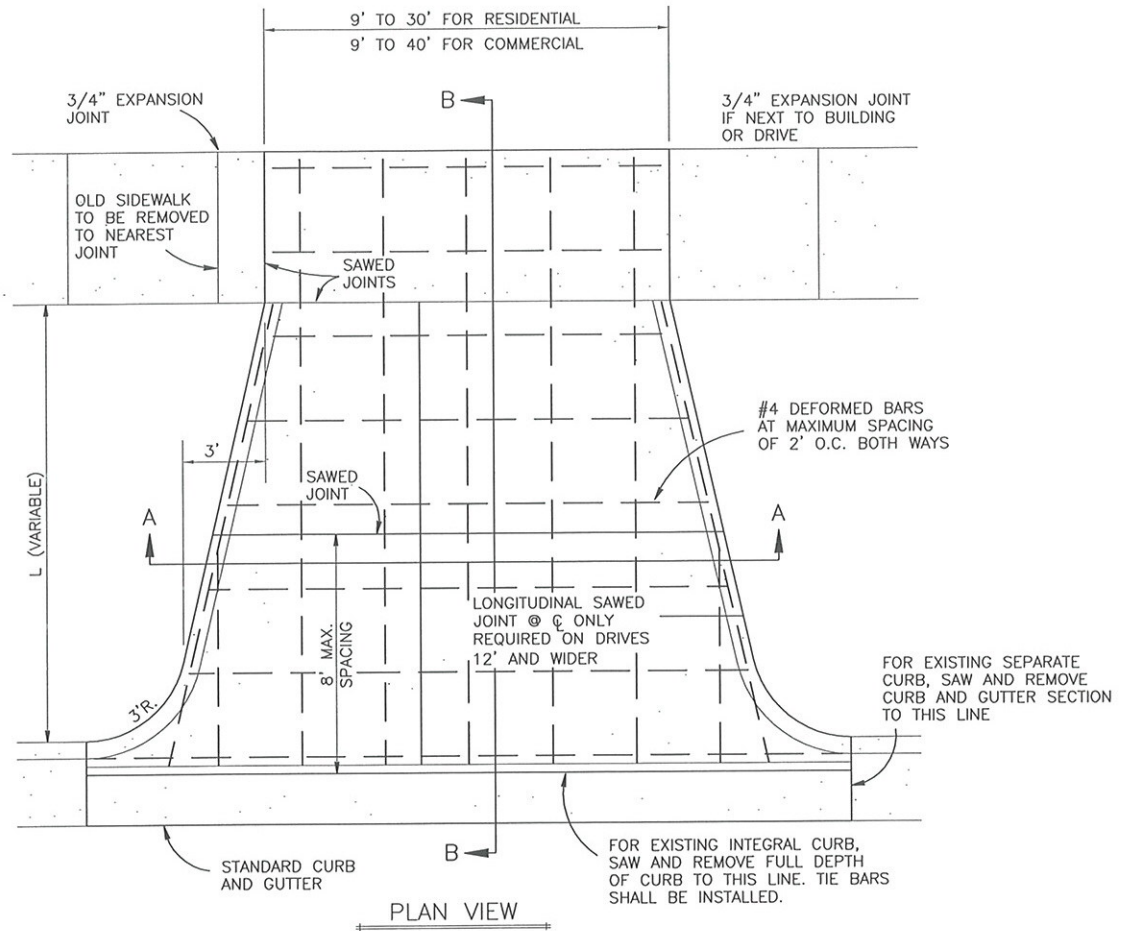

**NOTES:**

1. MIN. THICKNESS OF DRIVEWAYS SHALL BE:  
6" FOR RESIDENTIAL  
7" FOR COMMERCIAL AND INDUSTRIAL
2. JOINT SPACINGS: THE DRIVEWAY LONGITUDINAL JOINT SPACING SHALL MATCH CURB AND GUTTER OR CONCRETE PAVEMENT JOINT SPACING. THE DRIVEWAY TRANSVERSE JOINT SPACING SHALL BE EVENLY SPACED BETWEEN THE CROSSING PLATE AND CURB, NOT TO EXCEED 8' SPACING.
3. SAW DEPTH: THICKNESS/4 + 1/4"
4. THIS DRIVEWAY DETAIL NOT TO BE USED FOR NEW CONST. UNLESS SPECIFICALLY DIRECTED BY THE ENGINEER.

SECTION NO. 2300	DRAWING NO. 5.7
REV.D. 2013	
<b>STANDARD PRIVATE DRIVE ABUTTING STANDARD CURB</b>	
CITY OF FARGO ENGINEERING DEPARTMENT	
APPROVED <i>CME</i>	DATE 1-2-13