

FARGO CITY COMMISSION AGENDA
Monday, October 23, 2017 - 5:00 p.m.

City Commission meetings are broadcast live on TV Fargo Channel 56 and online at www.FargoND.gov/streaming. They are rebroadcast Mondays at 5:00 p.m., Thursdays at 7:00 p.m. and Saturdays at 8:00 a.m. They are also included in the video archive at www.FargoND.gov/citycommission.

- A. Pledge of Allegiance.
- B. Roll Call.
- C. Approve Order of Agenda.
- D. Minutes (Regular Meeting, October 9, 2017).

CONSENT AGENDA – APPROVE THE FOLLOWING:

- 1. Waive requirement to receive and file an Ordinance one week prior to 1st reading and 1st reading of an Ordinance Amending Section 20-0401 of Article 20-04 of Chapter 20 of the Fargo Municipal Code Relating to Use regulations.
- 2. Receive and file Third Quarter Financial Status Report for Major Operating Funds through September 30, 2017.
- 3. Receive and file General Fund – Budget to Actual through September 30, 2017 (unaudited).
- 4. Applications for Games of Chance:
 - a. Red River Children’s Advocacy Center for a raffle and raffle board on 11/16/17.
 - b. United Way of Cass-Clay for a raffle on 10/27/17
 - c. American Legion Auxiliary for a raffle on 7/1/18.
 - d. HeartSprings Community Healing Center for a raffle on 12/5/17.
 - e. Pink It Forward for bingo from 11/22/17 to 4/1/18.
 - f. Centennial Elementary PTO for bingo from 10/27/17 to 5/31/18.
 - g. United Way of Cass-Clay for a raffle board on 11/2/17.
 - h. Handi-Wheels Transportation, Inc. for a raffle on 12/12/17.
 - i. Fargo Angels Hockey for a raffle board on 12/3/17.
- 5. Tax exemptions for improvements made to buildings:
 - a. Kevin and Deann M. Pladson, 172 North Woodcrest Drive North (5 year).
 - b. Steven R. and Suzanne M. Anderson, 3009 7th Street North (5 year).
 - c. Trevor and Kathryn Christianson, 1546 5th Street South (5 year).
 - d. New Creations Rentals LLC, 414 Elmwood Avenue South (5 year).
 - e. Marlene and Michael W. Thorstad, 1621 11th Street North (5 year).
 - f. Jeffrey S. and Ivy A. Samson, 1447 3rd Avenue South (5 year).
 - g. Kevin and Nan Schiermeister, 1630 6th Street South (5 year).
 - h. Mary A. Bernier, 513 24th Avenue North (5 year).
 - i. Stephen P. and Shawn R. Lind, 3137 24th Avenue South (3 Year).
- 6. City Commission 2018 meeting schedule.

7. Grant Agreement with Dakota Medical Foundation for the Smarter Lunchrooms Movement and Consulting Services.
8. Purchase of Service Agreement with ND Department of Human Services, Behavioral Health Division for substance abuse prevention community outreach (2017).
9. Purchase of Service Agreement with ND Department of Human Services, Behavioral Health Division for substance abuse prevention community outreach (2018).
10. Services Agreement Recycling Removal Service for City-Owned Receptacles with the Downtown Community Partnership.
11. Services Agreement Trash Removal Service for City-Owned Receptacles with the Downtown Community Partnership.
12. Services Agreement Snow and Ice Management of Railroad Pedestrian Crossings with the Downtown Community Partnership.
13. Change Orders for the City Hall Project:
 - a. No. 13 for an increase of \$240.00 for the general contract.
 - b. No. 6 for an increase of \$4,930.00 for the mechanical contract.
 - c. No. 9 for an increase of \$2,174.00 for the electrical contract.
14. Change Orders for the Police Department Remodeling Project at the Border States Electric Building:
 - a. No. E-3 for an increase of \$1,406.45 for the electrical construction contract.
 - b. No. M-1 for an increase of \$4,080.00 for the mechanical construction contract.
 - c. No. G-1 for an increase of \$2,760.00 for the general construction contract.
 - d. No. G-2 for an increase of \$9,557.00 for the general construction contract.
15. Bid award for the 2017/2018 sidewalk snow and ice removal code enforcement contract (RFP17285).
16. Bid award for the 2017/2018 sidewalk snow and ice removal for city owned properties (RFP17285).
17. Bid award for Project No. FP-17-A1.
18. Final Balancing Change Order No. 2 for an increase of \$4,108.73 for Project No. FM-17-A1.
19. Encroachment Agreement with Salem Evangelical Free Church at 1002 10th Street South, waiving the annual fee.
20. Maintenance Certification/Urban Federal Aid Project with the NDDOT.
21. Concur with the low quote from Key Contracting Inc. in the amount of \$58,000.00 and final payment to the Clay County Highway Department in the amount of \$29,486.92 (Project No. QN-17-B1).
22. Change in local funding from Special Assessments to Sales Tax Funds for Improvement District No. QN-17-A1.
23. Bid advertisement for Project No. QN-17-A.

24. Appointments to the Roberts Commons Condominium Board of Managers and Joint Resolution of Owners and Board of Managers of Roberts Commons Condominium Association.
25. Purchase and Occupancy Agreements with Benjamin and Emily Pitz for 7305 University Drive South.
26. Contract and bond for Project No. TR-17-A1
27. Bills.
28. Memorandum of Offer for permanent easement with Fred M. Hector, Jr. Improvement District No. UN-15-B1.
29. Contract Work Authorization Request from the NDDOT for an increase of \$103,630.08 for Improvement District No. PR-17-B0.
30. Time Extension No. 1 to 11/10/17 for Improvement District No. BN-17-G1.
31. Time Extension No. 2 to 11/12/17 for Improvement District No. BR-17-J1.
32. Reimbursement Agreement for Utility Infrastructure with Consolidated Communications Enterprise Services, Inc. in an estimated amount of \$26,310.00 (Improvement District No. PR-17-A1).
33. Addition of Improvement District No. BR-18-B1 to the 2018 Capital Improvement Plan
34. Amendment to Agreement for Reconstruction of Underpass with the NDDOT and BNSF Railway Company for the 10th Street Reconstruction Project (Improvement District No. BR-18-B1).
35. Create Improvement District Nos. BR-18-B and PR-17-B.

REGULAR AGENDA:

36. All in One Recycling Update
37. State Water Commission requests for Cost Reimbursement for FM Diversion Flood Project Costs:
 - a. Costs totaling \$1,565,228.00.
 - b. Costs totaling \$708,163.00.
38. Public Hearings - 5:15 pm:
 - a. Special Assessment list for Park District 2006-2 Phase V Improvement District No. 7150.
 - b. Special Assessment list for Water Main Replacement, Force Main Construction, Street Reconstruction Improvement District No. BR-16-B; continued from 10/9/17 Regular Meeting.
 - c. Application filed by Daran's Southern Soul Food d/b/a Daran's Southern Soul Food for a Class "GH" Alcoholic Beverage License at 30 University Drive North.

- d. Application filed by Reese & Riley's LLC d/b/a Reese Riley Bistro for a Class "GH" Alcoholic Beverage License at 2653 45th Street South.
 - e. Tunheim Addition (2778 40th Avenue North); approval recommended by the Planning Commission on 9/5/17:
 - 1. Zoning change from AG, Agricultural to LI, Limited Industrial.
 - 2. 1st reading of rezoning Ordinance.
 - 3. Plat of Tunheim Addition.
 - f. Sidewalk Waiver request on Lots 1-5, Block 7, Rocking Horse Farm 2nd Addition (4824, 4838, 4852, 4876 and 4894 Rocking Horse Circle South); approval recommended by the Planning Commission on 10/3/17.
 - g. Proposed change in the Youth Passenger Fare for MATBUS Fixed Route Service.
39. Recommendation to reappoint Heather Fischer and Paul Gleye to the Historic Preservation Commission.
40. Consider funding plan for the demolition of the Old City Hall.
41. Consider Resolution to authorize the filing of an application with the ND Department of Health for a loan under the Clean Water Act for the Membrane Water Treatment Plant and Improvements Project.
42. Election Reform Proposals.

People with disabilities who plan to attend the meeting and need special accommodations should contact the Commission Office at 701.241.1310. Please contact us at least 48 hours before the meeting to give our staff adequate time to make arrangements.

Minutes are available on the City of Fargo website at www.FargoND.gov/citycommission.



Office of the City Attorney

City Attorney
Erik R. Johnson

Assistant City Attorney
Nancy J. Morris

October 19, 2017

Board of City Commissioners
City Hall
200 North 3rd Street
Fargo, ND 58102

RE: Amending ordinance to correct scrivener's error-Section 20-0401

Dear Commissioners:

Enclosed for your approval is an ordinance that is designed merely to correct a scrivener's error. In 2015 the City Commission approved ordinance number 4997 which removed certain conditions for "Household Living" in the Downtown Mixed-Use, "DMU", zoning district. Thus, the use table (LDC Table 20-0401) was modified to allow attached houses, duplexes and multi-dwelling structures to be permitted by right in the DMU. Inadvertently, this amendment was not carried-through in more recent LDC text amendments approved in January and October of this year (Ordinance Nos. 5078 and 5116). The enclosed amending ordinance is intended to correct this omission. As a result, letter "P" will be denoted under the DMU zoning district for Household Living in the specific use types of "House, Attached", "Duplex" and "Multi-Dwelling Structure".

SUGGESTED MOTION: I move to waive the receipt and filing one week prior to first reading and that this be the first reading, by title, of an Ordinance Amending Section 20-0401 of Article 20-04 of Chapter 20 of the Fargo Municipal Code (Land Development Code) Relating to Use Regulations.

Sincerely,

A handwritten signature in black ink, appearing to be "ERJ", written over a horizontal line.

Erik R. Johnson

ERJ/lmw

Enclosure



OFFICE OF THE CITY ATTORNEY
FARGO, NORTH DAKOTA

ORDINANCE NO. _____
AN ORDINANCE AMENDING SECTION
20-0401 OF ARTICLE 20-04 OF CHAPTER 20 OF THE FARGO
MUNICIPAL CODE RELATING TO USE REGULATIONS

1 WHEREAS, the electorate of the city of Fargo has adopted a home rule charter in accordance
with Chapter 40-05.1 of the North Dakota Code; and,

2 WHEREAS, Section 40-05.1-06 of the North Dakota Century Code provides that the City
3 shall have the right to implement home rule powers by ordinance; and,

4 WHEREAS, Section 40-05.1-05 of the North Dakota Century Code provides that said home
5 rule charter and any ordinances made pursuant thereto shall supersede state laws in conflict therewith
and shall be liberally construed for such purposes; and,

6 WHEREAS, the Board of City Commissioners deems it necessary and appropriate to
7 implement such authority by the adoption of this ordinance;

8 NOW, THEREFORE,

9 Be It Ordained by the Board of City Commissioners of the City of Fargo:

10
11 Section 1. Amendment.

12 Section 20-0401 of Article 20-04 of Chapter 20 of the Fargo Municipal Code is
13 hereby amended to change the Use for DMU category under Household Living from “use
14 permitted by-right but subject to use-specific standards of Sec. 20-0402” to “use permitted
15 by-right” in the DMU zoning district under the specified use types of “House, Attached”,
“Duplex” and “Multi-Dwelling Structure”, and, thus, said Section 20-0401 is amended to
read as follows:

16 **[Remainder of page intentionally left blank]**
17
18
19
20
21
22
23

OFFICE OF THE CITY ATTORNEY
FARGO, NORTH DAKOTA

ORDINANCE NO. _____

Article 20-04
Use Regulations

§20-0401 Use Table

Table 20-0401 lists the uses allowed within zoning districts.

A. Use Categories

All of the use categories listed in Table 20-0401 are explained in Sec. 20-1203. The second column of the use table contains an abbreviated explanation of the respective use category. If there is a conflict between the abbreviated definition and the full explanation contained in Sec. 20-1203, the provisions of Sec. 20-1203 will control.

B. P Uses Permitted By-Right

A “P” indicates that a use category is allowed by-right in the respective zoning district. These permitted uses are subject to all other applicable regulations of this Land Development Code.

C. C Conditional Uses

A “C” indicates that a use category is allowed only if reviewed and approved as a Conditional Use, in accordance with the Conditional Use review procedures of Sec. 20-0909. Conditional Uses are subject to all other applicable regulations of this Land Development Code.

D. /C Uses Subject to Specific Conditions

A “P” or a “C” that is accompanied by the symbol “/C” indicates that the listed use type is subject to use-specific conditions. The standards are listed alphabetically in Sec. 20-0402.

E. - Uses Not Allowed

A “-” indicates that a use type is not allowed in the respective zoning district, unless it is otherwise expressly allowed by other regulations of this Land Development Code.

F. New or Unlisted Uses

If an application is submitted for a use type that is not listed in the use table, the Zoning Administrator shall be authorized to make a similar use interpretation based on the use category descriptions of Sec. 20-1203 and the similar use interpretation criteria of Sec. 20-1203-B. If the Zoning Administrator determines that the proposed use does not fit any of the use category descriptions of Sec. 20-1203, no similar use interpretation shall be made. In the event that a similar use interpretation cannot be made, the Zoning Administrator shall be authorized to allow the proposed use type as a conditional use in the LI district or as a use permitted by-right in the GI district.

OFFICE OF THE CITY ATTORNEY
FARGO, NORTH DAKOTA

ORDINANCE NO. _____

* * * *

Section 3. Penalty.

A person who willfully violates this ordinance is guilty of an infraction. Every person, firm or corporation violating an ordinance which is punishable as an infraction shall be punished by a fine not to exceed \$1,000; the court to have power to suspend said sentence and to revoke the suspension thereof.

Section 4. Effective Date.

This ordinance shall be in full force and effect from and after its passage, approval and publication.

Timothy J. Mahoney, Mayor

Attest:

Steven Sprague, City Auditor

First Reading:
Second Reading:
Final Passage:
Publication:

(SEAL)

1
2
3
4
5
6
7
8
9
10
11
12
13
14
15
16
17
18
19
20
21
22
23

②

TO: BOARD OF CITY COMMISSIONERS

FROM: KENT COSTIN, DIRECTOR OF FINANCE *KAC*

RE: FINANCIAL STATUS REPORT FOR MAJOR OPERATING FUNDS FOR PERIOD ENDING SEPTEMBER 30, 2017

DATE: OCTOBER 9, 2017

The Finance Department is presenting the third quarter financial status report covering our major operating funds. This report covers year to date activity through September 30, 2017.

This has been prepared in accordance with the Finance Committee's policy of formal quarterly financial updates as a supplement to the monthly financial report provided each month for the General Fund. Variance explanations, if any, are provided where applicable.

Suggested Motion:

Approve the financial status report for the third quarter of FY 2017 for all major operating funds.

**CITY OF FARGO, NORTH DAKOTA
FINANCIAL STATUS REPORT
BUDGET TO ACTUAL Y-T-D THROUGH SEPTEMBER 30, 2017**

REVENUES:	Budget	Actual	Variance	Variance Percentage	Notes
General Fund	\$ 66,945,000	\$ 66,220,000	\$ (725,000)	-1.1%	
Enterprise Funds:					
Water	17,334,000	17,361,000	27,000	0.2%	
Solid Waste	11,537,000	11,237,000	(300,000)	-2.6%	
Wastewater	8,494,000	8,320,000	(174,000)	-2.0%	
Street Lighting	1,405,000	1,439,000	34,000	2.4%	
Forestry	1,344,000	1,370,000	26,000	1.9%	
Storm Sewer	1,178,000	1,182,000	4,000	0.3%	
Vector Control	500,000	510,000	10,000	2.0%	
Total Enterprise Funds	41,792,000	41,419,000	(373,000)	-0.9%	
Total Operating Funds	\$ 108,737,000	\$ 107,639,000	\$ (1,098,000)	-1.0%	

Reporting Basis: Revised Budget

EXPENDITURES:	Budget	Actual	Variance	Variance Percentage	%
General Fund	\$ 73,815,000	\$ 68,836,000	\$ 4,979,000	6.7%	
Enterprise Funds:					
Water	15,513,000	13,530,000	1,983,000	12.8%	
Solid Waste	12,563,000	13,142,000	(579,000)	-4.6%	
Wastewater	7,880,000	7,044,000	836,000	10.6%	
Storm Sewer	1,353,000	1,238,000	115,000	8.5%	
Forestry	1,497,000	1,420,000	77,000	5.1%	
Street Lighting	1,464,000	1,239,000	225,000	15.4%	
Vector Control	613,000	569,000	44,000	7.2%	
Total Enterprise Funds	40,883,000	38,182,000	2,701,000	6.6%	
Total Operating Funds	\$ 114,698,000	\$ 107,018,000	\$ 7,680,000	6.7%	

Reporting Basis: Revised Budget

Footnotes:

3

**CITY OF FARGO
GENERAL FUND - BUDGET TO ACTUAL
THROUGH SEPTEMBER 30, 2017
(UNAUDITED)**

	2017 BUDGET	2017 ACTUAL	VARIANCE
REVENUES:			
Taxes	\$ 25,464,886	\$ 26,421,901	\$ 957,015
Licenses & Permits	3,401,446	3,078,671	(322,775)
Fines & Traffic Tickets	1,684,030	1,457,939	(226,091)
Intergovernmental Revenue	11,163,756	10,656,868	(506,888)
Charges for Services	12,572,084	11,005,986	(1,566,098)
Interest	2,046,735	2,665,784	619,049
Miscellaneous Revenue	545,537	559,053	13,516
Transfers In	10,066,479	10,373,362	306,883
Total Revenues	\$ 66,944,953	\$ 66,219,564	\$ (725,389)
EXPENDITURES:			
City Administrator	\$ 4,543,777	\$ 4,371,463	\$ 172,314
Finance	5,589,932	5,472,034	117,898
Planning & Development	3,526,688	2,948,842	577,846
Transit	5,517,690	5,040,762	476,928
Public Works	11,902,292	11,287,426	614,866
Fire Department	9,684,434	9,462,049	222,385
Police	14,524,793	14,280,070	244,723
Health	8,080,561	8,198,595	(118,034)
Library	3,094,952	3,095,561	(609)
Commission	474,150	433,828	40,322
Civic Center	325,674	292,674	33,000
Social Services	358,400	323,403	34,997
Capital Outlay	1,820,423	655,053	1,165,370
Vehicle Replacement/IT	1,753,120	823,896	929,224
Contingency	296,353	15,006	281,347
Transfers Out	2,321,580	2,135,785	185,795
Total Expenditures	\$ 73,814,819	\$ 68,836,447	\$ 4,978,372
Excess of Revenue Over (Under) Expenditures	\$ (6,869,866)	\$ (2,616,883)	\$ 4,252,983



APPLICATION FOR A LOCAL PERMIT OR CHARITY LOCAL PERMIT
 OFFICE OF ATTORNEY GENERAL
 SFN 9338 (08/2016)

46

\$2500
 10-18-17
 CC 7302

Application for: Local Permit * Charity Local Permit (one event per year)

Name of Non-profit Organization		Date(s) of Activity		For a raffle, provide drawing date(s):	
UNITED WAY OF CASS-CLAY		10-27 to 10-27			
Person Responsible for the Gaming Operation and Disbursement of Net Income		Title	Business Phone Number		
TRAVIS CHRISTOPHER		RESOURCE DEV	701 237 5050		
Business Address		City	State	Zip Code	
219 7TH STS		FARGO	ND	58103	
Mailing Address (if different)		City	State	Zip Code	
PO BOX 1609		FARGO	ND	58107	
Name of Site Where Game(s) will be Conducted		Site Address			
NODAK MUTUAL INSURANCE		1101 1ST AVE N			
City		State	Zip Code	County	
FARGO		ND	58103	CASS	
Check the Game(s) to be Conducted. * Poker, Twenty-one, and Paddlewheels may be Conducted only by a Charity Local Permit.					
<input type="checkbox"/> Bingo <input checked="" type="checkbox"/> Raffle <input type="checkbox"/> Raffle Board <input type="checkbox"/> Calendar Raffle <input type="checkbox"/> Sports Pool <input type="checkbox"/> Poker * <input type="checkbox"/> Twenty-one * <input type="checkbox"/> Paddlewheels *					

DESCRIPTION AND RETAIL VALUE OF PRIZES TO BE AWARDED

Game Type	Description of Prize	Retail Value of Prize	Game Type	Description of Prize	Retail Value of Prize
50/50 RAFFLE	1/2 OF \$	500.00			

(Limit \$12,000 per year)
 Total: \$ 500.00

Intended uses of gaming proceeds: INTERNAL COMPANY RAFFLE TO SUPPORT MISSION OF UNITED WAY

Does the organization presently have a state gaming license? No Yes - If "Yes," the organization is not eligible for a local permit or charity local permit and should call the Office of Attorney General at 1-800-326-9240.

Has the organization received a charity local permit from this or another city or county for the fiscal year July 1 through June 30? No Yes - If "Yes," the organization does not qualify for a local permit or charity local permit.

Has the organization received a local permit from this or another city or county for the fiscal year July 1 through June 30? No Yes - If "Yes," indicate the total value of all prizes previously awarded: \$ 4,204.00 This amount is part of the total prize limit of \$12,000 per year.

Signature of Organization's Top Executive Official	Date	Title	Business Phone Number
<i>Travis Christopher</i>	10-18-17	PRESIDENT	701 237 5050



(40)

APPLICATION FOR A LOCAL PERMIT OR CHARITY LOCAL PERMIT

OFFICE OF ATTORNEY GENERAL
SFN 9338 (08/2016)

Application for: Local Permit * Charity Local Permit (one event per year)

Name of Non-profit Organization <i>American Legion Auxiliary</i>		Date(s) of Activity <i>Nov 2017 to June 30, 2018</i>		For a raffle, provide drawing date(s): <i>July 1, 2018</i>	
Person Responsible for the Gaming Operation and Disbursement of Net Income <i>Mavis Goodroad Dept Pres.</i>		Title <i>Dept President</i>		Business Phone Number <i>701-361-0413</i>	
Business Address <i>3030 22nd St S</i>		City <i>Fargo</i>		State <i>ND</i>	Zip Code <i>58103</i>
Mailing Address (if different)		City		State	Zip Code
Name of Site Where Game(s) will be Conducted <i>VA NA Dept.</i>		Site Address <i>1801-23rd St N</i>			
City <i>Fargo</i>		State <i>ND</i>	Zip Code <i>58102</i>	County <i>Cass</i>	
Check the Game(s) to be Conducted: * Poker, Twenty-one, and Paddlewheels may be Conducted only by a Charity Local Permit.					
<input type="checkbox"/> Bingo <input checked="" type="checkbox"/> Raffle <input type="checkbox"/> Raffle Board <input type="checkbox"/> Calendar Raffle <input type="checkbox"/> Sports Pool <input type="checkbox"/> Poker * <input type="checkbox"/> Twenty-one * <input type="checkbox"/> Paddlewheels *					

DESCRIPTION AND RETAIL VALUE OF PRIZES TO BE AWARDED

Game Type	Description of Prize	Retail Value of Prize	Game Type	Description of Prize	Retail Value of Prize
<i>Raffle</i>	<i>Quilt</i>	<i>800</i>			
<i>Raffle</i>	<i>TV</i>	<i>350</i>			
<i>Raffle</i>	<i>Flower wreath</i>	<i>350</i>			
Total: (Limit \$12,000 per year)					<i>\$ 1500</i>

Intended uses of gaming proceeds: *Donation for Veterans VA Medical Center, Lisbon Home, Madys Ray Shelter*

Does the organization presently have a state gaming license? No Yes - If "Yes," the organization is not eligible for a local permit or charity local permit and should call the Office of Attorney General at 1-800-326-9240.

Has the organization received a charity local permit from this or another city or county for the fiscal year July 1 through June 30? No Yes - If "Yes," the organization does not qualify for a local permit or charity local permit.

Has the organization received a local permit from this or another city or county for the fiscal year July 1 through June 30? No Yes - If "Yes," indicate the total value of all prizes previously awarded: \$ _____ . This amount is part of the total prize limit of \$12,000 per year.

Signature of Organization's Top Executive Official <i>Mavis Goodroad</i>	Date <i>10-18-17</i>	Title <i>Dept President</i>	Business Phone Number <i>701-361-0413</i>
---	-------------------------	--------------------------------	--



APPLICATION FOR A LOCAL PERMIT OR CHARITY LOCAL PERMIT
 OFFICE OF ATTORNEY GENERAL
 SFN 9338 (08/2016)

4d

\$25.00
 V#2694
 10-18-17

Application for: Local Permit Charity Local Permit (one event per year)

Name of Non-profit Organization Heart Springs Community Healing Center		Date(s) of Activity Dec 5 to Dec 5th	For a raffle, provide drawing date(s): Dec 5th	
Person Responsible for the Gaming Operation and Disbursement of Net Income Jan Nelson		Title Executive Director	Business Phone Number 701-261-3142	
Business Address 2010 N Elm St		City Fargo	State ND	Zip Code 58102
Mailing Address (if different)		City	State	Zip Code
Name of Site Where Game(s) will be Conducted Heart Springs Community Healing Center		Site Address 2010 N Elm St		
City Fargo		State ND	Zip Code 58102	County Cass

Check the Game(s) to be Conducted: * Poker, Twenty-one, and Paddlewheels may be Conducted only by a Charity Local Permit.

Bingo Raffle Raffle Board Calendar Raffle Sports Pool Poker * Twenty-one * Paddlewheels *

DESCRIPTION AND RETAIL VALUE OF PRIZES TO BE AWARDED

Game Type	Description of Prize	Retail Value of Prize	Game Type	Description of Prize	Retail Value of Prize
Raffle	concert Package	\$900	Raffle	Family Package	\$210
Raffle	cut & color Package	\$200	Raffle	Shopping spree Package	\$250
Raffle	Pride of Dakota Basket	\$220	Raffle	winter Package	\$139
Raffle	Swanson health Package	\$184	Raffle	Bread making Package	\$76
Raffle	For the home Package	\$156	Raffle	A & E Package	\$101
Raffle	Meal kit Package	\$70	Raffle	SM Package	\$96
Raffle	Pet Package	\$140	Raffle	Picnic Package	\$75
Raffle	Womens Package	\$138	Raffle	Coffee Package	\$50
Raffle	Steam Threshers Package	\$136	Raffle	FM out 68 Night out 53	\$121
Total:					(Limit \$12,000 per year) \$ 3,262

Intended uses of gaming proceeds: For use in Therapy Programs

Does the organization presently have a state gaming license? No Yes - If "Yes," the organization is not eligible for a local permit or charity local permit and should call the Office of Attorney General at 1-800-326-9240.

Has the organization received a charity local permit from this or another city or county for the fiscal year July 1 through June 30? No Yes - If "Yes," the organization does not qualify for a local permit or charity local permit.

Has the organization received a local permit from this or another city or county for the fiscal year July 1 through June 30? No Yes - If "Yes," indicate the total value of all prizes previously awarded: \$ _____. This amount is part of the total prize limit of \$12,000 per year.

Signature of Organization's Top Executive Official Jan Nelson	Date 10/17/17	Title ED	Business Phone Number 701-261-3142
---	-------------------------	--------------------	--



APPLICATION FOR A LOCAL PERMIT OR CHARITY LOCAL PERMIT
OFFICE OF ATTORNEY GENERAL
 SFN 9338 (08/2016)

44

\$2500
10-19-17
cash

Application for: Local Permit * Charity Local Permit (one event per year)

Name of Non-profit Organization CENTENNIAL ELEMENTARY PTO		Date(s) of Activity 10/27/17 to 5/31/18		For a raffle, provide drawing date(s):	
Person Responsible for the Gaming Operation and Disbursement of Net Income CHRIS ANDREACCHI		Title CO-PRESIDENT		Business Phone Number 701-799-9716	
Business Address 4201 25 ST S		City FARGO		State ND	Zip Code 58104
Mailing Address (if different)		City		State	Zip Code
Name of Site Where Game(s) will be Conducted CENTENNIAL ELEMENTARY		Site Address 4201 25 ST S			
City FARGO		State ND	Zip Code 58104	County CASS	
Check the Game(s) to be Conducted: * Poker, Twenty-one, and Paddlewheels may be Conducted only by a Charity Local Permit. <input checked="" type="checkbox"/> Bingo <input type="checkbox"/> Raffle <input type="checkbox"/> Raffle Board <input type="checkbox"/> Calendar Raffle <input type="checkbox"/> Sports Pool <input type="checkbox"/> Poker * <input type="checkbox"/> Twenty-one * <input type="checkbox"/> Paddlewheels *					

DESCRIPTION AND RETAIL VALUE OF PRIZES TO BE AWARDED

Game Type	Description of Prize	Retail Value of Prize	Game Type	Description of Prize	Retail Value of Prize
BINGO	FOOD/DRINK	\$ 200			
BINGO	BOOKS	\$ 200			
BINGO	GIFT CARDS	\$ 500			
BINGO	SPORTS GEAR	\$ 200			
BINGO	CLOTHING	\$ 200			
BINGO	ELECTRONICS	\$ 400			
BINGO	BOYS TOYS	\$ 200			
BINGO	GIRLS TOYS	\$ 200			
BINGO	EVENT TICKETS	\$ 500			
					(Limit \$12,000 per year) Total: \$ 2,600

Intended uses of gaming proceeds: FUNDRAISERS FOR ELEMENTARY STUDENTS FOR TEACHER SUPPLIES, CLASSROOM AIDS, FIELD TRIPS, MUSIC, PE AND ART SUPPLIES.

Does the organization presently have a state gaming license? No Yes - If "Yes," the organization is not eligible for a local permit or charity local permit and should call the Office of Attorney General at 1-800-326-9240.

Has the organization received a charity local permit from this or another city or county for the fiscal year July 1 through June 30? No Yes - If "Yes," the organization does not qualify for a local permit or charity local permit.

Has the organization received a local permit from this or another city or county for the fiscal year July 1 through June 30? No Yes - If "Yes," indicate the total value of all prizes previously awarded: \$ _____ . This amount is part of the total prize limit of \$12,000 per year.

Signature of Organization's Top Executive Official <i>Chris Andreacchi</i>	Date 10/18/17	Title CO-PRESIDENT	Business Phone Number 701-799-9716
---	-------------------------	------------------------------	--



APPLICATION FOR A LOCAL PERMIT OR CHARITY LOCAL PERMIT
 OFFICE OF ATTORNEY GENERAL
 SFN 9338 (08/2016)

49

\$25.00
 10-18-17
 CC 3872

Application for: Local Permit Charity Local Permit (one event per year)

Name of Non-profit Organization <u>United Way of Cass-Clay</u>	Date(s) of Activity <u>Nov 2 to Nov 2</u>	For a raffle, provide drawing date(s): <u>Nov 2</u>	
Person Responsible for the Gaming Operation and Disbursement of Net Income <u>Charnel Carlson</u>	Title <u>Community Engagement Manager</u>	Business Phone Number <u>(701) 237-5050</u>	
Business Address <u>719 7th St S PO Box 16009</u>	City <u>Fargo</u>	State <u>ND</u>	Zip Code <u>58107</u>
Mailing Address (if different)	City	State	Zip Code
Name of Site Where Game(s) will be Conducted <u>Delta by Marriott</u>	Site Address <u>1635 42nd St S</u>		
City <u>Fargo</u>	State <u>ND</u>	Zip Code <u>58103</u>	County <u>Cass</u>
Check the Game(s) to be Conducted: * Poker, Twenty-one, and Paddlewheels may be Conducted only by a Charity Local Permit.			
<input type="checkbox"/> Bingo <input type="checkbox"/> Raffle <input checked="" type="checkbox"/> Raffle Board <input type="checkbox"/> Calendar Raffle <input type="checkbox"/> Sports Pool <input type="checkbox"/> Poker * <input type="checkbox"/> Twenty-one * <input type="checkbox"/> Paddlewheels *			

DESCRIPTION AND RETAIL VALUE OF PRIZES TO BE AWARDED

Game Type	Description of Prize	Retail Value of Prize	Game Type	Description of Prize	Retail Value of Prize
Raffle Board	<u>Carlson went 2 Signed Football</u>	<u>\$1,000</u>			
Raffle Board	<u>hand painted motivational sign</u>	<u>\$139.00</u>			
Total:					(Limit \$12,000 per year) <u>\$ 1,139.00</u>

Intended uses of gaming proceeds: _____

Does the organization presently have a state gaming license? No Yes - If "Yes," the organization is not eligible for a local permit or charity local permit and should call the Office of Attorney General at 1-800-826-9240.

Has the organization received a charity local permit from this or another city or county for the fiscal year July 1 through June 30? No Yes - If "Yes," the organization does not qualify for a local permit or charity local permit.

Has the organization received a local permit from this or another city or county for the fiscal year July 1 through June 30? No Yes - If "Yes," indicate the total value of all prizes previously awarded: \$ 47041. This amount is part of the total prize limit of \$12,000 per year.

Signature of Organization's Top Executive Official <u>[Signature]</u>	Date <u>10-19-17</u>	Title <u>President</u>	Business Phone Number <u>701.237.5050</u>
--	-------------------------	---------------------------	--



APPLICATION FOR A LOCAL PERMIT OR CHARITY LOCAL PERMIT
OFFICE OF ATTORNEY GENERAL
SFN 9338 (08/2016)

10-18-17
V8642

Application for: [X] Local Permit * [] Charity Local Permit (one event per year)

Form with fields: Name of Non-profit Organization (Fargo Angels Hockey), Date(s) of Activity (12-3-17), Person Responsible (Steve Mehls), Title (Treasurer), Business Address (P.O. Box 3258), City (Fargo), State (ND), Zip Code (58108), Name of Site (Southwest Ice Arena), Site Address (4404 23rd Ave S), City (Fargo), State (ND), Zip Code (58103), County (CASS). Includes checkboxes for game types: Bingo, Raffle, Raffle Board, Calendar Raffle, Sports Pool, Poker, Twenty-one, Paddlewheels.

DESCRIPTION AND RETAIL VALUE OF PRIZES TO BE AWARDED

Table with 3 columns: Game Type, Description of Prize, Retail Value of Prize. Contains entries: Raffle Board - Beats Headphones - 379.99, Raffle Board - XBOX ONE S - 279.00, Raffle Board - Jersey - 149.00.

Table with 3 columns: Game Type, Description of Prize, Retail Value of Prize. Includes a Total row at the bottom right with value \$807.99 and a note (Limit \$12,000 per year).

Text area for intended uses of gaming proceeds: to help offset the cost of running a not-for-profit youth hockey club which includes running a tournament in Fargo that benefits youth from the F.M. area. Includes questions about state gaming license and charity local permit status.

Signature of Organization's Top Executive Official (AKM), Date (10-19-17), Title (Treasurer), Business Phone Number (701 526 3307).



5a

October 11, 2017

Board of City Commissioners
City Hall
Fargo, ND 58102

Dear Commissioners:

Chapter 57-02.2 of the North Dakota Century Code provides for a property tax exemption for certain types of improvements made to existing buildings.

I have attached a copy of an application for real estate tax exemption of building improvements for the property at 172 North Woodcrest Dr N as submitted by Kevin & Deann M Pladson. A description of the property involved, types of improvements to be made, and assessment information are indicated on the application.

It is my opinion that the value of some of the improvements, referred to in the application, qualifies for the exemption. This exemption would be for the years 2018, 2019, 2020, 2021, & 2022.

The estimated annual tax revenue lost by granting the exemption, based upon the estimated cost of the improvements, would be about \$90 with the City of Fargo's share being \$15.

Sincerely,

A handwritten signature in black ink, appearing to read "Ben Hushka". The signature is fluid and cursive.

Ben Hushka
City Assessor

hah
attachment

Application For Property Tax Exemption For Improvements To Commercial And Residential Buildings North Dakota Century Code ch. 57-02.2 (File with the local city or township assessor)

Property Identification

1. Name of Property Owner Kevin + Deann Pladson Phone No. 701-866-2903
2. Address of Property 172 North Woodcrest Dr N
City FARGO State ND Zip Code 58102
3. Legal description of the property for which the exemption is being claimed. L+23 B1K16 Woodcrest 3rd
4. Parcel Number 01-4060-007000 Residential [X] Commercial [] Central Business District []
5. Mailing Address of Property Owner Same
City State Zip Code

Description Of Improvements For Exemption

6. Describe the type of renovating, remodeling or alteration made to the building for which the exemption is being claimed (attach additional sheets if necessary). Reside Dwelling
7. Building Permit No. 170196 8. Year Built 1972
9. Date of Commencement of making the improvement March 2017
10. Estimated market value of property before improvement \$ 310,300
11. Cost of making the improvement (all labor, material and overhead) \$ 10,800
12. Estimated market value of property after improvement \$ 317,300

Applicant's Certification and Signature

13. I certify that the above information is correct to the best of my knowledge and I apply for this exemption.
Applicant's Signature [Signature] Date 10-9-17

Assessor's Determination

14. The local assessor finds that the improvements in this application has [] has not [] met the qualifications for exemption for the following reason(s): 5 YEARS FOR QUALIFYING WORK
Assessor's Signature [Signature] Date 10/12/17

Action of Governing Body

15. Action taken on this application by local governing board of the county or city: Denied [] Approved []
Approval subject to the following conditions:
Chairman of Governing Body Date

CITY OF
Fargo
ASSESSMENT DEPARTMENT

56

October 11, 2017

Board of City Commissioners
City Hall
Fargo, ND 58102

Dear Commissioners:

Chapter 57-02.2 of the North Dakota Century Code provides for a property tax exemption for certain types of improvements made to existing buildings.

I have attached a copy of an application for real estate tax exemption of building improvements for the property at 3009 7 St N as submitted by Steven R & Suzanne M Anderson. A description of the property involved, types of improvements to be made, and assessment information are indicated on the application.

It is my opinion that the value of some of the improvements, referred to in the application, qualifies for the exemption. This exemption would be for the years 2018, 2019, 2020, 2021, & 2022.

The estimated annual tax revenue lost by granting the exemption, based upon the estimated cost of the improvements, would be about \$95 with the City of Fargo's share being \$15.

Sincerely,

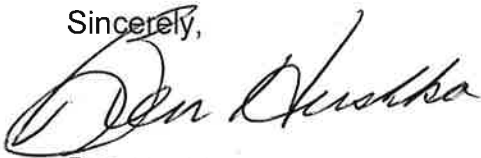

Ben Hushka
City Assessor

hah
attachment

**Application For Property Tax Exemption For Improvements
To Commercial And Residential Buildings**
North Dakota Century Code ch. 57-02.2
(File with the local city or township assessor)

Property Identification

1. Name of Property Owner	<u>Steven + Suzanne Anderson</u>	Phone No.	_____
2. Address of Property	<u>3009 7 st N</u>		
City	<u>FARGO</u>	State	<u>ND</u> Zip Code <u>58102</u>
3. Legal description of the property for which the exemption is being claimed.	<u>L+11 Bkl Knollbrook</u>		
4. Parcel Number	<u>01-1660-00080W</u>	Residential <input checked="" type="checkbox"/>	Commercial <input type="checkbox"/> Central Business District <input type="checkbox"/>
5. Mailing Address of Property Owner	<u>Same</u>		
City	_____	State	_____ Zip Code _____

Description Of Improvements For Exemption

6. Describe the type of renovating, remodeling or alteration made to the building for which the exemption is being claimed (attach additional sheets if necessary).	<u>Reside Dwelling</u>		
7. Building Permit No.	<u>171113</u>	8. Year Built	<u>1961</u>
9. Date of Commencement of making the improvement	<u>June 2017</u>		
10. Estimated market value of property before improvement	\$	<u>158,100</u>	_____
11. Cost of making the improvement (all labor, material and overhead)	\$	<u>14,977</u>	_____
12. Estimated market value of property after improvement	\$	<u>165,600</u>	_____

Applicant's Certification and Signature

13. I certify that the above information is correct to the best of my knowledge and I apply for this exemption.	_____		
Applicant's Signature	<u>Steven R. Anderson</u>	Date	<u>10/18/17</u>

Assessor's Determination

14. The local assessor finds that the improvements in this application <input checked="" type="checkbox"/> has <input type="checkbox"/> has not <input type="checkbox"/> met the qualifications for exemption for the following reason(s):	<u>5 YEARS FOR QUALIFYING WORK</u>		
Assessor's Signature	<u>Don Denabka</u>	Date	<u>10/21/17</u>

Action of Governing Body

15. Action taken on this application by local governing board of the county or city: Denied <input type="checkbox"/> Approved <input type="checkbox"/>	_____		
Approval subject to the following conditions:	_____		
Chairman of Governing Body	_____	Date	_____

CITY OF
Fargo
ASSESSMENT DEPARTMENT

50

October 12, 2017

Board of City Commissioners
City Hall
Fargo, ND 58102

Dear Commissioners:

Chapter 57-02.2 of the North Dakota Century Code provides for a property tax exemption for certain types of improvements made to existing buildings.

I have attached a copy of an application for real estate tax exemption of building improvements for the property at 1546 5 St S as submitted by Trevor & Kathryn Christianson. A description of the property involved, types of improvements to be made, and assessment information are indicated on the application.

It is my opinion that the value of some of the improvements, referred to in the application, qualifies for the exemption. This exemption would be for the years 2018, 2019, 2020, 2021, & 2022.

The estimated annual tax revenue lost by granting the exemption, based upon the estimated cost of the improvements, would be about \$120 with the City of Fargo's share being \$20.

Sincerely,

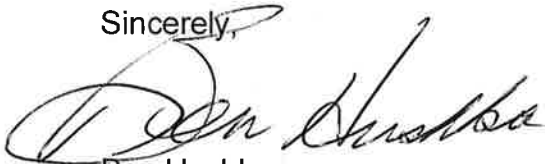

Ben Hushka
City Assessor

hah
attachment

**Application For Property Tax Exemption For Improvements
To Commercial And Residential Buildings**

North Dakota Century Code ch. 57-02.2
(File with the local city or township assessor)

Property Identification

1. Name of Property Owner Trevor and Katy Christianson Phone No. 701-200-2017

2. Address of Property 1546 5th St. S

City FARGO State ND Zip Code 58103

3. Legal description of the property for which the exemption is being claimed, h 268,
Belmont Park Add.

4. Parcel Number 01-0120-02450-000 Residential Commercial Central Business District

5. Mailing Address of Property Owner 1546 5th St. S

City Fargo State ND Zip Code 58103

Description Of Improvements For Exemption

6. Describe the type of renovating, remodeling or alteration made to the building for which the exemption is being claimed (attach additional sheets if necessary). Kitchen remodel and window and window trim replacement.

7. Building Permit No. 161999-170120 8. Year Built 1929

9. Date of Commencement of making the improvement February 13, 2017

10. Estimated market value of property before improvement \$ 115,500

11. Cost of making the improvement (all labor, material and overhead) \$ 45,000 (including appliances)

12. Estimated market value of property after improvement \$ 125,000

Applicant's Certification and Signature

13. I certify that the above information is correct to the best of my knowledge and I apply for this exemption.

Applicant's Signature K. Christianson Date 6/5/2017

Assessor's Determination

14. The local assessor finds that the improvements in this application has has not met the qualifications for exemption for the following reason(s): 5 YEARS FOR QUALIFYING WORK

Assessor's Signature Don Dushka Date 10/12/17

Action of Governing Body

15. Action taken on this application by local governing board of the county or city: Denied Approved

Approval subject to the following conditions: _____

Chairman of Governing Body _____ Date _____

CITY OF
Fargo
ASSESSMENT DEPARTMENT

5d

October 10, 2017

Board of City Commissioners
City Hall
Fargo, ND 58102

Dear Commissioners:

Chapter 57-02.2 of the North Dakota Century Code provides for a property tax exemption for certain types of improvements made to existing buildings.

I have attached a copy of an application for real estate tax exemption of building improvements for the property at 414 Elmwood Ave S as submitted by New Creations Rentals LLC. A description of the property involved, types of improvements to be made, and assessment information are indicated on the application.

It is my opinion that the value of some of the improvements, referred to in the application, qualifies for the exemption. This exemption would be for the years 2018, 2019, 2020, 2021, & 2022.

The estimated annual tax revenue lost by granting the exemption, based upon the estimated cost of the improvements, would be about \$100 with the City of Fargo's share being \$15.

Sincerely,

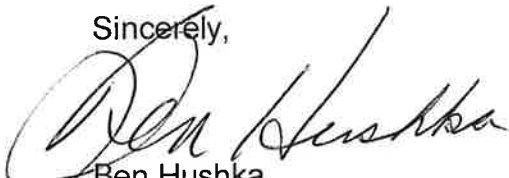
Ben Hushka
City Assessor

hah
attachment

Application For Property Tax Exemption For Improvements To Commercial And Residential Buildings North Dakota Century Code ch. 57-02.2 (File with the local city or township assessor)

Property Identification

1. Name of Property Owner New Creations Rentals LLC Phone No. 701-361-9303
2. Address of Property 414 Elmwood Ave
City FARGO State ND Zip Code 58103
3. Legal description of the property for which the exemption is being claimed. Lt 252 & Pt 253 Belmont Park
4. Parcel Number 01-0120-0229020 Residential [X] Commercial [] Central Business District []
5. Mailing Address of Property Owner 2150 38 St S
City Moorhead State MN Zip Code 56560

Description Of Improvements For Exemption

6. Describe the type of renovating, remodeling or alteration made to the building for which the exemption is being claimed (attach additional sheets if necessary). Reside Dwelling & new deck
7. Building Permit No. 170745 8. Year Built 1919
9. Date of Commencement of making the improvement May 2017
10. Estimated market value of property before improvement \$ 122,000
11. Cost of making the improvement (all labor, material and overhead) \$ 5,000
12. Estimated market value of property after improvement \$ 129,900

Applicant's Certification and Signature

13. I certify that the above information is correct to the best of my knowledge and I apply for this exemption.
Applicant's Signature [Signature] Date 10/3/2017

Assessor's Determination

14. The local assessor finds that the improvements in this application has [X] has not [] met the qualifications for exemption for the following reason(s): 5 YEARS FOR QUALIFYING WORK
Assessor's Signature [Signature] Date 10/10/17

Action of Governing Body

15. Action taken on this application by local governing board of the county or city: Denied [] Approved []
Approval subject to the following conditions:
Chairman of Governing Body _____ Date _____

CITY OF
Fargo
ASSESSMENT DEPARTMENT

52

October 10, 2017

Board of City Commissioners
City Hall
Fargo, ND 58102

Dear Commissioners:

Chapter 57-02.2 of the North Dakota Century Code provides for a property tax exemption for certain types of improvements made to existing buildings.

I have attached a copy of an application for real estate tax exemption of building improvements for the property at 1621 11 St N as submitted by Marlene M & Michael W Thorstad. A description of the property involved, types of improvements to be made, and assessment information are indicated on the application.

It is my opinion that the value of some of the improvements, referred to in the application, qualifies for the exemption. This exemption would be for the years 2018, 2019, 2020, 2021, & 2022.

The estimated annual tax revenue lost by granting the exemption, based upon the estimated cost of the improvements, would be about \$120 with the City of Fargo's share being \$20.

Sincerely,

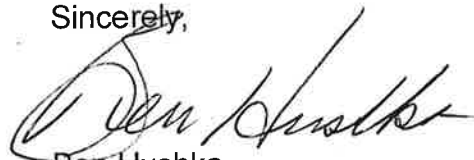

Ben Hushka
City Assessor

hah
attachment

**Application For Property Tax Exemption For Improvements
To Commercial And Residential Buildings**

North Dakota Century Code ch. 57-02.2
(File with the local city or township assessor)

Property Identification

1. Name of Property Owner Marlene + Michael Thorstad Phone No. 701-412-4848

2. Address of Property 1621 11 St N
 City FARGO State ND Zip Code 58102

3. Legal description of the property for which the exemption is being claimed. Lt 19 BIKIO Chandlers Broadway

4. Parcel Number 01-0380-0229000 Residential Commercial Central Business District

5. Mailing Address of Property Owner Same
 City _____ State _____ Zip Code _____

Description Of Improvements For Exemption

6. Describe the type of renovating, remodeling or alteration made to the building for which the exemption is being claimed (attach additional sheets if necessary). Reside Dwelling

7. Building Permit No. 171426 8. Year Built 1948

9. Date of Commencement of making the improvement August 2017

10. Estimated market value of property before improvement \$ 179,100

11. Cost of making the improvement (all labor, material and overhead) \$ 11,500

12. Estimated market value of property after improvement \$ 188,400

Applicant's Certification and Signature

13. I certify that the above information is correct to the best of my knowledge and I apply for this exemption.
 Applicant's Signature Michael Thorstad Date 10-7-17

Assessor's Determination

14. The local assessor finds that the improvements in this application has has not met the qualifications for exemption for the following reason(s): 5 YEARS FOR QUALIFYING WORK
 Assessor's Signature Ken Pundke Date 10/10/17

Action of Governing Body

15. Action taken on this application by local governing board of the county or city: Denied Approved
 Approval subject to the following conditions: _____

 Chairman of Governing Body _____ Date _____

CITY OF
Fargo
ASSESSMENT DEPARTMENT

57

October 10, 2017

Board of City Commissioners
City Hall
Fargo, ND 58102

Dear Commissioners:

Chapter 57-02.2 of the North Dakota Century Code provides for a property tax exemption for certain types of improvements made to existing buildings.

I have attached a copy of an application for real estate tax exemption of building improvements for the property at 1447 3 Ave S as submitted by Jeffrey S & Ivy A Samson. A description of the property involved, types of improvements to be made, and assessment information are indicated on the application.

It is my opinion that the value of some of the improvements, referred to in the application, qualifies for the exemption. This exemption would be for the years 2018, 2019, 2020, 2021, & 2022.

The estimated annual tax revenue lost by granting the exemption, based upon the estimated cost of the improvements, would be about \$715 with the City of Fargo's share being \$120.

Sincerely,

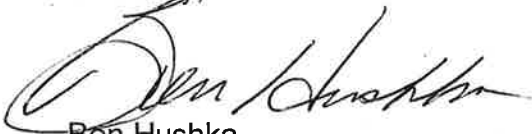

Ben Hushka
City Assessor

hah
attachment

Application For Property Tax Exemption For Improvements To Commercial And Residential Buildings North Dakota Century Code ch. 57-02.2 (File with the local city or township assessor)

Property Identification

1. Name of Property Owner IVY & JEFFREY SAMSON Phone No. 701-793-7903
2. Address of Property 1447 3RD AVE S
City FARGO State ND Zip Code
3. Legal description of the property for which the exemption is being claimed THE SOUTH 100 FEET OF LOT "B", AUDITORS SUBDIVISION OF LOT 2, IN BLOCK 7 OF FULLERS ADDITION TO THE CITY OF FARGO, CASS COUNTY, NORTH DAKOTA
4. Parcel Number 01-0980-01110-Residential [X] Commercial [] Central Business District []
5. Mailing Address of Property Owner 1447 3RD AVES.
City FARGO State ND Zip Code 58103

Description Of Improvements For Exemption

6. Describe the type of renovating, remodeling or alteration made to the building for which the exemption is being claimed (attach additional sheets if necessary). JACK UP PORCH & POUR CONCRETE FOOTINGS. NEW WINDOWS & DOORS, REPAIR STUCCO, PAINT
7. Building Permit No. 171399 8. Year Built 1981
9. Date of Commencement of making the improvement 6/29/17
10. Estimated market value of property before improvement \$ 148,600
11. Cost of making the improvement (all labor, material and overhead) \$ 55,245
12. Estimated market value of property after improvement \$ 203,845

Applicant's Certification and Signature

13. I certify that the above information is correct to the best of my knowledge and I apply for this exemption.
Applicant's Signature [Signature] Date 10/5/17

Assessor's Determination

14. The local assessor finds that the improvements in this application has [X] has not [] met the qualifications for exemption for the following reason(s): 5 YEARS FOR QUALIFYING HOME
Assessor's Signature [Signature] Date 10/10/17

Action of Governing Body

15. Action taken on this application by local governing board of the county or city: Denied [] Approved []
Approval subject to the following conditions:
Chairman of Governing Body Date

CITY OF
Fargo
ASSESSMENT DEPARTMENT

59

October 16, 2017

Board of City Commissioners
City Hall
Fargo, ND 58102

Dear Commissioners:

Chapter 57-02.2 of the North Dakota Century Code provides for a property tax exemption for certain types of improvements made to existing buildings.

I have attached a copy of an application for real estate tax exemption of building improvements for the property at 1630 6 St S as submitted by Kevin & Nan Schiermeister. A description of the property involved, types of improvements to be made, and assessment information are indicated on the application.

It is my opinion that the value of some of the improvements, referred to in the application, qualifies for the exemption. This exemption would be for the years 2018, 2019, 2020, 2021 & 2022.

The estimated annual tax revenue lost by granting the exemption, based upon the estimated cost of the improvements, would be about \$1260 with the City of Fargo's share being \$215.

Sincerely,



Ben Hushka
City Assessor

hah
attachment

**Application For Property Tax Exemption For Improvements
To Commercial And Residential Buildings**

North Dakota Century Code ch. 57-02.2
(File with the local city or township assessor)

Property Identification

1. Name of Property Owner Kevin + Nan Schiermeister Phone No. ^{701/} 361-5426

2. Address of Property 1630 6th St. S.

City FARGO State ND Zip Code 58103

3. Legal description of the property for which the exemption is being claimed. Lot 9 Block 7 Lewis Addition

4. Parcel Number 01-1720-00720-000 Residential Commercial Central Business District

5. Mailing Address of Property Owner 4106 45th St. N

City Fargo State ND Zip Code 58102

Description Of Improvements For Exemption

6. Describe the type of renovating, remodeling or alteration made to the building for which the exemption is being claimed (attach additional sheets if necessary). Finish Basement, remodel main floor, new siding, windows, + shingles

7. Building Permit No. 170047 8. Year Built 1949

9. Date of Commencement of making the improvement 1/17/17

10. Estimated market value of property before improvement \$ 127,000

X 11. Cost of making the improvement (all labor, material and overhead) \$ 60,000

12. Estimated market value of property after improvement \$ 224,300

Applicant's Certification and Signature

X 13. I certify that the above information is correct to the best of my knowledge and I apply for this exemption.

Applicant's Signature Kevin Schiermeister Date 10/13/2017

Assessor's Determination

14. The local assessor finds that the improvements in this application has has not met the qualifications for exemption for the following reason(s): 5 YEARS FOR QUALIFYING WORK

Assessor's Signature Don Dushka Date 10/16/17

Action of Governing Body

15. Action taken on this application by local governing board of the county or city: Denied Approved

Approval subject to the following conditions: _____

Chairman of Governing Body _____ Date _____

CITY OF
Fargo
ASSESSMENT DEPARTMENT



October 16, 2017

Board of City Commissioners
City Hall
Fargo, ND 58102

Dear Commissioners:

Chapter 57-02.2 of the North Dakota Century Code provides for a property tax exemption for certain types of improvements made to existing buildings.

I have attached a copy of an application for real estate tax exemption of building improvements for the property at 513 24 Ave N as submitted by Mary A Bernier. A description of the property involved, types of improvements to be made, and assessment information are indicated on the application.

It is my opinion that the value of some of the improvements, referred to in the application, qualifies for the exemption. This exemption would be for the years 2018, 2019, 2020, 2021 & 2022.

The estimated annual tax revenue lost by granting the exemption, based upon the estimated cost of the improvements, would be about \$120 with the City of Fargo's share being \$20.

Sincerely,



Ben Hushka
City Assessor

hah
attachment

**Application For Property Tax Exemption For Improvements
To Commercial And Residential Buildings**
North Dakota Century Code ch. 57-02.2
(File with the local city or township assessor)

Property Identification

1. Name of Property Owner <u>Mary Bernier</u>	Phone No. <u>701 241 9142</u>
2. Address of Property <u>513 24 Aven</u>	
City <u>FARGO</u>	State <u>ND</u> Zip Code <u>58102</u>
3. Legal description of the property for which the exemption is being claimed. _____ <u>Lt16, B11C6 Louise S Newman</u>	
4. Parcel Number <u>01-2080-0099000</u> Residential <input checked="" type="checkbox"/> Commercial <input type="checkbox"/> Central Business District <input type="checkbox"/>	
5. Mailing Address of Property Owner <u>Same</u>	
City _____	State _____ Zip Code _____

Description Of Improvements For Exemption

6. Describe the type of renovating, remodeling or alteration made to the building for which the exemption is being claimed (attach additional sheets if necessary). <u>Reside Dwelling</u>	
7. Building Permit No. <u>171594</u>	8. Year Built <u>1955</u>
9. Date of Commencement of making the improvement <u>August 2017</u>	
10. Estimated market value of property before improvement	\$ <u>184,700</u>
11. Cost of making the improvement (all labor, material and overhead)	\$ <u>4,000</u>
12. Estimated market value of property after improvement	\$ <u>194,100</u>

Applicant's Certification and Signature

13. I certify that the above information is correct to the best of my knowledge and I apply for this exemption.	
Applicant's Signature <u>Mary A. Bernier</u>	Date <u>10-13-17</u>

Assessor's Determination

14. The local assessor finds that the improvements in this application has <input checked="" type="checkbox"/> has not <input type="checkbox"/> met the qualifications for exemption for the following reason(s): <u>5 YEARS FOR QUALIFYING WORK</u>	
Assessor's Signature <u>[Signature]</u>	Date <u>10/16/17</u>

Action of Governing Body

15. Action taken on this application by local governing board of the county or city: Denied <input type="checkbox"/> Approved <input type="checkbox"/>	
Approval subject to the following conditions: _____	
Chairman of Governing Body _____	Date _____

CITY OF
Fargo
ASSESSMENT DEPARTMENT

56

October 16, 2017

Board of City Commissioners
City Hall
Fargo, ND 58102

Dear Commissioners:

Chapter 57-02.2 of the North Dakota Century Code provides for a property tax exemption for certain types of improvements made to existing buildings.

I have attached a copy of an application for real estate tax exemption of building improvements for the property at 3137 24 Ave S as submitted by Stephen P & Shawn R Lind. A description of the property involved, types of improvements to be made, and assessment information are indicated on the application.

It is my opinion that the value of some of the improvements, referred to in the application, qualifies for the exemption. This exemption would be for the years 2018, 2019, & 2020.

The estimated annual tax revenue lost by granting the exemption, based upon the estimated cost of the improvements, would be about \$75 with the City of Fargo's share being \$10.

Sincerely,

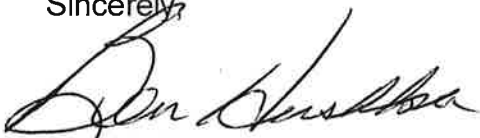

Ben Hushka
City Assessor

hah
attachment

**Application For Property Tax Exemption For Improvements
To Commercial And Residential Buildings**

North Dakota Century Code ch. 57-02.2
(File with the local city or township assessor)

Property Identification

1. Name of Property Owner Steve Lind Phone No. _____

2. Address of Property 3137 24 Ave S

City FARGO State ND Zip Code 58103

3. Legal description of the property for which the exemption is being claimed. Blk 1 Lot 10
Westlake 4th

4. Parcel Number 01-4008-00200-000 Residential Commercial Central Business District

5. Mailing Address of Property Owner 3137 24 Ave S

City Fargo State ND Zip Code 58103

Description Of Improvements For Exemption

6. Describe the type of renovating, remodeling or alteration made to the building for which the exemption is being claimed (attach additional sheets if necessary). bathroom remodel

7. Building Permit No. 170876 8. Year Built 1988

9. Date of Commencement of making the improvement August 2017

10. Estimated market value of property before improvement \$ 325,400

11. Cost of making the improvement (all labor, material and overhead) \$ 20,000 10,000 - 11,000

12. Estimated market value of property after improvement \$ 331,300

Applicant's Certification and Signature

13. I certify that the above information is correct to the best of my knowledge and I apply for this exemption.

Applicant's Signature Shawn Lind Date 10/9/2017

Assessor's Determination

14. The local assessor finds that the improvements in this application has not met the qualifications for exemption for the following reason(s): 3 YEARS, FOR QUALIFYING WORK

Assessor's Signature Don Husella Date 10/16/17

Action of Governing Body

15. Action taken on this application by local governing board of the county or city: Denied Approved

Approval subject to the following conditions: _____

Chairman of Governing Body _____ Date _____

TO: BOARD OF CITY COMMISSIONERS
FROM: EXECUTIVE ASSISTANT KEMBER ANDERSON *KA*
DATE: OCTOBER 16, 2017
SUBJECT: MEETING SCHEDULE FOR 2018

I am proposing the following schedule for City Commission meetings for calendar year 2018 (please note, if a meeting day falls on a holiday, the meeting will be held on Tuesday). Additionally, December 31st is New Year's Eve, so I am recommending that the Board meet on Wednesday, January 2nd:

January 2 (Tuesday), January 16 (Tuesday) and 29

February 12 and 26

March 12 and 26

April 9 and 23

May 7 and 21

June 4 and 18

July 2, 16 and 30

August 13 and 27

September 10 and 24

October 8 and 22

November 5 and 19

December 3, 17 and January 2 (Wednesday)

RECOMMENDED MOTION: To approve the 2018 City Commission meeting schedule as outlined above.

kamtgs18





Public Health
Prevent. Promote. Protect.
Fargo Cass Public Health

7

FARGO CASS PUBLIC HEALTH
1240 25th Street South
Fargo, ND 58103-2367
Phone 701-241-1360
Fax 701-241-1366
FargoCassPublicHealth.com

M E M O R A N D U M

TO: BOARD OF CITY COMMISSIONERS

FROM: RUTH ROMAN
DIRECTOR OF PUBLIC HEALTH

DATE: OCTOBER 13, 2017

RE: GRANT AGREEMENT WITH DAKOTA MEDICAL FOUNDATION
FOR \$15,300 TO SUPPORT SMART LUNCHROOM MOVEMENT

The attached grant agreement with the Dakota Medical Foundation is for continued support of the Smart Lunchroom project that is part of SchoolsAlive!

The following budget adjustments are required for this contract:

2017 Revenue		
DMF School Wellness	101-0000-337-50-00	\$3,750
2017 Expense		
Contract	101-6035-451-38-11	\$3,750

If you have any questions, please call me at 241-1380.

Suggested Motion: Move to approve the grant agreement with the Dakota Medical Foundation for the SchoolAlive Project.

RR/la
Enclosure





GRANT AGREEMENT
by and between

DAKOTA MEDICAL FOUNDATION/DAKOTA MEDICAL CHARITIES
and

GRANT PARTNER: FARGO CASS PUBLIC HEALTH

**ADDRESS: 1240 25th Street S
Fargo, ND 58103**

CONTACT PERSON: Kim Lipetzky

GRANT AMOUNT: \$15,300

**PROJECT TITLE: Smarter Lunchrooms Movement (\$5,000) and Consulting
Services (\$10,300)**

**PROJECT DESCRIPTION: Partner with South East Education Cooperative (SEEC) to train
school nutrition professionals on the Smarter Lunchroom
Movement, and contract with registered dietician consulting
services to support Smarter Lunchroom principles.**

- 1. Achieve Smarter Lunchroom Implementation in all Cass County schools by September 30, 2021.**
- 2. In year one, work with 25% of Cass County schools (approximately 13 schools) to continue to build, sustain, and support implementation of Smarter Lunchroom strategies.**
- 3. Continue support for Smarter Lunchroom principles to create and promote healthy environments in schools.**
- 4. Attend workshops to acquire relevant information and updates on school wellness policies and Smarter Lunchroom principles to share with SchoolsAlive! partners.**
- 5. Share pertinent Child Nutrition program updates with SchoolsAlive! partners, and assist with additional SchoolsAlive! projects as needed.**
- 6. Survey school Food Service Directors to assess needs and commonly accepted timing for continuing education and training.**
- 7. Enhance Smarter Lunchroom trainings.**
- 8. Plan and host Nutrition Service Directors' and Managers' gatherings at least 5 times during the 2017-2018 school year.**

PROJECT START DATE: October 1, 2017

PROJECT END DATE: September 30, 2018

PAYMENT SCHEDULE: October 15, 2017 \$15,300

**REPORTING SCHEDULE
AND REQUIREMENTS:**

Provide brief monthly progress updates to Dakota Medical Foundation via email to Pat Traynor (pattraynor@dakmed.org) and Andrea Feigum (andreafeigum@dakmed.org).

MONTHLY REPORTS: Due on or around the 7th of each month

FINAL REPORT: Due September 30, 2018

To include:

1. Report on school district or building Smarter Lunchroom goals and implementation of those goals.
2. Report of outcomes of each School Nutrition Service Directors' gathering(s).
3. Report on outcomes of School Nutrition Service Managers' gathering(s).
4. Budget expenditure report for contracted services including number of hours contracted.

THIS AGREEMENT ("Agreement") by and between Dakota Medical Foundation/Dakota Medical Charities ("Foundation") and Fargo Cass Public Health ("Grant Partner") is effective on the **1st of October, 2017** ("Effective Date").

The Foundation and the Grant Partner agree as follows:

I. USE OF GRANT FUNDS, GRANT CHANGES/AMENDMENTS

A. Authorized Use of Grant Funds.

1. Grant Partner must expend the grant funds solely for tax exempt 501(c)(3) charitable and/or educational purposes and/or governmental purposes as defined by the U.S. Internal Revenue Code to carry out the project entitled **Smarter Lunchrooms Movement**. Grant funds shall only be expended in accordance with the specifications and time frame contained in the Grant Application.
2. No part of the grant shall be used:
 - a. To carry on propaganda or otherwise to attempt to influence legislation within the meaning of Code section 4945(d)(1);
 - b. To influence the outcome of any specific public election, or to carry on (directly or indirectly) any voter registration drive within the meaning of Code section 4945(d)(2);
 - c. To make any grants which do not comply with the individual grant requirements of Code section 4945(d)(3) or the organizational grant requirements of Code section 4945(d)(4);
 - d. To undertake any activity for any purpose other than a charitable purpose specified in Code section 170(c)(2)(b); or
 - e. To provide material support or resources to any individual or entity that it knows, or has reason to know, is an individual or entity that advocates, plans, sponsors, engages in, or has engaged in terrorist activity.

B. Grant Changes/Amendments.

1. Grant Partner shall notify the Foundation **prior to** deviations from the original application including, but not limited to, changes in: project purpose, timeline, budget, or personnel. Such amendments, changes, or modifications shall be effective only upon written approval by the Foundation. Failure to notify the Foundation of deviations may result in grant termination and repayment of any expenditures associated therewith.
2. The Grant Partner **is allowed** to implement a **ten-percent variance between budget line items** without Foundation approval. It is understood that the variance is an adjustment **between** budget line items only and will not increase the overall grant budget.

II. **REPORTS**

A. **Grant Reports/Performance Monitoring/Evaluation.**

1. The Grant Partner agrees to submit interim and final reports to the Foundation according to the schedule set forth in this agreement including and without limitation: 1) a financial report comparing the amounts actually expended for each item with the budgeted amount approved by the Foundation and 2) a final report upon completion of the grant period. Grant Partners who fail to submit required reports will not be eligible for future funding from the Foundation.
2. Grant Partner shall also submit any other grant reports requested by the Foundation, within a reasonable time period, utilizing the format designated by the Foundation. Grant Partner shall also supply the Foundation with information necessary or desirable to permit the Foundation to review the grant's use and its effect on the public status of Grant Partner.
3. The Grant Partner understands that Foundation staff may schedule site visits as part of its regular monitoring and evaluation process.

B. **Authorized Agent.** For purposes of administration of the reporting and compliance provisions of this agreement, the Foundation's authorized agent is J. Patrick Traynor, President.

C. **Changes in Financial Position/Management Team/Organizational Structure.**

1. **Grant Partner shall notify the Foundation immediately if there is any substantial negative change in Grant Partner's financial position, management team members, or organizational structure.** Grant Partner shall supply the Foundation, upon its request, with any information as may be necessary or desirable to permit the Foundation to review Grant Partner's financial status, management team and/or organizational structure.

D. **Conflicts of Interest Disclosure Form.** Grant Partner acknowledges that Grant Partner must continuously disclose Grant Partner's potential conflicts of interest with the Foundation so that the Foundation can protect its tax-exempt status by avoiding transactions, arrangements, or uses of the Foundation's funds that might unreasonably benefit the private interests of Grant Partner or any individual, including benefits to Grant Partner's related persons, which include without limitation, Grant Partner's directors, trustees, officers, committee members, agents, contractors, key employees, and/or anyone acting on Grant Partner's behalf in any capacity, or immediate family members thereof.

Thus, the President/Executive Director (or equivalent thereof) of Grant Partner, and the President/Chair (or equivalent thereof) of the board of directors of Grant Partner shall complete or arrange for the completion of the attached Foundation Conflicts of Interest Disclosure Form ("form") and shall have a continuing obligation to immediately update the form if at any time throughout the grant period there is new information to report on the form.



(Initial here)

I've read the above paragraph and understand our obligations relating to conflicts of interest.

III. **TERMINATION AND REPAYMENT**

A. **Termination.** This Agreement shall automatically terminate at the project end date provided that all obligations which are by their nature continuing, including without limitation Sections II., III. A., IV., V. A.-E. and VI. B., shall survive any expiration or termination of this Agreement. This Agreement may be terminated by the Foundation at any time upon written notice to Grant Partner for any reason, including but not limited to: 1) The Foundation is not satisfied, in its sole discretion, with the performance of the project, Grant Partner's financial status, changes in organizational structure or management team members, or 2) Grant Partner fails to comply with one or more conditions of this Agreement. If this Agreement is

terminated prior to the scheduled completion of the project the Grant Partner shall provide the Foundation with a full accounting of the grant amount, including without limitation, a description of all expenses relating to the project and receipts for grant funds expended.

B. Repayment.

1. If grants funds have not been completely expended by the project end date, the Grant Partner may return the unspent funds to the Foundation or provide an accounting of the unspent balance and a proposed plan to expend the remaining funds. If the Foundation does not approve the proposed plan to expend the grant funds beyond the original grant period, the Grant Partner agrees to repay the unspent balance within 30 days of written notice by the Foundation.
2. Within 30 days after demand by the Foundation, Grant Partner shall repay to the Foundation the amount requested to be repaid, including any interest earned thereon, in the event that the Foundation, in its sole discretion, determines that the Grant Partner:
 - a. has violated the terms of this Grant Agreement or prior Grant Applications or Grant Agreements; or
 - b. has made an unauthorized use of grant funds; or
 - c. has changed the purpose of the project, failed to conduct the specified project within the time frame set forth, or within the budget parameters set forth; or
 - d. has changed its charitable purposes, or has ceased to be exempt under Section 501(c)(3) of the Code, or has ceased to be a public charity or operation foundation as described in Sections 509 and 4942 of the Code, respectively.

Repayment will not be required as to funds properly expended pursuant to the terms of this Agreement through the date of receipt of written notice of termination to Grant Partner.

IV. ACCOUNTING

- A. **Accounts and Records.** Grant Partner shall establish and maintain accurate and complete accounts and financial or other records in relation to the receipt and expenditure of any and all grant funds for the project so they adequately show that the grant funds were used exclusively for the purposes described in this agreement.

Whether or not Grant Partner maintains a separate bank account, this grant should be treated as a "restricted fund" and no part of it shall be used for purposes other than those designated for this grant.

These project accounts and records shall be retained by the Grant Partner from the Effective Date of this Agreement and for at least three (3) years following the project end date.

- B. **Audit.** The project accounts and records of the Grant Partner shall be audited in the same manner as all other accounts and records of the Grant Partner are audited. The Grant Partner's project accounts and records (including but not limited to accounts and records relating to the project) may be audited and/or inspected on the Grant Partner's premises or otherwise by individuals or organizations designated and authorized by the Foundation at any time during the period specified in this grant agreement and within three years thereafter.

V. GENERAL CONDITIONS

A. **Publicity/Acknowledgement.**

1. The Foundation encourages you to publicize this grant. The Grant Partner shall refer to the Foundation in any printed publicity related to the grant award or the project supported by the grant. However, please do not issue press releases, public announcements or news articles without first consulting the Foundation. The Foundation will review and

approve or revise releases. Grant Partner agrees to make any reasonable changes suggested by the Foundation.

2. Foundation funding should be acknowledged on all graphic material, programs and other publications related to the project.
3. If representatives of your organization are interviewed by news media about activities supported by this grant, we would appreciate your citing the support of the Foundation.
4. Oral acknowledgement should be given at any event for which there is no printed material.
5. Please include in your grant reports copies of any coverage this grant receives in newspapers, newsletters, or other publications.

B. Right to Use Name.

The Grant Partner authorizes the Foundation to use the name of the Grant Partner and project partners as part of press releases, brochures, newsletters, and other publications prepared for the purpose of public education and information, and to demonstrate the Foundation's scope of grantmaking. The use of the name of the Grant Partner in our publications is for example only and does not convey or imply that the Foundation will make future awards to the Grant Partner.

C. Copyright, Foundation Use of Data and Public Use Data Types.

1. All copyright interests in materials produced as a result of this grant are owned by the grant partner. The Grant Partner grants to the Foundation a nonexclusive, irrevocable, perpetual, royalty-free license to reproduce, publish, republish, summarize, excerpt or otherwise use and license to others to use, in print or electronic form, including in electronic databases or in any future form not yet discovered or implemented, any and all such materials produced in connection with this grant.
2. The Grant Partner represents and warrants that the material produced by the Grant Partner under this grant will be original and not infringe upon any copyright or any other right of any other person, and has not previously been published.

D. Privacy and Security of Health Information. The Grant Partner represents and warrants that any individually identifiable health information used or disclosed in connection with the grant will be obtained in compliance with applicable statutes and regulations regarding the privacy and security of such information, including but not limited to the Health Information Portability and Accountability Act of 1996, 42 U.S.C. Section 201 et seq (42 U.S.C. Section 1320d-1320d-8), and that in any reporting to the Foundation, such data will be de-identified within the meaning of the HIPAA privacy rule or will be otherwise permissible by law.

E. Defense; Indemnification. Grant Partner hereby agrees to indemnify, defend and hold harmless the Foundation and its officers, directors, employees and agents from any liability, damage, loss or expense (including reasonable attorney fees and expenses of litigation) incurred or imposed upon the Foundation in connection with any claims, suits, actions, demands, or judgments arising out of or connected with the project or the grant. Grant Partner shall promptly notify the Foundation of any such claim, and shall cooperate with the Foundation in defense of the claim. Grant Partner agrees, at its own expense, to engage counsel approved in writing by the Foundation to assist in defense of such claim.

F. Binding Agreement and Assignment. Except as otherwise provided in this agreement, Grant Partner shall perform within its own organization the work provided for under this Agreement and shall not assign, subcontract, sublet, or transfer any of the work described without receiving written consent from the Foundation. This Agreement shall inure to the benefit of and be binding on the Foundation and Grant Partner and its successors and assignees, if any.

- G. **Independent Parties.** The relationship between Grant Partner and Foundation is that of independent contractors and not that of principal and agent, employer and employee, partnership or joint ventures. No party hereto has the authority to bind the other party without express written authorization of the other party.
- H. **No Third Party Rights.** It is the explicit intention of the parties that no person or entity other than the parties is or shall be entitled to bring any action to enforce any provision of this Agreement, and that the covenants and agreements set forth in this Agreement shall be solely for the benefit of and enforceable only by the parties or their respective successors and assigns as permitted hereunder.
- I. **Qualifying Distribution.** The Grant Partner agrees to take such further actions reasonably requested by the Foundation, and to comply with the provisions of any future regulations promulgated under Code sections 4942 or 4945 that are applicable to the grant, to ensure that the grant: a) will constitute a "qualifying distribution" by the Foundation within the meaning of Code section 4942(g), b) will not constitute a "taxable expenditure" by the Foundation within the meaning of Code section 4945, and c) will not violate the USA Patriot Act (Public Law 107-56), Executive Order 13224, or any other applicable United States law, regulation, or order.
- J. **Venue.** This Agreement is governed by the laws of the State of North Dakota.

VI. GRANT PARTNER'S TAX STATUS

A. Initial one of the following representations:

_____ Grant Partner hereby represents and warrants that it is exempt from federal income tax under Section 501(a) of the Internal Revenue Code of 1986, as amended (the Code) and as described in Section 501(c)(3) of the Code, and that its determination letters from the Internal Revenue Service ("Service") are still valid and have not been revoked.

RR

Grant Partner hereby represents and warrants that it is a governmental entity operated for public purposes.

_____ Grant Partner is not exempt from federal income tax under Section 501(a) of the Code as described in Section 501(c)(3) of the Code, and is not a governmental entity for public purposes. Grant Partner hereby represents and warrants that its tax status is _____ (e.g. "exempt under Section 501(c)(6)" or "not exempt"). Grant Partner shall use the funds as required herein in support of the Foundation's exempt purposes.

B. Grant Partner shall notify the Foundation immediately if there is any pending or actual change in the Grant Partner's tax status.

By signing the space provided below, you represent and warrant that you have full power and authority to enter into this agreement and that your organization agrees to comply with the foregoing terms.

IN WITNESS WHEREOF, the parties have caused this Agreement to be executed by their duly authorized representatives.

FARGO CASS PUBLIC HEALTH

By: Ruth Roman
Signature of President/Executive Director
(or equivalent thereof) of Grant Partner

Ruth Roman
(Please print name of above signature)

Title: Director of Public Health

Date: October 13, 2017

By: _____
Signature of President/Chair (or equivalent thereof)
of the Board of Directors of Grant Partner

Timothy J. Mahoney
(Please print name of above signature)

Title: Mayor, City of Fargo

Date: _____

**DAKOTA MEDICAL FOUNDATION/
DAKOTA MEDICAL CHARITIES**

J. Patrick Traynor
J. Patrick Traynor, President

Date: 10/11/17



**DAKOTA MEDICAL FOUNDATION/DAKOTA MEDICAL CHARITIES
ORGANIZATIONAL ENTITY GRANT PARTNER
CONFLICTS OF INTEREST DISCLOSURE FORM**

Grant Partner acknowledges that Grant Partner must continuously disclose Grant Partner's potential conflicts of interest with Dakota Medical Foundation/Dakota Medical Charities ("Foundation") so that the Foundation can protect its tax-exempt status by avoiding transactions, arrangements, or uses of the Foundation's funds that might unreasonably benefit the private interests of any individual or Grant Partner, including benefits to Grant Partner and Grant Partner's related persons, which include without limitation, Grant Partner's directors, trustees, officers, committee members, agents, contractors, key employees, and/or anyone acting on Grant Partner's behalf in any capacity or immediate family members thereof.

Thus, the President/Executive Director (or equivalent thereof) of Grant Partner, and the President/Chair (or equivalent thereof) of the Board of Directors of Grant Partner, shall complete, or arrange for the completion of this Foundation Conflicts of Interest Disclosure Form ("form") and shall have a continuing obligation to immediately update the form if at any time throughout the grant period there is new information to report on the form.

Potential Conflicts

I acknowledge that the Foundation must be informed about any potential conflicts of interest any individual or Grant Partner, Grant Partner's related persons, and/or anyone acting on grant Partner's behalf in any capacity may have with the Foundation and any of the Foundation's officers, directors and staff, including without limitation, any opportunities that Grant Partner and/or Grant Partners related persons or any individual may have to direct the use of the Foundation's funds directly or indirectly to any of Grant Partner's related persons or their immediate family members, any individual, or any organization in which Grant Partner or Grant Partner's related persons may have a financial interest or position of control.

I have the following concerns about any potential conflicts of interest that Grant Partner or Grant Partner's related persons may have with the Foundation and any of its officers, directors and staff:

I have, to the best of my knowledge, disclosed all potential or actual conflicts of interest with the Foundation. I agree to immediately report to the Foundation any changes in my above representations.

Ruth Roman
Signature of President/Executive Director
(or equivalent thereof) of Grant Partner

October 13, 2017
Date

Signature of President/Chair (or equivalent thereof)
of the Board of Directors of Grant Partner

Date



Public Health
Prevent. Promote. Protect.
Fargo Cass Public Health

8

FARGO CASS PUBLIC HEALTH
1240 25th Street South
Fargo, ND 58103-2367
Phone 701-241-1360
Fax 701-241-1366
FargoCassPublicHealth.com

M E M O R A N D U M

TO: BOARD OF CITY COMMISSIONERS

FROM: RUTH ROMAN
DIRECTOR OF PUBLIC HEALTH

DATE: OCTOBER 19, 2017

RE: CONTRACT WITH THE NORTH DAKOTA DEPARTMENT OF HUMAN SERVICES FOR SUBSTANCE ABUSE PREVENTION CONTRACT NO. #810-10846 CFDA NO. N/A, \$95,000

This is a request to approve the attached Purchase of Service Agreement with the North Dakota Department of Human Services, Behavioral Health Division for community outreach program.

The following budget adjustment is required for this contract:

2017 Expense:

General Supplies	101-6012-451-61-40	\$ 3,669
Capital Outlay-Machinery & Equipment	101-6012-451-74-10	\$10,725
Capital Outlay-Vehicle	101-6012-451-74-20	\$27,150

2017 Revenue:

NDDoHS Detox	New Number	\$49,976
--------------	------------	----------

If you have questions, please contact Ruth Roman at 241-1380.

Suggested Motion: Move to approve the contract with the North Dakota Department of Human Service for the community outreach program.

RR/la
Enclosure



PURCHASE OF SERVICE AGREEMENT

The state of North Dakota, acting through its North Dakota Department of Human Services, Behavioral Health Division (State), has determined the services identified in the Scope of Service paragraph below should be purchased.

City of Fargo (Vendor), 1240 25th Street South, Fargo, ND 58103, proposes to provide those services.

State and Vendor therefore enter into the following:

1. TERM OF THE AGREEMENT

This Agreement runs from September 1, 2017, through September 30, 2019. This Agreement will not automatically renew.

2. SCOPE OF SERVICE

Vendor shall develop and implement a community outreach program to provide assistance to individuals needing intoxication or withdrawal management services based on best practices that are recovery oriented, trauma-informed, and person centered. The goal of the program is to assist individuals who are intoxicated and in crisis situations to receive appropriate services and engagement for possible treatment while decreasing their need for ambulance trips due to intoxication, inappropriate emergency rooms stays, and unnecessary interactions with law enforcement. Vendor shall develop an advisory committee consisting of local community representatives, such as local first responders, hospital emergency room representatives, the Withdrawal Management Unit, and other public and private treatment providers to advise Vendor in the development, implementation, and evaluation of program. Vendor shall create procedures adhering to state and federal regulations to respond to situations, when possible, involving individuals who are under the influence of substances and submit to State for approval. Vendor shall purchase a vehicle to conduct outreach and engagement services with special additions, such as radios and estimated arrive time - tracking device consistent with local community stakeholders. Vendor shall also ensure the program is staffed appropriately. Training for staff shall include a minimum of substance use disorders, intoxication and withdrawal management, recovery oriented and trauma-informed care, and overdose prevention, including the administration of naloxone. Vendor shall provide State with monthly data reports, including process and outcome measures. Vendor shall attend meetings and training requested by State.

3. COMPENSATION

State, upon receipt and approval of SFN 1763 Request for Reimbursement, monthly reports, and any additional information requested, shall pay Vendor no more than \$45,000 for an outreach vehicle, including special additions, such as radios and estimated arrive time, with a purchase date no later than September 30, 2017, and \$2,000 monthly for program implementation. Total payment under this

Agreement may not exceed \$95,000. Vendor shall submit its request for reimbursement to State monthly. Vendor shall submit its final payment request to State no later than 10 days after the expiration or termination of this Agreement.

4. TERMINATION

a. Termination by Mutual Agreement or Notice

This Agreement may be terminated at any time by mutual consent of both parties executed in writing, or upon 30-days' written notice by either party, with or without cause.

b. Early Termination in the Public Interest

State is entering into this Agreement for the purpose of carrying out the public policy of the state of North Dakota, as determined by its Governor, Legislative Assembly, and Courts. If this Agreement ceases to further the public policy of the state of North Dakota, State, in its sole discretion, by written notice to Vendor, may terminate this Agreement in whole or in part.

c. Termination for Lack of Funding or Authority

State may terminate the whole or any part of this Agreement, effective upon delivery of written notice to Vendor or on any later date stated in the notice, under any of the following conditions:

- 1) If funding from federal, state, or other sources is not obtained and continued at levels sufficient to allow for purchase of the services or supplies in the indicated quantities or term.
- 2) If federal or state laws or rules are modified or interpreted in a way that the services are no longer allowable or appropriate for purchase under this Agreement or are no longer eligible for the funding proposed for payments authorized by this Agreement.
- 3) If any license, permit, or certificate required by law or rule, or by the terms of this Agreement, is for any reason denied, revoked, suspended, or not renewed.

Termination of this Agreement under this subsection is without prejudice to any obligations or liabilities of either party already accrued prior to termination.

d. Termination for Cause

State may terminate this Agreement effective upon delivery of written notice to Vendor, or any later date stated in the notice:

- 1) If Vendor fails to provide services required by this Agreement within the time specified or any extension agreed to by State; or

- 2) If Vendor fails to perform any of the other provisions of this Agreement, or so fails to pursue the work as to endanger performance of this Agreement in accordance with its terms.

The rights and remedies of State provided in this section are not exclusive and are in addition to any other rights and remedies provided by law or under this Agreement.

5. NONPERFORMANCE

Failure by Vendor to perform the terms of this Agreement constitutes a breach of contract and will result in the termination of the Agreement. If a breach by Vendor renders the Agreement impossible of performance by Vendor and is caused by circumstances beyond the control of Vendor, and through no fault of Vendor, the Agreement will be terminated and State may set off, against any liability or obligations owed to Vendor under this Agreement or otherwise, any amounts paid for individual items of work which are incomplete at the time of the breach.

6. FORCE MAJEURE

Vendor shall not be held responsible for delay or default caused by fire, flood, riot, acts of God, or war if the event is beyond Vendor's reasonable control, and Vendor gives notice to State immediately upon occurrence of the event that caused, or is reasonably expected to cause, the delay or default.

7. VENDOR'S UNDERSTANDING OF TERM OF FUNDING

Vendor understands that this Agreement is a one-time agreement, and acknowledges that it has received no assurances that this Agreement may be extended beyond its expiration date.

8. VENDOR ASSURANCES

This Agreement will be construed according to the laws of the state of North Dakota. In connection with furnishing supplies or performing work under this Agreement, persons who contract with or receive funds to provide services to State are obligated and agree to comply with all local, state, and federal laws, regulations, and executive orders related to the performance of this Agreement, including the following: Fair Labor Standards Act, Equal Pay Act of 1963, Titles VI and VII of the Civil Rights Act of 1964, the Age Discrimination in Employment Act of 1967, the North Dakota Human Rights Act, the Comprehensive Alcohol Abuse and Alcoholism Prevention, Treatment, and Rehabilitation Act of 1970, the Drug Abuse Prevention, Treatment, and Rehabilitation Act of 1970, Section 504 of the Rehabilitation Act of 1973, the Age Discrimination Act of 1975, the Drug-Free Workplace Act of 1988, the Americans with Disabilities Act of 1990, Alcohol, Drug Abuse, and Mental Health Administration Reorganization Act of 1992, and the Pro-Children Act of 1994.

By signing this Agreement Vendor certifies that neither Vendor, Subcontractor, nor their principals are presently debarred, declared ineligible, or voluntarily excluded from participation in transactions with the state or federal government by any department or agency of the state or federal government.

Vendor must be an approved vendor with the Office of Management and Budget within the state of North Dakota as required by North Dakota Century Code § 54-44.4-09.

9. AUTHORITY TO CONTRACT

Vendor may subcontract with qualified vendors of services, provided that any subcontract acknowledges the binding nature of this Agreement, and incorporates this Agreement, together with its attachments, as appropriate. Vendor is solely responsible for the performance of any subcontractor. Vendor may not contract for or on behalf of or incur obligations on behalf of State. Vendor may not assign or otherwise transfer or delegate any right or duty without State's express written consent.

10. INDEPENDENT ENTITY

Vendor is an independent entity under this Agreement. Vendor, its employees, agents, or representatives are not employees of State for any purpose, including the application of the Social Security Act, the Fair Labor Standards Act, the Federal Insurance Contribution Act, the Federal Unemployment Act, the North Dakota Unemployment Compensation Law, and the North Dakota Workforce Safety and Insurance Act. No part of this Agreement may be construed to represent the creation of an employer/employee relationship between State and Vendor. Vendor retains sole and absolute discretion in the manner and means of carrying out Vendor's activities and responsibilities under this Agreement, except to the extent specified in this Agreement.

11. INDEMNITY

State and Vendor each agree to assume their own liability for any and all claims of any nature, including all costs, expenses, and attorneys' fees which may in any manner result from or arise out of this Agreement.

12. INSURANCE

Vendor shall secure and keep in force during the term of this Agreement, from insurance companies, government self-insurance pools, or government self-retention funds, authorized to do business in North Dakota, the following insurance coverages:

- 1) Commercial general liability, including premises or operations, contractual, and products or completed operations coverages (if applicable), with minimum liability limits of \$250,000 per person and \$500,000 per occurrence.
- 2) Automobile liability, including Owned (if any), Hired, and Non-Owned automobiles, with minimum liability limits of \$250,000 per person and \$500,000 per occurrence.

- 3) Workers compensation coverage meeting all statutory requirements.

The insurance coverages listed above must meet the following additional requirements:

- 1) Any deductible or self-insured retention amount or other similar obligation under the policies shall be the sole responsibility of the Vendor. The amount of any deductible or self-retention is subject to approval by the State.
- 2) This insurance may be in policy or policies of insurance, primary and excess, including the so-called umbrella or catastrophe form and must be placed with insurers rated "A-" or better by A.M. Best Company, Inc., provided any excess policy follows form for coverage. Less than an "A-" rating must be approved by the State. The policies shall be in form and terms approved by the State.
- 3) The insurance required in this Agreement, through a policy or endorsement, shall include a provision that the policy and endorsements may not be canceled or modified without 30 days' prior written notice to the undersigned State representative.
- 4) Vendor shall furnish a certificate of insurance to the undersigned State representative prior to commencement of this Agreement.
- 5) Failure to provide insurance as required in this Agreement is a material breach of contract entitling State to terminate this Agreement immediately.

13. NOTICE

Any notice or other communication required under this Agreement must be given by registered or certified mail and is complete on the date mailed when addressed to the parties at the following addresses:

City of Fargo
1240 25th Street South
Fargo, ND 58103

OR ND Department of Human Services
Behavioral Health Division
1237 W. Divide Ave, Suite 1D
Bismarck, ND 58501

Notice provided under this provision does not meet the notice requirements for monetary claims against State found at North Dakota Century Code § 32-12.2-04.

14. INTEGRATION, MODIFICATION, AND CONFLICT IN DOCUMENTS

This Agreement constitutes the entire Agreement between Vendor and State. There are no understandings, agreements, or representations, oral or written, not specified within this Agreement. No alteration, amendment, or modification of this Agreement is effective unless it is reduced to writing, signed by the parties, and attached to the Agreement.

If any inconsistency exists between this Agreement and other provisions of collateral contractual agreements which are made a part of this Agreement by reference or otherwise, the provisions of this Agreement control.

15. SEVERABILITY

If any term of this Agreement is declared by a court having jurisdiction to be illegal or unenforceable, the validity of the remaining terms will not be affected and, if possible, the rights and obligations of the parties are to be construed and enforced as if the Agreement does not contain the illegal or unenforceable term.

16. APPLICABLE LAW AND VENUE

This Agreement is governed by and construed according to the laws of the state of North Dakota. Any action to enforce this Agreement must be adjudicated exclusively in the state District Court of Burleigh County, North Dakota. Each party consents to the exclusive jurisdiction of such court and waives any claim of lack of jurisdiction or *forum non conveniens*.

17. ASSIGNMENT

Neither party may assign this Agreement or the party's rights under this Agreement without the written approval of the other party. Approval to assign may not be unreasonably withheld. This Agreement is equally binding on the respective parties and their successors and assigns.

18. SPOILIATION – PRESERVATION OF EVIDENCE

Vendor shall promptly notify State of all potential claims that arise or result from this Agreement. Vendor shall also take all reasonable steps to preserve all physical evidence and information that may be relevant to the circumstances surrounding a potential claim, while maintaining public safety, and grants to State the opportunity to review and inspect the evidence, including the scene of an accident.

19. WORKS FOR HIRE

Vendor acknowledges that all work(s) under this Agreement is "work(s) for hire" within the meaning of the United States Copyright Act (Title 17 United States Code) and hereby assigns to State all rights and interests Vendor may have in the work(s) it prepares under this Agreement, including any right to derivative use of the work(s). All software and related materials developed by Vendor in performance of this Agreement for State shall be the sole property of State, and Vendor hereby assigns and transfers all its right, title, and interest therein to State. Vendor shall execute all necessary documents to enable State to protect State's intellectual property rights under this section.

20. WORK PRODUCT, EQUIPMENT, AND MATERIALS

All work product, equipment, and materials created for State or purchased by State under this Agreement belong to State and must be delivered to State at State's request upon expiration or termination of this Agreement.

21. CONFIDENTIAL INFORMATION

Vendor shall not use or disclose any information it receives from State under this Agreement that State has previously identified as confidential or exempt from mandatory public disclosure except as necessary to carry out the purposes of this Agreement or as authorized in advance by State. State shall not disclose any information it receives from Vendor that Vendor has previously identified as confidential and that State determines, in its sole discretion, is protected from mandatory public disclosure under a specific exception to the North Dakota open records law found in North Dakota Century Code chapter 44-04. The duty of State and Vendor to maintain confidentiality of information under this section continues beyond the term of this Agreement, including any extensions or renewals.

22. COMPLIANCE WITH PUBLIC RECORDS LAWS

Vendor understands that, except for disclosures prohibited in this Agreement, State must disclose to the public upon request any records it receives from Vendor. Vendor further understands that any records obtained or generated by Vendor under this Agreement, except for records that are confidential under this Agreement, may be open to the public upon request under certain circumstances under the North Dakota open records law. Vendor agrees to contact State immediately upon receiving a request for information under the open records law and to comply with State's instructions on how to respond to the request.

23. ATTORNEY FEES

If a lawsuit is filed by State to obtain performance due under this Agreement, and State is the prevailing party, Vendor shall pay State's reasonable attorney fees and costs in connection with the lawsuit, except when prohibited by North Dakota Century Code § 28-26-04.

24. ALTERNATIVE DISPUTE RESOLUTION – JURY TRIAL

State does not agree to any form of binding arbitration, mediation, or other forms of mandatory alternative dispute resolution. The parties may enforce their rights and remedies in judicial proceedings. State does not waive any right to a jury trial.

25. NONDISCRIMINATION AND COMPLIANCE WITH LAWS

Vendor shall comply with all laws, rules, and policies, including those relating to nondiscrimination, accessibility, and civil rights. Vendor shall timely file all required reports, make required payroll deductions, and timely pay all taxes and premiums owed, including sales and use taxes, unemployment compensation, and workers' compensation premiums. Vendor also shall have and keep current at all times during the term of this Agreement all licenses and permits required by law.

26. ACCESS TO BOOKS AND RECORDS

Vendor shall provide State, the federal government, and their duly authorized representatives access to the books, documents, papers, and records of Vendor, which are pertinent to the services provided under this Agreement, for the purpose of making an audit or examination, or for making excerpts and transcripts. All records, regardless of physical form, and the accounting practices and procedures of Vendor relevant to this Agreement are subject to examination by the North Dakota State Auditor, the Auditor's designee, or federal auditors. Vendor shall maintain all of these records for at least three years following completion of this Agreement and be able to provide them at any reasonable time. State, State Auditor, or Auditor's designee shall provide reasonable notice.

CITY OF FARGO

By Ruth Roman
Ruth Roman
By Director of Public Health

By _____ DATE
Timothy J. Mahoney
Its Mayor, City of Fargo

Date October 19, 2017

45-6002069
Vendor's Federal Taxpayer Identification Number

STATE OF NORTH DAKOTA

NORTH DAKOTA DEPARTMENT OF HUMAN SERVICES

By _____ DATE
PAMELA SAGNESS, DIRECTOR
BEHAVIORAL HEALTH DIVISION

By _____ DATE
AMY JANGULA JOHNSON
CONTRACT OFFICER
Approved for form and content



9

FARGO CASS PUBLIC HEALTH
 1240 25th Street South
 Fargo, ND 58103-2367
 Phone 701-241-1360
 Fax 701-241-1366
 FargoCassPublicHealth.com

M E M O R A N D U M

TO: BOARD OF CITY COMMISSIONERS

**FROM: RUTH ROMAN
 DIRECTOR OF PUBLIC HEALTH**

DATE: OCTOBER 19, 2017

**RE: CONTRACT WITH THE NORTH DAKOTA DEPARTMENT OF
 HUMAN SERVICES FOR SUBSTANCE ABUSE PREVENTION
 CONTRACT NO. #810-10846 CFDA NO. N/A, \$95,000**

This is a request to approve the attached Purchase of Service Agreement with the North Dakota Department of Human Services, Behavioral Health Division for community outreach program.

The following budget adjustment is required for this contract:

2018 Revenue:		
NDDoHS Detox	New Number	\$25,728

If you have questions, please contact Ruth Roman at 241-1380.

Suggested Motion: Move to approve the contract with the North Dakota Department of Human Service for the community outreach program.

RR/la
Enclosure



PURCHASE OF SERVICE AGREEMENT

The state of North Dakota, acting through its North Dakota Department of Human Services, Behavioral Health Division (State), has determined the services identified in the Scope of Service paragraph below should be purchased.

City of Fargo (Vendor), 1240 25th Street South, Fargo, ND 58103, proposes to provide those services.

State and Vendor therefore enter into the following:

1. TERM OF THE AGREEMENT

This Agreement runs from September 1, 2017, through September 30, 2019. This Agreement will not automatically renew.

2. SCOPE OF SERVICE

Vendor shall develop and implement a community outreach program to provide assistance to individuals needing intoxication or withdrawal management services based on best practices that are recovery oriented, trauma-informed, and person centered. The goal of the program is to assist individuals who are intoxicated and in crisis situations to receive appropriate services and engagement for possible treatment while decreasing their need for ambulance trips due to intoxication, inappropriate emergency rooms stays, and unnecessary interactions with law enforcement. Vendor shall develop an advisory committee consisting of local community representatives, such as local first responders, hospital emergency room representatives, the Withdrawal Management Unit, and other public and private treatment providers to advise Vendor in the development, implementation, and evaluation of program. Vendor shall create procedures adhering to state and federal regulations to respond to situations, when possible, involving individuals who are under the influence of substances and submit to State for approval. Vendor shall purchase a vehicle to conduct outreach and engagement services with special additions, such as radios and estimated arrive time - tracking device consistent with local community stakeholders. Vendor shall also ensure the program is staffed appropriately. Training for staff shall include a minimum of substance use disorders, intoxication and withdrawal management, recovery oriented and trauma-informed care, and overdose prevention, including the administration of naloxone. Vendor shall provide State with monthly data reports, including process and outcome measures. Vendor shall attend meetings and training requested by State.

3. COMPENSATION

State, upon receipt and approval of SFN 1763 Request for Reimbursement, monthly reports, and any additional information requested, shall pay Vendor no more than \$45,000 for an outreach vehicle, including special additions, such as radios and estimated arrive time, with a purchase date no later than September 30, 2017, and \$2,000 monthly for program implementation. Total payment under this

Agreement may not exceed \$95,000. Vendor shall submit its request for reimbursement to State monthly. Vendor shall submit its final payment request to State no later than 10 days after the expiration or termination of this Agreement.

4. TERMINATION

a. Termination by Mutual Agreement or Notice

This Agreement may be terminated at any time by mutual consent of both parties executed in writing, or upon 30-days' written notice by either party, with or without cause.

b. Early Termination in the Public Interest

State is entering into this Agreement for the purpose of carrying out the public policy of the state of North Dakota, as determined by its Governor, Legislative Assembly, and Courts. If this Agreement ceases to further the public policy of the state of North Dakota, State, in its sole discretion, by written notice to Vendor, may terminate this Agreement in whole or in part.

c. Termination for Lack of Funding or Authority

State may terminate the whole or any part of this Agreement, effective upon delivery of written notice to Vendor or on any later date stated in the notice, under any of the following conditions:

- 1) If funding from federal, state, or other sources is not obtained and continued at levels sufficient to allow for purchase of the services or supplies in the indicated quantities or term.
- 2) If federal or state laws or rules are modified or interpreted in a way that the services are no longer allowable or appropriate for purchase under this Agreement or are no longer eligible for the funding proposed for payments authorized by this Agreement.
- 3) If any license, permit, or certificate required by law or rule, or by the terms of this Agreement, is for any reason denied, revoked, suspended, or not renewed.

Termination of this Agreement under this subsection is without prejudice to any obligations or liabilities of either party already accrued prior to termination.

d. Termination for Cause

State may terminate this Agreement effective upon delivery of written notice to Vendor, or any later date stated in the notice:

- 1) If Vendor fails to provide services required by this Agreement within the time specified or any extension agreed to by State; or

- 2) If Vendor fails to perform any of the other provisions of this Agreement, or so fails to pursue the work as to endanger performance of this Agreement in accordance with its terms.

The rights and remedies of State provided in this section are not exclusive and are in addition to any other rights and remedies provided by law or under this Agreement.

5. NONPERFORMANCE

Failure by Vendor to perform the terms of this Agreement constitutes a breach of contract and will result in the termination of the Agreement. If a breach by Vendor renders the Agreement impossible of performance by Vendor and is caused by circumstances beyond the control of Vendor, and through no fault of Vendor, the Agreement will be terminated and State may set off, against any liability or obligations owed to Vendor under this Agreement or otherwise, any amounts paid for individual items of work which are incomplete at the time of the breach.

6. FORCE MAJEURE

Vendor shall not be held responsible for delay or default caused by fire, flood, riot, acts of God, or war if the event is beyond Vendor's reasonable control, and Vendor gives notice to State immediately upon occurrence of the event that caused, or is reasonably expected to cause, the delay or default.

7. VENDOR'S UNDERSTANDING OF TERM OF FUNDING

Vendor understands that this Agreement is a one-time agreement, and acknowledges that it has received no assurances that this Agreement may be extended beyond its expiration date.

8. VENDOR ASSURANCES

This Agreement will be construed according to the laws of the state of North Dakota. In connection with furnishing supplies or performing work under this Agreement, persons who contract with or receive funds to provide services to State are obligated and agree to comply with all local, state, and federal laws, regulations, and executive orders related to the performance of this Agreement, including the following: Fair Labor Standards Act, Equal Pay Act of 1963, Titles VI and VII of the Civil Rights Act of 1964, the Age Discrimination in Employment Act of 1967, the North Dakota Human Rights Act, the Comprehensive Alcohol Abuse and Alcoholism Prevention, Treatment, and Rehabilitation Act of 1970, the Drug Abuse Prevention, Treatment, and Rehabilitation Act of 1970, Section 504 of the Rehabilitation Act of 1973, the Age Discrimination Act of 1975, the Drug-Free Workplace Act of 1988, the Americans with Disabilities Act of 1990, Alcohol, Drug Abuse, and Mental Health Administration Reorganization Act of 1992, and the Pro-Children Act of 1994.

By signing this Agreement Vendor certifies that neither Vendor, Subcontractor, nor their principals are presently debarred, declared ineligible, or voluntarily excluded from participation in transactions with the state or federal government by any department or agency of the state or federal government.

Vendor must be an approved vendor with the Office of Management and Budget within the state of North Dakota as required by North Dakota Century Code § 54-44.4-09.

9. AUTHORITY TO CONTRACT

Vendor may subcontract with qualified vendors of services, provided that any subcontract acknowledges the binding nature of this Agreement, and incorporates this Agreement, together with its attachments, as appropriate. Vendor is solely responsible for the performance of any subcontractor. Vendor may not contract for or on behalf of or incur obligations on behalf of State. Vendor may not assign or otherwise transfer or delegate any right or duty without State's express written consent.

10. INDEPENDENT ENTITY

Vendor is an independent entity under this Agreement. Vendor, its employees, agents, or representatives are not employees of State for any purpose, including the application of the Social Security Act, the Fair Labor Standards Act, the Federal Insurance Contribution Act, the Federal Unemployment Act, the North Dakota Unemployment Compensation Law, and the North Dakota Workforce Safety and Insurance Act. No part of this Agreement may be construed to represent the creation of an employer/employee relationship between State and Vendor. Vendor retains sole and absolute discretion in the manner and means of carrying out Vendor's activities and responsibilities under this Agreement, except to the extent specified in this Agreement.

11. INDEMNITY

State and Vendor each agree to assume their own liability for any and all claims of any nature, including all costs, expenses, and attorneys' fees which may in any manner result from or arise out of this Agreement.

12. INSURANCE

Vendor shall secure and keep in force during the term of this Agreement, from insurance companies, government self-insurance pools, or government self-retention funds, authorized to do business in North Dakota, the following insurance coverages:

- 1) Commercial general liability, including premises or operations, contractual, and products or completed operations coverages (if applicable), with minimum liability limits of \$250,000 per person and \$500,000 per occurrence.
- 2) Automobile liability, including Owned (if any), Hired, and Non-Owned automobiles, with minimum liability limits of \$250,000 per person and \$500,000 per occurrence.

- 3) Workers compensation coverage meeting all statutory requirements.

The insurance coverages listed above must meet the following additional requirements:

- 1) Any deductible or self-insured retention amount or other similar obligation under the policies shall be the sole responsibility of the Vendor. The amount of any deductible or self-retention is subject to approval by the State.
- 2) This insurance may be in policy or policies of insurance, primary and excess, including the so-called umbrella or catastrophe form and must be placed with insurers rated "A-" or better by A.M. Best Company, Inc., provided any excess policy follows form for coverage. Less than an "A-" rating must be approved by the State. The policies shall be in form and terms approved by the State.
- 3) The insurance required in this Agreement, through a policy or endorsement, shall include a provision that the policy and endorsements may not be canceled or modified without 30 days' prior written notice to the undersigned State representative.
- 4) Vendor shall furnish a certificate of insurance to the undersigned State representative prior to commencement of this Agreement.
- 5) Failure to provide insurance as required in this Agreement is a material breach of contract entitling State to terminate this Agreement immediately.

13. NOTICE

Any notice or other communication required under this Agreement must be given by registered or certified mail and is complete on the date mailed when addressed to the parties at the following addresses:

City of Fargo
1240 25th Street South
Fargo, ND 58103

OR

ND Department of Human Services
Behavioral Health Division
1237 W. Divide Ave, Suite 1D
Bismarck, ND 58501

Notice provided under this provision does not meet the notice requirements for monetary claims against State found at North Dakota Century Code § 32-12.2-04.

14. INTEGRATION, MODIFICATION, AND CONFLICT IN DOCUMENTS

This Agreement constitutes the entire Agreement between Vendor and State. There are no understandings, agreements, or representations, oral or written, not specified within this Agreement. No alteration, amendment, or modification of this Agreement is effective unless it is reduced to writing, signed by the parties, and attached to the Agreement.

If any inconsistency exists between this Agreement and other provisions of collateral contractual agreements which are made a part of this Agreement by reference or otherwise, the provisions of this Agreement control.

15. SEVERABILITY

If any term of this Agreement is declared by a court having jurisdiction to be illegal or unenforceable, the validity of the remaining terms will not be affected and, if possible, the rights and obligations of the parties are to be construed and enforced as if the Agreement does not contain the illegal or unenforceable term.

16. APPLICABLE LAW AND VENUE

This Agreement is governed by and construed according to the laws of the state of North Dakota. Any action to enforce this Agreement must be adjudicated exclusively in the state District Court of Burleigh County, North Dakota. Each party consents to the exclusive jurisdiction of such court and waives any claim of lack of jurisdiction or *forum non conveniens*.

17. ASSIGNMENT

Neither party may assign this Agreement or the party's rights under this Agreement without the written approval of the other party. Approval to assign may not be unreasonably withheld. This Agreement is equally binding on the respective parties and their successors and assigns.

18. SPOILIATION – PRESERVATION OF EVIDENCE

Vendor shall promptly notify State of all potential claims that arise or result from this Agreement. Vendor shall also take all reasonable steps to preserve all physical evidence and information that may be relevant to the circumstances surrounding a potential claim, while maintaining public safety, and grants to State the opportunity to review and inspect the evidence, including the scene of an accident.

19. WORKS FOR HIRE

Vendor acknowledges that all work(s) under this Agreement is "work(s) for hire" within the meaning of the United States Copyright Act (Title 17 United States Code) and hereby assigns to State all rights and interests Vendor may have in the work(s) it prepares under this Agreement, including any right to derivative use of the work(s). All software and related materials developed by Vendor in performance of this Agreement for State shall be the sole property of State, and Vendor hereby assigns and transfers all its right, title, and interest therein to State. Vendor shall execute all necessary documents to enable State to protect State's intellectual property rights under this section.

20. WORK PRODUCT, EQUIPMENT, AND MATERIALS

All work product, equipment, and materials created for State or purchased by State under this Agreement belong to State and must be delivered to State at State's request upon expiration or termination of this Agreement.

21. CONFIDENTIAL INFORMATION

Vendor shall not use or disclose any information it receives from State under this Agreement that State has previously identified as confidential or exempt from mandatory public disclosure except as necessary to carry out the purposes of this Agreement or as authorized in advance by State. State shall not disclose any information it receives from Vendor that Vendor has previously identified as confidential and that State determines, in its sole discretion, is protected from mandatory public disclosure under a specific exception to the North Dakota open records law found in North Dakota Century Code chapter 44-04. The duty of State and Vendor to maintain confidentiality of information under this section continues beyond the term of this Agreement, including any extensions or renewals.

22. COMPLIANCE WITH PUBLIC RECORDS LAWS

Vendor understands that, except for disclosures prohibited in this Agreement, State must disclose to the public upon request any records it receives from Vendor. Vendor further understands that any records obtained or generated by Vendor under this Agreement, except for records that are confidential under this Agreement, may be open to the public upon request under certain circumstances under the North Dakota open records law. Vendor agrees to contact State immediately upon receiving a request for information under the open records law and to comply with State's instructions on how to respond to the request.

23. ATTORNEY FEES

If a lawsuit is filed by State to obtain performance due under this Agreement, and State is the prevailing party, Vendor shall pay State's reasonable attorney fees and costs in connection with the lawsuit, except when prohibited by North Dakota Century Code § 28-26-04.

24. ALTERNATIVE DISPUTE RESOLUTION – JURY TRIAL

State does not agree to any form of binding arbitration, mediation, or other forms of mandatory alternative dispute resolution. The parties may enforce their rights and remedies in judicial proceedings. State does not waive any right to a jury trial.

25. NONDISCRIMINATION AND COMPLIANCE WITH LAWS

Vendor shall comply with all laws, rules, and policies, including those relating to nondiscrimination, accessibility, and civil rights. Vendor shall timely file all required reports, make required payroll deductions, and timely pay all taxes and premiums owed, including sales and use taxes, unemployment compensation, and workers' compensation premiums. Vendor also shall have and keep current at all times during the term of this Agreement all licenses and permits required by law.

26. ACCESS TO BOOKS AND RECORDS

Vendor shall provide State, the federal government, and their duly authorized representatives access to the books, documents, papers, and records of Vendor, which are pertinent to the services provided under this Agreement, for the purpose of making an audit or examination, or for making excerpts and transcripts. All records, regardless of physical form, and the accounting practices and procedures of Vendor relevant to this Agreement are subject to examination by the North Dakota State Auditor, the Auditor's designee, or federal auditors. Vendor shall maintain all of these records for at least three years following completion of this Agreement and be able to provide them at any reasonable time. State, State Auditor, or Auditor's designee shall provide reasonable notice.

CITY OF FARGO

By Ruth Roman

Ruth Roman
By Director of Public Health

Date October 19, 2017

By _____ DATE

Timothy J. Mahoney
Its Mayor, City of Fargo

45-6002069
Vendor's Federal Taxpayer Identification Number

STATE OF NORTH DAKOTA

NORTH DAKOTA DEPARTMENT OF HUMAN SERVICES

By _____ DATE
PAMELA SAGNESS, DIRECTOR
BEHAVIORAL HEALTH DIVISION

By _____ DATE
AMY JANGULA JOHNSON
CONTRACT OFFICER
Approved for form and content

(10)

MEMORANDUM

TO: Board of City Commissioners

FROM: Steven Sprague, City Auditor
Ben Dow, Director of Operations

SUBJECT: Downtown Recycling Removal Agreement

DATE: October 6, 2017

The public works department has hired a contractor to remove recycling materials from the recycle receptacles in the downtown since the beginning of the Business Improvement District (BID). In an effort to enhance the service delivery and to provide for coordinated efforts in recycling removal, we are recommending contracting with the Downtown Community Partnership (DCP) for recycling removal services in the downtown. The agreed upon fee will be the same amount paid to the previous contractor, the term is for one year.

Recommended Motion:

Approve the Recycle Removal Service Agreement between the City of Fargo and the Downtown Community Partnership.

SERVICES AGREEMENT

RECYCLING REMOVAL SERVICE for CITY-OWNED RECEPTACLES

THIS CONTRACT SERVICES AGREEMENT (herein "Agreement"), is made and entered into this ____ day of _____, 2017, by and between the City of Fargo, North Dakota, a municipal corporation, (herein "City"), and the Downtown Community Partnership, a North Dakota nonprofit corporation, whose address is 210 Broadway N. Unit #202, Fargo, North Dakota, 58102, (herein "DCP"). The parties hereto agree as follows:

1.0 SERVICES OF CONTRACTOR

1.1 Scope of Services.

In compliance with all terms and conditions of this Agreement, the DCP shall provide Recycling Removal Service for City-Owned receptacles located within the Downtown Business District. DCP will be required to empty each receptacle weekly. Included in the duties is to empty the receptacles, delivery of recyclables to MinnKota Recycling Processing Facility (430 7th Street N.) and placement of a new plastic liner (which will be provided by DCP) in the receptacle. As a material inducement to City entering into this Agreement, DCP represents and warrants that DCP is a provider of first class work and services and DCP is experienced in performing the work and services contemplated herein and, in light of such status and experience, DCP covenants that it shall follow the highest professional standards in performing the work and services required hereunder and that all materials will be of good quality, fit for the purpose intended. For purposes of this Agreement, the phrase "highest professional standards" shall mean those standards of practice recognized by one or more first-class firms performing similar work under similar circumstances.

1.2 Compliance with Law.

All services rendered hereunder shall be provided in accordance with all ordinances, resolutions, statutes, rules, and regulations of City and any Federal, State or local governmental agency having jurisdiction in effect at the time service is rendered.

1.3 Familiarity with Work.

By executing this Contract, DCP warrants that representatives (a) have thoroughly investigated and considered the scope of services to be performed, (b) have carefully considered how the services should be performed, and (c) fully understands the difficulties and restrictions attending performance of the services under this Agreement. Should the DCP discover any latent or unknown conditions, which will materially affect the performance of the services hereunder, DCP shall immediately inform City of such fact and shall not proceed except at DCP's risk until written instructions are received from City.

1.4 Care of Work.

DCP shall adopt reasonable methods during the life of the Agreement to furnish continuous protection to the work, and the equipment, materials and/or other components thereof

to prevent losses or damages, and shall be responsible for all such damages, to persons or property, until acceptance of the work by City, except such losses or damages as may be caused by City's own negligence.

1.5 Damage to Cities' Property.

The DCP will ensure that all equipment utilized during the duration of the agreement will not damage recycling receptacles. In the event that such damage occurs, DCP shall promptly reimburse the City for the cost to repair such damages.

1.6 Further Responsibilities of Parties.

Both parties agree to use reasonable care and diligence to perform their respective obligations under this Agreement. Both parties agree to act in good faith to execute all instruments, prepare all documents and take all actions as may be reasonably necessary to carry out the purposes of this Agreement. Unless hereafter specified, neither party shall be responsible for the service of the other.

2.0 COMPENSATION

2.1 Contract Sum.

For the services rendered pursuant to this Agreement, the DCP shall be compensated \$ 432.00 , per can per year.

2.2 Method of Payment.

DCP shall submit to City in the form approved by City, an invoice for services rendered no later than the first (1st) working day of each month City shall pay DCP for all expenses stated thereon which are approved by City pursuant to this Agreement no later than the last working day of the month.

3.0 PERFORMANCE SCHEDULE

3.1 Schedule of Performance.

DCP shall commence the services pursuant to this Agreement upon receipt of a written notice to proceed and shall perform all services within the time period(s) established by the Contract Officer.

3.2 Term.

Agreement shall continue in full force and effect until completion of the services but not exceeding one (1) year from the date hereof.

4.0 COORDINATION OF WORK

4.1 Representative of DCP.

The following principals of DCP are hereby designated as being the principals and representatives authorized to act in its behalf with respect to the work specified herein and make all decisions in connection therewith:

Jonathan Holth.

4.2 Subletting of Contract.

This DCP shall not sublet except with the written consent of the City. No such consent shall be construed as making the City a party to such subcontract, or subjecting the City to liability of any kind to any subcontractor. No subcontract shall, under any circumstances, relieve the DCP of his or her liability and obligation under his or her contract, and all transactions with the City must be through the DCP.

4.3 Assignability/Transfer of Interests.

There shall be no assignment/transfer of interests or delegation of DCP's rights, duties or responsibilities without the prior written approval of the City.

5.0 MISCELLANEOUS PROVISIONS

5.1 Disclaimer of Liability.

The Cities of Fargo will not hold harmless or indemnify DCP for any liability whatsoever.

5.2 Hold Harmless.

The City will be held harmless and free from any and all liability, claims, or expenses whatsoever incurred by, or on behalf of, any person or organization.

5.3 Termination Prior to Expiration of Term.

This Section shall govern any termination of this Agreement except as specifically provided in the following Section for termination for cause. City reserves the right to terminate this Agreement at any time, with or without cause, upon seventy-two (72) hours' written notice to DCP. In addition, DCP reserves the right to terminate this Agreement at any time, with or without cause, upon sixty (60) days' written notice to City, except that where termination is due to the fault of City, the period of notice may be such shorter time as DCP may determine. Upon receipt of any notice of termination, DCP shall immediately cease all services hereunder except such as may be specifically approved by City. Except where DCP has initiated termination, DCP shall be entitled to compensation for all services rendered prior to the effective date of the notice of termination and for any services authorized by the City. In the event DCP has initiated termination, DCP shall be entitled to compensation only for the reasonable value of the work product actually produced hereunder. In the event of termination without cause pursuant to this Section, the terminating party need not provide the non-terminating party with the opportunity to cure.

DATED the day and year first above written.

OWNER:

THE CITY OF FARGO, NORTH DAKOTA
a municipal corporation

By _____
Dr. Tim Mahoney, Mayor

ATTEST:

Steven Sprague, City Auditor

DCP:

Downtown Community Partnership:

By:  _____ Jonathan Holth
Its: President / CEO



MEMORANDUM

TO: Board of City Commissioners

FROM: Steven Sprague, City Auditor
Ben Dow, Director of Operations

SUBJECT: Downtown Trash Removal Agreement

DATE: October 6, 2017

The public works department has hired a contractor to remove trash from the trash receptacles in the downtown since the beginning of the Business Improvement District (BID). In an effort to enhance the service delivery and to provide for coordinated efforts in trash removal, we are recommending contracting with the Downtown Community Partnership (DCP) for trash removal services in the downtown. The agreed upon fee will be the same amount paid to the previous contractor, the term is for one year.

Recommended Motion:

Approve the Trash Removal Service Agreement between the City of Fargo and the Downtown Community Partnership.

SERVICES AGREEMENT

TRASH REMOVAL SERVICE for CITY-OWNED RECEPTACLES

THIS CONTRACT SERVICES AGREEMENT (herein "Agreement"), is made and entered into this ____ day of _____, 2017, by and between the City of Fargo, North Dakota, a municipal corporation, (herein "City"), and the Downtown Community Partnership, a North Dakota nonprofit corporation, whose address is 210 Broadway N. Unit #202, Fargo, North Dakota, 58102, (herein "DCP"). The parties hereto agree as follows:

1.0 SERVICES OF CONTRACTOR

1.1 Scope of Services.

In compliance with all terms and conditions of this Agreement, the DCP shall provide Trash Removal Service for City-Owned receptacles located within the Downtown Business District. DCP will be required to empty each receptacle three times per week. Included in the duties is to empty the receptacles, trash disposal and placement of a new plastic liner (which will be provided by DCP) in the receptacle and disposal of the trash. As a material inducement to City entering into this Agreement, DCP represents and warrants that DCP is a provider of first class work and services and DCP is experienced in performing the work and services contemplated herein and, in light of such status and experience, DCP covenants that it shall follow the highest professional standards in performing the work and services required hereunder and that all materials will be of good quality, fit for the purpose intended. For purposes of this Agreement, the phrase "highest professional standards" shall mean those standards of practice recognized by one or more first-class firms performing similar work under similar circumstances.

1.2 Compliance with Law.

All services rendered hereunder shall be provided in accordance with all ordinances, resolutions, statutes, rules, and regulations of City and any Federal, State or local governmental agency having jurisdiction in effect at the time service is rendered.

1.3 Familiarity with Work.

By executing this Contract, DCP warrants that representatives (a) have thoroughly investigated and considered the scope of services to be performed, (b) have carefully considered how the services should be performed, and (c) fully understands the difficulties and restrictions attending performance of the services under this Agreement. Should the DCP discover any latent or unknown conditions, which will materially affect the performance of the services hereunder, DCP shall immediately inform City of such fact and shall not proceed except at DCP's risk until written instructions are received from City.

1.4 Care of Work.

DCP shall adopt reasonable methods during the life of the Agreement to furnish continuous protection to the work, and the equipment, materials and/or other components thereof to prevent losses or damages, and shall be responsible for all such damages, to persons or

property, until acceptance of the work by City, except such losses or damages as may be caused by City's own negligence.

1.5 Damage to Cities' Property.

The DCP will ensure that all equipment utilized during the duration of the agreement will not damage trash receptacles. In the event that such damage occurs, DCP shall promptly reimburse the City for the cost to repair such damages.

1.6 Further Responsibilities of Parties.

Both parties agree to use reasonable care and diligence to perform their respective obligations under this Agreement. Both parties agree to act in good faith to execute all instruments, prepare all documents and take all actions as may be reasonably necessary to carry out the purposes of this Agreement. Unless hereafter specified, neither party shall be responsible for the service of the other.

2.0 COMPENSATION

2.1 Contract Sum.

For the services rendered pursuant to this Agreement, the DCP shall be compensated \$ 432.00 , per can per year.

2.2 Method of Payment.

DCP shall submit to City in the form approved by City, an invoice for services rendered no later than the first (1st) working day of each month City shall pay DCP for all expenses stated thereon which are approved by City pursuant to this Agreement no later than the last working day of the month.

3.0 PERFORMANCE SCHEDULE

3.1 Schedule of Performance.

DCP shall commence the services pursuant to this Agreement upon receipt of a written notice to proceed and shall perform all services within the time period(s) established by the Contract Officer.

3.2 Term.

Agreement shall continue in full force and effect until completion of the services but not exceeding one (1) year from the date hereof.

4.0 COORDINATION OF WORK

4.1 Representative of DCP.

The following principals of DCP are hereby designated as being the principals and representatives authorized to act in its behalf with respect to the work specified herein and make all decisions in connection therewith:

Jonathan Holth

4.2 Subletting of Contract.

This DCP shall not sublet except with the written consent of the City. No such consent shall be construed as making the City a party to such subcontract, or subjecting the City to liability of any kind to any subcontractor. No subcontract shall, under any circumstances, relieve the DCP of his or her liability and obligation under his or her contract, and all transactions with the City must be through the DCP.

4.3 Assignability/Transfer of Interests.

There shall be no assignment/transfer of interests or delegation of DCP's rights, duties or responsibilities without the prior written approval of the City.

5.0 MISCELLANEOUS PROVISIONS

5.1 Disclaimer of Liability.

The Cities of Fargo will not hold harmless or indemnify DCP for any liability whatsoever.

5.2 Hold Harmless.

The City will be held harmless and free from any and all liability, claims, or expenses whatsoever incurred by, or on behalf of, any person or organization.

5.3 Termination Prior to Expiration of Term.

This Section shall govern any termination of this Agreement except as specifically provided in the following Section for termination for cause. City reserves the right to terminate this Agreement at any time, with or without cause, upon seventy-two (72) hours' written notice to DCP. In addition, DCP reserves the right to terminate this Agreement at any time, with or without cause, upon sixty (60) days' written notice to City, except that where termination is due to the fault of City, the period of notice may be such shorter time as DCP may determine. Upon receipt of any notice of termination, DCP shall immediately cease all services hereunder except such as may be specifically approved by City. Except where DCP has initiated termination, DCP shall be entitled to compensation for all services rendered prior to the effective date of the notice of termination and for any services authorized by the City. In the event DCP has initiated termination, DCP shall be entitled to compensation only for the reasonable value of the work product actually produced hereunder. In the event of termination without cause pursuant to this Section, the terminating party need not provide the non-terminating party with the opportunity to cure.

DATED the day and year first above written.

OWNER:

THE CITY OF FARGO, NORTH DAKOTA
a municipal corporation

By _____
Dr. Tim Mahoney, Mayor

ATTEST:

Steven Sprague, City Auditor

DCP:

Downtown Community Partnership:

By:  _____ Jonathan Horth

Its: President / CEO

(12)

MEMORANDUM

TO: Board of City Commissioners

FROM: Steven Sprague, City Auditor
Ben Dow, Director of Operations

SUBJECT: Snow and Ice Management of Pedestrian Rail Crossings Agreement

DATE: October 6, 2017

The public works department has hired a contractor to remove snow and ice from the pedestrian rail crossings in the downtown since the beginning of the Business Improvement District (BID). In an effort to enhance the service delivery and to provide for coordinated efforts in snow and ice removal, we are recommending contracting with the Downtown Community Partnership (DCP) for snow and ice removal in pedestrian rail crossing in the downtown. The agreed upon fee will be the same amount paid to the previous contractor, the term is for one year.

Recommended Motion:

Approve the Snow and Ice Management of Pedestrian Rail Crossings Agreement between the City of Fargo and the Downtown Community Partnership.

SERVICES AGREEMENT

Snow and Ice Management of Railroad Pedestrian Crossings

THIS CONTRACT SERVICES AGREEMENT (herein "Agreement"), is made and entered into this ____ day of _____, 2017, by and between the City of Fargo, North Dakota, a municipal corporation, (herein "City"), and the Downtown Community Partnership, a North Dakota nonprofit corporation, whose address is 210 Broadway N. Unit #202, Fargo, North Dakota, 58102, (herein "DCP"). The parties hereto agree as follows:

1.0 SERVICES OF CONTRACTOR

1.1 Scope of Services.

In compliance with all terms and conditions of this Agreement, the DCP shall provide Snow and Ice Management of the Railroad Pedestrian Crossings located with downtown. It will be up to the DCP's discretion to perform the services as weather conditions warrant and transportation conditions permit.

Snow and Ice Management Services

Location of Crossings

A complete list of locations has been included (Exhibit A). The DCP is encouraged to familiarize themselves with all locations.

Removal of Snowfall

DCP will remove all snowfall accumulation from assigned crossings. DCP will use whatever method it determines, in its sole and absolute discretion, to be the most appropriate method to clear any snow accumulation. DCP will be required to clear the crossing of snow and ice to the full width of the sidewalk so as to maintain a passable sidewalk.

Icy Conditions

DCP shall treat icy conditions using appropriate and industry standard chemical applications as necessary.

Timeframe

DCP will be required to complete snow removal of crossings as to comply with **CITY ORDINANCE 18-0301**.

Safety

All snow and ice management services will be conducted in a safe manner, with care given to the safety of the general public. This includes having all equipment outfitted with the proper lighting devices so as to be visible while operating.

As a material inducement to City entering into this Agreement, DCP represents and warrants that DCP is a provider of first class work and services and DCP is experienced in performing the work and services contemplated herein and, in light of such status and experience, DCP covenants that it shall follow the highest professional standards in performing the work and

services required hereunder and that all materials will be of good quality, fit for the purpose intended. For purposes of this Agreement, the phrase "highest professional standards" shall mean those standards of practice recognized by one or more first-class firms performing similar work under similar circumstances.

1.2 Compliance with Law.

All services rendered hereunder shall be provided in accordance with all ordinances, resolutions, statutes, rules, and regulations of City and any Federal, State or local governmental agency having jurisdiction in effect at the time service is rendered.

1.3 Familiarity with Work.

By executing this Contract, DCP warrants that representatives (a) have thoroughly investigated and considered the scope of services to be performed, (b) have carefully considered how the services should be performed, and (c) fully understands the difficulties and restrictions attending performance of the services under this Agreement. Should the DCP discover any latent or unknown conditions, which will materially affect the performance of the services hereunder, DCP shall immediately inform City of such fact and shall not proceed except at DCP's risk until written instructions are received from City.

1.4 Care of Work.

DCP shall adopt reasonable methods during the life of the Agreement to furnish continuous protection to the work, and the equipment, materials and/or other components thereof to prevent losses or damages, and shall be responsible for all such damages, to persons or property, until acceptance of the work by City, except such losses or damages as may be caused by City's own negligence.

1.5 Damage to Cities' Property.

The DCP will ensure that all equipment utilized during the duration of the agreement will not cause damage. In the event that such damage occurs, DCP shall promptly reimburse the City for the cost to repair such damages.

1.6 Further Responsibilities of Parties.

Both parties agree to use reasonable care and diligence to perform their respective obligations under this Agreement. Both parties agree to act in good faith to execute all instruments, prepare all documents and take all actions as may be reasonably necessary to carry out the purposes of this Agreement. Unless hereafter specified, neither party shall be responsible for the service of the other.

2.0 COMPENSATION

2.1 Contract Sum.

For the services rendered pursuant to this Agreement, the DCP shall be compensated \$ 480.00 , per snow event.

2.2 Method of Payment.

DCP shall submit to City in the form approved by City, an invoice for services rendered no later than the first (1st) working day of each month City shall pay DCP for all expenses stated thereon which are approved by City pursuant to this Agreement no later than the last working day of the month.

3.0 PERFORMANCE SCHEDULE

3.1 Schedule of Performance.

DCP shall commence the services pursuant to this Agreement upon receipt of a written notice to proceed and shall perform all services within the time period(s) established by the Contract Officer.

3.2 Term.

Agreement shall continue in full force and effect until completion of the services but not exceeding one (1) year from the date hereof.

4.0 COORDINATION OF WORK

4.1 Representative of DCP.

The following principals of DCP are hereby designated as being the principals and representatives authorized to act in its behalf with respect to the work specified herein and make all decisions in connection therewith:

Jonathan Halth

4.2 Subletting of Contract.

This DCP shall not sublet except with the written consent of the City. No such consent shall be construed as making the City a party to such subcontract, or subjecting the City to liability of any kind to any subcontractor. No subcontract shall, under any circumstances, relieve the DCP of his or her liability and obligation under his or her contract, and all transactions with the City must be through the DCP.

4.3 Assignability/Transfer of Interests.

There shall be no assignment/transfer of interests or delegation of DCP's rights, duties or responsibilities without the prior written approval of the City.

5.0 MISCELLANEOUS PROVISIONS

5.1 Disclaimer of Liability.

The Cities of Fargo will not hold harmless or indemnify DCP for any liability whatsoever.

5.2 Hold Harmless.

The City will be held harmless and free from any and all liability, claims, or expenses whatsoever incurred by, or on behalf of, any person or organization.

5.3 Termination Prior to Expiration of Term.

This Section shall govern any termination of this Agreement except as specifically provided in the following Section for termination for cause. City reserves the right to terminate this Agreement at any time, with or without cause, upon seventy-two (72) hours' written notice to DCP. In addition, DCP reserves the right to terminate this Agreement at any time, with or without cause, upon sixty (60) days' written notice to City, except that where termination is due to the fault of City, the period of notice may be such shorter time as DCP may determine. Upon receipt of any notice of termination, DCP shall immediately cease all services hereunder except such as may be specifically approved by City. Except where DCP has initiated termination, DCP shall be entitled to compensation for all services rendered prior to the effective date of the notice of termination and for any services authorized by the City. In the event DCP has initiated termination, DCP shall be entitled to compensation only for the reasonable value of the work product actually produced hereunder. In the event of termination without cause pursuant to this Section, the terminating party need not provide the non-terminating party with the opportunity to cure.

DATED the day and year first above written.

OWNER:

THE CITY OF FARGO, NORTH DAKOTA
a municipal corporation

By _____
Dr. Tim Mahoney, Mayor

ATTEST:

Steven Sprague, City Auditor

DCP:

Downtown Community Partnership:

By:  - Jonathan Holt

Its: President / CEO

EXHIBIT A

Downtown Railroad Crossings	
500 Block of Broadway N	
500 Block of Roberts St. N	
500 Block of 4th St. N	
4 8th St. N	
2 Broadway N	
10 4th St. N	

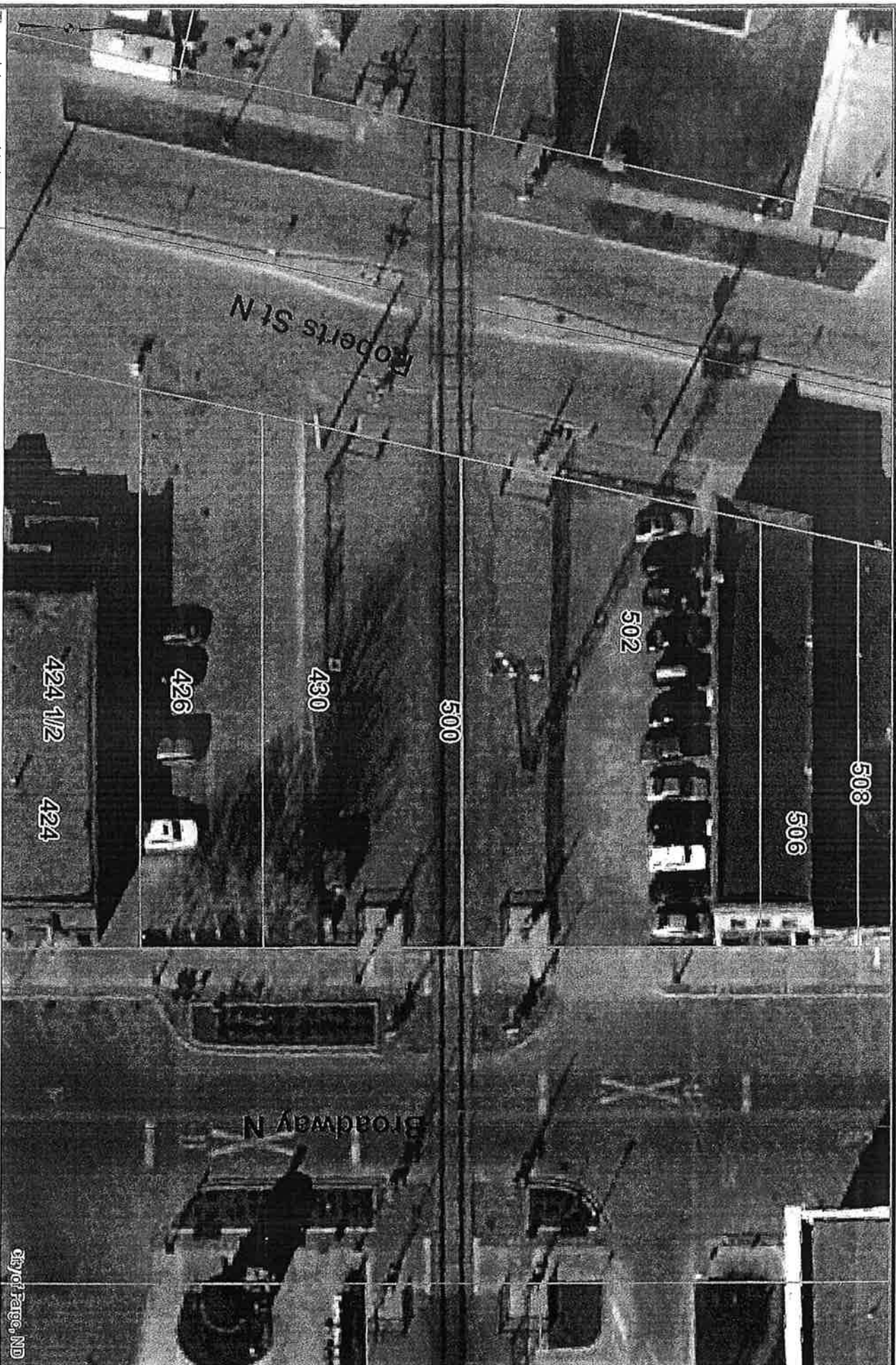

City of Fargo, ND

500 Block of Broadway N and Roberts St N

These data are provided on an "AS-IS" basis, without warranty of any type, expressed or implied, including but not limited to any warranty of merchantability, or fitness for any particular purpose.

1:564

8/25/2016 4:04:15 PM



This map is not a substitute for accurate field surveys or for creating actual property lines and any adjacent features.

510

508

506

A

420

4th St N

City of Fargo, ND

These data are provided on an "AS-IS" basis, without warranty of any type, expressed or implied, including but not limited to any warranty as to their performance, merchantability, or fitness for any particular purpose.

500 Block of 4th St N

1:564

8/25/2016 4:05:20 PM

This map is not a substitute for accurate field surveys or for locating actual property lines and any adjacent features.



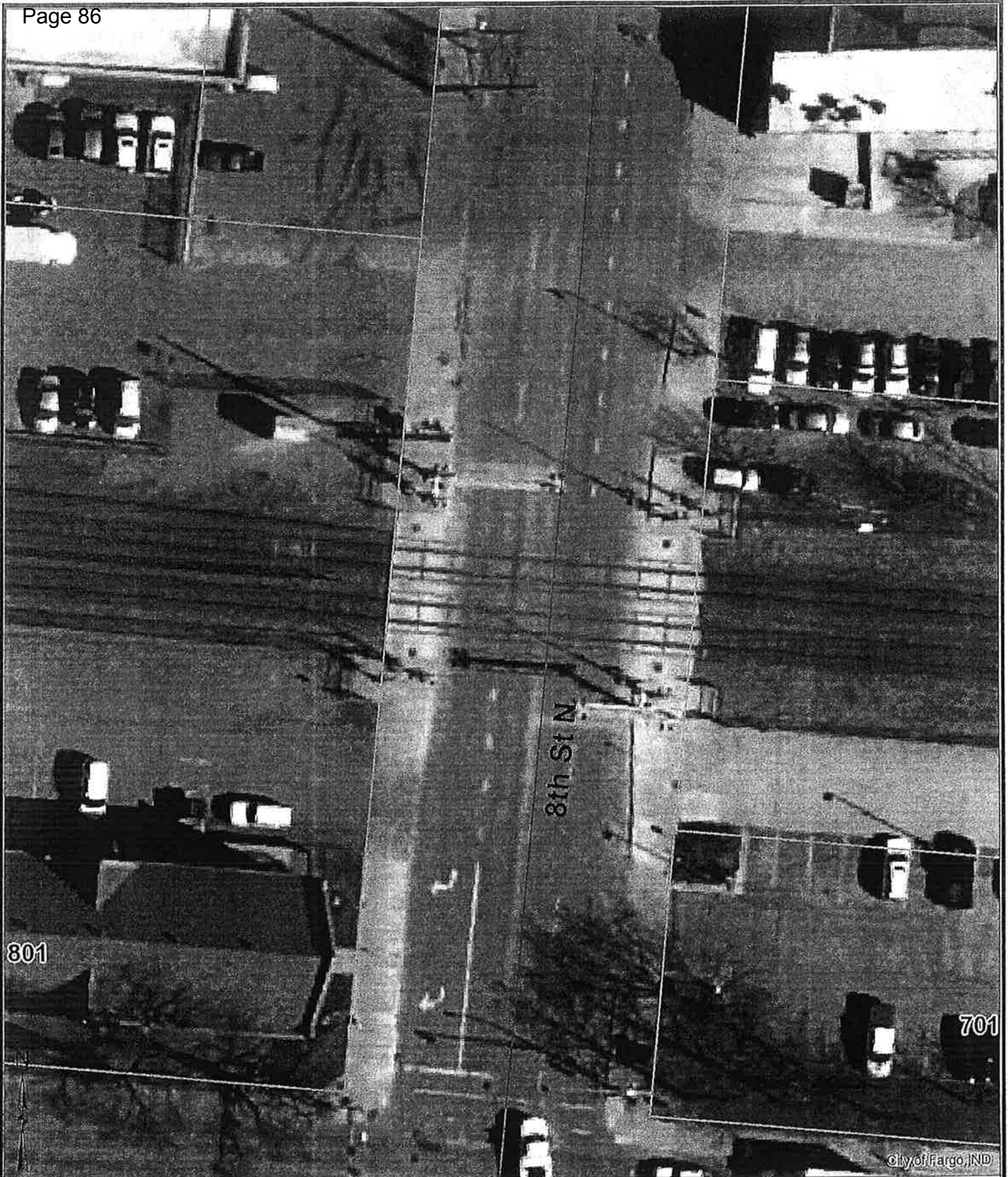

City of Fargo, ND

These data are provided on an "AS-IS" basis, without warranty of any type, expressed or implied, including but not limited to any warranty as to their performance, merchantability, or fitness for any particular purpose.

4 8th St N

1:564

8/25/2016 4:06:06 PM

This map is not a substitute for accurate field surveys or for locating actual property lines and any adjacent features.



BROADWAY N

201

302

202

303

203

304

204

305

205

306

206

10

6

City of Fargo, ND

These data are provided on an "AS-IS" basis, without warranty of any type, expressed or implied, including but not limited to any warranty as to their performance, merchantability, or fitness for any particular purpose.

2 Broadway N

1:564

8/25/2016 4:06:39 PM

This map is not a substitute for accurate field surveys or for locating actual property lines and any adjacent features.



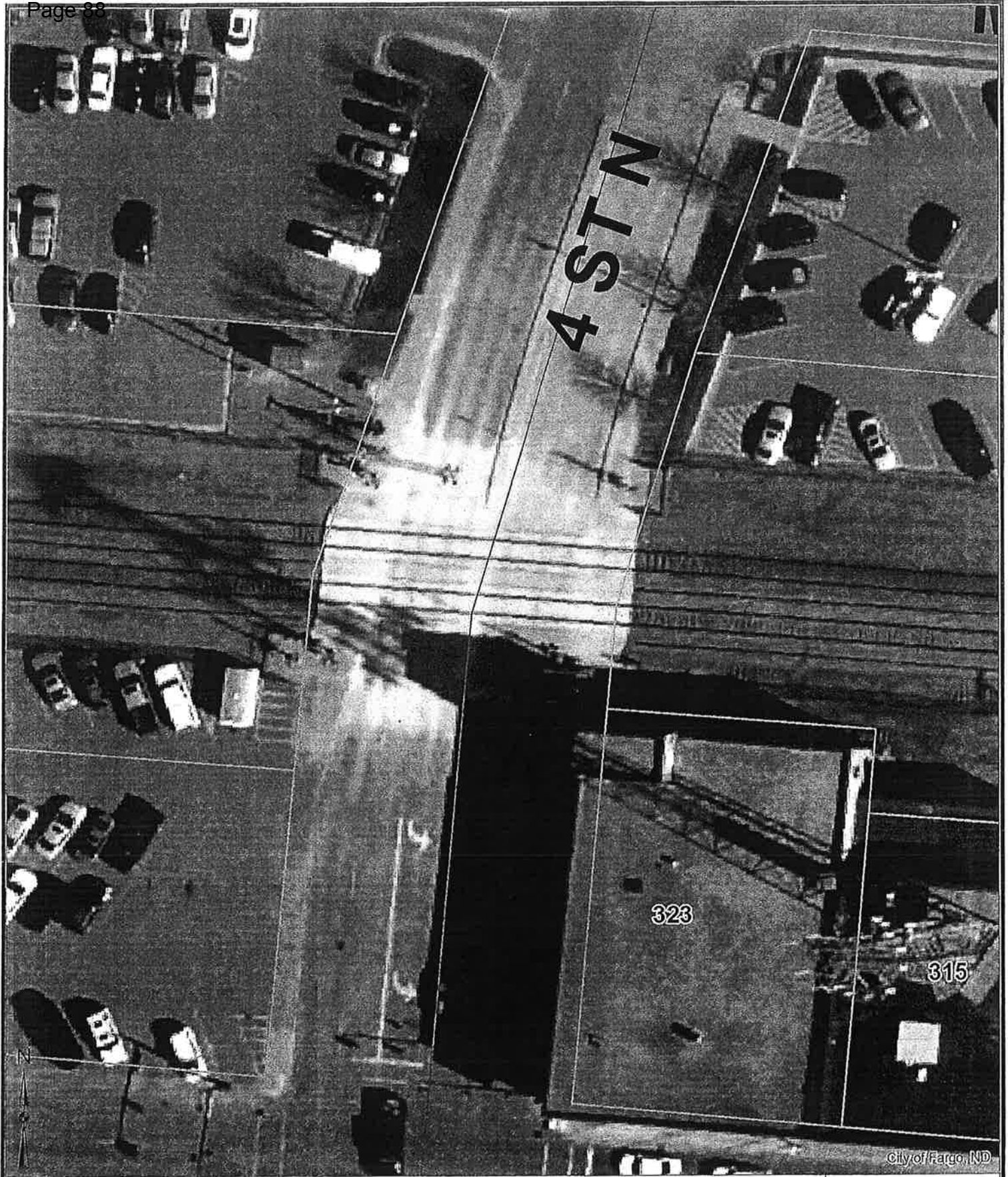

City of Fargo, ND

These data are provided on an "AS-IS" basis, without warranty of any type, expressed or implied, including but not limited to any warranty as to their performance, merchantability, or fitness for any particular purpose.

10 4th St N

1:564

8/25/2016 4:07:12 PM

This map is not a substitute for accurate field surveys or for locating actual property lines and any adjacent features.





OFFICE OF THE CITY ADMINISTRATOR
Bruce P. Grubb

October 19, 2017

MEMORANDUM

13a-c

To: Board of City Commissioners
From: Bruce P. Grubb, City Administrator *BPG*
Re: City Hall Construction – General Contract Change Order #13
Mechanical Contract Change Order #6
Electrical Contract Change Order #9

Attached, please find copies of Change Orders associated with the General, Mechanical and Electrical Contracts for the City Hall construction project. A description of the change orders and associated dollar amounts is shown below:

General Contract

Change Order #13 **\$240.00**

- Plywood backing behind gypsum board sheathing in IS Department.

Mechanical Contract

Change Order #6 **\$4,930.00**

- Revise air ductwork routing and RA opening locations in IS data center room.

Electrical Contract

Change Order #9 **\$2,174.00**

- First floor office revisions for Inspections Department.

With approval of the above referenced change order, an updated summary of the construction contracts would be as follows:

PROJECT SUMMARY					
Contract	Contractor	Original Bid	Change Orders	Current Amount	% Change
General	Olaf Anderson	\$16,442,900	\$710,816	\$17,153,716	4.32%
Mechanical	Robert Gibb	\$3,447,000	\$84,096	\$3,531,096	2.44%
Electrical	Sun Electric	\$2,607,000	\$50,021	\$2,657,021	1.92%
Total		\$22,496,900	\$844,933	\$23,341,833	3.76%

Similarly, a summary of the overall project budget would be as follows:

BUDGET SUMMARY			
Budget Category	Original Total	Current Total	Paid To-Date
City Hall Construction	\$22,000,000	\$23,341,833	\$14,003,447
FF&E	\$1,775,000	\$1,775,000	\$0
Centennial Hall Demo	\$600,000	\$772,468	\$772,468
Professional Fees	\$1,400,000	\$1,580,956	\$1,580,956
Contingency	\$1,940,767	\$245,510	NA
Total	\$27,715,767	\$27,715,767	\$16,856,871

Your consideration in this matter is greatly appreciated.

Suggested Motion:

Approve the following change order associated with the City Hall construction project:

Olaf Anderson	Change Order #13 in the amount of \$240.00
Robert Gibb	Change Order #6 in the amount of \$4,930.00
Sun Electric	Change Order #9 in the amount of \$2,174.00

C: Mike Redlinger, Assistant City Administrator
 Kent Costin, Finance Director
 Erik Johnson, City Attorney
 Terry Stroh, TL Stroh Architects

City Hall Construction Report - Contractor Progress Payments (10/19/17)

Contract	Contractor	Bid Amount	Change Orders	Present Amount	Paid To-date	Balance
General	Olaf Anderson	\$ 16,442,900	\$ 710,816	\$ 17,153,716	\$ 10,830,026	\$ 6,323,690
Mechanical	Robert Gibb	\$ 3,447,000	\$ 84,096	\$ 3,531,096	\$ 2,428,374	\$ 1,102,722
Electrical	Sun Electric	\$ 2,607,000	\$ 50,021	\$ 2,657,021	\$ 745,047	\$ 1,911,974
Total		\$ 22,496,900	\$ 844,933	\$ 23,341,833	\$ 14,003,447	\$ 9,338,386

PROJECT BUDGET SUMMARY

Budget Category	Original Total	Current Total	Paid To-Date
City Hall Construction	\$ 22,000,000	\$ 23,341,833	\$ 14,003,447
FF&E	\$ 1,775,000	\$ 1,775,000	\$ -
Centennial Hall Demo	\$ 600,000	\$ 772,468	\$ 772,468
Professional Fees	\$ 1,400,000	\$ 1,580,956	\$ 1,580,956
Contingency	\$ 1,940,767	\$ 245,510	\$ -
Total Budget	\$ 27,715,767	\$ 27,715,767	\$ 16,356,871

CHANGE ORDER SUMMARY

General Contract		\$	710,816
#1	Addition of curtain wall windows.	\$	396,565
#2	Revisions to generator building to accommodate mechanical changes.	\$	3,260
#3	Removal of existing foundation that was not known prior to construction. Lower footings to accommodate underground piping. Connection of City Hall & Civic Center roof and sump drainage system to new storm sewer.	\$	26,160
#4	Provide additional point load to three joists per structural engineer.	\$	46,014
#5	Design revisions to third floor.	\$	18,918

#6	Commission chamber revisions to remove windows and replace with Pre-Fin metal wall panels for televising clarity and security.	\$	45,463
#7	Add a new downstream storm sewer defender manhole, water main extension and hydrant, reroute storm sewer to avoid transformer/conduits. Existing 12" and 15" pipes deeper than proposed storm sewer. To connect Civic Center roof drains, the first 5 manholes coming off 66" storm sewer on 3rd Ave. need to be extended. Also extend downstream defender manhole.	\$	61,866
#8	Labor and materials associated with revisions to the interior floor plans. Construct a fire pump room block wall enclosure & door. IS request to install 3/4" CDX plywood backing behind gypsum board. Changes associated with Inspections Department request to add exterior pedestrian ramps to side entrance.	\$	26,049
#9	Geofoam foundation system.	\$	13,774
#10	Floor plan revisions to Commission offices.	\$	20,801
#11	Plywood backing behind gypsum board sheathing in IS Department.	\$	5,000
#12		\$	240
#13		\$	84,096
Mechanical Contract			
#1	Addition of sump pits and domestic water service.	\$	13,222
#2	Pricing reduction for control dampers.	\$	(4,100)
#3	Design revisions to third floor and HVAC modifications.	\$	36,016
#4	Omit finned tube radiation, add CO/NO2 monitors and VFD	\$	20,956
#5	Revised ductwork routing and sizing associated with floor plan revisions. Revise boiler venting to achieve 4' separation per State inspector. Revise location of fire protection riser, fire pump, jockey pump, dry system valve and air compressor in the added fire pump room.	\$	13,072
#6	Revise air ductwork routing and RA opening locations in IS data center room.	\$	4,930
Electrical Contract			
#1	Relocate emergency generator for City Hall and Civic temporary power.	\$	12,960
#2	Design revisions to third floor.	\$	2,797
#3	Revise voltage of UPS to 480V in lieu of 208V.	\$	(3,341)
#4	Connect exhaust fan EF-8 to 20A/3P circuit breaker at HEM11 in lieu of 15A/3P circuit breaker at switchboard. Connect generator room damper motors to panel LEM11 in lieu of panel LG1.	\$	1,396
#5	IS requested revisions to training room.	\$	29,075

#6	Floor plan revisions for lighting and lighting control.	\$	1,857
#7	Electrical work associated with the added fire pump room.	\$	1,359
#8	Floor plan revisions to Commission offices.	\$	1,744
#9	Rough-ins for future panic buttons in reception areas.	\$	2,174
	First floor office revisions for Inspections Department.	\$	

AIA® Document G701™ – 2001

Change Order

PROJECT (Name and address): Fargo City Hall Fargo, ND	CHANGE ORDER NUMBER: Gen#013 DATE: 9/13/17	OWNER: <input checked="" type="checkbox"/> ARCHITECT: <input checked="" type="checkbox"/> CONTRACTOR: <input checked="" type="checkbox"/> FIELD: <input type="checkbox"/> OTHER: <input type="checkbox"/>
TO CONTRACTOR (Name and address): Olaf Anderson Construction PO Box 2766 Fargo, ND 58108	ARCHITECT'S PROJECT NUMBER: 2015.49 CONTRACT DATE: 6/7/16 CONTRACT FOR: General Construction	

THE CONTRACT IS CHANGED AS FOLLOWS:

(Include, where applicable, any undisputed amount attributable to previously executed Construction Change Directives)
 PRG9: Inspections Office plan modifications and Room W127 modifications.
 DEDUCT (\$1,258.00)

PRG12: Provide 3/4" CDX plywood backing behind gypsum board sheathing over entire west and south walls within Office E304.
 ADD \$1,498.00

The original Contract Sum was	\$ 16,442,900.00
The net change by previously authorized Change Orders	\$ 710,576.25
The Contract Sum prior to this Change Order was	\$ 17,153,476.25
The Contract Sum will be increased by this Change Order in the amount of	\$ 240.00
The new Contract Sum including this Change Order will be	\$ 17,153,716.25

The Contract Time will be increased by Zero (0) days.
 The date of Substantial Completion as of the date of this Change Order therefore is

NOTE: This Change Order does not include changes in the Contract Sum, Contract Time or Guaranteed Maximum Price which have been authorized by Construction Change Directive until the cost and time have been agreed upon by both the Owner and Contractor, in which case a Change Order is executed to supersede the Construction Change ~~Directive~~ Directive.

NOT VALID UNTIL SIGNED BY THE ARCHITECT, CONTRACTOR AND OWNER.

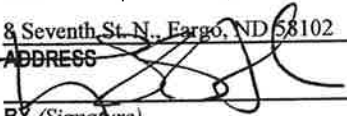
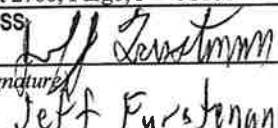
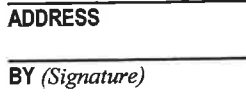
T.L. Stroh Architects, Ltd ARCHITECT (Firm name)	Olaf Anderson Construction CONTRACTOR (Firm name)	City of Fargo OWNER (Firm name)
& Seventh St. N., Fargo, ND 58102 ADDRESS	PO Box 2766, Fargo, ND 58108 ADDRESS	200 3rd St. N., Fargo, ND 58102 ADDRESS
 BY (Signature)	 BY (Signature)	 BY (Signature)
Terry L. Stroh (Typed name)	Jeff Furstenan (Typed name)	Jeff Furstenan (Typed name)
9/13/17 DATE	9-13-17 DATE	DATE



CHANGE PROPOSAL NO: PR-G9

Date sent to Contractor:

7-10-17

PROPOSAL REQUEST (NOT A CHANGE ORDER)

PROJECT: Fargo City Hall
Fargo, North Dakota

To: Olaf Anderson Construction
P.O. Box 2766
Fargo, ND 58108-2766

Attn: Lyn Narum

The cost of the following changes in your contract on the above job is hereby requested, and this form shall be completed and returned to our office as soon as possible. A breakdown of your costs shall be attached. Make three (3) copies. Keep one return two to T. L. Stroh Architects. Wait until notification before doing this work.

DESCRIPTION OF THE PROPOSED CHANGES

Provide labor and materials cost to make revisions to the interior floor plans as indicated on the attached drawings.

1. Inspections Office plan modifications.
2. Room W127 modifications.

All work shall be equal to contract specifications.

This will ADD \$ _____ to the contract price.

OR

This will DEDUCT \$ (1,258.00) from the contract price.

Sign for Contractor:

By: _____

Date: 9/5/17



8 Seventh St. N.
Fargo, ND 58102
Phone (701) 231-1100
Fax (701) 231-1000
stroharchitect.com

Handwritten signature
PROJECT NO. 15-001

NEW FARGO CITY HALL
CITY OF FARGO
Fargo, North Dakota
Location:
FARGO, ND 58102

Drawn By:
TJ SCHMIDT
Date:
MARCH 2ND, 2017
Revision Date:
FEB. 29D, 2017
MAR. 13TH, 2017
APR. 10TH, 2017
Job Number:
2015.49

Sheet Name:
FIRST FLOOR PLAN -
AREA 'A'

Sheet Number:
A2.3

- NOTE:**
SEE OTHER SHEETS FOR LOCATION OF WALL PARTS.
ALL DIMENSIONS ARE TO FACE UNLESS OTHERWISE NOTED.
ALL DIMENSIONS ARE TO FACE UNLESS OTHERWISE NOTED.
ALL DIMENSIONS ARE TO FACE UNLESS OTHERWISE NOTED.
- GENERAL PLAN NOTES:**
1. ALL DIMENSIONS ARE TO FACE UNLESS OTHERWISE NOTED.
 2. ALL DIMENSIONS ARE TO FACE UNLESS OTHERWISE NOTED.
 3. ALL DIMENSIONS ARE TO FACE UNLESS OTHERWISE NOTED.
 4. ALL DIMENSIONS ARE TO FACE UNLESS OTHERWISE NOTED.
 5. ALL DIMENSIONS ARE TO FACE UNLESS OTHERWISE NOTED.
- SHEET A2.3 - PARTIAL FIRST FLOOR**
- GENERAL PLAN NOTES:**
1. ALL DIMENSIONS ARE TO FACE UNLESS OTHERWISE NOTED.
 2. ALL DIMENSIONS ARE TO FACE UNLESS OTHERWISE NOTED.
 3. ALL DIMENSIONS ARE TO FACE UNLESS OTHERWISE NOTED.
 4. ALL DIMENSIONS ARE TO FACE UNLESS OTHERWISE NOTED.
 5. ALL DIMENSIONS ARE TO FACE UNLESS OTHERWISE NOTED.
- SHEET A2.3 - FIRST FLOOR PLAN NOTES:**
1. USE INDICATED ANCHORAGE - SEE DETAIL.
 2. USE INDICATED ANCHORAGE - SEE DETAIL.
 3. USE INDICATED ANCHORAGE - SEE DETAIL.
 4. USE INDICATED ANCHORAGE - SEE DETAIL.
 5. USE INDICATED ANCHORAGE - SEE DETAIL.
 6. USE INDICATED ANCHORAGE - SEE DETAIL.
 7. USE INDICATED ANCHORAGE - SEE DETAIL.
 8. USE INDICATED ANCHORAGE - SEE DETAIL.
 9. USE INDICATED ANCHORAGE - SEE DETAIL.
 10. USE INDICATED ANCHORAGE - SEE DETAIL.
 11. USE INDICATED ANCHORAGE - SEE DETAIL.
 12. USE INDICATED ANCHORAGE - SEE DETAIL.
 13. USE INDICATED ANCHORAGE - SEE DETAIL.
 14. USE INDICATED ANCHORAGE - SEE DETAIL.

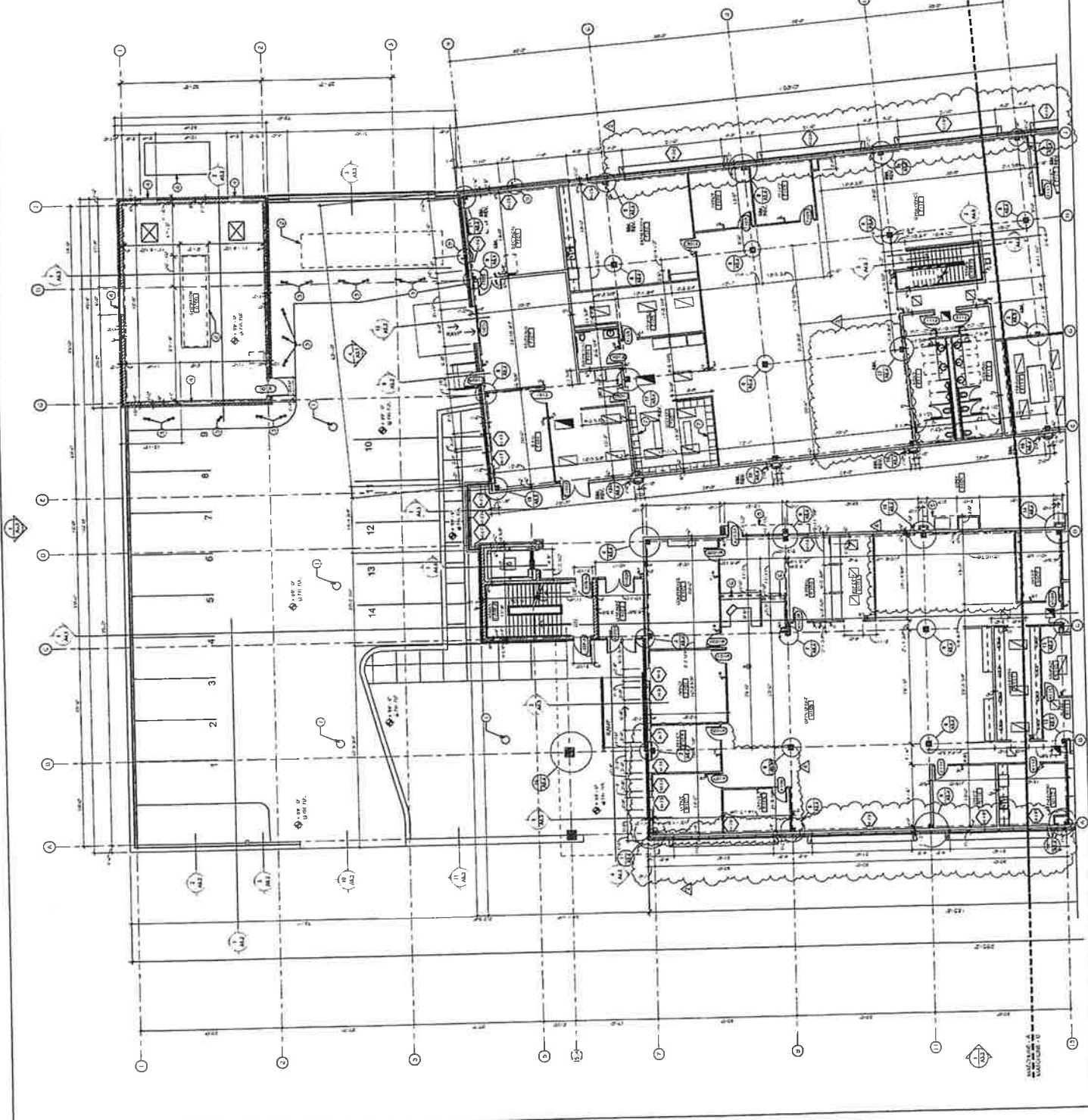

PARTIAL FIRST FLOOR PLAN - AREA 'A'



8 Seventh St. N.
Fargo, ND 58102
Phone (701) 233-4100
Fax (701) 233-4104
www.stroharchitects.com

Handwritten initials/signature

DATE: 3/2/17

NEW FARGO CITY HALL
CITY OF FARGO
Fargo, North Dakota

Location: FARGO, ND 58102

Drawn By: TUDM/UKB

Date: MARCH 2ND, 2017

Revision Date:
FEB. 2ND, 2017
MAY 17TH, 2017
JULY 17TH, 2017

Job Number: 2015.49

Sheet Name: PARTIAL FLOOR PLAN - AREA 'B'

Sheet Number: A2.4

Project:

- NOTE:**
ALL DIMENSIONS ARE FROM FACE OF THE CONCRETE MAJORIT;
ALL DIMENSIONS ARE FROM FACE OF THE CONCRETE MAJORIT;
USE COORDINATE SYSTEM FOR LOCATION OF THE SUBMITTALS;
SHEET A2.4 - PARTIAL FIRST FLOOR
- GENERAL PLAN NOTES:**
1. ALL DIMENSIONS ARE FROM FACE OF THE CONCRETE MAJORIT;
 2. ALL NEW WALKER WALLS TO BE 2' 6" HIGH WITH 3/4" REBAR AND 1/2" GROUT AT JOINTS. ALL EXISTING WALKER WALLS TO BE 2' 6" HIGH WITH 3/4" REBAR AND 1/2" GROUT AT JOINTS. ALL EXISTING WALKER WALLS TO BE 2' 6" HIGH WITH 3/4" REBAR AND 1/2" GROUT AT JOINTS.
 3. ZZZZ INDICATES CONCRETE BLOCK WALL CONSTRUCTION;
 4. ZZZZ INDICATES METAL STUD WALL CONSTRUCTION;
 5. ZZZZ INDICATES CONCRETE WALL CONSTRUCTION;
- SHEET A2.4 - FIRST FLOOR PLAN NOTES:**
1. THE INDICATED SORTIT ABOVE
 2. THE INDICATED WALL BELOW
 3. TYP. ALUMINUM INSULATED PANEL (A) (S) (S) 1-11

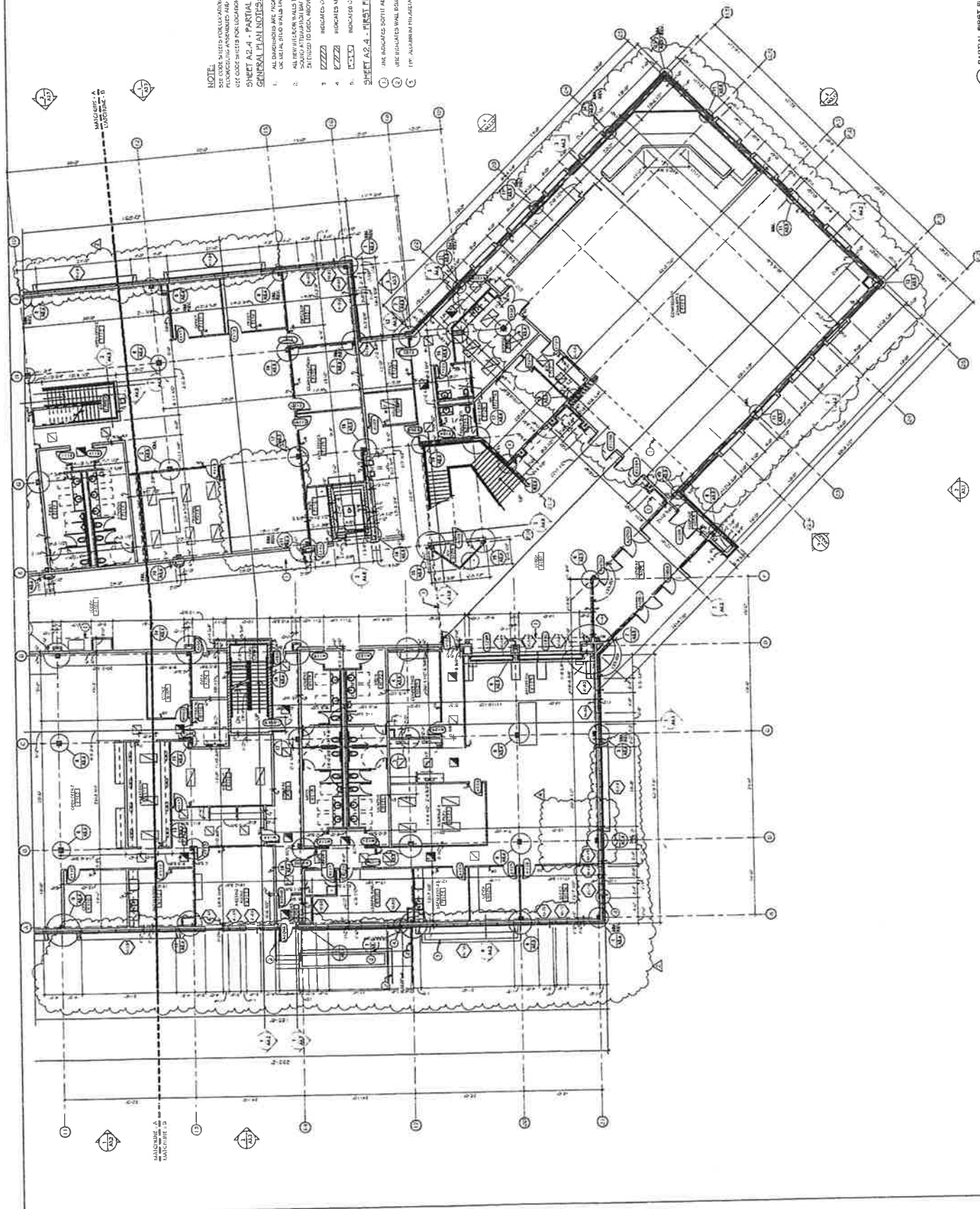

PARTIAL FIRST FLOOR PLAN - AREA 'B'

STROH
ARCHITECTS & ENGINEERS
8 Seventh St. N.
Fargo, ND 58102
Phone: (701) 234-4100
www.stroh.com

DATE: 02/28/16 FILE: A6.4A
PROJECT: NEW FARGO CITY HALL

Project:

NEW FARGO CITY HALL
CITY OF FARGO
Fargo, North Dakota

Location:
FARGO, ND 58102

Drawn By:
Author

Date:
MARCH 2ND, 2017

Revision Date:
FEB 20, 2017

Job Number:
2015_49

Sheet Name:
WINDOW FRAME
ELEVATIONS

Sheet Number:
A6.4A

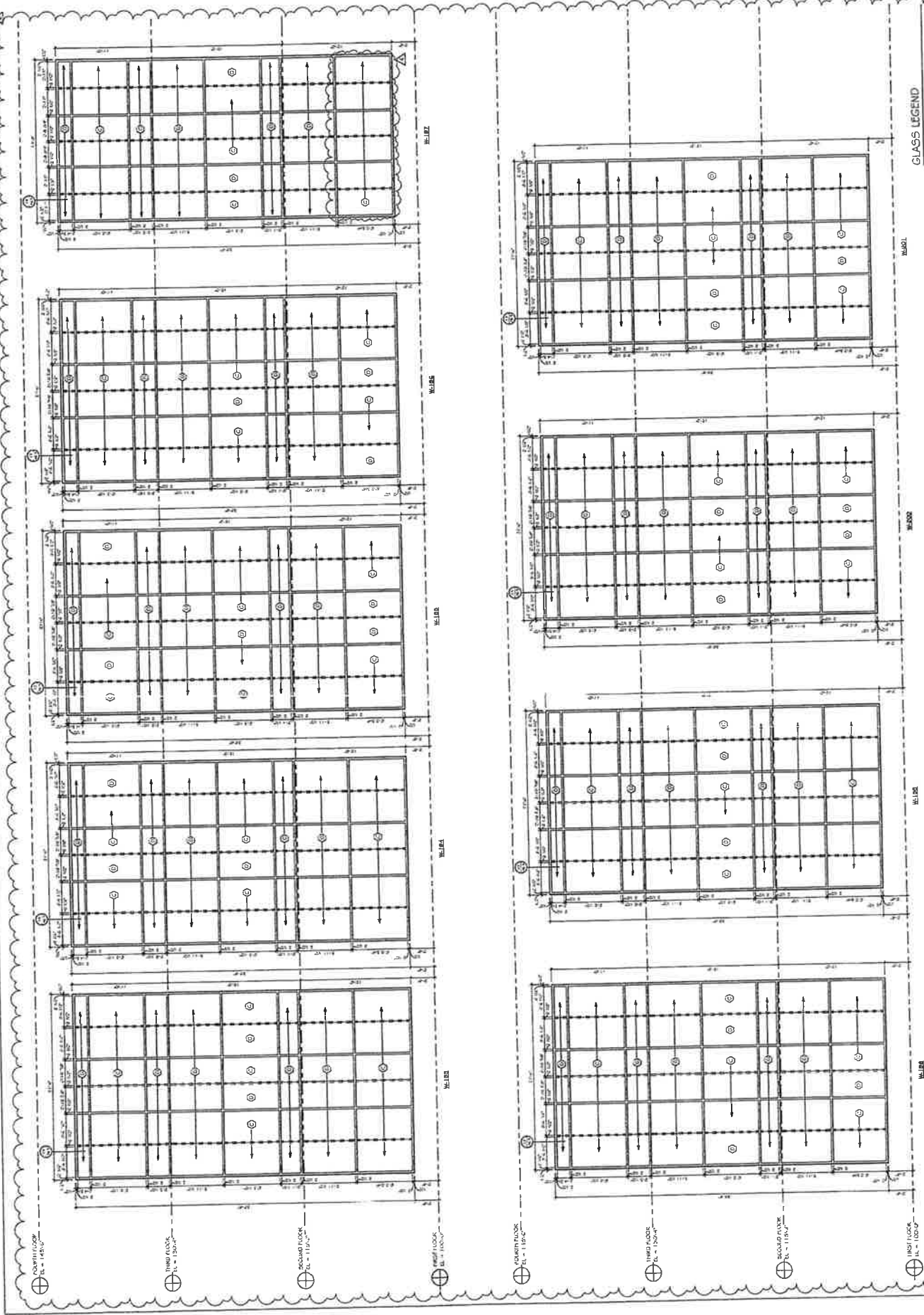

CLASS LEGEND

- 1/4" SQUARE REINFORCED SQUARE-TIE BAR (SECTION)
- 1/4" SQUARE REINFORCED SQUARE-TIE BAR (SECTION)
- 1/4" SQUARE REINFORCED SQUARE-TIE BAR (SECTION)
- 1/4" SQUARE REINFORCED SQUARE-TIE BAR (SECTION)



410-11612 | 1-800-444-4444
8 Seventh St. N.
Fargo, ND 58102
www.stroh.com

STROH ARCHITECTS
1000 13th Ave SW
Fargo, ND 58103
701-785-2200

Handwritten initials: TSB

NEW FARGO CITY HALL
CITY OF FARGO
Fargo, North Dakota

Location:
FARGO, ND 58102

Drawn By:
T.L.S./D.A.M.K.B.

Date:
MARCH 2ND, 2017

Revision Date:
FEB. 2ND, 2017
MAR. 13th, 2017
APR. 11th, 2017

Job Number:
2015.49

Sheet Name:
FIRST FLOOR ROOM
FINISH PLAN - AREA
"A"

Sheet Number:
A8.3

Project:

- NOTE:**
SEE CODE SHEETS FOR LOCATION OF WALL FINISHES.
SEE CODE SHEETS FOR LOCATION OF FINE LATHWORK.
SEE CODE SHEETS FOR LOCATION OF FINE LATHWORK.
SEE CODE SHEETS FOR LOCATION OF FINE LATHWORK.
- GENERAL FINISH PLAN NOTES:**
1. ALL CONCRETE ARE FROM FACE OF REINFORCED CONCRETE. MAJOR FINISHES ON METAL AND BRASS FINISHES OTHERWISE NOTED.
 2. ALL NEW INTERIOR WALLS TO BE 5" RIG METALS SLUGS WITH JOINTS ATTACHED WITH INSULATION UNLESS OTHERWISE NOTED.
 3. **ZZZZ** INDICATES CONCRETE FLOOR, WALL CONSTRUCTION.
 4. **ZZZZ** INDICATES METAL STUD WALL CONSTRUCTION.
 5. **ZZZZ** INDICATES CONCRETE WALL CONSTRUCTION.
 6. SEE INTERIOR ELEVATIONS & BATHROOM SECTION FOR WALL FINISHES AND FLOOR FINISHES.
 7. SEE INTERIOR ELEVATIONS & BATHROOM SECTION FOR WALL FINISHES AND FLOOR FINISHES.
 8. SEE INTERIOR ELEVATIONS & BATHROOM SECTION FOR WALL FINISHES AND FLOOR FINISHES.
 9. SEE INTERIOR ELEVATIONS & BATHROOM SECTION FOR WALL FINISHES AND FLOOR FINISHES.
 10. PRODUCT TRANSDUCERS AT FLOOR/CEILING JOINTS, SEE FINISH SPEC. FOR DETAILS.

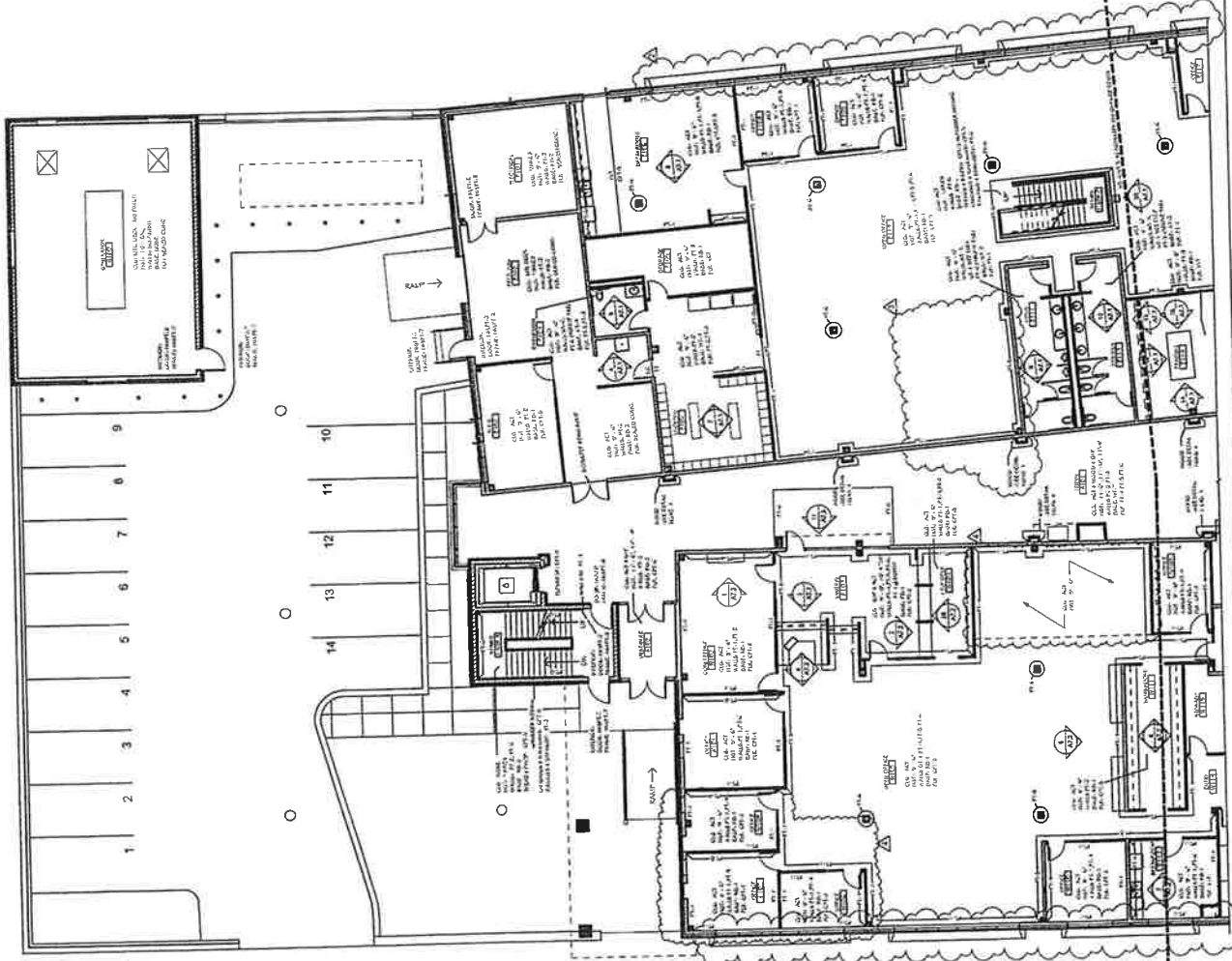

PARTIAL FIRST FLOOR ROOM FINISH PLAN - AREA "A"

SCALE: 1/8" = 1'-0"

STROH
ARCHITECTURAL INTERIORS
8 Seventh St. N.
Fargo, ND 58102
Phone: (701) 246-1188
Fax: (701) 246-1189
www.stroh.com

PROJECT NO. 15-001
DATE: 03/20/17
DRAWN BY: T.S.D./M.K.B.
CHECKED BY: T.S.D./M.K.B.
DATE: 03/20/17

T.S.D.

Location:
FARGO, ND 58102
CITY OF FARGO
FARGO, North Dakota

Drawn By:
T.S.D./M.K.B.

Date:
MARCH 2ND, 2017

Revision Date:
FEB. 2ND, 2017
MAY 13TH, 2017
MAY 31TH, 2017

Job Number:
2015.49

Sheet Name:
FIRST FLOOR ROOM
FINISH PLAN - AREA

Sheet Number:
A8.4

Project:

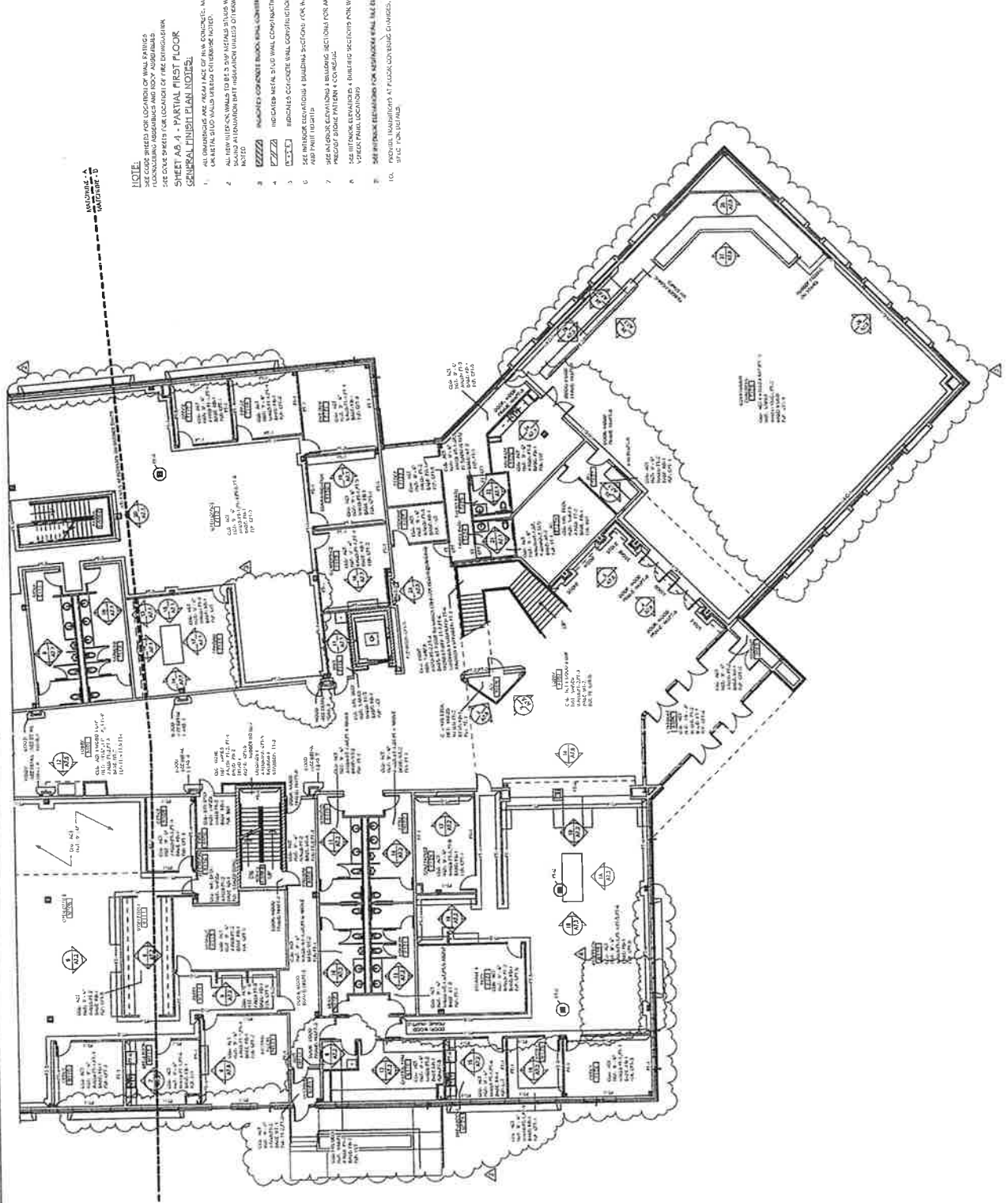

- NOTE:**
SEE CASE SCHEDULE FOR LOCATIONS OF WALL FINISHES
INCLUDING REVISIONS AND ROOM IDENTIFIERS
SEE CASE SCHEDULE FOR LOCATIONS OF WALL FINISHES
INCLUDING REVISIONS AND ROOM IDENTIFIERS
- SHEET A8.4 - PARTIAL FIRST FLOOR
GENERAL FINISH PLAN - AREA**
1. ALL DIMENSIONS ARE UNLESS OTHERWISE NOTED.
 2. FINISHES ARE TO BE APPLIED TO ALL SURFACES UNLESS OTHERWISE NOTED.
 3. FINISHES ARE TO BE APPLIED TO ALL SURFACES UNLESS OTHERWISE NOTED.
 4. FINISHES ARE TO BE APPLIED TO ALL SURFACES UNLESS OTHERWISE NOTED.
 5. FINISHES ARE TO BE APPLIED TO ALL SURFACES UNLESS OTHERWISE NOTED.
 6. FINISHES ARE TO BE APPLIED TO ALL SURFACES UNLESS OTHERWISE NOTED.
 7. FINISHES ARE TO BE APPLIED TO ALL SURFACES UNLESS OTHERWISE NOTED.
 8. FINISHES ARE TO BE APPLIED TO ALL SURFACES UNLESS OTHERWISE NOTED.
 9. FINISHES ARE TO BE APPLIED TO ALL SURFACES UNLESS OTHERWISE NOTED.
 10. FINISHES ARE TO BE APPLIED TO ALL SURFACES UNLESS OTHERWISE NOTED.

PARTIAL FIRST FLOOR ROOM FINISH PLAN - AREA
Sheet Number: A8.4



SRH
SOUTHDAKOTA
REGISTERED ARCHITECTS
9 SEVENTH ST. N.
FARGO, ND 58102
PHONE (701) 238-4100
FAX (701) 238-0843
WWW.SOUTHDAKOTASRH.COM

Project:
NEW FARGO CITY HALL
FARGO, NORTH DAKOTA

Location:
FARGO, ND 58102
Drawn By:
TJSD/MKB
Date:
MARCH 2ND, 2017
Revision Date:
APR 13TH 2017
JULY 14TH 2017
Job Number:
2015.48
Sheet Name:
FIRST FLOOR RCP -
AREA 'B'

Sheet Number:
A9.4

GENERAL REFLECTED CEILING PLAN NOTES:
1. ALL DIMENSIONS TO FACE OF CONCRETE, MASONRY OR METAL STUD WALLS UNLESS OTHERWISE NOTED.

SHEET A9.4 - FIRST FLOOR RCP NOTES:

- 1. BIR - HIGHER OVERHEAD CONCR. FIN. N.
- 2. BIR - RELATES TO AREA ABLE TO HOLD 2-1/2" BIR.
- 3. LAYOUT - SEE MECH. & ELECTRICAL PLANS.

REFLECTED CEILING PLAN LEGEND

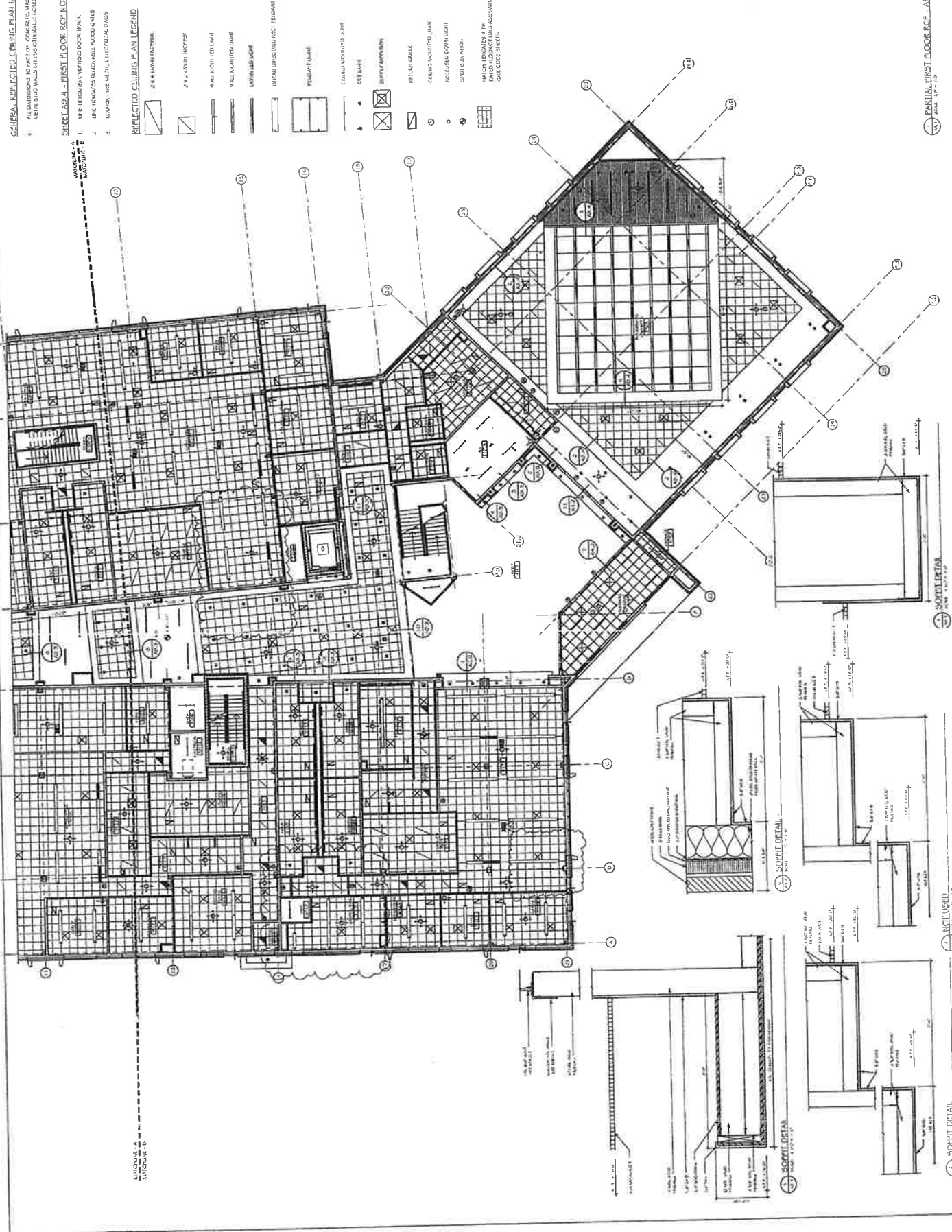
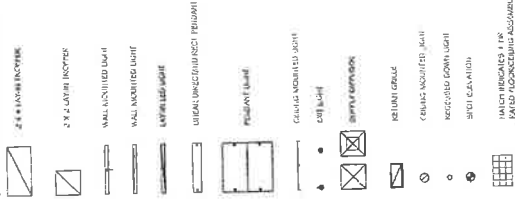

SECTION A-A
SECTION B-B

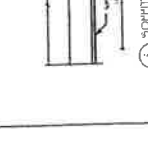
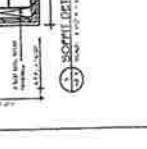
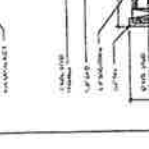
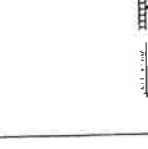

NOT USED
NOT USED



CHANGE PROPOSAL NO: PR-G12

Date sent to Contractor:

7-17-17

PROPOSAL REQUEST (NOT A CHANGE ORDER)

PROJECT: Fargo City Hall
Fargo, North Dakota

To: Olaf Anderson Construction
P.O. Box 2766
Fargo, ND 58108-2766

Attn: Lyn Narum

The cost of the following changes in your contract on the above job is hereby requested, and this form shall be completed and returned to our office as soon as possible. A breakdown of your costs shall be attached. Make three (3) copies. Keep one return two to T. L. Stroh Architects. Wait until notification before doing this work.

DESCRIPTION OF THE PROPOSED CHANGES

Provide labor and materials cost to provide 3/4" CDX plywood backing behind gypsum board sheathing over entire west and south walls within Office E304.

All work shall be equal to contract specifications.

This will ADD \$ 1,498.00 to the contract price.

~~OR This will DEDUCT \$ _____ from the contract price.~~

Sign for Contractor:

By: [Signature]

Date: 7/18/17

AIA Document G701™ – 2001

Change Order

PROJECT (Name and address): Fargo City Hall Fargo, ND	CHANGE ORDER NUMBER: Mech-006 DATE: 10/3/17	OWNER: <input checked="" type="checkbox"/> ARCHITECT: <input checked="" type="checkbox"/> CONTRACTOR: <input checked="" type="checkbox"/> FIELD: <input type="checkbox"/> OTHER: <input type="checkbox"/>
TO CONTRACTOR (Name and address): Robert Gibb & Sons 205 40th St SW Fargo, ND 58103	ARCHITECT'S PROJECT NUMBER: 2015.49 CONTRACT DATE: 6/7/16 CONTRACT FOR: Mechanical Construction	

THE CONTRACT IS CHANGED AS FOLLOWS:

(Include, where applicable, any undisputed amount attributable to previously executed Construction Change Directives)
 M13: Revise return air ductwork as shown on the attached sheet M4.7 for Data Center E308. Duct routing and RA opening locations shall be coordinated with server rack locations. ADD \$4,930.00

The original Contract Sum was	\$ 3,447,000.00
The net change by previously authorized Change Orders	\$ 79,166.00
The Contract Sum prior to this Change Order was	\$ 3,526,166.00
The Contract Sum will be increased by this Change Order in the amount of	\$ 4,930.00
The new Contract Sum including this Change Order will be	\$ 3,531,096.00

The Contract Time will be increased by Zero (0) days.
 The date of Substantial Completion as of the date of this Change Order therefore is

NOTE: This Change Order does not include changes in the Contract Sum, Contract Time or Guaranteed Maximum Price which have been authorized by Construction Change Directive until the cost and time have been agreed upon by both the Owner and Contractor, in which case a Change Order is executed to supersede the Construction Change Directive.

NOT VALID UNTIL SIGNED BY THE ARCHITECT, CONTRACTOR AND OWNER.

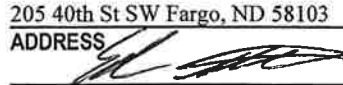
T.L. Stroh Architects, Ltd ARCHITECT (Firm name) 8 Seventh St. N., Fargo, ND 58102 ADDRESS BY  BY (Signature) Terry L. Stroh (Typed name) 10/3/17 DATE	Robert Gibb & Sons CONTRACTOR (Firm name) 205 40th St SW Fargo, ND 58103 ADDRESS BY  BY (Signature) Ed Thuedt (Typed name) 10/4/17 DATE	City of Fargo OWNER (Firm name) 200 3rd St. N., Fargo, ND 58102 ADDRESS BY _____ BY (Signature) _____ (Typed name) _____ DATE
---	---	---



PROPOSAL REQUEST – M13

Date	9/7/17
Project #	2015231
Project Name	Fargo City Hall
Project Location	Fargo, ND
Description	Data Center Ductwork

Please submit an itemized quotation for the change(s) described below to the proposed modifications to the Contract Documents. Cost proposal to include a detailed itemized breakdown indicating the specific amounts, lengths, quantities, types, sizes, etc. of material including labor, O&P, taxes, and other incidental charges to be used. Proposal shall also indicate credits, deducts, and/or offsets for material and labor originally included in contract. THIS IS NOT A CHANGE ORDER OR DIRECTION TO PROCEED WITH WORK STATED HEREIN.

State the amount to be added to the contract to revise return air ductwork as shown on the attached sheet M4.7 for Data Center E308. Duct routing and RA opening locations shall be coordinated with server rack locations.

Respectfully,
Obermiller Nelson Engineering, Inc.

Ross Young

Attachment(s): M4.7

Cc: File

F:\Projects\2015231\CA\PROPOSAL REQUEST\MECH\2015231 PR M13 - Data Room Ductwork\2015231 PR M13 - Data Room Ductwork.docx

BUILDING SYSTEMS CONSULTANTS

FARGO
2201 12th St. N Suite E
701.280.0500

GRAND FORKS
311 4th St. S Suite 203
701.775.2594

BISMARCK
233 West Rosser Ave.
701.222.0520

ALEXANDRIA
503 Hawthorne St. Suite 141
320.846.0300

MINNEAPOLIS
1400 Van Buren St. NE Suite 130
877.380.0501



Project: _____

NEW FARGO CITY HALL
CITY OF FARGO
Fargo, North Dakota

Location:
8 Seventh St. N.
Fargo, ND 58102

Drawn By:
JF/TATE

Date:
APRIL 22ND, 2016

Revision Date:
8-1-17

Job Number:
2015231

Sheet Name:
THIRD FLOOR
VENTILATION PLAN -
A

Sheet Number:
M4.7

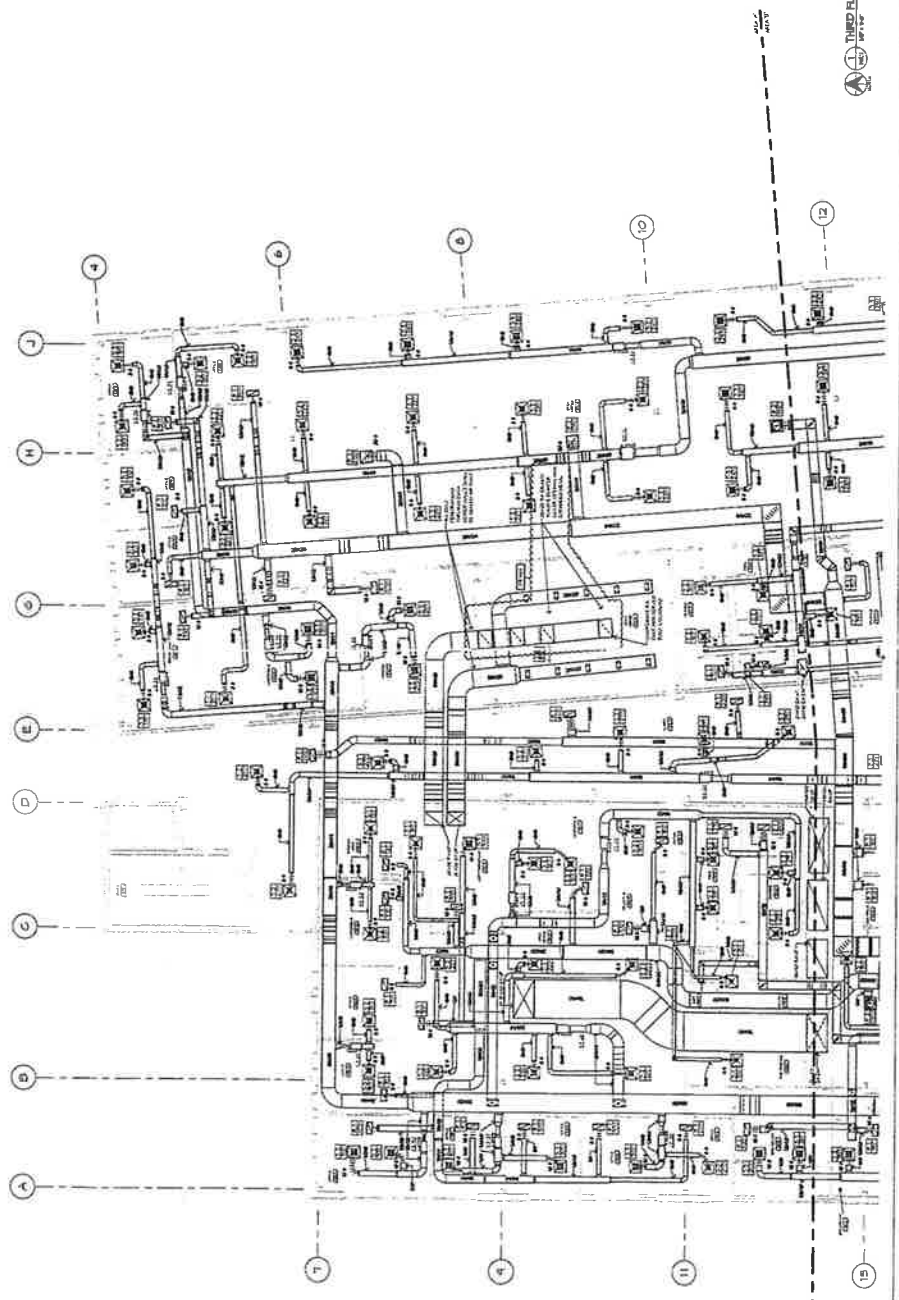

THIRD FLOOR PLAN - VENTILATION
M4.7



205 40th STREET SOUTHWEST
FARGO, NORTH DAKOTA 58103
PHONE: 701.282.5900
FAX: 701.281.0819

September 14, 2017

T.L. Stroh
Mr. Terry Stroh
8 Seventh St. N.
Fargo, ND 58102

RE: New Fargo City Hall
PR M13

Dear Mr. Stroh
Please find listed below our costs associated with PR M13.

Sheet Metal Material:		\$ 821
	Tax:	<u>\$ 62</u>
	Subtotal:	\$ 883
Sheet Metal Labor:		
53 Hours:		\$ 3,339
	Subtotal:	<u>\$ 4,222</u>
	Overhead:	\$ 422
	Profit:	\$ 232
	Bond:	<u>\$ 54</u>
	Grand Total Add:	\$ 4,930

Please contact our office with any questions or concerns at 701.282.5900.

Sincerely,
ROBERT GIBB & SONS, INC.

Ed Thvedt

JOB #522: ID 2017/09/14--1
 Page 1 of 1
 PPNAME City Hall PR-13
 EST. #01: ID 2017/09/14--1
 ESTIMATE City Hall PR-13
 PRINTED 9/14/2017 8:23:09 AM
 DATA SET #2: COMM SMACNA 12/10 copy

Combined All - Estimate File Pricing
 Robert Gibb_Son's
 205 40th. St. S.W.
 Fargo, ND 58108
 701-282-5900
 FAX: 701-281-0819
 ethvedt@robertgibb.com

MATERIAL Primary Pricing
 LABOR Primary Labor

NOTES

Category	Item				Material		Field Labor			Shop Labor		
	Size	Item Desc	Qty	UOM	Mat Unit	Mat Ext	Fld...	Fld Unit	Fld Ext	Shp ...	Shp Unit	Shp Ext
Rectangular Joints	TDC/F Cleat 6"	Four Bolt Corner...	137.00	ea	0.28	38.36	1.0...	0.0100	1.3700	1.0000	Skip	0.0000
Rectangular Joints	TDF Corners	Four Bolt Corner...	96.00	ea	0.28	26.88	1.0...	0.0050	0.4800	1.0000	0.0050	0.4800
Rectangular Joints	1/8" Butyl Gasket	Four Bolt Flange...	137.00	'	0.14	19.18	1.0...	0.0065	0.8905	1.0000	Manual	0.0000
VOLUME DAMPERS	36" x28"	RECT. VOLUME ...	1.00	ea	63.28	63.28	1.0...	Skip	0.0000	1.0000	Skip	0.0000
VOLUME DAMPERS	8-15 LIN FT PERI...	LABOR BY PERI...	1.00	ea	Skip	0.00	1.0...	1.7740	1.7740	1.0000	Skip	0.0000
HANGERS	1"	18 Ga. Strap	43.33	'	0.18	7.80	1.0...	0.0200	0.8667	1.0000	Skip	0.0000
FAB MATERIAL	22 ga	GALVANIZED	71.12	lbs	0.60	42.67	1.0...	0.0284	2.0210	1.0000	0.0104	0.7385
FAB MATERIAL	20 ga	GALVANIZED	30.01	lbs	0.60	18.00	1.0...	0.0266	0.7979	1.0000	0.0089	0.2683
FAB MATERIAL	20 ga	GALVANIZED	396.11	lbs	0.60	237.66	1.0...	0.0266	10.5319	1.0000	0.0076	3.0102
FAB MATERIAL	20 ga	GALVANIZED	299.68	lbs	0.60	179.81	1.0...	0.0430	12.8797	1.0000	0.0336	10.0632
FAB MATERIAL	20 ga	GALVANIZED	25.74	lbs	0.60	15.44	1.0...	0.0327	0.8422	1.0000	0.0315	0.8103
FAB MATERIAL	1/2"	Hardware Cloth	5.00	sq ft	1.50	7.50	1.0...	0.0200	0.1000	1.0000	0.0150	0.0750
FAB MATERIAL	2"	Air Foil Vane	251.25	'	0.47	118.09	1.0...	Skip	0.0000	1.0000	0.0100	2.5125
FAB MATERIAL	2"	Vane Rail	25.50	'	0.46	11.73	1.0...	Skip	0.0000	1.0000	0.0100	0.2550
COMPONENTS	10# x 3/4"	TEK Screws	676.00	ea	0.03	20.28	1.0...	0.0020	1.3520	1.0000	Skip	0.0000
COMPONENTS	3/8" x 1"	BOLTS-----...	96.00	ea	0.07	6.91	1.0...	0.0050	0.4800	1.0000	Skip	0.0000
COMPONENTS	3/8"	NUTS-----...	96.00	ea	0.07	6.91	1.0...	0.0050	0.4800	1.0000	Skip	0.0000
Grand Totals					820.51		34.8659			18.2129		

AIA® Document G701™ – 2001

Change Order

PROJECT <i>(Name and address):</i> Fargo City Hall Fargo, ND	CHANGE ORDER NUMBER: Elec #009 DATE: 9/13/17	OWNER: <input checked="" type="checkbox"/> ARCHITECT: <input checked="" type="checkbox"/> CONTRACTOR: <input checked="" type="checkbox"/> FIELD: <input type="checkbox"/> OTHER: <input type="checkbox"/>
TO CONTRACTOR <i>(Name and address):</i> Sun Electric Inc 411 39th St NW Fargo, ND 58102	ARCHITECT'S PROJECT NUMBER: 2015.49 CONTRACT DATE: 6/7/16 CONTRACT FOR: Electrical Construction	

THE CONTRACT IS CHANGED AS FOLLOWS:

(Include, where applicable, any undisputed amount attributable to previously executed Construction Change Directives)

PRE11: First floor office revisions.
 ADD \$2,174.00

The original Contract Sum was	\$ 2,607,000.00
The net change by previously authorized Change Orders	\$ 47,847.00
The Contract Sum prior to this Change Order was	\$ 2,654,847.00
The Contract Sum will be increased by this Change Order in the amount of	\$ 2,174.00
The new Contract Sum including this Change Order will be	\$ 2,657,021.00

The Contract Time will be increased by Zero (0) days.
 The date of Substantial Completion as of the date of this Change Order therefore is

NOTE: This Change Order does not include changes in the Contract Sum, Contract Time or Guaranteed Maximum Price which have been authorized by Construction Change Directive until the cost and time have been agreed upon by both the Owner and Contractor, in which case a Change Order is executed to supersede the Construction Change Directive.

NOT VALID UNTIL SIGNED BY THE ARCHITECT, CONTRACTOR AND OWNER.

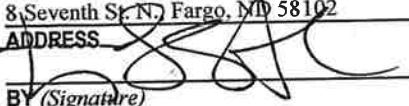
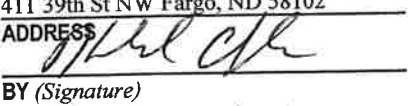
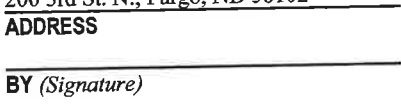
T.L. Stroh Architects, Ltd ARCHITECT <i>(Firm name)</i>	Sun Electric Inc CONTRACTOR <i>(Firm name)</i>	City of Fargo OWNER <i>(Firm name)</i>
8 Seventh St. N., Fargo, ND 58102 ADDRESS	411 39th St NW Fargo, ND 58102 ADDRESS	200 3rd St. N., Fargo, ND 58102 ADDRESS
 BY <i>(Signature)</i>	 BY <i>(Signature)</i>	 BY <i>(Signature)</i>
Terry L. Stroh <i>(Typed name)</i>	Harold Chyle <i>(Typed name)</i>	 <i>(Typed name)</i>
9/13/17 DATE	9-27-17 DATE	 DATE



Industrial - Commercial

BC

August 25, 2017

T.L. Stroh
Mr. Terry Stroh
8 Seventh St. N
Fargo, ND 58102

Re: New Fargo City Hall

Proposal Request – E11

Proposal is labor and material for electrical work associated with the First Floor Office Revisions as described in PR E11.

Proposed Price-----Add \$2,174.00

Respectfully submitted,

A handwritten signature in black ink, appearing to read "Tyler Wanzek", is written over a faint, larger signature.

Tyler Wanzek
Project Manager

Bid Summary Report

Fargo City Hall Estimator: Ryan

Job #812

Job Name: Fargo City Hall

Contractor:

Estimator: Ryan

Notes:

Bid Date: 5/26/16

Summary Description	Material			Labor		
	Extended	%	Adjusted	Extended	%	Adjusted
PR E11	\$245.88	100.00%	\$245.88	19.87	100.00%	19.87

Top Sheet

Raw Cost	\$1,716.32	Sales per Month	\$0.00
Tax	\$159.67	Return per Month	\$0.00
Raw Cost with Tax	\$1,875.98	Price per Square Foot	\$0.00
Overhead	\$171.63	Hours per Square Foot	0.00
Profit	\$94.40	Square Feet	0.00
Total Return Amount	\$266.03	Job Months	0.00
Total Return %	12.24%	Hours per Week	40.00
Price	\$2,142.01	Workers per Day	0.00
Bond	\$32.13	Total Hours	19.87
Sell Price	\$2,174.14	Mark Up Sales Tax	No
Adjusted Sell ()	\$0.00	Use Bond Table	Yes
Adjusted Sell Return 0.00 %	\$0.00		

Labor

Class Description	Percent of Total	Hours Distributed	Hourly Rate	Burden		Labor Cost
				Rate	Percent	
ND Journeyman	100.00%	19.87	\$60.00	\$0.00	0.00%	\$1,192.44
Totals	100.00%	19.87	\$60.00	\$0.00	0.00%	\$1,192.44

Mark Ups

	OVERHEAD			PROFIT		
	Total	%	Amount	%	Amount	
Materials	\$245.88	+ 10.00%	\$270.46	+ 5.00%	\$283.99	
Labor	\$1,192.44	+ 10.00%	\$1,311.68	+ 5.00%	\$1,377.27	
Supplier Quotes	\$278.00	+ 10.00%	\$305.80	+ 5.00%	\$321.09	
SubContractors	\$0.00	+ 10.00%	\$0.00	+ 5.00%	\$0.00	
Direct Job Expense	\$0.00	+ 10.00%	\$0.00	+ 5.00%	\$0.00	
Equipment Rental	\$0.00	+ 10.00%	\$0.00	+ 5.00%	\$0.00	

Bid Summary Report

Fargo City Hall Estimator: Ryan

Job #812

Totals	\$1,716.32	10.00%	\$1,887.95	5.00%	\$1,982.35
--------	------------	--------	------------	-------	------------

Tax Report

	Taxed Amount	Tax Rate %	Tax Amount
Materials	\$245.88	7.50%	\$18.44
Labor	\$1,192.44	0.00%	\$0.00
Supplier Quotes	\$278.00	7.50%	\$141.23
SubContractors	\$0.00	0.00%	\$0.00
Direct Job Expense	\$0.00	0.00%	\$0.00
Equipment Rental	\$0.00	0.00%	\$0.00
		Total Tax:	\$159.67

Supplier Quotes

Name	Supplier	Tax (7.5 %)	Unit Cost	Multiplier	Amount
Fixtures/ Controls	Graybar	Yes	\$1,883.00	1.00	\$1,883.00
Data	data tech	No	(\$1,605.00)	1.00	(\$1,605.00)
			Total:		\$278.00

Job Name: Fargo City Hall
 Job Number: 812
 Extension Name: PR E11

Item Name	Quantity	Price 2	U	Ext Price 2	NECA 1	U	Labor 1 Ext	% of Extended Price	% of Extended Hours
Label Set: Combined, Combined, Combined, Combined				\$245.88			19.87	100 %	100 %
12 THHN CU SOLID	330.00	\$160.59	M	\$53.00	6.00	M	1.98		
3/4 EMT	110.00	\$79.43	C	\$87.37	5.00	C	5.50		
1 EMT	20.00	\$137.62	C	\$27.52	5.50	C	1.10		
3/4 EMT CONN S/S	5.50	\$37.16	C	\$2.04	0.10	E	0.55		
1 EMT CONN S/S	2.00	\$78.09	C	\$1.56	0.12	E	0.24		
3/4 EMT COUP S/S	11.00	\$43.53	C	\$4.79	0.05	E	0.55		
1 EMT COUP S/S	2.00	\$65.54	C	\$1.31	0.06	E	0.12		
3/4 EMT 1 HOLE STRAP	13.75	\$25.18	C	\$3.46	4.00	C	0.55		
1 EMT 1 HOLE STRAP	2.00	\$42.95	C	\$0.86	4.00	C	0.08		
1 BUSH PLASTIC	2.00	\$26.11	C	\$0.52	0.15	E	0.30		
1/2 FLEX STEEL	18.00	\$59.65	C	\$10.74	4.00	C	0.72		
1/2 FLEX CONN	6.00	\$137.01	C	\$8.22	12.00	C	0.72		
1/2 FLEX 90 CONN	6.00	\$305.29	C	\$18.32	14.40	C	0.86		
1G IV PLAS DUPL RECP PLATE	1.00	\$40.18	C	\$0.40	10.00	C	0.10		
DPLX 5-20R COMMERCIAL	1.00	\$589.29	C	\$5.89	25.00	C	0.25		
4/S BOX 2-1/8" DP PLAIN	6.00	\$231.20	C	\$13.87	30.00	C	1.80		
4/S SG MUD RING 5/8"DP	6.00	\$99.91	C	\$5.99	15.00	C	0.90		
AH4 Fixtures	2.00	\$0.00	X	\$0.00	0.90	E	1.80		
AH8 FIXTURES	-2.00	\$0.00	Q	\$0.00	1.15	E	-2.30		
AH12 FIXTURES	-1.00	\$0.00	Q	\$0.00	2.80	E	-2.80		
AS8-3 FIXTURES	-4.00	\$0.00	Q	\$0.00	0.90	E	-3.60		
AS8 FIXTURES	6.00	\$0.00	Q	\$0.00	1.65	E	9.90		
AS12 FIXTURES	-1.00	\$0.00	Q	\$0.00	1.80	E	-1.80		
AS12-3 FIXTURES	1.00	\$0.00	Q	\$0.00	1.20	E	1.20		
ASE12 FIXTURES	1.00	\$0.00	Q	\$0.00	1.15	E	1.15		
Occ. sensor DTC	2.00	\$0.00	Q	\$0.00	0.40	E	0.80		
OS SWITCH	-1.00	\$0.00	Q	\$0.00	0.40	E	-0.40		
SWITCH D	-1.00	\$0.00	Q	\$0.00	0.40	E	-0.40		
				\$245.88			19.87		

QUOTATION
GRAYBAR ELECTRIC

PO BOX 2944
FARGO, ND 58108
PH# 701-237-0107; 1-800-753-0107
FAX # 701-237-9261

TO: SUN ELECTRIC
ATT'N TYLER

JOB NAME: CITY HALL PR E11 LIGHTING

DATE: 8/9/17 QUOTE NUMBER 052616DZPRE11

WE ARE PLEASED TO QUOTE THE FOLLOWING:
LIGHTIN AND LIGHTING CONTROL CHANGES FOR PR E11:

ADD SIX TYPE AS8"-0
DELETE FOUR TYPE AS8'-3
DELETE TWO TYPE AH8'-0
ADD TWO TYPE AH4"-0
DELETE ONE TYPE AS12'-0
ADD ONE TYPE ASE12"-0
ADD ONE TYPE AS12'-3
DELETE ONE TYPE AH12'-0
ADD TWO NETWORKED CEILING SENSORS
DELETE ONE WALL SENSOR AND WALL SWITCH

LOT ADDER FOR THE ABOVE CHANGES: ADD 1883.00LOT FOR THESE
CHANGES

THANK YOU

DEAN

CD TERMS: 1% 15 DAYS, NET 30. GRAYBAR ELECTRIC COMPANY'S
STANDARD TERMS AND CONDITIONS OF SALE APPLY. TERMS AND
CONDITIONS OF SALE ARE AVAILABLE UPON REQUEST. ABOVE QUOTE
IS FIRM FOR 30 DAYS. FOB: SHIPPING POINT-_____

LF-FAND-29



Data Technologies Inc.

Fargo: 705 Main Avenue Suite D • West Fargo, North Dakota 58078
(701) 282-7847 • FAX (701) 282-7623
Bismarck: 3355 Saratoga Avenue #4 • Bismarck, North Dakota 58503
Phone/Fax : (701) 223-2228

COMMERCIAL INSTALLATION, SALES AND SECURITY AGREEMENT AND PROMISSORY NOTE

Purchaser

Sun Electric

Address

411 39th Street NW

City/State/Zip

Fargo, ND 58102

Contact

Tyler

Project

Fargo City Hall – Change Order E11

Phone

701-281-9140

Consultant

Mark Vernon

Scope:

Received Change Order Request E11. Per the engineer in email communications I am to perform the actions detailed on the plans and not the write up because that is in error. The following changes will be made to the original bid.

- Sheet E4.3 Original Drawings – Remove the following cables
 - Open Office W105
 - Remove 2D location on common wall with Office W101.
 - Remove four (4) 4D Furniture locations on West Wall (one (1) right below grid line 9, the rest between grid line 7 and 9)
 - Office W106
 - Remove 2D outlet on south wall
 - Office W107
 - Remove 2D outlet on south wall
 - Office W108
 - Remove 2D outlet on south wall
- Sheet E4.3 Revised Drawings – Add the following Cables
 - New Office 106
 - Add 2D cables to the West wall
 - New Office 107
 - Add 2D cables to the West wall.
 - New Office 108
 - Add 2D cables to the West wall.
 - Open Office W105
 - Add 4D furniture location on common south wall with new office W106.
 - Add 2D wall location just south of room W104 on the East wall.
 - Add two (2) 4D furniture location on East wall.
- Sheet E4.4 Original Drawings – Remove the following cables
 - Office W127
 - Remove 2D outlet on East wall
 - Reception W128
 - Remove West most 4D furniture location

(Continued Page 2)

Electrical contractor responsible for all conduit, boxes, plywood, grounding bus bar, cable tray, fire rated penetrations.

TERMS: 30 days; 1.5% per month; 18% annual on past due balances. This quote is good for 30 days from date. Purchaser agrees to pay all collection costs if account balance is not paid in a timely manner. All material is guaranteed to be as specified. All work to be completed in a workmanlike manner according to a standard practices. Any alteration or deviation from above specifications involving extra costs will be executed only upon written orders, and will become an extra charge over and above the estimate. All agreements contingent upon strikes, accidents, or delays beyond our control. Owner to carry fire, tornado, and other necessary insurance. Our workers are fully covered by Workman's Compensation Insurance. NOTE: Will not work or be responsible for any cost involving asbestos.

ABT Data Technologies, Inc.

Sun Electric

By: Mark Vernon

By: _____

Date: August 23, 2017

Date: _____



Data Technologies Inc.

Fargo: 705 Main Avenue Suite D · West Fargo, North Dakota 58078
 (701) 282-7847 · FAX (701) 282-7623
 Bismarck: 3355 Saratoga Avenue #4 · Bismarck, North Dakota 58503
 Phone/Fax : (701) 223-2228

COMMERCIAL INSTALLATION, SALES AND SECURITY AGREEMENT AND PROMISSORY NOTE

The above detailed work ends up being a credit of 2,000 feet of the Category 6 Augmented cable, 10 Category 6 augmented jacks and 3 faceplates.

	Total
Materials	(\$1,143.00)
Labor	(\$462.00)
Total	(\$1,605.00)

Electrical contractor responsible for all conduit, boxes, plywood, grounding bus bar, cable tray, fire rated penetrations.

TERMS: 30 days; 1.5% per month; 18% annual on past due balances. This quote is good for 30 days from date. Purchaser agrees to pay all collection costs if account balance is not paid in a timely manner. All material is guaranteed to be as specified. All work to be completed in a workmanlike manner according to a standard practices. Any alteration or deviation from above specifications involving extra costs will be executed only upon written orders, and will become an extra charge over and above the estimate. All agreements contingent upon strikes, accidents, or delays beyond our control. Owner to carry fire, tornado, and other necessary insurance. Our workers are fully covered by Workman's Compensation Insurance. NOTE: Will not work or be responsible for any cost involving asbestos.

ABT Data Technologies, Inc.
 By: Mark Vernon

Date: August 23, 2017

Sun Electric
 By: _____

Date: _____



PROPOSAL REQUEST – E11

Date	06-29-17
Project #	2015231
Project Name	New Fargo City Hall
Project Location	Fargo, ND
Description	First Floor Office Revisions – Electrical Changes

Please submit an itemized quotation for the change(s) described below to the proposed modifications to the Contract Documents. Cost proposal to include a detailed itemized breakdown indicating the specific amounts, lengths, quantities, types, sizes, etc. of material including labor, O&P, taxes, and other incidental charges to be used. Proposal shall also indicate credits, deducts, and/or offsets for material and labor originally included in contract. THIS IS NOT A CHANGE ORDER OR DIRECTION TO PROCEED WITH WORK STATED HEREIN.

ITEM NO. 1 SHEET E2.3

W106 – Office

1. Office to be relocated to west side of area.
1. Low voltage dimmer switch and ceiling mounted occupancy sensor shall be relocated to new office location.
2. Delete luminaire type AH8'-0.
3. Provide (2) type AH4'-0 luminaires.

W107 – Office

1. Office to be relocated to west side of area.
2. Low voltage dimmer switch and ceiling mounted occupancy sensor shall be relocated to new office location.
3. Delete luminaire type AH8'-0.
4. Provide (2) type AS8'-0 luminaires.

W108 – Office

1. Office to be relocated to west side of area.
2. Low voltage dimmer switch and ceiling mounted occupancy sensor shall be relocated to new office location.
3. Delete luminaire type AH8'-0.
4. Provide (2) type AS8'-0 luminaires.

W105 – Open Office

1. Delete (3) type AS8'-3 from northwest corner of area.
2. Provide (3) type AS8'-0 to the east side of Open Office area. (Former location of offices W106, W107 and W108.)
3. Delete type AS12'-0 luminaire located at the south end of Open Office.
4. Provide type ASE12'-0 luminaire at the south end of Open Office in place of the deleted type AS12'-0 noted above. Connect luminaire to power circuits 'H12-2' and 'HEM12-1'. Connect luminaire to switching circuits 'na' and 'nd'.

BUILDING SYSTEMS CONSULTANTS

FARGO
2201 12th St. N Suite E
701.280.0500

GRAND FORKS
311 4th St. S Suite 203
701.775.2594

BISMARCK
233 West Rosser Ave.
701.222.0520

ALEXANDRIA
503 Howthorne St. Suite 141
320.846.0300

MINNEAPOLIS
1400 Van Buren St. NE Suite 130
877.390.0301

5. Provide two additional type DTCN ceiling mounted occupancy sensors. The first sensor located at the west side of Open Office and the second sensor located in the east side of Open Office.

W101 – Office

1. Delete type AH12'-0 luminaire.
2. Provide (2) type AH8'-0 luminaires.

ITEM NO. 2 SHEET E2.4

W127 - Office (Room to be deleted)

1. Delete luminaire type AH8'-0.
2. Delete stand-alone type DT90 ceiling mounted occupancy sensor.
3. Delete low voltage dimmer switch.

W128 - Reception

1. Add luminaire type AS12'-3.

ITEM NO. 3 SHEET E3.3

1. Modify device locations as indicated.
2. Provide (2) additional duplex receptacles. Circuit as indicated.

ITEM NO. 4 SHEET E3.4

1. Modify device locations as indicated.
2. Omit (1) additional duplex receptacles. Circuit as indicated.
3. Provide (1) additional furniture feed connection as indicated. Connect to spare 20/1 breaker at panel L13 (L13-50).

ITEM NO. 5 SHEET E4.3

1. Modify device locations as indicated.
2. Provide (1) additional furniture feed connection w/ 4D as indicated.

ITEM NO. 6 SHEET E4.4

1. Modify device locations as indicated.
2. Provide (1) additional furniture feed connection w/ 4D as indicated.
3. Provide rough-in only for (1) data outlet in lieu of 2D data outlet.

ITEM NO. 7 SHEET E5.3

1. Modify device locations as indicated.

ITEM NO. 8 SHEET E5.4

1. Modify device locations as indicated.

Respectfully,
Obermiller Nelson Engineering, Inc.

Tony Nelson

Attachment(s): Sheets E2.3, E2.4, E3.3, E3.4, E4.3, E4.4, E5.3, E5.4.
Cc: ONE File.

OBERMILLER NELSON ENGINEERING

FARGO

2201 12th St. N Suite E
701.280.0500

GRAND FORKS

311 4th St. S Suite 203
701.775.2594

BISMARCK

233 West Rosser Ave.
701.222.0520

ALEXANDRIA

503 Hawthorne St Suite 141
320.846.0300

MINNEAPOLIS

1400 Van Buren St. NE Suite 120
977.380.0501



8 Seventh St. N
FARGO, ND 58102
Office (701) 238-1185
Fax (701) 238-1186
www.strobe.com



Light & Color Inc. 415500
Light & Color Inc. 415500

Project:

NEW FARGO CITY HALL
CITY OF FARGO
Fargo, North Dakota

Location:
8 Seventh St. N.
Fargo, ND 58102

Drawn By:
Auditor

Date:
APRIL 22ND, 2016

Revision Date:
6-25-17

Job Number:
2015231

Sheet Name:
FIRST FLOOR LIGHTING PLAN - A

Sheet Number:
E2.3

- GENERAL NOTES:**
1. ALL DIMENSIONS SHOWN ARE IN METERS.
 2. ALL DIMENSIONS SHOWN ARE TO FACE UNLESS NOTED OTHERWISE.
 3. ALL DIMENSIONS SHOWN ARE TO FACE UNLESS NOTED OTHERWISE.
 4. ALL DIMENSIONS SHOWN ARE TO FACE UNLESS NOTED OTHERWISE.
 5. ALL DIMENSIONS SHOWN ARE TO FACE UNLESS NOTED OTHERWISE.
 6. ALL DIMENSIONS SHOWN ARE TO FACE UNLESS NOTED OTHERWISE.
 7. ALL DIMENSIONS SHOWN ARE TO FACE UNLESS NOTED OTHERWISE.
 8. ALL DIMENSIONS SHOWN ARE TO FACE UNLESS NOTED OTHERWISE.
 9. ALL DIMENSIONS SHOWN ARE TO FACE UNLESS NOTED OTHERWISE.
 10. ALL DIMENSIONS SHOWN ARE TO FACE UNLESS NOTED OTHERWISE.
 11. ALL DIMENSIONS SHOWN ARE TO FACE UNLESS NOTED OTHERWISE.
 12. ALL DIMENSIONS SHOWN ARE TO FACE UNLESS NOTED OTHERWISE.
 13. ALL DIMENSIONS SHOWN ARE TO FACE UNLESS NOTED OTHERWISE.
 14. ALL DIMENSIONS SHOWN ARE TO FACE UNLESS NOTED OTHERWISE.
 15. ALL DIMENSIONS SHOWN ARE TO FACE UNLESS NOTED OTHERWISE.
 16. ALL DIMENSIONS SHOWN ARE TO FACE UNLESS NOTED OTHERWISE.
 17. ALL DIMENSIONS SHOWN ARE TO FACE UNLESS NOTED OTHERWISE.
 18. ALL DIMENSIONS SHOWN ARE TO FACE UNLESS NOTED OTHERWISE.
 19. ALL DIMENSIONS SHOWN ARE TO FACE UNLESS NOTED OTHERWISE.
 20. ALL DIMENSIONS SHOWN ARE TO FACE UNLESS NOTED OTHERWISE.

- KEY NOTES:**
1. ALL DIMENSIONS SHOWN ARE IN METERS.
 2. ALL DIMENSIONS SHOWN ARE TO FACE UNLESS NOTED OTHERWISE.
 3. ALL DIMENSIONS SHOWN ARE TO FACE UNLESS NOTED OTHERWISE.
 4. ALL DIMENSIONS SHOWN ARE TO FACE UNLESS NOTED OTHERWISE.
 5. ALL DIMENSIONS SHOWN ARE TO FACE UNLESS NOTED OTHERWISE.
 6. ALL DIMENSIONS SHOWN ARE TO FACE UNLESS NOTED OTHERWISE.
 7. ALL DIMENSIONS SHOWN ARE TO FACE UNLESS NOTED OTHERWISE.
 8. ALL DIMENSIONS SHOWN ARE TO FACE UNLESS NOTED OTHERWISE.
 9. ALL DIMENSIONS SHOWN ARE TO FACE UNLESS NOTED OTHERWISE.
 10. ALL DIMENSIONS SHOWN ARE TO FACE UNLESS NOTED OTHERWISE.
 11. ALL DIMENSIONS SHOWN ARE TO FACE UNLESS NOTED OTHERWISE.
 12. ALL DIMENSIONS SHOWN ARE TO FACE UNLESS NOTED OTHERWISE.
 13. ALL DIMENSIONS SHOWN ARE TO FACE UNLESS NOTED OTHERWISE.
 14. ALL DIMENSIONS SHOWN ARE TO FACE UNLESS NOTED OTHERWISE.
 15. ALL DIMENSIONS SHOWN ARE TO FACE UNLESS NOTED OTHERWISE.
 16. ALL DIMENSIONS SHOWN ARE TO FACE UNLESS NOTED OTHERWISE.
 17. ALL DIMENSIONS SHOWN ARE TO FACE UNLESS NOTED OTHERWISE.
 18. ALL DIMENSIONS SHOWN ARE TO FACE UNLESS NOTED OTHERWISE.
 19. ALL DIMENSIONS SHOWN ARE TO FACE UNLESS NOTED OTHERWISE.
 20. ALL DIMENSIONS SHOWN ARE TO FACE UNLESS NOTED OTHERWISE.

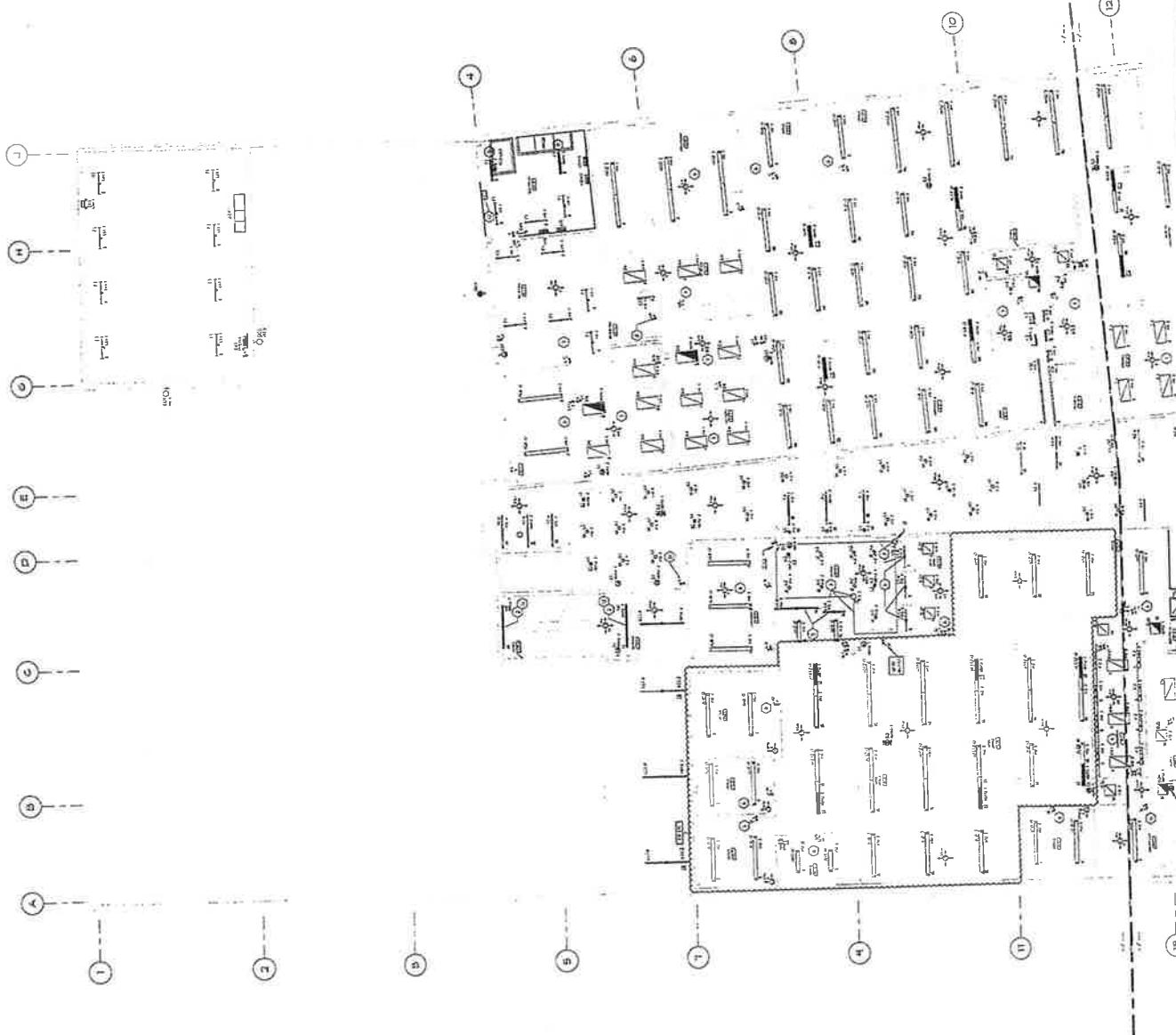

FIRST FLOOR LIGHTING PLAN - A



STROM
8 SEVENTH ST. N.
FARGO, ND 58102
Phone: (701) 233-1111
www.strom.com



ONE
Energy Partner | 2015/2016

Project:

NEW FARGO CITY HALL
CITY OF FARGO
Fargo, North Dakota

Location:
8 Seventh St. N.
Fargo, ND 58102

Drawn By:
ARV

Date:
APRIL 22ND, 2016

Revision Date:
6-29-17

Job Number:
2015231

Sheet Name:
FIRST FLOOR
POWER PLAN-A

Sheet Number:
E3.3

GENERAL NOTES:
1. REFER TO ALL SHEETS FOR CONNECTIONS AND DIMENSIONS.

- KEY NOTES:
1. ALL WORK SHALL BE IN ACCORDANCE WITH THE 2014 NORTH DAKOTA ELECTRICAL CODE AND ALL CITY ORDINANCES.
 2. ALL WORK SHALL BE IN ACCORDANCE WITH THE 2014 NORTH DAKOTA ELECTRICAL CODE AND ALL CITY ORDINANCES.
 3. ALL WORK SHALL BE IN ACCORDANCE WITH THE 2014 NORTH DAKOTA ELECTRICAL CODE AND ALL CITY ORDINANCES.
 4. ALL WORK SHALL BE IN ACCORDANCE WITH THE 2014 NORTH DAKOTA ELECTRICAL CODE AND ALL CITY ORDINANCES.
 5. ALL WORK SHALL BE IN ACCORDANCE WITH THE 2014 NORTH DAKOTA ELECTRICAL CODE AND ALL CITY ORDINANCES.
 6. ALL WORK SHALL BE IN ACCORDANCE WITH THE 2014 NORTH DAKOTA ELECTRICAL CODE AND ALL CITY ORDINANCES.
 7. ALL WORK SHALL BE IN ACCORDANCE WITH THE 2014 NORTH DAKOTA ELECTRICAL CODE AND ALL CITY ORDINANCES.
 8. ALL WORK SHALL BE IN ACCORDANCE WITH THE 2014 NORTH DAKOTA ELECTRICAL CODE AND ALL CITY ORDINANCES.
 9. ALL WORK SHALL BE IN ACCORDANCE WITH THE 2014 NORTH DAKOTA ELECTRICAL CODE AND ALL CITY ORDINANCES.
 10. ALL WORK SHALL BE IN ACCORDANCE WITH THE 2014 NORTH DAKOTA ELECTRICAL CODE AND ALL CITY ORDINANCES.
 11. ALL WORK SHALL BE IN ACCORDANCE WITH THE 2014 NORTH DAKOTA ELECTRICAL CODE AND ALL CITY ORDINANCES.
 12. ALL WORK SHALL BE IN ACCORDANCE WITH THE 2014 NORTH DAKOTA ELECTRICAL CODE AND ALL CITY ORDINANCES.
 13. ALL WORK SHALL BE IN ACCORDANCE WITH THE 2014 NORTH DAKOTA ELECTRICAL CODE AND ALL CITY ORDINANCES.
 14. ALL WORK SHALL BE IN ACCORDANCE WITH THE 2014 NORTH DAKOTA ELECTRICAL CODE AND ALL CITY ORDINANCES.
 15. ALL WORK SHALL BE IN ACCORDANCE WITH THE 2014 NORTH DAKOTA ELECTRICAL CODE AND ALL CITY ORDINANCES.
 16. ALL WORK SHALL BE IN ACCORDANCE WITH THE 2014 NORTH DAKOTA ELECTRICAL CODE AND ALL CITY ORDINANCES.
 17. ALL WORK SHALL BE IN ACCORDANCE WITH THE 2014 NORTH DAKOTA ELECTRICAL CODE AND ALL CITY ORDINANCES.
 18. ALL WORK SHALL BE IN ACCORDANCE WITH THE 2014 NORTH DAKOTA ELECTRICAL CODE AND ALL CITY ORDINANCES.
 19. ALL WORK SHALL BE IN ACCORDANCE WITH THE 2014 NORTH DAKOTA ELECTRICAL CODE AND ALL CITY ORDINANCES.
 20. ALL WORK SHALL BE IN ACCORDANCE WITH THE 2014 NORTH DAKOTA ELECTRICAL CODE AND ALL CITY ORDINANCES.



FIRST FLOOR POWER PLAN-A



8 Seventh St. N.
Fargo, ND 58102
Tel: (701) 228-1188
Fax: (701) 228-8543
www.stroh.com



One • Good • Done • Done Right

Project:

NEW FARGO CITY HALL
CITY OF FARGO
Fargo, North Dakota

Location:
1000 1st St. N.
3rd Floor
Fargo, ND 58102

Drawn By:
ARN

Date:
APRIL 22ND, 2016

Revision Date:
6-28-17

Issue Number:
2016231

Sheet Name:
FIRST FLOOR
TELECOMMUNICATIONS
PLAN-A

Sheet Number:
E4.3

GENERAL NOTES:

1. SEE ALL GENERAL NOTES AND SPECIFICATIONS FOR THE PROJECT.
2. ALL TELECOMMUNICATIONS SHALL BE INSTALLED IN ACCORDANCE WITH THE CITY OF FARGO TELECOMMUNICATIONS SPECIFICATIONS.
3. ALL TELECOMMUNICATIONS SHALL BE INSTALLED IN ACCORDANCE WITH THE CITY OF FARGO TELECOMMUNICATIONS SPECIFICATIONS.
4. ALL TELECOMMUNICATIONS SHALL BE INSTALLED IN ACCORDANCE WITH THE CITY OF FARGO TELECOMMUNICATIONS SPECIFICATIONS.
5. ALL TELECOMMUNICATIONS SHALL BE INSTALLED IN ACCORDANCE WITH THE CITY OF FARGO TELECOMMUNICATIONS SPECIFICATIONS.
6. ALL TELECOMMUNICATIONS SHALL BE INSTALLED IN ACCORDANCE WITH THE CITY OF FARGO TELECOMMUNICATIONS SPECIFICATIONS.
7. ALL TELECOMMUNICATIONS SHALL BE INSTALLED IN ACCORDANCE WITH THE CITY OF FARGO TELECOMMUNICATIONS SPECIFICATIONS.
8. ALL TELECOMMUNICATIONS SHALL BE INSTALLED IN ACCORDANCE WITH THE CITY OF FARGO TELECOMMUNICATIONS SPECIFICATIONS.
9. ALL TELECOMMUNICATIONS SHALL BE INSTALLED IN ACCORDANCE WITH THE CITY OF FARGO TELECOMMUNICATIONS SPECIFICATIONS.
10. ALL TELECOMMUNICATIONS SHALL BE INSTALLED IN ACCORDANCE WITH THE CITY OF FARGO TELECOMMUNICATIONS SPECIFICATIONS.

KEY NOTES:

1. TELECOMMUNICATIONS SHALL BE INSTALLED IN ACCORDANCE WITH THE CITY OF FARGO TELECOMMUNICATIONS SPECIFICATIONS.
2. TELECOMMUNICATIONS SHALL BE INSTALLED IN ACCORDANCE WITH THE CITY OF FARGO TELECOMMUNICATIONS SPECIFICATIONS.
3. TELECOMMUNICATIONS SHALL BE INSTALLED IN ACCORDANCE WITH THE CITY OF FARGO TELECOMMUNICATIONS SPECIFICATIONS.
4. TELECOMMUNICATIONS SHALL BE INSTALLED IN ACCORDANCE WITH THE CITY OF FARGO TELECOMMUNICATIONS SPECIFICATIONS.
5. TELECOMMUNICATIONS SHALL BE INSTALLED IN ACCORDANCE WITH THE CITY OF FARGO TELECOMMUNICATIONS SPECIFICATIONS.
6. TELECOMMUNICATIONS SHALL BE INSTALLED IN ACCORDANCE WITH THE CITY OF FARGO TELECOMMUNICATIONS SPECIFICATIONS.
7. TELECOMMUNICATIONS SHALL BE INSTALLED IN ACCORDANCE WITH THE CITY OF FARGO TELECOMMUNICATIONS SPECIFICATIONS.
8. TELECOMMUNICATIONS SHALL BE INSTALLED IN ACCORDANCE WITH THE CITY OF FARGO TELECOMMUNICATIONS SPECIFICATIONS.
9. TELECOMMUNICATIONS SHALL BE INSTALLED IN ACCORDANCE WITH THE CITY OF FARGO TELECOMMUNICATIONS SPECIFICATIONS.
10. TELECOMMUNICATIONS SHALL BE INSTALLED IN ACCORDANCE WITH THE CITY OF FARGO TELECOMMUNICATIONS SPECIFICATIONS.

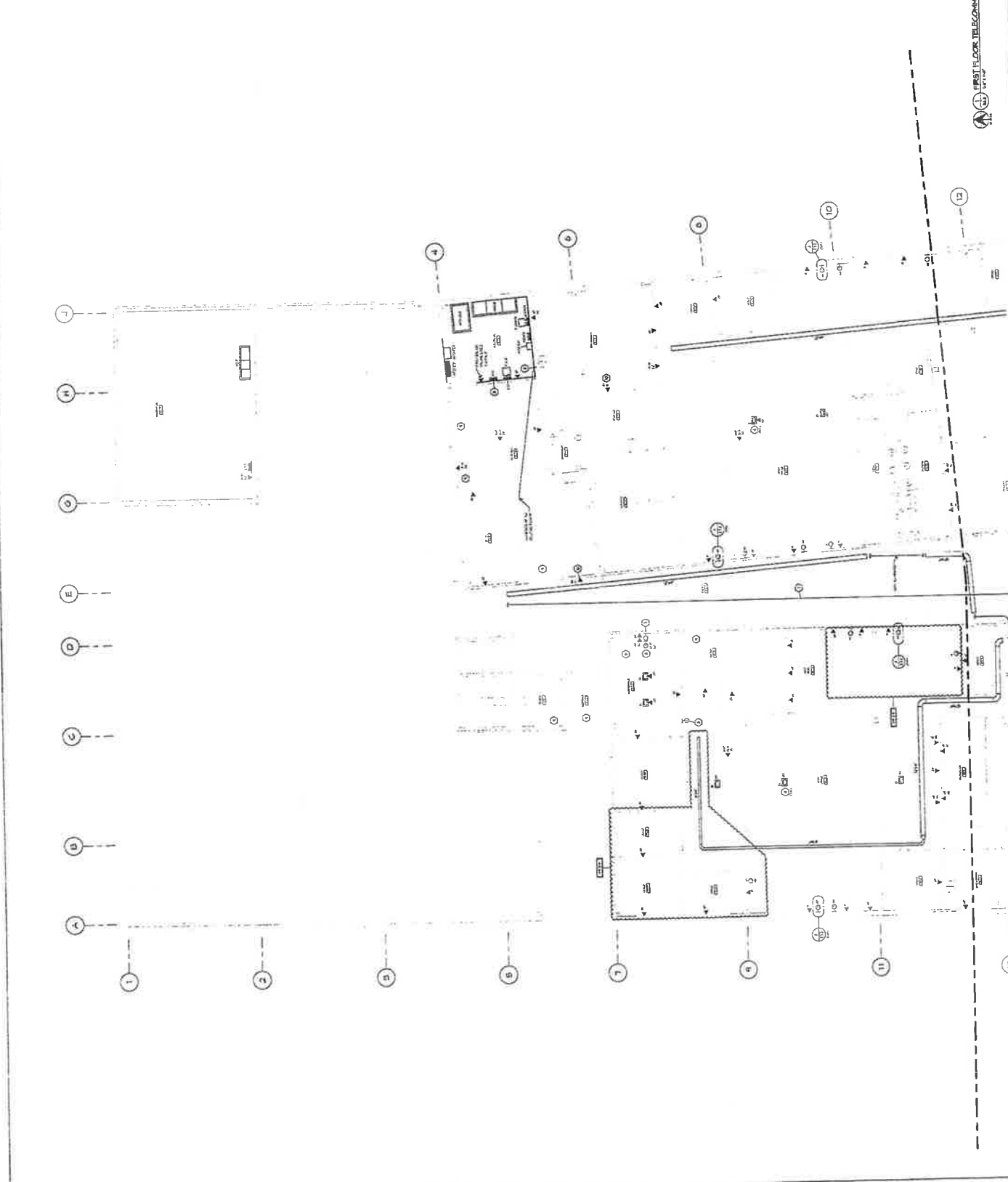

FIRST FLOOR TELECOMMUNICATIONS PLAN-A



STROH
ELECTRICAL CONTRACTORS
8 SEVENTH ST. N.
FARGO, ND 58102
PHONE (701) 238-4154
FAX (701) 238-6423
www.strohelect.com



ONE
Buy & Sell And - 2 Month
Term Contracting - 2011/11/11

Project:

NEW FARGO CITY HALL
CITY OF FARGO
Fargo, North Dakota
Location:
8 Seventh St. N.
Fargo, ND 58102
Drawn By:
ARN
Date:
APRIL 22ND, 2016
Revision Date:
6-28-17
Job Number:
2015231
Sheet Name: ELECT
SAFETY & SECURITY
PLAN - A
Sheet Number:
E5.3

GENERAL NOTES:
1. THE CONTRACTOR SHALL BE RESPONSIBLE FOR OBTAINING ALL NECESSARY PERMITS AND APPROVALS FROM THE CITY OF FARGO AND THE NORTH DAKOTA DEPARTMENT OF LABOR AND INDUSTRY.
2. THE CONTRACTOR SHALL BE RESPONSIBLE FOR OBTAINING ALL NECESSARY PERMITS AND APPROVALS FROM THE CITY OF FARGO AND THE NORTH DAKOTA DEPARTMENT OF LABOR AND INDUSTRY.
3. THE CONTRACTOR SHALL BE RESPONSIBLE FOR OBTAINING ALL NECESSARY PERMITS AND APPROVALS FROM THE CITY OF FARGO AND THE NORTH DAKOTA DEPARTMENT OF LABOR AND INDUSTRY.
4. THE CONTRACTOR SHALL BE RESPONSIBLE FOR OBTAINING ALL NECESSARY PERMITS AND APPROVALS FROM THE CITY OF FARGO AND THE NORTH DAKOTA DEPARTMENT OF LABOR AND INDUSTRY.
5. THE CONTRACTOR SHALL BE RESPONSIBLE FOR OBTAINING ALL NECESSARY PERMITS AND APPROVALS FROM THE CITY OF FARGO AND THE NORTH DAKOTA DEPARTMENT OF LABOR AND INDUSTRY.
6. THE CONTRACTOR SHALL BE RESPONSIBLE FOR OBTAINING ALL NECESSARY PERMITS AND APPROVALS FROM THE CITY OF FARGO AND THE NORTH DAKOTA DEPARTMENT OF LABOR AND INDUSTRY.
7. THE CONTRACTOR SHALL BE RESPONSIBLE FOR OBTAINING ALL NECESSARY PERMITS AND APPROVALS FROM THE CITY OF FARGO AND THE NORTH DAKOTA DEPARTMENT OF LABOR AND INDUSTRY.
8. THE CONTRACTOR SHALL BE RESPONSIBLE FOR OBTAINING ALL NECESSARY PERMITS AND APPROVALS FROM THE CITY OF FARGO AND THE NORTH DAKOTA DEPARTMENT OF LABOR AND INDUSTRY.
9. THE CONTRACTOR SHALL BE RESPONSIBLE FOR OBTAINING ALL NECESSARY PERMITS AND APPROVALS FROM THE CITY OF FARGO AND THE NORTH DAKOTA DEPARTMENT OF LABOR AND INDUSTRY.
10. THE CONTRACTOR SHALL BE RESPONSIBLE FOR OBTAINING ALL NECESSARY PERMITS AND APPROVALS FROM THE CITY OF FARGO AND THE NORTH DAKOTA DEPARTMENT OF LABOR AND INDUSTRY.

KEY NOTES:
1. ALL WORK SHALL BE IN ACCORDANCE WITH THE CITY OF FARGO ELECTRICAL CODE AND THE NORTH DAKOTA ELECTRICAL CODE.
2. ALL WORK SHALL BE IN ACCORDANCE WITH THE CITY OF FARGO ELECTRICAL CODE AND THE NORTH DAKOTA ELECTRICAL CODE.
3. ALL WORK SHALL BE IN ACCORDANCE WITH THE CITY OF FARGO ELECTRICAL CODE AND THE NORTH DAKOTA ELECTRICAL CODE.
4. ALL WORK SHALL BE IN ACCORDANCE WITH THE CITY OF FARGO ELECTRICAL CODE AND THE NORTH DAKOTA ELECTRICAL CODE.
5. ALL WORK SHALL BE IN ACCORDANCE WITH THE CITY OF FARGO ELECTRICAL CODE AND THE NORTH DAKOTA ELECTRICAL CODE.
6. ALL WORK SHALL BE IN ACCORDANCE WITH THE CITY OF FARGO ELECTRICAL CODE AND THE NORTH DAKOTA ELECTRICAL CODE.
7. ALL WORK SHALL BE IN ACCORDANCE WITH THE CITY OF FARGO ELECTRICAL CODE AND THE NORTH DAKOTA ELECTRICAL CODE.
8. ALL WORK SHALL BE IN ACCORDANCE WITH THE CITY OF FARGO ELECTRICAL CODE AND THE NORTH DAKOTA ELECTRICAL CODE.
9. ALL WORK SHALL BE IN ACCORDANCE WITH THE CITY OF FARGO ELECTRICAL CODE AND THE NORTH DAKOTA ELECTRICAL CODE.
10. ALL WORK SHALL BE IN ACCORDANCE WITH THE CITY OF FARGO ELECTRICAL CODE AND THE NORTH DAKOTA ELECTRICAL CODE.



FIRST FLOOR ELECTRICAL SAFETY & SECURITY PLAN - A

14a-b



IMAGE Group Architecture & Interiors

October 6, 2017

Richard Moorhead AIA, NCARB

City of Fargo Police Department 222 4th Street North Fargo, North Dakota 58102 Attention: Deputy Chief Anderson

RE: City of Fargo BSE Police Department Remodeling Fargo, North Dakota Image 1703

Marcia Pulczynski AIA, NCARB, LEED AP

Dear Deputy Chief Anderson;

Enclosed please find three (3) copies each of AIA Document G701 Change Orders M-1 in the amount of \$4,080.00 and E-3 in the amount of \$1,406.45 for the above referenced project.

225 Fourth Avenue North Suite 3 Fargo North Dakota 58102

If the documents meet with your approval please obtain appropriate signatures and return Architect's and Contractor's copies to this office.

Sincerely,

IMAGE GROUP, INC.

[Handwritten signature]

403 Center Avenue Suite 300 Moorhead Minnesota 56560

Richard A. Moorhead, NCARB, AIA

IG: jrg

Enc.

Telephone 218.233.2062

Facsimile 218.233.2575

AIA® Document G701™ – 2001

Change Order

PROJECT: <i>(Name and address)</i> City of Fargo BSE Police Department Remodeling Fargo, ND	CHANGE ORDER NUMBER: E-3 DATE: September 29, 2017	OWNER <input type="checkbox"/> ARCHITECT <input type="checkbox"/> CONTRACTOR <input type="checkbox"/> FIELD <input type="checkbox"/> OTHER <input type="checkbox"/>
TO CONTRACTOR: <i>(Name and address)</i> CB & Sons Electric, Inc. 1020 Center Ave. Moorhead, MN 56560	ARCHITECT'S PROJECT NUMBER: 1703 CONTRACT DATE: May 19, 2017 CONTRACT FOR: Electrical Construction	

The Contract is changed as follows:

(Include, where applicable, any undisputed amount attributable to previously executed Construction Change Directives.)

- | | | |
|---|-----|-----------------|
| 1. ADD GFI receptacles at RTU-1, RTU-2 and MAH-1 (ASI-E8). | ADD | \$940.05 |
| 2. REVISE cable terminations as requested by City of Fargo IT Department. | ADD | <u>\$466.40</u> |

TOTAL ADD \$1,406.45

The original (Contract Sum) (XXXXXXXXXXXXXXX) was	\$	<u>215,900.00</u>
The net change by previously authorized Change Orders	\$	<u>28,089.96</u>
The (Contract Sum) (XXXXXXXXXXXXXXX) prior to this Change Order was	\$	<u>243,989.96</u>
The (Contract Sum) (XXXXXXXXXXXXXXX) will be (increased) (XXXXXXXXXXXXXXX) by this Change Order in the amount of	\$	<u>1,406.45</u>
The new (Contract Sum) (XXXXXXXXXXXXXXX) , including this Change Order, will be	\$	<u>245,396.41</u>
The Contract Time will be (increased/decreased) (unchanged) by zero		(0) days.

The date of Substantial Completion as of the date of this Change Order, therefore, is unchanged

NOTE: This Change Order does not include changes in the Contract Sum, Contract Time or Guaranteed Maximum Price that have been authorized by Construction Change Directive until the cost and time have been agreed upon by both the Owner and Contractor, in which case a Change Order is executed to supersede the Construction Change Directive.

NOT VALID UNTIL SIGNED BY THE ARCHITECT, CONTRACTOR AND OWNER.

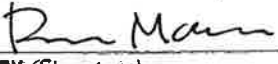
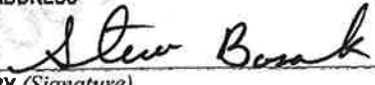
<u>Image Group, Inc.</u> ARCHITECT <i>(Firm name)</i> 403 Center Avenue, #300 Moorhead, MN / 56560 ADDRESS  BY <i>(Signature)</i> <u>Richard Moorhead</u> (Typed name) <u>OCTOBER 6, 2017</u> DATE	<u>CB & Sons Electric, Inc.</u> CONTRACTOR <i>(Firm name)</i> 1020 Center Avenue Moorhead, MN 56560 ADDRESS  BY <i>(Signature)</i> <u>Steve Basak</u> (Typed name) <u>10-4-2017</u> DATE	<u>City of Fargo</u> OWNER <i>(Firm name)</i> 200 North 3rd Street Fargo, ND 58102 ADDRESS BY <i>(Signature)</i> (Typed name) DATE
---	--	---

CAUTION: You should sign an original AIA Contract Document, on which this text appears in RED. An original assures that changes will not be obscured.



403 Center Avenue / Suite 300 / Moorhead, Minnesota 56560

Architect's Supplemental Instructions

ASI-E8

PROJECT/OWNER: BSE Police Department Remodeling
Fargo, North Dakota

ARCHITECT'S PROJECT NUMBER: 1703

TO: CB & Sons Electric, Inc.
1020 Center Avenue
Moorhead, MN 56560

CONTRACT FOR: Electrical Construction

DATE: August 18, 2017

The work shall be carried out in accordance with the following supplemental instructions issued in accordance with the Contract Documents. Proceeding with the Work in accordance with these instructions indicates your acknowledgment that there will be no change in the Contract Sum or Contract Time.

DESCRIPTION:

ROOF-TOP EQUIPMENT OUTLETS

1. Provide a receptacle on the roof at each air handling unit: RTU-1, RTU-2 and MAU-1.
2. Receptacle shall be weatherproof type with in-use cover.
3. Mount to the unit. Provide galvanized unistrut for mounting as necessary.
4. Connect to an adequate convenience outlet circuit nearby.

ISSUED BY:

A handwritten signature in black ink, appearing to read "Paul Mauer".

IMAGE Group Architecture & Interiors

CB & SONS ELECTRIC INC.

1020 Center Ave
Moorhead, MN 56560
Phone (218) 233-4775
Fax (218) 233-1938

Steven Bosak, President
Greg Bosak, Vice President
Doug Bosak, Vice President

August 22, 2017

Image Group
403 Center Avenue
Moorhead, MN

Attn: Mr. Richard Moorhead

Re: BSE/Police department
ASI-E8

To add GFI receptacles by the new roof top units RTU-1 RTU-2 & MAU-1

Cost breakdown:

3 Midwest boxes with GFI receptacle and inuse cover @ \$ 58.50 each	\$ 175.50
Conduit, boxes and wire	148.00
Labor 9 hours @ 50.00 each	<u>450.00</u>
	773.50
10 % Overhead	77.35
6 % Profit	51.05
Taxes	24.26
Bond @ 1.5 %	<u>13.89</u>
Total cost to add these receptacles	\$ 940.05

Sincerely,

CB & SONS ELECTRIC, INC.

Steven Bosak, President

1020 Center Ave
Moorhead, MN 56580
Phone (218) 233-4775
Fax (218) 233-1938

Steven Bosak, President
Greg Bosak, Vice President
Doug Bosak, Vice President

September 14, 2017

Image Group
403 center Ave
Moorhead, MN

Attn: Mr. Richard Moorhead

Re: BSE/Police department
Extra charges for terminating the fiber cable

I received a phone call yesterday from Mike Ronnie with Arvig he told me that Ron Gronneberg requested some changes to how the fiber cable was to be terminated. Mike told me that they have already made the requested changes and that there are additional charges. I have included the letter from Arvig detailing the changes and cost plus the correspondence between Arvig and Mr. Gronneberg.

I understand this is not how this is supposed to work but this is how it did work.

Cost breakdown

Arvig	\$ 400.00
Labor	0.00
10 % Overhead	40.00
6 % Profit	<u>26.40</u>
Total cost associated with this change	\$ 466.40

Sincerely

CB & SONS ELECTRIC, INC.



Steven Bosak, President

Proposal

Wednesday July 12, 2017

RE: BSE Police Department Remodeling; Change order discussion with Ron Gronneberg

Per discussion with Ron Gronneberg we decided to remove a 6" vertical management on the wall side of the New IT closet in the police Station. Upon further discussion Ron wanted to change the terminations from 24 in the Public works building to 48. Then in the new IT closet in the Police station just terminate 4 strands. With 48 terminations in the Public works building we would need to add a larger fiber panel. Details below:

Changes:

- Deduct 6" Vertical manager on wall side of rack to make additional room to get behind rack
 - Per email conversation with Ron Gronneberg September 6th 2017
- Deduct/ADD Fiber Panel In Public Works building from a 1U to a 2U shop drawing attached
 - Per Email conversation with ron Gronneberg September 13th 2017
- Change Terminations – Instead of terminating 24 strands in PW building and 24 Strands in Police building we will Terminate 48 Strands In Public works building
 - Per Email conversation with Ron Gronneberg September 13th 2017
- Add 4 Terminations In Police building
 - Per Email conversation with Ron Gronneberg September 13th 2017
- Add 4 Corning Unicam fiber connectors (Corning Unicam 95-201-98-SP Same material as originally approved)
- Add 1 Bulk head (Panduit FAP6WBudlcz FAP Same material as originally Approved)
- Add 1 Panduit Fan out kit

Exclusions:

- Any other material other than specified above.

Clarifications:

- Arvig is an approved installer.
- All work shall be completed in a workman-like manner and will meet or exceed all requirements of local and state regulations.
- All work shall be performed during normal working hours.
- Before any work or expenses are put into place Arvig will need a purchase order number or signature.

Total \$400.00

Sincerely,
 Mike Ronnie
 Estimator
 (O) 701-318-9914
 (C) 701-212-6627
 mike.ronnie@arvig.com



Authorization to Proceed _____

Date _____

P.O # _____

Per our conversation this morning, we will switch the 1u fiber panel in the Public Works building to a 2U. We will terminate all 48 strands in the public works building and 4 strands in the new IT Closet at the Police station.

Here is the cabinet in the upper mezzanine. We could put the new fiber panel above or below the existing and the 48 port patch panel below the other 3 patch panels. If you want it completely reorganized we would take care of it however you want.

Thanks,

Mike Ronnie
701-318-9914

Ron Gronneberg <RGronneberg@fargond.gov>

10:17 AM (6 hours ago)

to me, Nick

I would like to keep the fiber patch panels all together, hopefully at the top of the rack.

Matt has finished arranging the rack at the Public Works building and has freed up 4 U of space, so there is ample space for the new 2U rack. I'm very happy with the adjustment to terminate all 48 in the Public Works rack end and just 4 in the new PD location.

Thanks,

-Ron

When we last spoke we had discussed moving the Data rack from the West wall to the East wall. We didn't discuss the door access system (note 22 on the print) in discussions this morning we were looking at the clearance to access the door panel. We are looking at a 14" walkway to get behind the data rack. We were now thinking that leaving the rack on the west wall and moving the access panel from behind the data rack to in front of the data rack (like in the second image)

My questions and comments for you:

Would Fargo be ok with changing the location of the rack and access panel?

We will have only 14" to get between the wall and the data rack (closet is 46" wide. Rack is 20" wide with (2) 6" vertical managements)

The power for the rack is standard 20A do you want or require a 30A outlet?

Thanks
Mike Ronnie
701-306-2488

Ron Gronneberg <RGronneberg@fargond.gov>

Sep 6 (7 days ago)

to Tony, me

Hi, Mike,

I'm fine with having the rack on the west wall. Given the space constraints, I would like to remove the 6" of cable management on the wall side of the rack. So mount the rack 5" closer to the wall, which will gain us additional space to get behind the rack.

I am also comfortable with moving the Access Panel from behind the rack to in front of the rack. I would like to minimize any conflicts between mounting things in the rack and the Access Panel, though. So, I think the Access Panel should be mounted high, reasonably close to the corner, and, as far from the front of the rack as possible. I just don't want to block being able to slide things in to the rack. I don't think the Access Panel will be a problem for accessing the patch panels mounted on the rack.

20A outlet should work fine for our needs.

-Ron



403 Center Avenue / Suite 300 / Moorhead, Minnesota 56560

Architect's Supplemental Instructions

ASI-M1

PROJECT/OWNER: BSE Police Department Remodeling
Fargo, North Dakota

ARCHITECT'S PROJECT NUMBER: 1703

TO: Peterson Mechanical, Inc.
3001 First Avenue North
Fargo, ND 58102

CONTRACT FOR: Mechanical Construction

DATE: June 30, 2017

The work shall be carried out in accordance with the following supplemental instructions issued in accordance with the Contract Documents. Proceeding with the Work in accordance with these instructions indicates your acknowledgment that there will be no change in the Contract Sum or Contract Time.

DESCRIPTION:

PROVIDE S-1 FIXTURE in BREAKROOM 108

Provide and install S-1 fixture in Breakroom 108 as shown below. Specifications for S-1 fixture located in the project specifications 22 0400 2.15. Run new 1-1/2" waste line and 1/2" hot water line in wall. Connect 1-1/2" waste line for S-1 fixture into existing waste near floor in Toilet Room 106C. Connect 1/2" HW for new S-1 fixture to the existing water heater.

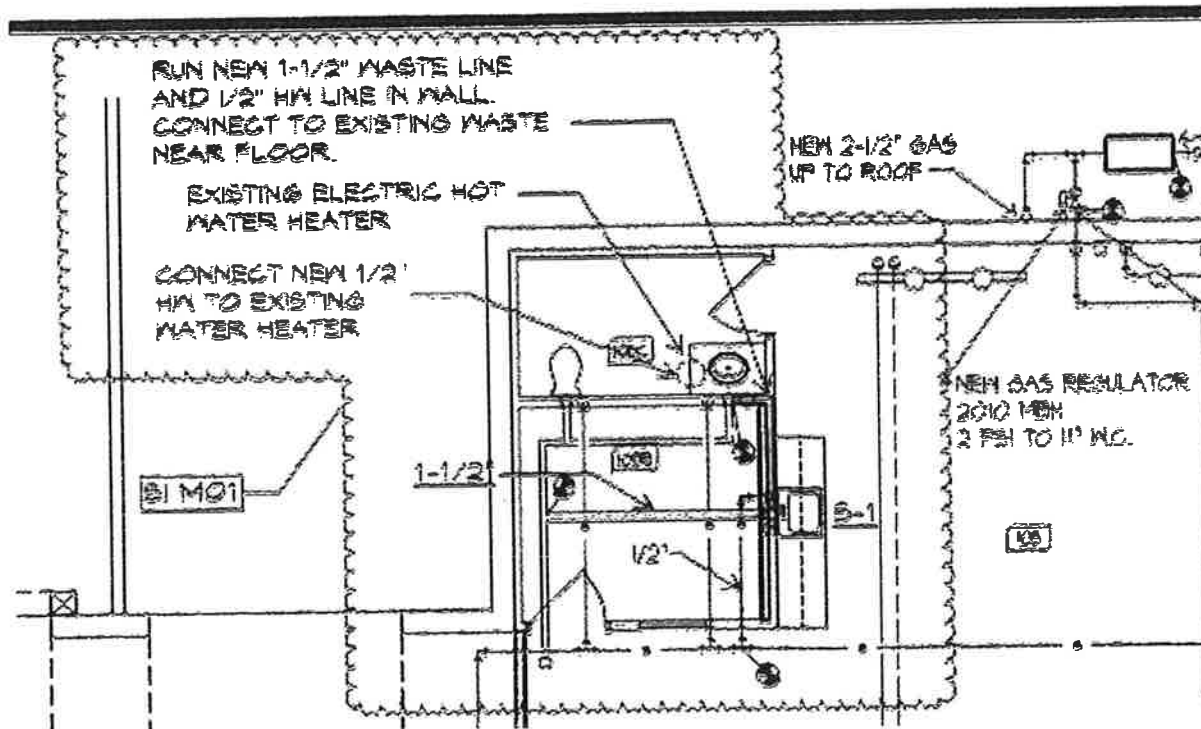

ISSUED BY:

Ricardo Morales

IMAGE Group Architecture & Interiors

PETERSON MECHANICAL, INC.

P.O. Box 302 • 3001 1st Avenue North • Phone 293-7206 • FAX 293-8683
Fargo, North Dakota 58107

July 30, 2017

Image Group
403 Center Avenue
Moorhead, MN 56560

Attn: Richard Moorhead

Re: BSE Police Department Remodeling

The following are the additional cost to furnish and install an S-1 sink in breakroom 108 per ASI-M1.

Labor 20 hours @ \$75.00	\$1,500.00
Material	985.00
Tax	74.00
10% overhead and profit	256.00
Insulation subcontractor	240.00
5% subcontractor mark-up	<u>12.00</u>
Total	\$3,067.00

Wall cutting and patching not included.

If you have any questions please let me know.

Michael D. Peterson

JOB 343 343: City of Fargo Police Depart...
 ESTIMATE 1 343: City of Fargo Police Depart...
 DATA SET 3 Discounted pricing

Summary
 (Company Name)
 (Company Address 1)
 (Company Address 2)
 (Company Address 3)
 (Company Phone) / (Company Fax)
 (Company Email)

REPORT RUN 7/30/2017 7:45:51 AM

NOTES

Item				Material		Field Labor	
Category	Size	Item Desc	Qty U...	Mat Unit	Mat Ext	Fld Unit	Fld Ext
		S-1 Sink	1.00 ea	790.00	790.00	2.5000	2.5000
PVC SCH 40-DWV	1-1/2"	PIPE-SCH 40 PVC DWV	30.00'	0.60	18.00	0.0550	1.6500
PVC SCH 40-DWV	1-1/2"	1/4 BEND - HxH	1.00 ea	1.12	1.12	0.4400	0.4400
PVC SCH 40-DWV	2" x 1-1/2" x 1-1/2"	SAN TEE X 3 HXHxH	1.00 ea	2.52	2.52	0.6600	0.6600
PVC SCH 40-DWV	1-1/2"	SAN TEE - HxHxH	1.00 ea	1.94	1.94	0.6600	0.6600
PVC SCH 40-DWV	Unsize	CEMENT AND PRIMER -PVC-...	0.18 ea	32.12	5.69	Skip	0.0000
PVC SCH 40-DWV	1-1/2"	L.S. 1/4 BEND - HxH	2.00 ea	2.58	5.16	0.4400	0.8800
PVC SCH 40-DWV	2" x 1-1/2"	RED WYE - HxHxH	1.00 ea	4.29	4.29	0.7040	0.7040
PVC SCH 40-DWV	2" x 1-1/2"	RED SAN TEE - HxHxH	1.00 ea	2.53	2.53	0.7040	0.7040
PVC SCH 40-DWV	2"	TEST TEE-W/PLUG	1.00 ea	6.15	6.15	0.7260	0.7260
PVC SCH 40-DWV	1-1/2"	COUPLING - HxH	1.50 ea	0.52	0.78	0.2000	0.3000
PVC SCH 40-DWV	2"	MISSION COUP	1.00 ea	7.60	7.60	0.2200	0.2200
PVC SCH 40-DWV	1-1/2"	MISSION COUP	1.00 ea	7.60	7.60	0.2000	0.2000
COPPER KLM-LEAD FREE	1/2"	L-HARD TUBE	40.00'	1.94	77.60	0.0400	1.6000
COPPER KLM-LEAD FREE	1/2"	90 ELBOW CxC	10.00 ea	0.83	8.30	0.4000	4.0000
COPPER KLM-LEAD FREE	1/2"	COUPLING	2.00 ea	0.62	1.24	Skip	0.0000
COPPER KLM-LEAD FREE	Unsize	SOLDER LBS-LEAD FREE	0.10 ea	31.77	3.27	Skip	0.0000
COPPER KLM-LEAD FREE	Unsize	PRESTOLITE-#2 CYL.	0.02 ea	9.50	0.20	Skip	0.0000
COPPER KLM-LEAD FREE	1" x 1/2"	REDUCED TEE - BRANCH	2.00 ea	10.37	20.74	0.7000	1.4000
COPPER KLM-LEAD FREE	Unsize	FLUX-2 OZ. CAN	0.10 ea	2.30	0.24	Skip	0.0000
COPPER KLM-LEAD FREE	Unsize	ABRASIVE CLOTH-25YD	0.00 ea	10.11	0.04	Skip	0.0000
HANGER-R.CLAMP-ETC.	1-1/2"	SWIVEL LOOP HGR-GAL.	2.00 ea	0.40	0.80	0.5000	1.0000
HANGER-R.CLAMP-ETC.	1/2"	SWIVEL LOOP HGR-C.T.	4.00 ea	0.66	2.64	0.5000	2.0000
HANGER-R.CLAMP-ETC.	3/8"	BEAM CLAMP	6.00 ea	0.85	5.10	Skip	0.0000
HANGER-R.CLAMP-ETC.	3/8"	ALL THREAD ROD	30.00 ea	0.38	11.40	Skip	0.0000
Grand Totals					984.94		19.6440

PETERSON MECHANICAL, INC.

3001 1st Avenue North • Fargo, North Dakota 58102 Phone 293-7206 • FAX 293-8683

August 21, 2017

Image Group
403 Center Avenue
Moorhead, MN 56560

RE: BSE Police Department ASI M2

The following is our cost breakdown for the work associated with ASI M2.

Sheet Metal Labor 8 hrs @65.00 hr	\$520.00
Sheet Metal Material	\$223.00
Sales Tax	\$16.00
10% Overhead and Profit	\$76.00
Thermal Insulation Subcontract	\$170.00
5% Subcontractor Mark-Up	<u>\$8.00</u>
TOTAL ASI M2	\$1,013.00

Respectfully submitted



Steve Fradet
HVAC Estimator

JOB 874 5-17-2017: BSE POLICE ST...
 ESTIMATE 1 5-17-2017: BSE POLICE ST...
 DATA SET 1 COMM SMACNA 10/07

D. Old Style Report
 PETERSON MECHANICAL, INC.
 3001 1ST AVENUE NORTH
 FARGO, ND 58102
 701-293-7206 / 701-293-8683
 sfradet@petersonmech.com

PRINTED 8/21/2017 6:17:36 AM
 MATERIAL Primary
 LABOR Primary

NOTES

Item				Material		Field Labor		Shop Labor	
Category	Size	Item Desc	Qty	Mat Unit	Mat Ext	Fld Unit	Fld Ext	Shp Unit	Shp Ext
GALV SPIRAL PIPE	8"	28 GA. GALV	25.00	3.34	83.50	0.0640	1.6000	Skip	0.0000
SPIN COLLARS	8"	HI-EFFICIENCY W/ DAMPER	1.00	22.15	22.15	0.5000	0.5000	Skip	0.0000
PREFAB RND PIPE & FITTINGS	8"	26 GA. 90 DEGREE ADJ.	1.00	5.65	5.65	0.4293	0.4293	Skip	0.0000
GRILLES, REGISTERS, DIFFUSERS	10" x8"	GRILLES/REGISTER RIGID HOOK-...	1.00	49.33	49.33	0.8000	0.8000	Skip	0.0000
HANGERS	CL20	CABLE LOCK	8.00	4.75	38.00	Manual	0.0000	Manual	0.0000
HANGERS	#20 Wire ...	STRANDED WIRE ROPE	30.00	0.19	5.70	Manual	0.0000	Manual	0.0000
HANGERS	Unsize	HGR ASSY LABOR	3.00	Skip	0.00	1.0000	0.7500	Skip	0.0000
FAB MATERIAL	26 ga	GALVANIZED	29.12	0.60	17.47	0.0588	1.7123	0.0687	2.0005
COMPONENTS	10# x 3/4"	TEK Screws	40.00	0.03	1.20	0.0056	0.2240	Manual	0.0000
Grand Totals					223.00		6.0156		2.0005

Steve Fradet

From: Mike Graf <mike@g-oinsulation.com>
Sent: Monday, August 21, 2017 11:09 AM
To: Steve Fradet
Subject: BSE POLICE STATION

**BSE POLICE STATION
EXTRA 8" DUCT INSULATION
\$170**

Mike Graf
G & O Insulation
1321 1st Ave. N.
Fargo, ND 58102
Phone: 701-280-9264
Fax: 701-280-2205
E-mail: mike @g-oinsulation.com
Cell # 701-793-1198

Ac-d

IMAGE
Group
Architecture
& Interiors

October 4, 2017



Richard
Moorhead
AIA, NCARB

City of Fargo
Police Department
222 4th Street North
Fargo, North Dakota 58102
Attention: Deputy Chief Anderson

RE: City of Fargo
BSE Police Department Remodeling
Fargo, North Dakota Image 1703

Marcia
Pulczynski
AIA, NCARB,
LEED AP

Dear Deputy Chief Anderson;

Enclosed please find three (3) copies each of AIA Document G701 Change Orders G-1 in the amount of \$2,760.00 and G-2 in the amount of \$9,557.00 for the above referenced project.

225 Fourth
Avenue North
Suite 3
Fargo
North Dakota
58102

If the documents meet with your approval please obtain appropriate signatures and return Architect's and Contractor's copies to this office.

Sincerely,

IMAGE GROUP, INC.

Richard A. Moorhead, NCARB, AIA

403 Center
Avenue
Suite 300
Moorhead
Minnesota
56560

IG: jrg

Enc.

Telephone
218.233.2062

Facsimile
218.233.2575

AIA Document G701™ – 2001

Change Order



PROJECT: <i>(Name and address)</i> City of Fargo BSE Police Department Remodeling Fargo, ND	CHANGE ORDER NUMBER: G-1 DATE: August 7, 2017	OWNER <input type="checkbox"/> ARCHITECT <input type="checkbox"/> CONTRACTOR <input type="checkbox"/> FIELD <input type="checkbox"/> OTHER <input type="checkbox"/>
TO CONTRACTOR: <i>(Name and address)</i> Meinecke-Johnson Company PO Box 2643 Fargo, ND 58108	ARCHITECT'S PROJECT NUMBER: 1703 CONTRACT DATE: May 19, 2017 CONTRACT FOR: General Construction	

The Contract is changed as follows:
(Include, where applicable, any undisputed amount attributable to previously executed Construction Change Directives.)
 Response to Building Inspections Code Review (ASI-G5) ADD \$2,760.00

The original (Contract Sum) XXXXXXXXXXXXXXXXXXXX was	TOTAL ADD \$2,760.00
The net change by previously authorized Change Orders	\$ 522,700.00
The (Contract Sum) XXXXXXXXXXXXXXXXXXXX prior to this Change Order was	\$.00
The (Contract Sum) XXXXXXXXXXXXXXXXXXXX will be (increased) XXXXXXXXXXXX by this Change Order in the amount of	\$ 522,700.00
The new (Contract Sum) XXXXXXXXXXXXXXXXXXXX including this Change Order, will be	\$ 2,760.00
The Contract Time will be INCREASED/DECREASED (unchanged) by zero	\$ 525,460.00
The date of Substantial Completion as of the date of this Change Order, therefore, is unchanged	(0) days.

NOTE: This Change Order does not include changes in the Contract Sum, Contract Time or Guaranteed Maximum Price that have been authorized by Construction Change Directive until the cost and time have been agreed upon by both the Owner and Contractor, in which case a Change Order is executed to supersede the Construction Change Directive.

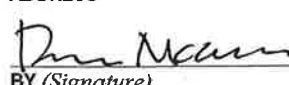
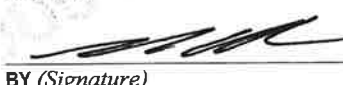
NOT VALID UNTIL SIGNED BY THE ARCHITECT, CONTRACTOR AND OWNER.

<u>Image Group, Inc.</u> ARCHITECT <i>(Firm name)</i> 403 Center Avenue, #300 Moorhead, MN 56560 ADDRESS	<u>Meinecke-Johnson Company</u> CONTRACTOR <i>(Firm name)</i> PO Box 2643 Fargo, ND 58108 ADDRESS	<u>City of Fargo</u> OWNER <i>(Firm name)</i> 200 North 3rd Street Fargo, ND 58102 ADDRESS
 BY <i>(Signature)</i> <u>RICHARD MOORHEAD</u> <i>(Typed name)</i>	 BY <i>(Signature)</i> <u>Roger D. Olson</u> <i>(Typed name)</i>	 BY <i>(Signature)</i> _____ <i>(Typed name)</i>
<u>OCTOBER 4, 2017</u> DATE	<u>October 4, 2017</u> DATE	_____ DATE

CAUTION: You should sign an original AIA Contract Document, on which this text appears in RED. An original assures that changes will not be obscured.



403 Center Avenue / Suite 300 / Moorhead, Minnesota 56560

Architect's Supplemental Instructions

ASI-G1

PROJECT/OWNER: BSE Police Department Remodeling ARCHITECT'S PROJECT NUMBER: 1703
Fargo, North Dakota

TO: Meinecke-Johnson Company CONTRACT FOR: General Construction
3001 First Avenue North
P.O. Box 302
Fargo, ND 58107 DATE: June 12, 2017

The work shall be carried out in accordance with the following supplemental instructions issued in accordance with the Contract Documents. Proceeding with the Work in accordance with these instructions indicates your acknowledgment that there will be no change in the Contract Sum or Contract Time.

DESCRIPTION:

RESPONSE to CODE REVIEW COMMENTS

1. **Second Exit from Room 108.**
 - a. **Provide 3'-0" x 7'-0" Type 'A' Wood Door; Type HM-1 Hollow-Metal Frame; Hardware Group 34.**
 - b. **Refer to attached drawing for location.**

2. **Folding Shower Seat at ADA Shower 101B and 102C**
 - a. **Provide folding shower seat equal to Bobrick Model 9558.**
 - b. **Type 304 stainless steel tubing, wall bracket and piano hinge; 5/16" solid phenolic seat.**
 - c. **Delete scheduled grab bar behind seat.**
 - d. **Refer to attached drawing for location.**

ATTACHMENTS:

Supplemental Drawing S-1 Dated June 12, 2017

ISSUED BY:

A handwritten signature in black ink that reads "Ron Mann".

IMAGE Group Architecture & Interiors

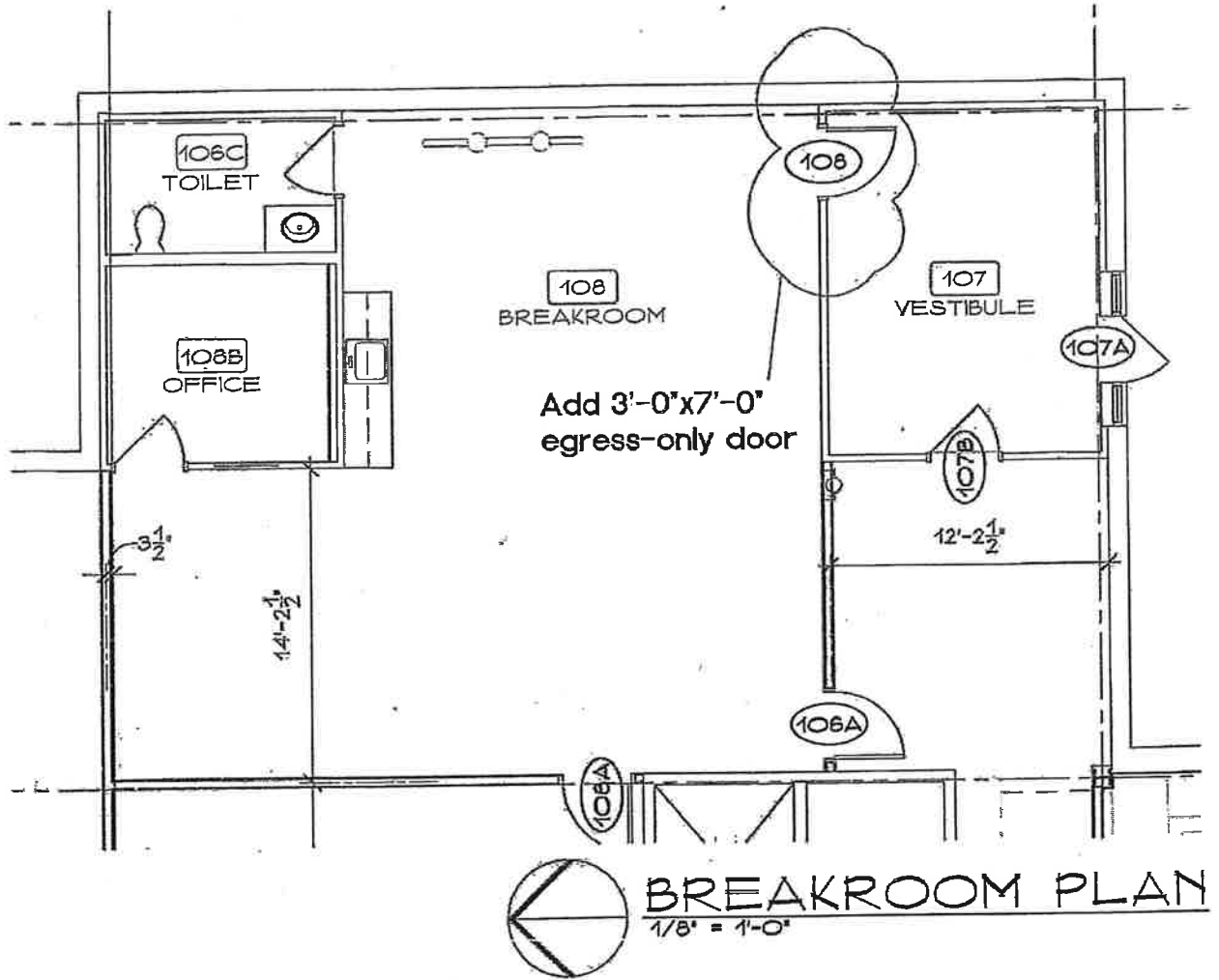

folding shower seat.
Delete adjacent grab
bar.

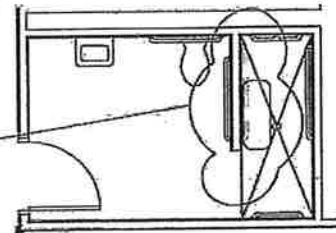

 ADA SHOWER 101B & 102C
1/8" = 1'-0"

MEINECKE - JOHNSON COMPANY

BOX 2643
FARGO, ND 58108

701-293-1040

FAX 701-293-8072

www.meineckejohnsoncompany.com

RANDALL E. JOHNSON, CHAIRMAN
ERIC M. JOHNSON, PRESIDENT
ROGER D. OLSON, SENIOR VICE PRESIDENT
WESLEY D. LEIER, VICE PRESIDENT
BRADY J. HASBARGEN, SECRETARY
KATIE M. HASBARGEN, TREASURER

OFFICE LOCATED AT
5 NORTH FOURTEENTH ST.
FARGO, NORTH DAKOTA 58102

June 26, 2017



Image Group Architects
403 Center Avenue, Suite #300
Moorhead, MN 56560

Attention: Mr. Richard Moorhead

Re: BSE Police Department Remodeling

Dear Richard:

Please find enclosed the following proposal for the BSE Police Department Remodeling project:

ASI-G1:

Add 2nd Exit from Room 108 and two folding shower seats.....\$2,760.00

If this proposal meets with your approval, please issue a change order at your earliest convenience. If you have any questions, don't hesitate to notify our office.

Sincerely,

MEINECKE-JOHNSON COMPANY

Brady Hasbargen
Project Manager

BH:cj

Enclosure

GENERAL CONTRACTOR

CONSTRUCTION MANAGEMENT



CONCRETE CONTRACTOR

MEINECKE-JOHNSON COMPANY

Project 1st Ave. P.D.
 Owner _____
 Location _____
 Architect Frump Group

Sheet No. 15-61
 Estimator [Signature]
 Square Feet _____
 Date 6/20/17

Code	DETAIL	Quantity	Unit Price	Material Cost	Unit Price	Labor Cost	Unit Price	Sub-contract
	<u>Add Door, Frame & Hardware</u>							
	General Conditions			5-		50-		
	Cut in opening			10-		80-		
	Door & Frame			995-		60-		
	Install Hardware			Inc.		80-		
	Grp. Board							No charge
	Paint							250
				1010		270-		250
				76-	LB	114-		
				1086-		384-		250
				384				
				250				
				1720				
				155-				
				113-				
				20-				
				2008				
	<u>Furnish and install Shower Seats</u>							
	General Conditions			5-		25-		
	Backling			14-		28-		
	Shower Seats			495-	20-	40-		
	Grab Bars				15- <	30 >		
				514-		63-		
				39-	LB	27-		
				553-		90-		
				90-				
				643-				
				58-				
				43-				
				8-				
				752-				

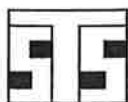

Tri-State Specialties

MAILING ADDRESS: P.O. Box 1184
 Moorhead, MN 56561-1184
PHYSICAL ADDRESS: 3345 Fourth Street East, #2
 West Fargo, ND 58078

T701-540-6758
C701-306-1241
F701-552-7205
E-Mail: joey_tss@yahoo.com

DATE: 5/17/17
TO: All Contractors

ESTIMATE #3748
EXPIRATION DATE: 12/31/17
 (See Terms Below for Conditions of Expiration Date)

BSE POLICE DEPARTMENT REMODELING
FARGO, ND
 We Acknowledge Addendums: 1

Section #101114 – Marker Boards

Base Bid: Includes (1) 8' x 4' Marker Board \$490.00
 Alt. Bid G-1: Delete Above Marker Board (\$490.00)

Section #102600 – Wall Protection

Base Bid: Corner Guards Per Plans & Specs – Architect Verbally
 Approved Construction Specialties as Manufacturer (Must
 be Equal to InPro's Model 160 Series \$439.00
 Alt. Bid G-1: Delete (1) Corner Guard (\$25.00)

Section #102813 – Toilet Accessories

Includes (2) 18" Grab Bars, (2) 36" Grab Bars, (2) 42" Grab Bars, (4) 24"
 Grab Bars, (4) 48" Grab Bars, (9) #59462 Towel Dispensers, (9) #52053
 Soap Dispensers, (9) #56784 Toilet Paper Dispensers, (2) Sanitary
 Napkin Disposals, (2) Rubbermaid Baby Changing Stations
 Above Georgia Pacific Items are being Quoted in the Color "Smoke" \$1,539.00
 Net Cost Add for Adding (2) Shower Seats & Deleting (2) 48" Grab Bars \$495.00

Qualifying Notes:

- 1) Shower Seat (Bradley Model #9558) Listed in ASI-G1 has been Discontinued. Quoting Bradley Model #9591 White Phenolic Shower Seats

Section #104400 – Fire Protection Specialties

Base Bid: Includes (3) Red Fire Extinguisher Cabinets with Extinguisher \$438.00
 Alt. Bid G-1: Delete (1) Fire Extinguisher Cabinet with Extinguisher (\$110.00)

Continued...

Terms: This proposal is subject to the following terms and conditions: (1) Net 30 Days, No Retainage (2) We are a material supply only. Labor and field verification of dimensions & quantities is to be by general contractor. (3) Quote does NOT include sales tax. (4) Quote includes freight (1 shipment to 1 designation) unless otherwise stated. (5) Signature at time of delivery signifies that you received the material in fair and good condition. Any concealed or visible damage must be noted on the Bill of Lading at time of delivery, or the freight carrier will reject your claim. (6) The manufacturer's standard warranty will be apply in all cases. (7) Materials will be delivered as promptly as possible or per your requested delivery date, subject to delays occasioned by fire, accident, labor strikes or any other cause beyond our control. (8) No liquidated damages or backcharges are allowed. (9) Any change which necessitates alterations or extra material not included in our proposal shall be charged for accordingly. (10) In the event you accept this proposal, yet use your own contract form, it is understood that all terms and conditions of this proposal are to be incorporated and made a part thereof. (11) Acceptance of this quote must be made within 30 days to have it price protected through the above stated expiration date. The material must also ship on or before the expiration date. (12) Accounts past due shall bear interest at the rate of 1.5% per month,

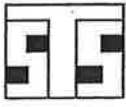

Tri-State Specialties

MAILING ADDRESS: P.O. Box 1184

Moorhead, MN 56561-1184

PHYSICAL ADDRESS: 3345 Fourth Street East, #2
West Fargo, ND 58078

T701-540-6758

C701-306-1241

F701-552-7205

E-Mail: joey_tss@yahoo.com

Section #105613 – Metal Storage Shelving

Unable to Cross-Over Model #'s (C & H Distributors is Out-of-Business)

OPTION #1:

Base Bid #1: Includes (17) Edsal #2924-8CL 36" x 24" x 85" 8 Shelf Closed Commercial Unit, 400 lbs. Capacity Per Shelf – NOTE: Shelving Unit is Complete Stand-Alone Unit – No Add-On Units Available \$4,966.00
Alt. Bid G-1: Delete Shelving Units in Base Bid #1 (\$4,966.00)

OPTION #2:

Base Bid #2: Includes (3) Edsal #UC5350 36" x 24" x 85" 6 Shelf Closed Starter Unit, 750 lbs. Capacity Per Shelf & (14) Edsal #UC5356 36" x 24" x 85" 6 Shelf Closed Add-On Unit, 750 lbs. Capacity Per Shelf \$4,585.00
Alt. Bid G-1: Delete Shelving Units in Base Bid #2 (\$4,585.00)

Section #115213 – Projection Screen

Base Bid: Includes (1) Projection Screen \$2,446.00
Alt. Bid G-1: Delete Above Projection Screen (\$2,446.00)

IMPORTATION:

SALES TAX AND LABOR ARE EXCLUDED IN ALL QUOTE TOTALS U.O.N. (SEE BELOW TERMS).

Terms: This proposal is subject to the following terms and conditions: (1) Net 30 Days, No Retainage (2) We are a material supply only. Labor and field verification of dimensions & quantities is to be by general contractor. (3) Quote does NOT include sales tax. (4) Quote includes freight (1 shipment to 1 designation) unless otherwise stated. (5) Signature at time of delivery signifies that you received the material in fair and good condition. Any concealed or visible damage must be noted on the Bill of Lading at time of delivery, or the freight carrier will reject your claim. (6) The manufacturer's standard warranty will be apply in all cases. (7) Materials will be delivered as promptly as possible or per your requested delivery date, subject to delays occasioned by fire, accident, labor strikes or any other cause beyond our control. (8) No liquidated damages or backcharges are allowed. (9) Any change which necessitates alterations or extra material not included in our proposal shall be charged for accordingly. (10) In the event you accept this proposal, yet use your own contract form, it is understood that all terms and conditions of this proposal are to be incorporated and made a part thereof. (11) Acceptance of this quote must be made within 30 days to have it price protected through the above stated expiration date. The material must also ship on or before the expiration date. (12) Accounts past due shall bear interest at the rate of 1.5% per month,



Change Order Request (1)

TO: MEINECKE JOHNSON
 5 North 14th Street
 Fargo, ND 58108

DATE: June 13, 2017

ATTN: Glenn Moen
Phone: 701-293-1040

TCH CONTRACT NO.:
PROJECT NAME: City of Fargo - BSE Police Department
PROJECT LOCATION: Fargo, ND

Email: bhasbargen@meineckeljohnsoncompany.com

****The lead time for product on this change order is: xxx days upon written acceptance, which is required, to maintain quoted price, otherwise price and/or delivery date will be affected. The acceptance of this change order may or may not cause delays in your project timeline, depending on the type of change involved****

Changes As Requested By Richard Moorhead from Image Group

Door 108 - Add Hm Frame, Wood Door & Hardware

Add \$995.00

Original Contract Amount...	\$35,002.29	Tax Included @ 7.5%
Change Orders Approved to Date...	\$0.00	
Amount This Change Order...	\$995.00	
New Contract Amount...	\$35,997.29	Tax Included @ 7.5%

If you have any questions, please call me direct at 701-566-9101 or email at tdvorak@tchco.com

This Change Order must be signed by a representative of said company & returned to TCH via fax or email before additional material will be shipped or labor performed. This protects both parties and, in most cases, is required by the contract or your home office.

Accepted by _____
(COMPANY NAME)

Signed _____
 Printed Name _____
 Title _____
 Date _____

Respectfully submitted,
TWIN CITY HARDWARE

By Tom Dvorak
 Tom Dvorak

The person signing above acknowledges they are a certified representative of the above listed company with full authority to execute this change order. By signing this change order the above listed company agrees to payment of said Change Order per TCH's credit terms. The person also acknowledges that changes to scope may delay delivery dates as lead times vary based on product availability. All order information, as well as this Change Order Form, must be given to Twin City Hardware with enough time to adhere to lead time requirements, order entry time, shipping time, and workload. Failure to do so absolves Twin City Hardware of any additional costs incurred due to shipment delays. By accepting this correspondence of change, the person also accepts all terms noted on this form, or on any form related to this change, including form of said company accepting the change.

BSE Police Department Remodel
Fargo, North Dakota
Request For Information

FROM: Meinecke-Johnson Co.
P.O. Box 2643
5 North 14th Street
Fargo, ND 58108
Ph. (701) 293-1040
Fax (701) 293-8072

RFI NUMBER: 001
ISSUE DATE: 06/28/17
RESPONSE BY: _____

TO: Image Group Architecture & Interiors
403 Center Avenue
Moorhead, MN 56560

REF: _____

SPEC SECTION: 093113

ATTENTION: Richard Moorhead

Waterproofing

INFORMATION REQUESTED: The specifications do not call for waterproofing behind the tile in the showers. Is this something we would like to address to ensure the showers are waterproofed? Pleased advise.

cc: _____

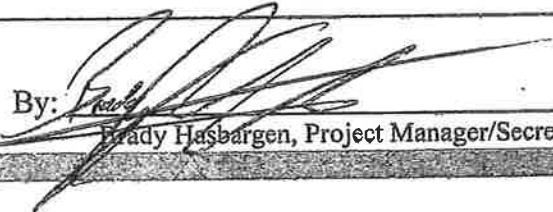
By: 
Brady Hasbargen, Project Manager/Secretary

REPLY: _____

Provide liquid waterproof membrane applied to cement board in accordance with specified recommendations of the Tile Council of North America (TCNA).

See attached.

Richard Moorhead

June 28, 2017

ATTACHMENTS: _____

By: _____

cc: _____

Date: _____

SHOWER RECEPTORS

**Wood or Metal Studs
Cement Backer Board or
Fiber Cement Backer Board Walls
Mortar Bed Floor
Ceramic Tile**

B415-12

Recommended Uses

- For showers that do not have prefabricated receptors.
- Environmental Classifications**
- With cementitious or epoxy bond coat—Res1, 2, 3, 5; Com1, 2, 3, 5.
- With organic adhesive bond coat—Res1, 2, 3; Com1, 2.
- For Res4 and Com4, see SR614.
- For installations that may be exposed to staining, specify tile and grout suitable for exposure. Consult product manufacturers; see also Product Selection Guides.
- For installations that may be exposed to mild chemical attack, specify epoxy grout and tile suitable for exposure. For greater resistance to chemical exposure, also specify an epoxy bonding material. Consult product manufacturers; see also Product Selection Guides.

Limitations

- Maximum stud spacing 16" on center.
- When organic adhesive is used—not for areas exposed to temperatures exceeding 140°F.
- When organic adhesive is used—maximum tile size 8" x 8" unless organic adhesive manufacturer allows larger tile size. See Notes.
- Organic adhesive may be used on walls only; do not use on floor or curb.

Membrane Options

- A waterproof membrane (A118.10) or vapor retarder membrane (A108.02-3.8) must be specified for walls to prevent moisture intrusion and protect adjacent building materials. Specifier shall indicate if complete waterproofing of walls is required, including treatment at termination points.
- Check with membrane manufacturer for suitability for applicable conditions, as not all membranes are suitable for steam, high-temperature and/or chemical exposure, or exterior use.
- When glass tile is used, consult glass tile manufacturer for membrane options and recommendations.

Requirements

- Wood studs—dry and well-braced, minimum depth 3-1/2"
- Metal studs—well-braced; 20 gauge (0.033") or heavier; minimum depth 3-1/2" for residential applications or 3-5/8" for commercial applications.
- Surface of units—clean and free of dirt, dust, paint, and oily film.
- Membrane behind backer board, when used, must lap over shower pan membrane.
- Slope shower pan membrane 1/4" per foot to weep holes in drain.
- Turn shower pan membrane up walls a minimum of 3" above shower curb (6" above floor in showers without curbs).
- Fur out studs above shower pan membrane or notch-out studs behind the shower pan membrane so folds/corners of shower pan membrane do not cause backer board to bow inward, or use Alternate Receptor Base Method.
- Surround drain with pea gravel or other weep protection to prevent mortar from blocking weep holes.

Preparation by Backer Board Installers

- Maximum allowable variation in the tile substrate—for tiles with all edges shorter than 15", maximum allowable

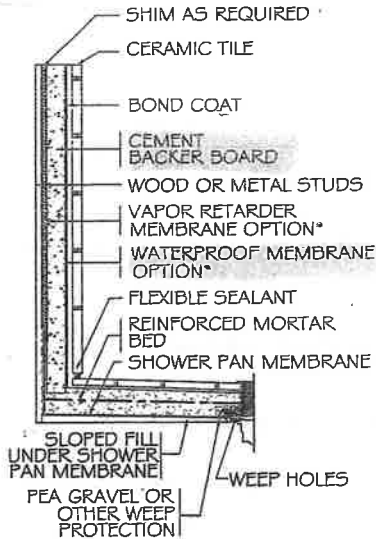

*USE OF A MEMBRANE ON WALLS IS REQUIRED. SEE MEMBRANE OPTIONS.
SHOWER RECEPTORS, CURBS, SEATS, ETC., MUST BE PROPERLY WATERPROOFED AND INSTALLED TO AVOID WATER DAMAGE TO ADJACENT BUILDING MATERIALS. SEE COMMON SHOWER CONFIGURATIONS SECTION.

With cement backer board. ▲

With fiber-cement backer board. ▼

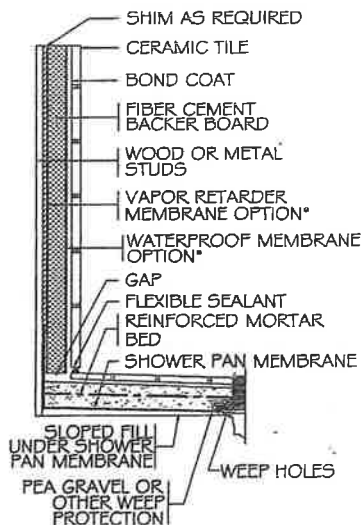

*USE OF A MEMBRANE ON WALLS IS REQUIRED. SEE MEMBRANE OPTIONS.
SHOWER RECEPTORS, CURBS, SEATS, ETC., MUST BE PROPERLY WATERPROOFED AND INSTALLED TO AVOID WATER DAMAGE TO ADJACENT BUILDING MATERIALS. SEE COMMON SHOWER CONFIGURATIONS SECTION.

MEINECKE - JOHNSON COMPANY

BOX 2643
FARGO, ND 58108

701-293-1040
FAX 701-293-8072

www.mjco.us

RANDALL E. JOHNSON, PRESIDENT/CHAIRMAN
DENNIS A. OLSON, VICE CHAIRMAN/SECRETARY
ROGER D. OLSON, SENIOR VICE PRESIDENT
ERIC M. JOHNSON, VICE PRESIDENT
KATIE M. HASBARGEN, TREASURER

OFFICE LOCATED AT
5 NORTH FOURTEENTH ST.
FARGO, NORTH DAKOTA 58102

August 10, 2017



Image Group Architects
403 Center Avenue, Suite #300
Moorhead, MN 56560

Attention: Mr. Richard Moorhead

Re: BSE Police Department Remodeling

Dear Richard:

To provide liquid waterproof membrane per the response to RFI 001 for nine thousand hundred fifty seven dollars & no/100 (\$9,557.00) as per the attached breakdown.

If this proposal meets with your approval, please issue a change order at your earliest convenience. If you have any questions, don't hesitate to notify our office.

Sincerely,

MEINECKE-JOHNSON COMPANY

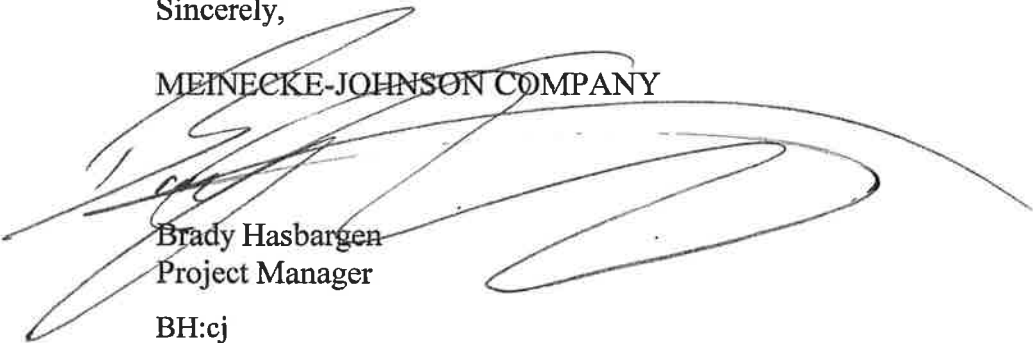

Brady Hasbargen
Project Manager

BH:cj

Enclosure

GENERAL CONTRACTOR

CONSTRUCTION MANAGEMENT



CONCRETE CONTRACTOR

I'LL TILE & STONE, INC.

June 28th, 2017

Change Order Proposal

Job: BSE Police .
To: Meinecke-Johnson

I'll Tile & Stone, Inc. proposes a change order to add waterproofing membrane, liquid applied, to all shower stalls, including all walls and floors, to ensure warranty and waterproof units.

<u>Base Material ADD</u>	<u>\$4,410.00</u>
<u>Base Labor ADD</u>	<u>\$3,780.00</u>
<u>Base Bid ADD</u>	<u>\$8,190.00</u>

Note: Material to be used is Laticrete HydroBarrier.

Paul Schiller
Estimator / PM

1673 Dan Street
Detroit Lakes, MN
56501

PHONE (218) 847-0335
FAX (218) 847-0544
E-MAIL illtileandstone@yahoo.com



**PUBLIC WORKS
OPERATIONS**

15

Fleet Management, Forestry,
Streets & Sewers,
Watermains & Hydrants
402 23rd STREET NORTH
FARGO, NORTH DAKOTA 58102
PHONE: (701) 241-1453
FAX: (701) 241-8100

October 17, 2017

The Honorable Board of City Commissioners
City of Fargo
Fargo, ND 58102

RE: Sidewalk Snow and Ice Removal Code Enforcement

Commissioners:

Proposals were opened on Thursday, September 28, 2017, in response to a Request for Proposal (RFP) issued by Public Works for "Sidewalk Snow and Ice Removal Code Enforcement". A total of four (3) sealed responses were received.

A proposal selection committee made up of Mark Williams (Public Works Services Manager), Melissa Wolf (Public Works Administrative Services Manager), and myself have reviewed the proposals received and evaluated them on the following criteria:

- Past Work Experience,
- Available Resources,
- Proposed Fees (Attached Bid Tab).

Based on the review of the stated criteria, the committee is recommending award of the 2017/2018 sidewalk snow and ice removal code enforcement contract to Style-it-Services.

RECOMMENDED MOTION: I/we hereby move based on the request for proposal (RFP17285) to award Style-it-Services the 2017/2018 sidewalk snow and ice removal code enforcement contract.

Respectfully submitted,

Ben Dow
Director of Operations
Fargo Public Works

Sidewalk Snow and Ice Removal Code Enforcement RFP

Fargo Public Works - 2017/2018

<i>Hourly Services</i>	All-Terrain	Style-it-Services	Polar Snow & Ice
Skid Steer Front Loader with Bucket and Operator	\$85.00	\$75.00	\$95.00
Skid Steer Front Loader with Snow Blower and Operator	\$85.00	\$75.00	\$95.00
Toolcat Utility Machine with Bucket and Operator	\$100.00	\$75.00	NA
Toolcat Utility Machine with Bucket and Operator	\$100.00	\$75.00	NA
Toolcat Utility Machine with Snow Blower and Operator	\$75.00	\$75.00	\$85.00
Walk Behind Snow Blower and Operator	\$75.00	\$75.00	\$85.00
<i>Fee Per Pound</i>	All-Terrain	Style-it-Services	Polar Snow & Ice
Sidewalk Ice Melt	\$0.70	\$0.50	\$1.00



**PUBLIC WORKS
OPERATIONS**

116

Fleet Management, Forestry,
Streets & Sewers,
Watermains & Hydrants
402 23rd STREET NORTH
FARGO, NORTH DAKOTA 58102
PHONE: (701) 241-1453
FAX: (701) 241-8100

October 17, 2017

The Honorable Board of City Commissioners
City of Fargo
Fargo, ND 58102

RE: Sidewalk Snow and Ice Removal City Owned Properties

Commissioners:

Proposals were opened on Thursday, September 28, 2017, in response to a Request for Proposal (RFP) issued by Public Works for "Sidewalk Snow and Ice Removal City Owned Properties". A total of four (6) sealed responses were received.

A proposal selection committee made up of Mark Williams (Public Works Services Manager), Melissa Wolf (Public Works Administrative Services Manager), and myself have reviewed the proposals received and evaluated them on the following criteria:

- Past Work Experience,
- Available Resources,
- Proposed Fees (Attached Bid Tab).

Based on the review of the stated criteria, the committee is recommending award of the 2017/2018 sidewalk snow and ice removal services contract to Polar Snow & Ice.

RECOMMENDED MOTION: I/we hereby move based on the request for proposal (RFP17285) to award Polar Snow & Ice the 2017/2018 sidewalk snow and ice removal city owned properties.

Respectfully submitted,

Ben Dow
Director of Operations
Fargo Public Works

2017-2018 Contracted Sidewalks Bid Tab

Location	CuFe		Meyer Services		Style-It Services		Polar Snow & Ice		All-Terrain		Baker Snow & Ice	
	Snow Removal \$ Amount	Chemical Application \$ Amount	Snow Removal \$ Amount	Chemical Application \$ Amount	Snow Removal \$ Amount	Chemical Application \$ Amount	Snow Removal \$ Amount	Chemical Application \$ Amount	Snow Removal \$ Amount	Chemical Application \$ Amount	Snow Removal \$ Amount	Chemical Application \$ Amount
Flood Lots	\$1,504.00	\$1,152.00	\$1,312.00	\$1,705.00	\$1,377.60	\$1,312.00	\$1,230.00	\$1,312.00	\$1,623.60	\$1,886.00	\$2,980.00	\$82.00

All sidewalks are four and a half feet in width.

October 18, 2017

Honorable Board of City
Commissioners
City of Fargo
Fargo, ND

Re: Project No. FP-17-A1

Dear Commissioners:

Bids were opened at 11:30 AM on Wednesday, October 18, 2017, for Regional Detention Pond & Storm Sewer Collection System, Project No. FP-17-A1, located at SW ¼ of I-94/I-29 Interchange.

The bids were as follows:

Gladen Construction Inc.	\$271,839.00
Ryan Contracting	\$293,601.00
Dirt Dynamics	\$304,137.70
Dakota Underground Co.	\$352,270.00
Master Construction Co., Inc.	\$374,920.00
Sellin Brothers, Inc.	\$389,547.50
Central Specialties, Inc.	\$392,428.55
Veit & Company, Inc.	\$619,750.00

Engineer's Estimate \$461,290.00

The special assessment escrow is not required.

This office recommends award of the contract to Gladen Construction Inc. in the amount of \$271,839.00 as the lowest and best bid.

Sincerely,

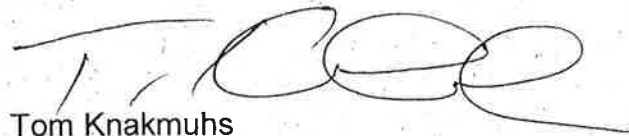

Tom Knakmuhs
Division Engineer

TAK/klo



ENGINEER'S STATEMENT OF ESTIMATED COST

PROJECT # FP-17-A1

Regional Detention Pond & Storm Water Collection System

SW 1/4 of I-94/I-29 interchange

WHEREAS, bids have been opened and filed for the above described Project for City of Fargo, North Dakota; and WHEREAS, an estimate of the cost of work is required by the engineer for the City of Fargo, North Dakota;

NOW THEREFORE Tom Knakmuhs, do hereby certify as follows:

That I am the Division Engineer for the City of Fargo, North Dakota;

That the following is detailed statement of the estimated cost of the job described as:

Regional Detention Pond & Storm Water Collection System Project # FP-17-A1 of the City of Fargo, North Dakota.

Line Description	Unit	Quantity	Unit Price (\$)	Amount (\$)
Miscellaneous				
1 Mobilization	LS	1.00	7,500.00	7,500.00
2 Site Grading	SY	25,000.00	0.40	10,000.00
3 Topsoil - Spread	CY	3,000.00	2.80	8,400.00
4 Seeding Type B	SY	25,000.00	0.30	7,500.00
5 Mulching Type 1 - Hydro	SY	25,000.00	0.35	8,750.00
6 Traffic Control - Minor	LS	1.00	750.00	750.00
7 F&I Driveway 6" Thick Reinf Conc	SY	320.00	63.00	20,160.00
8 F&I Decid Tree 1.5" Dia	EA	18.00	300.00	5,400.00
9 F&I Decid Tree 3" Dia	EA	19.00	525.00	9,975.00
			Miscellaneous Total	78,435.00
Storm Sewer				
10 Connect Pipe to Exist Structure	EA	2.00	2,500.00	5,000.00
11 F&I Pipe 15" Dia Reinf Conc	LF	285.00	49.50	14,107.50
12 F&I Pipe 24" Dia Reinf Conc	LF	40.00	78.50	3,140.00
13 F&I Flared End Section 24" Dia Reinf Conc	EA	1.00	725.00	725.00
14 F&I Pipe 48" Dia Reinf Conc	LF	815.00	124.50	101,467.50
15 F&I Flared End Section 48" Dia Reinf Conc	EA	1.00	1,625.00	1,625.00
16 F&I Tee Manhole 48"x48" Reinf Conc	EA	3.00	3,900.00	11,700.00
17 F&I Manhole 5' Dia Reinf Conc	EA	1.00	3,710.00	3,710.00
18 F&I Manhole 7' Dia Reinf Conc	EA	2.00	9,915.00	19,830.00
19 F&I Outlet Structure	EA	1.00	11,500.00	11,500.00
20 F&I Trash Guard	EA	2.00	1,317.00	2,634.00
			Storm Sewer Total	175,439.00
Erosion & Sediment Control				
21 Stormwater Management	LS	1.00	1,000.00	1,000.00
22 Sediment Control Log 6" to 8" Dia	LF	30.00	3.50	105.00
23 Inlet Protection - Existing Inlet	EA	13.00	150.00	1,950.00
24 Inlet Protection - New Inlet	EA	5.00	125.00	625.00
25 Temp Construction Entrance	EA	1.00	3,000.00	3,000.00
26 F&I Splash Pad 9" Thick Reinf Conc	SY	20.00	198.00	3,960.00
27 F&I Rip Rap Rock	CY	25.00	125.00	3,125.00
28 Silt Fence - Standard	LF	2,100.00	2.00	4,200.00
			Erosion & Sediment Control Total	17,965.00
			Total Construction in \$	271,839.00
			Engineering	11.00 %
			Legal & Misc	7.00 %
			Contingencies	10.00 %
			Administration	6.00 %
			Interest	4.00 %
			Total Estimated Costs	375,137.82



ENGINEER'S STATEMENT OF ESTIMATED COST
PROJECT # FP-17-A1
Regional Detention Pond & Storm Water Collection System

General Infrastructure Funds - 401	375,137.82
Unfunded Costs	0.00

IN WITNESS THEREOF, I have hereunto set my hand and seal

Date: 10/18/2017

A handwritten signature in black ink, appearing to read "Tom Knakmuhs", written over a horizontal line.

Tom Knakmuhs
Division Engineer



(18)

PUBLIC WORKS PROJECTS EVALUATION COMMITTEE

Project No. FM-17-A1

Type: Final Balancing Change Order #2

Location: Southwood Drive

Date of Hearing: 10/16/17

Routing	Date
City Commission	10/23/2017
PWPEC File	X
Project File	Roger Kluck

The Committee reviewed the accompanying correspondence from Project Manager, Roger Kluck, for Final Balancing Change Order #2 in the amount of \$4,108.73 bringing the total contract amount to \$114,198.96.

Staff is recommending approval of Final Balancing Change Order #2.

On a motion by Mark Bittner, seconded by Ben Dow, the Committee voted to recommend approval of Final Balancing Change Order #2.

RECOMMENDED MOTION

Approve Final Balancing Change Order #2 in the amount of \$4,108.73 to Excavating, Inc.

PROJECT FINANCING INFORMATION:

Recommended source of funding for project:	Yes	No
Flood Sales Tax Funds		
Developer meets City policy for payment of delinquent specials		N/A
Agreement for payment of specials required of developer		N/A
Letter of Credit required (per policy approved 5-28-13)		N/A

COMMITTEE

- Tim Mahoney, Mayor
- Jim Gilmour, Director of Planning
- Steve Dirksen, Fire Chief
- Mark Bittner, Director of Engineering
- Bruce Grubb, City Administrator
- Ben Dow, Director of Operations
- Steve Sprague, City Auditor
- City Engineer
- Kent Costin, Finance Director

Present	Yes	No	Unanimous
			<input checked="" type="checkbox"/>
<input type="checkbox"/>	<input type="checkbox"/>	<input type="checkbox"/>	
<input checked="" type="checkbox"/>	<input checked="" type="checkbox"/>	<input type="checkbox"/>	
<input checked="" type="checkbox"/>	<input checked="" type="checkbox"/>	<input type="checkbox"/>	Ryan Erickson
<input checked="" type="checkbox"/>	<input checked="" type="checkbox"/>	<input type="checkbox"/>	
<input checked="" type="checkbox"/>	<input checked="" type="checkbox"/>	<input type="checkbox"/>	
<input checked="" type="checkbox"/>	<input checked="" type="checkbox"/>	<input type="checkbox"/>	
<input checked="" type="checkbox"/>	<input checked="" type="checkbox"/>	<input type="checkbox"/>	Brenda Derrig
<input type="checkbox"/>	<input type="checkbox"/>	<input type="checkbox"/>	

ATTEST:

B. E. Derrig
Brenda E. Derrig, P.E.
Division Engineer

C: Kristi Olson



CITY OF FARGO
ENGINEERING DEPARTMENT
CHANGE ORDER REPORT

Project No: FM-17-A1 Change Order No: 2
 Project Name: House Demo, New Levee, and Incidentals
 Date Entered: 9/29/2017 For: Excavating, Inc

This change is made under the terms of or is supplemental to your present contract, if and when approved, you are ordered to perform the work in accordance with the additions, changes, or alterations hereinafter described.

EXPLANATION OF CHANGE: Final Balancing change order

This change order reconciles the estimated quantities used in the contract with the final quantities as measured in the field.

Section	Line No	Item Description	Unit	Orig Cont Qty	Prev C/O Qty	Prev Cont Qty	Curr C/O Qty	Tot Cont Qty	Unit Price (\$)	C/O Ext Price (\$)
Removals	6	Remove Tree	EA	2.00	0.00	2.00	1.00	3.00	125.00	125.00
	10	Remove Curb & Gutter	LF	776.00	0.00	776.00	10.00	786.00	3.00	30.00
Removals Sub Total (\$)										155.00
Sanitary Sewer	12	Remove Pipe All Sizes All Types	LF	193.00	0.00	193.00	-20.00	173.00	7.90	-158.00
Sanitary Sewer Sub Total (\$)										-158.00
Watermain	23	F&I Hydrant Ext. 12" High	EA	1.00	0.00	1.00	-1.00	0.00	350.00	-350.00
Storm Sewer	25	Remove Pipe All Sizes All Types	LF	24.00	0.00	24.00	37.00	61.00	7.90	292.30
Watermain Sub Total (\$)										-350.00
Storm Sewer Sub Total (\$)										292.30
Paving	26	F&I Curb & Gutter Standard (Type II)	LF	130.00	0.00	130.00	10.00	140.00	55.00	550.00
Paving Sub Total (\$)										550.00
Erosion & Sediment control	28	Inlet Protection - Existing Inlet	EA	2.00	0.00	2.00	-1.00	1.00	131.25	-131.25
	29	Silt Fence - Heavy Duty	LF	100.00	0.00	100.00	94.00	194.00	2.10	197.40
Erosion & Sediment control Sub Total (\$)										66.15
flood mitigation	30	Inspection Trench	CY	533.00	0.00	533.00	-50.00	483.00	5.50	-275.00
flood mitigation Sub Total (\$)										-275.00
site restoration	32	Topsoil - Import	CY	171.00	0.00	171.00	524.00	695.00	11.00	5,764.00
	34	Casting to Grade - Blvd	EA	1.00	0.00	1.00	-1.00	0.00	350.00	-350.00



CITY OF FARGO
ENGINEERING DEPARTMENT
CHANGE ORDER REPORT

site restoration	35	Seeding Type B	SY	4,500.00	0.00	7,404.22	11,904.22	0.19	1,406.80
	36	Mulching Type 1 - Hydro	SY	4,500.00	0.00	7,404.22	11,904.22	0.35	2,591.48
							site restoration Sub Total (\$)		9,412.28
Site #1 606	40	Fill - Contractor Supply	CY	900.00	0.00	-568.00	332.00	10.00	-5,680.00
Southwood	42	Excavation	CY	250.00	0.00	32.00	282.00	3.00	96.00
							Site #1 606 Southwood Sub Total (\$)		-5,584.00
Summary									
Source Of Funding									
Net Amount Change Order # 2 (\$)									
Previous Change Orders (\$)									
Original Contract Amount (\$)									
Total Contract Amount (\$)									

4,108.73
0.00
110,090.23
114,198.96

I hereby accept this order both as to work to be performed and prices on which payment shall be based.

CONTRACT TIME	Current Completion Date	Additional Days	New Completion Date
	08/29/2017	0.00	08/29/2017
APPROVED	APPROVED DATE		
For Contractor	Department Head		
Title	Mayor		
	Attest		

[Signature]
ESTIMATOR

[Signature]
10/17/17

REPORT OF ACTION

19

PUBLIC WORKS PROJECTS EVALUATION COMMITTEE

Type: Encroachment Agreement

Location: 1002 10th St S

Date of Hearing: 10/16/2017

<u>Routing</u>	<u>Date</u>
City Commission	<u>10/23/2017</u>
PWPEC File	<u>X</u>
Project File	<u>Brenda Derrig</u>
	<u>Kristy Schmidt</u>

Salem Evangelical Free Church has submitted a site plan to reconstruct their parking lot. Their existing parking lot encroaches into the City Right-of-Way. They wish to reconstruct their parking lot in the same location and continue to encroach. They are also asking to waive the \$500 annual fee.

Planning staff has reviewed the application and notes that coming into compliance with the Land Development Code with parking and parking lot buffer is difficult to achieve due to site constraints. If PWPEC were to approve an encroachment agreement, the parking lot buffer is not waived; the property would be non-compliant with the LDC.

Planning staff would like the opportunity to work with the applicant to provide plantings in the right-of-way to beautify the streetscape and screen the parking lot, which would be maintained privately. This is not a condition to meet the parking lot buffer requirement.

Staff is recommending approval provided the Salem Evangelical agree to the following terms:

- Planning to work with applicate to provide plantings in the right-of-way.
- Hold the City harmless against any and all expenses, demands, claims or losses sustained by the City by use of the public right of way by the encroacher.
- Will be responsible for paying all costs above and beyond those the City would have incurred to return the area to a vegetated surface in association with future improvement districts.
- Application fee for the encroachment in the amount of \$500.
- Agreement expires upon sale or transfer of the property.

On a motion by Kent Costin, seconded by Steve Sprague, the Committee voted to recommend approval of the encroachment agreement and to waive the annual fee subject to the terms above.

RECOMMENDED MOTION

Concur with the recommendations of PWPEC and approve the encroachment agreement waiving the annual fee.

PROJECT FINANCING INFORMATION:

Recommended source of funding for project: N/A

Developer meets City policy for payment of delinquent specials
Agreement for payment of specials required of developer
Letter of Credit required (per policy approved 5-28-13)

	<u>Yes</u>	<u>No</u>
	<u>N/A</u>	<u> </u>
	<u>N/A</u>	<u> </u>
	<u>N/A</u>	<u> </u>

PWPEC ROA
10/16/17 -- Page 2

COMMITTEE

Tim Mahoney, Mayor
Jim Gilmour, Director of Planning
Steve Dirksen, Fire Chief
Mark Bittner, Director of Engineering
Bruce Grubb, City Administrator
Ben Dow, Director of Operations
Steve Sprague, City Auditor
City Engineer
Kent Costin, Finance Director

Present	Yes	No	Unanimous
<input checked="" type="checkbox"/>	<input checked="" type="checkbox"/>	<input type="checkbox"/>	<input checked="" type="checkbox"/>
<input checked="" type="checkbox"/>	<input checked="" type="checkbox"/>	<input type="checkbox"/>	
<input checked="" type="checkbox"/>	<input checked="" type="checkbox"/>	<input type="checkbox"/>	Ryan Erickson
<input checked="" type="checkbox"/>	<input checked="" type="checkbox"/>	<input type="checkbox"/>	
<input checked="" type="checkbox"/>	<input checked="" type="checkbox"/>	<input type="checkbox"/>	
<input checked="" type="checkbox"/>	<input checked="" type="checkbox"/>	<input type="checkbox"/>	
<input checked="" type="checkbox"/>	<input checked="" type="checkbox"/>	<input type="checkbox"/>	Brenda Derrig
<input checked="" type="checkbox"/>	<input checked="" type="checkbox"/>	<input type="checkbox"/>	

ATTEST:

C: Kristi Olson

Brenda E. Derrig, P.E.
Division Engineer



Memorandum

To: Members of PWPEC
From: Kristy Schmidt, Project Engineer *KLS*
CC: Curt Skarphol, Houston Engineering
Date: October 12, 2017
Re: Salem Evangelical Free Church -1002 10th St S

Salem Evangelical Free Church has submitted a site plan to reconstruct their parking lot. Their existing parking lot encroaches into the City Right-of-Way. They wish to reconstruct their parking lot in the same location and continue to encroach. They are also asking to waive the \$500 annual fee.

Planning staff has reviewed the application and notes that coming into compliance with the Land Development Code with parking and parking lot buffer is difficult to achieve due to site constraints. If PWPEC were to approve an encroachment agreement, the parking lot buffer is not waived; the property would be non-compliant with the LDC.

Planning staff would like the opportunity to work with the applicant to provide plantings in the right-of-way to beautify the streetscape and screen the parking lot, which would be maintained privately. This is not a condition to meet the parking lot buffer requirement.

Staff is recommending to formalize this encroachment with the following stipulation:

- Planning to work with applicate to provide plantings in the right-of-way.
- Hold the City harmless against any and all expenses, demands, claims or losses sustained by the City by use of the public right of way by the encroacher.
- Will be responsible for paying all costs above and beyond those the City would have incurred to return the area to a vegetated surface in association with future improvement districts.
- Application fee for the encroachment in the amount of \$500.
- Minimum annual fee of \$500
- Agreement expires upon sale or transfer of the property.

Recommended Motion:

Approve the encroachment at 1002 10th St S contingent upon the owner to meet the above criteria.

Attachment

10 AVE S

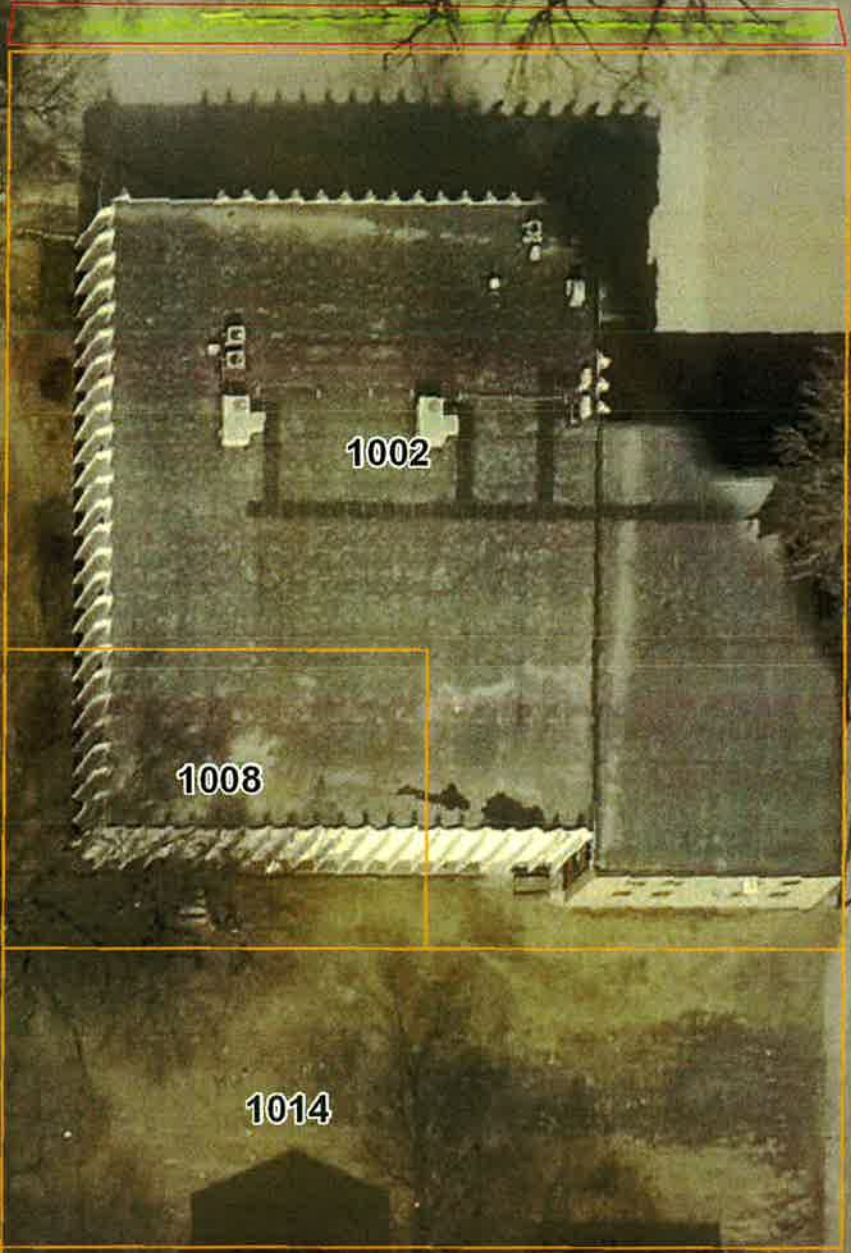

City of Fargo, ND

These data are provided on an "AS-IS" basis, without warranty of any type, expressed or implied, including but not limited to any warranty as to their performance, merchantability, or fitness for any particular purpose.

1002 10th St S

1:564

10/12/2017 11:21:01 AM

This map is not a substitute for accurate field surveys or for locating actual property lines and any adjacent features.



Kristy Schmidt

From: Curt Skarphol <cskarp@houstoneng.com>
Sent: Wednesday, September 13, 2017 3:19 PM
To: Kristy Schmidt
Cc: Vines, John
Subject: Salem Evangelical Free Church - Encroachment Easement Request
Attachments: Encroach_Agree_SalemEFree_8-13-17.pdf;
Salem_E_Free_Encroachment_Description.docx

CAUTION: This email originated from an outside source. Do not click links or open attachments unless you know they are safe.

Hi Kristy,

As per our discussions in the past few days, Salem Evangelical Free Church at 1002 10th Street South in Fargo, has an existing parking lot and sidewalk on the north side of the building that is in very tough shape and is in need of replacement. This is in the area lying west of the alley. Most of the existing pavement is concrete, with a small portion next to the alley in asphalt.

Our survey of the existing conditions shows that the existing concrete parking lot extends roughly 6.5 feet into the public right-of-way of 10th Avenue South. These existing improvements were built that way around 40 years ago. To replace the pavement in this area and retain the existing parking spaces requires that the reconstructed pavement be replaced in the same location as it is situated currently. Without the existing encroachment, the church would lose 5 of its 28 off street parking stalls. Without the encroachment, there would only be space for 3 parallel parking stalls in the encroachment area where there is currently space for 8 cars.

As the church has such a limited number of existing off-street parking spaces, it is critical that the church not lose any of these spaces. Already the neighborhood is sensitive to the on-street parking demands of the church, and to put even an extra 5 cars out into the street, would likely cause issues with the neighborhood. Also, these parking stalls in the encroachment area are among the closest to the building entries, so are often used by the elderly or families with small children. This is especially important in the winter, when due to the snow piled along the street curbs, it becomes difficult to get in and out of the passenger side of a car parked along the street curb.

With that, Salem Church would like to request an encroachment easement from the City of Fargo to allow a 6.0-foot wide encroachment into the right-of-way along the north line of Lot 14, to allow for the replacement of the existing pavement with new pavement in the same location. Salem Church agrees to pay the \$500 application fee, and to provide a Certificate of Insurance for the encroachment area. Also, Salem Church would like to request consideration for a waiver of the \$500 annual fee that would be charged for the easement.

I've attached the encroachment easement drawing and the Microsoft Word file with the legal description to this e-mail. They are the same as the ones I sent you this morning.

Let me know if you need anything else.

Thanks!

Curt

Curt Skarphol

PE (ND) / PLS (ND, MN, SD) / CFeds / CFM

Principal / Project Manager

Office 701.237.5065

Direct 701.499.2075

Cell 701.412.3242



Houston Engineering, Inc.

1401 21st Ave N. • Fargo, ND • 58102

www.houstoneng.com

This entire message (including all forwards and replies) and any attachments are for the sole use of the intended recipient(s) and may contain proprietary, confidential, trade secret, work-product, attorney-client or privileged information. Any unauthorized review, use, disclosure or distribution is prohibited and may be a violation of law. If you are not the intended recipient, please contact the sender by reply email and destroy all copies of the original message.

ENCROACHMENT AGREEMENT

THIS AGREEMENT, made and entered by and between the **CITY OF FARGO**, a North Dakota municipal corporation, hereinafter referred to as "City", and **SALEM EVANGELICAL FREE CHURCH**, hereinafter referred to as "Salem" or "Owner",

WITNESSETH:

WHEREAS, Salem desires to encroach on a portion of City right-of-way (described below) for continued use as a parking lot; and

WHEREAS, Salem has requested permission to encroach on a portion of the right-of-way hereinafter particularly described, thus allowing it to utilize City rights-of-way for such purpose;

WHEREAS, Salem has agreed to execute this agreement required by City for encroachment on City right-of-way;

NOW, THEREFORE, it is hereby agreed by and between the parties hereto as follows:

1. Salem, its successors and assigns, is hereby granted the right to encroach and use a portion of the right-of-way, said encroachment being for the continued use of a parking lot, located as follows:

That part of the right-of-way of 10th Avenue South lying adjacent to Block BB,

Erskine's Addition to the City of Fargo, Cass County, North Dakota, described as follows: A 6.00-foot wide strip of land lying northerly of and being coincident with the following described line: BEGINNING at the northeast corner of Lot 14, said Block BB; thence South 87°45'39" West (assumed bearing), along the northerly line of said Lot 14, for a distance of 140.00 feet to the northwest corner of said Lot 14, and there terminating said line.

Said encroachment is more particularly described and indicated in attached Exhibit "A" showing the property involved and the location of the parking lot. Exhibit "A" is attached hereto and incorporated herein by reference.

2. It is the intent of this agreement that Owner may utilize City right-of-way for the purpose of a parking lot.

3. Owner, its successors and assigns will, during any use of said public right-of-way, use due care to protect city streets, utilities and all other public property, minimize disruption to pedestrian travel in accordance with MUTCD Standards and Specifications; and that upon discontinuance of use, Owner will restore and replace all public property to its vegetated surface, or pay all costs above those that would be incurred by City to restore such surface.

4. It is understood and agreed by and between the parties that Owner, its successors and assigns, will be responsible for the repair or replacement of any public property which may be damaged or destroyed as a direct or indirect result of the use of the public rights-of-way for a parking lot. Owner agrees to accept all maintenance responsibility for the parking lot.

5. Owner, its successors and assigns, agrees to further hold the City harmless against any and all expenses, demands, claims or losses of any kind that may be sustained by City, its officers, agents and employees, its property, streets, sidewalks, or any other municipal improvements by reason of the use of the public rights-of-way as aforesaid. Owner agrees to provide to the City a certificate of insurance indicating acceptance by its insurer of its obligation to defend and hold the City harmless as hereinabove stated.

6. This agreement is personal to Owner and cannot be sold, transferred or otherwise assigned. This agreement shall immediately terminate upon Owner's sale, transfer or assignment of the encroaching property. Subsequent owners may request permission to encroach, and enter into a separate agreement with City. City shall not withhold permission to encroach under the terms herein without due cause.

7. It is understood and agreed by and between the parties that this agreement and permission to encroach is given subject to any limitation on the authority of City to grant such permission, which may now or hereafter exist.

8. Owner agrees to place parking bumper or City Engineer approved barrier to prevent vehicle traffic from entering the sidewalk adjacent to the parking encroachment area.

9. It is specifically understood and agreed that the City retains authority to operate and maintain existing above ground and underground municipal facilities in the encroachment area. In the event the City needs to permanently retake the encroachment area for public use, City will provide Owner written notice ninety (90) days in advance to remove the encroaching private facilities. Further, this agreement shall terminate if the encroaching property is repaired, reconstructed or improved at a cost of 25% or more of the market value of the property prior to such improvement or repair. If the encroaching property is damaged, market value will be determined as the value before the damage occurred.

10. It is specifically agreed between the parties that a copy of this Encroachment Agreement may be recorded.

11. Owner agrees to pay City a \$500 processing fee.

Dated this ____ day of _____, 2017.

PROJECT BENCH-
TOP NUT OF HYD
904.35 (NAVD 198)

DESCRIPTION - ENCROACHMENT EASEMENT:

That part of the right-of-way of 10th Avenue South lying adjacent to the east side of 10th Avenue South, Fargo, Cass County, North Dakota, described as follows:

A 6.00-foot wide strip of land lying northerly of and being

BEGINNING at the northeast corner of Lot 14, said E 1/4 (bearing), along the northerly line of said Lot 14, for a distance of 6.00 feet, and there terminating said line.

Said tract contains 840 square feet.

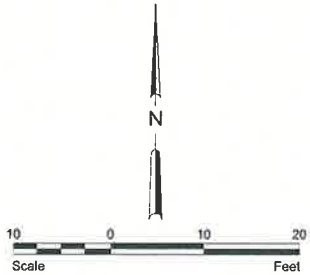

LEGEND

- MANHOLE
- FIRE HYDRANT
- UTILITY POLE
- W / GUY WIRE
- LIGHT POLE
- OVERHEAD POWER
- DECIDUOUS TREE
- SPOT ELEVATION
- STANDARD CURB & GUTTER
- MOUNTABLE CURB & GUTTER
- BUILDING
- IRON MONUMENT FOUND
- IRON MONUMENT SET
- ENCROACHMENT EASEMENT

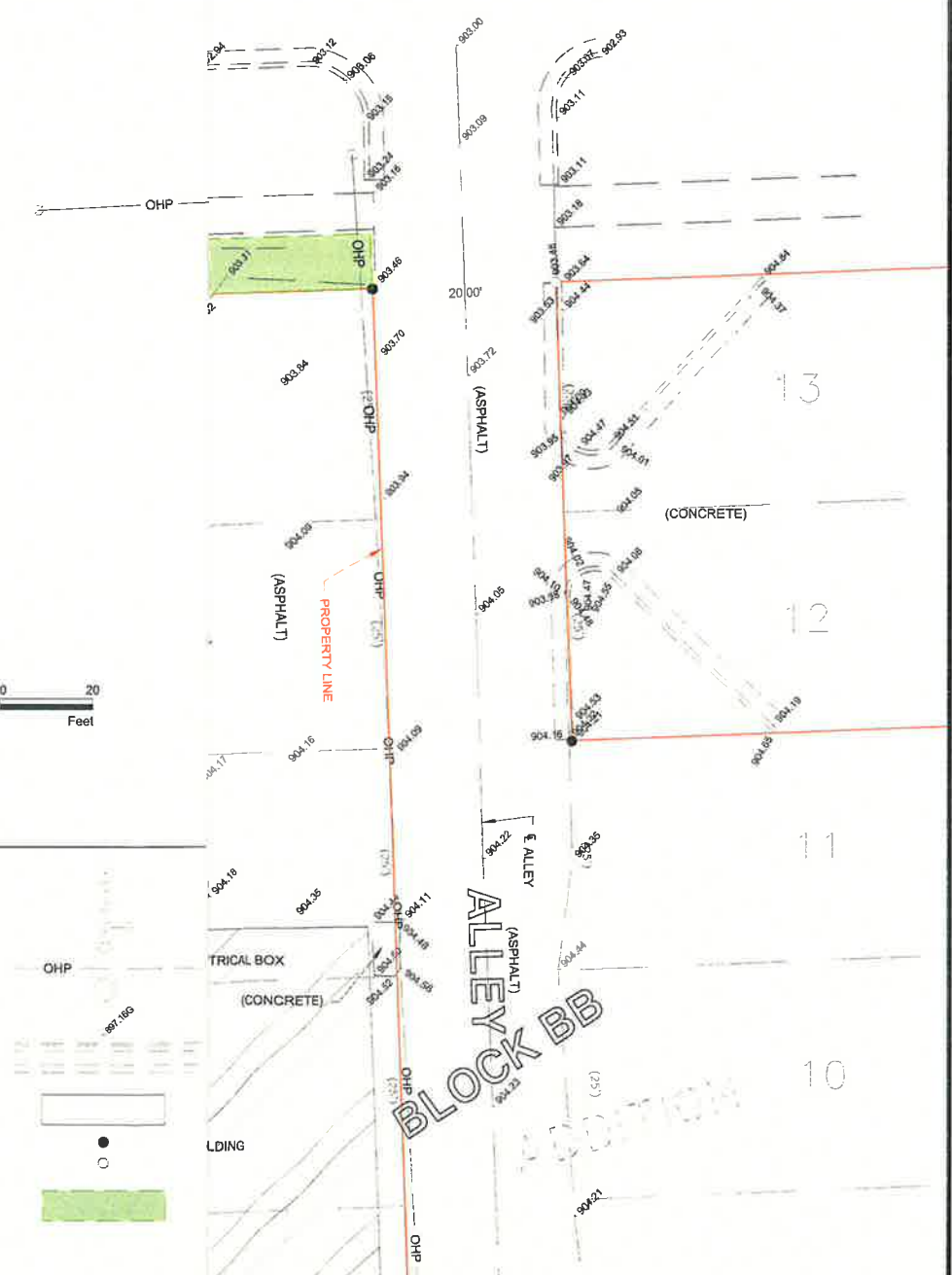

H:\Fargo\IBN\7354\17_7354_002\CAD\Plans\Encroach_Agree_Salem\Free.dwg

No.	Revision	Date	THE CHURCH	ENCROACHMENT EASEMENT EXHIBIT	SHEET	1 of 1			
				PROJECT NO. 7354-002					

REPORT OF ACTION

20

PUBLIC WORKS PROJECTS EVALUATION COMMITTEE

Type: NDDOT Maintenance Certification

Location: City Wide

Date of Hearing: 10/16/2017

<u>Routing</u>	<u>Date</u>
City Commission	<u>10/23/2017</u>
PWPEC File	<u>X</u>
Project File	<u>Jeremy Gorden</u>

Every year the State seeks the attached certification indicating that the City continues to maintain in appropriate condition any street project funded with FHWA funds.

Staff is recommending approval.

On a motion by Bruce Grubb, seconded by Ben Dow, the Committee voted to recommend approval of the execution of the certification document.

RECOMMENDED MOTION

Concur with the recommendation of PWPEC and approve the execution of the annual maintenance certification.

PROJECT FINANCING INFORMATION:

Recommended source of funding for project: N/A

Developer meets City policy for payment of delinquent specials
 Agreement for payment of specials required of developer
 Letter of Credit required (per policy approved 5-28-13)

<u>Yes</u>	<u>No</u>
<u>N/A</u>	<u>N/A</u>
<u>N/A</u>	<u>N/A</u>
<u>N/A</u>	<u>N/A</u>

COMMITTEE

Tim Mahoney, Mayor
 Jim Gilmour, Director of Planning
 Steve Dirksen, Fire Chief
 Mark Bittner, Director of Engineering
 Bruce Grubb, City Administrator
 Ben Dow, Director of Operations
 Steve Sprague, City Auditor
 City Engineer
 Kent Costin, Finance Director

<u>Present</u>	<u>Yes</u>	<u>No</u>	<u>Unanimous</u>
<input checked="" type="checkbox"/>	<input checked="" type="checkbox"/>	<input type="checkbox"/>	<input checked="" type="checkbox"/>
<input checked="" type="checkbox"/>	<input checked="" type="checkbox"/>	<input type="checkbox"/>	
<input checked="" type="checkbox"/>	<input checked="" type="checkbox"/>	<input type="checkbox"/>	Ryan Erickson
<input checked="" type="checkbox"/>	<input checked="" type="checkbox"/>	<input type="checkbox"/>	
<input checked="" type="checkbox"/>	<input checked="" type="checkbox"/>	<input type="checkbox"/>	
<input checked="" type="checkbox"/>	<input checked="" type="checkbox"/>	<input type="checkbox"/>	
<input checked="" type="checkbox"/>	<input checked="" type="checkbox"/>	<input type="checkbox"/>	Brenda Derrig
<input checked="" type="checkbox"/>	<input checked="" type="checkbox"/>	<input type="checkbox"/>	

ATTEST:

C: Kristi Olson

 Brenda E. Derrig, P.E.
 Division Engineer

October 11, 2017

To: Members of PWPEC

From: Jeremy M. Gorden, PE, PTOE *JMG*
Division Engineer - Transportation

Subject: Maintenance Certification for Urban Federal Aid Projects for NDDOT

I have attached a **Maintenance Certification** for all of our completed Urban Federal Aid Projects that our Auditor's Office received last week from the Local Government Division of the NDDOT. The NDDOT requires that City's maintain, in appropriate condition, any street project funded in total or in part by FHWA funds. Maintenance requirements are spelled out in the project specific Cost Participation and Maintenance Agreement. The NDDOT sends this certificate our annually for local governments to approve.

Recommended Motion

Approve this Maintenance Certification for the NDDOT and return it signed to them by November 17, 2017.

JMG/jmg
Attachment

MEMO TO: City Engineer

FROM: Paul M. Benning, Local Government Engineer *PMB*

DATE: October 4, 2017

SUBJECT: Maintenance Certification

Enclosed is the annual Maintenance Certification for urban federal aid projects for you to sign and return to my office by **November 17, 2017**. This certification states that your city is properly maintaining the projects that had federal aid for construction.

Also, enclosed is a **sample** "Cost Participation, Construction, and Maintenance Agreement" similar to one you have signed for each federal aid construction project (See pages 3 and 4). This does *not* need to be returned as it is for your information only.

If you have any questions, please call me at 701-328-2217.

38/sh/sh
Enclosures

**MAINTENANCE CERTIFICATION
URBAN FEDERAL AID PROJECT**

North Dakota Department of Transportation, Local Government
SFN 51027 (8-2017)

All federal aid street projects have been inspected and are being maintained in a good and safe condition for general public use. Maintenance is in accordance with the North Dakota Department of Transportation "Cost Participation and Maintenance Agreements".

Approved as to form:

City Attorney (Type or print) <i>Erik Johnson</i>
Signature

City of <i>Fargo, ND</i>
Date

City Auditor (Type or print) <i>Steve Sprague</i>
Signature

Mayor or President City Commission (Type or print) <i>Tim Mahoney</i>
Signature

Recommended for approval

City Engineer (Type or print) <i>Mark H. Bittner</i>
Signature <i>Mark H. Bittner</i>

NDDOT Contract No. \${FIELD:CONTRACT_NUMBER}

**North Dakota Department of Transportation
COST PARTICIPATION, CONSTRUCTION, AND MAINTENANCE AGREEMENT
LPA FEDERAL AID PROJECT**

Federal Award Information – to be provided by NDDOT

CFDA No: 20.205

CFDA Title: Highway Planning & Construction

Award Name: Federal Aid Highway Program

Awarding Fed. Agency: Federal Highway Admin

NDDOT Program Mgr: \${FIELD:CONTRACT_MGR_NAME}

Telephone:

Notice to Subrecipients: Federal awards may have specific compliance requirements. If you are not aware of the specific requirements for your award, please contact your NDDOT Program Manager.

For NDDOT use only.

FHWA Authorization date:

Project No. \${FIELD:PROJECT_NUMBER}

Location: \${FIELD:LOCATION}

Type of Improvement:

LPA:

Length:

This agreement is between the state of North Dakota acting by and through its Director of Transportation, hereinafter referred to as NDDOT, whose address is 608 East Boulevard Avenue, Bismarck, North Dakota 58505-0700, and the Local Public Agency (LPA) of _____ North Dakota, hereinafter referred to as the LPA, who agree that:

It is in the best interest of both parties to have the LPA construct and maintain this project according to the terms and conditions set forth in this agreement. NDDOT will assist the LPA with the preparation and distribution of the bid documents and include the project in a scheduled bid opening.

The LPA agrees to the terms and conditions required for this project by the Federal Highway Administration (FHWA).

NDDOT will procure federal funds for the construction of the project, pursuant to Title 23 of the United States Code.

Federal funds obligated for this project shall not exceed _____ percent of the total eligible project cost. The balance of the project cost is \$ _____, with the LPA's estimated share being \$ _____.

Additional Funding Clause

The total eligible project costs include the cost of those items shown in the engineer's detailed estimate as approved for federal funds and any project changes approved by NDDOT for the use of federal funds.

Federal funds may not be obligated by the LPA, prior to FHWA approval of the program documents for the project.

PART I

LPA Obligation:

1. To comply with the Disadvantaged Business Enterprise (DBE) requirements established by NDDOT for the project.

The LPA shall not discriminate on the basis of race, color, national origin, or sex in the award and performance of any USDOT-assisted contract or in the administration of its DBE program or the requirements of 49 CFR Part 26. The LPA shall take all necessary and reasonable steps under 49 CFR Part 26 to ensure nondiscrimination in the award and administration of USDOT-assisted contracts. NDDOT's DBE program, as required by 49 CFR Part 26 and as approved by USDOT, is incorporated by reference in this agreement. Implementation of this program is a legal obligation and failure to carry out its terms shall be treated as a violation of this agreement. Upon notification to the LPA of its failure to carry out its approved program, the USDOT may impose sanctions as provided for under 18 U.S.C. 1001 and/or the Program Fraud Civil Remedies Act of 1986 (31 U.S.C. 3801 et. Seq.).

Include the following paragraph verbatim in any subcontracts they sign relative to this project:

The contractor or subcontractor shall not discriminate on the basis of race, color, national origin, or sex in the performance of this contract. The contractor shall carry out applicable requirements of 49 CFR Part 26 in the solicitation, award, and administration of USDOT-assisted contracts. Failure by the contractor to carry out these requirements is a material breach of this contract, which may result in the termination of this contract or such other remedy as NDDOT deems appropriate.

2. To comply with requirements of 23 CFR Part 633, Required Contract Provisions, and 23 CFR Part 635, Construction and Maintenance.
3. To construct the project in conformity with the construction contract, changes to the plans shall meet the requirements of 23 CFR Part 625, Design Standards for Highways and the current edition of the NDDOT's *Local Government Manual*.
4. To construct the project in conformity with the approved environmental documents and provide for the implementation of any measures mitigating the environmental impact of the project.
5. To comply with the procedures outlined in the current edition of NDDOT's *Local Government Manual*.
6. To comply with the current edition of NDDOT's *Right of Way Acquisition Procedures for Local Public Agency Federal Aid Projects*.
7. The LPA will be responsible for any consideration, avoidance, and minimization of impacts upon real property related to this project, such as changes in the grades of streets, inconvenience to property or business, and any loss of light, air, view, access, egress, drainage, support, or nuisance,
8. To comply with the requirements of Appendices A and E of the Title VI Assurances, attached and incorporated by reference herein.

PART II

Contracting and Construction:

1. On behalf of the LPA, NDDOT will:
 - a. Prepare the bid package, solicit proposals, and include the project in a scheduled bid opening as provided in the North Dakota Century Code, Chapter 24-02.
 - b. Evaluate the bids as to the sufficiency of Disadvantaged Business Enterprise (DBE) participation and the bidder's good faith efforts in satisfying the requirements of the current edition of the DBE special provision, and 49 CFR Part 26. NDDOT shall have exclusive authority in evaluating the adequacy of DBE participation.
 - c. Tabulate the bids and send to the LPA.
 - d. Concur in the award of the contract, after the LPA has executed the contract, for the sole purpose of enabling the LPA to procure federal aid for the construction of the project.
2. The LPA will:
 - a. Review bids to determine the lowest responsible bidder.
 - b. Execute the contract.
 - c. Distribute copies of the executed contract and contract bond to NDDOT.
3. During the construction of the project, the LPA will:
 - a. Provide engineering services, material testing, and inspection of the work as required by the contract documents and the current editions of NDDOT's *Sampling and Testing Manual* and the *Standard Specifications for Road and Bridge Construction*.
 - b. Keep all project records and documentation as required in NDDOT's current editions of the *Construction Records Manual* and the *Construction Automated Records System*.
 - c. Make all records available to NDDOT and FHWA for inspection upon request. The LPA will submit all documents and records to NDDOT for review before final payment is made. NDDOT will maintain the project records for three years from the final voucher date of FHWA and then return them to the LPA.
 - d. Be responsible for any changes in plan, character of work, quantities, site conditions, or any claim for extra compensation. NDDOT will review all contract adjustments to determine if the adjustments are eligible for federal aid. Federal aid shall be limited to the amount stated on page one of this agreement.

PART III

Post Construction:

After the project is completed the LPA agrees to:

1. If the traffic corridor intersects a state highway, the LPA must justify to NDDOT that any new access allowed will have minimal impact to the state highway. The design will meet the requirements of 23 CFR Part 625, Design Standards for Highways.

2. Maintain the signing and marking of the project according to the current edition of the *Manual on Uniform Traffic Control Devices for Streets and Highways*, as supplemented and amended.
3. Restrict the speed limit on the project at or below the maximum design speed. Any changes to the speed limit will be pursuant to North Dakota Century Code, Chapter 39-09.
4. Provide maintenance to the completed project at its own cost and expense.
5. Prohibit access and encroachments upon the right of way pursuant to 23 CFR Part 1.23, Rights of Way, and Part 710 Subpart D, Right of Way, Real Property Management.

PART IV

General:

1. NDDOT will make all contract payments on behalf of the LPA. Payment will be made upon receipt of the engineer's estimate. The LPA will reimburse NDDOT for payments made less the amount paid by FHWA. No costs will be incurred by NDDOT for the construction and maintenance of this project.

If the LPA fails to reimburse NDDOT within 60 days after billing for funds advanced on behalf of the LPA, this document will constitute an assignment of funds now or hereafter coming into the hands of the state treasurer, which would otherwise be distributed to the LPA out of the highway tax distribution fund, NDCC 54-27-19. The state treasurer is hereby directed to pay NDDOT all such funds until the total equals the sum billed pursuant to this agreement.

2. The Risk Management Appendix, attached, is hereby incorporated and made a part of this agreement.
3. No official, employee, or other person performing services for the LPA who is authorized to negotiate or approve any contract or subcontract in connection with the project shall have any financial or other personal interest in any such contract or subcontract. No officer or employee of such person retained by the LPA shall have any financial or other personal interest in any real property acquired for the project unless such interest is openly disclosed upon public records of NDDOT and of the LPA, and such officer, employee, or person has not participated in such acquisition for and in behalf of the LPA.
4. The failure of the state to enforce any provisions of this contract shall not constitute a waiver by the state of that or any other provision.
5. Entities that receive federal funds through NDDOT may be required to obtain an audit in accordance with 2 C.F.R. Part 200, Subpart F. A copy of such audit shall be submitted to NDDOT. Entities that spend less than \$750,000 of federal funds from all sources may be subject to reviews by NDDOT at its discretion. Additionally, all entities receiving federal funds through NDDOT shall certify whether a Single Audit has been completed as part of the annual Federal award process. These requirements are applicable to counties, cities, state agencies, Indian tribes, colleges, hospitals, and non-profit businesses.
6. All notices, certificates, or other communications shall be sufficiently given when delivered or mailed, postage prepaid, to the parties at the respective places of business as set forth below or at a place designated hereafter in writing by the parties.

Local Government Engineer
ND Department of Transportation

608 East Boulevard Avenue
Bismarck, ND 58505-0700

7. The LPA is advised that its signature on this contract or agreement certifies that any person associated therewith is not currently under suspension, debarment, voluntary exclusion, or determination of ineligibility by any federal agency; has not been suspended, debarred, voluntarily excluded, or determined ineligible by any federal agency within the past three years; and has not been indicted, convicted, or had a civil judgment rendered against it by a court of competent jurisdiction on any matter involving fraud or official misconduct within the past three years.
8. This agreement constitutes the entire agreement between the parties. No waiver consent, modification or change of terms of this agreement shall bind either party unless in writing and signed by both parties. Such waiver, consent, modification or change, if made, shall be effective only in the specific instance and for the specific purpose given. There are no understandings, agreements, or representations, oral or written, not specified herein regarding this agreement. The LPA, by the signature below of its authorized representative, hereby acknowledges that the LPA has read this agreement, understands it, and agrees to be bound by its terms and conditions.

SAMPLE

Executed by the LPA of _

, North Dakota, the date last below signed.

APPROVED:

CITY/STATES ATTORNEY (TYPE OR PRINT)

SIGNATURE

DATE

LPA of _

*

NAME (TYPE OR PRINT)

SIGNATURE

*

TITLE

DATE

ATTEST:

AUDITOR (TYPE OR PRINT)

SIGNATURE

DATE

Executed by the North Dakota Department of Transportation, the date last below signed.

NORTH DAKOTA
DEPARTMENT OF TRANSPORTATION

APPROVED as to substance:

LOCAL GOVERNMENT ENGINEER (TYPE OR PRINT)

SIGNATURE

DATE

DIRECTOR (TYPE OR PRINT)

SIGNATURE

DATE

*Mayor, President or Chairperson of Commission

CLA 19256 (Div. 38)
L.D. Approved 4-12-93; 8-17



CERTIFICATION OF LOCAL MATCH

It is hereby certified that the LPA of _ will provide non-federal funds, whose source is identified below, as match for the amount the LPA is obligated to pay under the terms of the attached agreement with the North Dakota Department of Transportation. The certified amount does not duplicate any federal claims for reimbursement, nor are the funds used to match other federal funds, unless expressly allowed by federal regulation.

Non-Federal Match Funds provided by LPA. Please designate the source(s) of funds in the LPA budget that will be used to match the federal funds obligated for this project through the North Dakota Department of Transportation.

Source:

Executed at _ , North Dakota, the last date below signed.

ATTEST:

AUDITOR (TYPE OR PRINT)

APPROVED:

LPA C

SIGNATURE

NAME (TYPE OR PRINT)

DATE

SIGNATURE

TITLE

DATE

*Mayor, President or Chairperson of Commission

CLA 19256 (Div. 38)
L.D. Approved 4-12-93; 8-17

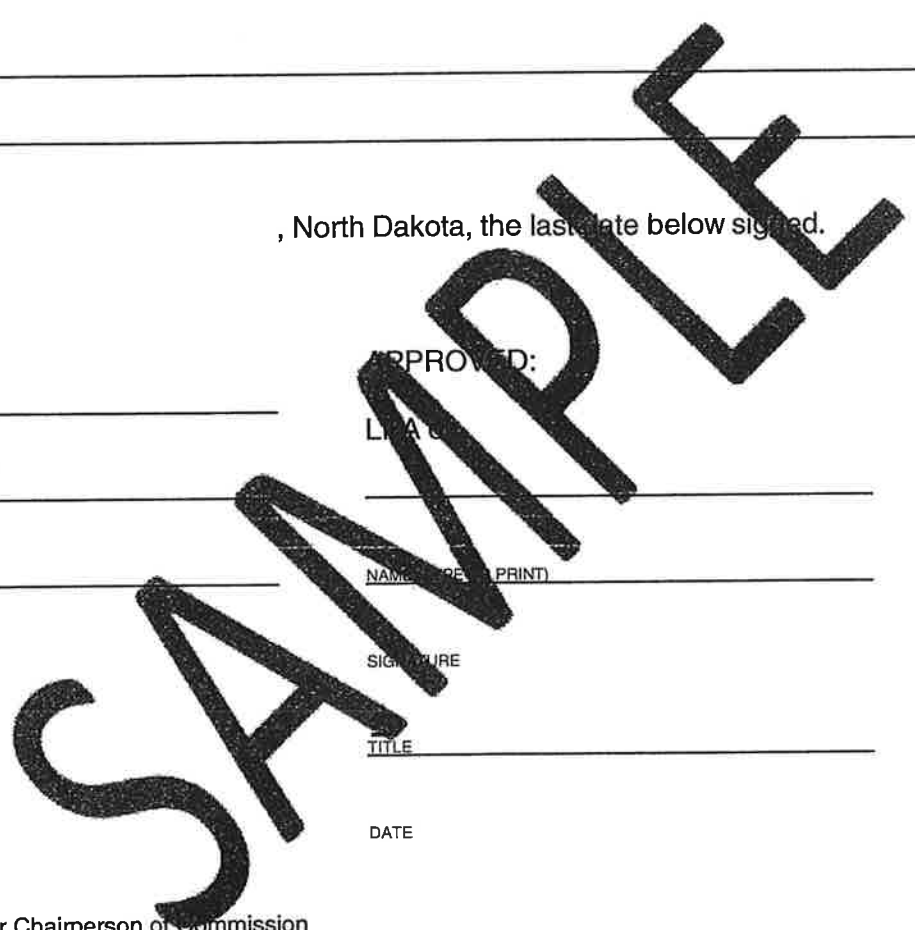

**NORTH DAKOTA DEPARTMENT OF TRANSPORTATION
APPENDIX A OF THE TITLE VI ASSURANCES**

During the performance of this contract, the Contractor, for itself, its assignees, and successors in interest (hereinafter referred to as the Contractor) agrees as follows:

1. Compliance with Regulations: The Contractor (hereinafter includes consultants) will comply with the Acts and the Regulations relative to Non-discrimination in Federally-assisted programs of the U.S. Department of Transportation, the Federal Highway Administration, as they may be amended from time to time, which are herein incorporated by reference and made a part of this contract.
2. Non-discrimination: The Contractor, with regard to the work performed by it during the contract, will not discriminate on the grounds of race, color, or national origin in the selection and retention of subcontractors, including procurements of materials and leases of equipment. The Contractor will not participate directly or indirectly in the discrimination prohibited by the Acts and the Regulations, including employment practices when the contract covers any activity, project, or program set forth in Appendix B of 49 CFR Part 21.
3. Solicitations for Subcontracts, Including Procurements of Materials and Equipment: In all solicitations, either by competitive bidding, or negotiation made by the Contractor for work to be performed under a subcontract, including procurements of materials, or leases of equipment, each potential subcontractor or supplier will be notified by the Contractor of the Contractor's obligations under this contract and the Acts and the Regulations relative to Non-discrimination on the grounds of race, color, or national origin.
4. Information and Reports: The Contractor will provide all information and reports required by the Acts, the Regulations, and directives issued pursuant thereto, and will permit access to its books, records, accounts, other sources of information, and its facilities as may be determined by the Recipient or the Federal Highway Administration to be pertinent to a certain compliance with such Acts, Regulations, and instructions. Where any information required of a Contractor is in the exclusive possession of another who fails or refuses to furnish the information, the Contractor will so certify to the Recipient or the Federal Highway Administration as appropriate and will set forth what efforts it has made to obtain the information.
5. Sanctions for Noncompliance: In the event of a contractor's noncompliance with the Non-discrimination provisions of this contract, the Recipient will impose such contract sanctions as it or the Federal Highway Administration may determine to be appropriate, including, but not limited to:
 - a. withholding payments to the Contractor under the contract until the Contractor complies; and/or
 - b. cancelling, terminating, or suspending a contract, in whole or in part.
6. Incorporation of Provisions: The Contractor will include the provisions of paragraphs one through six in every subcontract, including procurements of materials and leases of equipment, unless exempt by the Acts, the Regulations and directives issued pursuant thereto. The Contractor will take action with respect to any subcontract or procurement as the Recipient or the Federal Highway Administration may direct as a means of enforcing such provisions including sanctions for noncompliance. Provided, that if the Contractor becomes involved in, or is threatened with litigation by a subcontractor, or supplier because of such direction, the Contractor may request the Recipient to enter into any litigation to protect the interests of the Recipient. In addition, the Contractor may request the United States to enter into the litigation to protect the interests of the United States.

**NORTH DAKOTA DEPARTMENT OF TRANSPORTATION
APPENDIX E OF THE TITLE VI ASSURANCES**

During the performance of this contract, the contractor, for itself, its assignees, and successors in interest (hereinafter referred to as the Contractor) agrees to comply with the following non-discrimination statutes and authorities; including but not limited to:

Pertinent Non-Discrimination Authorities:

- Title VI of the Civil Rights Act of 1964 (42 U.S.C. § 2000d *et seq.*, 78 stat. 252), (prohibits discrimination on the basis of race, color, national origin); and 49 CFR Part 21.
- The Uniform Relocation Assistance and Real Property Acquisition Policies Act of 1970, (42 U.S.C. § 4601), (prohibits unfair treatment of persons displaced or whose property has been acquired because of Federal or Federal-aid programs and projects);
- Federal-Aid Highway Act of 1973, (23 U.S.C. § 324 *et seq.*), (prohibits discrimination on the basis of sex);
- Section 504 of the Rehabilitation Act of 1973, (29 U.S.C. § 794 *et seq.*), as amended, (prohibits discrimination on the basis of disability); and 49 CFR Part 27;
- The Age Discrimination Act of 1975, as amended, (42 U.S.C. § 6101 *et seq.*), (prohibits discrimination on the basis of age);
- Airport and Airway Improvement Act of 1982, (49 USC § 471, Section 47123), as amended, (prohibits discrimination based on race, creed, color, national origin, or sex);
- The Civil Rights Restoration Act of 1987, (PL 100-503) (Broadened the scope, coverage and applicability of Title VI of the Civil Rights Act of 1964, The Age Discrimination Act of 1975 and Section 504 of the Rehabilitation Act of 1973, by expanding the definition of the terms "programs or activities" to include all of the programs or activities of the Federal-aid recipients, sub-recipients and contractors, whether such programs or activities are federally funded or not);
- Titles II and III of the Americans with Disabilities Act, which prohibit discrimination on the basis of disability in the operation of public entities, public and private transportation systems, places of public accommodation, and certain private entities (42 U.S.C. §§ 12131-12189) as implemented by Department of Transportation Regulations at 49 C.F.R. parts 37 and 38;
- The Federal Aviation Administration's Non-discrimination statute (49 U.S.C. § 47123) (prohibits discrimination on the basis of race, color, national origin, and sex);
- Executive Order 12898, Federal Actions to Address Environmental Justice in Minority Populations and Low-Income Populations, which requires non-discrimination against minority populations by discouraging programs, policies, and activities with disproportionately high and adverse human health or environmental effects on minority and low-income populations;
- Executive Order 13166, Improving Access to Services for Persons with Limited English Proficiency, and resulting agency guidance, national origin discrimination includes discrimination because of limited English proficiency (LEP). To ensure compliance with Title VI, you must take reasonable steps to ensure that LEP persons have meaningful access to your programs (70 Fed. Reg. at 74087 to 74100);
- Title IX of the Education Amendments of 1972, as amended, which prohibits you from discriminating because of sex in education programs or activities (20 U.S.C. 1681 *et seq.*).

PUBLIC WORKS PROJECTS EVALUATION COMMITTEE

Project No. QN-17-B1 (LN-17-B1) Type: Bridge Maintenance
 Location: 52nd Avenue South at the Red River Date of Hearing: 10/16/2017

Routing Date
 City Commission 10/23/2017
 PWPEC File X
 Project File Jeremy Gorden

The Committee reviewed a communication from Transportation Division Engineer, Jeremy Gorden, regarding this project. Last fall we had Clay County move ahead with a bridge maintenance project for the 52nd Avenue S Bridge over the Red River. It entailed fixing an expansion joint, deck spall repair, and painting under the expansion joint fix area. That project totaled \$143,688.38, and we split it 50/50 amounting to \$71,844.19. That completed the work for 2016. This summer we also needed to complete some grading on the Fargo side that is located underneath the bridge itself and add riprap to stabilize the ground. Clay County took the lead on this as well. They reached out to four (4) contractors for quotes for this work.

The quotes are as follows:

Key Contracting	\$ 58,000
Excavating Inc.	\$ 68,800
H&S Contracting	\$ 74,825
Industrial Builders, Inc.	\$ 95,525

Clay County also had some billables for this work, totaling \$973.85.

On a motion by Mark Bittner, seconded by Bruce Grubb, the Committee voted to recommend concurrence with the low quote from Key Contracting and approve final payment to the Clay County Highway Department in the amount of \$29,486.92.

RECOMMENDED MOTION

Concur with the recommendations of PWPEC approving concurrence with the low quote from Key Contracting and approve final payment to the Clay County Highway Department in the amount of \$29,486.92.

PROJECT FINANCING INFORMATION:

Recommended source of funding for project: Street Rehabilitation Funds

	Yes	No
Developer meets City policy for payment of delinquent specials	<u>N/A</u>	<u> </u>
Agreement for payment of specials required of developer	<u>N/A</u>	<u> </u>
Letter of Credit required (per policy approved 5-28-13)	<u>N/A</u>	<u> </u>

COMMITTEE

	Present	Yes	No	Unanimous
				<input checked="" type="checkbox"/>
Tim Mahoney, Mayor	<input checked="" type="checkbox"/>	<input checked="" type="checkbox"/>	<input type="checkbox"/>	
Jim Gilmour, Director of Planning	<input checked="" type="checkbox"/>	<input checked="" type="checkbox"/>	<input type="checkbox"/>	
Steve Dirksen, Fire Chief	<input checked="" type="checkbox"/>	<input checked="" type="checkbox"/>	<input type="checkbox"/>	Ryan Erickson
Mark Bittner, Director of Engineering	<input checked="" type="checkbox"/>	<input checked="" type="checkbox"/>	<input type="checkbox"/>	
Bruce Grubb, City Administrator	<input checked="" type="checkbox"/>	<input checked="" type="checkbox"/>	<input type="checkbox"/>	
Ben Dow, Director of Operations	<input checked="" type="checkbox"/>	<input checked="" type="checkbox"/>	<input type="checkbox"/>	
Steve Sprague, City Auditor	<input checked="" type="checkbox"/>	<input checked="" type="checkbox"/>	<input type="checkbox"/>	
City Engineer	<input checked="" type="checkbox"/>	<input checked="" type="checkbox"/>	<input type="checkbox"/>	Brenda Derrig
Kent Costin, Finance Director	<input checked="" type="checkbox"/>	<input checked="" type="checkbox"/>	<input type="checkbox"/>	

ATTEST:

C: Kristi Olson

 Brenda E. Derrig, P.E.
 Division Engineer

ENGINEERING DEPARTMENT

200 3rd Street North
Fargo, North Dakota 58102
Phone: (701) 241-1545
Fax: (701) 241-8101
E-Mail: feng@cityoffargo.com

Memo

October 10, 2017

To: PWPEC

From: Jeremy Gorden, P.E., PTOE *Jmg*
Division Engineer - Transportation

Subject: Concur with Clay County Highway Department for Approval of Quotes for 52nd Avenue S Bridge Maintenance Work and Approve Final Payment
City of Fargo Project No. QN-17-B1

If you recall, last fall we had Clay County move ahead with a bridge maintenance project for the 52nd Avenue S bridge over the Red River. It entailed fixing an expansion joint, deck spall repair, and painting under the expansion joint fix area. That project totaled \$143,688.38, and we split it 50/50 amounting to \$71,844.19.

Fast forward to this summer, we also needed to complete some grading on the Fargo side that is located underneath the bridge itself, and add rip-rap to stabilize the ground. Clay County took the lead on this as well. They reached out to four (4) contractors for quotes for this work.

The quotes are as follows:

Key Contracting	\$ 58,000
Excavating Inc.	\$ 68,800
H&S Contracting	\$ 74,825
Industrial Builders, Inc.	\$ 95,525

Clay County also had some billables for this work, totaling \$973.85.

Recommended Motion

Concur with the low quotes from Key Contracting, and approve payment to Clay County Highway Department for \$29,486.92.

JMG/klo
Attachments

HIGHWAY DEPARTMENT
 DAVID L OVERBO, Engineer
 ERIK HOVE, Assistant Engineer

Office: (218) 299-5099
 Fax: 1-888-259-8757



City of Fargo
 Attn: Engineering Department
 200 3 St N
 Fargo, ND 58102

BILLING DATE: SEPTEMBER 26, 2017

Acct # 90

ACCOUNT CHARGES	AMOUNT
County State Aid Highway 12 (60th Ave S) Bridge - Scour Hole Repair Work Completed September 20, 2017	
Labor	943.85
Equipment	30.00
Key Contracting Inc.	58,000.00
Total Bridge Repair	\$ 58,973.85
Clay County's Share (50% of \$58,973.85)	(29,486.93)
<p>* Key Contracting Inc. invoice attached * Itemized Charges on Succeeding Page</p>	
BALANCE DUE	\$ 29,486.92

Approved: 
 Clay County Highway Engineer

Please make check payable to: CLAY COUNTY HIGHWAY DEPARTMENT

Please send remittance to: Clay County Auditor Office
 807 North 11th Street
 PO Box 280
 Moorhead, Minnesota 56560

RED RIVER BRIDGE REPAIR AT 60th AVE SOUTH

DATE	EMP #	EMPLOYEE	HOURS	RATE	AMOUNT	FRINGE	LABOR TOTAL	EQUIP #	EQUIPMENT	HOURS	RATE	EQUIP TOTAL
3/29/2017	203	BEAUDRY, LEE	1.00	30.49	30.49	13.41	43.90					
4/3/2017	203	BEAUDRY, LEE	2.00	30.49	60.98	26.81	87.79	1195	2015 GMC SIERRA PICKUP	0.50	10.00	5.00
4/4/2017	203	BEAUDRY, LEE	2.00	30.49	60.98	26.81	87.79					
4/6/2017	203	BEAUDRY, LEE	2.50	30.49	76.23	33.52	109.75					
4/13/2017	203	BEAUDRY, LEE	0.50	30.49	15.25	6.71	21.96					
4/19/2017	203	BEAUDRY, LEE	1.00	30.49	30.49	13.41	43.90					
4/20/2017	203	BEAUDRY, LEE	3.00	30.49	91.47	40.22	131.69	1195	2015 GMC SIERRA PICKUP	1.00	10.00	10.00
4/21/2017	203	BEAUDRY, LEE	1.00	30.49	30.49	13.41	43.90					
4/27/2017	203	BEAUDRY, LEE	0.50	30.49	15.25	6.71	21.96					
5/1/2017	203	BEAUDRY, LEE	1.50	30.49	45.74	20.11	65.85					
5/2/2017	203	BEAUDRY, LEE	1.00	30.49	30.49	13.41	43.90					
5/9/2017	203	BEAUDRY, LEE	1.00	30.49	30.49	13.41	43.90					
5/10/2017	203	BEAUDRY, LEE	1.00	30.49	30.49	13.41	43.90					
5/10/2017	203	BEAUDRY, LEE	1.00	30.49	30.49	13.41	43.90					
7/25/2017	203	BEAUDRY, LEE	1.00	30.49	30.49	13.41	43.90	1195	2015 GMC SIERRA PICKUP	0.50	10.00	5.00
9/18/2017	203	BEAUDRY, LEE	1.00	30.49	30.49	13.41	43.90	1195	2015 GMC SIERRA PICKUP	0.50	10.00	5.00
9/19/2017	203	BEAUDRY, LEE	1.00	30.49	30.49	13.41	43.90	1195	2015 GMC SIERRA PICKUP	0.50	10.00	5.00
9/20/2017	203	BEAUDRY, LEE	0.50	30.49	15.25	6.71	21.96					
							LABOR / EQUIPMENT TOTAL					30.00
							943.85					

973.85

DATE	VENDOR #	VENDOR	VENDOR TOTAL
9/20/2017	8154	KEY CONTRACTING, INC.	58,000.00
			OUTSIDE VENDOR TOTAL

58,000.00

TOTAL RED RIVER BRIDGE REPAIR

58,973.85

Key Contracting, Inc.

245 7th Avenue NE
West Fargo, ND 58078

Invoice

Date	Invoice #
9/20/2017	5375

Bill To
Clay County Minnesota 2951 41 1/2 Street South Moorhead, MN 56560



P.O. Number	Terms	Project

Quantity	Description	Rate	Amount
1	Repairing bridge, rip rap fabric, clay and seeding <i>< SA# 12 Bridge</i>	58,000.00	58,000.00

The work is complete. Please pay from this invoice. Thank you for the business.

Total \$58,000.00

Phone #
701-238-8192

Fax #
701-356-0166

Web Site
www.keycontracting.com

Key Contracting, Inc.

245 7th Avenue NE

West Fargo, North Dakota 58078

Phone: (701) 238-8192

Fax: (701) 356-0166

Internet: keycontracting.com



PROPOSAL AND ACCEPTANCE

Submitted To:	Clay County Highway Department
Date:	4/21/2017
Project:	Bridge Repair
Project Location:	Convent Road
Total Price	\$58,000.00

Key Contracting, Inc., hereby submits an estimate for all labor and materials for:

Repairing bridge. Includes riprap, fabric, clay and seeding.
Total price: \$58,000

All materials are guaranteed as specified.

All work shall be completed in a workman like manner and according to standard practice.

Any alteration or deviation from the specifications shall be upon written change orders only.

This proposal shall be deemed to be withdrawn unless accepted in writing within 14 days.

Dated as noted above.

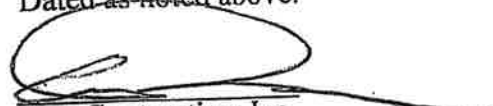
Key Contracting, Inc.

Tom Paschke 701-238-5339

This proposal was accepted on 5-9-17

By: 
Authorized Signature

Title: Clay County Engineer

Clay County Highway Department Quote Summary

Project Name: Convent Bridge Scour Repair

Client: Clay County Highway Department

Contractor	Total Quote
Key Contracting	\$58,000.00
Excavating Inc.	\$68,800.00
H & S Contracting	\$74,825.00
Industrial Builders Inc.	\$92,525.00

The project consists of filling the Scour hole under the bridge located under span 1 & 2 on the North Dakota side with clay & compacting. Then putting down fabric and placing Class III Riprap. Approximate area is 60' wide X 100' long. Contractor required to provide erosion control measures and site restoration. Tree's along the South side of the bridge to be cut down prior to work commencing.

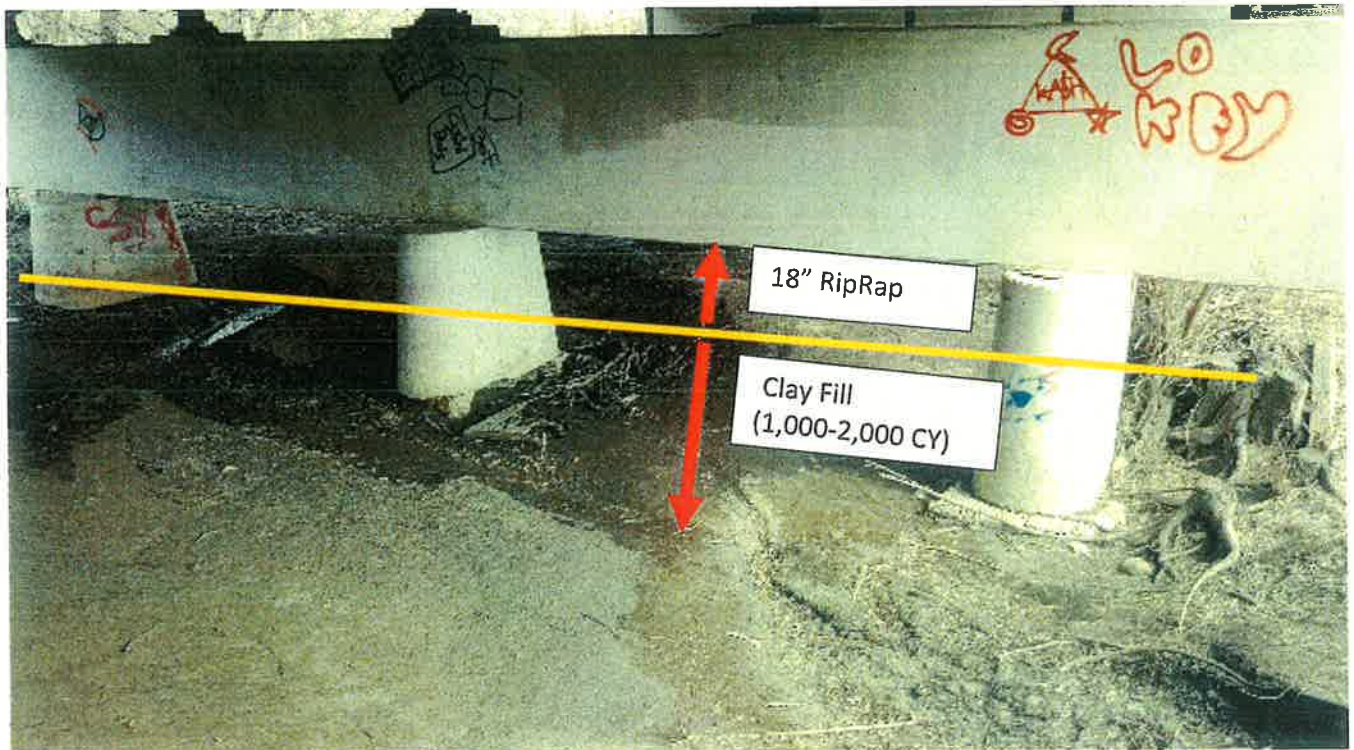



**In order to fill the scour hole about a dozen smaller trees (4" and smaller) need to be removed in order to place the fabric, haul in the clay fill and then top it off with approximately 18" of Class III RipRap.*



22

PUBLIC WORKS PROJECTS EVALUATION COMMITTEE

Improvement District No. QN-17-A1 Type: Local Funding Modification
TAU-8-984(154)157, PCN 21690

Location: Oak Grove/Memorial Parks Area over the Red River Date of Hearing: 10/16/2017

Routing Date
City Commission 10/23/2017
PWPEC File X
Project File Ron Solberg

The committee reviewed communication from Transportation Division Engineer, Jeremy Gorden, regarding the upcoming pedestrian bridge replacement project on the Oak Grove/Memorial Parks bridge over the Red River.

This project is getting funded from five (5) different funding sources; Federal Transportation Alternatives money from MN and ND, Fargo Park District, and the cities of Fargo and Moorhead. We originally planned for our Fargo local share to be in the form of Special Assessments but after discussing it internally, we believe that the Fargo local share should be in the form of Sales Tax funds. This project is currently set to be bid on November 17 by the NDDOT and will be placed on the next City Commission agenda for project creation.

Original Estimated Cost: \$1.35M
Original Estimated Revenues:
\$625k Moorhead/MN Fed funds
\$100k Fargo Park District
\$250k ND Fed funds
\$375k Special Assessments

Revised Estimated Cost: \$1.9M
Revised Estimated Revenues:
\$900k Moorhead/MN Fed funds
\$100k Fargo Park District
\$250k ND Fed funds
\$650k Sales Tax Funds

On a motion by Steve Sprague, seconded by Mark Bittner, the Committee voted to modify the Fargo share of the project to be 100% Sales Tax funds.

RECOMMENDED MOTION

Concur with the recommendations of PWPEC and modify the Fargo Share of the Oak Grove/Memorial Parks pedestrian lift bridge project to be 100% Sales Tax Funds.

PROJECT FINANCING INFORMATION:

Recommended source of funding for project: Federal, Sales Tax Funds, Fargo Park District & City of Moorhead

Table with 2 columns: Question, Yes/No. Rows include Developer meets City policy for payment of delinquent specials, Agreement for payment of specials required of developer, Letter of Credit required (per policy approved 5-28-13).

COMMITTEE

Table with 4 columns: Name, Present, Yes, No, Unanimous. Lists committee members and their voting status.

ATTEST:

C: Kristi Olson

Signature of Brenda E. Derrig, P.E.
Brenda E. Derrig, P.E.
Division Engineer

October 10, 2017

To: Members of PWPEC

From: Jeremy M. Gorden, PE, PTOE *JMG*
 Division Engineer-Transportation

Subject: 2017 Capital Improvement Plan Revision
 QN-17-A1 – Oak Grove/Memorial Parks Pedestrian Path Lift Bridge

Project No. QN-17-A1 - Oak Grove/Memorial Parks Pedestrian Path Lift Bridge Project

This project is getting funded from five (5) different funding sources; Federal Transportation Alternatives money from MN and ND, Fargo Park District, and the Cities of Fargo and Moorhead. We originally planned for our Fargo local share to be in the form of Special Assessments but after discussing it internally, we believe that the Fargo local share should be in the form of Sales Tax funds. This project is currently set to be bid on November 17 by the NDDOT and will be placed on the next City Commission agenda for project creation.

Original Estimated Cost:
 \$1.35M

Original Estimated Revenues:
 \$625k Moorhead/MN Fed funds
 \$100k Fargo Park District
 \$250k ND Fed funds
 \$375k Special Assessments

Revised Estimated Cost:
 \$1.9M

Revised Estimated Revenues:
 \$900k Moorhead/MN Fed funds
 \$100k Fargo Park District
 \$250k ND Fed funds
 \$650k Sales Tax Funds

Recommended Motion

Approve the change in local funding from Special Assessments to Sales Tax Funds for Project QN-17-A1 - Oak Grove/Memorial Parks Pedestrian Lift Bridge Project.

JMG/klo

COVER SHEET
CITY OF FARGO PROJECTS

(23)

This sheet must be completed and turned in with all City of Fargo projects. NO items will be accepted by either the City Commission Office or the City Auditor's Office without this cover sheet attached and properly filled out.

Exact, full name of Project Number as it will appear in the Contract:

BRIDGE REMOVAL, GRADING, PAVING & NEW PEDESTRIAN LIFT BRIDGE

Project No. QN-17-A

Call For Bids October 23, 2017

Advertise Dates (by NDDOT) October 30 & November 6, 2017

Bid Opening Date (by NDDOT) November 17, 2017

Substantial Completion Date September 30, 2018

Final Completion Date October 30, 2018

N/A PWPEC Report (Part of 2017 CIP)

X Engineer's Report (Attach Copy)

N/A Direct City Auditor to Advertise for Bids (to be bid by ND DOT)

N/A Bid Quantities (Attach Copy for Auditor's Office Only)

N/A Notice to Property Owners (Dan Eberhardt)

Project Engineer Jeremy Gorden

Phone No. 241-1545

The items listed above are for use on all City projects. The additional items listed below are to be checked only when all or part of a project is to be special assessed:

N/A Create District (Attach Copy of Legal Description)

N/A Order Plans & Specifications

N/A Approve Plans & Specifications

N/A Adopt Resolution of Necessity

N/A Approve Escrow Agreement (Attach Copy for Commission Office Only)

N/A Assessment Map (Attach Copy for Auditor's Office Only)

ENGINEER'S REPORT

BRIDGE REMOVAL, GRADING, PAVING & NEW PEDESTRIAN LIFT BRIDGE

PROJECT NO. QN-17-A

Nature & Scope

This project will replace the existing Oak Grove/Memorial Parks pedestrian and bicycle bridge with a new pedestrian and bicycle lift bridge.

Purpose

The existing bridge, spanning the Red River, provides a critical link in the metropolitan non-motorized transportation system. Currently, the OG/M must be elevated each year by cranes because of spring flooding and heavy rains. This project replaces the 42-year old existing bridge with a bridge with a mechanical lift system, providing a more cost effective maintenance approach, minimizing bridge closure time, and reducing public infrastructure costs in the short and long-term period. The system improvement will minimize environmental (e.g., natural, social and economic) impacts, lower life cycle costs, enhance the regional multi-modal transportation system, and implement adopted community/transportation preservation plans, while creating a livable and sustainable environment that provides a long-term, multimodal, active-living solution to an ongoing metropolitan transportation issue.

The Cities of Fargo and Moorhead, the Fargo Park District, and Metro COG have planned for an extensive off-street system of shared use paths. This project is one that has been identified by all parties to move forward.

Feasibility

The estimated construction cost of this project is \$1,471,276. There are five funding sources; Federal Transportation Alternatives Program Funds (TAP) from both Minnesota and North Dakota, Fargo Park District Funds, Fargo Infrastructure Sales Tax Funds, and City of Moorhead local funds. The breakdowns are as follows:

Estimated Construction Cost:	\$ 1,471,276
Consultant Engineering Fees – Design and Construction Admin	<u>\$ 325,000</u>
Total Design and Construction	\$ 1,796,276

Split 50/50 between Minnesota side and North Dakota side

Minnesota Side

Costs:
 Construction & Consultant Engineering: \$ 898,138

Funding:
 TAP funds \$ 420,000
 Moorhead local funds \$ 478,138

Engineer's Report
Project No. QN-17-A
Page 2

North Dakota Side

Costs:

Construction & Consultant Engineering:	\$ 898,138
Plus Fees (on Fargo local funds (\$548,138))	
4% Engineering Oversight	\$ 21,925
7% Miscellaneous	\$ 38,369
4% Interest	\$ 21,925
Total	\$ 980,357

Funding:

TAP funds	\$ 250,000
Fargo Park District funds	\$ 100,000
Infrastructure Sales Tax funds	\$ 630,357

We believe this project to be cost effective.

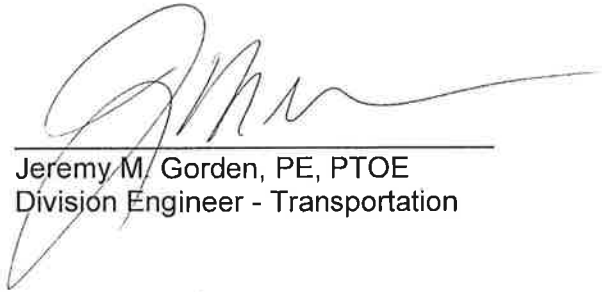

Jeremy M. Gorden, PE, PTOE
Division Engineer - Transportation

October 2017

24

MEMORANDUM

TO: BOARD OF CITY COMMISSIONERS

FROM: PLANNING DIRECTOR JIM GILMOUR *JG by MW*

DATE: OCTOBER 18, 2017

SUBJECT: Roberts Commons Parking Garage

Agreements to create the Roberts Commons condominium and establish bylaws for the condominium association were approved by the City Commission. Bylaws of the association create a four-person management board, with two members appointed by the City of Fargo.

After consultation with the City Administrator, we are recommending that the two members appointed by the City be City Auditor Steve Sprague, and Planner Derrick LaPoint.

RECOMMENDED MOTION: Appoint Steve Sprague and Derrick LaPoint to the Roberts Commons Condominium Board of Managers and approve the attached Joint Resolution of Owners and Board of Managers of Roberts Commons Condominium Association.



**JOINT RESOLUTION
OF
OWNERS
AND
BOARD OF MANAGERS
OF
ROBERTS COMMONS CONDOMINIUM ASSOCIATION**

THE UNDERSIGNED, being all of the Owners and Board of Managers of Roberts Commons Condominium Association, an unincorporated association (the "Association"), which Association was created pursuant to Declaration Establishing a Plan of Condominium Ownership dated October 13, 2017 ("Effective Date"), and the provisions of Chapter 47-04.1 of the North Dakota Century Code, hereby take the following actions as of the Effective Date; all capitalized terms used but not defined herein shall have the meanings ascribed to them in the Bylaws of the Association:

WHEREAS, the Bylaws of the Condominium state that the Board of Managers of the Condominium shall consist of four persons, two affiliated with and representing the Owner of each of the Wrap Unit and the Garage Unit;

WHEREAS, the Bylaws also state that the Board shall appoint the officers of the Association; and

NOW THEREFORE, BE IT RESOLVED AS OF THE EFFECTIVE DATE, THAT:

1. Appointment of two persons to the Board of Managers by the Owner of the Wrap Unit:

RESOLVED: That the following-named persons are hereby appointed to the Board of Managers of the Association, by the Owner of the Wrap Unit, to hold office until their respective successors are chosen and have qualified:

Mike Allmendinger

Bill Rothman

2. Appointment of two persons to the Board of Mangers by the Owner of the Garage Unit:

RESOLVED: That the following-named persons are hereby appointed to the Board of Managers of the Association, by the Owner of the Garage Unit, to hold office until their respective successors are chosen and have qualified:

Steve Sprague, City Auditor

Derrick LaPoint, City Planner

3. Officers Elected by Board of Managers:

RESOLVED: That the Board of Managers hereby elects the following-named persons to the offices of the Association set forth opposite their names below, to hold office until their respective successors are chosen and have qualified (hereinafter “Officers”):

President:	Derrick LaPoint
Vice President:	Mike Allmendinger
Secretary:	Bill Rothman
Treasurer:	Steve Sprague

This Resolution may be signed in any number of counterparts, all of which when taken together shall constitute one complete instrument. A facsimile, email or .pdf copy of a party’s signature shall be deemed a party’s original signature and shall bind such party as if it were the party’s original signature.

[The remainder of this page intentionally left blank – signature pages follow]

OWNER OF WRAP UNIT:

DFI ROBERTS LLC

By: _____

Bill Rothman, Vice President

OWNER OF GARAGE UNIT:

**CITY OF FARGO, a North Dakota
municipal corporation**

By: _____

Timothy J. Mahoney

Its: Mayor

ATTEST:

Steven Sprague, City Auditor

BOARD OF MANAGERS:

Mike Allmendinger

Bill Rothman

Derrick LaPoint

Steve Sprague

25

MEMORANDUM

TO: BOARD OF CITY COMMISSIONERS

FROM: PLANNING DIRECTOR JIM GILMOUR *JG*

DATE: OCTOBER 18, 2017

SUBJECT: 7305 South University Drive

The Finance Committee is recommending the purchase of 7305 South University Drive for \$250,000. The recommended source of money is the flood sales tax.

The property is one of six remaining houses along University between 70th Avenue South and 76th Avenue South. Most of the other houses were purchased by Cass County with a flood buyout program.

Planning staff has been working on a future land use plan for the property, which is in the flood plain. Creation of an area for community gardens and garden space appears to be a good use of the property.

The purchase and occupancy agreement are attached for your review.

RECOMMENDED MOTION: Approve the purchase agreement and occupancy agreement for 7305 South University Drive.



PURCHASE AGREEMENT

THIS AGREEMENT, made and entered into by and between **BENJAMIN PITZ and EMILY PITZ**, hereinafter "Seller" whether one or more, and the **CITY OF FARGO**, a North Dakota municipal corporation, hereinafter "City" or "Buyer",

WITNESSETH:

WHEREAS, Seller is the owner of real estate situated in the County of Cass and State of North Dakota described as follows:

Lot One (1), in Block Two (2), of Chrisan First Subdivision, a part of the Southeast Quarter of Section Twelve, in Township One Hundred Thirty-eight North of Range Forty-nine West of the Fifth Principal Meridian, situate in the County of Cass and the State of North Dakota.

(Address of said property is 7305 South University Drive, Fargo, North Dakota).

WHEREAS, Seller wishes to sell the property to Buyer, and Buyer agrees to purchase in accordance with the terms herein.

NOW, THEREFORE, in consideration of the mutual covenants, promises and agreements of the parties, it is hereby agreed as follows:

1. Subject Matter. The subject matter of this agreement is the real estate described, consisting of a single family dwelling, other buildings located thereon, and all items affixed to the property.
2. Purchase Price. The purchase price is Two Hundred Fifty Thousand Dollars (\$250,000).
3. Payment of Purchase Price. The mortgage, if any, as well as any liens or encumbrances, will be paid and Seller shall receive the balance of the purchase price, less any escrow amounts, in cash on the date of closing.
4. Salvage. Seller shall be allowed to remove from the personal items and appliances, limited to wood stove (properly capped), range, refrigerator, washer and dryer, so long as no structural damage occurs in the removal.
5. Abstract. Seller shall furnish Buyer an abstract of title to the subject property and Buyer shall pay for the cost of continuation of said abstract to a recent date. Said abstract must show good and marketable title in Seller free and clear of all liens and encumbrances (other than those that will be handled at closing).
6. Taxes and Utilities. Taxes and installments of special assessments for the year of closing shall be prorated between the parties to the date of closing based upon current total true value as calculated by the County of Cass, ND, as of the date of closing. Prior year taxes and

assessments must be paid by Seller in advance of closing.

7. Deed. Seller shall sign a warranty deed prepared by Buyer. Buyer will take title as follows: City of Fargo, North Dakota, a municipal corporation.

8. Closing Date and Transfer of Possession. Closing shall take place as soon as practicable. The City shall take possession of the real estate no later than the last day of the month of closing, unless other arrangements have been made. If City does not take possession on the date of closing, \$1,000 will be required of Seller at closing and retained until such time as the possession of the property is secured by the City in satisfactory condition. Seller agrees the \$1,000 deposit may be forfeited if the property is not delivered in satisfactory condition.

A separate Occupancy Agreement may be entered into between the parties should Seller desire to continue to reside in the dwelling longer than the end of the month of closing. If Seller elects to occupy the premises beyond the end of the month of closing, rent shall be paid to the City in the amount of \$800/month beginning on the 1st day of the month following closing. 2% of the purchase price shall be retained until such time Seller vacates the premises and remits the garage door openers and keys to the City.

If Seller vacates the property prior to closing, the end of the month of closing, or prior to the expiration of the time period contained in an Occupancy Agreement, Seller shall immediately notify Buyer so that appropriate measures can be taken to secure the premises.

9. Warranty. Seller provides no express warranties on the subject property. Buyer understands and agrees that the property is a used home and is being purchased "AS IS". Buyer shall make any inspection it deems necessary concerning the condition of said used home.

10. Inspection and Photographs. Seller agrees to allow City to enter the Premises for purposes of inspection, including but not limited to asbestos testing and mitigation.

DATED this 11 day of October, 2017.

SELLER:

Benjamin Pitz

Emily Pitz

DATED this ____ day of _____, 2017.

BUYER:
City of Fargo, a North Dakota
municipal corporation

Timothy J. Mahoney, Mayor

ATTEST:

Steve Sprague, City Auditor

OCCUPANCY AGREEMENT

THIS AGREEMENT, made by and between **BENJAMIN PITZ and EMILY PITZ**, hereinafter "Occupant" of the property located at 7305 South University Drive, Fargo, North Dakota, hereinafter "Premises", and the **CITY OF FARGO**, a North Dakota municipal corporation, hereinafter "City", as the Owner of said property,

1. City agrees to allow Occupant to remain in the Premises until May 31, 2018. Occupant shall remit to City rent in the amount of \$800 per month, commencing the first of the month following closing of the purchase of the Premises by the City. Delinquent rental payments may be deducted from the amount retained at closing.

2. In no event shall Occupant remain in possession of the Premises later than May 31, 2018, unless otherwise agreed to in writing signed by both parties. Notwithstanding the possession date contained in this agreement, Occupant agrees to allow City to enter the Premises for purposes of inspection and mitigation.

3. **Occupant shall furnish to the City a copy of a tenant's policy of insurance insuring against liability in at least the principal sum of \$500,000 per occurrence.** City shall be named as an additional insured on said policy. In addition, Occupant agrees to indemnify and hold City harmless from any and all claims, demands or causes of action that may be asserted as a result of Occupant's continued occupancy of the Premises. Occupant shall pay all utilities to the premises until they vacate the property.

4. Occupant is occupying the premises "as is". Accordingly, City shall not be responsible for any repairs of any kind. If the Premises should become uninhabitable, Occupant's sole remedy is to vacate the Premises. Notice must be immediately provided to City upon vacation.

5. Occupant agrees that City will not be responsible for security or protection of the occupied premises.

6. Occupant shall notify the City five (5) days prior to vacating the Premises. Vacation prior to the end of the term shall not result in a refund of rental amounts paid by Occupant.

Dated this 11 day of October, 2017.



Benjamin Pitz



Emily Pitz

Dated this _____ day of _____, 2017.

City of Fargo, a North Dakota
municipal corporation

Timothy J. Mahoney, Mayor

ATTEST:

Steve Sprague, City Auditor

(28)

October 12, 2017

200 3rd Street North
Fargo, North Dakota 58102
Phone: (701) 241-1545
Fax: (701) 241-8101
E-Mail: feng@cityoffargo.com

Board of City Commissioners
City of Fargo
200 North Third Street
Fargo, ND 58102

**Re: Memorandum of Offer to Landowner
Permanent Easement (Sanitary Sewer) - Project #UN-15-B1**

Dear Commissioners:

Enclosed and delivered to the City Commission office is an original Memorandum of Offer to Landowner document for the acquisition of a permanent easement in association with Project #UN-15-B1. Final purchase price has been reached and at this time we are requesting authorization from the Commission to proceed with the purchase. All land acquisition procedures have been followed and the City Engineer's office recommends purchase.

RECOMMENDED MOTION: I/we hereby move to approve and authorize purchase of a permanent easement from **Fred M. Hector, Jr.** in association with Project #UN-15-B1 and that the Mayor is instructed to execute the Memorandum of Offer to Landowner on behalf of the City of Fargo.

Please return a copy of the signed original.

Respectfully submitted,

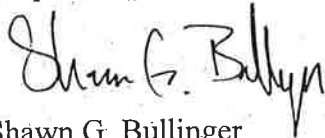

Shawn G. Bullinger
Land Acquisition Specialist

C: Nancy J. Morris
Mark Bittner

MEMORANDUM OF OFFER TO LANDOWNER

City of Fargo, Engineering Department

Project UN-15-B1	County Cass	Parcel(s) 64-0000-00590-000
Landowner Fred M. Hector, Jr.		
Mailing Address 6816 S. University Dr., Fargo, ND 58104		

The following-described real property and/or related temporary easement areas are being acquired for project purposes:

See attached exhibit(s).

I, as right of way agent for the City of Fargo, Engineering Department, am hereby authorized to offer the following amount of \$ 13,000.00 as full compensation for the fee and/or temporary taking of the foresaid parcels and all damages incidental thereto. The offer set forth has been established through one of the following, Basic Data Book, Certified Appraisal, City of Fargo Minimum Payment Policy. A breakdown of this offer is as follows:

Land	\$	
Easement and Access Control	\$	13,000.00
Improvements on Right of Way*	\$	
Damages to Remainder	\$	
Total Offer	\$	13,000.00

*Description of Damages to Remainder are as follows:

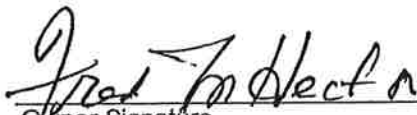
 Owner Signature
 Signature hereby constitutes acceptance of offer as presented above.

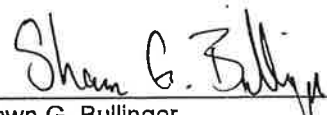
 Shawn G. Bullinger
 Land Acquisition Specialist, City of Fargo

Fargo City Commission has considered the offer and approves the same:



Timothy J. Mahoney
 MAYOR
 SIGNATURE
 DATE

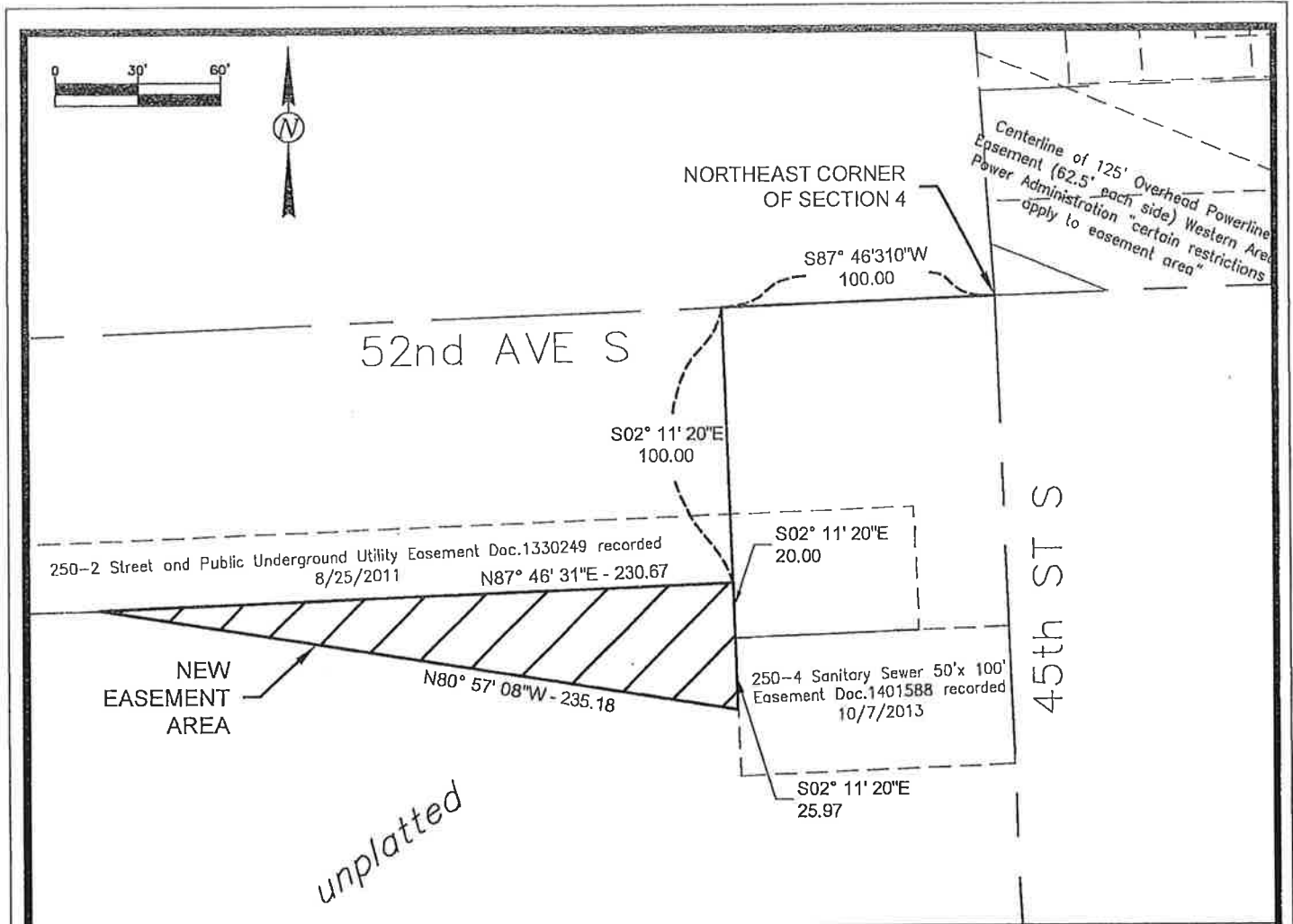

Exhibit A

 - New Sanitary Sewer Easement

Purpose: Permanent Sanitary Sewer Easement

Description:

A part of the Northeast Quarter of Section 4, Township 138 North, Range 49 West of the 5th Principal Meridian, Cass County, North Dakota, more fully described as:

Commencing at the northeast corner of said Section 4; thence South 87°46'31" West, along the north line of said Section 4, a distance of 100.00 feet; thence South 2°11'20" East, parallel to the east line of said Section 4, a distance of 100.00 feet to an angle point of a tract of land described by PERMANENT EASEMENT document 1330249 on file at the Cass County Recorder's Office, said point being the point of beginning; thence continuing South 2°11'20" East along a line as described in said document 1330249 a distance of 20.00 feet to the northwest corner of a tract of land described by PERMANENT EASEMENT document 1401588 on file at the Cass County Recorder's Office; thence continuing South 2°11'20" East along the west line of said tract described in document 1401588, a distance of 25.97 feet; thence North 80°57'09" West, a distance of 235.18 feet to a point on the south line of said tract described in document 1330249; thence North 87°46'31" East, along the south line of said tract described in document 1330249, a distance of 230.67 feet to the point of beginning.

Said tract contains 5302 square feet, more or less.

Bearings based on the City of Fargo ground control system.

 ENGINEERING DEPT.	PERMANENT SS EASEMENT	
	SANITARY SEWER TNSHP 138N, RANGE 49W, S4	
	DRAWN BY: MMW	DATE: MAY 2, 2017
	APPROVED BY: BHW	SHEET 1 OF 1

REPORT OF ACTION

29

PUBLIC WORKS PROJECTS EVALUATION COMMITTEE

Improvement District No. PR-17-B0
 NDDOT Projects IM-8-094(090)351 & NHS-8-081(039)925

Type: Contract Amendment #2

Location: University Drive– 18th Ave S to 21st Ave S

Date of Hearing: 10/16/2017

<u>Routing</u>	<u>Date</u>
City Commission	<u>10/23/2017</u>
PWPEC File	<u>X</u>
Project File	<u>Jeremy Gorden</u>

The Committee reviewed the accompanying correspondence from Division Engineer, Jeremy Gorden, related to Amendment #2 to Preliminary Engineering Reimbursement Agreement with NDDOT. NDDOT has the contract with Houston Engineering for this project but the City is responsible for 100% of the preliminary engineering costs. NDDOT has approved an additional \$103,630.08 in additional services for Houston. This will bring their total contract to \$366,896.63.

Staff is recommending approval.

On a motion by Mark Bittner, seconded by Ben Dow, the Committee voted to recommend approval of Contract Amendment #2.

RECOMMENDED MOTION

Concur with Contract Work Authorization Requests 3 through 7 from NDDOT and approve an additional \$103,630.08 for Improvement District No. PR-17-B0

PROJECT FINANCING INFORMATION:

Recommended source of funding for project: Sales Tax Funds, Special Assessments, Water Utility and Sewer Utility Funds

Developer meets City policy for payment of delinquent specials
 Agreement for payment of specials required of developer
 Letter of Credit required (per policy approved 5-28-13)

Yes	No
<u> </u>	<u> </u>
	N/A
	<u> </u>
	N/A
	<u> </u>
	N/A

COMMITTEE

Tim Mahoney, Mayor
 Jim Gilmour, Director of Planning
 Steve Dirksen, Fire Chief
 Mark Bittner, Director of Engineering
 Bruce Grubb, City Administrator
 Ben Dow, Director of Operations
 Steve Sprague, City Auditor
 City Engineer
 Kent Costin, Finance Director

	<u>Present</u>	<u>Yes</u>	<u>No</u>	<u>Unanimous</u>
	<input type="checkbox"/>	<input type="checkbox"/>	<input type="checkbox"/>	<u> </u>
	<input checked="" type="checkbox"/>	<input checked="" type="checkbox"/>	<input type="checkbox"/>	
	<input checked="" type="checkbox"/>	<input checked="" type="checkbox"/>	<input type="checkbox"/>	<u>Ryan Erickson</u>
	<input checked="" type="checkbox"/>	<input checked="" type="checkbox"/>	<input type="checkbox"/>	
	<input checked="" type="checkbox"/>	<input checked="" type="checkbox"/>	<input type="checkbox"/>	
	<input checked="" type="checkbox"/>	<input checked="" type="checkbox"/>	<input type="checkbox"/>	
	<input checked="" type="checkbox"/>	<input checked="" type="checkbox"/>	<input type="checkbox"/>	<u>Brenda Derrig</u>
	<input type="checkbox"/>	<input type="checkbox"/>	<input type="checkbox"/>	

ATTEST:

 Brenda E. Derrig, P.E.
 Division Engineer

C: Kristi Olson

Memo

October 11, 2017

To: PWPEC

From: Jeremy Gorden, P.E., PTOE *JMG*
 Division Engineer - Transportation

Subject: Amendment #2 to Preliminary Engineering Reimbursement Agreement with NDDOT
 South University Drive Street Reconstruction Project – 18th Avenue South to I-94 North
 Ramp and 21st Avenue South Intersection Improvements
 City of Fargo Improvement District No. PR-17-B0
 NDDOT Project No. IM-8-094(090)351

I have attached copies of all the "Contract Work Authorization Requests" from the NDDOT with regards to this project. NDDOT has the contract with Houston Engineering for this project but the City is responsible for 100% of the preliminary engineering costs. Houston Engineering, Inc. was selected by the NDDOT Selection Committee in June 2016. The original contract value was \$200,000 and we amended that amount to \$263,266.55 last December with Amendment #1.

Since last December, the NDDOT has approved an additional \$103,630.08 in additional services for Houston, and the additional tasks are associated with incorporating incentives and disincentives to the contract, revised traffic signal design, median improvements and storm sewer adjustments at the south ramp, modifications to the traffic report, additional work on the survey, street lighting redesign for the new pedestrian underpass, and additional driveway and sign relocations for a property just south of 18th Avenue South. The NDDOT Central Office Project Managers are very thorough and I fully support their decisions on contract matters.

Recommended Motion

Concur with "Contract Work Authorization Requests 3 through 7" and encumber an additional \$103,630.08 for this project.

JMG/jmg
 Attachments

CONTRACT WORK AUTHORIZATION REQUEST

North Dakota Department of Transportation, Environmental & Transportation Services
 SFN 60723 (Rev. 01-2015)

Work Authorization Number 1	Date 9/20/2016
--------------------------------	-------------------

PCN 21400	Project Number 8-081(039)925	Contract Number 19161465	
Consultant Houston Engineering, Inc.		Telephone Number (701) 237-5065	
Address 1401 21st Avenue North		City Fargo	State ND
		ZIP Code 58102	
Authorization Group Number 4	<input type="checkbox"/> Less than \$10,000 <input type="checkbox"/> \$10,000-\$50,000 <input type="checkbox"/> \$50,000-\$100,000 <input checked="" type="checkbox"/> Greater than \$100,000		
Original Contract Date 8/16/2016	Type of Work Preliminary Engineering for Phase II on Intersection Improvements		
Contract Total Maximum \$200,000.00	Authorization Increase Requested \$115,021.45	Contract Previously Authorized \$38,591.61	Total Authorized Amount To Date \$153,613.06

A contract work authorization is required because:

<p>1. Description of Work Phase II Preliminary Engineering Services. See attached scope and fee.</p>
<p>2. Justification: Work required for 106 compliance, public input meeting, environmental documentation, preliminary engineering, utility coordination and engineering, and design of right-of-way limits.</p>
<p>Detailed work activities, staffing, hours, fixed fee, expenses, and subconsultants attached: <input checked="" type="checkbox"/> Yes <input type="checkbox"/> No</p>

Labor Cost Increase Requested \$25,342.00	Indirect Rate % 1.7845	Indirect Labor Cost \$45,222.80	Total Labor Cost Requested \$70,564.80
Fixed Fee Rate % 0.120	Requested Total Labor x Fixed Fee Rate \$70,564.80		Total Fixed Fee Amount Requested \$8,467.78
DIRECT EXPENSES	RATE	UNITS	COSTS
Meals	\$30.00	2	\$60.00
Lodging			\$0.00
Mileage	\$0.5750	50	\$28.75
Supplies			\$0.00
GPS			\$0.00
Miscellaneous			\$0.00
FCCM	\$350.18	1	\$350.18
Printing	\$50.00	1	\$50.00
Sub Total			\$488.93
*SUBCONSULTANTS			
Juniper LLC	\$3,951.40	1	\$3,951.40
Benesch	\$23,671.82	1	\$23,671.82
Braun Intertec	\$7,876.72	1	\$7,876.72
			\$0.00
			\$0.00
			\$0.00
Sub Total			\$35,499.94
TOTAL			\$115,021.45

*Attach SFN 60233 Prime Consultant Request to Sublet. When adding subconsultants please coordinate with CAS to obtain indirect rate information.

Signature

Authorized Consultant <i>[Signature]</i>	Date 9/20/16	Division/District Technical Representative <input checked="" type="checkbox"/> Approval Recommended <input type="checkbox"/> Approved	Date 9-27-16
Contract Administrator <i>[Signature]</i>	Approval Recommended <input checked="" type="checkbox"/> Approved <input type="checkbox"/>		Date 9-28-16
Office Director	Approval <input checked="" type="checkbox"/>		Date 29 Sept 16

FINAL APPROVAL SIGNATURE REQUIRED BY WORK AUTHORIZATION GROUP:

GROUP	AUTHORIZATION APPROVAL LEVEL
1. Less than \$10,000	Designated Division or District Technical Representative
2. Equal to \$10,000-\$50,000	Contract Administrator - Division or District Engineer
3. Equal to \$50,000-\$100,000	Office Director
4. Greater than \$100,000	Office Director After Review with Deputy Director

NDDOT Distribution: Submit original copy to Environmental and Transportation Services, Consultant Administrative Services, one copy to Consultant, and project file.

**NORTH DAKOTA DEPARTMENT OF TRANSPORTATION
PE SUPPLEMENTARY AGREEMENT NO. 1**

CONSULTANT SERVICES PRELIMINARY ENGINEERING AGREEMENT

Project No. 8-081(039)925, PCN 21400

Location: FARGO UNIVERSITY DR(18TH AVE-I94 RAMPS

Length: 0.15 Miles

Type of Work: Preliminary Engineering for Phase I for Ramp and Pedestrian Improvements

THIS SUPPLEMENTARY AGREEMENT is entered into by and between Houston Engineering Inc., hereinafter known as the Engineer, whose address is 1401 21st Avenue North, Fargo, ND 58102, and the North Dakota Department of Transportation, hereinafter known as NDDOT, whose address is 608 East Boulevard Avenue, Bismarck, North Dakota 58505-0700.

WHEREAS, the **CONSULTANT SERVICES PRELIMINARY ENGINEERING AGREEMENT** approved by NDDOT on August 16, 2016, requires a supplemental agreement to the contract to address added work requested by the City of Fargo and NDDOT as part of the field review meeting. The changes require additional work for the following: Documented CATEX, Planning and Environmental:

- **21st Ave. S Improvements:** Replace the ADA ramps on the west side of University Drive at 21st Ave. S. Previously only the east side was included in the scope of work.
- **Traffic Data and Traffic Operations – Evaluate Incentive/Disincentive:** The City requested to use an Incentive/Disincentive as part of this project due to the high volume of traffic and potential ramifications if the project isn't completed during the summer months when school isn't in session. This will require evaluation into the user costs associated with the project being delayed.
- **Improvements to University Drive Underpass:** Replace all shared use path concrete up to the bridge from the north and south within the NDDOT R/W. It was determined at the field review that the path concrete is in very poor condition and will warrant replacement. Additional time will be required to estimate costs and draft replacement details. In addition, the existing shared use path rail beneath the interstate bridge will need to be evaluated for compliance with ADA standards and replaced if found to be out of compliance. The slope protection, median paving, and curb and gutter under the bridge may also be replaced due to poor condition. Additional time to design and estimate costs will be required.

NDDOT requested the work to be completed.

These activities are identified in Appendix C, dated September 22, 2016, attached and incorporated herein.

THEREFORE, NDDOT and the Engineer agree that the amount payable under the terms of the original agreement will be modified as follows:

The contract total maximum amount payable for this contract shall be increased \$63,266.55 from \$200,000.00 to \$263,266.55

The fixed fee shall be increased \$6,467.95 from \$2,727.25 to \$9,195.20.

THIS SUPPLEMENTARY AGREEMENT is effective from the date of the Director's signature. The original Consultant Services Preliminary Engineering agreement was based on the selection requirements in NDCC section 54-44.7-03 and NDDOT request for Proposal issued for this project.



All other terms and conditions of the above-referenced CONSULTANT SERVICES PRELIMINARY ENGINEERING AGREEMENT and any supplementary agreements thereto, are incorporated by reference, herein, and remain in full force and effect.

WITNESS:

Adam R Walker
NAME (TYPE OR PRINT)
Adam R Walker
SIGNATURE

ENGINEER:

Jeremy McLaughlin
NAME (TYPE OR PRINT)
Jeremy McLaughlin
SIGNATURE
VP
TITLE
9/27/16
DATE

To be signed by Owner; Partner; Corp. Pres., Vice Pres., or other authorized Corp. Officer. (If signed by other authorized Corp. Officer, please attach copy of Power of Attorney or other documentation showing authority to sign.)

APPROVED as to substance by:

MARK GAYDOS
DIVISION ENGINEER (TYPE OR PRINT)
Mark Gaydos
SIGNATURE
10/3/16
DATE

NORTH DAKOTA
DEPARTMENT OF TRANSPORTATION
Darcy R. Rosendahl
DEPUTY DIRECTOR FOR BUSINESS SUPPORT (TYPE OR PRINT)
Darcy R. Rosendahl
SIGNATURE
04OCT2016
DATE

CLA 52445 (Div. 19)
L.D. Approved 4-10-00; 03-16
RM Consulted 4-10-00



CONTRACT WORK AUTHORIZATION REQUEST

North Dakota Department of Transportation, Environmental & Transportation Services
SFN 60723 (Rev. 01-2015)

Work Authorization Number 2	Date 10/12/2016
--------------------------------	--------------------

PCN 21400	Project Number 8-081(039)925	Contract Number 19161465	
Consultant Houston Engineering, Inc.		Telephone Number (701) 237-5065	
Address 1401 21st Avenue North		City Fargo	State ND
		ZIP Code 58102	
Authorization Group Number 3	<input type="checkbox"/> Less than \$10,000 <input type="checkbox"/> \$10,000-\$50,000 <input checked="" type="checkbox"/> \$50,000-\$100,000 <input type="checkbox"/> Greater than \$100,000		
Original Contract Date 8/16/2016	Type of Work Preliminary Engineering for Phase II on Intersection Improvements		
Contract Total Maximum \$263,266.55	Authorization Increase Requested \$63,266.55	Contract Previously Authorized \$153,613.06	Total Authorized Amount To Date \$216,879.61



A contract work authorization is required because:

<p>1. Description of Work</p> <p>Phase II Preliminary Engineering Services associated with Supplement #1.</p> <p>The contract maximum increased per Supplement #1 from \$200,000.00 to \$263,266.55. WAR No. 2 is requesting authorization for the amount of Supplement #1.</p>
<p>2. Justification:</p> <p>Additional work associated with 21st Ave Improvements, shared use path replacement, curb replacements, median paving, and revisions to cost splits between PCN 21169 and PCN 21400 per Supplement #1.</p>
<p>Detailed work activities, staffing, hours, fixed fee, expenses, and subconsultants attached: <input type="checkbox"/> Yes <input checked="" type="checkbox"/> No</p>

Labor Cost Increase Requested \$19,357.00	Indirect Rate % 1.7845	Indirect Labor Cost \$34,542.57	Total Labor Cost Requested \$53,899.57
Fixed Fee Rate % 0.120	Requested Total Labor x Fixed Fee Rate \$53,899.57		Total Fixed Fee Amount Requested \$6,467.95
DIRECT EXPENSES	RATE	UNITS	COSTS
Meals			\$0.00
Lodging			\$0.00
Mileage			\$0.00
Supplies			\$0.00
GPS			\$0.00
Miscellaneous			\$0.00
FCCM	\$268.51	1	\$268.51
Printing	\$50.00	1	\$50.00
Sub Total			\$318.51
*SUBCONSULTANTS			
Prairie Soils Consulting	-\$1,630.75	1	-\$1,630.75
Benesch	\$4,211.28	1	\$4,211.28
			\$0.00
			\$0.00
			\$0.00
			\$0.00
Sub Total			\$2,580.53
TOTAL			\$63,266.56

*Attach SFN 60233 Prime Consultant Request to Sublet. When adding subconsultants please coordinate with CAS to obtain indirect rate information.

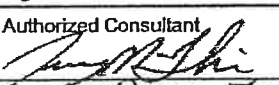
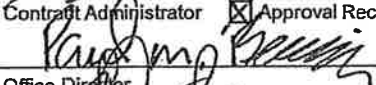
Signature

Authorized Consultant 	Date 10/21/16	Division/District Technical Representative <input checked="" type="checkbox"/> Approval Recommended <input type="checkbox"/> Approved	Date 10-24-16
Contract Administrator 	<input checked="" type="checkbox"/> Approval Recommended <input type="checkbox"/> Approved		Date
Office Director 	<input checked="" type="checkbox"/> Approved		Date 10/25/16

FINAL APPROVAL SIGNATURE REQUIRED BY WORK AUTHORIZATION GROUP:

GROUP	AUTHORIZATION APPROVAL LEVEL
1. Less than \$10,000	Designated Division or District Technical Representative
2. Equal to \$10,000-\$50,000	Contract Administrator - Division or District Engineer
3. Equal to \$50,000-\$100,000	Office Director
4. Greater than \$100,000	Office Director After Review with Deputy Director

NDDOT Distribution: Submit original copy to Environmental and Transportation Services, Consultant Administrative Services, one copy to Consultant, and project file.

NDDOT Contract No. 19161465B

**NORTH DAKOTA DEPARTMENT OF TRANSPORTATION
PE SUPPLEMENTARY AGREEMENT NO. 2**

CONSULTANT SERVICES PRELIMINARY ENGINEERING AGREEMENT

Project No. 8-081(039)925, PCN 21400

Location: FGO UNIVERSITY DR(18TH AVE-194 RAMPS

Length: 0.15 Miles

Type of Work: Preliminary Engineering for Phase I for Ramp and Pedestrian Improvements

THIS SUPPLEMENTARY AGREEMENT is entered into by and between Houston Engineering Inc., hereinafter known as the Engineer, whose address is 1401 21st Avenue North, Fargo, ND 58102, and the North Dakota Department of Transportation, hereinafter known as NDDOT, whose address is 608 East Boulevard Avenue, Bismarck, North Dakota 58505-0700.

WHEREAS, the **CONSULTANT SERVICES PRELIMINARY ENGINEERING AGREEMENT** approved by NDDOT on August 16, 2016, requires a supplemental agreement to the contract for anticipated design modifications to the Fargo University Drive reconstruction project. The approximate project construction limits are from south of 18th Ave S. to the south side of 21st Ave S. This work also includes 21st Ave S improvements for pedestrian connectivity on the east side of University Drive. NDDOT requested this work to be completed.

THEREFORE, NDDOT and the Engineer agree that the amount payable under the terms of the original agreement will be modified as follows:

The contract total maximum cost for this agreement shall be increased \$77,886.63 from \$263,266.55 to \$341,153.18

THIS SUPPLEMENTARY AGREEMENT is effective from the date of the Director's signature. The original Consultant Services Preliminary Engineering agreement was based on the selection requirements in NDCC section 54-44.7-03 and NDDOT request for Proposal issued for this project.



All other terms and conditions of the above-referenced **CONSULTANT SERVICES PRELIMINARY ENGINEERING AGREEMENT** and any supplementary agreements thereto, are incorporated by reference, herein, and remain in full force and effect.

WITNESS:

Nancy E. Wills
NAME (TYPE OR PRINT)
Nancy E. Wills
SIGNATURE

ENGINEER:

JEREMY McLaughlin
NAME (TYPE OR PRINT)
Jeremy McLaughlin
SIGNATURE
VP
TITLE
3/9/17
DATE

To be signed by Owner; Partner; Corp. Pres., Vice Pres., or other authorized Corp. Officer. (If signed by other authorized Corp. Officer, please attach copy of Power of Attorney or other documentation showing authority to sign.)

APPROVED as to substance by:

MARIA GAYDOS
DIVISION ENGINEER (TYPE OR PRINT)
[Signature]
SIGNATURE
3/13/17
DATE

NORTH DAKOTA
DEPARTMENT OF TRANSPORTATION
Darcy R. Rosendahl
DEPUTY DIRECTOR FOR BUSINESS SUPPORT (TYPE OR PRINT)
Darcy R. Rosendahl
SIGNATURE
15 MAR 2017
DATE

CLA 52445 (Div. 19)
L.D. Approved 4-10-00; 03-16
RM Consulted 4-10-00

APPROVED as to execution this
14 day of March 2017
ATTORNEY GENERAL
By [Signature]
SPECIAL ASST. ATTORNEY GENERAL

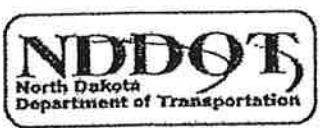

CONTRACT WORK AUTHORIZATION REQUEST

North Dakota Department of Transportation, Environmental & Transportation Services
 SFN 60723 (Rev. 01-2015)

Work Authorization Number 3	Date 1/25/2017
--------------------------------	-------------------

PCN 21400	Project Number 8-081(039)924	Contract Number 19161465	
Consultant Houston Engineering, Inc.		Telephone Number (701) 237-5065	
Address 1401 21st Avenue North		City Fargo	State ND
ZIP Code 58102			
Authorization Group Number 1	<input checked="" type="checkbox"/> Less than \$10,000 <input type="checkbox"/> \$10,000-\$50,000 <input type="checkbox"/> \$50,000-\$100,000 <input type="checkbox"/> Greater than \$100,000		
Original Contract Date 8/16/2016	Type of Work Preliminary Engineering for Phase II on Intersection Improvements		
Contract Total Maximum \$263,266.55	Authorization Increase Requested \$0.00	Contract Previously Authorized \$216,879.61	Total Authorized Amount To Date \$216,879.61

A contract work authorization is required because:

1. Description of Work

Phase II Preliminary Engineering Services associated with University Drive Reconstruction. Incentive/Disincentive study to be added to the Traffic Operations Report and Documented CatEx.

2. Justification:

This item is outside of the original scope of work for the Traffic Operations Report and Documented CatEX. A no cost WAR is requested at this time, however a supplemental agreement may be needed at a later time. Estimated cost of the Incentive/Disincentive Study is \$4,000.

Detailed work activities, staffing, hours, fixed fee, expenses, and subconsultants attached: Yes No

**NORTH DAKOTA DEPARTMENT OF TRANSPORTATION
PE SUPPLEMENTARY AGREEMENT NO. 3**

CONSULTANT SERVICES PRELIMINARY ENGINEERING AGREEMENT

Project No. 8-081(039)925, PCN 21400

Location: FGO UNIVERSITY DR(18TH AVE-I94 RAMPS

Length: 0.15 Miles

Type of Work: Preliminary Engineering for Phase I for Ramp and Pedestrian Improvements

THIS SUPPLEMENTARY AGREEMENT is entered into by and between Houston Engineering Inc., hereinafter known as the Engineer, whose address is 1401 21st Avenue North, Fargo, ND 58102, and the North Dakota Department of Transportation, hereinafter known as NDDOT, whose address is 608 East Boulevard Avenue, Bismarck, North Dakota 58505-0700.

WHEREAS, the **CONSULTANT SERVICES PRELIMINARY ENGINEERING AGREEMENT** approved by NDDOT on August 16, 2016, requires a supplemental agreement to the contract because of the following additional work is needed pertaining to the aerial & field survey, lighting and driveway & sign relocation.

- * Photogrammetry sub-consultant, Martinez Geospatial, experienced difficulty resolving disagreements between aerial imagery and ground truthing data. As a solution, Martinez utilized Leica P20 and P40 scanners to create a survey grade 3-D model within ROW.
- * This work was approved as no-cost WAR IV.
- * HEI's cost: \$716.44; HEI's Hours: 8
- * Work Approved WAR IV

After the I-94 Westbound On-Ramp pedestrian underpass was selected as an optional work item from the Documented CatEx (DCE), the City of Fargo requested lighting for the pedestrian path. Pedestrian path lighting was not included in the original scope. HEI's sub-consultant Benesch will review the need for pedestrian path lighting based upon new high mast information made available by NDDOT. Benesch will design the pedestrian path lighting (per the City's request).

- * This work was approved as no-cost WAR VI.
- * HEI's cost: \$1,027.54; HEI's Hours: 8
- * Work Approved WAR VI

After pedestrian underpass lift station was selected in the DCE, NDDOT requested additional hydraulic analysis on the existing University Drive lift station. In addition to the preliminary analysis provided in the DCE, analysis of two additional alternatives were provided. HEI held one preliminary phone meeting with NDDOT to discuss the Hydraulic Report comments and one teleconference meeting with NDDOT and the City of Fargo to review and discuss the alternatives. It was determined that a full study of the drainage from I-29 to the Red River would be required and that this would be done in a separate project.

- * HEI's cost: \$9,655.11; HEI's Hours: 72
- * Total Requested for Task: \$9,655.11

The original scope of the Incentive/Disincentive (I/D) Memorandum did not include coordination meetings with NDDOT and the City of Fargo. HEI held two meetings at the request of the City and NDDOT to facilitate discussion I/D. HEI will write a separate recommendations memo after a construction schedule has been created. The independent recommendations memo will be included in the appendix to the Contract Time for Completion Summary along with the Incentive/Disincentive Memorandum.

Additionally, time is also needed to incorporate the DTM into a merged surface. Additional effort was required after WAR IV to perform additional field survey to verify data and merge surveys.

During a meeting with the City of Fargo, the relocation of the US Bank driveway to the south was approved. Relocation of the driveway places it behind the University drive median barrier, effectively making it a right-in right-out driveway. As part of this relocation, two US Bank signs will need to be moved. Additional hours are needed for the driveway and sign relocations.

- * HEI's cost: \$14,344.36; HEI's Hours: 140

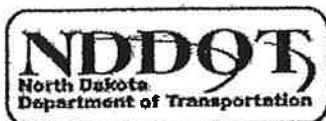

* Total Requested for Task: \$14,344.36.

THEREFORE, NDDOT and the Engineer agree that the amount payable under the terms of the original agreement will be modified as follows:

The contract total maximum cost for this agreement shall be increased \$25,743.45 from \$341,153.18 to \$366,896.63

THIS SUPPLEMENTARY AGREEMENT is effective from the date of the Director's signature. The original Consultant Services Preliminary Engineering agreement was based on the selection requirements in NDCC section 54-44.7-03 and NDDOT request for Proposal issued for this project.



All other terms and conditions of the above-referenced **CONSULTANT SERVICES PRELIMINARY ENGINEERING AGREEMENT** and any supplementary agreements thereto, are incorporated by reference, herein, and remain in full force and effect.

WITNESS:

Sara Hoffman

NAME (TYPE OR PRINT)

Sara Hoffman

SIGNATURE

ENGINEER:

Jeremy McLaughlin

NAME (TYPE OR PRINT)

Jeremy McLaughlin

SIGNATURE

UP

TITLE

7/18/17

DATE

To be signed by Owner; Partner; Corp. Pres., Vice Pres., or other authorized Corp. Officer. (If signed by other authorized Corp. Officer, please attach copy of Power of Attorney or other documentation showing authority to sign.)

APPROVED as to substance by:

MARK GAYNES

DIVISION ENGINEER (TYPE OR PRINT)

Mark Gaynes

SIGNATURE

7/24/17

DATE

NORTH DAKOTA
DEPARTMENT OF TRANSPORTATION

RONALD J. HENKE

SO¹ DEPUTY DIRECTOR FOR BUSINESS SUPPORT (TYPE OR PRINT)

Ronald J. Henke

SIGNATURE

7/26/17

DATE

CLA 52445 (Div. 19)
L.D. Approved 4-10-00; 03-16
RM Consulted 4-10-00

APPROVED as to execution this
26 day of July 20 17
ATTORNEY GENERAL
By *Debra J. J...*
SPECIAL ASST. ATTORNEY GENERAL

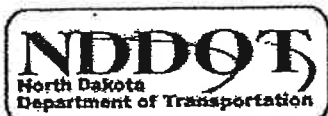

CONTRACT WORK AUTHORIZATION REQUEST

North Dakota Department of Transportation, Environmental & Transportation Services
 SFN 60723 (Rev. 01-2015)

Work Authorization Number 4	Date 3/18/2017
--------------------------------	-------------------

PCN 21400	Project Number 8-081(039)924	Contract Number 19161465	
Consultant Houston Engineering, Inc.		Telephone Number (701) 237-5065	
Address 1401 21st Avenue North		City Fargo	State ND
ZIP Code 58102			
Authorization Group Number 1	<input checked="" type="checkbox"/> Less than \$10,000 <input type="checkbox"/> \$10,000-\$50,000 <input type="checkbox"/> \$50,000-\$100,000 <input type="checkbox"/> Greater than \$100,000		
Original Contract Date 8/16/2016	Type of Work Phase II Final Design For FGO University Dr (18th Ave I-94 Ramps)		
Contract Total Maximum \$341,153.18	Authorization Increase Requested \$0.00	Contract Previously Authorized \$216,879.61	Total Authorized Amount To Date \$216,879.61

A contract work authorization is required because:

1. Description of Work
 Phase I - Preliminary Survey

2. Justification:

This item is outside of the original scope of work for the Phase I Survey Task. Martinez will perform laser scanning services using Leica P20 and P40 scanners due to issues that arose during the aerial/photogrammetry process. A no cost WAR is requested at this time, however a supplemental agreement may be needed at a later time. The estimated cost for Martinez efforts and HEI coordination is approximately \$6,000 in total. (\$3,000 for PCN 21169 and \$3,000 for PCN 21400)

Detailed work activities, staffing, hours, fixed fee, expenses, and subconsultants attached: Yes No

Labor Cost Increase Requested	Indirect Rate % 1.7845	Indirect Labor Cost \$0.00	Total Labor Cost Requested \$0.00
Fixed Fee Rate % 0.120	Requested Total Labor x Fixed Fee Rate \$0.00		Total Fixed Fee Amount Requested \$0.00
DIRECT EXPENSES	RATE	UNITS	COSTS
Meals			\$0.00
Lodging			\$0.00
Mileage			\$0.00
Supplies			\$0.00
GPS			\$0.00
Miscellaneous			\$0.00
			\$0.00
			\$0.00
		Sub Total	\$0.00
*SUBCONSULTANTS			
			\$0.00
			\$0.00
			\$0.00
			\$0.00
			\$0.00
			\$0.00
		Sub Total	\$0.00
		TOTAL	\$0.00

*Attach SFN 60233 Prime Consultant Request to Sublet. When adding subconsultants please coordinate with CAS to obtain indirect rate information.

Signature

Authorized Consultant <i>Nancy E. Wells</i>	Date 3/18/17	Division/District Technical Representative <i>Michael J. ...</i>	<input type="checkbox"/> Approval Recommended <input checked="" type="checkbox"/> Approved	Date 3-21-17
Contract Administrator	<input type="checkbox"/> Approval Recommended	<input type="checkbox"/> Approved		Date
Office Director	<input type="checkbox"/> Approved			Date

FINAL APPROVAL SIGNATURE REQUIRED BY WORK AUTHORIZATION GROUP:

GROUP	AUTHORIZATION APPROVAL LEVEL
1. Less than \$10,000	Designated Division or District Technical Representative
2. Equal to \$10,000-\$50,000	Contract Administrator - Division or District Engineer
3. Equal to \$50,000-\$100,000	Office Director
4. Greater than \$100,000	Office Director After Review with Deputy Director

NDDOT Distribution: Submit original copy to Environmental and Transportation Services, Consultant Administrative Services, one copy to Consultant, and project file.

CONTRACT WORK AUTHORIZATION REQUEST

North Dakota Department of Transportation, Environmental & Transportation Services
 SFN 60723 (Rev. 01-2015)

Work Authorization Number 5	Date 4/3/2017
--------------------------------	------------------

PCN 21400	Project Number 8-081(039)924	Contract Number 19161465	
Consultant Houston Engineering, Inc.		Telephone Number (701) 237-5065	
Address 1401 21st Avenue North		City Fargo	State ND
ZIP Code 58102			
Authorization Group Number 4	<input type="checkbox"/> Less than \$10,000 <input type="checkbox"/> \$10,000-\$50,000 <input type="checkbox"/> \$50,000-\$100,000 <input checked="" type="checkbox"/> Greater than \$100,000		
Original Contract Date 8/16/2016	Type of Work Phase II Final Design For FGO University Dr (18th Ave I-94 Ramps)		
Contract Total Maximum \$341,153.18	Authorization Increase Requested \$122,622.20	Contract Previously Authorized \$216,879.61	Total Authorized Amount To Date \$339,501.81

A contract work authorization is required because:

<p>1. Description of Work Phase III Final Design. (Scope and Fee attached.)</p>
<p>2. Justification: Final Design of the University Drive (Business US 81) Reconstruction project from the north I-94 ramps to 18th Ave S in Fargo, ND.</p>
Detailed work activities, staffing, hours, fixed fee, expenses, and subconsultants attached: <input checked="" type="checkbox"/> Yes <input type="checkbox"/> No

Labor Cost Increase Requested \$27,967.00	Indirect Rate % 1.7845	Indirect Labor Cost \$49,907.11	Total Labor Cost Requested \$77,874.11
Fixed Fee Rate % 0.120	Requested Total Labor x Fixed Fee Rate \$77,874.11		Total Fixed Fee Amount Requested \$9,344.89
DIRECT EXPENSES	RATE	UNITS	COSTS
Meals			\$0.00
Lodging			\$0.00
Mileage	\$0.5750	88	\$50.60
Supplies			\$0.00
GPS			\$0.00
Miscellaneous	\$325.00	1	\$325.00
FCCM	\$388.84	1	\$388.84
Deduct Remain Phase I & II	-\$38,000.00	1	-\$38,000.00
		Sub Total	-\$37,235.56
*SUBCONSULTANTS			
Benesch	\$52,976.01	1	\$52,976.01
Jorge Pagan	\$10,000.00	1	\$10,000.00
NEXgen	\$9,702.75	1	\$9,702.75
			\$0.00
			\$0.00
			\$0.00
		Sub Total	\$72,678.76
		TOTAL	\$122,662.20

*Attach SFN 60233 Prime Consultant Request to Sublet. When adding subconsultants please coordinate with CAS to obtain indirect rate information.

Signature

Authorized Consultant <i>[Signature]</i>	Date 4/13/17	Division/District Technical Representative <i>[Signature]</i>	<input checked="" type="checkbox"/> Approval Recommended <input type="checkbox"/> Approved	Date 4-7-17 <i>[Signature]</i>
Contract Administrator <i>[Signature]</i>	<input checked="" type="checkbox"/> Approval Recommended <input type="checkbox"/> Approved			Date 4-7-17
Office Director <i>[Signature]</i>	<input checked="" type="checkbox"/> Approved			Date 4-10-17

FINAL APPROVAL SIGNATURE REQUIRED BY WORK AUTHORIZATION GROUP:

GROUP	AUTHORIZATION APPROVAL LEVEL
1. Less than \$10,000	Designated Division or District Technical Representative
2. Equal to \$10,000-\$50,000	Contract Administrator - Division or District Engineer
3. Equal to \$50,000-\$100,000	Office Director
4. Greater than \$100,000	Office Director After Review with Deputy Director

NDDOT Distribution: Submit original copy to Environmental and Transportation Services, Consultant Administrative Services, one copy to Consultant, and project file.

CONTRACT WORK AUTHORIZATION REQUEST

North Dakota Department of Transportation, Environmental & Transportation Services
 SFN 60723 (Rev. 01-2015)

Work Authorization Number 6	Date 5/18/2017
--------------------------------	-------------------

PCN 21400	Project Number 8-081(039)924	Contract Number 19161465	
Consultant Houston Engineering, Inc.		Telephone Number (701) 237-5065	
Address 1401 21st Avenue North	City Fargo	State ND	ZIP Code 58102
Authorization Group Number 1	<input checked="" type="checkbox"/> Less than \$10,000 <input type="checkbox"/> \$10,000-\$50,000 <input type="checkbox"/> \$50,000-\$100,000 <input type="checkbox"/> Greater than \$100,000		
Original Contract Date 8/16/2016	Type of Work Phase II Final Design For FGO University Dr (18th Ave I-94 Ramps)		
Contract Total Maximum \$341,153.18	Authorization Increase Requested \$0.00	Contract Previously Authorized \$339,501.81	Total Authorized Amount To Date \$339,501.81

A contract work authorization is required because:

1. Description of Work
 Phase III Final Design.

2. Justification:

The City of Fargo has requested additional analysis of past incentive/disincentive projects. Benesch will review past projects utilizing incentives and disincentives write a synopsis for inclusion in the Incentive/Disincentive memorandum. The estimated cost for this I/D revision is \$3,500. Additionally, the City has requested pedestrian lighting to and from the pedestrian underpass at the I-94 westbound on-ramp (optional work item). The estimated cost of designing the pedestrian lighting is \$7,500. HEI is requesting a no-cost work authorization, however a supplemental agreement may be needed at a later time. The total estimated cost for Benesch and HEI's coordination is \$11,000.

Detailed work activities, staffing, hours, fixed fee, expenses, and subconsultants attached: Yes No

Labor Cost Increase Requested	Indirect Rate %	Indirect Labor Cost	Total Labor Cost Requested
\$0.00		\$0.00	\$0.00
Fixed Fee Rate %	Requested Total Labor x Fixed Fee Rate		Total Fixed Fee Amount Requested
0.120	\$0.00		\$0.00
DIRECT EXPENSES	RATE	UNITS	COSTS
Meals			\$0.00
Lodging			\$0.00
Mileage			\$0.00
Supplies			\$0.00
GPS			\$0.00
Miscellaneous			\$0.00
			\$0.00
			\$0.00
		Sub Total	\$0.00
*SUBCONSULTANTS			
			\$0.00
			\$0.00
			\$0.00
			\$0.00
			\$0.00
			\$0.00
		Sub Total	\$0.00
		TOTAL	\$0.00

*Attach SFN 60233 Prime Consultant Request to Sublet. When adding subconsultants please coordinate with CAS to obtain indirect rate information.

Signature

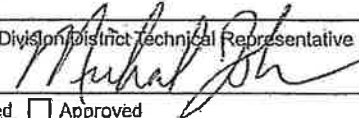
Authorized Consultant	Date	Division/District Technical Representative	<input type="checkbox"/> Approval Recommended	<input checked="" type="checkbox"/> Approved	Date
	6/18/17				6-8-17
Contract Administrator	<input type="checkbox"/> Approval Recommended	<input type="checkbox"/> Approved			Date
Office Director		<input type="checkbox"/> Approved			Date

FINAL APPROVAL SIGNATURE REQUIRED BY WORK AUTHORIZATION GROUP:

GROUP	AUTHORIZATION APPROVAL LEVEL
1. Less than \$10,000	Designated Division or District Technical Representative
2. Equal to \$10,000-\$50,000	Contract Administrator - Division or District Engineer
3. Equal to \$50,000-\$100,000	Office Director
4. Greater than \$100,000	Office Director After Review with Deputy Director

NDDOT Distribution: Submit original copy to Environmental and Transportation Services, Consultant Administrative Services, one copy to Consultant, and project file.

CONTRACT WORK AUTHORIZATION REQUEST

North Dakota Department of Transportation, Environmental & Transportation Services
 SFN 60723 (Rev. 01-2015)

Work Authorization Number 7	Date 7/28/2017
--------------------------------	-------------------

PCN 21400	Project Number 8-081(039)924	Contract Number 19161465	
Consultant Houston Engineering, Inc.		Telephone Number (701) 237-5065	
Address 1401 21st Avenue North	City Fargo	State ND	ZIP Code 58102
Authorization Group Number 2	<input type="checkbox"/> Less than \$10,000 <input checked="" type="checkbox"/> \$10,000-\$50,000 <input type="checkbox"/> \$50,000-\$100,000 <input type="checkbox"/> Greater than \$100,000		
Original Contract Date 8/16/2016	Type of Work Phase II Final Design For FGO University Dr (18th Ave I-94 Ramps)		
Contract Total Maximum \$366,896.63	Authorization Increase Requested \$27,394.82	Contract Previously Authorized \$339,501.81	Total Authorized Amount To Date \$366,896.63

A contract work authorization is required because:

1. Description of Work

Work associated with no-cost WARs 4 and 6, and addition efforts associated with incentive/disincentive, US Bank sign relocations, and survey above the level defined in WAR 4. A summary is included in the letter "Request for Maximum Contract Adjustment Increase" dated 7-11-17.

2. Justification:

Significant additional effort was required after WAR #4 to perform field survey to verify data from Martinez and merge the surfaces. This work was approved as no-cost WAR #4. HEI's cost: \$716.44; HEI's Hours: 8

After the I-94 Westbound On-Ramp pedestrian underpass was selected as an optional work item from the Documented CatEx (DCE), the City of Fargo requested lighting for the pedestrian path. This work was approved as no-cost WAR #6. HEI's cost: \$1,027.54; HEI's Hours: 8

After the DCE was signed, NDDOT requested preliminary hydraulic analysis of the University Drive lift for two additional alternatives. HEI's cost: \$9,655.11; HEI's Hours: 72

Additional survey to tie-in Martinez DTMs: HEI's cost: \$10,397.11; HEI's Hours: 111. Meetings with NDDOT and the City were required for incentive and disincentive discussion and separate memo. HEI's cost: \$3,947.25; HEI's Hours: 29

The contract balance of \$1,651.37 for Phase IV Engineer of Record is also requested at this time.

Detailed work activities, staffing, hours, fixed fee, expenses, and subconsultants attached: Yes No

Labor Cost Increase Requested \$8,724.00	Indirect Rate % 1.7845	Indirect Labor Cost \$15,567.98	Total Labor Cost Requested \$24,291.98
Fixed Fee Rate % 0.120	Requested Total Labor x Fixed Fee Rate \$24,291.98		Total Fixed Fee Amount Requested \$2,915.04
DIRECT EXPENSES	RATE	UNITS	COSTS
Meals			\$0.00
Lodging			\$0.00
Mileage	\$0.7300	10	\$7.30
Supplies			\$0.00
GPS	\$15.00	3	\$45.00
Miscellaneous	\$13.55	1	\$13.55
FCCM	\$121.95	1	\$121.95
			\$0.00
Sub Total			\$187.80
*SUBCONSULTANTS			
			\$0.00
			\$0.00
			\$0.00
			\$0.00
			\$0.00
			\$0.00
Sub Total			\$0.00
TOTAL			\$27,394.82

*Attach SFN 60233 Prime Consultant Request to Sublet. When adding subconsultants please coordinate with CAS to obtain indirect rate information.

Signature

Authorized Consultant <i>[Signature]</i>	Date 7/20/17	Division/District Technical Representative <input checked="" type="checkbox"/> Approval Recommended <input type="checkbox"/> Approved	Date 7-31-17
Contract Administrator <input type="checkbox"/> Approval Recommended <input checked="" type="checkbox"/> Approved <i>[Signature]</i>			Date 7-31-17
Office Director <input type="checkbox"/> Approved			Date

FINAL APPROVAL SIGNATURE REQUIRED BY WORK AUTHORIZATION GROUP:

GROUP	AUTHORIZATION APPROVAL LEVEL
1. Less than \$10,000	Designated Division or District Technical Representative
2. Equal to \$10,000-\$50,000	Contract Administrator - Division or District Engineer
3. Equal to \$50,000-\$100,000	Office Director
4. Greater than \$100,000	Office Director After Review with Deputy Director

NDDOT Distribution: Submit original copy to Environmental and Transportation Services, Consultant Administrative Services, one copy to Consultant, and project file.

PUBLIC WORKS PROJECTS EVALUATION COMMITTEE

Improvement District No. BN-17-G1 Type: Time Extension (CO#1)
 Location: Bison Meadows Addition Date of Hearing: 10/16/2017

Routing Date
 City Commission 10/23/2017
 PWPEC File X
 Project File Jason Satterlund

The Committee reviewed the accompanying correspondence from Project Manager, Jason Satterlund, regarding a time extension requested by Ryan Contracting.

The Contractor has requested a 7-day time extension due to weather related delays and 1-day for a survey error on staking curb and gutter.

Staff is recommending approval of the time extension as shown below:

Original Completion Dates	Revised Previously	Revised This Memo
Substantial – October 13, 2017 Final – November 10, 2017	- -	Substantial – October 21, 2017 Final – November 10, 2017

On a motion by Mark Bittner, seconded by Ben Dow, the Committee voted to recommend approval of the time extension as shown above.

RECOMMENDED MOTION

Concur with the recommendations of PWPEC and approve the time extension.

PROJECT FINANCING INFORMATION:

Recommended source of funding for project: Special Assessments

	Yes	No
Developer meets City policy for payment of delinquent specials	<input checked="" type="checkbox"/>	<input type="checkbox"/>
Agreement for payment of specials required of developer	<input checked="" type="checkbox"/>	<input type="checkbox"/>
Letter of Credit required (per policy approved 5-28-13)	<input checked="" type="checkbox"/>	<input type="checkbox"/>

COMMITTEE

- Tim Mahoney, Mayor
- Jim Gilmour, Director of Planning
- Steve Dirksen, Fire Chief
- Mark Bittner, Director of Engineering
- Bruce Grubb, City Administrator
- Ben Dow, Director of Operations
- Steve Sprague, City Auditor
- City Engineer
- Kent Costin, Finance Director

Present	Yes	No	Unanimous
<input type="checkbox"/>	<input type="checkbox"/>	<input type="checkbox"/>	<input checked="" type="checkbox"/>
<input checked="" type="checkbox"/>	<input checked="" type="checkbox"/>	<input type="checkbox"/>	
<input checked="" type="checkbox"/>	<input checked="" type="checkbox"/>	<input type="checkbox"/>	<input type="checkbox"/>
<input checked="" type="checkbox"/>	<input checked="" type="checkbox"/>	<input type="checkbox"/>	<input type="checkbox"/>
<input checked="" type="checkbox"/>	<input checked="" type="checkbox"/>	<input type="checkbox"/>	<input type="checkbox"/>
<input checked="" type="checkbox"/>	<input checked="" type="checkbox"/>	<input type="checkbox"/>	<input type="checkbox"/>
<input checked="" type="checkbox"/>	<input checked="" type="checkbox"/>	<input type="checkbox"/>	<input type="checkbox"/>
<input checked="" type="checkbox"/>	<input checked="" type="checkbox"/>	<input type="checkbox"/>	<input type="checkbox"/>
<input type="checkbox"/>	<input type="checkbox"/>	<input type="checkbox"/>	<input type="checkbox"/>

ATTEST:

 Brenda E. Derrig, P.E.
 Division Engineer

C: Kristi Olson



Memorandum

To: PWPEC

From: Jason Satterlund, Project Engineer *JTS*

Date: October 10, 2017

Re: Improvement District No. BN-17-G1 – Time Extension #1

Background:

Improvement District No. BN-17-G1 is for Sanitary Sewer, Water Main, Storm Sewer, Paving, Street Lights, Site Grading & Incidentals on 16th Street, 66th & 67th Avenues South in Bison Meadows Addition.

Ryan Contracting is the Contractor for this project. They are requesting a time extension of 7 days due to weather related delays and 1 day for a survey error on staking curb and gutter. After evaluating the delays caused by rain, I am recommending an extension of 5 working days (7 calendar days) for the weather delays and 1 working day for the survey error, to the completion date. Along with that extension, I'm in agreement with Ryan Contracting's request to move the completion of the pond excavation to the final completion date, which shall remain unchanged at November 10, 2017.

Recommended Motion:

Approve Time Extension #1 to the new substantial completion date as shown below:

Original Completion Dates	Revised Previously	Revised This Memo
Substantial – October 13, 2017 Final – November 10, 2017	- -	Substantial – October 21, 2017 Final – November 10, 2017

JTSjmg

Attachments

C: Thomas Knakmuhs



October 9, 2017

City of Fargo
Attn: Jason Satterlund
209 3rd St. N.
Fargo, MN 58102

RE: **FARGO BN-17-G1 – BISON MEADOWS**
Fargo, ND (RCC #1078)

Dear Jason:

Please take this letter as our formal request for an extension of time to complete the above referenced project. For the right of way portion we are asking to be complete on October 20, 2017 and for the pond area to be completed by November 10, 2017 for the following reasons:

We have incurred numerous rain delays on this project. We experienced rain to impede our work on September 15, September 19, September 23-September 26, and October 1-2. We also had 1-3 days following those specified dates that caused our production to be slower because of the wet soil conditions on the project.

Our proposed schedule to complete the project is as follows:

- Curb and gutter – Monday Oct 9 – Tuesday October 10
- Sidewalk – October 10-October 12
- Bituminous - Friday October 13
- Bituminous final lift scheduled for October 18.
- The street lights, traffic sign, striping are all scheduled for some time during the week of October 16.
- Our seeding contractor has agreed to come and seed in two parts – come and do the streets and lots and then come back and seed the pond when ready.
- Complete grading of pond area by November 10, 2017

Our plan is to concentrate on the right of way work so that work will not affect building permits than after that work is completed move onto the pond work. Also, as you know the pond work was redesigned from the original plan.

Please know that, we have been in constant communication with Jon Youness in regards to the progression of the work and he seems completely satisfied with our timing and progress on the project.

Jason, we have really tried hard to complete this project on time and we always knew this would be extremely tight completion date even without the weather we have experienced. We would greatly appreciate your support to get the completion date extended.

Thank you for your time on this matter. If you have any questions or comments, please do not hesitate to contact us.

Sincerely,

A handwritten signature in cursive script that reads "Beth R. Tatge".

Beth R. Tatge
CFO/Secretary



October 11, 2017

City of Fargo
Attn: Jason Satterlund
209 3rd St. N.
Fargo, MN 58102

RE: **FARGO BN-17-G1 – BISON MEADOWS**
Fargo, ND (RCC #1078)

Dear Jason:

Ryan Contracting requests one additional day for the delay caused by the survey error in staking curb and gutter on October 10, 2017.

Thank you for your time on this matter. If you have any questions or comments, please do not hesitate to contact us.

Sincerely,

A handwritten signature in cursive script that reads "Beth R. Tatge".

Beth R. Tatge
CFO/Secretary



CITY OF FARGO
ENGINEERING DEPARTMENT
CHANGE ORDER REPORT

Improvement District No	BN-17-G1	Change Order No	1
Project Name	Sanitary Sewer, Water Main, Storm Sewer, Paving, Street Lights, Site Grading & Incidentals		
Date Entered	10/17/2017	For	Ryan Contracting

This change is made under the terms of or is supplemental to your present contract, if and when approved, you are ordered to perform the work in accordance with the additions, changes, or alterations hereinafter described.

EXPLANATION OF CHANGE: Time extension request

Section	Line No	Item Description	Unit	Orig Cont Qty	Prev C/O Qty	Prev Cont Qty	Curr C/O Qty	Tot Cont Qty	Unit Price (\$)	C/O Ext Price (\$)
Summary										
Source Of Funding										
Net Amount Change Order # 1 (\$)										
Previous Change Orders (\$)										
Original Contract Amount (\$)										
Total Contract Amount (\$)										

I hereby accept this order both as to work to be performed and prices on which payment shall be based.

CONTRACT TIME		
Current Completion Date	Additional Days	New Completion Date
11/15/2017	-5.00	11/10/2017
Description		
8 days were added to the substantial completion date. 7 days were weather related delays and 1 day for surveying errors. This changed the substantial completion date from October 13, 2017 to October 21, 2017. Completion of the retention pond was moved from the substantial completion to the final completion date. The final completion date of the contract remained the same at November 10, 2017.		

The adjustment of -5 days shown on this change order are to amend an incorrectly entered final completion date of November 15, 2017 to the original contract final completion date of November 10, 2017.

APPROVED _____ APPROVED DATE _____

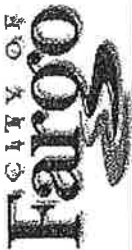

CITY OF FARGO
ENGINEERING DEPARTMENT
CHANGE ORDER REPORT

For Contractor	<i>Whitney</i>	Department Head	<i>[Signature]</i>
Title	<i>CEO</i>	Mayor	10/18/17
		Attest	

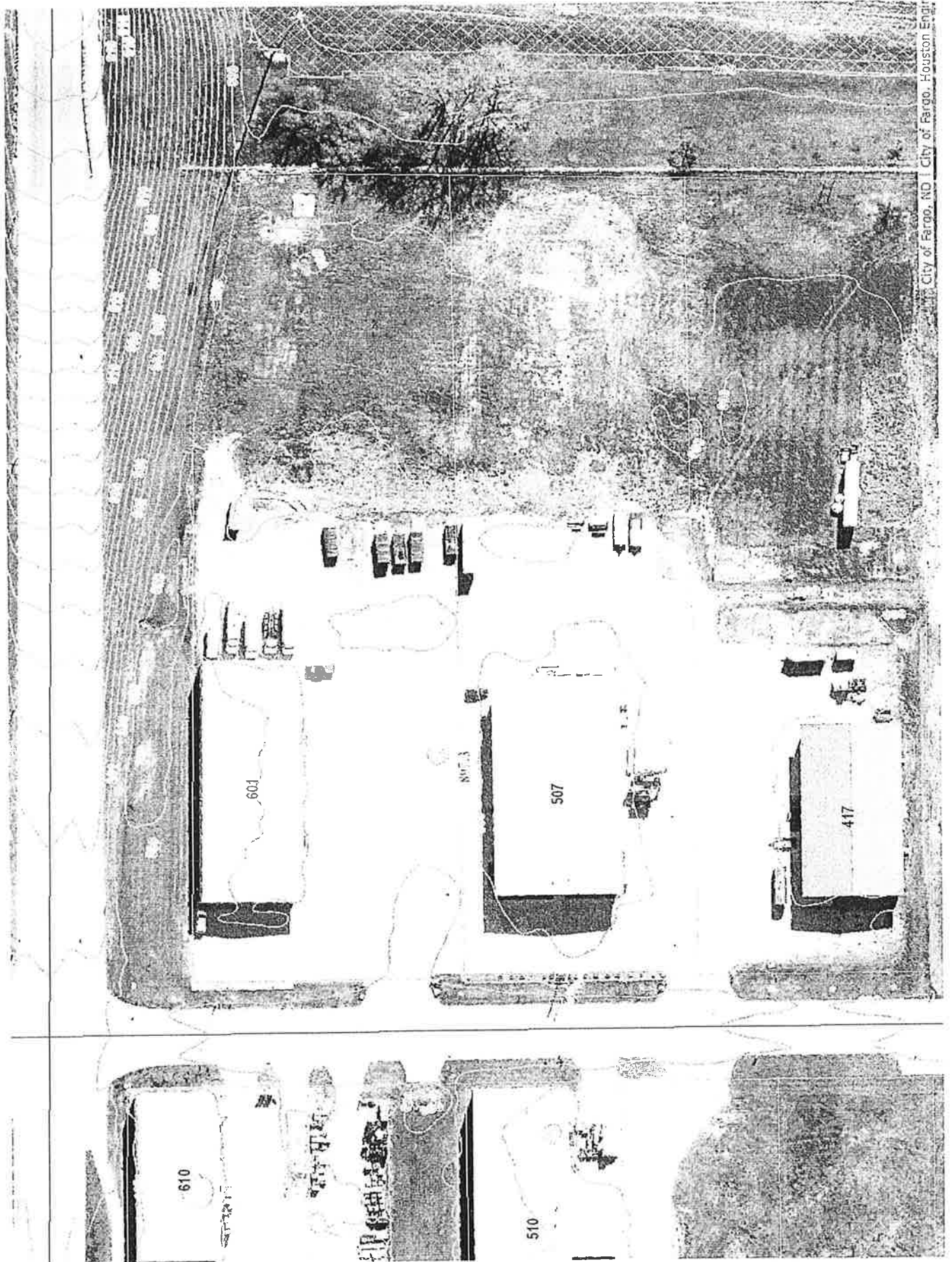

PUBLIC WORKS PROJECTS EVALUATION COMMITTEE

Improvement District No. BR-17-J1 Type: Time Extension (CO#2)
 Location: 22nd Ave S, 23rd Ave S, 6th St S Date of Hearing: 10/16/2017

<u>Routing</u>	<u>Date</u>
City Commission	10/23/2017
PWPEC File	X
Project File	Rob Hasey

The Committee reviewed the accompanying correspondence from Project Manager, Rob Hasey, regarding a time extension requested by Tom's Backhoe Service.

The Contractor has requested a 6-day time extension as allowed per the contract.

Staff is recommending approval of the time extension as shown below:

Original Completion Dates	Revised Previously	Recommended by Staff
Intermediate – August 28, 2017	September 5, 2017	-
Substantial – September 28, 2017	October 6, 2017	Substantial – October 12, 2017
Final – October 28, 2017	November 6, 2017	Final – November 12, 2017

On a motion by Mark Bittner, seconded by Ben Dow, the Committee voted to recommend approval of the time extension as shown above.

RECOMMENDED MOTION

Concur with the recommendations of PWPEC and approve the time extension.

PROJECT FINANCING INFORMATION:

Recommended source of funding for project: Sales Tax Funds, Utility Funds & Special Assessments

	Yes	No
Developer meets City policy for payment of delinquent specials	<u>N/A</u>	<u> </u>
Agreement for payment of specials required of developer	<u>N/A</u>	<u> </u>
Letter of Credit required (per policy approved 5-28-13)	<u>N/A</u>	<u> </u>

COMMITTEE

	Present	Yes	No	Unanimous
				<u>13</u>
Tim Mahoney, Mayor	<input type="checkbox"/>	<input type="checkbox"/>	<input type="checkbox"/>	
Jim Gilmour, Director of Planning	<input checked="" type="checkbox"/>	<input checked="" type="checkbox"/>	<input type="checkbox"/>	
Steve Dirksen, Fire Chief	<input checked="" type="checkbox"/>	<input checked="" type="checkbox"/>	<input type="checkbox"/>	Ryan Erickson
Mark Bittner, Director of Engineering	<input checked="" type="checkbox"/>	<input checked="" type="checkbox"/>	<input type="checkbox"/>	
Bruce Grubb, City Administrator	<input checked="" type="checkbox"/>	<input checked="" type="checkbox"/>	<input type="checkbox"/>	
Ben Dow, Director of Operations	<input checked="" type="checkbox"/>	<input checked="" type="checkbox"/>	<input type="checkbox"/>	
Steve Sprague, City Auditor	<input checked="" type="checkbox"/>	<input checked="" type="checkbox"/>	<input type="checkbox"/>	
City Engineer	<input checked="" type="checkbox"/>	<input checked="" type="checkbox"/>	<input type="checkbox"/>	Brenda Derrig
Kent Costin, Finance Director	<input type="checkbox"/>	<input type="checkbox"/>	<input type="checkbox"/>	

ATTEST:

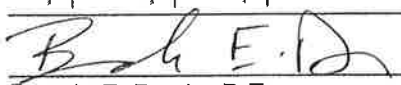
 Brenda E. Derrig, P.E.
 Division Engineer

C: Kristi Olson



Memorandum

To: PWPEC

From: Rob Hasey, Civil Engineer I, Storm Sewer Utility *RH*

Cc: Brenda Derrig, Division Engineer

Date: 10/10/2017

Re: Improvement District No. BR-17-J1 – Time Extension (CO #2)

Background:

Tom's Backhoe Service has completed 7 sewer service replacements from the sewer main in the street to 5' behind the curb on phase 2. The Contractor is allowed a time extension of one half day per sewer service as per the contract.

Attached to this memorandum is a change order for adding additional days to the contract. Half day extensions aren't able to be processed in Masterworks so 3.5 days was rounded up to 4 days. The attached change order is for a total of 6 days to be added to the contract due to October 7th and 8th falling on Saturday and Sunday. Substantial completion shall be changed to October 12th, 2017 and final completion shall be changed to November 12th.

Recommended Motion:

Approve a time extension for the substantial and final completion dates as shown:

Original Completion Dates	Revised Previously	Recommended by Staff
Intermediate – August 28, 2017	September 5, 2017	-
Substantial – September 28, 2017	October 6, 2017	Substantial – October 12, 2017
Final – October 28, 2017	November 6, 2017	Final – November 12, 2017

RJH/klo
Attachment



CITY OF FARGO
ENGINEERING DEPARTMENT
CHANGE ORDER REPORT

Improvement District No BR-17-J1 Change Order No 2
 Project Name Water Main Replacement, Street Reconstruction & Incidentals
 Date Entered 10/10/2017 For Tomis Backhoe Service Inc

This change is made under the terms of or is supplemental to your present contract, if and when approved, you are ordered to perform the work in accordance with the additions, changes, or alterations hereinafter described.

EXPLANATION OF CHANGE: Add days to contract for extra work performed (sanitary sewer service replacement at 7 houses)

Section	Line No	Item Description	Unit	Orig Cont Qty	Prev C/O Qty	Prev Cont Qty	Curr C/O Qty	Tot Cont Qty	Unit Price (\$)	C/O Ext Price (\$)
Summary										
Source Of Funding										
Net Amount Change Order # 2 (\$)										
Previous Change Orders (\$) 0.00										
Original Contract Amount (\$) 854,133.10										
Total Contract Amount (\$) 854,133.10										

I hereby accept this order both as to work to be performed and prices on which payment shall be based.

CONTRACT TIME

Description	Current Completion Date	Additional Days	New Completion Date
APPROVED	10/06/2017	6.00	10/12/2017

APPROVED

APPROVED DATE

For Contractor

Department Head



10/17/17

Title

Vice President



CITY OF FARGO
ENGINEERING DEPARTMENT
CHANGE ORDER REPORT

Attest

32

REPORT OF ACTION

PUBLIC WORKS PROJECTS EVALUATION COMMITTEE

Improvement District No. PR-17-A1

Type: Utility Reimbursement Agreement Consolidated Communications

Location: 32nd Ave S - 32nd St to 42nd St S

Date of Hearing: 10/16/2017

<u>Routing</u>	<u>Date</u>
City Commission	<u>10/23/2017</u>
PWPEC File	<u>X</u>
Project File	<u>Jeremy Gorden</u>

The Committee reviewed a memorandum from Traffic Division Engineer, Jeremy Gorden, regarding a Utility Reimbursement Agreement with Consolidated Communications. The Agreement is necessary to facilitate the relocation of buried communication lines on the south side of 32nd Avenue S to accommodate the reconstruction and widening of 32nd Avenue S. The estimated cost of the work is \$26,310.

Staff is recommending approval of the Reimbursement Agreement.

On a motion by Mark Bittner, seconded by Brenda Derrig, the Committee voted to recommend approval of the Reimbursement Agreement as presented.

RECOMMENDED MOTION

Concur with the recommendations of PWPEC and approve the Reimbursement Agreement with Consolidated Communications for the estimated amount of \$26,310.

PROJECT FINANCING INFORMATION:

Recommended source of funding for project:	<u>Special Assessments & Sales Tax Funds</u>	Yes	No
Developer meets City policy for payment of delinquent specials		<u>N/A</u>	<u>N/A</u>
Agreement for payment of specials required of developer		<u>N/A</u>	<u>N/A</u>
Letter of Credit required (per policy approved 5-28-13)		<u>N/A</u>	<u>N/A</u>

COMMITTEE

	<u>Present</u>	<u>Yes</u>	<u>No</u>	<u>Unanimous</u>
				<input checked="" type="checkbox"/>
Tim Mahoney, Mayor	<input checked="" type="checkbox"/>	<input checked="" type="checkbox"/>	<input type="checkbox"/>	
Jim Gilmour, Director of Planning	<input checked="" type="checkbox"/>	<input checked="" type="checkbox"/>	<input type="checkbox"/>	
Steve Dirksen, Fire Chief	<input checked="" type="checkbox"/>	<input checked="" type="checkbox"/>	<input type="checkbox"/>	Ryan Erickson
Mark Bittner, Director of Engineering	<input checked="" type="checkbox"/>	<input checked="" type="checkbox"/>	<input type="checkbox"/>	
Bruce Grubb, City Administrator	<input checked="" type="checkbox"/>	<input checked="" type="checkbox"/>	<input type="checkbox"/>	
Ben Dow, Director of Operations	<input checked="" type="checkbox"/>	<input checked="" type="checkbox"/>	<input type="checkbox"/>	
Steve Sprague, City Auditor	<input checked="" type="checkbox"/>	<input checked="" type="checkbox"/>	<input type="checkbox"/>	
City Engineer	<input checked="" type="checkbox"/>	<input checked="" type="checkbox"/>	<input type="checkbox"/>	Brenda Derrig
Kent Costin, Finance Director	<input checked="" type="checkbox"/>	<input checked="" type="checkbox"/>	<input type="checkbox"/>	

ATTEST:

C: Kristi Olson

 Brenda E. Derrig, P.E.
 Division Engineer

Memo

October 11, 2017

To: Members of PWPEC

From: Jeremy Gorden, P.E., PTOE *Jmg*
Division Engineer - Transportation

Subject: Reimbursement Agreement with Consolidated Communications for Utility Relocations as part of the 32nd Avenue South Street Reconstruction Project
32nd Street to 42nd Street
City of Fargo Improvement District No. PR-17-A1

I've attached a Reimbursement Agreement from Consolidated Communications that is for relocating their underground along 32nd Avenue South as part of this street reconstruction project. This work is now complete. Please review the attached agreement and let me know if you have any questions. The cost of doing this work is \$26,310. This work and associated cost was anticipated during design and was included in the project cost estimate.

Recommended Action

I would recommend approval of the Reimbursement Agreement from Consolidated Communications to relocate their underground utilities as part of this street reconstruction project.

JMG/jmg
Attachment



August 2nd, 2017

City of Fargo
200 3rd St N
Fargo, North Dakota 58102

Dear City of Fargo:

Consolidated Communications Formerly Enventis and/or IdeaOne Telecom was approached by Apex Engineering about relocating some of our existing facilities along 32nd Ave S as part of the 32nd Ave S road construction project known as SU-8-984(152)155 in Fargo, ND. Work has been completed to relocate all of our existing utilities that were identified to be in conflict with the road project with the total reimbursable cost being \$26,310. Consolidated Communications is formally requesting to be reimbursed for this relocation work at this time. Please see the attached breakdown with the locations of where the relocation work took place as well as which locations were reimbursable and which ones weren't. Lines highlighted in green indicate there was no conflict and no relocation work took place, lines highlighted in orange indicate locations where relocation work took place but is not reimbursable, and lines highlighted in yellow indicate locations where relocation work took place and is reimbursable. Please see the attached relocation agreement document that will need to be signed by both parties. The signed relocation agreement can be mailed to me at our Fargo office and I will sign and send back a copy.

Consolidated Communication
Attn: Ross Branstner
3312 42nd St S. Suite 100
Fargo, ND 58104

Feel free to call me at 701-356-6004 or email me at Ross.Branstner@consolidated.com if you have any further questions regarding this project.

Sincerely,

A handwritten signature in blue ink, appearing to read "Ross Branstner".

Ross Branstner
Outside Plant Manager

Consolidated Communicaitons 32nd Ave S. Fargo Reimbursable Relocation Costs

Item No (As per Utility Conflict Summary Sheet)	<u>Description</u>	<u>Cost</u>
CC -18	Contract Labor	\$5,723.50
	Materials	\$882.00
	Internal Labor (Regular Hours)	\$936.00
	Internal Labor (After Hours Time)	\$936.00
	<u>Total</u>	\$8,477.50
CC -22	Contract Labor	\$750.00
	Materials	
	Internal Labor (Regular Hours)	\$468.00
	Internal Labor (After Hours Time)	
	<u>Total</u>	\$1,218.00
CC-24	Contract Labor	\$750.00
	Materials	
	Internal Labor (Regular Hours)	\$546.00
	Internal Labor (After Hours Time)	
	<u>Total</u>	\$1,296.00
CC-26, C-28, C-32	Contract Labor	\$9,376.25
	Materials	\$2,363.46
	Internal Labor (Regular Hours)	\$2,652.00
	Internal Labor (After Hours Time)	\$936.00
	<u>Total</u>	\$15,327.71
<u>Total Relocaton Project cost</u>		<u>\$26,319.21</u>

**REIMBURSEMENT AGREEMENT FOR
UTILITY INFRASTRUCTURE**

This REIMBURSEMENT AGREEMENT FOR UTILITY INFRASTRUCTURE (the "Agreement") is entered into between CITY OF FARGO, (the "City"), and CONSOLIDATED COMMUNICATIONS ENTERPRISE SERVICES, INC., a Delaware corporation ("Consolidated"), to be effective as of the last date executed below. The parties agree as follows:

1. Consolidated operates facility based telecommunications services and provides services to customers in the greater Fargo area. City now desires for Consolidated to relocate facilities to accommodate its plan for a project known as 32nd Ave S. Road Project known as SU-8-984(152)155. Pursuant to the request of City and in accordance with the terms of this Agreement, Consolidated agrees to perform certain work on the Site as described on the work order attached as Exhibit A (the "Project").
2. City represents and warrants to Consolidated that City has all necessary right, title, license, and authority from Owner and otherwise authorizing Consolidated to perform the Project on the Owner's property and to grant Consolidated access to the Site.
3. The City agrees to reimburse Consolidated's costs of the Project (the "Costs") as set forth on Exhibit A (the "Construction Crew").
4. The Costs for the Project will be invoiced by Consolidated upon completion and will be due within thirty (30) days following receipt by the City of the invoice. In the event the City fails to pay any amounts due under the terms of this Agreement, City agrees to pay interest on the amounts past due at the rate of 1½% per month.
5. Each party maintains, at a minimum, the insurance coverage set forth on attached Exhibit B.
6. Upon execution of this Agreement by the parties, Consolidated will commence and endeavor to complete the Project as soon as possible, subject to force majeure events, including without limitation, unavailability of materials, labor unrest, acts of God, acts of public enemies, or any law, order, regulation, ordinance or requirement of any government or legal body or any representative of any such government or legal body.
7. The following miscellaneous provisions shall additionally apply to this Agreement:
 - a. This Agreement comprises the complete and exclusive statement of the agreement of the parties concerning the subject matter hereof, and supersedes all previous statements, representations, and agreements between the parties. No subsequent agreement concerning modification to this Agreement shall be binding upon the parties unless it is made in writing by an authorized representative of each party.
 - b. Each party agrees to take such further or additional action and execute and deliver to the other party such further or additional instruments, agreements, or other documents as shall be reasonably requested by the other party in order to complete, assure and/or

evidence, or more fully complete, assure and/or evidence, the transactions contemplated or described herein.

- c. The relationship between City and Consolidated shall not be that of partners, agents, or joint venturers for one another, and nothing contained in this Agreement shall be deemed to constitute a partnership or agency agreement between them for any purposes.
- d. NEITHER PARTY SHALL BE LIABLE TO THE OTHER PARTY FOR ANY INDIRECT, INCIDENTAL, SPECIAL, PUNITIVE OR CONSEQUENTIAL DAMAGES ARISING UNDER THIS AGREEMENT OR FROM ANY BREACH OR PARTIAL BREACH OF THE PROVISIONS OF THIS AGREEMENT OR ARISING OUT OF ANY ACT OR OMISSION OF THE PARTY OR ITS OR ITS AFFILIATES' DIRECTORS, OFFICERS, EMPLOYEES, SERVANTS, CITYS AND/OR AGENTS.
- e. This Agreement is for the sole benefit of the parties to this Agreement and their respective successors and assigns. Nothing in this Agreement shall give or be construed to give any person or entity, other than the parties to this Agreement and their respective successors and assigns, any legal or equitable rights under this Agreement.
- f. The parties agree that this Agreement shall be construed under the laws of the State of North Dakota without regard to choice of law principles and venue shall be in Cass County, North Dakota.
- g. This Agreement may be executed in counterparts, each of which shall be deemed an original, but all of which taken together shall constitute one and the same instrument. Facsimile and pdf signatures to this Agreement shall be acceptable and binding.
- h. Notices delivered under this Agreement shall be delivered to a party at the address set forth on Exhibit A and must be either (i) delivered by hand delivery to the, with written acceptance of said delivery by the other party, and shall be deemed given on the date so accepted, (ii) mailed by certified or registered mail, postage prepaid, return receipt requested and shall be deemed given on the third (3rd) business day after the date of posting in a United States Post Office, or (iii) given by a nationally recognized overnight courier and shall be deemed given one day after delivery to the overnight courier.

[signature page(s) follow]

By executing below, each of the undersigned represents and warrants that the undersigned has authority to execute this Agreement and that the Agreement has been fully authorized by the applicable party.

EXECUTED to be effective as of the last date set forth below.

CITY OF FARGO

By: _____
Print Name: Timothy J. Mahoney
Title: Mayor
Date: _____

**CONSOLIDATED
COMMUNICATIONS ENTERPRISE
SERVICES, INC.**

By: _____
Print Name: _____
Title: _____
Date: _____

Utility Conflict Summary Sheet													SU-8-984(152)155 - 32ND AVES	
Item No	Utility	Type of Facility	P&P Sheet	X Sec Sheet	Begin Sta	End Sta	Offset	Units		Location	Comments	1 City 2 Utility		Reimbursable / Not Reimbursable
								Feet	EA					
CC-17	Consolidated Communication	Fiber Line Underground	4	22	110+16		Lt	25		Inside Right of Way	Proposed Storm Sewer Conflicts	2		Not Reimbursable
CC-18	Consolidated Communication	Fiber Line Underground	4	22	110+16		Lt	26		Outside Right of Way	Proposed Storm Sewer Conflicts	1		Reimbursable
CC-19	Consolidated Communication	Fiber Line Underground	4	22	110+23		Lt	55		Inside Right of Way	Proposed Storm Sewer Conflicts	2		Not Reimbursable
CC-20	Consolidated Communication	Fiber Line Underground	4	25-26	111+58	111+88	Lt	30		Outside Right of Way	Proposed Storm Sewer Conflicts	1		Reimbursable
CC-21	Consolidated Communication	Fiber Line Underground	4	28-29	113+17	113+93	Lt	77		Inside Right of Way	Proposed Storm Sewer Conflicts	2		Not Reimbursable
CC-22	Consolidated Communication	Fiber Line Vault	4	29	114+05		Lt		1	Inside Right of Way	Proposed Sidewalk Conflict	2		Not Reimbursable
CC-23	Consolidated Communication	Fiber Line Underground	4	29	114+07		Lt	55		Inside Right of Way	Proposed Storm Sewer Conflicts	2		Not Reimbursable
CC-24	Consolidated Communication	Fiber Line Underground	4	29	114+15		Rt	10		Outside Right of Way	Conflict Depending on Cover	1		Reimbursable
CC-25	Consolidated Communication	Telephone Pedestal	8	58	145+26		Lt		1	Inside Right of Way	Conflict Depending on Cover	2		Not Reimbursable
CC-26	Consolidated Communication	Fiber Line Underground	8	58	145+34		Lt & Rt	93		Inside Right of Way	Proposed Storm Sewer Conflicts	2		Not Reimbursable
CC-27	Consolidated Communication	Fiber Line Underground	8	60-61	146+20	146+50	Lt	30		Inside Right of Way	Proposed Storm Sewer Conflicts	2		Not Reimbursable
CC-28	Consolidated Communication	Fiber Line Underground	8	61-61	146+26	146+56	Lt	30		Outside Right of Way	Proposed Storm Sewer Conflicts	1		Reimbursable
CC-29	Consolidated Communication	Fiber Line Underground	8-9	65	148+80	149+10	Rt	30		Inside Right of Way	Proposed Storm Sewer Conflicts	2		Not Reimbursable
CC-30	Consolidated Communication	Fiber Line Vault	9	66	150+30		Lt		1	Outside Right of Way	Conflict Depending on Cover	1		Reimbursable
CC-31	Consolidated Communication	Fiber Line	9	67-68	150+95	151+60	Rt	65		Inside Right of Way	Proposed Water Main Conflicts	2		Not Reimbursable
CC-32	Consolidated Communication	Fiber Line Pedestal	9	68	151+55		Rt		1	Outside Right of Way	Conflict Depending on Cover	1		Reimbursable
CC-33	Consolidated Communication	Fiber Line Underground	9	68	151+55		Lt & Rt	92		Inside Right of Way	Proposed Storm Sewer Conflicts	2		Not Reimbursable
CC-34	Consolidated Communication	Fiber Line Pedestal	9	68	151+56		Lt		1	Outside Right of Way	Conflict Depending on Cover	1		Reimbursable
CC-35	Consolidated Communication	Fiber Line Pedestal	9	68	151+57		Rt		1	Inside Right of Way	Conflict Depending on Cover	2		Not Reimbursable
CC-36	Consolidated Communication	Fiber Line Underground	9	68-69	151+61	152+31	Rt	71		Inside Right of Way	Conflict Depending on Cover	2		Not Reimbursable
CC-37	Consolidated Communication	Fiber Line Underground	9	68-69	151+78	152+25	Lt	47		Inside Right of Way	Conflict Depending on Cover	2		Not Reimbursable
CC-38	Consolidated Communication	Fiber Pedestal	9	70	152+35		Lt		1	Outside Right of Way	Conflict Depending on Cover	1		Reimbursable
CC-39	Consolidated Communication	Fiber Line Underground	5	39	3807+34		Lt & Rt	63		Inside Right of Way	Conflict Depending on Cover	2		Not Reimbursable
DC - 01	Dak Carr	Fiber Line Underground	8	60	146+12		Lt & Rt	118		Inside Right of Way	Proposed Storm Sewer Conflicts	2		Not Reimbursable
MC - 01	Misco	Fiber Line Underground	2	9	99+48	99+78	Rt	32		Inside Right of Way	Conflict Depending on Cover	2		Not Reimbursable
MC - 02	Misco	Fiber Line Underground	2	9	99+90	100+18	Rt	28		Inside Right of Way	Conflict Depending on Cover	2		Not Reimbursable
MC - 03	Misco	Fiber Line Underground	2	10	100+72	101+03	Rt	55		Inside Right of Way	Conflict Depending on Cover	2		Not Reimbursable
MC - 04	Misco	Fiber Line Underground	2	10	101+08	101+23	Lt	38		Inside Right of Way	Proposed Storm Sewer Conflicts	2		Not Reimbursable
MC - 05	Misco	Fiber Pedestal	2	12	102+84		Lt		1	Inside Right of Way	Proposed Sidewalk Conflict	2		Not Reimbursable
MC - 06	Misco	Fiber Line Underground	3	15	104+95	105+46	Lt	50		Inside Right of Way	Conflict Depending on Cover	2		Not Reimbursable
MC - 07	Misco	Fiber Line Vault	3	15	105+54		Lt		1	Inside Right of Way	Proposed Sidewalk Conflict	2		Not Reimbursable
MC - 08	Misco	Fiber Line Underground	4	22	110+05	110+35	Lt	30		Outside Right of Way	Proposed Storm Sewer Conflicts	1		Reimbursable
MC - 09	Misco	Fiber Line Underground	4	25-26	111+58	111+88	Lt	30		Outside Right of Way	Proposed Storm Sewer Conflicts	1		Reimbursable

Relocation Completed
not Reimbursable

Relocation Completed
is Reimbursable

No Conflict

Utility Conflict Summary Sheet													SU-8-984(152)155 - 32ND AVE S	
Item No	Utility	Type of Facility	P&P Sheet	X Sec Sheet	Begin Sta	End Sta	Offset	Units		Location	Comments	1 City 2 Utility		Reimbursable / Not Reimbursable
								Feet	EA					
CL - 26	Century Link	Fiber Line Underground	4	28-30	113+12	114-52	Rt	130		Inside Right of Way	Conflict Depending on Cover	2	2	Not Reimbursable
CL - 27	Century Link	Fiber Line Underground	4	28	113+13		Lt	22		Inside Right of Way	Conflict Depending on Cover	2	2	Not Reimbursable
CL - 28	Century Link	Telephone Line Underground	4	28-29	113+17	114+10	Rt	100		Inside Right of Way	Conflict Depending on Cover	2	2	Not Reimbursable
CL - 29	Century Link	Telephone Line Underground	4	29	114+10		Rt	28		Outside Right of Way	Conflict Depending on Cover	1	1	Reimbursable
CL - 30	Century Link	Fiber Line Vault	7	48	139+03		Rt		1	Inside Right of Way	Proposed Sidewalk Conflict	2	2	Not Reimbursable
CL - 31	Century Link	Telephone Vault	8	56	144+09		Rt		1	Inside Right of Way	Proposed Roadway Conflict	2	2	Not Reimbursable
CL - 32	Century Link	Fiber Line Underground	8	56	144+17		Rt	61		Inside Right of Way	Conflict Depending on Cover	2	2	Not Reimbursable
CL - 33	Century Link	Fiber Line Underground	8	57	144+56		Lt & Rt	95		Inside Right of Way	Proposed Storm Sewer Conflicts	2	2	Not Reimbursable
CL - 34	Century Link	Telephone Vault	8	58	145+41		Rt		1	Inside Right of Way	Conflict Depending on Cover	2	2	Not Reimbursable
CL - 35	Century Link	Telephone Line Underground	8	58	145+44		Lt & Rt	122		Inside Right of Way	Conflict Depending on Cover	2	2	Not Reimbursable
CL - 36	Century Link	Telephone Line Underground	8	59-60	145+47	146+08	Rt	61		Inside Right of Way	Conflict Depending on Cover	2	2	Not Reimbursable
CL - 37	Century Link	Telephone Pedestal	8	60	146+18		Lt		1	Inside Right of Way	Proposed Sidewalk Conflicts	2	2	Not Reimbursable
CL - 38	Century Link	Telephone Line Underground	8	60-61	146+26	146+56	Lt	30		Outside Right of Way	Proposed Storm Sewer Conflicts	1	1	Reimbursable
CL - 39	Century Link	Telephone Line Underground	8-9	65	148+80	149+10	Rt	30		Outside Right of Way	Proposed Water Main Conflicts	1	1	Reimbursable
CL - 40	Century Link	Telephone Pedestal	8	65	148+92		Rt		1	Outside Right of Way	Conflict Depending on Cover	1	1	Reimbursable
CL - 41	Century Link	Telephone Line Underground	8-9	65	148+93	149+10	Rt	24		Outside Right of Way	Proposed Water Main Conflicts	1	1	Reimbursable
CL - 42	Century Link	Telephone Line Underground	9	67-68	150+95	151+25	Rt	30		Outside Right of Way	Proposed Water Main Conflicts	1	1	Reimbursable
CL - 43	Century Link	Telephone Line Underground	9	68-69	151+64	152+25	Rt	61		Inside Right of Way	Conflict Depending on Cover	2	2	Not Reimbursable
CL - 44	Century Link	Telephone Line Underground	9	70	152+40		Lt & Rt	80		Inside Right of Way	Conflict Depending on Cover	2	2	Not Reimbursable
CL - 45	Century Link	Fiber Line Underground	9	70	152+46		Lt & Rt	76		Inside Right of Way	Conflict Depending on Cover	2	2	Not Reimbursable
CL - 46	Century Link	Fiber Line Underground	5	41-42	3908+10	3908+40	Lt	30		Outside Right of Way	Proposed Storm Sewer Conflict	1	1	Reimbursable
CL - 47	Century Link	Fiber Line Underground	5	43-44	3909+10	3909+40	Lt	30		Outside Right of Way	Proposed Storm Sewer Conflicts	1	1	Reimbursable
CL - 48	Century Link	Fiber Line Underground	3	15	104+95	105+46	Lt	50		Inside Right of Way	Conflict Depending on Cover	2	2	Not Reimbursable
CC-01	Consolidated Communication	Fiber Line Underground	2	8	99+00		Rt	28		Inside Right of Way	Conflict Depending on Cover	2	2	Not Reimbursable
CC-02	Consolidated Communication	Telephone Line Underground	2	8	99+00		Lt	15		Inside Right of Way	Conflict Depending on Cover	2	2	Not Reimbursable
CC-03	Consolidated Communication	Fiber Line Underground	2	8	99+06		Lt	30		Inside Right of Way	Proposed Storm Sewer Conflict	2	2	Not Reimbursable
CC-04	Consolidated Communication	Fiber Line Underground	2	9	99+48	99+78	Rt	32		Inside Right of Way	Conflict Depending on Cover	2	2	Not Reimbursable
CC-05	Consolidated Communication	Fiber Line Underground	2	9	99+48	99+78	Rt	32		Inside Right of Way	Conflict Depending on Cover	2	2	Not Reimbursable
CC-06	Consolidated Communication	Fiber Line Underground	2	9	99+30	100+18	Rt	28		Inside Right of Way	Conflict Depending on Cover	2	2	Not Reimbursable
CC-07	Consolidated Communication	Fiber Line Underground	2	9	99+30	100+18	Rt	28		Inside Right of Way	Conflict Depending on Cover	2	2	Not Reimbursable
CC-08	Consolidated Communication	Fiber Line Underground	3	15	104+95	105+46	Lt	50		Inside Right of Way	Conflict Depending on Cover	2	2	Not Reimbursable
CC-09	Consolidated Communication	Fiber Line Underground	3	15	104+95	105+46	Lt	50		Inside Right of Way	Conflict Depending on Cover	2	2	Not Reimbursable
CC-10	Consolidated Communication	Fiber Line Underground	4	22	110+05	110+35	Lt	30		Outside Right of Way	Proposed Storm Sewer Conflict	1	1	Reimbursable

EXHIBIT A
Work Order for Project 77DND17037

Date: August 1, 2017

Project Name: SU-8-984(152)155

City: Fargo North Dakota

Address: City of Fargo
200 Third Street North
Fargo, ND 58102
Attn: Jeremy Engquist

Telephone: 701-298-6939

Consolidated:

Address: Consolidated Communications Enterprise Services, Inc.
121 South 17th St.
Mattoon, IL 61938
Attn: Ross Branstner

Telephone: 701-356-6004

Project Description:

City of Fargo 32nd Ave S. Road Project known as SU-8-984(152)155.

Consolidate Communications was required to relocate several existing utilities as part of the City of Fargo 32nd Ave S. Road Project SU-8-984(152)155 located in Fargo, ND along 32nd Ave S. Construction has been completed to relocate our utilities.

Work Order Estimate: \$26,310.00

EXHIBIT B
Insurance

Each party will maintain the following minimum insurance coverage:

- (a) Worker's compensation insurance covering all workers engaged in performance of the work for the Project in amounts not less than minimum coverage required by law, including employer's liability coverage of not less than \$500,000.00
- (b) Comprehensive general liability insurance. This insurance provides limits of not less than \$1,000,000.00 per occurrence and \$2,000,000 in aggregate.
- (c) Comprehensive Automobile Liability Insurance covering all owned, non-owned and hired vehicles, with limits of not less than \$1,000,000.00.

(33)

PUBLIC WORKS PROJECTS EVALUATION COMMITTEE

Improvement District No. BR-18-B1
 NHU-CPU-8-081(038)927, PCN 21168

Type: Approval of Project into 2018 CIP

Location: 10th Street N – 4th to 12th Avenue N

Date of Hearing: 10/16/2017

<u>Routing</u>	<u>Date</u>
City Commission	<u>10/23/2017</u>
PWPEC File	<u>X</u>
Project File	<u>Jeremy Gorden</u>

The committee reviewed communication from Transportation Division Engineer, Jeremy Gorden, regarding this project. Staff has been working diligently on this project for over a year but it has not formally been approved as part of a CIP. Staff is requesting that we approve this project as a standalone project now and also include it as part of the 2018 CIP that will be coming forward as a whole plan within the next month for City Commission approval. The reason we need to include it before the full 2018 CIP is approved is that it is being bid by the NDDOT on November 17 and we need to get the Special Assessment district created now.

This project will include full street reconstruction, replacement of water transmission line from 10th to 12th Avenue N, spot repairs of same line 4th to 10th Avenue N, replacement of local watermain, storm sewer system, and sanitary sewer mainline and services, replacement of storm sewer lift station within the underpass, replacement of the traffic signals, signing and striping, and spot repairs to existing sidewalk.

Funding for the project will consist of Federal Highway Funds from the NDDOT's Regional Highway System (Federal), NDDOT State Funds, Water Utility Funds, Sewer Utility Funds, and Special Assessment Funds (Local). The funding breakout is as follows:

Regional Highway System (Federal)	80% of Fed Aid Eligible	\$ 4,059,841
ND State Funds	10% of Fed Aid Eligible	\$ 507,480
Local Funds:		
Water Utility Funds (City)		\$ 746,718
Sewer Utility Funds (City)		\$ 230,150
Special Assessments – Water Main		\$ 537,775
Special Assessments – Street Reconstruction		\$ 1,152,348
Special Assessments – Sanitary Sewer		\$ 250,344

On a motion by Mark Bittner, seconded by Ben Dow, the Committee voted to recommend approval of adding the 10th Street Project, BR-18-B into the 2018 Capital Improvement Plan.

RECOMMENDED MOTION

Concur with the recommendations of PWPEC and approve the 10th Street reconstruction project into the 2018 Capital Improvement Plan.

PROJECT FINANCING INFORMATION:

Recommended source of funding for project: Federal, State, Special Assessments, Water Utility and Sewer Utility Funds

Developer meets City policy for payment of delinquent specials
 Agreement for payment of specials required of developer
 Letter of Credit required (per policy approved 5-28-13)

COMMITTEE

	Yes		No	
	Present	Yes	No	Unanimous
				<input checked="" type="checkbox"/>
Tim Mahoney, Mayor	<input checked="" type="checkbox"/>	<input checked="" type="checkbox"/>	<input type="checkbox"/>	
Jim Gilmour, Director of Planning	<input checked="" type="checkbox"/>	<input checked="" type="checkbox"/>	<input type="checkbox"/>	
Steve Dirksen, Fire Chief	<input checked="" type="checkbox"/>	<input checked="" type="checkbox"/>	<input type="checkbox"/>	Ryan Erickson
Mark Bittner, Director of Engineering	<input checked="" type="checkbox"/>	<input checked="" type="checkbox"/>	<input type="checkbox"/>	
Bruce Grubb, City Administrator	<input checked="" type="checkbox"/>	<input checked="" type="checkbox"/>	<input type="checkbox"/>	
Ben Dow, Director of Operations	<input checked="" type="checkbox"/>	<input checked="" type="checkbox"/>	<input type="checkbox"/>	
Steve Sprague, City Auditor	<input checked="" type="checkbox"/>	<input checked="" type="checkbox"/>	<input type="checkbox"/>	
City Engineer	<input checked="" type="checkbox"/>	<input checked="" type="checkbox"/>	<input type="checkbox"/>	Brenda Derrig
Kent Costin, Finance Director	<input checked="" type="checkbox"/>	<input checked="" type="checkbox"/>	<input type="checkbox"/>	

ATTEST:

C: Kristi Olson

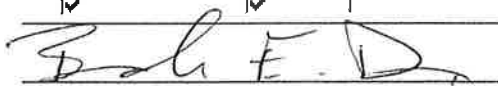
 Brenda E. Derrig, P.E.
 Division Engineer



ENGINEERING DEPARTMENT

200 3rd Street North
Fargo, North Dakota 58102
Phone: (701) 241-1545
Fax: (701) 241-8101
E-Mail: feng@cityoffargo.com

October 10, 2017

To: Members of PWPEC
From: Jeremy M. Gorden, PE, PTOE *JMG*
Division Engineer-Transportation
Subject: 2017 Capital Improvement Plan Revision
Improvement District No. BR-18-B1

Request to add the 10th Street N Street Reconstruction Project to the 2017 CIP Improvement District No. BR-18-B1 – 4th Avenue N to 12th Avenue N NDDOT Project No. NHU-CPU-8-081(038)927 PCN 21168

Since this project hasn't officially been included with a CIP, I'd like to add it to the 2017 CIP as it is set to be bid on November 17 by the NDDOT as well.

This project will include full street reconstruction, replacement of water transmission line from 10th to 12th Avenue N, spot repairs of same line 4th to 10th Avenue N, replacement of local water main, storm sewer system, and sanitary sewer mainline and services, replacement of storm sewer lift station within the underpass, replacement of the traffic signals, signing and striping, and spot repairs to existing sidewalk.

Funding for the project will consist of Federal Highway Funds from the NDDOT's Regional Highway System (Federal), NDDOT State Funds, Water Utility Funds, Sewer Utility Funds, Sales Tax Funds and Special Assessment Funds (Local). The project's cost breakout is as follows:

Estimated Construction Cost		\$6,672,529
Federal Aid Eligible (non-water and sewer items)		\$5,074,802
Water and Sewer Items		\$1,597,727
Engineering (NDDOT & Consultants)		\$ 680,000
Funding		
Regional Highway System (Federal)	80% of Fed Aid Eligible	\$4,059,841
ND State Funds	10% of Fed Aid Eligible	\$ 507,480
Local Funds – Remainder		\$2,785,207

This project is ready to be placed on the City Commission agenda for project creation and creation of Special Assessment District.

Recommended Motion

Approve the addition of Improvement District BR-18-B1 for 10th Street North reconstruction to the 2017 CIP.

JMG/klo

- Street Lighting
Sidewalks
- Design & Construction
Traffic Engineering
- Truck Regulatory
Flood Plain Mgmt.
- Mapping & GIS
Utility Locations

3A

PUBLIC WORKS PROJECTS EVALUATION COMMITTEE

Improvement District No. BR-18-B1
NHU-CPU-8-081(038)927, PCN 21168

Type: Amendment to Agreement for Reconstruction of Underpass

Location: 10th Street N – 4th to 12th Avenue N

Date of Hearing: 10/16/2017

Routing Date
City Commission 10/23/2017
PWPEC File X
Project File Jeremy Gorden

The committee reviewed communication from Transportation Division Engineer, Jeremy Gorden, regarding an amendment to an existing agreement for 10th Street at the BNSF underpass located between 4th Avenue N and 6th Avenue N. Back in 1938 when this underpass was first built, the maintenance agreement had language that the storm sewer lift station was to be owned and operated by the railroad and now we are changing that to read the storm sewer lift station will be newly constructed, and owned and operated by the City of Fargo. Staff has coordinated with the NDDOT and the BNSF Railway Company and is comfortable with the language and is recommending approval.

On a motion by Ben Dow, seconded by Steve Sprague, the Committee voted to recommend approval of the Amendment to the 1938 Agreement with the NDDOT and the BNSF Railway Company.

RECOMMENDED MOTION

Concur with the recommendations of PWPEC and approve the Amendment to the Agreement with the NDDOT and the BNSF Railway Company as a part of the street reconstruction project on 10th Street between 4th Avenue N and 12th Avenue N.

PROJECT FINANCING INFORMATION:

Recommended source of funding for project: N/A

Developer meets City policy for payment of delinquent specials
Agreement for payment of specials required of developer
Letter of Credit required (per policy approved 5-28-13)

Yes No
N/A
N/A
N/A

COMMITTEE

Table with 4 columns: Present, Yes, No, Unanimous. Rows list committee members: Tim Mahoney, Mayor; Jim Gilmour, Director of Planning; Steve Dirksen, Fire Chief; Mark Bittner, Director of Engineering; Bruce Grubb, City Administrator; Ben Dow, Director of Operations; Steve Sprague, City Auditor; City Engineer; Kent Costin, Finance Director. Includes handwritten initials and names like Ryan Erickson and Brenda Derrig.

ATTEST:

C: Kristi Olson

Handwritten signature of Brenda E. Derrig, P.E.
Brenda E. Derrig, P.E.
Division Engineer

October 11, 2017

To: Members of PWPEC

From: Jeremy M. Gorden, PE, PTOE *JMG*
Division Engineer-Transportation

Subject: Amendment to Agreement for Reconstruction of Underpass with BNSF Railway Company and North Dakota Department of Transportation
10th Street Reconstruction Project – 4th Avenue North to 12th Avenue North
City Improvement District No. BR-18-B1
NDDOT Project No. NHU-CPU-8-081(038)927 PCN 21168

I have received a three-way Agreement prepared by the NDDOT Local Government Division for amending an existing agreement between the City of Fargo, BNSF and the NDDOT dating back to 1938. As part of our street reconstruction project slated for bidding next month and under construction next year, we have included a new storm water lift station in the underpass between 4th Avenue North and 6th Avenue North that will replace the existing lift station. Currently, the existing lift station is owned and operated by the BNSF Railway Company and once our project is complete, we will have ownership and maintenance of a new lift station and the existing lift station will be removed as part of the project. Staff from all three entities have been working towards this Agreement over the past number of months and we are ready to have it officially approved now.

Recommended Motion

Approve the Amendment to the Agreement with NDDOT and BNSF Railway Company for the 10th Street reconstruction project.

JMG/jmg
Attachments



Richard Scott
Manager Public Projects
MN, ND, SD

BNSF Railway Company
80—44th Avenue NE
Minneapolis, MN 55421
Phone: (763) 782-3492
richard.scott2@bnsf.com

October 02, 2017

Ardin Striefel, NDDOT – Local Government
North Dakota Department of Transportation
608 East Boulevard Ave
Bismarck, ND 58505

Re: FARGO, ND ND-81/10TH ST UNDERPASS LIFT STATION RECONSTRUCTION
BNSF File No. BF10011815

Mr. Striefel:

Please find enclosed three (3) copies of the above referenced, BNSF reviewed and accepted agreement, ready for Execution by the City of Fargo and North Dakota Department of Transportation.

Please coordinate to have the City of Fargo sign each original copy of the agreement and then upon signature by the ND/DOT, please return one fully executed "Railroad Copy" of the agreement to BNSF at my address noted above.

Should you have any questions, please feel free to contact me.

Sincerely;

A handwritten signature in black ink, appearing to read "Richard Scott", with a long horizontal flourish extending to the right.

Richard Scott
BNSF Railway
Manager Public Projects
MN, ND, SD

North Dakota Department of Transportation
AMENDMENT TO AGREEMENT FOR RECONSTRUCTION OF UNDERPASS

Project No. FAGM 1
Tied to Current Project: NHU-8-081(038)927

THIS AMENDMENT to the agreement for the reconstruction of underpass for Project No. FAGM 1 is entered into by and between the State of North Dakota, acting through its Director of Transportation, hereinafter known as NDDOT, whose address is 608 East Boulevard Avenue, Bismarck, North Dakota 58505-0700, the City of Fargo, hereinafter known as the City, and BNSF Railway Company, hereinafter known as the Railroad, whose address is 80 - 44th Avenue NE, Minneapolis, Minnesota 55421.

WHEREAS, the parties entered into a contract on February 1, 1938 for Project No. FAGM 1 for the reconstruction of the 10th Street underpass located between 4th and 6th Avenue North. See attached agreement for Project No. FAGM1; and

WHEREAS, a lift station was installed at the 10th Street underpass to drain as needed.

WHEREAS, the Railroad has maintenance of the existing lift station, including the pump equipment, wiring, conduit, connections, controls, the well and motor house as noted in the attached agreement; and

WHEREAS, the City has noted that the existing lift station is inadequate and frequent flooding of the underpass occurs during rainfall events.

NOW THEREFORE, the City, Railroad, and NDDOT agree that the City shall make provisions for the design of a new lift station and provide plan sheets to the NDDOT for approval and incorporation into Project NHU-8-081(038)927. The plan sheets shall include the removal and replacement of the existing lift station, as shown on the attached layout. The City shall at its own cost and expense maintain the new lift station, including but not limited to, the pump equipment, wiring, conduit, connections, controls, and well. The City shall also pay for the electricity for the pump equipment and lighting system for the lift station.

The Railroad shall allow the Contractor to remove and replace the lift station at the locations shown on the attached layout sheet within the work area as shown. The Contractor shall comply with contractor requirements as detailed on the attached Exhibits A, B, C, D, and E. Also attached hereto are Exhibits F and G and by mention hereto are made a part hereof. This agreement constitutes approval of all work necessary to remove and replace the existing lift station as shown on the attached layout sheet.



All other terms and conditions of the above-referenced contract are incorporated herein by reference and remain in full force and effect.

EXECUTED the date last below signed.

WITNESS:

CALVIN NV77
NAME (TYPE OR PRINT)
[Signature]
SIGNATURE

BNSF RAILWAY COMPANY:

RICHARD SCOTT
NAME (TYPE OR PRINT)
[Signature]
SIGNATURE
MANAGER, PUBLIC PROJECTS
TITLE
10/02/2017
DATE

WITNESS:

NAME (TYPE OR PRINT)

SIGNATURE

CITY OF FARGO:

Timothy J. Mahoney
NAME (TYPE OR PRINT)

SIGNATURE
Mayor
TITLE

DATE

WITNESS:

NAME (TYPE OR PRINT)

SIGNATURE

NORTH DAKOTA DEPARTMENT OF TRANSPORTATION

DIRECTOR (TYPE OR PRINT)

SIGNATURE

DATE

APPROVED as to substance by:

DIVISION DIRECTOR (TYPE OR PRINT)

SIGNATURE

DATE

CLA 52494 (Div. 06)
L.D. Approved 5-19-00; 5-03; C.M. 07/25/2017



The Contractor, for work on or adjacent to the Railroad right-of-way, will indemnify and hold harmless the Railroad and any other railroad company occupying or using the Railroad's right-of-way or line of railroad against all loss, liability, and damage arising from activities of the Contractor, its forces or any of its subcontractors or agents, and will further provide the following insurance coverages:

- A. Before commencing any work under this agreement, Contractor must provide and maintain in effect insurance, at Contractor's expense, covering all of the work and services to be performed hereunder by the Contractor and each of its subcontractors, as described below.
 - 1. Worker's Compensations coverage is as required by state law. If the Contractor is not covered by the North Dakota Workers Comp Act, the Contractor shall provide employers liability policy. The certificate for this policy must contain a specific waiver of the insurance company's subrogation rights against the BNSF Railway Company.
 - 2. Commercial general liability insurance covering liability, including but not limited to public liability, personal injury and property damage, with coverage of at least \$2,000,000 per occurrence and \$6,000,000 in the aggregate. Where explosion, collapse, or underground hazards are involved, the X, C and U exclusions in Marsh requirements. See Exhibit F concerning limited seepage, pollution, and contamination coverage.
 - 3. Automobile liability insurance, including bodily injury and property damage, with coverage of at least \$1,000,000 combined single limit or the equivalent.
 - 4. Contractual liability insurance covering all of the liability assumed by the Contractor under the provisions of this agreement, with coverage of at least \$2,000,000 combined single limit or the equivalent.
 - 5. Railroad protective liability insurance stating the BNSF Railway Company is the named insured covering all of the liability assumed by the Contractor under the provisions of this agreement with coverage of at least \$5,000,000 per occurrence and \$10,000,000 in the aggregate.

All insurance shall be placed with insurance companies licensed to do business in the states in which the work is to be performed, and with current Best's Insurance Guide Ratings of A and Class X, or better.

If any work is to be performed within 50 feet of a railroad track, then insurance must provide coverage of incidents occurring within fifty (50) feet of a railroad track, and any provision to the contrary in the insurance policy must be specifically deleted.

In all cases, the certificate must specifically state that BNSF Railway Company is an additional insured.

Any coverage afforded Railroad, the Certificate Holder, as an additional insured shall apply as primary and not excess to any insurance issued in the name of the Railroad.

Exhibit A

- B. Before commencing any work hereunder, the Contractor shall furnish to Railroad, and the Railroad will approve, Certificate of Insurance on the form prescribed by Railroad, evidencing the issuance to the Contractor of the policies of insurance providing the types of less than 30 days written notice prior to any material change, substitution or cancellation prior to normal expiration dates. Cancellation or expiration of any of said policies of insurance shall not preclude Railroad from recovery there under for any liability arising under this agreement.
- C. It is mutually understood and agreed that the purchase of insurance as herein provided shall not in any way limit the liability of the Contractor to Railroad, as herein set forth.

The following information must appear on the Certificate of Insurance to identify the project policy is issued to cover:

Project: BNSF Railway Bridge over I-94 over BNSF Railway, Jamestown, ND

Contractor:

Name:
Address:
Telephone Number:

BNSF Railway:

Railroad protective insurance may be obtained from:

MARSH
(214) 303-851

Certificate of Insurance should be sent to:

BNSF Manager of Public Projects 80-44th Avenue NE
Minneapolis MN 55421
(763) 782-3492

REQUIREMENTS FOR CONTRACTORS WORKING ON RAILROAD RIGHT-OF-WAY

The North Dakota Department of Transportation and City agrees to not allow their contractors to occupy or work on the railroad's right-of-way prior to signing the Road Authority's contract, which shall include the following list of conditions:

1. All permits and agreements must be in effect, required payments made and insurance certificates received and approved prior to entering railroad right-of-way.
2. Contractor's approved insurance must be in effect prior to entry onto railroad right-of-way and during entire Project.
3. No change will be made to "Construction Plans" without approval by all parties involved. Approved revised plans will be furnished to all parties prior to implementation of changes.
4. Road authority or contractor will incur all costs for track work, including flagging, etc., made necessary due to their construction operation.
5. Flagging protection is always required when equipment crosses or is working within 25 feet of center of any live track. When deemed necessary by railroad officers, a flagman may be required at all times while working on railroad right-of-way in high density rail traffic areas.
6. Crossing of any railroad tracks must be done at approved locations and must be over full depth timbers, rubber, etc. Any equipment with steel wheels, lugs or tracks, must not cross steel rails without aid or rubber tires or other approved protection.
7. All track crossing locations must be covered by a private roadway and crossing agreement.
8. Contractor must furnish details on how he will perform work that will affect existing drainage and/or possible fouling of track ballast, as well as removal of permanent or temporary overhead bridges/structures. (Structures and bridge spans over tracks must be removed intact whenever possible).
9. Absolutely no construction will be allowed within 25 feet of center of any track unless authorized by the Railroad and shown on plan approved by the Railroad. This includes any excavation, slope encroachment and driving of sheet piles.
10. No vehicles or machines shall remain unattended while on railroad right of way.
11. **IMPORTANT:** Disregarding any of these items will result in contractor's right of entry on railroad right-of-way being suspended for a minimum of 48 hours while infraction is investigated. Based on findings of the investigation, it will be determined if the contractor will be allowed to work on railroad right-of-way in the future.

12. Contractors' safety rules, including rules regarding personal safety equipment, must not conflict with the railroads safety policies or rules.
13. No employee of the Contractor, its subcontractors, agents or invitees may enter Railroad property without first having completed Railroad's Engineering Contractor Safety Orientation found on the web site www.BNSFcontractor.com. The Contractor must ensure that each of its employees, subcontractors, agents or invitees completes Railroad's Engineering Contractor Safety Orientation through internet sessions before any work is performed on the Project. Additionally, the Contractor must ensure that each and every one of its employees, subcontractors, agents or invitees possesses a card certifying completion of the Railroad Contractor Safety Orientation before entering Railroad Property. The Contractor is responsible for the cost of the Railroad Contractor Safety Orientation. The Contractor must renew the Railroad Contractor Safety Orientation annually. Further clarification can be found on the web site or from the Railroad's Representative.

CONTRACTOR'S ACKNOWLEDGMENT:

By their signature on the North Dakota Department of Transportation's contract, the contractor has agreed to abide by all the conditions listed above.

GENERAL SAFETY REQUIREMENTS FOR CONSULTANTS/CONTRACTORS

Work in the proximity of a railroad track is potentially dangerous. Employees and contract employees of consultants/contractors are governed by the following safety rules and general safety requirements while on railroad property. Consultant/contractor is responsible for enforcement of these rules and requirements. Railroad has the right to bar consultant/contractor employees and its contracted employees from working on railroad property if railroad deems such employees are unsafe workers. Consultant/contractor is also responsible for compliance with federal and state laws and any government regulations.

Safety rules cannot be all-inclusive. Workers must refrain from unsafe and improper practices, including both the violation of written rules and regulations and rules of common sense.

1. The use of alcoholic beverages, intoxicants, narcotics, or other controlled substances by employees subject to duty or their possession or use while on duty or on railroad property is prohibited. Workers must not report for duty under the influence of any alcoholic beverage, intoxicant, narcotic, marijuana or other controlled substance, or medication, including those prescribed by a doctor, that may in any way adversely affect their alertness, coordination, reaction, response or safety.
2. Scuffling, horseplay, practical jokes and all conduct of a similar nature is prohibited.
3. All vehicle accidents resulting in damage to railroad property will be reported immediately to the railroad engineer.
4. Employees are prohibited from having firearms or other deadly weapons, including knives with a blade in excess of three inches, in their possession while on duty or on company property, except those authorized to have them in the performance of their duties or those given special permission.
5. Good housekeeping is of the utmost importance in the prevention of accidents, injuries, and fires. Clean-up will be conducted on a daily basis.
6. Tools or work materials must not be left in close proximity to tracks.
7. Throwing waste, garbage, bottles, refuse, or other such materials on railroad property or disposing of such at other than designated locations is prohibited. Each contractor will provide refuse containers at the work site and empty them on a daily basis.
8. Objects which constitute a slipping or tripping hazard must not be left in walking areas.
9. Open fires or fires in barrels are not allowed on railroad property unless appropriate permits are acquired.
10. In all cases, established route of travel in and about property must be used.

11. Railroad vehicles have an unquestioned right-of-way in all circumstances relating to work on or about the track area.
12. Workers must not wear or use anything which impairs vision or hearing. Listening to personal radios or tape players is prohibited while on duty.
13. Upon entering work site, shoes or sturdy construction and proper height to provide adequate protection and hard hats are required. Other appropriate safety equipment (glasses, goggles, gloves, side shields) must be worn when OSHA or other railroad regulations require.
14. All employees will become familiar with and be capable of recognizing railroad equipment adjacent to the tracks.
15. Walking, stepping or standing on rail or ties, or sitting on any part of track structure except in performance of duty is prohibited. NOTE: The term "track structure" means the space between the rails and within three feet outside the rails, unless otherwise specified.
16. Workers are prohibited from tampering with switches or any other railroad equipment unless it is necessary for work operation and only in the presence of an authorized railroad worker.
17. Workers must not go underneath rail cars. They must not occupy rail cars except in performance of their duty.
18. Workers must not cross tracks by crossing over between cars that are coupled together.
19. Workers must not attempt to catch onto or ride any moving railroad equipment, even though it may be moving slowly.
20. Workers must not take refuge from rain, heat, etc., under or in cars or other rail equipment.
21. Workers are warned that trains, locomotives or cars, may be expected at any time, on any track, in either direction, and that they must watch for and keep clear of such movements. Workers must take extra precaution to be on the lookout for approaching trains, especially when working in multiple track territory, when field of vision is limited, or when noisy equipment is in use. A portable air horn shall be used by a designated person to warn workers of approach trains or equipment.
22. Workers shall not work on the track, between tracks in multiple track territory, or nearer than 25 feet to the track without proper flag protection provided by railroad.

23. Any work within 25 feet of rail without consideration to height must be stopped in the clear when trains are approaching and passing. The machine operator and workers must stand back at least 25 feet from the track. If the 25-foot distance cannot be attained, workers must clear the tracks as far as possible.
24. Work in tunnels, on bridges and overpasses must be done in accordance with a safety plan agreed upon by the railroad engineer or his representative prior to beginning work in these areas. When work is being done in tunnels, specific requirements must be met and work done under the railroad's supervision.
25. Do not wave arms or objects violently except in an emergency, this is a STOP signal.
26. Workers must not make any movement toward an approaching train or operate machinery in a manner that would cause the engineer to believe that the track is going to be fouled.
27. Crossing tracks immediately in front of moving equipment is prohibited.
28. When necessary to cross any track, look both ways and keep at least 25 feet from the nearest end of stationary rail cars.
29. Machines may be operated across tracks only at established grade crossings. If it is necessary to do so at any other location, it may be done only with permission of and under the supervision of the railroad engineer or his representative on site.
30. Some rails are conductors of electrical current and are integral parts of the railroad's operating system. Devices that could shunt this electrical current must not be laid across rails. No hand or portable tools will be left on the rails at any time. Use a wooden lath to provide separation when making measurements adjacent to the tracks.
31. Machines or vehicles must not be left unattended with the engine running. If a machine is left unattended, it must be in gear with brakes set. If it is equipped with blade, pan or bucket, that must be lowered to the ground.
32. All machinery and equipment left unattended on the right-of-way must be left inoperable and secured against movement.
33. When leaving work site areas at night and over weekends, the areas must be left in a condition that will ensure that railroad employees who might be working in the area are protected from all hazards. Any pen pits or holes shall be covered securely and a physical barrier such as a fence placed around the opening.
34. Machinery or equipment shall not be stored or left temporarily near a highway grade crossing in such a manner as to interfere with the sight distances of persons approaching that crossing. Prior to beginning work, contractor, with concurrence of the railroad engineer or his representative on site, will establish a storage area.

35. Cutting or knocking down trees or moving rocks and other materials that might fall on the track structure or on communications or power lines is prohibited, unless done with the approval and supervision of the railroad engineer or his representative.
36. Workers must not create and leave any condition at the work site that would interfere with water drainage.
37. Safeguards and safety signs must be kept in place and in good condition. It is the responsibility of the contractor to provide same.
38. Each person in charge of a work party must be familiar with the mile post location of the area in which work is being performed so that in cases of emergencies the exact location may be given to railroad personnel.
39. In cases of emergency, it may be necessary for contractor's employees or agents to flag and stop approaching trains. Flagging equipment should consist of red fuses and/or red flags.
40. When emergency flagging is necessary, workers should protect against trains moving in both directions.
41. When required to perform emergency flagging, workers must understand that a great distance is required in which to stop a moving train. The flag person must be at least 1.5 miles from the point being protected in order to provide minimum distance for the engineer to stop the train.

A stop signal is given by swinging the lighted fuse or red flag at right angle to the track, but the engineer will recognize the stop signal if given violently in any manner from a point near the track. Workers, when giving a stop signal, must not stand on or within fouling distance of the track, as normally the engineer will not have the required stopping distance to stop short of the point where the signal is being given.
42. When an emergency exists or if any hazard is noticed on passing trains, the railroad engineer or his representative on site must be notified immediately.
43. High frequency radios (not CB's) shall be used by all crews for emergency communications between crews.
44. Radio transmitters must not be operated when located less than 250 feet from blasting operations.
45. When it is necessary to create a hazardous condition in performing work on or in the vicinity of a track, proper protection must be afforded in accordance with a safety plan submitted to and approved by the Railroad Engineer or his representative prior to creating the hazardous condition, as well as taking any other precautions that may be necessary to protect the condition.

46. Before excavating, it must be ascertained by the contractor if there are underground electric wires, cables, or pipe lines in the vicinity.
47. If obstructions are encountered that do not appear on drawings, the railroad crew chief must be notified before continuing excavation operations.
48. All excavations, regardless of depth, will be shored where there is any danger to track structure.
49. No excavation will be left uncovered or unprotected overnight.
50. Holes or trenches in the vicinity of the track must be covered, upgraded, and protected, when not being worked on.
51. Excavations, trenches or pits on or adjacent to public roads will be physically protected and denoted by highway barriers with flashing lights when not in use.
52. All excavations will be backfilled as soon as possible
53. All power line wires must be considered dangerous and of high voltage unless informed to the contrary by proper authority. For lines rated 50KV or below, minimum clearance between the lines and any part of the equipment or load shall be 10 feet. For lines rated over 50KV, minimum clearance between the line and any part of equipment or load shall be 10 feet plus 0.4 inches for each 1KV over 50KV. If the capacity of the line is not known, minimum clearance of 20 feet must be maintained. A person shall be designated to observe clearance of the equipment and give a timely warning for all operations where it is difficult for operator to maintain the desired clearance by visual means.
54. IN ALL CASES OF DOUBT OR UNCERTAINTY, THE SAFEST COURSE MUST BE TAKEN.

FLAGGING REQUIREMENTS
FOR CONSTRUCTION PROJECTS ON OR ADJACENT TO PROPERTY OF
THE BURLINGTON NORTHERN AND SANTA FE RAILWAY COMPANY

SECTION 1. PROTECTION OF RAILWAY FACILITIES AND RAILWAY FLAGGER SERVICES

(a). The Contractor shall give a minimum of at least thirty (30) working days' notice to the Railways Roadmaster at telephone 701-227-7235 in advance of when flagging services will be required to bulletin the flaggers position and shall provide five (5) working days' notice to the Roadmaster to abolish the position per union requirements.

(b). Railway flagger and protective services and devices will be required and furnished when Contractor's work activities are located over or under of and within twenty-five (25) feet measured horizontally from center line of the nearest track and when cranes or similar equipment positioned outside of 25-foot horizontally from track center line that could foul the track in the event of tip over or other catastrophic occurrence, but not limited thereto for the following conditions:

(1). When in the opinion of the Railway's representative, it is necessary to safeguard Railway's Property employees, trains, engines and facilities.

(2). When any excavation is performed below the bottom of the elevation, if, in the opinion of Railway's representative, track or other Railway facilities may be subject to movement or settlement.

(3). When work in any way interferes with the safe operation of trains at timetable speeds.

(4). When any hazard is presented to Railway track, communications, signal, electrical, or other facilities either due to persons, materials, equipment or blasting in the vicinity.

(5). Special permission must be obtained from the Railway before moving heavy or cumbersome objects or equipment which might result in making the track impassable.

(c). Flagging services will be performed by qualified Railway flaggers. The base cost for (1) flagger is \$600.00 for an 8-hour day which includes vacation allowance, paid holidays, Railway and Unemployment Insurance, Public Liability and Property Damage Insurance, health and welfare benefits, transportation, meals, lodging and supervision, for an eight (8) hour basic day with time and one-half or double time for overtime, rest days and holidays. These rates are subject to any increases which may result from Railway Employees- Railway Management negotiations or which may be authorized by Federal authorities. State/Contractor will be billed on actual costs in effect at time work is performed.

(1). A flagging crew generally consists of one employee. However, additional personnel may be required to protect Railway Property and operations, if deemed necessary by the Railway's representative.

(2). Each time a flagger is called, the minimum period of billing shall be the eight (8) hour basic day.

(3). The cost of flagger services provided by the Railway, when deemed necessary by the Railway's representative, will be borne by the State/Contractor.

(4). The average train traffic per 24-hour period on this route is 44 trains at a timetable speed of 35 MPH.

NONDISCRIMINATION CLAUSES

During the performance of this contract, the Contractor, for itself, its assignees, and successors in interest (hereinafter referred to as the Contractor) agrees as follows:

1. Compliance with Regulations: The Contractor (hereinafter includes consultants) will comply with the Acts and the Regulations relative to Non-discrimination in Federally-assisted programs of the U.S. Department of Transportation, the Federal Highway Administration, as they may be amended from time to time, which are herein incorporated by reference and made a part of this contract.
2. Non-discrimination: The Contractor, with regard to the work performed by it during the contract, will not discriminate on the grounds of race, color, or national origin in the selection and retention of subcontractors, including procurements of materials and leases of equipment. The Contractor will not participate directly or indirectly in the discrimination prohibited by the Acts and the Regulations, including employment practices when the contract covers any activity, project, or program set forth in Appendix B of 49 CFR Part 21.
3. Solicitations for Subcontracts, Including Procurements of Materials and Equipment: In all solicitations, either by competitive bidding, or negotiation made by the Contractor for work to be performed under a subcontract, including procurements of materials, or leases of equipment, each potential subcontractor or supplier will be notified by the Contractor of the Contractor's obligations under this contract and the Acts and the Regulations relative to Non-discrimination on the grounds of race, color, or national origin.
4. Information and Reports: The Contractor will provide all information and reports required by the Acts, the Regulations, and directives issued pursuant thereto and will permit access to its books, records, accounts, other sources of information, and its facilities as may be determined by the Recipient or the Federal Highway Administration to be pertinent to ascertain compliance with such Acts, Regulations, and instructions. Where any information required of a Contractor is in the exclusive possession of another who fails or refuses to furnish the information, the Contractor will so certify to the Recipient or the Federal Highway Administration as appropriate, and will set forth what efforts it has made to obtain the information.
5. Sanctions for Noncompliance: In the event of a contractor's noncompliance with the Nondiscrimination provisions of this contract, the Recipient will impose such contract sanctions as it or the Federal Highway Administration may determine to be appropriate, including, but not limited to:
 - a. withholding payments to the Contractor under the contract until the Contractor complies; and/or
 - b. cancelling, terminating, or suspending a contract, in whole or in part.

6. Incorporation of Provisions: The Contractor will include the provisions of paragraphs one through six in every subcontract, including procurements of materials and leases of equipment, unless exempt by the Acts, the Regulations and directives issued pursuant thereto. The Contractor will take action with respect to any subcontract or procurement as the Recipient or the Federal Highway Administration may direct as a means of enforcing such provisions including sanctions for noncompliance. Provided, that if the Contractor becomes involved in, or is threatened with litigation by a subcontractor, or supplier because of such direction, the Contractor may request the Recipient to enter into any litigation to protect the interests of the Recipient. In addition, the Contractor may request the United States to enter into the litigation to protect the interests of the United States.

Pertinent Non-Discrimination Authorities:

- Title VI of the Civil Rights Act of 1964 (42 U.S.C. § 2000d *et seq.*, 78 stat. 252), (prohibits discrimination on the basis of race, color, national origin); and 49 CFR Part 21.
- The Uniform Relocation Assistance and Real Property Acquisition Policies Act of 1970, (42 U.S.C. § 4601), (prohibits unfair treatment of persons displaced or whose property has been acquired because of Federal or Federal-aid programs and projects);
- Federal-Aid Highway Act of 1973, (23 U.S.C. § 324 *et seq.*), (prohibits discrimination on the basis of sex);
- Section 504 of the Rehabilitation Act of 1973, (29 U.S.C. § 794 *et seq.*), as amended, (prohibits discrimination on the basis of disability); and 49 CFR Part 27;
- The Age Discrimination Act of 1975, as amended, (42 U.S.C. § 6101 *et seq.*), (prohibits discrimination on the basis of age);
- Airport and Airway Improvement Act of 1982, (49 USC § 471, Section 47123), as amended, (prohibits discrimination based on race, creed, color, national origin, or sex);
- The Civil Rights Restoration Act of 1987, (PL 100-209), (Broadened the scope, coverage and applicability of Title VI of the Civil Rights Act of 1964, The Age Discrimination Act of 1975 and Section 504 of the Rehabilitation Act of 1973, by expanding the definition of the terms "programs or activities" to include all of the programs or activities of the Federal-aid recipients, sub-recipients and contractors, whether such programs or activities are Federally funded or not);
- Titles II and III of the Americans with Disabilities Act, which prohibit discrimination on the basis of disability in the operation of public entities, public and private transportation systems, places of public accommodation, and certain testing entities (42 U.S.C. §§ 12131-12189) as implemented by Department of Transportation regulations at 49 C.F.R. parts 37 and 38;
- The Federal Aviation Administration's Non-discrimination statute (49 U.S.C. § 47123) (prohibits discrimination on the basis of race, color, national origin, and sex);

- Executive Order 12898, Federal Actions to Address Environmental Justice in Minority Populations and Low-Income Populations, which ensures discrimination against minority populations by discouraging programs, policies, and activities with disproportionately high and adverse human health or environmental effects on minority and low-income populations;
- Executive Order 13166, Improving Access to Services for Persons with Limited English Proficiency, and resulting agency guidance, national origin discrimination includes discrimination because of limited English proficiency (LEP). To ensure compliance with Title VI, you must take reasonable steps to ensure that LEP persons have meaningful access to your programs (70 Fed. Reg. at 74087 to 74100);
- Title IX of the Education Amendments of 1972, as amended, which prohibits you from discriminating because of sex in education programs or activities (20 U.S.C. 1681 et seq).

**LIMITED SEEPAGE, POLLUTION AND CONTAMINATION COVERAGE
ENDORSEMENT WORDING**

In consideration of the premium charged for the policy provided by Marsh, it is understood and agreed that Exclusion of Coverage A of this policy shall not apply to the liability of the insured resulting from seepage and/or pollution and/or contamination caused solely by:

- a. unintended fire, lightning or explosion: or
- b. a collision or overturning of a road vehicle: or
- c. a collision or overturning or derailment of a train.

Notwithstanding the foregoing it is agreed that the coverage provided by this endorsement shall not apply to:

- 1. loss of, damage to or loss of use of property directly or indirectly resulting from sub-surface operations of the insured, and/or removal of, loss of or damage to sub-surface oil, gas or any other substance;
- 2. any site or location used in whole or in part for the handling, processing, treatment, storage, disposal or dumping of any waste materials or substances;
- 3. the cost of evaluating and/or monitoring and/or controlling seeping and/or polluting and/or contaminating substances;
- 4. the cost of removing and/or nullifying and/or cleaning up seeping and/or polluting and/or contaminating substances on property at any time owned and/or leased and/or rented by the insured and/or under the control of the insured.

Notwithstanding the foregoing, Item 1 does not apply to tunnels.

If railroad protective insurance is obtained from a different insurance carrier, the preceding provisions must be incorporated into the policy.

Railroad Cost Estimate

The cost to complete the work performed by the railroad as identified in Section IIIB is as follows:

1. Flagger as per Exhibit D = \$30,000

Payment to the Railroad will be made by the NDDOT upon receipt of a request for payment from the Railroad. The request for payment shall be made to:

North Dakota Department of Transportation
Jon Ketterling, Bridge Engineer
608 East Boulevard Avenue
Bismarck ND 58501-0700

COVER SHEET
CITY OF FARGO PROJECTS

(35-1)

This sheet must be completed and turned in with all City of Fargo projects. NO items will be accepted by either the City Commission Office or the City Auditor's Office without this cover sheet attached and properly filled out.

Exact, full name of Improvement District as it will appear in the Contract:

PC CONCRETE PAVEMENT, STORM SEWER, WATERMAIN, SANITARY SEWER, LIFT STATION, SIDEWALK, TRAFFIC SIGNALS & INCIDENTALS

Improvement District No. BR-18-B

Call For Bids October 23, 2017

Advertise Dates October 30 & November 6, 2017

Bid Opening Date (NDDOT) November 17, 2017

Substantial Completion Date September 28, 2018

Final Completion Date October 28, 2018

N/A PWPEC Report (Part of 2018 CIP)

X Engineer's Report (Attach Copy)

N/A Direct City Auditor to Advertise for Bids (to be bid by NDDOT)

N/A Bid Quantities (Attach Copy for Auditor's Office Only)

X Notice to Property Owners (Dan Eberhardt)

Project Engineer Jeremy Gorden

Phone No. 241-1545

The items listed above are for use on all City projects. The additional items listed below are to be checked only when all or part of a project is to be special assessed:

X Create District (Attach Copy of Legal Description)

X Order Plans & Specifications

X Approve Plans & Specifications

X Adopt Resolution of Necessity

N/A Approve Escrow Agreement (Attach Copy for Commission Office Only)

X Assessment Map (Attach Copy for Auditor's Office Only)

ENGINEER'S REPORT

PC CONCRETE PAVEMENT, STORM SEWER, WATERMAIN, SANITARY SEWER, LIFT
STATION, SIDEWALK, TRAFFIC SIGNALS & INCIDENTALS

IMPROVEMENT DISTRICT NO. BR-18-B

Nature and Scope

This project is for the pavement reconstruction on 10th Street from 4th to 12th Avenue North. It provides for the replacement of the cast iron water main, replacement of the water transmission pipe between 10th Avenue and 12th Avenue N, the sanitary sewer, installation of new storm sewer including a new lift station in the underpass, replacement of the traffic signals, and spot repairs to the existing sidewalk.

This project was approved by the Fargo City Commission under the 2018 Capital Improvements Program (CIP) and the project's federally mandated environmental document was approved by the Fargo City Commission last April.

Purpose

10th Street North is an arterial street that services North Fargo and is part of the NDDOT Regional Highway System. The existing street section is deteriorated and in need of replacement. The sewer and water main replacement portions of the project will replace deteriorated mains and service piping that will be located under the new street section.

Feasibility

The estimated construction cost is approximately \$6,061,046 (\$3,660,790 Fed/\$410,272 State/\$1,990,000 Local). Funding for the project will consist of Federal Highway Funds from the NDDOT's Regional Highway System, NDDOT State Funds, Watermain Replacement Funds, Water Utility Funds, Sewer Utility Funds and Special Assessment Funds (Local). The project's cost breakout is as follows:

Water Main Cost

Assessed Water Main Construction Cost	\$ 439,483
Plus Fees:	
4% Engineering:	\$ 17,579
6% Administration:	\$ 26,369
7% Miscellaneous:	\$ 30,763
4% Interest:	\$ 17,579
Consulting Engineering Fee – Preliminary and Final Design	<u>\$ 6,000</u>
 Total Estimated Water Main Assessed Cost	 \$ 537,775
 City Funded Water Main Construction Cost	 \$ 439,483
Plus Fees:	
4% Engineering:	\$ 17,579
7% Miscellaneous:	\$ 30,763
4% Interest	\$ 17,579
Consulting Engineering Fee – Preliminary and Final Design	<u>\$ 6,000</u>
 Total Estimated City Funded Water Main Cost (WM Replacement Funds)	 \$ 511,406

Total Estimated Water Main Cost: \$ 1,049,181

Water Transmission Cost

City Funded Water Transmission Construction Cost \$ 217,020
Plus Fees:
4% Engineering: \$ 8,680
7% Miscellaneous: \$ 15,191
4% Interest \$ 8,680
Consulting Engineering Fee – Preliminary and Final Design \$ 12,000

Total Estimated City Funded Water Transmission Cost (Water Utility Funds) \$ 261,573

Street Reconstruction Cost

Assessed Street Reconstruction Construction Cost \$ 539,131
Plus Fees:
4% Engineering: \$ 21,565
6% Administration: \$ 32,347
7% Miscellaneous: \$ 37,739
4% Interest: \$ 21,565
Right-of-Way \$ 200,000
Utility Relocations \$ 100,000
Consulting Engineering Fee – Preliminary and Final Design \$ 100,000
Consulting Engineering Fee – Construction Services \$ 100,000
Total Estimated Assessed Street Reconstruction Cost \$ 1,152,348

Federal & State Funded Street Reconstruction Construction Cost \$ 4,478,169
Total Estimated Fed & State Funded Street Reconstruction Cost: \$ 4,478,169

Total Estimated Street Reconstruction Cost: \$ 5,630,517

Sanitary Sewer Cost

Assessed Sanitary Sewer Construction Cost \$ 201,937
Plus Fees:
4% Engineering: \$ 8,077
6% Administration: \$ 12,116
7% Miscellaneous: \$ 14,135
4% Interest: \$ 8,077
Consulting Engineering Fee – Preliminary and Final Design \$ 6,000

Total Estimated Sanitary Sewer Assessed Cost \$ 250,344

City Funded Sanitary Sewer Construction Cost \$ 201,937
Plus Fees:
4% Engineering: \$ 8,077
7% Miscellaneous: \$ 14,135
4% Interest \$ 8,077
Consulting Engineering Fee – Preliminary and Final Design \$ 6,000

Total Estimated City Funded Sanitary Sewer Cost \$ 238,228

Total Estimated Sanitary Sewer Cost: \$ 488,573

Estimated Project Cost

\$ 7,429,846

Project Funding Summary

NDDOT Regional Highway System Funds (Federal)	\$ 4,026,869
NDDOT State Funds	\$ 451,299
Watermain Replacement Funds (City)	\$ 511,406
Water Utility Funds (City)	\$ 261,573
Sewer Utility Funds (City)	\$ 238,228
Special Assessments – Water Main	\$ 537,775
Special Assessments – Street Reconstruction	\$ 1,152,348
Special Assessments – Sanitary Sewer	\$ 250,344

Costs will be special assessed according to City policy.

We believe this project to be cost effective.



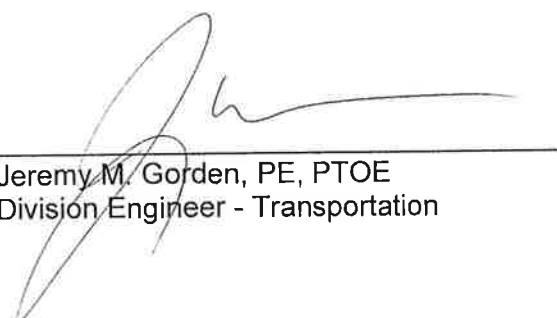

Jeremy M. Gorden, PE, PTOE
Division Engineer - Transportation

October 2017

Engineer's Opinion of Cost

ND DOT Project No. NHU-CPU-8-081(038)927 PCN 21168

10th Street N from 4th Avenue N to 12th Avenue N

City of Fargo Improvement District No. BR-18-B

October 11, 2017

Spec	Code	Item Description	Unit	Quantity	Unit Cost	Total Cost
103	100	CONTRACT BOND	L SUM	0.7	\$ 32,900.00	\$ 23,030.00
201	370	REMOVAL OF TREES 10IN	EA	3	\$ 325.00	\$ 975.00
201	380	REMOVAL OF TREES 18IN	EA	3	\$ 450.00	\$ 1,350.00
201	390	REMOVAL OF TREES 30IN	EA	13	\$ 700.00	\$ 9,100.00
202	111	REMOVAL OF CONCRETE	L SUM	1	\$ 5,000.00	\$ 5,000.00
202	136	REMOVAL OF PAVEMENT	TON	15,237.00	\$ 12.25	\$ 186,653.25
202	174	REMOVAL OF PIPE ALL TYPES AND SIZES	LF	2,937.00	\$ 14.65	\$ 43,027.05
202	208	REMOVAL OF ABUTMENTS	L SUM	1	\$ 10,000.00	\$ 10,000.00
202	210	REMOVAL OF MANHOLES	EA	17	\$ 1,034.00	\$ 17,578.00
202	230	REMOVAL OF INLETS	EA	24	\$ 650.00	\$ 15,600.00
202	277	REMOVAL OF LIFT STATION	L SUM	1	\$ 20,000.00	\$ 20,000.00
202	292	REMOVAL OF EXISTING RETAINING WALL	L SUM	1	\$ 10,000.00	\$ 10,000.00
203	101	COMMON EXCAVATION-TYPE A	CY	2,082.00	\$ 6.00	\$ 12,492.00
203	109	TOPSOIL	CY	1,345.00	\$ 4.50	\$ 6,052.50
216	100	WATER	M GAL	237	\$ 23.50	\$ 5,569.50
251	300	SEEDING CLASS III	ACRE	1.736	\$ 1,300.00	\$ 2,256.80
251	2000	TEMPORARY COVER CROP	ACRE	1.736	\$ 250.50	\$ 434.87
253	201	HYDRAULIC MULCH	ACRE	1.736	\$ 1,610.00	\$ 2,794.96
255	103	ECB TYPE 3	SY	601	\$ 2.44	\$ 1,466.44
302	100	SALVAGED BASE COURSE	TON	11,108.00	\$ 15.00	\$ 166,620.00
550	302	8.5IN NON-REINF CONCRETE PVMT CL AE-DOWELED	SY	2,437.00	\$ 60.00	\$ 146,220.00
550	307	9.5IN NON-REINF CONCRETE PVMT CL AE-DOWELED	SY	9,995.00	\$ 60.00	\$ 599,700.00
602	130	CLASS AAE-3 CONCRETE	CY	261	\$ 1,069.00	\$ 279,009.00
602	1130	CLASS AE-3 CONCRETE	CY	41.8	\$ 1,500.00	\$ 62,700.00
602	7000	SPECIAL SURFACE FINISH	SF	9,700.00	\$ 5.00	\$ 48,500.00
612	115	REINFORCING STEEL-GRADE 60	LBS	2,505.00	\$ 2.00	\$ 5,010.00
624	123	PEDESTRIAN RAILING	LF	120.7	\$ 250.00	\$ 30,175.00
624	151	RAILING	LF	1,131.00	\$ 107.50	\$ 121,582.50
702	100	MOBILIZATION	L SUM	0.7	\$ 364,110.00	\$ 254,877.00
704	100	FLAGGING	MHR	280	\$ 35.75	\$ 10,010.00
704	1000	TRAFFIC CONTROL SIGNS	UNIT	6,097.00	\$ 1.65	\$ 10,060.05
704	1052	TYPE III BARRICADE	EA	70	\$ 86.00	\$ 6,020.00
704	1055	PEDESTRIAN LONGITUDINAL BARRICADE	LF	540	\$ 8.00	\$ 4,320.00
704	1057	PEDESTRIAN DETECTABLE EDGE	LF	1,009.00	\$ 2.00	\$ 2,018.00
704	1060	DELINEATOR DRUMS	EA	67	\$ 24.40	\$ 1,634.80
704	1067	TUBULAR MARKERS	EA	10	\$ 9.29	\$ 92.90
704	1072	FLEXIBLE DELINEATORS	EA	69	\$ 42.80	\$ 2,953.20
704	1087	SEQUENCING ARROW PANEL-TYPE C	EA	1	\$ 1,643.00	\$ 1,643.00
704	1500	OBLITERATION OF PAVEMENT MARKING	SF	5,467.00	\$ 2.30	\$ 12,574.10
704	2108	TEMPORARY CURB RAMP	EA	23	\$ 500.00	\$ 11,500.00
704	4011	PORTABLE CHANGEABLE MESSAGE SIGN	EA	2	\$ 4,500.00	\$ 9,000.00
706	500	AGGREGATE LABORATORY	EA	1	\$ 11,428.00	\$ 11,428.00
708	1540	INLET PROTECTION-SPECIAL	EA	73	\$ 161.00	\$ 11,753.00
708	1541	REMOVE INLET PROTECTION-SPECIAL	EA	73	\$ 43.25	\$ 3,157.25
709	100	GEOSYNTHETIC MATERIAL TYPE G	SY	14,689.00	\$ 2.50	\$ 36,722.50
709	151	GEOSYNTHETIC MATERIAL TYPE R1	SY	187	\$ 2.65	\$ 495.55
714	9100	CASTING CURB INLET	EA	1	\$ 500.00	\$ 500.00
714	9680	PLUG PIPE-ALL TYPES & SIZES	EA	9	\$ 2,500.00	\$ 22,500.00
714	9720	UNDERDRAIN PIPE PVC PERFORATED 4IN	LF	300	\$ 50.00	\$ 15,000.00
720	125	ALIGNMENT MONUMENTS	EA	15	\$ 292.42	\$ 4,386.30
720	130	IRON PIN R/W MONUMENTS	EA	2	\$ 75.00	\$ 150.00
722	100	MANHOLE 48IN	EA	8	\$ 1,800.00	\$ 14,400.00
722	110	MANHOLE 60IN	EA	5	\$ 3,350.00	\$ 16,750.00
722	120	MANHOLE 72IN	EA	3	\$ 4,500.00	\$ 13,500.00
722	130	MANHOLE 84IN	EA	2	\$ 7,500.00	\$ 15,000.00
722	140	MANHOLE 96IN	EA	1	\$ 5,000.00	\$ 5,000.00
722	1100	MANHOLE RISER 48IN	LF	36.18	\$ 206.55	\$ 7,472.98
722	1110	MANHOLE RISER 60IN	LF	35.12	\$ 363.60	\$ 12,769.63
722	1120	MANHOLE RISER 72IN	LF	16.55	\$ 480.00	\$ 7,944.00
722	1130	MANHOLE RISER 84IN	LF	29.3	\$ 579.00	\$ 16,964.70
722	1140	MANHOLE RISER 96IN	LF	5.76	\$ 680.00	\$ 3,916.80
722	3460	CASTING INLET-TYPE 2	EA	5	\$ 950.00	\$ 4,750.00
722	3495	MODIFY INLET	EA	2	\$ 500.00	\$ 1,000.00
722	3510	INLET-TYPE 2	EA	23	\$ 2,400.00	\$ 55,200.00
722	3520	INLET-TYPE 2 DOUBLE	EA	22	\$ 3,800.00	\$ 83,600.00
722	3701	INLET SPECIAL-TYPE 2 48IN	EA	2	\$ 2,625.00	\$ 5,250.00
722	3761	INLET SPECIAL-TYPE 2 60IN	EA	3	\$ 4,600.00	\$ 13,800.00
748	140	CURB & GUTTER-TYPE I	LF	5,700.00	\$ 20.00	\$ 114,000.00
748	141	CURB & GUTTER-TYPE 1 SPECIAL	LF	1,132.00	\$ 78.50	\$ 88,862.00
748	1280	VALLEY GUTTER SPECIAL	LF	292	\$ 55.20	\$ 16,118.40
750	30	PIGMENTED IMPRINTED CONCRETE	SY	5.81	\$ 108.52	\$ 630.50
750	101	SIDEWALK CONCRETE REINF	SY	2,609.00	\$ 35.00	\$ 91,315.00
750	1016	DRIVEWAY CONCRETE 6IN REINFORCED	SY	1,236.00	\$ 37.00	\$ 45,732.00

750	2115	DETECTABLE WARNING PANELS	SF	481	\$	48.75	\$	23,448.75
752	911	TEMPORARY SAFETY FENCE	LF	1,774.00	\$	1.95	\$	3,459.30
754	110	FLAT SHEET FOR SIGNS-TYPE XI REFL SHEETING	SF	480	\$	19.00	\$	9,120.00
754	112	FLAT SHEET FOR SIGNS-TYPE IV REFL SHEETING	SF	168	\$	18.00	\$	3,024.00
754	206	STEEL GALV POSTS-TELESCOPING PERFORATED TUBE	LF	928	\$	18.00	\$	16,704.00
754	592	RESET SIGN PANEL	EA	7	\$	75.00	\$	525.00
754	593	RESET SIGN SUPPORT	EA	4	\$	100.00	\$	400.00
762	122	PREFORMED PATTERNED PVMT MK-MESSAGE(GROOVED)	SF	210	\$	22.00	\$	4,620.00
762	420	SHORT TERM 4IN LINE-TYPE R	LF	2,105.00	\$	1.25	\$	2,631.25
762	424	SHORT TERM 8IN LINE-TYPE R	LF	150	\$	1.96	\$	294.00
762	430	SHORT TERM 4IN LINE-TYPE NR	LF	6,911.00	\$	0.25	\$	1,727.75
762	434	SHORT TERM 8IN LINE-TYPE NR	LF	500	\$	0.50	\$	250.00
762	442	SHORT TERM MESSAGE-TYPE NR	SF	536	\$	2.80	\$	1,500.80
762	1255	PREFORMED THERMO PLASTIC PVMT MK 6IN LINE	LF	106	\$	7.30	\$	773.80
762	1317	PREFORMED PATTERNED PVMT MK 16IN LINE-GROOVED	LF	123	\$	28.00	\$	3,444.00
762	1325	PREFORMED PATTERNED PVMT MK 24IN LINE-GROOVED	LF	452	\$	33.00	\$	14,916.00
762	1340	PREF PATT PVMT MK 4IN LINE CONTRAST-GROOVED	LF	11,103.00	\$	8.00	\$	88,824.00
762	1344	PREF PATT PVMT MK 7IN LINE CONTRAST-GROOVED	LF	209	\$	10.00	\$	2,090.00
772	2800	INTERIM TRAFFIC SIGNALS	EA	4	\$	55,531.00	\$	222,124.00
772	2904	REVISE TRAFFIC SIGNAL SYSTEM	EA	1	\$	25,000.00	\$	25,000.00
772	2935	REVISE FLASHING BEACON SYSTEM	EA	1	\$	15,000.00	\$	15,000.00
772	3125	REMOVE TRAFFIC SIGNAL SYSTEM	EA	1	\$	10,000.00	\$	10,000.00
772	9811	TRAFFIC SIGNAL SYSTEM - SITE 1	EA	1	\$	200,000.00	\$	200,000.00
772	9812	TRAFFIC SIGNAL SYSTEM - SITE 2	EA	1	\$	125,000.00	\$	125,000.00
920	90	LIFT STATION	EA	1	\$	525,000.00	\$	525,000.00
930	7000	NETTING	SF	720	\$	7.00	\$	5,040.00
930	8230	SHORING	EA	1	\$	30,000.00	\$	30,000.00
930	9612	SPALL REPAIR	SF	200	\$	100.00	\$	20,000.00
970	2005	AUTUMN BLAZE MAPLE	EA	19	\$	325.00	\$	6,175.00
\$								4,260,760.18 Base Total

Pipe Alternate A - Reinforced Concrete Pipe

714	105	PIPE CONC REINF 12IN CL II-STORM DRAIN	LF	12	\$	50.00	\$	600.00
714	210	PIPE CONC REINF 15IN CL III-STORM DRAIN	LF	1,869.00	\$	90.00	\$	168,210.00
714	315	PIPE CONC REINF 18IN CL III-STORM DRAIN	LF	622	\$	90.00	\$	55,980.00
714	620	PIPE CONC REINF 24IN CL III-STORM DRAIN	LF	310	\$	105.00	\$	32,550.00
714	710	PIPE CONC REINF 27IN CL III-STORM DRAIN	LF	17	\$	136.00	\$	2,312.00
714	825	PIPE CONC REINF 30IN CL III-STORM DRAIN	LF	147	\$	150.00	\$	22,050.00
714	910	PIPE CONC REINF 36IN CL III-STORM DRAIN	LF	78	\$	185.00	\$	14,430.00
714	1110	PIPE CONC REINF 48IN CL III-STORM DRAIN	LF	22	\$	195.00	\$	4,290.00
\$								300,422.00 Alt A Total

Pipe Alternate B - Pipe Conduit

714	4092	PIPE CONDUIT 12IN-STORM DRAIN	LF	12	\$	47.00	\$	564.00
714	4097	PIPE CONDUIT 15IN-STORM DRAIN	LF	1,869.00	\$	85.00	\$	158,865.00
714	4101	PIPE CONDUIT 18IN-STORM DRAIN	LF	622	\$	74.50	\$	46,339.00
714	4107	PIPE CONDUIT 24IN-STORM DRAIN	LF	310	\$	102.50	\$	31,775.00
714	4109	PIPE CONDUIT 27IN-STORM DRAIN	LF	17	\$	90.00	\$	1,530.00
714	4112	PIPE CONDUIT 30IN-STORM DRAIN	LF	147	\$	85.00	\$	12,495.00
714	4117	PIPE CONDUIT 36IN-STORM DRAIN	LF	78	\$	102.50	\$	7,995.00
714	4126	PIPE CONDUIT 48IN-STORM DRAIN	LF	22	\$	140.00	\$	3,080.00
\$								262,643.00 Alt B Total

Water and Sanitary Sewer (Non-Federal Aid Eligible)

Totals

103	100	CONTRACT BOND	L SUM	0.3	\$	32,900.00	\$	9,870.00
202	174	REMOVAL OF PIPE ALL TYPES AND SIZES	LF	5,891.00	\$	14.65	\$	86,303.15
202	210	REMOVAL OF MANHOLES	EA	10	\$	1,034.00	\$	10,340.00
702	100	MOBILIZATION	L SUM	0.3	\$	364,110.00	\$	109,233.00
722	100	MANHOLE 48IN	EA	11	\$	1,800.00	\$	19,800.00
722	300	MANHOLE SANITARY	EA	16	\$	4,500.00	\$	72,000.00
724	270	REMOVE GATE VALVE & BOX	EA	29	\$	300.00	\$	8,700.00
724	300	GATE VALVE & BOX 6IN	EA	15	\$	2,000.00	\$	30,000.00
724	310	GATE VALVE & BOX 8IN	EA	13	\$	2,500.00	\$	32,500.00
724	315	GATE VALVE & BOX 10IN	EA	2	\$	3,500.00	\$	7,000.00
724	317	GATE VALVE & BOX 16IN	EA	3	\$	4,500.00	\$	13,500.00
724	324	GATE VALVE & BOX 24IN	EA	11	\$	6,000.00	\$	66,000.00
724	410	HYDRANT-INSTALL 5IN	EA	8	\$	5,000.00	\$	40,000.00
724	430	REMOVE HYDRANT	EA	8	\$	300.00	\$	2,400.00
724	611	WATER SERVICE LINE 1IN	LF	1,758.10	\$	250.00	\$	439,525.00
724	670	TEMPORARY WATER SERVICE	L SUM	1	\$	20,000.00	\$	20,000.00
724	810	WATERMAIN 6IN PVC	LF	414	\$	28.00	\$	11,592.00
724	830	WATERMAIN 8IN PVC	LF	2,965.10	\$	32.00	\$	94,883.20
724	840	WATERMAIN 10IN PVC	LF	77.1	\$	40.00	\$	3,084.00
724	852	WATERMAIN 16IN PVC	LF	313.7	\$	50.00	\$	15,685.00
724	870	24IN WATERMAIN	LF	1,696.00	\$	75.00	\$	127,200.00
724	905	CURB STOP & BOX 1IN	EA	62	\$	500.00	\$	31,000.00
724	1117	12IN SANITARY SEWER PIPE	LF	3,063.70	\$	60.00	\$	183,822.00
724	1120	6IN SEWER SERVICE PIPE	LF	968.6	\$	28.00	\$	27,120.80

724	6031	ABANDON WATER MAIN/SERVICE LINE	LF	4,998.90	\$ 5.00	\$ 24,994.50
724	6101	BORE & PUSH 1IN WATER SERVICE	LF	175.8	\$ 45.00	\$ 7,911.00
910	575	PIPE SADDLE	LSUM	1	\$ 5,400.00	\$ 5,400.00
						\$ 1,499,863.65

Grand Total - Base Bid, Alt A and Water & Sewer \$ 6,061,045.83
 Grand Total - Base Bid, Alt B and Water & Sewer \$ 6,023,266.83

CITY OF FARGO
ENGINEERING DEPARTMENT

LOCATION & COMPRISING

PC CONCRETE PAVEMENT, STORM SEWER, WATERMAIN, SANITARY SEWER,
LIFT STATION, SIDEWALK, TRAFFIC SIGNALS & INCIDENTALS

IMPROVEMENT DISTRICT NO. BR-18-B

LOCATION:

On 10th Street North from 12th Avenue North to 4th Avenue North.

COMPRISING:

Lots 1 through 12, Block 1.
All in College Addition.

Lots 1 through 11, Block 4.
Lots 1 through 12, Block A.
Lots 1 through 10, Block B.
Lots C and D, Block B.
All in Replat of Kaufman's Subdivision.

Lots 1 through 16, Block 2.
Lots 1 through 8, Block 3.
All in Montplaisir's Subdivision.

Lots 1 and 2, Block 1.
All in Rhett's Row Addition.

Lots C and D, Block 5.
Lots A through O, Block 6.
Lots 1 through 24, Block 7.
Lots 13 through 24, Block 11.
Lots A through M, Block 12.
Lots A through K, Block 13.
Lots B through D, Block 14.
Lot B, Block 15.
All in Chapin's Addition.

Lots 1 through 6, Block 3.
Lots A through J, Block 3.
Lots 1 through 18, Block 4.
Lots 1 through 6, Block 5.
Lots A through J, Block 5.
Lots 4 through 6, Block 6.
Lots A and H through K, Block 6.
All in Harwood's Addition.

Location and Comprising
Improvement District No. BR-18-B
Page 2

Lots 1 through 11, Block 11.
Lots 1 through 11, Block 12.
Lots 1 through 10, Block 17.
Lots 1 through 10, Block 18.
All in Harwood's 2nd Addition.

Lots 4 through 10, Block 9.
Lots 1 through 14, Block 10.
Lots 1 through 10, Block 19.
Lots 4 through 8, Block 20.
All in Harwood's 3rd Addition.

Lots 1 through 5, Block 14.
Lots 1 through 6, Block 15.
Lots 1 through 6, Block 17.
Lots 1 through 9, Block 18.
Lots 5 through 9, Block 19.
Lots 1 through 12, Block 30.
Lots 1 through 6, Block 31.
Lots 1 through 6, Block 32.
Lots 7 through 12, Block 35.
All in Robert's 2nd Addition.

Lots 1 and 2, Block 1.
All in Fargo Park District North Maintenance Addition.

Lot 1, Block 1.
All in Christianson Addition.

All the foregoing is located in the City of Fargo, Cass County, North Dakota.

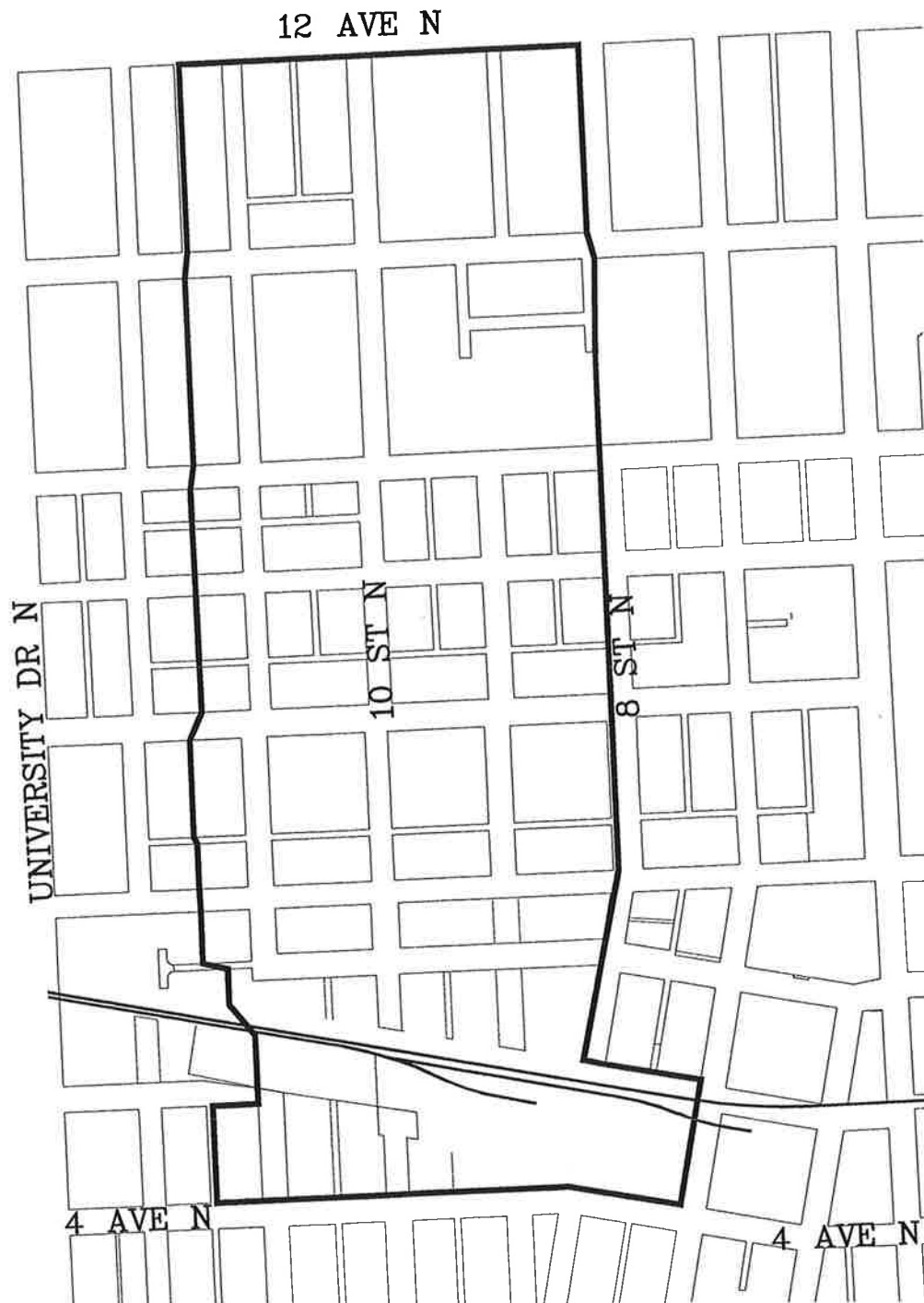

**CITY OF FARGO
ENGINEERING DEPARTMENT**

LOCATION & ASSESSMENT AREA

**PC CONCRETE PAVEMENT, STORM SEWER, WATERMAIN,
SANITARY SEWER, LIFT STATION, SIDEWALK,
TRAFFIC SIGNALS & INCIDENTALS**

IMPROVEMENT DISTRICT NO. BR-18-B

COVER SHEET
CITY OF FARGO PROJECTS

(35-2)

This sheet must be completed and turned in with all City of Fargo projects. NO items will be accepted by either the City Commission Office or the City Auditor's Office without this cover sheet attached and properly filled out.

Exact, full name of Improvement District as it will appear in the Contract:

PC CONCRETE PAVEMENT, STORM SEWER, SANITARY SEWER, PEDESTRIAN BOX
CULVERT, LIFT STATION, TRAFFIC SIGNALS, STREET LIGHTING, SIDEWALK &
INCIDENTALS

Improvement District No. PR-17-B

Call For Bids October 23, 2017

Advertise Dates October 30 & November 6, 2017

Bid Opening Date (NDDOT) November 17, 2017

Substantial Completion Date September 1, 2018

Final Completion Date October 1, 2018

N/A PWPEC Report (Part of 2017 CIP)

X Engineer's Report (Attach Copy)

N/A Direct City Auditor to Advertise for Bids (to be bid by NDDOT)

N/A Bid Quantities (Attach Copy for Auditor's Office Only)

X Notice to Property Owners (Dan Eberhardt)

Project Engineer Jeremy Gorden

Phone No. 241-1545

The items listed above are for use on all City projects. The additional items listed below are to be checked only when all or part of a project is to be special assessed:

X Create District (Attach Copy of Legal Description)

X Order Plans & Specifications

X Approve Plans & Specifications

X Adopt Resolution of Necessity

N/A Approve Escrow Agreement (Attach Copy for Commission Office Only)

X Assessment Map (Attach Copy for Auditor's Office Only)

ENGINEER'S REPORT

PC CONCRETE PAVEMENT, STORM SEWER, SANITARY SEWER, PEDESTRIAN BOX
CULVERT, LIFT STATION, TRAFFIC SIGNALS, STREET LIGHTING, SIDEWALK &
INCIDENTALS

IMPROVEMENT DISTRICT NO. PR-17-B

Nature and Scope

This project is for the pavement reconstruction on University Drive from 18th Avenue S to the north side of the I-94 bridge. It provides for the replacement of the sanitary sewer, installation of new storm sewer, a new pedestrian underpass under the westbound I-94 on-ramp (NW quadrant of the interchange), replacement of the traffic signals, new sidewalk and intersection reconfiguring on the east side of University at 21st Avenue S. University Drive will remain a 6-lane concrete roadway but will have a raised median just south of 18th Avenue S intersection. The sanitary sewer will be replaced a short stretch from 18th Avenue S to the north ramp of the I-94 interchange.

This project was approved by the Fargo City Commission under the 2017 Capital Improvements Program (CIP) and the project's federally mandated environmental document was approved by the Fargo City Commission last April.

Purpose

University Drive is functionally classified as a major arterial roadway and is part of the NDDOT Regional Highway System. It is the backbone of Fargo's roadway network. The purpose of this project is to address pavement conditions, driveway access control, and pedestrian and bicyclist safety.

Feasibility

The estimated construction cost is approximately \$5,318,361 (\$4,748,428 Fed/\$280,910 State/\$544,395 Local). Funding for the project will consist of Federal Highway Funds from both the Interstate Maintenance Funds and Regional Highway System, NDDOT State Funds, Sewer Utility Funds and Special Assessment Funds (Local). The project's cost breakout is as follows:

Interchange Portion of Project

Federal and State Funded Interchange Construction Cost	\$ 2,553,735
Plus Fees:	
10% NDDOT Engineering:	\$ 255,373
Total Estimated Federal & State Funded Interchange Cost	\$ 2,809,108

Street Reconstruction Cost

Assessed Street Reconstruction Construction Cost	\$ 301,773
Plus Fees:	
4% Engineering:	\$ 12,070
6% Administration:	\$ 18,106
7% Miscellaneous:	\$ 21,124
4% Interest:	\$ 12,070
Right-of-Way	\$ 100,000
Utility Relocations	\$ 100,000

Consulting Engineering Fee – Preliminary and Final Design	\$ 400,000
Consulting Engineering Fee – Construction Services	\$ 100,000
Total Estimated Assessed Street Reconstruction Cost	\$ 1,065,145

Federal Funded Street Reconstruction Construction Cost	\$ 2,469,055
Plus Fees:	
10% NDDOT Engineering:	\$ 246,905
Total Estimated Federal Funded Street Reconstruction Cost:	\$ 2,715,961

Total Estimated Street Reconstruction Cost: \$ 3,781,106

Sanitary Sewer Cost

Assessed Sanitary Sewer Construction Cost	\$ 10,615
Plus Fees:	
4% Engineering:	\$ 424
6% Administration:	\$ 636
7% Miscellaneous:	\$ 743
4% Interest:	\$ 424
Consulting Engineering Fee – Preliminary and Final Design	\$ 3,750

Total Estimated Sanitary Sewer Assessed Cost \$ 16,594

City Funded Sanitary Sewer Construction Cost	\$ 10,615
Plus Fees:	
4% Engineering:	\$ 424
7% Miscellaneous:	\$ 743
4% Interest	\$ 424
Consulting Engineering Fee – Preliminary and Final Design	\$ 3,750

Total Estimated City Funded Sanitary Sewer Cost \$ 15,956

Total Estimated Sanitary Sewer Cost: \$ 32,550

Estimated Project Cost \$ 6,622,764

Project Funding Summary

Interstate Maintenance Funds	\$ 2,528,198
NDDOT State Funds	\$ 280,910
NDDOT Regional Highway System Funds (Federal)	\$ 2,715,961
Special Assessments – Street Reconstruction	\$ 1,065,145
Special Assessments – Sanitary Sewer	\$ 16,594
Sewer Utility Funds (City)	\$ 15,956

Costs will be special assessed according to City policy.

We believe this project to be cost effective.

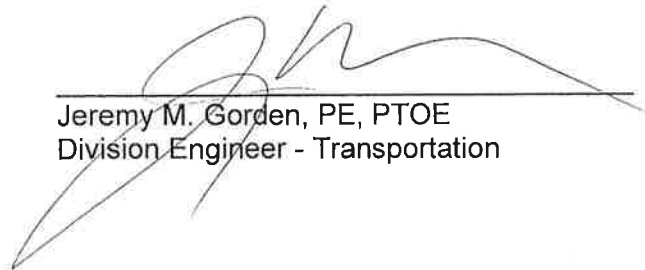
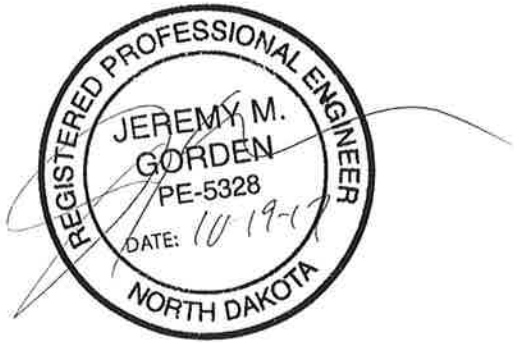

Jeremy M. Gorden, PE, PTOE
Division Engineer - Transportation

October 2017

Engineer's Opinion of Cost
ND DOT Project Nos. NHU-8-081(039)924 & IM-8-094(090)351
University Drive - 18th Avenue S to 21st Avenue S
City of Fargo Improvement District No. PR-17-B
#####

PCN 21169 & 21400

SPEC	CODE	ITEM DESCRIPTION	UNIT COST	UNIT	IM-8-094(090)351		NHU-8-081(039)924			TOTAL
					QUANTITY	SUBTOTAL	ELIGIBLE QUANTITY	ELIGIBLE SUBTOTAL	NONELIGIBLE QUANTITY	
103	0100	CONTRACT BOND	\$ 40,000.00	LSUM	0.5	\$ 20,000.00	0.5	\$ 20,000.00	\$ -	\$ 40,000.00
201	0330	CLEARING & GRUBBING	\$ 10,000.00	LSUM	0.5	\$ 5,000.00	0.5	\$ 5,000.00	\$ -	\$ 10,000.00
202	0114	REMOVAL OF CONCRETE PAVEMENT	\$ 20.00	SY	207	\$ 4,140.00	1,332	\$ 26,640.00	\$ -	\$ 30,780.00
202	0130	REMOVAL OF CURB & GUTTER	\$ 6.00	LF	998	\$ 5,988.00	6,171	\$ 37,026.00	\$ -	\$ 43,014.00
202	0136	REMOVAL OF PAVEMENT	\$ 9.00	TON	4,552	\$ 40,968.00	19,416	\$ 174,744.00	\$ -	\$ 215,712.00
202	0174	REMOVAL OF PIPE ALL TYPES AND SIZES	\$ 12.00	LF	155	\$ 1,860.00	1,927	\$ 23,124.00	\$ -	\$ 24,984.00
202	0210	REMOVAL OF MANHOLES	\$ 650.00	EA	3	\$ 1,950.00	6	\$ 3,900.00	\$ -	\$ 3,900.00
202	0235	REMOVAL OF CATCH BASINS	\$ 450.00	EA	3	\$ 1,350.00	10	\$ 4,500.00	\$ -	\$ 5,850.00
202	0290	REMOVAL OF SLOPE PROTECTION	\$ 20.00	SY	597	\$ 11,940.00	597	\$ 11,940.00	\$ -	\$ 11,940.00
202	0293	REMOVE RETAINING WALL	\$ 5.00	LF	62	\$ 310.00	62	\$ 310.00	\$ -	\$ 310.00
202	0312	REMOVE EXISTING FENCE	\$ 1.00	LF	270	\$ 270.00	270	\$ 270.00	\$ -	\$ 270.00
203	0101	COMMON EXCAVATION-TYPE A	\$ 5.00	CY	2,048	\$ 10,240.00	951	\$ 4,755.00	\$ -	\$ 14,995.00
203	0109	TOPSOIL	\$ 3.00	CY	1,912	\$ 5,736.00	1,291	\$ 3,873.00	\$ -	\$ 9,609.00
203	0113	COMMON EXCAVATION-WASTE	\$ 6.00	CY	2,705	\$ 16,230.00	1	\$ 6.00	\$ -	\$ 16,230.00
210	0050	BOX CULVERT EXCAVATION	\$ 25,000.00	EA	1	\$ 25,000.00	1	\$ 25,000.00	\$ -	\$ 25,000.00
210	0210	FOUNDATION FILL	\$ 50.00	CY	1,415	\$ 70,750.00	1	\$ 50.00	\$ -	\$ 70,750.00
210	0405	FOUNDATION PREPARATION-BOX CULVERT	\$ 15,000.00	EA	1	\$ 15,000.00	1	\$ 15,000.00	\$ -	\$ 15,000.00
216	0100	WATER	\$ 25.00	M GAL	101	\$ 2,525.00	233	\$ 5,825.00	\$ -	\$ 8,350.00
251	0300	SEEDING CLASS III	\$ 350.00	ACRE	2.37	\$ 829.50	1.60	\$ 560.00	\$ -	\$ 1,389.50
251	2000	TEMPORARY COVER CROP	\$ 100.00	ACRE	2.37	\$ 237.00	1.60	\$ 160.00	\$ -	\$ 397.00
253	0201	HYDRAULIC MULCH	\$ 2,500.00	ACRE	2.37	\$ 5,925.00	1.60	\$ 4,000.00	\$ -	\$ 9,925.00
253	0301	BONDED FIBER MATRIX	\$ 6,000.00	ACRE	2.37	\$ 14,220.00	1.60	\$ 9,600.00	\$ -	\$ 23,820.00
258	0100	CONCRETE SLOPE PROTECTION	\$ 150.00	SY	14	\$ 2,100.00	210	\$ 31,500.00	\$ -	\$ 31,500.00
261	0112	FIBER ROLLS 12IN	\$ 2.00	LF	5,980	\$ 11,960.00	2,480	\$ 4,960.00	\$ -	\$ 16,920.00
261	0113	REMOVE FIBER ROLLS 12IN	\$ 0.50	LF	2,990	\$ 1,495.00	1,240	\$ 620.00	\$ -	\$ 2,115.00
302	0100	SALVAGED BASE COURSE	\$ 10.00	TON	4,078	\$ 40,780.00	11,015	\$ 110,150.00	\$ -	\$ 150,930.00
430	0500	COMMERCIAL GRADE HOT MIX ASPHALT	\$ 125.00	TON	473	\$ 59,125.00	468	\$ 58,500.00	\$ -	\$ 117,625.00
550	0815	11IN NON-REINF CONCRETE PVMT CL AE-DOWELED	\$ 75.00	SY	3,205	\$ 240,375.00	11,581	\$ 868,575.00	\$ -	\$ 1,108,950.00
602	1131	CLASS AE-3 CONCRETE-BOX CULVERT	\$ 1,500.00	CY	114.3	\$ 171,450.00	1	\$ 1,500.00	\$ -	\$ 171,450.00
612	0114	REINFORCING STEEL-GRADE 60-BOX CULVERT	\$ 3.00	LBS	21,129	\$ 63,387.00	1	\$ 3.00	\$ -	\$ 63,387.00
624	0123	PEDESTRIAN RAILING	\$ 175.00	LF	270	\$ 47,250.00	270	\$ 47,250.00	\$ -	\$ 47,250.00
702	0100	MOBILIZATION	\$ 500,000.00	LSUM	0.5	\$ 250,000.00	0.5	\$ 250,000.00	\$ -	\$ 500,000.00
704	0100	FLAGGING	\$ 35.00	MHR	400.0	\$ 14,000.00	400.0	\$ 14,000.00	\$ -	\$ 28,000.00
704	1000	TRAFFIC CONTROL SIGNS	\$ 2.00	UNIT	4,487	\$ 8,974.00	4,487	\$ 8,974.00	\$ -	\$ 8,974.00
704	1037	ATTENUATION DEVICE-TYPE B-35	\$ 2,000.00	EA	1	\$ 2,000.00	2	\$ 4,000.00	\$ -	\$ 6,000.00
704	1052	TYPE III BARRICADE	\$ 120.00	EA	36	\$ 4,320.00	36	\$ 4,320.00	\$ -	\$ 4,320.00
704	1060	DELINEATOR DRUMS	\$ 25.00	EA	162	\$ 4,050.00	162	\$ 4,050.00	\$ -	\$ 4,050.00
704	1067	TUBULAR MARKERS	\$ 10.00	EA	198	\$ 1,980.00	198	\$ 1,980.00	\$ -	\$ 1,980.00
704	1070	DELINEATOR	\$ 50.00	EA	40	\$ 2,000.00	40	\$ 2,000.00	\$ -	\$ 2,000.00
704	1072	FLEXIBLE DELINEATORS	\$ 65.00	EA	88	\$ 5,720.00	88	\$ 5,720.00	\$ -	\$ 5,720.00
704	1080	STACKABLE VERTICAL PANELS	\$ 30.00	EA	30	\$ 900.00	30	\$ 900.00	\$ -	\$ 900.00
704	1087	SEQUENCING ARROW PANEL-TYPE C	\$ 1,400.00	EA	2	\$ 2,800.00	2	\$ 2,800.00	\$ -	\$ 2,800.00
704	1500	OBTLERATION OF PVMT MK	\$ 2.50	SF	1,364	\$ 3,410.00	1,364	\$ 3,410.00	\$ -	\$ 3,410.00
704	3510	PRECAST CONCRETE MED BARRIER-STATE FURNISHED	\$ 320.00	EA	20	\$ 6,400.00	2	\$ 640.00	\$ -	\$ 6,400.00
704	4011	PORTABLE CHANGEABLE MESSAGE SIGN	\$ 12,500.00	EA	2	\$ 25,000.00	2	\$ 25,000.00	\$ -	\$ 25,000.00
706	0400	FIELD OFFICE	\$ 12,500.00	EA	0.5	\$ 6,250.00	0.5	\$ 6,250.00	\$ -	\$ 12,500.00
706	0500	AGGREGATE LABORATORY	\$ 10,000.00	EA	0.5	\$ 5,000.00	0.5	\$ 5,000.00	\$ -	\$ 10,000.00
706	0600	CONTRACTOR'S LABORATORY	\$ 5,000.00	EA	0.5	\$ 2,500.00	0.5	\$ 2,500.00	\$ -	\$ 5,000.00
708	1540	INLET PROTECTION-SPECIAL	\$ 150.00	EA	27	\$ 4,050.00	27	\$ 4,050.00	\$ -	\$ 4,050.00
708	1541	REMOVE INLET PROTECTION-SPECIAL	\$ 35.00	EA	27	\$ 945.00	27	\$ 945.00	\$ -	\$ 945.00
709	0100	GEOSYNTHETIC MATERIAL TYPE G	\$ 2.50	SY	161	\$ 402.50	161	\$ 402.50	\$ -	\$ 402.50
709	0151	GEOSYNTHETIC MATERIAL TYPE R1	\$ 2.00	SY	4,394	\$ 8,788.00	15,516	\$ 31,032.00	\$ -	\$ 39,820.00
710	0410	REMOVAL OF TEMP CONNECTION	\$ 5,000.00	EA	1	\$ 5,000.00	1	\$ 5,000.00	\$ -	\$ 10,000.00
714	0120	PIPE C R 12IN CL III-STORM DRAIN 45DEG BEND	\$ 1,000.00	EA	1	\$ 1,000.00	1	\$ 1,000.00	\$ -	\$ 1,000.00
714	4105	PIPE CONDUIT 24IN	\$ 150.00	LF	56	\$ 8,400.00	56	\$ 8,400.00	\$ -	\$ 8,400.00
714	7040	SANITARY SEWER SERVICE CONNECTION	\$ 500.00	EA	2	\$ 1,000.00	2	\$ 1,000.00	\$ -	\$ 1,000.00
722	0100	MANHOLE 48IN	\$ 2,500.00	EA	4	\$ 10,000.00	4	\$ 10,000.00	\$ -	\$ 11,000.00
722	0110	MANHOLE 60IN	\$ 2,750.00	EA	2	\$ 5,500.00	2	\$ 5,500.00	\$ -	\$ 11,000.00
722	1100	MANHOLE RISER 48IN	\$ 200.00	LF	22.54	\$ 4,508.00	22.54	\$ 4,508.00	\$ -	\$ 4,508.00
722	1110	MANHOLE RISER 60IN	\$ 300.00	LF	20.03	\$ 6,009.00	20.03	\$ 6,009.00	\$ -	\$ 6,009.00
722	3510	INLET-TYPE 2	\$ 2,750.00	EA	2	\$ 5,500.00	7	\$ 19,250.00	\$ -	\$ 24,750.00
722	3701	INLET SPECIAL-TYPE 2 48IN	\$ 3,700.00	EA	3	\$ 11,100.00	3	\$ 11,100.00	\$ -	\$ 11,100.00
722	3730	INLET SPECIAL CATCH BASIN 9IN BEEHIVE 48IN	\$ 3,500.00	EA	6	\$ 21,000.00	6	\$ 21,000.00	\$ -	\$ 21,000.00
722	3910	INLET SLOTTED DRAIN 15IN	\$ 300.00	LF	20	\$ 6,000.00	20	\$ 6,000.00	\$ -	\$ 6,000.00
722	4020	INLET CATCH BASIN 9IN BEEHIVE	\$ 1,500.00	EA	3	\$ 4,500.00	3	\$ 4,500.00	\$ -	\$ 4,500.00
722	6140	ADJUST GATE VALVE BOX	\$ 500.00	EA	3	\$ 1,500.00	3	\$ 1,500.00	\$ -	\$ 1,500.00
724	0425	RESET HYDRANT	\$ 2,000.00	EA	2	\$ 4,000.00	2	\$ 4,000.00	\$ -	\$ 4,000.00
724	0810	WATERMAIN 6IN PVC	\$ 130.00	LF	6	\$ 780.00	6	\$ 780.00	\$ -	\$ 780.00
724	1110	BIN SANITARY SEWER PIPE	\$ 30.00	LF	541	\$ 16,230.00	541	\$ 16,230.00	\$ -	\$ 16,230.00
748	0140	CURB & GUTTER-TYPE I	\$ 20.00	LF	1,339	\$ 26,780.00	6,211	\$ 124,220.00	\$ -	\$ 151,000.00
750	0030	PIGMENTED IMPRINTED CONCRETE	\$ 115.00	SY	333	\$ 38,295.00	333	\$ 38,295.00	\$ -	\$ 38,295.00
750	0100	SIDEWALK CONCRETE	\$ 40.00	SY	1,986	\$ 79,440.00	1,986	\$ 79,440.00	\$ -	\$ 79,440.00
750	0150	SIDEWALK TRENCH DRAIN	\$ 2,500.00	EA	3	\$ 7,500.00	3	\$ 7,500.00	\$ -	\$ 7,500.00
750	0200	CONCRETE MEDIAN PAVING	\$ 60.00	SY	233	\$ 13,980.00	1,245	\$ 74,700.00	\$ -	\$ 88,680.00
750	0210	CONCRETE MEDIAN NOSE PAVING	\$ 150.00	SY	11	\$ 1,650.00	26	\$ 3,900.00	\$ -	\$ 5,550.00
750	1000	DRIVEWAY CONCRETE	\$ 75.00	SY	291	\$ 21,825.00	291	\$ 21,825.00	\$ -	\$ 21,825.00
750	2115	DETECTABLE WARNING PANELS	\$ 45.00	SF	190	\$ 8,550.00	190	\$ 8,550.00	\$ -	\$ 8,550.00
752	0911	TEMPORARY SAFETY FENCE	\$ 5.00	LF	317	\$ 1,585.00	317	\$ 1,585.00	\$ -	\$ 1,585.00
754	0110	FLAT SHEET FOR SIGNS-TYPE XI REFL SHEETING	\$ 20.00	SF	331	\$ 6,620.00	167	\$ 3,340.00	\$ -	\$ 9,960.00
754	0112	FLAT SHEET FOR SIGNS-TYPE IV REFL SHEETING	\$ 20.00	SF	38	\$ 760.00	71	\$ 1,420.00	\$ -	\$ 2,180.00
754	0193	FLEXIBLE DELINEATORS-TYPE D	\$ 90.00	EA	3	\$ 270.00	8	\$ 720.00	\$ -	\$ 990.00
754	0198	DIAMOND GRADE DELINEATORS-TYPE D	\$ 110.00	EA	18	\$ 1,980.00	18	\$ 1,980.00	\$ -	\$ 1,980.00
754	0206	STEEL GALV POSTS-TELESCOPING PERFORATED TUBE	\$ 20.00	LF	337	\$ 6,740.00	337	\$ 6,740.00	\$ -	\$ 6,740.00
754	0210	GALV STEEL POSTS-STANDARD PIPE	\$ 70.00	LF	171	\$ 11,970.00	171	\$ 11,970.00	\$ -	\$ 11,970.00
754	0530	PANEL FOR SIGNS-TYPE XI REFLECTIVE SHEETING	\$ 25.00	SF	693	\$ 17,325.00	693	\$ 17,325.00	\$ -	\$ 17,325.00
754	0563	REFERENCE MARKER-TYPE C	\$ 250.00	EA	1	\$ 250.00	1	\$ 250.00	\$ -	\$ 250.00
754	0592	RESET SIGN PANEL	\$ 100.00	EA	2	\$ 200.00	2	\$ 200.00	\$ -	\$ 200.00
754	1100	CLASS AE CONCRETE-SIGN FOUNDATIONS	\$ 2,000.00	CY	86.0	\$ 172,000.00	86.0	\$ 172,000.00	\$ -	\$ 172,000.00
754	1104	REMOVE SIGN FOUNDATION	\$ 550.00	EA	5	\$ 2,750.00	5	\$ 2,750.00	\$ -	\$ 2,750.00
754	1325	OVERHEAD SIGN STR 40FT CANTILEVER	\$ 70,000.00	EA	1	\$ 70,000.00	1	\$ 70,000.00	\$ -	\$ 70,000.00
754	1457	OVERHEAD SIGN STR 97FT TRUSS	\$ 135,000.00	EA	1	\$ 135,000.00	1	\$ 135,000.00	\$ -	\$ 135,000.00
754	1590	REMOVE OVERHEAD SIGN STR TRUSS	\$ 15,000.00	EA	2	\$ 30,000.00	2	\$ 30,000.00	\$ -	\$ 30,000.00
762	0122	PREFORMED PATTERNED PVMT MK - MESSAGE (GROOVED)	\$ 26.00	SF	127	\$ 3,302.00	245	\$ 6,370.00	\$ -	\$ 9,672.00
762	0420	SHORT TERM 4IN LINE-TYPE R	\$ 1.30	LF	35,374	\$ 45,986.20	35,374	\$ 45,986.20	\$ -	\$ 45,986.20
762	0424	SHORT TERM 8IN LINE-TYPE R	\$ 2.50	LF	1,253	\$ 3,132.50	1,253	\$ 3,132.50	\$ -	\$ 3,132.50

762	0436	SHORT TERM 24IN LINE-TYPE R	\$ 5.00	LF		\$ -	393	\$ 1,965.00		\$ -	\$ 1,965.00	
762	0440	SHORT TERM MESSAGE-TYPE R	\$ 30.00	SF		\$ -	300	\$ 9,000.00		\$ -	\$ 9,000.00	
762	1305	PREFORMED PATTERNED PVMT MK 4IN LINE-GROOVED	\$ 3.50	LF	586	\$ 2,051.00	1,259	\$ 4,406.50		\$ -	\$ 6,457.50	
762	1307	PREFORMED PATTERNED PVMT MK 6IN LINE-GROOVED	\$ 9.00	LF		\$ -	518	\$ 4,662.00		\$ -	\$ 4,662.00	
762	1309	PREFORMED PATTERNED PVMT MK 8IN LINE-GROOVED	\$ 9.50	LF	957	\$ 9,091.50	1,865	\$ 17,717.50		\$ -	\$ 26,809.00	
762	1325	PREFORMED PATTERNED PVMT MK 24IN LINE-GROOVED	\$ 30.00	LF	48	\$ 1,440.00	198	\$ 5,940.00		\$ -	\$ 7,380.00	
762	1344	PREF PATT PVMT MK 7IN LINE CONTRAST-GROOVED	\$ 12.00	LF		\$ -	1,038	\$ 12,456.00		\$ -	\$ 12,456.00	
770	0001	LIGHTING SYSTEM	\$ 13,000.00	EA		\$ -	1	\$ 13,000.00		\$ -	\$ 13,000.00	
770	0003	LIGHTING SYSTEM A	\$ 60,500.00	EA		\$ -	1	\$ 60,500.00		\$ -	\$ 60,500.00	
770	0004	LIGHTING SYSTEM B	\$ 6,000.00	EA		\$ -	1	\$ 6,000.00		\$ -	\$ 6,000.00	
770	0005	LIGHTING SYSTEM C	\$ 5,500.00	EA	1	\$ 5,500.00		\$ -		\$ -	\$ 5,500.00	
770	4560	REMOVE LIGHT STANDARD	\$ 500.00	EA		\$ -	13	\$ 6,500.00		\$ -	\$ 6,500.00	
770	4570	REMOVE STREET LIGHT LUMINARE	\$ 150.00	EA		\$ -	3	\$ 450.00		\$ -	\$ 450.00	
770	4590	REMOVE FEED POINT	\$ 350.00	EA		\$ -	1	\$ 350.00		\$ -	\$ 350.00	
772	2800	INTERIM TRAFFIC SIGNALS	\$ 45,000.00	EA	2	\$ 90,000.00	1	\$ 45,000.00		\$ -	\$ 135,000.00	
772	9811	TRAFFIC SIGNALS SYSTEM - SITE 1	\$ 225,000.00	EA	1	\$ 225,000.00		\$ -		\$ -	\$ 225,000.00	
772	9812	TRAFFIC SIGNALS SYSTEM - SITE 2	\$ 250,000.00	EA	1	\$ 250,000.00		\$ -		\$ -	\$ 250,000.00	
772	9813	TRAFFIC SIGNALS SYSTEM - SITE 3	\$ 135,000.00	EA		\$ -	1	\$ 135,000.00		\$ -	\$ 135,000.00	
920	0090	LIFT STATION	\$ 230,000.00	EA	1	\$ 230,000.00		\$ -		\$ -	\$ 230,000.00	
930	9543	RETAINING WALL	\$ 50.00	SF		\$ -	93	\$ 4,650.00		\$ -	\$ 4,650.00	
						Subtotal	\$ 2,514,280.50	Subtotal	\$ 2,659,630.70	Subtotal	\$ 21,230.00	\$ 5,195,141.20

Option 1 - Storm Sewer Pipe

SPEC	CODE	ITEM DESCRIPTION	UNIT COST	UNIT	IM-8-094(090)351		NHU-8-081(039)924			TOTAL		
					QUANTITY	SUBTOTAL	ELIGIBLE QUANTITY	ELIGIBLE SUBTOTAL	NONELIGIBLE QUANTITY		NONELIGIBLE SUBTOTAL	
714	4092	PIPE CONDUIT 12IN-STORM DRAIN	\$ 80.00	LF		\$ -	12	\$ 960.00		\$ -	\$ 960.00	
714	4097	PIPE CONDUIT 15IN-STORM DRAIN	\$ 100.00	LF	637	\$ 63,700.00	277	\$ 27,700.00		\$ -	\$ 91,400.00	
714	4101	PIPE CONDUIT 18IN-STORM DRAIN	\$ 120.00	LF		\$ -	767	\$ 92,040.00		\$ -	\$ 92,040.00	
714	4107	PIPE CONDUIT 24IN-STORM DRAIN	\$ 150.00	LF		\$ -	313	\$ 46,950.00		\$ -	\$ 46,950.00	
714	4112	PIPE CONDUIT 30IN-STORM DRAIN	\$ 160.00	LF		\$ 8,320.00		\$ -		\$ -	\$ 8,320.00	
						Subtotal	\$ 72,020.00	Subtotal	\$ 167,650.00	Subtotal	\$ -	\$ 239,670.00

Option 2 - Concrete Storm Sewer Pipe

SPEC	CODE	ITEM DESCRIPTION	UNIT COST	UNIT	IM-8-094(090)351		NHU-8-081(039)924			TOTAL		
					QUANTITY	SUBTOTAL	ELIGIBLE QUANTITY	ELIGIBLE SUBTOTAL	NONELIGIBLE QUANTITY		NONELIGIBLE SUBTOTAL	
714	0115	PIPE CONC REINF 12IN CL III-STORM DRAIN	\$ 50.00	LF		\$ -	12	\$ 600.00		\$ -	\$ 600.00	
714	0210	PIPE CONC REINF 15IN CL III-STORM DRAIN	\$ 55.00	LF	637	\$ 35,035.00	277	\$ 15,235.00		\$ -	\$ 50,270.00	
714	0315	PIPE CONC REINF 18IN CL III-STORM DRAIN	\$ 60.00	LF		\$ -	767	\$ 46,020.00		\$ -	\$ 46,020.00	
714	0620	PIPE CONC REINF 24IN CL III-STORM DRAIN	\$ 70.00	LF		\$ -	313	\$ 21,910.00		\$ -	\$ 21,910.00	
714	0825	PIPE CONC REINF 30IN CL III-STORM DRAIN	\$ 85.00	LF	52	\$ 4,420.00		\$ -		\$ -	\$ 4,420.00	
						Subtotal	\$ 39,455.00	Subtotal	\$ 83,765.00	Subtotal	\$ -	\$ 123,220.00

Total Base plus Option 2 \$ 2,553,735.50 \$ 2,743,395.70 \$ 5,318,361.20

CITY OF FARGO
ENGINEERING DEPARTMENT

LOCATION & COMPRISING

PC CONCRETE PAVEMENT, STORM SEWER, SANITARY SEWER,
PEDESTRIAN BOX CULVERT, LIFT STATION, TRAFFIC SIGNALS,
STREET LIGHTING, SIDEWALK & INCIDENTALS

IMPROVEMENT DISTRICT NO. PR-17-B

LOCATION:

On University Drive South from 18th Avenue South to 21st Avenue South.

COMPRISING:

Lots 1 through 20, Block 7.
Lots 1 through 24, Block 8.
Lots 1 through 23, Block 9.
Lots 1 through 24, Block 10.
Lots 2 through 13, Block 11.
Lots A through L, Block 11.
Block 12.
Lots 1 through 10, Block 13.
Lots 1 through 10, Block 14.
All in Bohnsack's 2nd Addition.

Block 15.
Lots 1 through 5, Block 16.
Lots 1 through 8, Block 17.
Lots 1 through 10, Block 18.
Lots 1 through 12, Block 19.
Lots 1 through 14, Block 20.
Lots 1 through 16, Block 21.
All in Bohnsack's 3rd Addition.

Lots 1 through 34, Block 1.
Lots 1 through 17, Block 2.
Lots 1 through 43, Block 3.
Lots 2 through 24, Block 4.
Block 5.
Block 6.
All in Harry A. Schnell Addition.

Lots 1, Block 1.
All in Lindenwood Park Addition.

Location and Comprising
Improvement District No. PR-17-B
Page 2

Lots 1, Block 1.
All in Nativity Addition.

All the foregoing is located in the City of Fargo, Cass County, North Dakota.

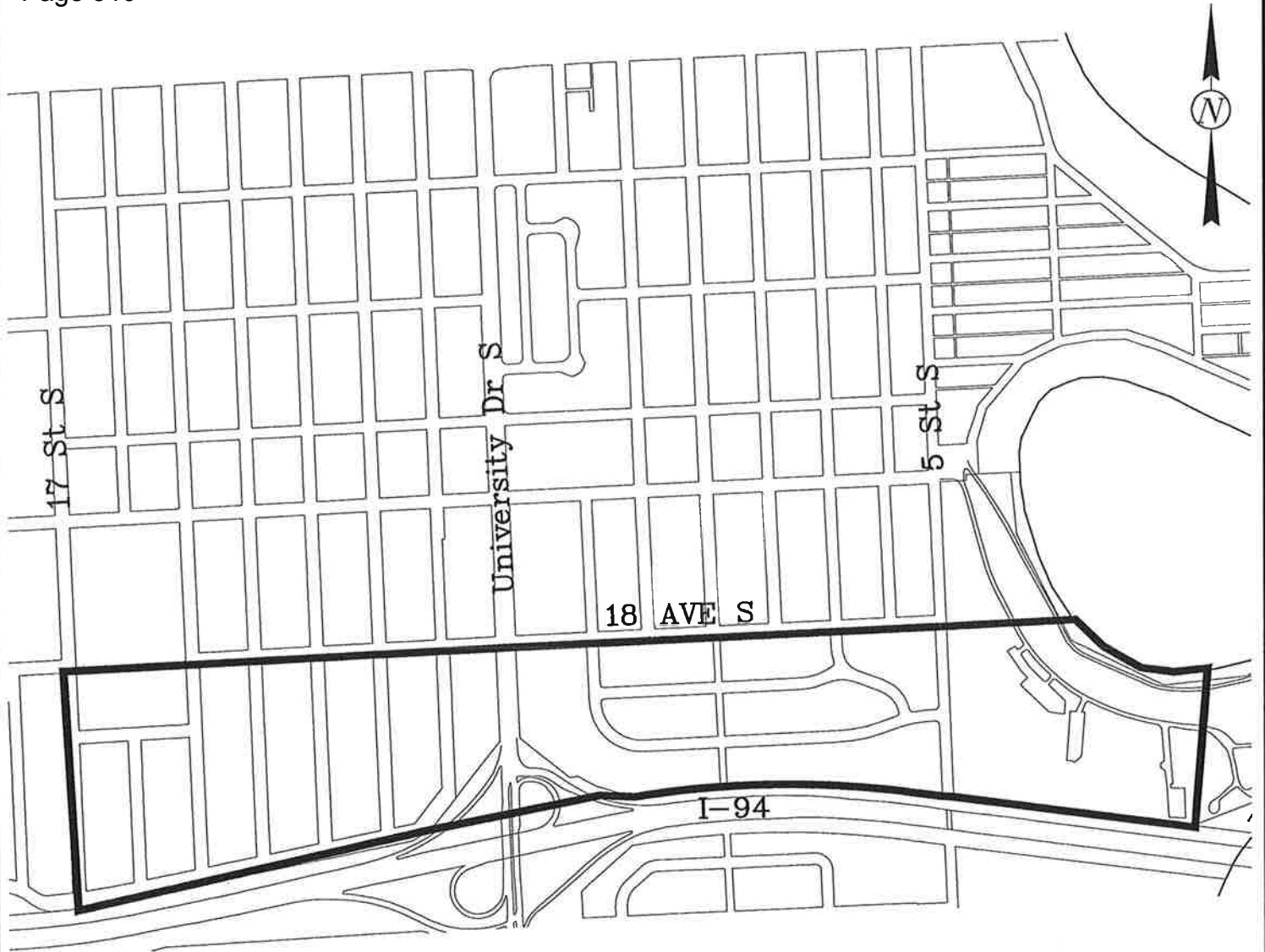

**CITY OF FARGO
ENGINEERING DEPARTMENT**

LOCATION & ASSESSMENT AREA

**PC CONCRETE PAVEMENT, STORM SEWER, SANITARY SEWER,
PEDESTRIAN BOX CULVERT, LIFT STATION, TRAFFIC SIGNALS,
STREET LIGHTING, SIDEWALK & INCIDENTALS**

IMPROVEMENT DISTRICT NO. PR-17-B