

FARGO CITY COMMISSION AGENDA  
Monday, October 8, 2018 - 5:00 p.m.

City Commission meetings are broadcast live on TV Fargo Channel 56 and online at [www.FargoND.gov/streaming](http://www.FargoND.gov/streaming). They are rebroadcast Mondays at 5:00 p.m., Thursdays at 7:00 p.m. and Saturdays at 8:00 a.m. They are also included in the video archive at [www.FargoND.gov/citycommission](http://www.FargoND.gov/citycommission).

- A. Pledge of Allegiance.
- B. Roll Call.
- C. Approve Order of Agenda.
- D. Minutes (Amendment of September 10, 2018 Regular Meeting; Approval of September 24, 2018 Regular Meeting).

**CONSENT AGENDA – APPROVE THE FOLLOWING:**

- 1. Waive requirement to receive and file an Ordinance one week prior to 1st reading and 1st reading of an Ordinance Amending Section 23-0211 of Article 23-02 of Chapter 23 of the Fargo Municipal Code Relating to the Electrical Code.
- 2. 1st reading of the following Ordinances:
  - a. Amending Section 8-1009 of Article 8-10 of Chapter 8 of the Fargo Municipal Code Relating to Parking Regulations.
  - b. Amending Sections 38-0101, 38-0103, 38-0105, 38-0106 & 38-0107, of Article 38-01 of Chapter 38 of the Fargo Municipal Code Relating to Street Lighting and Traffic Control Devices System.
- 3. 2nd reading and final adoption of the following Ordinances; 1st reading 8/24/18:
  - a. Amending Section 8-1425, of Article 8-14 of Chapter 8 of the Fargo Municipal Code Relating to Bicycles.
  - b. Amending Section 01-0305, of Article 01-03 of Chapter 01 of the Fargo Municipal Code Relating to General Provisions.
  - c. Enacting Article 3-23 of Chapter 3 of the Fargo Municipal Code Relating to Collection of Utilities and Services.
- 4. Agreement (Hoffman Glass Pile) with Dak Real Estate Holdings, Inc. for removal of glass pile.
- 5. Easement Release Agreement with Southeast Cass Water Resource District, State of North Dakota, Oak Grove Foundation Properties, LLC and Park Christian School, Inc.
- 6. Receive and file Summons in the matter of James Peter Sabo vs. City of Fargo.
- 7. First Amendment to Roberts Common Condominium – Declaration Establishing a Plan of Condominium Ownership and Pet Area Access Easement Agreement with DFI Roberts LLC.
- 8. Applications for property tax exemptions for improvements made to buildings:
  - a. Ellen and Rodney Shafer, 215 8th Street South (5 year).

- b. Mary Steussy, 301 20th Avenue North (5 year).
  - c. Paul J. and Ann L. Jarvis, 172 North Woodcrest Drive North (5 year).
  - d. Ryan and Krista French, 1226 Oak Street North (5 year).
  - e. Craig A. and Nichole L. Brandenburger, 1329 2nd Street North (5 year).
  - f. Nathan R. and Susan A. Brenneman, 3226 Bohnet Boulevard North (5 year).
  - g. Stephen J. and Nowelle Kisser, 1032 3rd Street North (5 year).
9. Applications for Games of Chance:
    - a. Lewis and Clark Elementary PTA for a raffle on 10/26/18.
    - b. Jefferson Elementary PTA for a raffle on 10/26/18.
    - c. Kappa Psi Pharmaceutical Fraternity for a raffle on 10/15/18.
    - d. Home Builders Care of Fargo-Moorhead Foundation for a raffle on 3/22/19.
    - e. Homeward Animal Shelter for a raffle on 10/19/18.
    - f. The Village Family Service Center for a raffle and raffle board on 11/16/18.
    - g. Eagles Elementary PTA for bingo on 10/16/18, 11/02/18, 2/1/19 and 4/5/19.
  10. 2019 City Commission meeting schedule.
  11. Bid award for food and beverage paper goods at the FARGODOME (RFP18241).
  12. First Amendment to Agreement with Ovations Food Services, LP d/b/a Spectra Food Services and Hospitality.
  13. Court Services Contract (Transfer of Municipal Cases for Jury Trial) with the State of North Dakota.
  14. Notice of Grant Award with the ND Department of Health for the WIC Program (CFDA #10.557).
  15. Notice of Grant Award with the ND Department of Health for Regional Public Health Network Implementation (CFDA #93.758).
  16. Grant Agreement with Lutheran Social Services of North Dakota for nurse case management for tuberculosis infection.
  17. Agreement for Services with Child Care Aware of North Dakota to provide training opportunities to licensed child care center staff to meet annual health code training requirements.
  18. Notice of Grant Award with the ND Department of Health for increasing breastfeeding rates/reducing overweight and obesity program (CFDA #93.994).
  19. Agreement for Services with the American Lung Association for tobacco prevention activities.
  20. Agreement for Services with ShareHouse for tobacco prevention activities.
  21. Agreement for Services with Southeast Human Service Center for tobacco prevention activities.
  22. Benefit renewals, as outlined, effective January 1, 2019.

23. Set November 5, 2018 at 5:15 p.m. as the date and time for a hearing on a dangerous building at 826 10th Street North.
24. Agreement with Plains Art Museum to provide the Bring Her Home exhibit at the Main Library.
25. Bid award for the purchase of one 4-ton hot patcher asphalt trailer (PBCSM1647C).
26. Request to extend the 2018/2019 snow hauling contracts with Master Construction, Diesel Dogs Trucking and Industrial Builders for the 2018/2019 snow season (RFP17012, RFP17013 and RFP17014).
27. Bid award for the purchase of one Spartan Fire Pumper (PBC18071).
28. Bid award for the Landfill Gas Compression Plant Expansion (Project No. SW16-03).
29. ND Department of Transportation State Aid for Public Transit Agreement in the amount of \$494,275.00 (Contract #38181487).
30. Section 5339 Bus and Bus Facilities Grant Program application.
31. Negative Final Balancing Change Order No. 3 in the amount of -\$21,266.18 for Project No. FM-14-63.
32. Change Order No. 2 for an increase of \$13,245.00 and a 13-day time extension for Project No. FM-15-F2.
33. Change Order No. 3 for an increase of \$2,023.68 for Project No. FM-15-K1.
34. Selection of AE2S to perform the electrical design services for Project No. MS-18-J0.
35. Engineering Services Agreement Amendment No. 1 with Houston Engineering in the amount of \$396,182.00 for Project No. FM-14-71.
36. Bid award for Project No. WA1753.
37. Sole Source Procurement with Hydro Klean for pipe cleaning at the Water Treatment Plant (SSP18163).
38. Change Order No. 20 for an increase of \$181,730.00 for the general construction contract Project No. WA1301.
39. Contracts and bonds for Project Nos. BP-00-43 and UR-18-A1.
40. Bills.
41. Memorandum of Offer to Landowner – Temporary Easement (Construction) with West Fargo Investments, LLC for Improvement District No. BN-19-A1.
42. Memorandum of Offer to Landowner – Temporary Easement (Construction) with Julie L. Vetter and Aaron D. Olson for Improvement District No. BN-19-A1.
43. Change Order No. 1 for an increase of \$145,301.00 for Improvement District No. BN-17-A3.

- Page 4
44. Negative Final Balancing Change Order No. 1 in the amount of -\$10,932.93 for Improvement District No. BR-16-E1.
  45. Change Order No. 1 for an increase of \$34,991.04 for Improvement District No. PR-18-C1.
  46. Change Order No. 1 for an increase of \$30,375.00 for Improvement District No. SL-17-B1.
  47. Time Extension to 5/1/18 for Improvement District No. BN-18-A1.
  48. Utility Relocation and authorize payment to Cable One in the amount of \$14,707.38 for Improvement District No. DN-18-A1.
  49. Early entry of Improvement District No. BN-19-A1 to the 2019 CIP.
  50. Create Improvement District No. BN-19-A.
  51. Bid award for Improvement District Nos. FM-14-8 and UN-18-C1.

**REGULAR AGENDA:**

52. Receive and file an Ordinance Enacting Article 39-01 of Chapter 39 of the Fargo Municipal Code Relating to Collection of Utilities and Services.
53. State Water Commission requests for Cost Reimbursement for FM Diversion Flood Project Costs:
  - a. Costs totaling \$9,786.00.
  - b. Costs totaling \$6,314.00.
54. Public Hearings - 5:15 pm:
  - a. CONTINUE to 11/5/18 - Application filed by Enclave Development LLC for a payment in lieu of tax exemption (PILOT) for a project located at 312 11th Street North, which the applicant will use in the operation of 60-75 housing units and amenity space; continued from the 8/27/18 and 9/10/18 Regular Meetings.
  - b. Text Amendment to amend Section 20-0504.G of Article 20-05, of the Fargo Municipal Code (Land Development Code), relating to the measurement of building height; approval recommended by the Planning Commission on 9/4/18.
    1. 1st reading of Ordinance.
  - c. Zoning Change from MR-1, Multi-Dwelling Residential to SR-5, Single-Dwelling Residential (2127 58th Avenue South); approval recommended by the Planning Commission on 9/4/18:
    1. 1st reading of rezoning Ordinance.
  - d. Larkin Addition (3949 37th Avenue South; 3555 and 3611 38th Street South; and 3552 and 3600 39th Street South); approval recommended by the Planning Commission on 5/1/18:
    1. Zoning Change from AG, Agricultural to LI, Limited Industrial.
    2. 1st reading of rezoning Ordinance.
    3. Plat of Larkin Addition.



- e. Special Assessment lists for the following Improvement Districts, all having been approved by the Special Assessment Commission on 9/5/18; set the interest rate at 1% per annum over the net rate on bonds financing said projects:
1. Park District Assessment Improvement District No. 7151.
  2. Park District Assessment Improvement District No. 7152.
  3. Park District Assessment Improvement District No. 7153.
  4. Park District Assessment Improvement District No. 7154.
  5. P.C. Concrete Alley Paving Improvement District No. AN-17-A.
  6. Sanitary Sewer, Water Main, Storm Sewer, Paving, Street Lights Improvement District No. BN-17-G.
  7. Sanitary Sewer, Water Main, Storm Sewer, Asphalt Paving, Concrete Curb and Gutter, Street Lights Improvement District No. BN-17-H.
  8. Water Main Replacement, Force Main Construction, Street Reconstruction Improvement District No. BR-16-C.
  9. Water Main Replacement, Force Main Construction, Street Reconstruction Improvement District No. BR-17-B.
  10. Flood Mitigation, Water Main Replacement, Force Main Construction, Street Reconstruction Improvement District No. FM-14-92.
  11. Flood Mitigation, Water Main Replacement, Force Main Construction, Street Reconstruction Improvement District No. FM-14-93.
  12. P.C. Concrete Pavement, Curb and Gutter, Storm Sewer, Sanitary Sewer, Water Main, Street Lighting Improvement District No. PN-15-A.
  13. P.C. Concrete Pavement, Bridge Widening, Storm Sewer, Sanitary Sewer, Water Main, Street Lighting, Traffic Signals Improvement District No. PR-17-A.
  14. Asphalt Mill and Overlay Improvement District No. PR-17-H.
  15. Street Lighting and Incidentals Improvement District No. SL-16-A.
  16. Street Lighting and Incidentals Improvement District No. SL-16-B.
  17. Street Lighting and Incidentals Improvement District No. SL-17-E.
  18. Street Lighting and Incidentals Improvement District No. SL-17-F.
  19. Street Lighting and Incidentals Improvement District No. SL-17-G.
  20. New Construction City Sidewalks Improvement District No. SN-17-A.

55. Recommendation for appointment to the Arts and Culture Commission.

People with disabilities who plan to attend the meeting and need special accommodations should contact the Commission Office at 701.241.1310. Please contact us at least 48 hours before the meeting to give our staff adequate time to make arrangements.

Minutes are available on the City of Fargo website at [www.FargoND.gov/citycommission](http://www.FargoND.gov/citycommission).



①

Office of the City Attorney

City Attorney  
Erik R. Johnson

Assistant City Attorney  
Nancy J. Morris

October 4, 2018

Board of City Commissioners  
City Hall  
225 4<sup>th</sup> Street North  
Fargo, ND 58102

**RE: Amendment of Section 23-0211 of the Electrical Code**

Dear Commissioners:

I am presenting to you today the enclosed ordinance amending Section 23-0211 of the Fargo Municipal Code that addresses the Electrical Code. This amendment has to do with the elimination of the language amending subsection 8 of the North Dakota State Wiring Standards and then adopting the 2017 National Electrical Code and amending subsection 10 of the North Dakota Administrative Code §24.1-06-02-10. I have worked with Bruce Taralson from the Inspections Department regarding this change. I have enclosed a draft amending ordinance for your consideration.

**SUGGESTED MOTION:** I move to amend the Ordinance Amending Section 23-0211 of Article 23-02 of Chapter 23 of the Fargo Municipal Code Relating to the Electrical Code and to place it on the agenda for the next regular meeting for second reading and final adoption.

Sincerely,

Erik R. Johnson

ERJ/lmw

Enclosure



OFFICE OF THE CITY ATTORNEY  
FARGO, NORTH DAKOTA

ORDINANCE NO. \_\_\_\_\_

AN ORDINANCE AMENDING SECTION 23-0211  
OF ARTICLE 23-02 OF CHAPTER 23 OF THE FARGO MUNICIPAL CODE  
RELATING TO THE ELECTRICAL CODE

WHEREAS, the electorate of the city of Fargo has adopted a home rule charter in accordance with Chapter 40-05.1 of the North Dakota Code; and,

WHEREAS, Section 40-05.1-06 of the North Dakota Century Code provides that the city shall have the right to implement home rule powers by ordinance; and,

WHEREAS, Section 40-05.1-05 of the North Dakota Century Code provides that said home rule charter and any ordinances made pursuant thereto shall supersede state laws in conflict therewith and shall be liberally construed for such purposes; and,

WHEREAS, the board of city commissioners deems it necessary and appropriate to implement such authority by the adoption of this ordinance; and,

WHEREAS, N.D.C.C. §43-09-21 authorizes cities to make wiring standards more stringent than those established by the state; and

NOW, THEREFORE,

Be It Ordained by the board of city commissioners of the city of Fargo:

Section 1. Amendment.

Section 23-0211 of Article 23-02 of Chapter 23 of the Fargo Municipal Code is hereby amended to read as follows:

23-0211. Installations must conform to certain regulations before certificate issued.--No certificate of approval shall be issued for electric light, power, and heating installations unless such installations are in strict conformity with the provisions of this chapter, the statutes of the state of North Dakota, the North Dakota State Wiring Standards, Article 24.1-06 of the North Dakota Administrative Code, as amended herein, the ordinances, rules and regulations issued by the board of city commissioners of the city of Fargo, under authority of the state statutes, and unless they are in conformity with approved methods of construction for safety to life and property. The regulations as laid down in the 2017 edition of the National Electrical Code as currently adopted by the State of North Dakota, as approved by the American Standards Association and in the National Electrical

OFFICE OF THE CITY ATTORNEY  
FARGO, NORTH DAKOTA

ORDINANCE NO. \_\_\_\_\_

1 Safety Code, as approved by the American Standards Association, and other installation and safety  
2 regulations approved by the American Standards Association, together with the current standards as  
3 published by the National Fire Protection Association, shall be prima facie evidence of such  
4 approved methods.

5 ~~Subsection 8 of the North Dakota State Wiring Standard §24-02-01-07 is hereby amended to~~  
6 ~~delete the "exception" so that said subsection 8 reads as follows:~~

7 ~~Where a fault circuit interrupter (AFCI) protection is required in article 210.12, 2014~~  
8 ~~edition, National Electrical Code, branch/feeder AFCIs shall be permitted to be used to meet the~~  
9 ~~requirements.~~

10 Section 2. Amendment.

11 With respect to the North Dakota State Wiring Standards, Article 24.1-06 of the North  
12 Dakota Administrative Code, as the same are adopted by reference, Subsection 10 of Section 24.1-  
13 06-02-10, is hereby amended to read:

14 10. Exception: 2017 edition, National Electrical Code, article 210.12(A): AFCI  
15 protection is ~~not~~ required for refrigeration appliances if one or more a single  
16 receptacles on a dedicated circuit is ~~are~~ installed.

17 Section 3. Effective Date.

18 This ordinance shall be in full force and effect from and after its passage and approval.

19 \_\_\_\_\_  
20 Timothy J. Mahoney, Mayor

21 Attest:

22 \_\_\_\_\_  
23 Steven Sprague, City Auditor

First Reading:  
Second Reading:  
Final Passage:

OFFICE OF THE CITY ATTORNEY  
FARGO, NORTH DAKOTA

20

ORDINANCE NO. \_\_\_\_\_

AN ORDINANCE AMENDING SECTION 8-1009 OF  
ARTICLE 8-10 OF CHAPTER 8 OF THE  
FARGO MUNICIPAL CODE  
RELATING TO PARKING REGULATIONS

1  
2  
3  
4  
5  
6  
7  
8  
9  
10  
11  
12  
13  
14  
15  
16  
17  
18  
19  
20  
21  
22  
23

WHEREAS, the electorate of the City of Fargo has adopted a home rule charter in accordance with Chapter 40-05.1 of the North Dakota Century Code; and

WHEREAS, Section 40-05.1-06 of the North Dakota Century Code provides that the City shall have the right to implement home rule powers by ordinance; and

WHEREAS, Section 40-05.1-05 of the North Dakota Century Code provides that said home rule charter and any ordinances made pursuant thereto shall supersede state laws in conflict therewith and shall be liberally construed for such purpose; and

WHEREAS, the Board of City Commissioners deems it necessary and appropriate to implement such authority by the adoption of this ordinance;

NOW, THEREFORE,

Be it Ordained by the Board of City Commissioners of the City of Fargo:

Section 1. Amendment.

Section 8-1009 of Article 8-10 of Chapter 8 of the Fargo Municipal Code is amended to read as follows:

8-1009. Night parking restrictions.—

- A. Within the central business district (from the Red River west to University Drive inclusive and from 5th Avenue North [Old Great Northern tracks, presently Burlington Northern Railroad tracks] to First Avenue South, inclusive), it shall be unlawful for any person to park any vehicle or trailer on any north-south street between the hours of 2:00 a.m. and 7:00 a.m. on Tuesdays, Thursdays, and Saturdays, or on any east-west avenue between the hours of 2:00 a.m. and 7:00 a.m. on Mondays, Wednesdays, Fridays, and Sundays. Any vehicle or trailer parked in violation of this section is hereby declared to be a public nuisance, and may be impounded by the police department.

OFFICE OF THE CITY ATTORNEY  
FARGO, NORTH DAKOTA

ORDINANCE NO. \_\_\_\_\_

1           B.     From November 1 of each year until April 15 of the following year, within  
2           the area of the city outside of the central business district from 19th Avenue  
3           North to 13th Avenue South, inclusive, and from the Red River to 25th  
4           Street North and South, inclusive, excluding the area between the Red River  
5           and 4<sup>th</sup> Street South, inclusive, from 6<sup>th</sup> Avenue South to 11<sup>th</sup> Avenue South,  
6           inclusive, and in any other area which is designated by appropriate signs, it  
7           shall be unlawful for any person to park any vehicle or trailer on any  
8           north-south street between the hours of 1:00 a.m. and 7:00 a.m. on Tuesdays,  
9           Thursdays, and Saturdays, or on any east-west avenue between the hours of  
10          1:00 a.m. and 7:00 a.m. on Mondays, Wednesdays, Fridays, and Sundays.  
11          Any vehicle or trailer parked in violation of this section is hereby declared to  
12          be a public nuisance, and may be impounded by the police department.

Section 2. Penalty.

A person who violates this ordinance shall be deemed to have committed a non-criminal offense and shall pay a fee of as provided in Section 1-0305 (12) of the Fargo Municipal Code, as the same may be amended from time to time.

Section 3. Effective Date.

This ordinance shall be in full force and effect from and after its passage, approval and publication.

\_\_\_\_\_  
Timothy J. Mahoney, Mayor

(SEAL)

Attest:  
  
\_\_\_\_\_  
Steven Sprague, City Auditor

First Reading:  
Second Reading:  
Final Passage:  
Publication:

OFFICE OF THE CITY ATTORNEY  
FARGO, NORTH DAKOTA

26

ORDINANCE NO. \_\_\_\_\_

AN ORDINANCE AMENDING SECTIONS 38-0101,  
38-0103, 38-0105, 38-0106 & 38-0107, OF ARTICLE 38-01 OF  
CHAPTER 38 OF THE FARGO MUNICIPAL CODE RELATING TO  
STREET LIGHTING AND TRAFFIC CONTROL DEVICES SYSTEM

WHEREAS, the electorate of the city of Fargo has adopted a home rule charter in accordance with Chapter 40-05.1 of the North Dakota Code; and,

WHEREAS, Section 40-05.1-06 of the North Dakota Century Code provides that the City shall have the right to implement home rule powers by ordinance; and,

WHEREAS, Section 40-05.1-05 of the North Dakota Century Code provides that said home rule charter and any ordinances made pursuant thereto shall supersede state laws in conflict therewith and shall be liberally construed for such purposes; and,

WHEREAS, the Board of City Commissioners deems it necessary and appropriate to implement such authority by the adoption of this ordinance;

NOW, THEREFORE,

Be It Ordained by the Board of City Commissioners of the City of Fargo:

Section 1. Amendment.

Section 38-0101 of Article 38-01 of Chapter 38 of the Fargo Municipal Code is hereby amended to read as follows:

38-0101. Creation of Street Lighting System and Traffic Control Devices System Utility.--Pursuant to the provisions of Section 40-05-01 and Chapter 40-05, N.D.C.C, all lands, easements, rights in land, facilities, poles, wires, cables, conduits and other electrical fixtures and equipment necessary for the proper maintenance and operation thereof heretofore or hereafter acquired by purchase, lease or otherwise and set aside by the board of city commissioners of the city of Fargo for a municipal street lighting system and traffic control devices system are hereby declared to be and shall henceforth constitute, be held, operated, maintained, improved, enlarged, and administered as a single system to be known as the street lighting system and traffic control devices system.

OFFICE OF THE CITY ATTORNEY  
FARGO, NORTH DAKOTA

ORDINANCE NO. \_\_\_\_\_

1  
2  
3  
4  
5  
6  
7  
8  
9  
10  
11  
12  
13  
14  
15  
16  
17  
18  
19  
20  
21  
22  
23

Section 2. Amendment.

Section 38-0103 of Article 38-01 of Chapter 38 of the Fargo Municipal Code is hereby amended to read as follows:

~~38-0103. Rates and Charges to Be Established.--In order to provide funds to defray the costs operating, maintaining and repairing the street lighting system and traffic control devices system and to provide for related revenue transfers, the board of city commissioners shall from time to time determine, establish, maintain and change, by resolution, a schedule of rates, charges and fees for all services, facilities and benefits furnished by the street lighting system and traffic control devices system.~~

Section 3. Amendment.

Section 38-0105 of Article 38-01 of Chapter 38 of the Fargo Municipal Code is hereby amended to read as follows:

38-0105. System to Be Self Supporting.--The street lighting system and traffic control devices system shall be operated and maintained, and the rates and charges for use of the facilities, shall be such as to make the system self-supporting, self-perpetuating and adequate to pay all of the costs of operations and maintenance of the system, to fund the acquisition of capital equipment needed to maintain the system assets, to provide for revenue transfers approved during the annual budget adoption, to provide a reasonable operating reserves and to pay all obligations of the city incurred in establishing, improving and extending the system provided, however, nothing herein shall be deemed or construed to preclude the city from defraying all or any part of the expense of the operation or of any improvement or extension of the system by the levy of special assessments, or taxes, or to preclude the city from issuing general obligation bonds, whenever and to the extent that such action is authorized in a manner provided by law and is deemed fair and equitable by the board of city commissioners.



OFFICE OF THE CITY ATTORNEY  
FARGO, NORTH DAKOTA

ORDINANCE NO. \_\_\_\_\_

Section 4. Amendment.

Section 38-0106 of Article 38-01 of Chapter 38 of the Fargo Municipal Code is hereby amended to read as follows:

38-0106. Segregation of City of Fargo Street Lighting and Traffic Control Devices Fund.--All moneys received by the city in respect of the service and facilities furnished and made available by the system shall be paid into the treasury of the city and kept in a utility fund which shall be permanently maintained on the books of the city, separate and distinct from other funds, shall be considered a non-major utility fund for financial reporting and budgeting purposes, and shall be designated as the Street Lighting System and Traffic Control Devices System Fund.

Section 5. Amendment.

Section 38-0107 of Article 38-01 of Chapter 38 of the Fargo Municipal Code is hereby amended to read as follows:

38-0107. Installation of Street Lights and Traffic Control Devices.--The board of city commissioners may, from time to time, designate where street lights and traffic control devices shall be installed and the manner and procedures to be followed in making such installations. The city engineer shall be responsible for the regulation, control, maintenance, and expansion of the street lighting system and traffic control devices system.

Section 6. Effective Date.

This ordinance shall be in full force and effect from and after its passage and approval.

\_\_\_\_\_  
Timothy J. Mahoney, Mayor

Attest:

\_\_\_\_\_  
Steven Sprague, City Auditor

First Reading:  
Second Reading:  
Final Passage:

OFFICE OF THE CITY ATTORNEY  
FARGO, NORTH DAKOTA

3a

ORDINANCE NO. \_\_\_\_\_

AN ORDINANCE AMENDING SECTION 8-1425, OF ARTICLE 8-14  
OF CHAPTER 8 OF THE FARGO MUNICIPAL CODE RELATING TO  
BICYCLES

WHEREAS, the electorate of the city of Fargo has adopted a home rule charter in accordance with Chapter 40-05.1 of the North Dakota Code; and,

WHEREAS, Section 40-05.1-06 of the North Dakota Century Code provides that the City shall have the right to implement home rule powers by ordinance; and,

WHEREAS, Section 40-05.1-05 of the North Dakota Century Code provides that said home rule charter and any ordinances made pursuant thereto shall supersede state laws in conflict therewith and shall be liberally construed for such purposes; and,

WHEREAS, the Board of City Commissioners deems it necessary and appropriate to implement such authority by the adoption of this ordinance;

NOW, THEREFORE,

Be It Ordained by the Board of City Commissioners of the City of Fargo:

Section 1. Amendment.

Section 8-1425 of Article 8-14 of Chapter 8 of the Fargo Municipal Code is hereby amended to read as follows:

Penalties imposed.--All persons convicted of (violating) any provisions of this chapter (article) shall be punished by a fine not to exceed \$5 found to have violated provisions of this Chapter shall be punished as stated in section 01-0305 (C)(1)(2) or (5).

OFFICE OF THE CITY ATTORNEY  
FARGO, NORTH DAKOTA

ORDINANCE NO. \_\_\_\_\_

Section 2. Effective Date.

1  
2  
3  
4  
5  
6  
7  
8  
9  
10  
11  
12  
13  
14  
15  
16  
17  
18  
19  
20  
21  
22  
23

This ordinance shall be in full force and effect from and after its passage and approval.

\_\_\_\_\_  
Timothy J. Mahoney, Mayor

Attest:

\_\_\_\_\_  
Steven Sprague, City Auditor

First Reading:  
Second Reading:  
Final Passage:

OFFICE OF THE CITY ATTORNEY  
FARGO, NORTH DAKOTA

36

ORDINANCE NO. \_\_\_\_\_

AN ORDINANCE AMENDING SECTION 01-0305, OF ARTICLE 01-03 OF CHAPTER 01 OF THE FARGO MUNICIPAL CODE RELATING TO GENERAL PROVISIONS

WHEREAS, the electorate of the city of Fargo has adopted a home rule charter in accordance with Chapter 40-05.1 of the North Dakota Code; and,

WHEREAS, Section 40-05.1-06 of the North Dakota Century Code provides that the City shall have the right to implement home rule powers by ordinance; and,

WHEREAS, Section 40-05.1-05 of the North Dakota Century Code provides that said home rule charter and any ordinances made pursuant thereto shall supersede state laws in conflict therewith and shall be liberally construed for such purposes; and,

WHEREAS, the Board of City Commissioners deems it necessary and appropriate to implement such authority by the adoption of this ordinance;

NOW, THEREFORE,

Be It Ordained by the Board of City Commissioners of the City of Fargo:

Section 1. Amendment.

Section 01-0305 of Article 01-03 of Chapter 01 of the Fargo Municipal Code is hereby amended to read as follows:

C. Violations of the following ordinances are noncriminal offenses and shall require payment of a fee as follows:

- 1. For a violation of the following ordinances, a fee of \$5.00.  
~~Section 8-1411 (bicyclist to obey traffic control devices),~~ section 8-1412 (riders/passengers restricted), section 8-1413 (riding on roadway/bike paths--restrictions), section 8-1414 (operate bicycle too fast for conditions), section 8-1416 (carrying packages--restrictions), ~~section 8-1418 (riding bicycle on sidewalks--restrictions),~~ section 8-1419 (equipment on bicycles), section 8-1420 (bicycles- age restrictions).

OFFICE OF THE CITY ATTORNEY  
FARGO, NORTH DAKOTA

ORDINANCE NO. \_\_\_\_\_

1  
2  
3  
4  
5  
6  
7  
8  
9  
10  
11  
12  
13  
14  
15  
16  
17  
18  
19  
20  
21  
22  
23

2. For a violation of the following ordinances, a fee of \$20.00. Section 8-0105 (driving wrong way on one-way street), section 8-0106 (obey temporary traffic sign/barrier), section 8-0113 (unlawful use of skates/coasters), section 8-0303(B) (parent/guardian allow unlicensed/under 16 to drive), section 8-0303(C) (owner allowing unlicensed/under 16 to drive), section 8-0304 (registration card to be carried in the driver's compartment-- inspection of card), section 8-0305(a)(1), section 8-0305(A)(4) (current registration required), section 8-0305(B) (current license required), section 8-0306 (violation of restricted license), section 8-0316 (permit unauthorized person to drive), section 8-0318 (operating motor vehicle on bicycle trail), section 8-0403 (disobey traffic control device (barricade)), section 8-0405 (traffic control signals), section 8-0406 (pedestrian-control signal), section 8-0407 (flashing signals), section 8-0411 (alter traffic or railroad sign), section 8-0412 (display unauthorized signs, signals or marking), section 8-0506 (impeding traffic), article 8-06 (regulating turning movements), section 8-0707 (pedestrian crossing street where prohibited), section 8-0709(A) (pedestrian walking in roadway), section 8-0710 (pedestrian soliciting rides or business), section 8-0712 (pedestrian obstructing traffic), section 8-0901 (fail to display flag/light rear of load), section 8-0902 (improper tires), section 8-0903 (improper horn), section 8-0904 (brakes required), section 8-0905 (mirrors required), section 8-0906 (obstructed vehicle windshield/windows), section 8-0907 (windshield wipers required), 8-0908 (mufflers/exhaust system required), section 8-0909 (leaking or loose load), section 8-0910 (lights/lamps fail to conform to state law), section 8-0911 (fail to display lighted lamps), section 8-0913 (illegal spotlights), section 8-0914 (improper towing connection), section 8-0915 (reflectors/taillight required on trailer), section 8-0916 (flashing lights prohibited), section 8-0917 (illegal light on vehicle), section 8-0919(A) (riding on exterior of vehicle), section 8-0919(B) (more passengers than capacity), section 8-0919 (C) (allow body to protrude from moving vehicle), section 8-0928 (modified suspension system), section 8-0929 (driving of vehicle in unsafe condition unlawful), section 8-1003 (A) thru (J) and (L) thru (S) (stopping, standing, parking prohibited in specific places), section 8-1010 (motor vehicle left unattended-- brakes to be set, engine stopped, and keys removed), section 8-1011 (drive or park on private property), section 8-1013 (improper parking/obstructing traffic), section 8-1111 (vehicle required to stop at railroad crossing), section 8-1201 (following too closely), sections 8-1202 thru 8-1218(D) (general rules of the road), section 8-1301(A) (following fire apparatus), section 8-1301(B) (driving vehicle within block of fire apparatus), section 8-

OFFICE OF THE CITY ATTORNEY  
FARGO, NORTH DAKOTA

ORDINANCE NO. \_\_\_\_\_

1301(C) (driving over fire hose), section 8-1301(D) (driving through/around barricade), section 8-1302 (driving through parade/funeral procession), section 8-1304 (failure to obtain parade permit), section 8-1305 (driving vehicle on sidewalk), section 8-1306 (improper backing), section 8-1307 (opening and closing vehicle doors), 8-1308 (helmet required-- operator/passenger), section 8-1309 (number of riders on motorcycle limited), section 8-1310 (clinging to a vehicle or allowing same), section 8-1311 (improper start of parked vehicle), ~~section 8-1313 (unlawful riding on vehicle), section 8-1315 (unlawful towing),~~ section 8-1316(A) (operating motor vehicle with view obstructed by load/passengers), section 8-1316(B) (passenger obstructing driver's view), section 8-1317 (coasting vehicle on downgrade prohibited), section 8-1318 (littering), section 8-1319 (unlawful operation of motor vehicle private property), section 8-1320(A) (operating snowmobile under 16 or allowing when prohibited), section 8-1320(B) (operating snowmobile in restricted area), section 8-1321 (use of seat belts required), section 8-1410 (traffic laws apply to persons riding bicycles), section 8-1411 (bicyclist to obey traffic control devices), section 8-1418 (riding bicycle on sidewalks – restrictions), section 8-1422 (bicycle accidents), section 8-1804 (driving through school patrols), section 8-1902 (cruising prohibited), article 8-20 (motorized scooters).

- 3. For a violation of the following ordinance, a fee of \$25.00.  
Section 8-0931 (child restraint devices required), section 10-0103(B) (tobacco possession by minors prohibited).
- 4. For a violation of the following ordinances, a fee of \$30.00.  
Section 8-0301 (failure to have vehicle under control), section 8-03013 (careless driving), section 8-0501 (speed-care required).
- 5. For a violation of the following ordinances a fee of \$40.00.  
Section 8-1018 (taking on or discharging passengers), ~~section 8-1403 (D) (failure to register/display license on bike),~~ section 8-1415 (right-of-way emerging from alley or driveway), section 8-1417 (parking restriction), ~~section 8-1420 (bicycles-age restrictions).~~

OFFICE OF THE CITY ATTORNEY  
FARGO, NORTH DAKOTA

ORDINANCE NO. \_\_\_\_\_

1  
2  
3  
4  
5  
6  
7  
8  
9  
10  
11  
12  
13  
14  
15  
16  
17  
18  
19  
20  
21  
22  
23

Section 2. Effective Date.

This ordinance shall be in full force and effect from and after its passage and approval.

\_\_\_\_\_  
Timothy J. Mahoney, Mayor

Attest:

\_\_\_\_\_  
Steven Sprague, City Auditor

First Reading:  
Second Reading:  
Final Passage:

OFFICE OF THE CITY ATTORNEY  
FARGO, NORTH DAKOTA

30

ORDINANCE NO. \_\_\_\_\_

AN ORDINANCE ENACTING ARTICLE 3-23 OF CHAPTER 3  
OF THE FARGO MUNICIPAL CODE RELATING TO COLLECTION OF  
UTILITIES AND SERVICES

1  
2  
3  
4  
5  
6  
7  
8  
9  
10  
11  
12  
13  
14  
15  
16  
17  
18  
19  
20  
21  
22  
23

WHEREAS, the electorate of the city of Fargo has adopted a home rule charter in accordance with Chapter 40-05.1 of the North Dakota Century Code; and

~~WHEREAS, Section 40-05.1-06 of the North Dakota Century Code provides that the city shall have the right to implement home rule powers by ordinance; and~~

WHEREAS, Section 40-05.1-05 of the North Dakota Century Code provides that said home rule charter and any ordinances made pursuant thereto shall supersede state laws in conflict therewith and shall be liberally construed for such purpose; and

WHEREAS, the board of city commissioners deems it necessary and appropriate to implement such authority by the adoption of this ordinance;

NOW, THEREFORE,

Be It Ordained by the board of city commissioners of the city of Fargo:

Section 1. Enactment.

Article 3-23 of Chapter 3 of the Fargo Municipal Code is hereby enacted as follows:

ARTICLE 3-23 – COLLECTION OF  
UTILITIES AND SERVICES

Section 3-2301 – Tenant and Owner Jointly and Severally Liable. -- The owner and occupant of each premise shall be jointly and severally liable for all charges for all municipal utilities and services provided to the property, including but not limited to water, sanitary sewer, street lighting, vector control, solid waste, forestry, and storm water service during the period of their respective ownership or occupancy.

Section 3-2302 – Charges to Constitute Lien on Premises; Assessment and Collection of Lien. -- All unpaid municipal utilities and services shall constitute a lien upon the respective lots, tracts and premises receiving such utility or service; and all such charges which have been properly billed to the owner or occupant of the premises served and which are more than thirty days past



OFFICE OF THE CITY ATTORNEY  
FARGO, NORTH DAKOTA

ORDINANCE NO. \_\_\_\_\_

due may be charged as an assessment against the lot or parcel of land. In August of each year the board of city commissioners shall review all assessments, and hear all complaints against the same, and approve the same as finally adjusted, and the city, in so certifying such charges, shall specify the amount thereof, the description of the premises served and the name of the owner thereof. The amount so certified shall be extended by the county on the tax rolls against such premises and collected by the county and paid to the city in the same manner as other county and municipal taxes are assessed, certified, collected and returned.

Section 2. Effective Date.

This ordinance shall be in full force and effect from and after its passage, approval and publication.

\_\_\_\_\_  
Timothy J. Mahoney, Mayor

(SEAL)

Attest:

First Reading:  
Second Reading:  
Final Passage:

\_\_\_\_\_  
Steven Sprague, City Auditor



4

Office of the City Attorney

City Attorney  
Erik R. Johnson

Assistant City Attorney  
Nancy J. Morris

October 4, 2018

Board of City Commissioners  
City Hall  
225 Fourth Street North  
Fargo, ND 58102

**RE: Agreement for Removal of Glass Pile – Dak Real Estate Holdings, Inc.**

Dear Commissioners,

Enclosed for your review and approval is an agreement with Dak Real Estate Holdings, Inc. (“Dak”) pertaining to the excavation of a pile of crushed glass, pursued by city health officials as a health concern and, possibly, a nuisance. Dak has entered into a purchase agreement for the property containing the glass pile material. Once Dak obtains title to this property, Dak intends to abate the alleged nuisance by excavating the glass pile material and hauling said material to the City landfill.

**SUGGESTED MOTION:** I move to approve the glass pile agreement as presented.

Please feel free to contact me if you have any questions or concerns.

Sincerely,

Alissa R. Farol

Enclosure

cc: Grant Larson  
Terry Ludlum  
Daniel Kraemer



**AGREEMENT**

**(Hoffman Glass Pile)**

**This agreement** (hereinafter “Agreement”) is made and entered into this 9<sup>th</sup> day of October, 2018, by and between the **City of Fargo**, a North Dakota municipal corporation (hereinafter “City”), and **Dak Real Estate Holdings, Inc.**, a North Dakota corporation (hereinafter “Dak”).

**WHEREAS**, there exists a pile of crushed or pulverized glass and other materials [herein after the “Glass Pile”] located at 3820 3<sup>rd</sup> Avenue North, Fargo, North Dakota 58102, the legal description for which is as follows:

South 103 Feet of Lot Three (3), in Block Four (4), of E G Clapp 1<sup>st</sup> Addition to the city of Fargo, County of Cass and State of North Dakota;

[hereinafter the “Subject Property”] which glass pile has been alleged by City officials as being a public nuisance; and

**WHEREAS**, Dak has entered into a purchase agreement for the purchase of the Subject Property with the apparent record title owner, which purchase agreement calls for a closing to occur on or before the 30 day of Nov, 2018, at which closing Dak will become the record title owner; and

**WHEREAS**, once Dak obtains title to the Subject Property, Dak wishes to abate the alleged nuisance by excavating the material in the Glass Pile along with the sub-base below the Glass Pile, and hauling said material to the sanitary landfill site operated by the City of Fargo located at 4501 7<sup>th</sup> Avenue North, Fargo, North Dakota [hereinafter the “City Landfill”]; and,

**WHEREAS**, the City is willing to accept from Dak the Glass Pile and the sub-base at said landfill and to waive customary tipping fees provided certain conditions have been met and Dak has conditioned its obligation to close the purchase agreement transaction upon Dak and the City having entered into a suitable agreement; and,

**NOW, THEREFOR**, in consideration of the mutual covenants and agreements contained herein, the parties agree as follows:

1. At such time as Dak is granted ownership of the Subject Property, Dak will excavate the Glass Pile and such sub-base beneath the Glass Pile as Dak may choose to excavate (to a depth no deeper than one (1) foot below established grade) and to haul said material to the City Landfill. Dak shall use its best efforts to separately excavate and haul the material in the Glass Pile from the sub-base beneath the Glass Pile. Dak shall undertake such excavation and hauling at Dak’s sole expense. Dak shall provide reasonable notice, delivered either in writing or by telephone, to the Landfill

Supervisor (currently, Paul Hanson) or other appropriate official, said notice being delivered at least 24 hours in advance of Dak's intended haul of material to the City Landfill.

2. City will accept the Glass Pile material, including the described sub-base material at the City Landfill and hereby waives the City's customary tipping fee or fees, the City recognizing that the City will derive certain beneficial use of the Glass Pile material as a filter medium in the City Landfill.
3. At such time as the Glass Pile is removed and transported fully, as described herein, City agrees that it will consider the alleged nuisance created by the presence of the Glass Pile as having been fully abated and City shall take no further action, civil or criminal, regarding the presence of the Glass Pile material on the Subject Property. Further, the Health Department of the state of North Dakota has provided assurance that at such time as the Glass Pile is removed and transported fully, as described herein, the Health Department has represented that it will conduct a site visit to confirm the removal of the Glass Pile and would further thereafter expect to close its file on the matter, therefore being deemed resolved.
4. Dak agrees that Dak will complete the excavation and hauling of the Glass Pile material on or before June 30, 2019. In such event that the Glass Pile has not been fully removed as described herein by June 30, 2019, the City shall be authorized to enter upon the Subject Property and abate the alleged nuisance by excavating and hauling the Glass Pile material with the City gaining access to the Subject Property by way of adjacent property that is owned by Dak which adjacent property is legally described as:

Lots Four (4) and Five (5), in Block Four (4), of Replat of Part of E G Clapp 1<sup>st</sup> Addition to the city of Fargo, County of Cass and State of North Dakota;

[hereinafter the "Dak Adjacent Property"], the address for which is 3902 3<sup>rd</sup> Avenue North and Dak hereby GRANTS to the City a temporary easement across the Dak Adjacent Property for such purposes and Dak hereby agrees that the reasonable costs incurred by the City in excavating the Glass Pile material, hauling said material to the City Landfill, including any reasonable administrative costs and legal expenses shall be borne by Dak, with the City being authorized to invoice said costs and expenses to Dak at its address and if said invoice is not paid within sixty (60) days, the City is hereby authorized to assess said costs and expenses against the Subject Property and to the Dak Adjacent Property in the same way as costs incurred for the abatement of

nuisances are authorized to be assessed against property as provided by city ordinance and state nuisance law.

5. Contingency. That the obligations of Dak and of the City as set forth herein are contingent upon Dak becoming the record title holder to the above-described subject property, said event presumably occurring upon the closing of the above-described purchase agreement. As such, in the event Dak does not obtain record title ownership of the Subject Property on or before June 30, 2019, this Agreement shall become null, void and no further force or effect.
6. Successors and Assigns. This Agreement shall be binding on and inure to the benefit of the parties hereto and the assigns, personal representatives, heirs, and successors of the parties.
7. Agreement to Run with the Land and Recording Memorandum of Agreement. This Agreement shall run with the land, and shall be binding upon Dak and its successors in interest in the Subject Property and the Dak Adjacent Property. The City is hereby authorized to execute and record a memorandum of this Agreement against the Subject Property and against the Dak Adjacent Property with the Office of the Recorder, Cass County North Dakota, in a form substantially similar to the form of Memorandum attached hereto as Exhibit "A" at any time after the closing of the above-described purchase agreement. Further, Dak agrees to apprise any buyers or intended assigns of the existence and content of this Agreement. Once Dak has fulfilled its obligations regarding the removal of the Glass Pile as contemplated herein, the City will issue a certificate of completion and release of the Memorandum of Agreement to be recorded against the same property.
8. This Agreement will be construed and enforced in accordance with North Dakota law. The parties agree any litigation arising out of this Agreement will be venued in District Court in Cass County, North Dakota, and the parties waive any objection to personal jurisdiction.
9. The failure or delay of the City to insist on the performance of any of the terms of this Agreement, or the waiver of any breach of any of the terms of this Agreement, will not be construed as a waiver of those terms, and those terms will continue and remain in full force and effect as if no forbearance or waiver had occurred and will not affect the validity of this Agreement, or the right of the City to enforce each and every term of this Agreement.
10. If any court of competent jurisdiction finds any provision or part of this Agreement is invalid, illegal, or unenforceable, that portion will be deemed severed from this

Agreement, and all remaining terms and provisions of this Agreement will remain binding and enforceable, and the parties' obligations under this Agreement will remain binding and enforceable.

11. This Agreement, together with any related documents, as well as any amendments to those agreements and documents, constitutes the entire agreement between the parties regarding the matters described in this Agreement.

12. Any modifications or amendments of this Agreement must be in writing and signed by both parties to this Agreement.

13. Effective Date. This Agreement shall be deemed effective as of the date and year first above written.

**IN WITNESS WHEREOF**, the parties hereto execute this Agreement as follows.

CITY OF FARGO,  
a North Dakota municipal corporation

\_\_\_\_\_  
Timothy J. Mahoney, M.D., Mayor

ATTEST:

\_\_\_\_\_  
Steven Sprague, City Auditor

STATE OF NORTH DAKOTA     )  
   ) ss.  
COUNTY OF CASS             )

On this \_\_\_\_\_ day of \_\_\_\_\_, 2018, before me, personally appeared, \_\_\_\_\_ known to me to be the Mayor and City Auditor of the municipal corporation that is described in and that executed the foregoing instrument, and acknowledged that such municipal corporation executed the same.

(SEAL)

\_\_\_\_\_  
Notary Public  
Cass County, North Dakota

DAK REAL ESTATE HOLDINGS, INC.

*Daniel Kraemer*  
Daniel Kraemer  
President

DATE: 10/3/18

STATE OF NORTH DAKOTA    )  
  ) ss.  
COUNTY OF CASS            )

On this 3<sup>rd</sup> day of October, 2018, before me, personally appeared, Daniel Kraemer, President of DAK REAL ESTATE HOLDINGS, INC., known to me to be the person who is described in and that executed the foregoing instrument, and acknowledged to me that he executed the same on behalf of said company.

(SEAL)

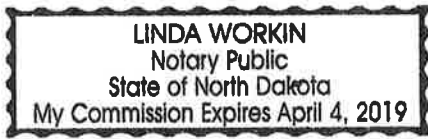

*Linda Workin*  
Notary Public  
Cass County, North Dakota



⑤

## Office of the City Attorney

City Attorney  
Erik R. Johnson

October 4, 2018

Assistant City Attorney  
Nancy J. MorrisBoard of City Commissioners  
City Hall  
225 4<sup>th</sup> Street North  
Fargo, ND 58102**RE: Oak-Grove/Park Christian High Schools' Land (South of 52<sup>nd</sup> Ave. S.)**

Dear Commissioners:

Enclosed for your review and approval is an agreement for the release of a "flowage easement" across land now owned by Oak Grove Foundation Properties, LLC and Park Christian School, Inc. As a brief explanation, the City, Southeast Cass Water Resource District and the State of North Dakota obtained a flowage easement across this property and other property lying between the Sheyenne River and Drain No. 27. The easement was obtained in the early 1980's and, at that time, the flowage easement was utilized by the city of Fargo to transfer water overland by diverting water taken from the Sheyenne River (the city of Fargo has certain rights to the Sheyenne River and water held behind Baldhill Dam) into the Red River via said Drain 27. Of course, since that time, the City has replaced this overland flow mechanism for capturing Sheyenne River water with an enclosed pipeline system taking the water directly to the Water Plant on 13<sup>th</sup> Avenue South. As a result, the flowage easement no longer serves its originally-intended purpose. The City, has in the past, agreed to release the flowage easement upon repayment to the City of the unit price of \$167 per acre, plus simple interest at the rate of 3% per annum since May of 1983, such arrangement having been entered into between the City and other property owners for property between the Sheyenne River and Drain 27. In this case Oak Grove and Park Christian are also requesting approval from Southeast Cass and from the State of North Dakota and we anticipate such approval being granted. Enclosed for your review and approval is an Easement Release Agreement setting the terms for such release of the flowage easement.

**SUGGESTED MOTION:** I move to approve the Easement Release Agreement between the city of Fargo, Southeast Cass Water Resource District and the State of North Dakota and Oak Grove Foundation Properties, LLC and Park Christian School, Inc., as presented.

Sincerely,

A handwritten signature in black ink, appearing to be "ERJ", written over a large, stylized circular flourish.

Erik R. Johnson

ERJ/lmw  
Enclosure



## **EASEMENT RELEASE AGREEMENT**

**THIS EASEMENT RELEASE AGREEMENT** (the "Agreement") is made and entered into as of the 10<sup>th</sup> day of October, 2018, by and among CITY OF FARGO, NORTH DAKOTA, a North Dakota municipal corporation ("City"), SOUTHEAST CASS WATER RESOURCE DISTRICT, a North Dakota political subdivision, as successor of Cass County Drain Board ("SECWRD"), STATE OF NORTH DAKOTA (the "State"), OAK GROVE FOUNDATION PROPERTIES, LLC, a North Dakota limited liability company ("OG"), and PARK CHRISTIAN SCHOOL, INC., a Minnesota non-profit corporation ("Park"). City, SECWRD and the State are sometimes hereafter referred to, collectively, as the "Easement Holders", and OG and Park are sometimes hereafter referred to, collectively, as "OGPC".

### **RECITALS**

- A. Easement Holders obtained from Melvin O. Arneson, Vernon S. Arneson, Arnold T. Arneson, Gerhard H. Arneson and Gladys S. Arneson, an easement over certain real property pursuant to an easement, dated May 16, 1983, and recorded in the office of the Cass County Register of Deeds, now Recorder, in Book "M-9", of Miscellaneous, at page 501 (the "Easement").
- B. Easement Holders have, on prior occasions, released certain property from the Easement.
- C. Easement Holders have agreed to release the Easement as to certain real property owned by OGPC described on attached Exhibit A (the "Property"), subject to the terms and conditions set forth in this Agreement.

### **AGREEMENTS**

**NOW, THEREFORE**, in consideration of the Recitals and the following mutual agreements, the parties agree as follows:

- 1. Upon payment to City at a unit price of \$167.00 per acre, which sum is equal to the price originally paid by Easement Holders, together with interest thereon at the rate of 3% per annum (not compounded) since May 16, 1983 (the "Release Amount"), City will execute and deliver to OGPC a release for all or such portion of the Property for which the

Release Amount has been paid in the form attached hereto as Exhibit B (the "Release"). Interest for a partial year shall be prorated to the date of payment.

2. SECWRD and the State hereby authorize City, upon City's receipt of the Release Amount, to execute the Release pertaining to such applicable portion of the Property without the need for SECWRD and the State to further approve same or join therein, and City's execution thereof shall be deemed conclusive evidence of SECWRD's and State's release of any right, title or interest under the Easement.
3. This Agreement contains the entire understanding of the parties and inures to and is binding upon their respective successors and assigns. No modification or waiver of this Agreement or of any covenant, condition or provision herein contained shall be valid unless in writing and duly executed by the party to be charged therewith; provided, however, City is authorized by all Easement Holders to amend this Agreement on their behalf, and any such amendment signed by City shall bind all Easement Holders.

**IN WITNESS WHEREOF**, the parties have executed this Agreement the day and year first above written.

*[the remainder of this page intentionally left blank – signature pages follow]*

**CITY OF FARGO, NORTH DAKOTA**

By: \_\_\_\_\_  
Timothy J. Mahoney, Mayor

ATTEST:

\_\_\_\_\_  
Steve Sprague, City Auditor

STATE OF NORTH DAKOTA     )  
  ) SS  
COUNTY OF CASS             )

On this \_\_\_\_\_ day of \_\_\_\_\_, 2018, before me, a notary public in and for said state, personally appeared Timothy J. Mahoney and Steve Sprague, known to me to be the Mayor and City Auditor, respectively, of the City of Fargo, a North Dakota municipal corporation, described in and who executed the foregoing Agreement and acknowledged that they executed the same on behalf of the corporation, as the free act and deed of the municipal corporation.

\_\_\_\_\_  
Notary Public

**SOUTHEAST CASS WATER  
RESOURCE DISTRICT**

By: \_\_\_\_\_  
Dan Jacobson, Chairman

ATTEST:

\_\_\_\_\_  
Carol Harbeke Lewis, Secretary

STATE OF North Dakota            )  
  ) SS  
COUNTY OF Cass                    )

On this \_\_\_\_\_ day of \_\_\_\_\_, 2018, before me, a notary public in and for said state, personally appeared Dan Jacobson and Carol Harbeke Lewis, known to me to be the Chairman and Secretary, respectively, of Southeast Cass Water Resource District, a North Dakota political subdivision, described in and who executed the foregoing Agreement and acknowledged that they executed the same on behalf of the corporation, as the free act and deed of the political subdivision.

\_\_\_\_\_  
Notary Public

STATE OF NORTH DAKOTA

By: \_\_\_\_\_  
Doug Burgum, Governor

ATTEST:

\_\_\_\_\_  
Alvin A. Jaeger, Secretary of State

STATE OF NORTH DAKOTA     )  
  ) SS  
COUNTY OF BURLEIGH     )

On this \_\_\_\_\_ day of \_\_\_\_\_, 2018, before me, a notary public in and for said state, personally appeared Doug Burgum and Alvin A. Jaeger, known to me to be the Governor and Secretary of State, respectively, of the State of North Dakota, described in and who executed the foregoing Agreement and acknowledged that they executed the same on behalf of the State of North Dakota, as the free act and deed of such State of North Dakota.

\_\_\_\_\_  
Notary Public

OAK GROVE FOUNDATION PROPERTIES, LLC

By: \_\_\_\_\_

Its: \_\_\_\_\_

STATE OF NORTH DAKOTA     )  
  )  
  ) ss  
COUNTY OF CASS             )

On this \_\_\_\_\_ day of \_\_\_\_\_, 2018, before me, a notary public within and for said State, personally appeared \_\_\_\_\_, known to me to be the \_\_\_\_\_ of Oak Grove Foundation Properties, LLC, a North Dakota limited liability company, described in and who executed the foregoing Agreement and acknowledged that \_\_\_\_\_ executed the same on behalf of the Company, as the free act and deed of the limited liability company.

\_\_\_\_\_  
Notary Public

PARK CHRISTIAN SCHOOL, INC.

By: \_\_\_\_\_

Its: \_\_\_\_\_

STATE OF NORTH DAKOTA    )  
  ) ss  
COUNTY OF CASS            )

On this \_\_\_\_\_ day of \_\_\_\_\_, 2018, before me, a notary public within and for said County, personally appeared \_\_\_\_\_, to me known to be the \_\_\_\_\_ of Park Christian School, Inc., a Minnesota non-profit corporation, described in and who executed the foregoing Agreement and acknowledged that he executed the same on behalf of the corporation, as the free act and deed of the non-profit corporation.

\_\_\_\_\_  
Notary Public

EXHIBIT A

LEGAL DESCRIPTION

Tract One: All that part of the Northwest Quarter (NW¼) of Section Four (4), Township One Hundred Thirty-eight (138) North, Range Forty-nine (49) West of the Fifth Principal Meridian, Cass County, North Dakota, lying South and East of Cass County Drain No. 27,

LESS: That part of the Northwest Quarter of Section 4, Township 138 North, Range 49 West of the 5th Principal Meridian, Cass County, North Dakota, described as follows:

Beginning at the northeast corner of said Northwest Quarter; thence South 01 degree 56 minutes 40 seconds East along the east line of said Northwest Quarter a distance of 439.68 feet; thence South 88 degrees 03 minutes 08 seconds West to a point on a line lying parallel with and 205.00 feet southeasterly, as measured at right angles, of the southeasterly line of AUSTIN'S SUBDIVISION, according to the recorded plat thereof; thence South 55 degrees 59 minutes 16 seconds West along said parallel line a distance of 2619.13 feet to a point on a line lying 200.00 feet east of and parallel with the west line of said Northwest Quarter; thence North 02 degrees 01 minute 05 seconds West along said parallel line a distance of 241.72 feet to a point on the southeasterly line of said AUSTIN'S SUBDIVISION; thence North 55 degrees 59 minutes 16 seconds East along the southeasterly line of said AUSTIN'S SUBDIVISION a distance of 2751.94 feet; thence northeasterly 151.99 feet along a tangential curve concave to the northwest having a radius of 150.00 feet along the southeasterly line of said AUSTIN'S SUBDIVISION to a point on the north line of said Northwest Quarter; thence North 87 degrees 55 minutes 49 seconds East along the north line of said Northwest Quarter a distance of 11.42 feet to the northeast corner thereof, the point of beginning.

The above described tract contains 13.72 acres, more or less and is subject to easements, reservations, restrictions, and rights-of-way of record, if any.

and,

That part of the Northwest Quarter of Section 4, Township 138 North, Range 49 West of the 5th Principal Meridian, Cass County, North Dakota described as follows:

Beginning at the most southerly corner of AUSTIN'S SUBDIVISION, according to the recorded plat thereof; thence North 55 degrees 59 minutes 16 seconds East along the southeasterly line of said AUSTIN'S SUBDIVISION a distance of 235.82 feet; thence South 02 degrees 01 minute 05 seconds East parallel with the west line of said Northwest Quarter a distance of 241.72 feet to a point on a line lying parallel with and 205.00 feet southeasterly, as measured at right angles, of the southeasterly line of said AUSTIN'S SUBDIVISION; thence South 55



degrees 59 minutes 16 seconds West along said parallel line a distance of 182.32 feet; thence southwesterly 55.68 feet along a tangential curve concave to the southeast having a radius of 470.00 feet to a point on the west line of said Northwest Quarter; thence North 02 degrees 01 minute 05 seconds West along the west line of said Northwest Quarter a distance of 245.60 feet to the most southerly corner of said AUSTIN'S SUBDIVISION, the point of beginning.

The above described tract contains 1.11 acres, more or less and is subject to easements, reservations, restrictions, and rights-of-way of record, if any.

Tract Two: The Southwest Quarter (SW $\frac{1}{4}$ ) of Section Four (4), Township One Hundred Thirty-eight (138) North, Range Forty-nine (49) West of the Fifth Principal Meridian, Cass County, North Dakota.

EXHIBIT B

FORM OF EASEMENT RELEASE

**EASEMENT RELEASE**

**THIS EASEMENT RELEASE** (the "Release") is made and executed as of the \_\_\_ day of \_\_\_\_\_, 20\_\_\_, by CITY OF FARGO, NORTH DAKOTA, a North Dakota municipal corporation ("City").

**RECITALS**

- A. Easement Holders obtained from Melvin O. Arneson, Vernon S. Arneson, Arnold T. Arneson, Gerhard H. Arneson and Gladys S. Arneson, an easement over certain real property, pursuant to an easement, dated May 16, 1983, and recorded in the office of the Cass County Register of Deeds, now Recorder, in Book "M-9", of Miscellaneous, at page 501 (the "Easement").
- B. City is a party to that certain Easement Release Agreement dated as of October 10, 2018, and recorded in the office of the Recorder for Cass county, North Dakota, on \_\_\_\_\_, 2018 as Doc. No. \_\_\_\_\_ (the "Release Agreement"). All capitalized terms used, but not separately defined herein, shall have the meanings ascribed them in the Release Agreement.
- C. OGPC, or its successors or assigns, has paid to City the Release Amount as pertains to the property described on Exhibit X (the "Release Property"), and City is executing this Release pertaining to the Release Property.

**RELEASE**

**NOW, THEREFORE**, in consideration of the Recitals, City, for itself and on behalf of the Easement Holders pursuant to the authority established under the Release Agreement, hereby fully, finally and forever releases the Release Property from the Easement, and the Easement Holders hereafter have no further right title or interest in and to the Release Property under or pursuant to the Easement.

*[the remainder of this page intentionally left blank – signature page follows]*

**IN WITNESS WHEREOF**, City has executed this Release as of the day and year first above written.

**CITY OF FARGO, NORTH DAKOTA**

By: \_\_\_\_\_  
Timothy J. Mahoney, Mayor

ATTEST:

\_\_\_\_\_  
Steve Sprague, City Auditor

STATE OF NORTH DAKOTA       )  
  ) SS  
COUNTY OF CASS                     )

On this\_\_ day of \_\_\_\_\_, 20\_\_, before me, a notary public in and for said state, personally appeared Timothy J. Mahoney and Steve Sprague, known to me to be the Mayor and City Auditor, respectively, of the City of Fargo, a North Dakota municipal corporation, described in and who executed the foregoing Release and acknowledged that they executed the same on behalf of the corporation, as the free act and deed of the municipal corporation.

\_\_\_\_\_  
Notary Public

EXHIBIT X  
RELEASE PROPERTY

(4)

IN THE DISTRICT COURT FOR CASS COUNTY, NORTH DAKOTA

James Peter Sabo,

Plaintiff,

vs.

Civil No. 09-2018-CV-03343

**Summons**

City of Fargo, a political subdivision  
of the State of North Dakota,

Defendant.

THE STATE OF NORTH DAKOTA TO THE ABOVE NAMED DEFENDANT:

You are hereby summoned and required to appear and defend against the Complaint in this action, which is herewith served upon you, by serving upon the undersigned an answer or other proper response within twenty-one days after the service of this Summons upon you, exclusive of the day of service. If you fail to do so, judgment by default will be taken against you for the relief demanded in the Complaint.

Dated this 3<sup>rd</sup> day of October, 2018.

GARAAS LAW FIRM

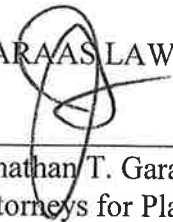
  
Jonathan T. Garaas  
Attorneys for Plaintiff  
Office and Post Office Address:  
DeMores Office Park  
1314 23rd Street South  
Fargo, North Dakota 58103  
garaaslawfirm@ideaone.net  
Telephone: (701) 293-7211  
North Dakota Bar ID # 03080

IN THE DISTRICT COURT FOR CASS COUNTY, NORTH DAKOTA

James Peter Sabo,

Plaintiff,

vs.

Civil No. 09-2018-CV-03343

**Complaint & Notice of Appeal**

City of Fargo, a political subdivision  
of the State of North Dakota,

Defendant.

[¶1] The Plaintiff James Peter Sabo complains and alleges:

[¶2] That the Plaintiff is a resident of the City of Fargo, Cass County, North Dakota, and also, Plaintiff is a citizen of the United States of America. As a citizen of the United States of America, Plaintiff James Peter Sabo [hereinafter "LANDOWNER"] has rights, privileges, or immunities secured by the Constitution and laws arising out of his ownership of real property, and no statute, ordinance, regulation, custom, or usage, of the State of North Dakota, or any of its political subdivisions, may wrongfully deprive him of those rights, privileges, or immunities.

[¶3] That Plaintiff James Peter Sabo is the owner of the following described tract of land located within Fargo, Cass County, North Dakota:

Lot 113, Belmont Park Addition to the City of Fargo, situate in the County of Cass and the State of North Dakota.

The common street address for said tract of land is 427 15<sup>th</sup> Avenue South, Fargo, North Dakota 58103.

[¶4] That Defendant City of Fargo [hereinafter “FARGO”] is a political subdivision authorized to exist under the laws of the state of North Dakota, and despite having a home rule charter, it has not enacted any ordinances, nor has it attempted to enact any ordinances that supersede state law with respect to any issue herein raised; FARGO is still subject to North Dakota’s statutory provisions with respect to ordering demolition of private buildings and exercise of eminent domain, along with the obligation to comply with the Constitution of North Dakota and/or the Constitution of the United States of America. See, Sauby v. City of Fargo, 2008 ND 60, ¶s 5-6, 747 N.W.2d 65, which specifically cites City of Fargo v. Malme, 2007 ND 137, ¶ 10, 737 N.W.2d 390, and City of Bismarck v. Fettig, 1999 ND 193, ¶ 4, 601 N.W.2d 247.

[¶5] Pursuant to an unrecorded contract for deed, LANDOWNER granted possession of the premises to another individual that initiated extensive, but unsuccessful remodeling efforts prior to 2017. When required contract for deed payments were not paid, LANDOWNER cancelled the contract for deed and re-acquired possession of the real property. LANDOWNER subsequently initiated a repair/remodeling process that included issuance of a City of Fargo Building Permit No. 20170039 on January 13, 2017 [Permit No. BL20170039; a copy of the Building Permit is attached, marked Exhibit A, and incorporated by reference], which entitled LANDOWNER to “(r)epair structural damage caused by previous work without permits. Add trusses to the front of the home for a new roofed area. All work to comply with all applicable requirements of the City of Fargo including the 2015 Fargo Building Code.” While repair work was not continuous, never was construction “suspended or abandoned at any time for 180 days after work is commenced.” On December 12, 2017, Fargo Building Inspector Joseph Girdner wrote LANDOWNER indicating

“Permit BL20170039 has been filed as incomplete. .. A new permit will be required to complete the project.” At no time had the repairs been “suspended or abandoned for a period of 180 days after the time the work is commenced” as required by IRC Code R105.5, the section cited with the letter, so the permit had not expired by law. A copy of the letter is attached hereto, marked Exhibit B, and incorporated by reference.

[¶6] Still, LANDOWNER honored the City of Fargo’s request for a new permit, and made application for a building permit to finish the work authorized by Permit BL20170039 on May 21, 2018. While the permit was issued for the same purposes, LANDOWNER was not provided a copy of Permit BL20180708 for reasons unknown. As part of the permit process, LANDOWNER had secured the services of Sandman Structural Engineers which resulted in the creation of a drawing dated May 24, 2018, for a “HOUSE BEAM”. A copy of the House Beam drawing dated May 24, 2018, is attached hereto, marked Exhibit C, and incorporated by reference. LANDOWNER also secured the services of various laborers that were engaged in making the repairs authorized by the newly issued Permit BL20180708 [and its predecessor, Permit BL20170039]. As part of those repairs, the brick facade on the front of the building had been removed, interior and exterior demolition had been initiated, and ultimately, the required steel beam had been ordered, and paid for by LANDOWNER, as hereafter identified.

[¶7] Without advance warning, and inconsistent with verbal advice previously given LANDOWNER by Fargo Building Inspector Joseph Girdner on or immediately before June 12, 2018, two (2) days later, on June 14, 2018, Bruce Taralson, Fargo’s Inspections Administrator, issued a “Finding and Determination of Substandard Building (&) Order to Vacate, Secure Building,



and Make Repairs (&) Notice of Right to Appeal”, a copy of which is attached hereto, marked Exhibit D, and incorporated by reference. The certified mailing was not received by LANDOWNER as evidenced by the last page in Exhibit D obtained from Fargo’s files; LANDOWNER does acknowledge that it was posted on the building. The document was issued in violation of law, as outlined hereafter, to include the illegal and previously unannounced act of Building Inspector Joseph Girdner dated June 12, 2018, in a “Conditions Found Statement” of said date which stated, “current permit, BL20180708, is hereby voided.” Such written document of June 12, 2018, directly conflicted with his verbal advice/permission personally given LANDOWNER allowing, and encouraging, the contemplated repairs then being done. The June 14, 2018, document contained an “**Order for repair**” which provided:

The undersigned building official has determined that the building must be repaired. Therefore, it is ordered that all required permits be secured for the appropriate repair of the building or structure. A new permit must be obtained within 30 days of this (June 14, 2018) letter.

[¶8] Still, LANDOWNER honored the June 14, 2018, order to secure the building, and, in an attempt to comply with the Order of June 14, 2018, which included the “Order for repair”, LANDOWNER applied for and received another Building Permit on June 25, 2018 [BL20180955]. Prior to the issuance of BL20180955 on June 25, 2018, LANDOWNER had worked with Fargo’s building inspector(s) to assure repairs to the real property could be accomplished with compliance of Fargo’s building codes, and LANDOWNER was repeatedly assured such repair/remodeling efforts would be acceptable.

[¶9] Without advance warning, and inconsistent with verbal advice previously given by Fargo Building Inspector Joseph Girdner on or immediately before June 25, 2018, later on the same date,

Bruce Taralson, Fargo's Inspections Administrator, issued a "Notice of Dangerous Building", a copy of which is attached hereto, marked Exhibit E, and incorporated by reference. The document was issued in violation of law, as outlined hereafter, to include (a) the irrelevant and immaterial findings of Robert E. Harshberger dated June 22, 2018, concerning "a cost to repair that exceeds the minimum fifty-percent" [see Exhibit F attached hereto and incorporated by reference], and (b) the illegal and previously unannounced act of Building Inspector Joseph Girdner dated June 12, 2018, in a "Conditions Found Statement" of said date which stated, "current permit, BL20180708, is hereby voided", plus additional new contradictory language "**Added June 25, 2018**" which first ordered that "**All existing conditions of building need to be exposed in order to be inspected to determine if the building is allowed to remain. This may include removing all existing interior finishes**", and then again voided the two (2) issued building permits: "Permits BL20180708 **and** **BL20180955 (added June 25, 2018)**, are hereby voided." In addition, the City of Fargo ordered LANDOWNER to take action:

The following actions must be taken:

- Provide engineering on structure, mechanical, plumbing and electrical.
- Provide structural plans, **floor plans and truss drawings (added June 25, 2018)**.
- Provide list of licensed trades with plans.
- Obtain a new permit and follow through will (sic) all necessary inspections.

The Inspections Administrator's letter of June 25, 2018, failed to identify any legal basis for requiring any of the mandates before issuance of a new permit, and none of the identified mandated components had been necessary for any prior building permit on the premises.

[¶10] LANDOWNER sought information so as to comply with the City of Fargo's laws, and expectations. Towards that objective, LANDOWNER had earlier secured the services of Sandman

Structural Engineers for the design of the “house beam” [see ¶ 6, above], with the adequacy of the existing slab to support the required house beam accomplished by Sandman Structural Engineers on June 20, 2018. Later, Sandman Structural Engineers was requested by LANDOWNER to review the property being remodeled to provide an opinion as areas needing attention in view of the required expectation for structural plans, floor plans and truss drawings. A copy of the July 5, 2018, report of Sandman Structural Engineers is attached hereto, marked Exhibit G, and incorporated by reference. On July 2, 2018, Wolf Steel Construction, Inc., supplied a quotation of \$2,769.00, plus tax, for a “Base Bid” for the materials for the house beam based upon the Sandman Structural drawings. A copy of the July 2, 2018, quotation from Wolf Steel Construction, Inc. [with attachments reduced in sized], and the July 26, 2018, Invoice marked “PAID 07/26/2018” is attached hereto, marked Exhibit H, and incorporated by reference. Meanwhile, representatives of the City of Fargo continued to assure LANDOWNER the repairs contemplated to occur would suffice, and the building, when repaired, would meet or exceed the City of Fargo’s existing building code.

[¶11] Despite verbal assurances of Fargo’s employees, agents, or representatives intended to deceive LANDOWNER – *with LANDOWNER always agreeing to do whatever was necessary to meet the City of Fargo’s building codes* – the City of Fargo embarked on a pattern of escalating demands so as to both deceive and delay LANDOWNER past time constraints imposed by the City of Fargo. On July 18, 2018, Building Inspector Joseph Girdner wrote LANDOWNER imposing new criteria which “must be met before a permit for 427 15 Avenue S. in Fargo can be issued.” A copy of the July 18, 2018, letter is attached hereto, marked Exhibit I, and incorporated by reference. The Building Inspector’s letter of July 18, 2018, failed to identify any legal basis for requiring any of the

six (6) mandates, and none of the six (6) identified mandated components had been necessary for any prior building permit on the premises.

[¶12] Unknown to LANDOWNER, the City of Fargo had decided that no repair(s) would be acceptable, even though repairs were ordered done – the structure must be demolished because “the building inspector for the City of Fargo has found the building, consisting of a multistory, wood-framed structure to be a Dangerous Building within the standards set forth in the Fargo Municipal Code, Article 21-04, Dangerous Buildings and IPMC Code 108.1.5 concerning Dangerous Structures”, and that, “the owner of the building must demolish the building within 30 (thirty) days from the date of this notice or obtain a permit to repair. To obtain a permit, see ‘Conditions Found Statement’ below.” The City of Fargo’s conditions constantly changed, making compliance by repair permit impossible for LANDOWNER to accomplish.

[¶13] LANDOWNER was made aware of North Dakota’s statutory requirements as set forth in N.D.C.C. § 40-05-02(23), which provides as follows [*emphasis added*]:

23. Substandard buildings or structures. *The governing body of any city shall have the authority to provide by ordinance for the demolition, repair, or removal of any building or structure located within the limits of such city or other territory under its jurisdiction, which creates a fire hazard, is dangerous to the safety of the occupants or persons frequenting such premises, or is permitted by the owner to remain in a dilapidated condition. Any such ordinance must provide for written notice to the owner of a hearing by the governing body before final action is taken by such body. It must also provide a reasonable time within which an appeal may be taken by the owner from any final order entered by such governing body to a court of competent jurisdiction.* The amount of the cost of any demolition, repair, or removal of a building or structure constitutes a lien against the real property from which the cost was incurred and the lien may be foreclosed in judicial proceedings in the manner provided by law for loans secured by liens on real property. If this amount is not adequate to cover the cost of demolition, repair, or removal, the city has a lien for the amount of the additional costs on all real property owned, or later acquired, by the owner in the city. If the city provides the amount of the lien and the

name of the owner, the county auditor shall enter on the tax list the amount of the additional cost as a tax lien. The tax lien is enforceable by the city in the same manner as a tax lien by a county. This subsection in no way limits or restricts any authority which is now or may hereafter be vested in the state fire marshal for the regulation or control of such buildings or structures.

LANDOWNER was aware that the statutory requirement – a jurisdictional prerequisite set by a North Dakota statute – had not occurred; LANDOWNER had not received any written notice of a hearing to be held by the governing body before final action is taken by such body. Moreover, LANDOWNER was aware that the City of Fargo’s ordinances had not been honored. Under Fargo Municipal Code Article 21-04 [a copy attached hereto, marked Exhibit J, and incorporated by reference], the Board of City Commissioners for Fargo, North Dakota, are compelled to “give written notice to the owner, occupant, mortgagee, lessee and all other persons having an interest in (a dangerous) building as shown by the records of the register of deeds of the county of Cass to appear before it on the date specified in the notice to show cause why the building or structure reported to be a ‘dangerous building’ should not be repaired, vacated, or demolished in accordance with the statement of particulars set forth in the building inspector(s) notice provided for herein in § 21-0404, subsection (E).” See, FMC § 21-0405(A). LANDOWNER had not received any written notice to show cause to appear at any hearing to be held by the governing body as required by law. LANDOWNER is now aware that the entire process utilized by the City of Fargo violates legal principles enunciated in Kelsch v. Jaeger, 2002 ND 53, ¶ 21, 641 N.W.2d 100, recently reaffirmed, and succinctly stated, in North Dakota Legislative Assembly v. Burgum, 2018 ND 189, ¶ 46, 916 N.W.2d 83:

[¶ 46] “Unless expressly authorized by the State Constitution, the Legislature may not delegate its purely legislative powers to any other body.” *County of Stutsman*, 371

N.W.2d at 327; *see also Kelsh*, 2002 ND 53, ¶ 23, 641 N.W.2d 100. The Legislative Assembly may not delegate to another body the power to make law—to legislate—but it may bestow authority to execute the laws it enacts. *Ralston Purina Co. v. Hagemeister*, 188 N.W.2d 405, 411 (N.D. 1971). The modern view of the non-delegation doctrine “recognizes that, in a complex area, it may be necessary and appropriate to delegate in broad and general terms, as long as there are adequate standards and procedural safeguards.” *North Dakota Council of School Administrators v. Sinner*, 458 N.W.2d 280, 285 (N.D. 1990) (rejecting non-delegation challenge to statutory budget allotment procedure). “The power to ascertain certain facts which will bring the provisions of a law into operation by its own terms is not an unconstitutional delegation of legislative powers.” *County of Stutsman*, at 327. “However, the law must set forth reasonably clear guidelines to enable the appropriate body to ascertain the facts.” *Id.*

In the context of these municipal ordinances, the Legislative Assembly may not delegate its authority to make laws for the demolition, repair, or removal of any building or structure located within the limits of Fargo, or other territory under its jurisdiction, which creates a fire hazard, is dangerous to the safety of the occupants or persons frequenting such premises, or is permitted by the owner to remain in a dilapidated condition, but if the North Dakota Legislative Assembly attempts so to do, it must also establish (a) “clear guidelines to enable the appropriate body to ascertain the facts” and (b) “adequate standards and procedural safeguards” – the Constitution does not specifically allow this exception with respect to dangerous buildings, and the North Dakota Legislative Assembly has failed to establish any guidelines, or procedural safeguards whatsoever. Hence, unconstitutional delegation by the North Dakota Legislative Assembly has occurred, and all of Fargo’s ordinances [FMC Article 21-04] are infirm or without authority. Additionally, the Legislative Assembly cannot delegate the authority to create a process for an appeal to be taken by the owner from any final order entered by such governing body to a court of competent jurisdiction. FMC § 21-0412 purports to provide for LANDOWNER to “appeal from such order to the district court of Cass County, North

Dakota”. It is well known that “(s)ubject matter jurisdiction cannot be conferred by agreement, consent, or waiver, and issues involving subject matter jurisdiction can be raised by the court at any time.” Harshberger v. Harshberger, 724 N.W.2d 148, ¶ 15, 724 N.W.2d 148, citing Trottier v. Bird, 2001 ND 177, ¶¶ 5–6, 635 N.W.2d 157. A district court judge’s jurisdiction is set by statute [N.D.C.C. § 27-05-06], and the City of Fargo may not pass any ordinance conferring jurisdiction upon such district court. See also, Article VI, § 8, Constitution of North Dakota. LANDOWNER has constitutionally protected property rights, and minimum procedural due process requirements will include the right of a meaningful hearing, and possibly, an appeal to a competent court of record. The fundamental requirement of due process is the opportunity to be heard “at a meaningful time and in a meaningful manner.” *Mathews v. Eldridge*, 424 U.S. 319, 333 (1976), citing *Armstrong v. Manzo*, 380 U.S. 545, 552, 85 S.Ct. 1187, 1191, 14 L.Ed.2d 62 (1965). The City of Fargo has no authority to confer jurisdiction upon the district court of Cass County, North Dakota; even the State of North Dakota’s own statute [N.D.C.C. § 40-05-02(23)] has determined that any municipality intending to accept the improper delegation of authority **must first create** an appropriate appeal process – which has not been done. The City of Fargo is without statutory authority to proceed for three (3) primary reasons: (1) the Legislative Assembly may not delegate its purely legislative powers to any other body; (2) if North Dakota’s Legislative Assembly does have such authority to delegate, it must first create/establish (a) “clear guidelines to enable the appropriate body to ascertain the facts” and (b) “adequate standards and procedural safeguards” [neither of which have occurred]; and in this case, (3) the attempted delegation was limited as to scope, and always required first the creation of a legal appeal process. Moreover, never can it be utilized to take LANDOWNER’S real property without Due Process of Law, in this case requiring first “just compensation” under

principles of eminent domain fixed by constitutions [North Dakota Constitution, Article I, § 16; United States Constitution, Fifth & Fourteenth Amendments] and statutes [N.D.C.C. Chapter 32-15].

[¶14] Against said background, LANDOWNER was made aware that a discussion at the Fargo City Commission concerning his real property would occur on Monday, August 13, 2018, and he attended without legal counsel because he was aware that North Dakota law, as well as Fargo's own municipal code, always required constitutionally protected Due Process of Law with mandatory prior written notice by statute and ordinance [certified mail is required by FMC § 21-0408 along with posting in a conspicuous place] – neither notice or service existed, nor had service even been attempted. The proceedings of Monday, August 13, 2018, were outrageous for reasons hereinafter advanced, to include LANDOWNER not being allowed to address the City Commissioners or introduce documents supporting his position, and also, his neighbors being allowed to vent anger, some which should have been addressed to remedial actions taken by the City of Fargo's employees or independent contractors, among many things. Totally irrelevant circumstances charged the discussion, some things going back decades. No meaningful hearing had been noticed, nor was such accomplished.

[¶15] So as to protect LANDOWNER'S civil rights and property rights, a letter dated August 17, 2018, signed by the Jonathan T. Garaas of the Garaas Law Firm, acting on behalf of LANDOWNER, was served upon the Fargo City Commission by mail. A copy of the letter dated August 17, 2018, is attached hereto, marked Exhibit K, and incorporated by reference.

[¶16] The Fargo City Commission failed to address the concerns expressed by LANDOWNER in the August 17, 2018, letter [Exhibit K], and instead the Fargo City Attorney attempted to justify non-compliance with Due Process of Law fixed within North Dakota's statutory law and Fargo's



municipal ordinances after acknowledging “Mr. Sabo was not delivered by certified mail, a written notice of the August 13<sup>th</sup> hearing nor was such notice posted at the subject property.” Indeed, Fargo’s City Attorney acted in violation of Due Process of Law fixed within North Dakota’s statutory law and Fargo’s municipal ordinances by (a) “stuffing the record”, and (b) failing to provide the mandatory prior written notice by certified mail. The nature and extent of the City Attorney’s violation of Due Process of Law are hereafter set forth in more detail.

[¶17] On Monday, September 10, 2018, item #30 of the agenda for the Fargo City Commission related to “Communication from City Attorney Erik Johnson regarding the Dangerous Building Proceedings at 427 15<sup>th</sup> Avenue South.” LANDOWNER and his counsel attended the Fargo City Commission meeting only to learn that the Fargo City Commission acts without regard to Due Process of Law. The nature and extent of the Fargo City Commission’s violations of Due Process of Law are hereafter set forth in more detail.

[¶18] Findings of Fact and Order of the Board of City Commissioners of the City of Fargo dated September 10, 2018, were served upon LANDOWNER on September 15, 2018. A copy of the document and claimed service documents are attached hereto, marked Exhibit L, and incorporated by reference; the Findings of Fact and Order are invalid for the reasons hereinafter advanced.

[¶19] The actions of the City of Fargo, its commissioners, employees, agents, and representatives have resulted in a substantial interference with LANDOWNER’S use and enjoyment of his land amounting to a taking of an interest in LANDOWNER’S property without first receiving just compensation in violation of the Fifth Amendment to the United States Constitution [made applicable to the states through the Fourteenth Amendment; Ripley v. City of Lincoln, 330 N.W.2d

505, 507 n. 1 (N.D. 1983), as cited in Wild Rice River Estates, Inc., v. City of Fargo, 2005 ND 193, ¶ 12, 705 N.W.2d 850] and Article I, Section 16, of the Constitution of North Dakota.

[¶20] The sum claimed by LANDOWNER as a just compensation for the taking of the interest in LANDOWNER’S real property is One Hundred Fifty-six Thousand and no/100th (\$156,000.00) Dollars, plus such other amount as necessary to ensure LANDOWNER is fully compensated by proper award of attorney fees, costs, and disbursements.

[¶21] The actions of the City of Fargo acting through its building inspections department, and ultimately by action(s) of the Fargo City Commission in taking away and/or refusing to issue appropriate building permits is without authority [violation of Due Process Clause in two (2) constitutions] because it also violates the Equal Protection Clause of the Fourteenth Amendment to the United States Constitution and Article I, Section 21, of the Constitution of North Dakota.

[¶22] The City of Fargo, acting through its commissioners, employees, agents, and representatives, have acted adversely to the civil rights and property rights of LANDOWNER in the following ways, among many:

<b>Date (approximate)</b>	<b>Description of wrongful action</b>	<b>Legal Basis for Position</b>
5/1/18 to date	Acting without proper delegation of legislative function	See ¶ 13 above
5/1/18 to date	Failure to provide “written notice to the owner of a hearing by the governing body before final action is taken by such body.”	N.D.C.C. § 40-05-02(23)

<b>Date (approximate)</b>	<b>Description of wrongful action</b>	<b>Legal Basis for Position</b>
5/1/18 to date	Failure to recognize that N.D.C.C. § 40-05-02(23) only allows for demolition, repair, or removal of buildings or structures which (1) “creates a fire hazard”, (2) “is dangerous to the safety of the occupants or persons frequenting such premises”, or (3) “is permitted by the owner to remain in a dilapidated condition.”	N.D.C.C. § 40-05-02(23)
5/1/18 to date	Failure to provide a reasonable time within which an appeal may be taken by the owner from any final order entered by such governing body to a court of competent jurisdiction.”	N.D.C.C. § 40-05-02(23)
5/1/18 to 6/14/18	Failure of the building inspector to notify LANDOWNER in writing, and then allow LANDOWNER a reasonable time “as may be necessary to do, or have done, the work or act required by the notice provided for (in FMC § 21-0404(D)).” The notice given on 6/14/18 did not identify the code violations requiring LANDOWNER’S repair – the building inspector’s notice was constitutionally deficient; LANDOWNER was always prepared to do whatever was required to make the structure compliant with applicable governmental standards fixed by law.	FMC § 21-0404(D)
5/1/18 to 6/14/18	Failure of the building inspector to honor the notice requirements of FMC § 21-0404(D) & (E). The notice never identified the “particulars” which made the building or structure a “dangerous building” – the building inspector would have been required to identify the specific code violation needing repair, not the vague and imprecise allegation of “Many and various code violations”, or similar imprecise assertions without citation to actual violation.	FMC § 21-0404(D) & (E)

Date (approximate)	Description of wrongful action	Legal Basis for Position
5/1/18 to 6/14/18	Failure of the building inspector to allow required repairs under FMC § 21-0404(E). The process of voiding the building permit while simultaneously ordering repairs acts to place LANDOWNER into legal limbo – an impossible place where any action or inaction results in him ignoring and honoring conflicting laws – LANDOWNER was placed in an impossible legal dilemma [or possibly, the veritable Hobson’s choice with the modern term meaning “an illusion of choice”]. To repair without a permit may be a crime; to not repair is to violate the order which may be a crime.	FMC § 21-0404(D) & (E)  Penalty set forth in FMC § 21-0406: “guilty of a misdemeanor and upon conviction thereof shall be fined not exceeding \$100 for each offense and every day subsequent to such notice in which the said owner shall fail to comply with any notice or order as above stated shall be deemed a separate offense.”
5/1/18 to 6/14/18	Failure of the building inspector to comply with the required posting of a notice of all “dangerous buildings” reading with language specified within the ordinance.	FMC § 21-0404(H)
6/25/18 to date	No written notice of the hearing of August 13, 2018	N.D.C.C. § 40-05-02(23) FMC § 21-0405(1) FMC § 21-0408 requires “certified mail” & “posted in a conspicuous place on the ‘dangerous building’ to which it relates.”
6/25/18 to date	Failure of the City Commissioners to insist upon a report of the building inspector under FMC § 21-0404(F) [with a “statement of particulars set forth in the building inspector(s) notice provided for herein in § 21-0404, subsection (E)”, followed by creation of an “notice to show cause”].	FMC § 21-0405(A)

Date (approximate)	Description of wrongful action	Legal Basis for Position
6/25/18 to date	Failure of the City Commissioners to hold a hearing following “notice to show cause”, and also limited to the individuals specified in the ordinance. Failure to honor Due Process of Law principles, to include rejection of comments and documents from LANDOWNER.	FMC § 21-0405(B) Due Process of Law - State & Federal
8/13/18 to date	Failure of the City Commissioners to make “written findings of fact from the testimony offered” as to “whether or not the building in question is a ‘dangerous building’ within the terms of § 21-0401.” Also, the terms of FMC § 21-0401 contain definitions for dangerous buildings in excess of those standards fixed by N.D.C.C. § 40-05-02(23), so Fargo exceeds its jurisdiction.	FMC § 21-0405(B) & (C) N.D.C.C. § 40-05-02(23)
8/13/18 to date	Failure of the City Commissioners to issue an order required by ordinance based upon its findings of fact required to be issued under FMC § 21-0405(D) which, if the ordinance-required order be issued, would be unconstitutional as a denial of equal protection of the laws – a LANDOWNER is treated differently than any other person having an interest in the building; other persons may “vacat(e) or repair() said ‘dangerous building’”, but the owner may not.	FMC § 21-0405(D) Equal Protection Clause - State & Federal
6/25/18 to date	No written notice of the hearing of September 10, 2018	N.D.C.C. § 40-05-02(23) FMC § 21-0405(1) FMC § 21-0408 requires “certified mail” & “posted in a conspicuous place on the ‘dangerous building’ to which it relates.”

Date (approximate)	Description of wrongful action	Legal Basis for Position
9/10/18 to date	Failure of the City Commissioners to hold a hearing following “notice to show cause”, and also limited to the individuals specified in the ordinance. Failure to honor Due Process of Law principles, to include rejection of comments from LANDOWNER, comments of his counsel, and inclusion of documents intended to “stuff the record” with documents claimed relevant by Fargo’s City Attorney, but irrelevant to any issues relating to identification of a dangerous building, and necessary remedial steps.	FMC § 21-0405(B) Due Process of Law - State & Federal
9/10/18 to date	Failure of the City Commissioners to make “written findings of fact from the testimony offered” as to “whether or not the building in question is a ‘dangerous building’ within the terms of § 21-0401.” Also, the terms of FMC § 21-0401 contain definitions for dangerous buildings in excess of those standards fixed by N.D.C.C. § 40-05-02(23), so Fargo exceeds its jurisdiction.	FMC § 21-0405(B) & (C) N.D.C.C. § 40-05-02(23)
9/10/18 to date	Failure of the City Commissioners to issue an order required by ordinance based upon its findings of fact required to be issued under FMC § 21-0405(D) which, if the ordinance-required order be issued, would be unconstitutional as a denial of equal protection of the laws – a LANDOWNER is treated differently than any other person having an interest in the building; other persons may “vacat(e) or repair() said ‘dangerous building’”, but the owner may not.	FMC § 21-0405(D) Equal Protection Clause - State & Federal
8/13/18 & 9/10/18	Failure to honor the standards for repair, vacation, or demolition that first requires an order for repair if a “dangerous building” can “reasonably be repaired so that it will no longer exist in violation of the terms of (Article 21-04)”	FMC § 21-0402(A) FMC § 21-0405(E)

<b>Date (approximate)</b>	<b>Description of wrongful action</b>	<b>Legal Basis for Position</b>
8/13/18 & 9/10/18	Failure to honor state law with respect to “dangerous buildings”, and also, wrongfully applying an inapplicable standard set forth in FMC § 21-0402(B) applicable only to (a) “dangerous buildings” which are “50% damaged, decayed, or deteriorated from its original value or structure”, or (b) “cases where a building cannot be repaired so that it will not longer be in violation of the terms of (Article 21-04)”. There was no evidence of the “original value” [so no evidence can exist to meet the percentage standard], and there was no evidence of any damage percentage, most of which results from the remodeling/repair process when building permits always existed. The structure was always capable of being repaired to meet Fargo’s building code standards.	FMC § 21-0402(C)
5/1/18 to date	Creating a definition of “dangerous buildings” that is arbitrary, capricious, or unreasonable. The definition of “dangerous building” includes every building that “exist(s) in violation of the Building Code, zoning ordinance, any provision of the Fire Prevention Code or other ordinances of this city” – if the distances between electrical outlets on a wall was in excess of the standard (or any other similar construction standard), no “reasonable” person would call that structure a “dangerous building” which must be demolished. Similarly, when the exterior panels of the Radisson in downtown Fargo became loose, falling to the ground, why was not the 18 story Radisson ordered demolished under the standard set in FMC § 21-0401(8)?	FMC § 21-0401(1-10) & FMC § 21-0403 Equal Protection Clause - Federal and State

<b>Date (approximate)</b>	<b>Description of wrongful action</b>	<b>Legal Basis for Position</b>
9/10/18	Acting contrary to law when asserting the building inspector had the right, and actually did make a finding that “the building, consisting of a multistory, wood-framed structure to be a dangerous building within the standards set forth in Article 21-04 of the Fargo Municipal Code and Section 108 of the International Property Maintenance Code concerning dangerous structures.” Finding of Fact #3.	If any of these municipal ordinances are valid, the City Commissioners are required to make such determination after hearing comporting with Due Process of Law; delegation of authority to the building inspector violates Due Process of Law.
9/10/18	Acting contrary to law when asserting the deputy assessor has the right to make a determination that the “estimated cost to repair the property would exceed fifty percent (50%) of the building value as established by the Fargo Assessment Department.” Finding of Fact #4.	If any of these municipal ordinances are valid, such determination is irrelevant to the ordinances; no ordinance allows for such determination, nor is there any relevance to determinations by anyone other than the person choosing to embark upon the repair/remodeling process. It is also preposterous – any inspection after demolition has commenced should cause the building’s value to decrease. Should we assume any major remodeling project, with permit, must commence and conclude in 30 days (before the city assessor can enter) so as to avoid the possibility of Fargo-ordered demolition based upon reduced value?



<b>Date (approximate)</b>	<b>Description of wrongful action</b>	<b>Legal Basis for Position</b>
9/10/18	Acting contrary to law and available facts when parroting Finding of Fact #5.	The building was fully repairable to meet all of Fargo's building codes, and Fargo's representatives stopped all repair work by voiding two (2) building permits, and then refusing to issue building permits with escalating demands as to effort and expense in violation of Equal Protection of Law and Due Process of Law.
9/10/18	Acting contrary to law and fact when asserting the findings set forth in Finding of Fact #6.	The legal standards set forth do not equate with the limited delegation of the North Dakota Legislative Assembly, and are preposterous standards during repair/remodeling processes. If such standards are followed, any structure undergoing remodeling/repair would be a "dangerous building" as soon as the water gets shut off, or the electrical service is disconnected. Arbitrary, capricious, and unreasonable come quick to mind, along with "there is no such law"!

<b>Date (approximate)</b>	<b>Description of wrongful action</b>	<b>Legal Basis for Position</b>
9/10/18	Acting contrary to law and fact when asserting the findings set forth in Finding of Fact #7 and Finding of Fact #8.	The information in the files of the Inspection Department and City Assessor's office need to be provided in legal proceedings; the finding is unsupported by fact or law if the proceedings are even legal.
9/10/18	Acting contrary to law and fact when asserting the findings set forth in Finding of Fact #9.	FMC § 21-0404 provides for specific language that does not appear in the posted sign.
9/10/18	Acting contrary to law and fact when asserting the findings set forth in Finding of Fact #10.	FMC § 21-0404(D) & (E) provides for specific information that was not included in the mailed notice, and simultaneously the building inspector voided the building permits, and engaged in escalating expectations making repairs impossible.

Date (approximate)	Description of wrongful action	Legal Basis for Position
9/10/18	Acting contrary to law and fact when asserting the findings set forth in Finding of Fact #11 and Finding of Fact #12 and Finding of Fact #13.	There has never been the required hearing meeting Due Process of Law requirements; however, LANDOWNER has provided proof that the repairs can be made so that no dangerous building would exist. See also, attached Exhibit M which is a letter from Kurt Sandman, of Sandman Structural Engineers dated September 7, 2018, indicating the “building will be of safe occupation” upon completion of the work “completed in accordance with the normal standard of care of the industry and inspected.”
9/10/18	LANDOWNER admits that Finding of Fact # 14 and Finding of Fact #15 are essentially true, but the City of Fargo errs in believing that jurisdictional elements can be waived or excused - prejudice abounds.	Due Process of Law Equal Protection of Law Improper delegation with unconstitutional proceedings
9/10/18	Order is invalid for all reasons advanced; failure to provide for an evidentiary hearing to ascertain if the order was complied within the designated time.	Due Process of Law Equal Protection of Law Improper delegation with unconstitutional proceedings

[¶23] That this pleading has been created for multiple purposes, to include the following:

A. The State of North Dakota has attempted to delegate legislative function to the City of Fargo, but such was contingent upon the City of Fargo providing a reasonable time within which an appeal may be taken by the owner from any final order entered by such governing body to a court

of competent jurisdiction [N.D.C.C. § 40-05-02(23)]. The City of Fargo has determined the appeal is to the district court for Cass County, North Dakota, but the City of Fargo does not have the authority to confer jurisdiction upon any district court in the State of North Dakota, nor has the North Dakota Legislative Assembly “provided by statute” for any such appeal as allowed by N.D.C.C. § 28-34-01. This pleading is intended as an appeal, the existence of an appeal being a condition precedent to any lawful exercise of authority by the City of Fargo under N.D.C.C. § 40-05-02(23), if there can be a delegation of legislative function under specific circumstances [and despite the lack of legislatively-enacted “clear guidelines”, “adequate standards”, or “procedural safeguards”].

B. A court of record within its jurisdiction has the power to declare rights, status, and other legal relations whether or not further relief is or could be claimed under N.D.C.C. § 32-23-01, and in accordance with the provisions of N.D.C.C. Chap. 32-23 entitled “Declaratory Judgments”. LANDOWNER invites the District Court issue such orders to declare LANDOWNER’S rights, status, and also, civil rights and property rights, to be superior to the City of Fargo so that Fargo will not violate LANDOWNER’S constitutionally and statutorily protected rights, and the property be fully restored to him so that necessary repairs can be completed. See specifically, N.D.C.C. § 32-23-02. This action is brought for the purpose of determining questions in actual controversy between the parties, and to preserve all civil rights and property rights possessed by LANDOWNER so as to avoid further economic harm. It would be the expectation of the LANDOWNER that N.D.C.C. § 40-05-02(23) and the City of Fargo’s ordinances, and the underlying municipal proceedings, be judicially determined to be unconstitutional predicated upon many principles of law, to include, but not limited to, (1) improper delegation of legislative function; (2) violation of the Due Process Clause - Federal and State; (3) violation of the Equal Protection of the laws - Federal and State; and

(4) violation of Eminent Domain principles, and statutes for proper exercise in taking private property - Federal and State. Pursuant to the statutory duty imposed upon LANDOWNER by N.D.C.C. § 32-23-11 because the North Dakota statute [N.D.C.C. § 40-05-02(23)] , and the resulting municipal ordinances [FMC Article 21-04] are alleged to be unconstitutional, the Attorney General of the State of North Dakota will be served a copy of this pleading, and is entitled to be heard.

C. Pursuant to N.D.C.C. § 32-23-08 allowing for supplemental relief, and also, 42 U.S.C. § 1983 providing for civil actions by the injured party against every person who, under color of any statute, ordinance, regulation, custom, or usage, of any State or Territory or the District of Columbia, subjects, or causes to be subjected, any citizen of the United States or other person within the jurisdiction thereof to the deprivation of any rights, privileges, or immunities secured by the Constitution and laws [see also, 42 U.S.C. § 1982 relating to property rights], LANDOWNER seeks relief, to include a reasonable attorney's fee as part of the costs as allowed by 42 U.S.C. § 1988(b), or other applicable statutes.

[¶24] WHEREFORE, Plaintiff James Peter Sabo prays for judgment:

[¶25] 1. That Plaintiff James Peter Sabo's real property be restored to him free from illegal governmental interference so that necessary repairs can be completed;

[¶26] 2. Pursuant to N.D.C.C. Chap. 32-23 entitled "Declaratory Judgments", that the District Court issue appropriate orders declaring LANDOWNER'S rights, status, and also, civil rights and property rights, to be superior to the City of Fargo;

[¶27] 3. That N.D.C.C. § 40-05-02(23) and the City of Fargo's ordinances [FMC Article 21-04], and the underlying municipal proceedings, be judicially determined to be unconstitutional predicated upon many principles of law, to include, but not limited

to, (1) improper delegation of legislative function; (2) violation of the Due Process Clause - Federal and State; (3) violation of the Equal Protection of the laws - Federal and State; and (4) violation of Eminent Domain principles, and statutes for proper exercise in taking private property - Federal and State.

[¶28] 4. Pursuant to 42 U.S.C. § 1983 providing for civil actions by the injured party against every person who, under color of any statute, ordinance, regulation, custom, or usage, of any State or Territory or the District of Columbia, subjects, or causes to be subjected, any citizen of the United States or other person within the jurisdiction thereof to the deprivation of any rights, privileges, or immunities secured by the Constitution and laws [see also, 42 U.S.C. § 1982 relating to property rights], LANDOWNER seeks damages in the minimum amount of \$156,000.00, and also, a reasonable attorney's fee as part of the costs as allowed by 42 U.S.C. § 1988(b), or other applicable statutes.

[¶29] 5. If the court has the right to consider this as an appeal, then Plaintiff requests that all orders issued by the City of Fargo, or any department thereof, be vacated or overturned so that Plaintiff may accomplish the remodeling/repair of his real property.

[¶30] 6. That the Plaintiff have such other and further relief as is just and equitable.

Dated this 3<sup>rd</sup> day of October, 2018.

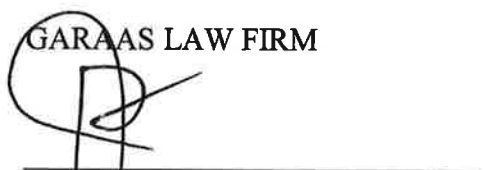

GARAAS LAW FIRM

---

Jonathan T. Garaas  
Attorneys for Plaintiff  
Office and Post Office Address:  
DeMores Office Park  
1314 23rd Street South  
Fargo, North Dakota 58103  
E-mail address: garaaslawfirm@ideaone.net  
Telephone: (701) 293-7211  
North Dakota Bar ID #03080

CITY OF FARGO  
FARGO, NORTH DAKOTA  
**BUILDING PERMIT**

DATE 1/13/2017  
PERMIT NO. BL20170039

SPECIAL FLOOD HAZARD  FLOOD PROTECTION ELEVATION \_\_\_\_\_

SPECIAL FLOOD HAZARD PERMITS SHALL BE CONSTRUCTED IN ACCORDANCE TO THE FLOOD PROOFING CODE OF THE CITY OF FARGO.

PERMIT ADDRESS 427 15 AVE S

ADDITION 0120

LEGAL DESCRIPTION  
LOT 113 ADDN# 0120 (Belmont Park)

TOWNSHIP \_\_\_\_\_

OWNER SABO, JAMES PETER PHONE \_\_\_\_\_ VENDOR C100 LICENSE# CASH  
CONTRACTOR CASH SALE  
ADDITIONAL CONTRACTORS Pete 237-6231

ARCHITECT OR DESIGNER \_\_\_\_\_ CONTACT \_\_\_\_\_  
WORK CLASS IRR

DESCRIPTION OF WORK  
Repair structural damage caused by previous work without permits. Add trusses to the front of the home for a new roofed area. All work to comply with all applicable requirements of the City of Fargo including the 2015 Fargo Building Code.

VALUATION \$20,000.00 PLAN FEE \$0.00 PERMIT FEE \$126.20 TOTAL FEE \$126.20  
INVESTIGATION FEE \$0.00

BLDG. SQ. FT. \_\_\_\_\_ HEIGHT \_\_\_\_\_ NUMBER OF STORIES \_\_\_\_\_ OCCUP. GROUP R-3  
WIDTH \_\_\_\_\_ DEPTH \_\_\_\_\_ NUMBER OF UNITS \_\_\_\_\_ OCCUP. LOAD \_\_\_\_\_

TREATED PLATES Required FOUNDATION Existing TYPE CONSTRUCTION VB  
SMOKE DETECTORS Required ROOF Asphalt  
WINDOW AREA Egress HEATING Existing  
EXITS REQUIRED 1 BASEMENT \_\_\_\_\_  
FIRE SPRINKLERS \_\_\_\_\_ FIREPLACES \_\_\_\_\_

ZONE SR-3 LOT SIZE 5000.00  
FRONT YARD 20 SIDE YARD 10/10 REAR YARD 15 STREET \_\_\_\_\_ MAX. LOT COVER 35  
Lot Width Front 40 Lot Depth1 \_\_\_\_\_  
Lot Width Back \_\_\_\_\_ Lot Depth2 125

NOTICE  
SEPARATE PERMITS ARE REQUIRED FOR ELECTRICAL, PLUMBING, HEATING, AIR CONDITIONING, PARKING LOTS AND SIGNS.

**PLEASE BE SURE TO READ THE DISCLAIMER ON THE REVERSE SIDE OF THIS PERMIT.**

Signature of Contractor or Authorized Agent \_\_\_\_\_ Date \_\_\_\_\_  
Signature of Owner (If owner builder) [Signature] Date 1-13-17  
Signature of Issuer \_\_\_\_\_ Date \_\_\_\_\_

**EXHIBIT A**



DATE 1/13/2017

PERMIT NO. **BL20170039**

\*\*\*Note: This permit becomes void if construction is not begun within 180 days or is suspended or abandoned at any time for 180 days after work is commenced.

**Building Permit Acknowledgments**

1. I understand and certify that issuance or granting of a permit shall not be construed to be a permit for, or an approval of, any violation of any of the provisions of this code or of any other ordinance of the jurisdiction. Permits presuming to give authority to violate or cancel the provisions of this code or other ordinances of the jurisdiction shall not be valid. The issuance of a permit based on construction documents and other data shall not prevent the building official from requiring the correction of errors in the construction, in the construction documents and other data. The building official is also authorized to prevent occupancy or use of a structure where in violation of this code or of any other ordinances of this jurisdiction exist.
2. Through application for and acceptance of this building permit the permit applicant/holder/owner understands and agrees that the City will conduct periodic observations of construction, but that such observation or review of plans and/or construction does not constitute either explicit or implied certification that the plans and/or construction comply with City Codes or any other applicable requirements. The permit applicant/holder/owner at all times remains responsible for ensuring that the construction, plans, and specifications comply with all requirements of all City Codes and other applicable requirements. The City will not provide continuous on-site observation of construction, and disclaims any responsibility for defects in materials or workmanship.
3. The City encourages and recommends the permit applicant/holder/owner hire a private, on-site inspector or other professional as the applicant/holder/owner deems necessary in order to ensure that all aspects of the plans and/or construction comply with applicable codes and all other requirements.

**AS PERMIT APPLICANT, I ACKNOWLEDGE THAT I HAVE BEEN MADE AWARE OF THE ABOVE STATEMENTS AND CONDITIONS.**

APPLICANT INITIALS: \_\_\_\_\_ DATE: \_\_\_\_\_

**AS BUILDING OFFICIAL, I ACKNOWLEDGE THAT I HAVE MADE THE PERMIT APPLICANT AWARE OF THE ABOVE STATEMENTS AND CONDITIONS.**

BUILDING OFFICIAL INITIALS:  DATE: 1-13-2017



**INSPECTIONS**

200 3RD STREET NORTH  
FARGO, NORTH DAKOTA 58102  
PHONE: 701-241-1561  
FAX: 701-476-6779

**Expired Permit Notice**

December 12, 2017

James Peter Sabo  
1221 9 Ave N  
Fargo ND 58102

RE: 427 15 Ave S./ Permit # 20170039

We issued you a permit on January 13 2017 that is not completed or has not received any of the required building inspections. It is the responsibility of the permit applicant to arrange for all required inspections.

IRC Code R105.5 EXPIRATION. Every permit issued shall become invalid unless the work authorized by such permit is commenced within 180 days after its issuance, or if the work authorized by such permit is suspended or abandoned for a period of 180 days after the time the work is commenced.

Permit BL20170039 has been filed as incomplete. This may affect insurance rates and future deed transfers. A new permit will be required to complete the project. Please contact the Fargo Building Inspections Department with any question you may have.

Thank you,

Joseph Girdner  
Fargo Building Inspector

→ Kurt Sandman

Pete Sabo 701 237 6231 704 729 6231



PROJ. #	DATE	BY	PAGE
	5.24.18	KS	
HOUSE BEAM			
PETE SABO 427 15TH AVE S			

FLR LOADS

LIVE LOAD = 40 PSF  
 DEAD LOAD = 20 PSF

Ⓟ FIRST FLOOR LOADS ONLY  
 UPPER LEVEL CLEAR SPANS

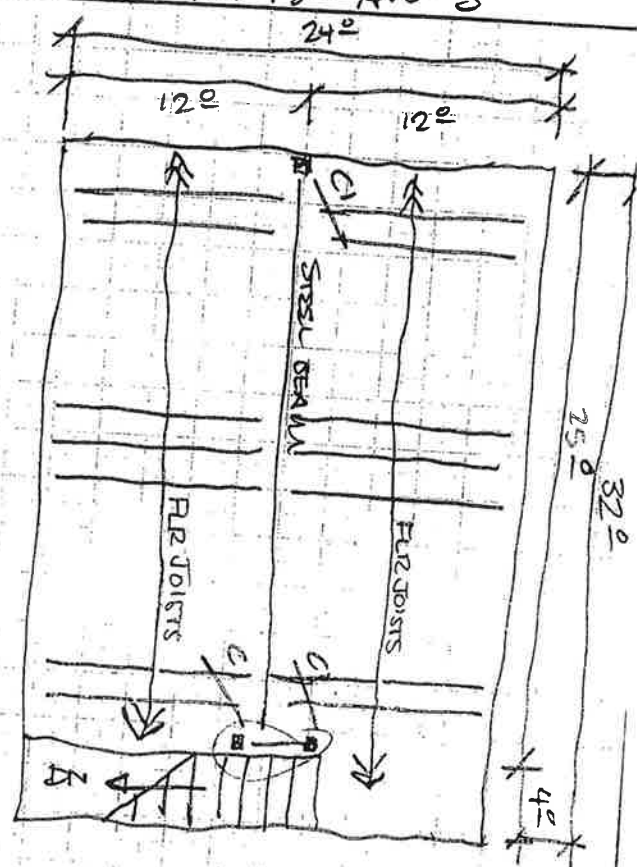

BEAM DESIGN

$$W_1 = 40 \text{ PSF} (12) = .48 \text{ k/ft U}$$

$$20 \text{ PSF} (12) = .24 \text{ k/ft DL}$$

$$R_u = 9.4 \text{ k}$$

**EXHIBIT C**

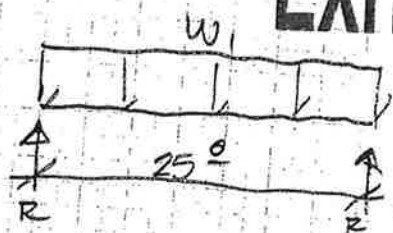

→ USE **W12X26**  $U = .63$   $\delta = 1.13"$   $4/269$   
**W14X22**  $U = .70$   $\delta = 1.14"$   $4/264$

\* PUNCH HOLES IN TOP FLANGE FOR WOOD PLATES

COLUMN DESIGN

$l = 8'$   $P = 9.4 \text{ k}$

USE **C1** **HSS 3X3X3/16**  $P_{all} = 28.5 \text{ k}$   $OK$   
 • 1/2" CAP PL W/ (2) - 5/8 BOLTS  
 • 1/2" X 3X8 BASE PL W/ (4) - 5/8 EXP BOLTS

FOOTING DESIGN

$P = 9.4 \text{ k}$   
 $A_f = \frac{9400 \text{ lbs}}{1500 \text{ PSF}} \approx 6.3 \text{ SF}$

ONE END BEARS ON FDN WALL W/ CORBELING WILL ENGAGE 10.5 SF OR FTG - OK.  
 THE OTHER END WILL HAVE TRANSFER BEAM 12 POSTS SO LOAD @ EACH POST IS 4.7k, 4" c/c



**SANDMAN**  
Structural Engineers

PROJ. #

DATE

BY

PAGE

*Petc*

*701-729-62*

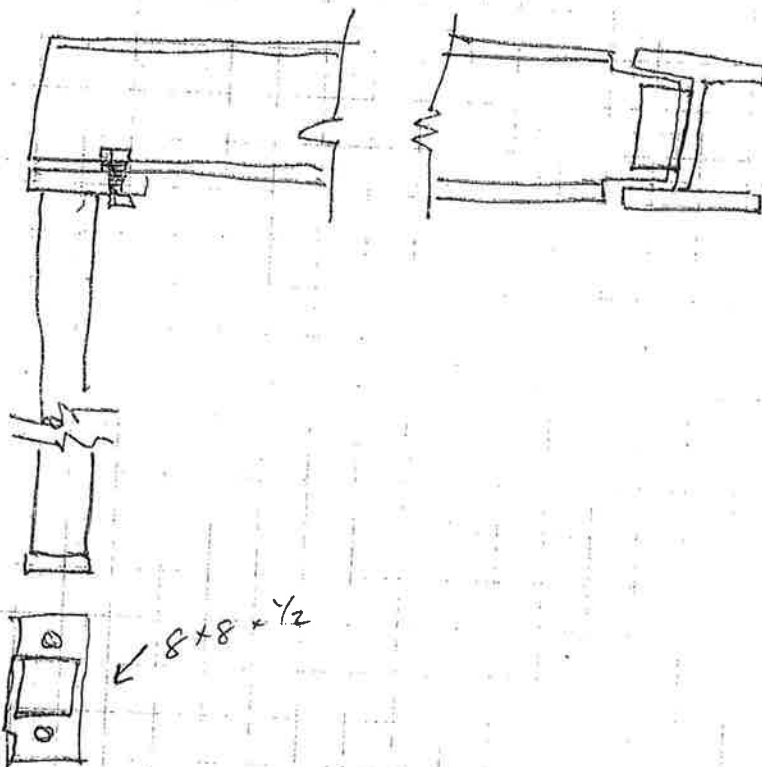

# Fargo Inspections

City of Fargo  
200 Third Street North  
701-241-1561  
701-476-6779 fax



---

---

**FINDING AND DETERMINATION OF SUBSTANDARD BUILDING  
ORDER TO VACATE, SECURE BUILDING, AND MAKE REPAIRS  
NOTICE OF RIGHT TO APPEAL**

---

---

<b>DATE:</b>	June 14, 2018
<b>ADDRESS AND/OR LEGAL DESCRIPTION OF SUBJECT PROPERTY:</b>	427 15 Avenue S., Fargo, ND 58103 Lot 113 ADDN# 0120 (Belmont Park)
<b>NAME OF PROPERTY OWNER: ADDRESS OF PROPERTY OWNER:</b>	James Peter Sabo 1221 9 Avenue N. Fargo, ND 58102
<b>NAMES AND ADDRESSES OF MORTGAGE HOLDERS, LIENHOLDERS ET CETERA AND LESSEES OF RECORD:</b>	N/A
<b>NAME OF INSPECTOR:</b>	Joseph Girdner, Building Inspector

---

---

**Finding of substandard building.** The undersigned building official has determined the above-described subject property to be a substandard building, as is defined by the International Property Maintenance Code 2015 edition, as adopted by reference in the Fargo Municipal Code at section 31-0101. Specifically, the violations of said housing code have been identified and are described more fully in the conditions found statement of the Inspection Division, a copy of which is attached hereto and incorporated herein as if fully set forth.

**Order for vacation of building.** The undersigned building official has determined that the building or structure must be vacated as required by Section 108.2 of the International Property Maintenance Code, 2015 edition. Therefore, it is hereby ordered

**EXHIBIT D**

that the building or structure shall be vacated immediately on this day 14<sup>th</sup> day of June, 2018.

**Order to secure building.** The undersigned building official has determined that the building must be secured immediately. Therefore, it is hereby ordered that all means of entering the building be secured to prevent unauthorized entrance. An inspector will verify compliance on Monday, June 18, 2018. Failure to secure the building will result in the City of Fargo hiring an independent contractor to secure the building. All expenses for securing the building will be assessed against the property.

**Order for repair.** The undersigned building official has determined that the building must be repaired. Therefore, it is hereby ordered that all required permits be secured for the appropriate repair of the building or structure. A new permit must be obtained within 30 days of this letter.

**NOTICE OF RIGHT TO APPEAL**

**PLEASE BE ADVISED** that any person having any record, title, or legal interest in the building, described above, may appeal from this Notice and Order or any action of the undersigned building official to the Housing Advisory and Appeals Board, provided the appeal is made in writing as provided in the International Property Maintenance Code 2015 edition, and filed with the undersigned building official within 30 days from the date of service of this Notice and Order. Please be further advised that failure to appeal this Notice and Order will constitute a waiver of all right to an administrative hearing and determination of the matter.

The foregoing constitutes the order of the undersigned building official under the authority set forth by the provisions of the Fargo Municipal Code and the International Property Maintenance Code 2015 edition, and the required notice of right to appeal.

Dated this 14<sup>th</sup> day of June, 2018.



---

**Bruce Taralson**  
**Inspections Administrator**  
**200 3<sup>rd</sup> Street N., Fargo, ND 58102**  
**701-241-151**

Conditions Found Statement

On June 12, 2018, inspector, Joseph Girdner, was present at the 427 15 AVENUE S., FARGO, ND 58103 for a consultation. The following violations were found:

- Building is structurally unsound.
- Many and various code violations.
- Multiple permits filed as incomplete.
- Work completed without necessary permits.
- Substandard workmanship.

**Please note: current permit, BL20180708, is hereby voided.**

The following actions must be taken:

- Provide engineering on structure, mechanical, plumbing and electrical.
- Provide structural plans.
- Provide list of licensed trades with plans.
- Obtain new permit and follow through with all necessary inspections.



**Joseph Girdner  
Building Inspector  
City of Fargo, ND**



INSPECTIONS DIVISION  
City of Fargo  
200 3rd Street North  
Fargo, North Dakota 58102

Return Service Requested

**CERTIFIED MAIL**



7017 1450 0001 2557 3974

64

6/19/18

James Peter Sabo  
1221 9 Ave N  
Fargo N

NIXIE

581 DE 1

RETURN TO SENDER  
UNCLAIMED  
UNABLE TO FORWARD

UNC  
5810235573974

BC: 58102480900



UNITED STATES POSTAGE  
THIRTY BOWS  
\$06.67  
02 1R  
0002004795  
JUN 14 2018  
MAILED FROM ZIP CODE 58102

0007705718

**U.S. Postal Service™**  
**CERTIFIED MAIL® RECEIPT**  
Domestic Mail Only

For delivery information, visit our website at [www.usps.com](http://www.usps.com)®.

**OFFICIAL USE**

Certified Mail Fee

6-14-18

- Extra Services & Fees (check box, add fee as appropriate)
- Return Receipt (hardcopy) \$
- Return Receipt (electronic) \$
- Certified Mail Restricted Delivery \$
- Adult Signature Required \$
- Adult Signature Restricted Delivery \$
- Postage \$
- Total Postage and Fees \$

Postmark  
Here

Sent To  
James P Sabo  
Street and Apt. No. or PO Box No.  
1221 9 Ave N  
City, State, ZIP+4®  
FARGO, ND 58102

PS Form 3800, April 2015 PSN 7530-02-000-9047 See Reverse for Instructions

7017 1450 0001 2557 3974



# Fargo Inspections

City of Fargo  
200 Third Street North  
701-241-1561  
701-476-6779 fax



## NOTICE OF DANGEROUS BUILDING

TO: JAMES PETER SABO

YOU ARE HEREBY Given Notice of the following:

1. That this Notice is being given to you pursuant to Fargo Municipal Code, Article 21-04 concerning Dangerous Buildings. This Notice of Dangerous Building takes precedence over the Notice of Substandard Building Order dated June 14, 2018.
2. That the building with which this Notice is concerned is commonly known as 427 15 Avenue South, Fargo, North Dakota, and is located on that tract of land in the city of Fargo, more particularly described as follows:  
  
Lot 113, ADDN# 0120, (Belmont Park)  
  
(hereinafter referred to as "the building")
3. That an inspection was made of the building on June 12, 2018 by Joseph Girdner, Building Inspector, and on June 22, 2018 by Robert Harshberger, Deputy Assessor, of the City of Fargo.
4. That the building inspector for the City of Fargo has found the building, consisting of a multistory, wood-framed structure to be a Dangerous Building within the standards set forth in the Fargo Municipal Code, Article 21-04, Dangerous Buildings and IPMC Code 108.1.5 concerning Dangerous Structures.
5. That the owner of the building must demolish the building within 30 (thirty) days from the date of this notice or obtain a permit to repair. To obtain a permit, see 'Conditions Found Statement' below.
6. That the building is unsafe and is a dangerous building in the following respects: See 'Conditions Found Statement' below.
  - A. Robert Harschberger, Deputy Assessor, of the City of Fargo has deemed that the building has been damaged or deteriorated to the extent of more than fifty (50) percent of its original value prior to the damage or deterioration.

Source: Fargo Municipal Code, Article 21-0402 concerning Dangerous Buildings.

# EXHIBIT E

7. The building is unsafe and constitutes a public nuisance pursuant to Fargo Municipal Code, Article 21-04 concerning Dangerous Buildings and Section 116 of the International Building Code as adopted by Article 21-0101 of the Fargo Municipal Code.

8. You are further given Notice that unless the building is demolished within the time period set forth herein, the City of Fargo will take such steps as are necessary to cause said building to be demolished pursuant to Fargo Municipal Code, Article 21-04 concerning Dangerous Buildings and the International Building Code and the owner will be assessed such costs as are provided for therein.

9. Order for vacation of building. The undersigned building official has determined that the building or structure must be vacated as required by Section 108.2 of the International Property Maintenance Code, 2015 edition. Therefore, it is hereby ordered that the building or structure shall be vacated immediately, and remain vacated, on this 25<sup>th</sup> day of June, 2018.

10. Order to secure building. The undersigned building official has determined that the building must remain secured. Therefore, it is hereby ordered that all means of entering the building remain secured to prevent unauthorized entrance. **An inspector will continue to verify compliance.** Failure to keep the building secured will result in the City of Fargo hiring an independent contractor to secure the building. All expenses for securing the building will be assessed against the property.

Dated this 25<sup>th</sup> day of June, 2018.



---

Bruce Taralson  
Inspections Administrator

Conditions Found Statement

This statement has been updated on this 25<sup>th</sup> day of June, 2018 to reflect new information obtained after June 12, 2018 for the Notice of Dangerous Building. Added information has been underlined.

On June 12, 2018, inspector, Joseph Girdner, was present at the 427 15 Avenue S., Fargo, ND 58103 for a consultation. The following violations were found:

- Building is structurally unsound.
- Many and various code violations.
- Multiple permits filed as incomplete.
- Work completed without necessary permits.
- Substandard workmanship.

Added June 25, 2018:

- All existing conditions of building need to be exposed in order to be inspected to determine if the building is allowed to remain. This may include removing all existing interior finishes.

Permits BL20180708 and BL20180955 (added June 25, 2018), are hereby voided.

The following actions must be taken:

- Provide engineering on structure, mechanical, plumbing and electrical.
- Provide structural plans, floor plans and truss drawings (added June 25, 2018).
- Provide list of licensed trades with plans.
- Obtain a new permit and follow through will all necessary inspections.



Joseph Girdner  
Building Inspector  
City of Fargo, ND

6/25/18  
Date Signed

DATE: June 22, 2018  
TO: Joseph Girdner, Residential Building Inspector  
FROM: Robert E Harshberger, Deputy Assessor  
SUBJECT: 01-0120-01070-000 / 427 15 Ave S / Sabo, James Peter (Owner)

On June 22, 2018, I inspected the exterior of the subject residential building and reviewed numerous interior photographs of the subject residential building provided by the inspections department to determine if the deterioration of the above referenced structure would qualify it as a dangerous building as defined in city ordinance. One requirement of that classification is that the cost to repair would exceed fifty percent (50%) of the building value as established by the Fargo Assessment Department.

Based on observed component conditions and the interior photographs, I have estimated a cost to repair that exceeds the minimum fifty- percent.

**EXHIBIT F**



701-729-6231  
 PETE  
**SANDMAN**  
 Structural Engineers

7/17/18 PV

July 5, 2018

Pete Sabo  
 1221 9<sup>th</sup> Ave N  
 Fargo, ND 58102

RE: 427 15<sup>th</sup> Ave S, Fargo ND

Sandman Structural Engineers (SSE) was retained to review the property at 427 15<sup>th</sup> Avenue South, Fargo, ND. The purpose of the visit was to review the residence which is currently being remodeled and provide opinion as to what areas need attention. A site visit was made on 7/2/18 to review the current progress and condition of the property. The list below identifies the items discussed during the site visit as deficient that require remediation.

Observations:

**1. Main Floor Openings/Headers**

a. Current Condition:

- i. The original construction did not utilize headers above the main floor window or door openings.

b. Recommendation:

- i. Due to the additional level, new (2)-2x8 headers must be added to the openings on the main floor to support the loads from above. The opening framing also needs to have one additional king stud added to each supporting end of the opening.

**2. Interior Beam**

a. Current Condition:

- i. There is lack of interior bearing support for the second-floor joists.

b. Recommendation:

- i. A new W12x26 steel beam must be added to support the second-floor joists. This steel beam shall have a 2x6 wood plate bolted to the top flange and the second-floor joists shall have full bearing on the beam. The south end of the steel beam shall be supported by an HSS 3x3x 3/16 steel column down to the basement slab level and rest on a new 30" square footing. The north end of the beam will have a W12x26 transfer beam to allow for the stair opening below. Each end of the transfer is to be supported by an HSS 3x3x 3/16 steel column down to the basement slab level and rest on a new 24" square footing. The steel fabricator to provide shop drawings for review.

**3. Second Floor Joists**

a. Current Condition:

- i. The second-floor joists are inconsistent and have discontinuous members and members with notches and holes in them. Several plies have been added in attempt to make a continuous floor joist. There are also existing floor penetrations that were part of the framing that were infilled.

b. Recommendation:

- i. The existing laminated floor joists must be abandoned, and a new continuous un-notched joist be added in each location that there is not a true continuous un-notched member. The new joists must bear on the exterior wall a minimum of 3" and have full bearing on the new steel beam line supporting the interior bearing location. The existing floor penetrations must be removed to allow for continuous joists to span from the exterior wall to the interior beam.

**4. Existing Second Floor Piping**

a. Current Condition:

- i. There is second level bathroom piping that has been run through second floor joists.

b. Recommendation:

- i. This piping must be removed and placed in a chase or below the framing, so joists will not be cut, or holes bored in them.

**5. Upper Stair Bearing Wall**

a. Current Condition:

- i. There is new bearing wall installed to support shortened second-floor joists at the stair location. This wall bears on the first-floor joists.

b. Recommendation:

- i. If this wall is to remain, a bearing wall must be placed below the first-floor joists directly under this wall supported by the basement slab as the first-floor joists cannot support a bearing wall.

**6. Foundation Walls**

a. Current Condition:

- i. There are wide horizontal cracks in the foundation wall as a result of inward movement due to the active soil pressure.

b. Recommendation:

- i. New W4x13 vertical steel braces should be placed on either side of basement window locations and otherwise spaced at 6'-0" on center all around the basement foundation. These braces shall be grouted in at the base and properly blocked in to the floor framing at the first floor with bolted blocking. The braces shall be in contact with the wall and the gap shall be grouted solid with non-shrink grout.

**7. Second Floor Sub-Floor**

a. Current Condition:

- i. There are areas of non-uniform sub-flooring on the second level.

b. Recommendation:

- i. Continuous 3/4" tongue and groove sub-flooring shall be nailed and glued to the second-floor joists. Filler plywood may be used below the 3/4" sub-floor if it is competent non-degraded plywood to make up any elevation differential.

SSE appreciates the opportunity to provide this evaluation and recommendations. If you have any questions, please feel free to call at any time.

Thank you,



Kurt Sandman, PE  
Owner/Principal

Wolf Steel Construction Inc.

1408 2nd Ave North  
Fargo, ND 58102

# Invoice

Date	Invoice #
7/26/2018	9294

**Bill To**  
Pete Sabo

**PAID**  
7/26/2018

**Ship To**

P.O. Number	Terms	Rep	Ship	Via	F.O.B.	Project
	Due on receipt		7/26/2018			

Quantity	Item Code	Description	Price Each	Amount
1	Fabrication	Materials Only- 2 beams , 3 columns primed. 1 field measure trip Jopbsite delv. Sales Tax	2,769.00	2,769.00T
			7.50%	207.68

**EXHIBIT H**

Bless Our Friends "Indeed"

**Phone #**  
7012396968

**E-mail**  
DONNA@WOLFSTEEL.COM

**Total**  
Web Site \$2,976.68

[www.wolfsteel.com](http://www.wolfsteel.com)





1408 2nd Avenue North • Fargo, North Dakota 58102

Office: 701-239-6968 • Fax: 701-232-1099 • E-mail: [Curtis@wolfsteel.com](mailto:Curtis@wolfsteel.com) • [www.wolfsteel.com](http://www.wolfsteel.com)

July 2, 2018

To: Pete Sabo

Regards to: House Beam  
Fargo, ND

Based on the drawings dated 5/24/18, I have determined that we will supply the materials for the items listed below. **Base off from Sandman Structural drawings only.**

**Base Bid:**

**Materials only**

- 1. 05 1200 Structural Steel
  - 2 – Beams
    - i. Primed
  - 3 – Columns
    - i. Primed
    - ii. Base and Top Plates
  - 1 – Field Measurement Trip
  - Job Site Delivery (Fargo, ND)

**Total: \$2,769.00 Plus tax**

**Exclusions:**

- (1) Taxes
- (2) Unloading, Installation, & Erection (Erection will bid separate)
- (3) Touchup paint, galvanizing repair, and field painting
- (4) Shoring of any kind
- (5) Grout and grouting
- (6) Engineering or design work of any kind
- (7) Expansion joint covers and column wraps covers
- (8) Access doors or panels
- (9) Deck supports at small openings and/or around columns (unless specifically included above)

- (10) Plate 1/8" (10 Ga.) or lighter unless specifically included, & Pre-engineered metal framing
- (11) Field planning, field measuring, field surveys, or as-built surveys
- (12) Finish paint systems
- (13) AISC certified shop
- (14) All Aluminum and Stainless Steel
- (15) Bolts and supports for other trades, wood to Steel Fasteners
- (16) All steel shown on Electrical, Mechanical, and Plumbing Drawings
- (17) Items not sized or specified on drawings
- (18) All special inspection costs, or per-diems from an outside inspector or agency
- (19) Rebar, rebar couplers, and welding of the same to structural steel
- (20) Supply and install of DBA's
- (21) Unistrut materials of any kind

**Qualifications:**

- 1. Price is F.O.B Jobsite
- 2. All schedules must be mutually agreed upon by the customer and Wolf Steel Construction – Delivery schedule to be determined
- 3. No back charges will be accepted without Wolf Steel Construction's written acceptance of the back charge prior to commencement of the work
- 4. All work to be performed in a standard 40-hour work week
- 5. Price based on no retainage, penalties, or liquidated damages
- 6. Stairs to be supplied broken down – not in assemblies
- 7. The drawings are owned by Wolf Steel Construction and is not to be shared with others for manufacturing purposes.
- 8. Wolf Steel Construction reserves the right to review material pricing and adjust per market conditions.
- 9. No "pay if paid" or "pay when paid" terms to be accepted
- 10. Cash or net 30 days for customers with Pre-Approved Credit. Interest will be charged on past due accounts
- 11. Payment for fabricated and un-fabricated materials that are suitably stored and assured in our yard is required
- 12. Paint: One coat standard gray shop primer
- 13. Cleaning: Hand Tool/SSPC-SP2

We acknowledge (0) addendums

This bid is good for 15 calendar days.

Terms: This proposal document, as amended by mutual agreement, shall become a part of the subcontract agreement. NET 30, No Retainage allowed, 18% annual rate on unpaid balance, plus collection fees.

Respectfully Yours,

*Curtis L Pederson*

Curtis L Pederson

Estimator

Project Name: House Beam – Pete Sabo

Date: July 2, 2018

NOTE: CONTRACT MUST BE SIGNED BEFORE MATERIAL CAN BE ORDERED. Acceptance of this proposal constitutes acceptance of Wolf Steel Construction's Standard Terms and Conditions.

Accepted:

*Pete Sabo*

\_\_\_\_\_  
Company Name

\_\_\_\_\_  
Signature

\_\_\_\_\_  
Print Name & Title

\_\_\_\_\_  
Date

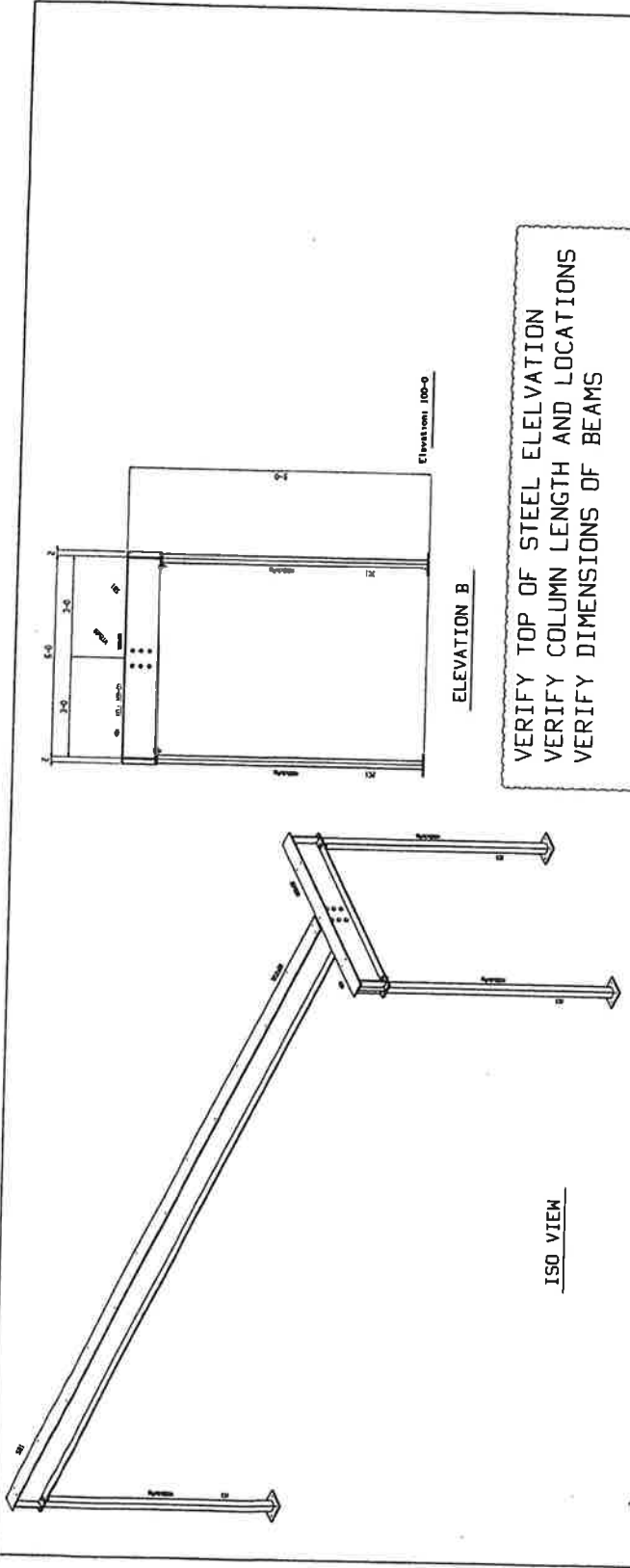

VERIFY TOP OF STEEL ELEVATION  
VERIFY COLUMN LENGTH AND LOCATIONS  
VERIFY DIMENSIONS OF BEAMS

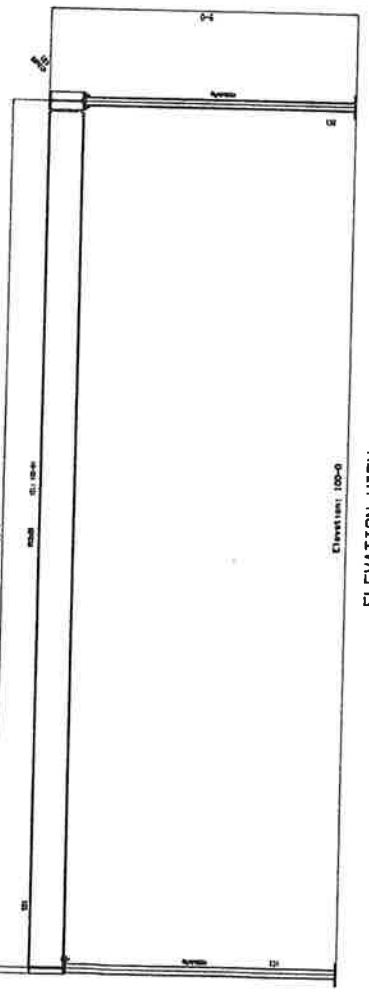

**NOTES:**  
 1. ALL WORK SHALL BE DONE IN ACCORDANCE WITH THE AISC 13TH EDITION SPECIFICATIONS FOR STRUCTURAL STEEL CONSTRUCTION.  
 2. ALL DIMENSIONS SHALL BE SHOWN ON ALL DRAWINGS.  
 3. ALL DIMENSIONS SHALL BE SHOWN TO THE CENTER OF GRAVITY UNLESS OTHERWISE NOTED.  
 4. ALL DIMENSIONS SHALL BE SHOWN TO THE FACE UNLESS OTHERWISE NOTED.  
 5. ALL DIMENSIONS SHALL BE SHOWN TO THE CENTER OF GRAVITY UNLESS OTHERWISE NOTED.  
 6. ALL DIMENSIONS SHALL BE SHOWN TO THE FACE UNLESS OTHERWISE NOTED.  
 7. ALL DIMENSIONS SHALL BE SHOWN TO THE CENTER OF GRAVITY UNLESS OTHERWISE NOTED.  
 8. ALL DIMENSIONS SHALL BE SHOWN TO THE FACE UNLESS OTHERWISE NOTED.  
 9. ALL DIMENSIONS SHALL BE SHOWN TO THE CENTER OF GRAVITY UNLESS OTHERWISE NOTED.  
 10. ALL DIMENSIONS SHALL BE SHOWN TO THE FACE UNLESS OTHERWISE NOTED.

**PROJECT:** 100-0  
**DATE:** 10/10/00  
**DRAWN BY:** [Signature]  
**CHECKED BY:** [Signature]  
**SCALE:** 1/4" = 1'-0"  
**PROJECT:** 100-0  
**DATE:** 10/10/00  
**DRAWN BY:** [Signature]  
**CHECKED BY:** [Signature]  
**SCALE:** 1/4" = 1'-0"

**Half Steel Construction, Inc.**  
 100-0  
 10/10/00  
 1/4" = 1'-0"

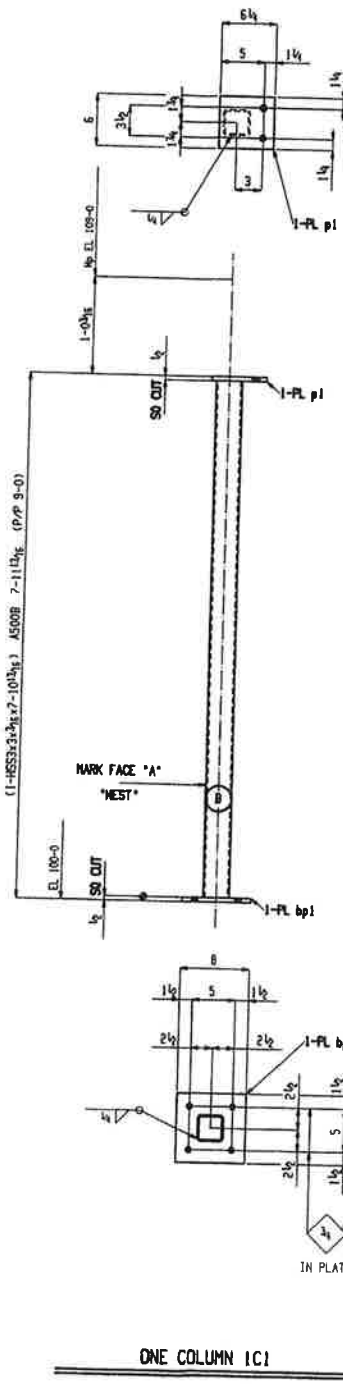

**SPEC NOTES:**

- 1.3 WIDE FLG. MTL. ASY. PER Q1-20 U.N. OTHER MTL. ASY. USE U.N. PIPE MTL. ASTM A53, GRADE B U.L.
- 2.15 MTL. STRENGTH SHALL BE AS SHOWN ON THE DRAWING.
- 3.1 WELD TO BE PER AISC 360. FOR ALL JOINTS, WELDS TO BE A500-B TYPE 1 U.G. W. FOR ALL JOINTS.
- 3.2 WELDS AT CONNECTION SHALL BE 1/4" MIN. THICK. FOR ALL JOINTS, WELDS TO BE A500-B TYPE 1 U.G. W. FOR ALL JOINTS.
- 3.3 WELD BEHIND MOVER OVER ALL JOINTS IN CONNECTION SHALL BE 1/4" MIN. THICK. FOR ALL JOINTS, WELDS TO BE A500-B TYPE 1 U.G. W. FOR ALL JOINTS.
- 4.1 USE 1/2" HIGH STRENGTH WOODER OVER ALL JOINTS IN CONNECTION SHALL BE 1/4" MIN. THICK. FOR ALL JOINTS, WELDS TO BE A500-B TYPE 1 U.G. W. FOR ALL JOINTS.
- 5.1 QUALIFIED WELDER PER 9.100 ELECTRODES / FILLER METAL (SPERM-COM-004 PROCESSES)
- 5.2 WELDS SHALL BE INSPECTED PER 9.100 (BY INDEPENDENT LAB.)

**ALL VERIFICATION REQUESTS ON THIS SET OF DRAWINGS WILL BE ASSIGNED TO THE CORRECT AS SHOWN UNLESS OTHERWISE NOTED. WHERE FABRICATOR HAS REQUESTED INFORMATION TO BE PROVIDED, CONTRACTOR IS RESPONSIBLE TO COORDINATE WITH TRADES, ARCH, AND CONSULTING ENGINEER TO COMPLETE VERIFICATION REQUESTS. ON STEEL DELIVERY MAY BE DELAYED. ANY VERIFICATION COST ARE TO BE COVERED BY CONTRACTOR. VERIFICATION REQUESTS WILL BE COVERED BY CONTRACTOR...**

**NO BACK CHANGES ACCEPTED WITHOUT WRITTEN APPROVAL FROM WOLFSTEEL CONSTRUCTION INC. DOCUMENTATION MUST INCLUDE PER WOLFSTEEL CONSTRUCTION INC. APPROVAL AND COST OF RERWORK REPRODUCTION OF FABRICATOR FROM THIS DRAWING IS NOT PERMITTED WITHOUT WRITTEN PERMISSION FROM WOLFSTEEL CONSTRUCTION INC.**

**PROJECT: PETE SARDI HOUSE**  
**LOCATION: FAYO, MO**  
**CONTRACTOR: WOLFSTEEL CONSTRUCTION INC**  
**FILE INFO: FILE INFO**

**PREP: DEJ**  
**DATE: 8/18/2016**

**CHK: PS**  
**DATE: 8/18/2016**

**FINISH NOTE: ONE COAT OXIDE PRIMER**

NO.	QTY	UNIT	DESCRIPTION	LENGTH	WEIGHT	REMARKS	TOTAL	UNIT
1								

total weight : 89

**WOLF STEEL CONSTRUCTION INC**  
 WOLFSTEEL CONSTRUCTION INC  
 1400 Paul Ave. II  
 Perry, MO 64777  
 Phone: 781.226.2288

**Half Steel Constructio Inc**

REV 1 DATE DESCRIPTION

1 2/12/2016 (Per Approval) DESCRIPTION

(1-HSS3.3x1x2-10<sup>3</sup>kg) AS608 7-11<sup>3</sup>/<sub>16</sub> (P.P. 9-0)

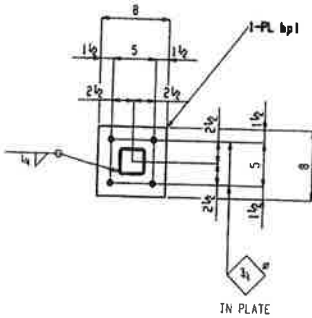
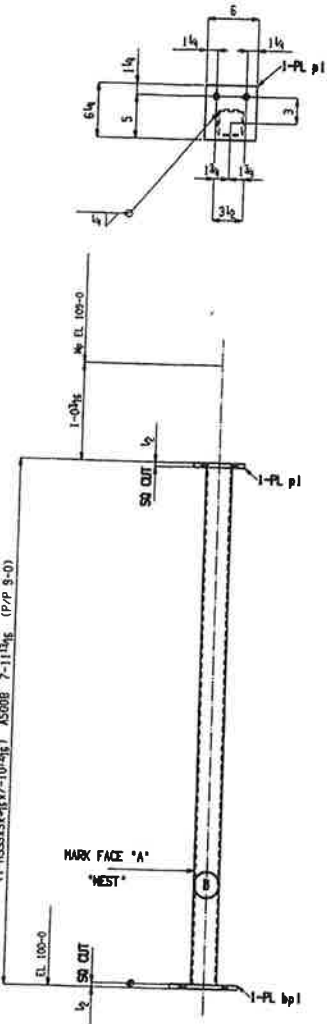

ONE COLUMN 2C1

SHOP NOTES:  
 1. ALL STEEL SHALL BE A36 OR 50 U.S. OTHER INT'L. ASTM OR U.S. PIPE INT'L. ASTM A53, GRADE B U.S.  
 2. ALL WELDS SHALL BE PER AISC 3.08.  
 3. ALL SHEET PILING SHALL BE PER AISC 3.08.  
 4. ALL CONNECTIONS SHALL BE PER AISC 3.08.  
 5. ALL CONNECTIONS SHALL BE PER AISC 3.08.  
 6. ALL CONNECTIONS SHALL BE PER AISC 3.08.  
 7. ALL CONNECTIONS SHALL BE PER AISC 3.08.  
 8. ALL CONNECTIONS SHALL BE PER AISC 3.08.  
 9. ALL CONNECTIONS SHALL BE PER AISC 3.08.  
 10. ALL CONNECTIONS SHALL BE PER AISC 3.08.

ALL VARIATIONS REQUESTED ON THIS SET OF DRAWINGS WILL BE APPROVED AS SHOWN UNLESS OTHERWISE NOTED. THESE FABRICATOR HAS REQUESTED DETERMINATION TO BE PROVIDED, CONTRACTOR IS RESPONSIBLE TO CONDUCE WITH TOLERANCE, AND, AND EXCEEDED AS NOTED, TO COMPLETE VARIATION REQUESTS, OR FIELD DELIVERY MAY BE DELAYED. ANY REVISIONS MUST BE TO COMPLETE OR IMMEDIATE VARIATION REQUESTS WILL BE HELD AS EXTRA TO THE CONTRACT... NO BACK CHANGES ACCEPTED WITHOUT WRITTEN APPROVAL FROM WOLF STEEL CONSTRUCTION INC. DOCUMENTATION MUST INCLUDE PERMITS, INVOICES REQUIRED AND COST OF NETWORK REPLICATION OR FABRICATION FROM THIS DRAWING IS NOT PERMITTED NETWORK REPLICATION PERMISSION FROM WOLF STEEL CONSTRUCTION INC.

FINISH NOTE: ONE COAT OXIDE PRIMER

NO.	PK	ORDER	QTY	TOTAL	DESCRIPTION	REMARKS	REMARKS
1	2C1	1	1	1	1-HSS3.3x1x2-10 <sup>3</sup> kg	2-100% ZNC OXIDE	54
2		1	1	1	1-PL bp1	2-100% ZNC OXIDE	54
3		1	1	1	1-PL bp1	2-100% ZNC OXIDE	54
4		1	1	1	1-PL bp1	2-100% ZNC OXIDE	54
5		1	1	1	1-PL bp1	2-100% ZNC OXIDE	54

Total weight: 83

PROJECT: PETE SAUND HOUSE  
 LOCATION: FARM, MO  
 DRAWN BY: [Name]  
 CHECKED BY: [Name]  
 DATE: [Date]

**Wolf Steel Construction Inc**  
 1400 2nd Ave. S  
 Fargo, ND 58102  
 Phone: 701.228.0888

2C1

(1-HSS3x3x3/16x7-10 1/4) A500B 7-11 3/4 (PP 9-0)

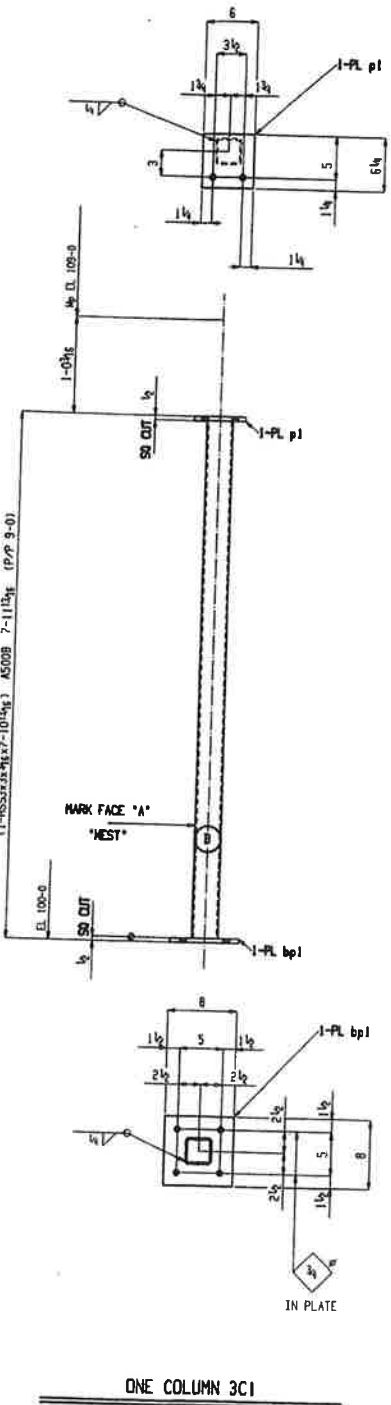

ONE COLUMN 3C1

- SHOP NOTES:**
- 1.) WIDE FLG. INLT. ASTM A588 GR.50 U.S. OTHER WTL. ASTM A36 U.S. PIPE INLT. GRN. STD. GRADE 8 U.S.
  - 2.) HSS. ONLY. NO. 3 U.S.
  - 3.) HSS. ONLY. NO. 3 U.S.
  - 4.) USE 1/8" HIGH STRENGTH WASER OVER ALL JOINTS IN CONNECTION WELDS. WELDS MUST BE THROU CONTROL. TYPE 1.
  - 5.) ALL WELDED CONNECTIONS MUST BE MADE BY THE CONTRACTOR AND SHALL BE MADE BY THE CONTRACTOR.
  - 6.) ALL WELDED CONNECTIONS MUST BE MADE BY THE CONTRACTOR AND SHALL BE MADE BY THE CONTRACTOR.
- FINISH NOTE: ONE COAT OXIDE PRIMER**

NO BACK CHARGES ACCEPTED WITHOUT WRITTEN APPROVAL FROM WOLF STEEL CONSTRUCTION INC.  
 DOCUMENTATION MUST INCLUDE PC MARK, REWORK REQUIRED AND COST OF REWORK.  
 REWORK AND FABRICATION FROM YOUR MANAGER IS NOT ACCEPTED WITHOUT WRITTEN PERMISSION FROM WOLF STEEL CONSTRUCTION INC.

SQ. NO.	PK. NAME	QTY.	UNIT	DESCRIPTION	WEIGHT	MARKS	
						NET WT.	TOTAL WT.
3C1	ONE COLUMN	1	0.000	ONE COLUMN	34		

Total weight: 63

**WOLF STEEL CONSTRUCTION, INC.**  
 PROJECT: PETE SAND HOUSE  
 LOCATION: FAHO, MO  
 DRAWING: N18-PS  
 FILE NUMBER: 1104135689  
 SHEET: 3C1

REV. DATE: 01/25/2018  
 BY: [Signature]  
 FOR APPROVAL: [Signature]  
 DESCRIPTION: [Signature]

**Wolf Steel Construction, Inc.**  
 1830 Paul Jones Dr.  
 Fayette, MO 65240  
 Phone: 781-295-8888

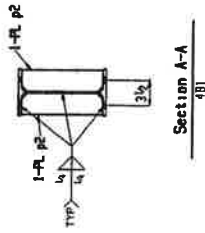
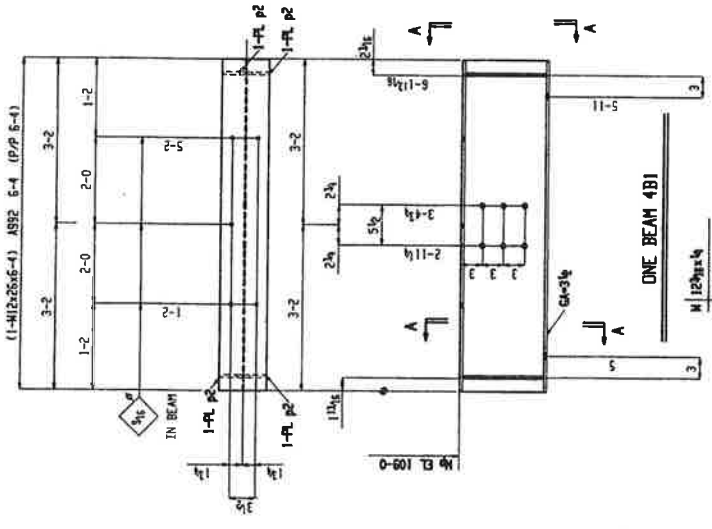

**BILL OF MATERIAL**

SEQ	PC	QTY	DESCRIPTION	LENGTH	WEIGHT	TOTAL
1	4BI	1	ONE BEAM	24	179	
2	PL	4	1/4 PL	0 11/4	185	
3	PL	4	1/4 PL	0 2 1/4	18	

NOTES:

1. ALL WELDS SHALL BE WELDED TO U.S. STEEL CODES. OTHER WELDS SHALL BE WELDED TO U.S. STEEL CODES. OTHER WELDS SHALL BE WELDED TO U.S. STEEL CODES.
2. ALL WELDS SHALL BE WELDED TO U.S. STEEL CODES. OTHER WELDS SHALL BE WELDED TO U.S. STEEL CODES.
3. ALL WELDS SHALL BE WELDED TO U.S. STEEL CODES. OTHER WELDS SHALL BE WELDED TO U.S. STEEL CODES.
4. ALL WELDS SHALL BE WELDED TO U.S. STEEL CODES. OTHER WELDS SHALL BE WELDED TO U.S. STEEL CODES.
5. ALL WELDS SHALL BE WELDED TO U.S. STEEL CODES. OTHER WELDS SHALL BE WELDED TO U.S. STEEL CODES.
6. ALL WELDS SHALL BE WELDED TO U.S. STEEL CODES. OTHER WELDS SHALL BE WELDED TO U.S. STEEL CODES.

ALL INFORMATION CONTAINED ON THIS SET OF DRAWINGS WILL BE ASSUMED CORRECT AS SHOWN UNLESS OTHERWISE NOTED. THE CONTRACTOR SHALL BE RESPONSIBLE FOR OBTAINING ALL NECESSARY PERMITS AND APPROVALS FROM THE LOCAL, STATE AND FEDERAL AUTHORITIES. THE CONTRACTOR SHALL BE RESPONSIBLE FOR OBTAINING ALL NECESSARY PERMITS AND APPROVALS FROM THE LOCAL, STATE AND FEDERAL AUTHORITIES. THE CONTRACTOR SHALL BE RESPONSIBLE FOR OBTAINING ALL NECESSARY PERMITS AND APPROVALS FROM THE LOCAL, STATE AND FEDERAL AUTHORITIES.

FINISH NOTE: ONE COAT OXIDE PRIMER

**WOLF STEEL**  
CONSTRUCTION, INC.  
1500 1st Ave. S.  
Ft. Worth, TX 76102  
Phone: 702.228.8888

**Wolf Steel Construction, Inc**

PROJECT: PETE SAND NOISE  
LOCATION: FARM #8  
CONTRACT: 4BI  
FILE NUMBER: 4BI

Total weight: 179



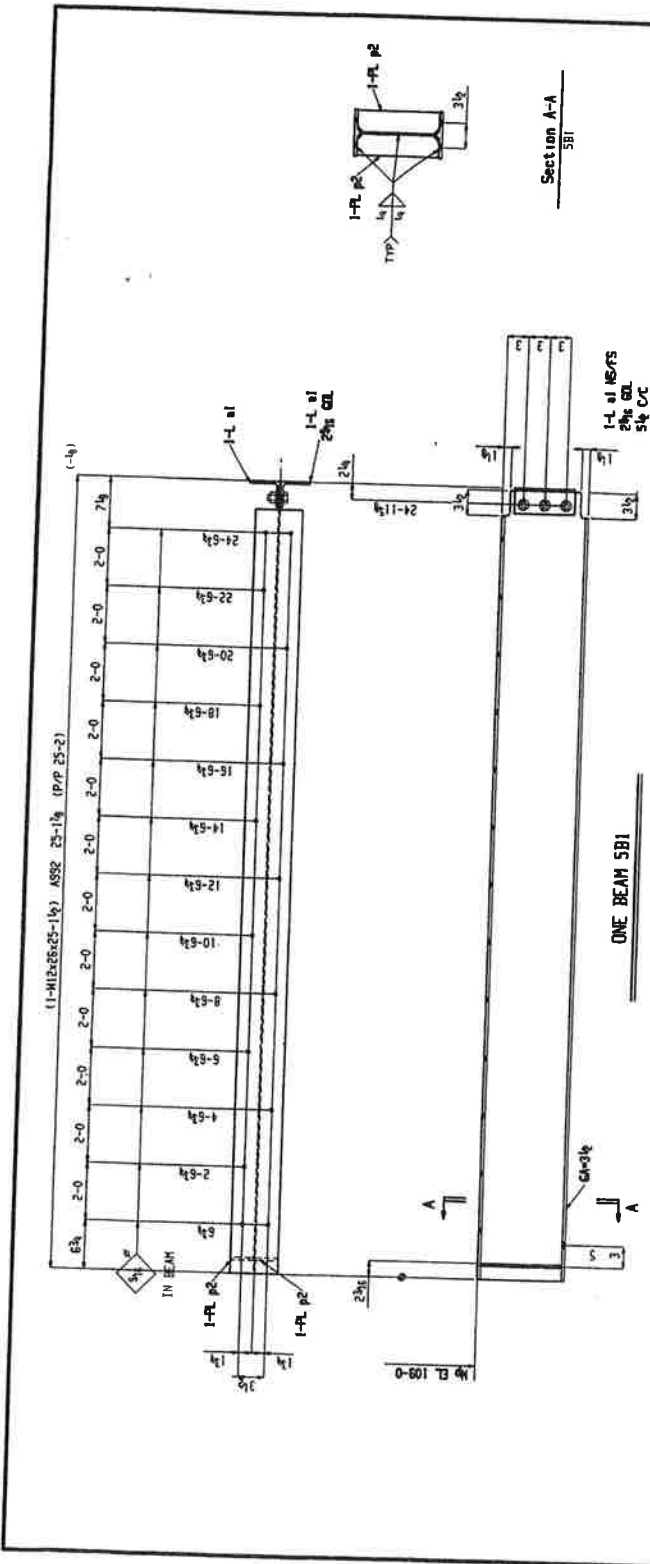

ONE BEAM 5B1

1-L 2x12  
F 1/4x4  
K 1/4x4

SHOP BOLTS:  
3-1/2x2 1/2 A325

Section A-A  
5B1

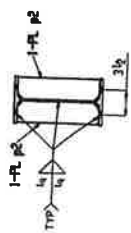

BILL OF MATERIAL

NO	PC	QUANTITY	DESCRIPTION	LENGTH	WEIGHT	TOTAL	REMARKS
1	5B1	1	1x12	25.14	492	492	
2	5B1	2	1x10	27.04	405	810	
3	5B1	2	1x8	27.04	324	648	
4	5B1	2	1x6	27.04	216	432	
5	5B1	2	1x4	27.04	108	216	
6	5B1	2	1x2	27.04	54	108	
7	5B1	2	1x1	27.04	27	54	
8	5B1	2	1x1/2	27.04	13.5	27	
9	5B1	2	1x1/4	27.04	6.75	13.5	
10	5B1	2	1x1/8	27.04	3.375	6.75	
11	5B1	2	1x1/4	27.04	6.75	13.5	
12	5B1	2	1x1/8	27.04	3.375	6.75	
13	5B1	2	1x1/4	27.04	6.75	13.5	
14	5B1	2	1x1/8	27.04	3.375	6.75	
15	5B1	2	1x1/4	27.04	6.75	13.5	
16	5B1	2	1x1/8	27.04	3.375	6.75	
17	5B1	2	1x1/4	27.04	6.75	13.5	
18	5B1	2	1x1/8	27.04	3.375	6.75	
19	5B1	2	1x1/4	27.04	6.75	13.5	
20	5B1	2	1x1/8	27.04	3.375	6.75	
21	5B1	2	1x1/4	27.04	6.75	13.5	
22	5B1	2	1x1/8	27.04	3.375	6.75	
23	5B1	2	1x1/4	27.04	6.75	13.5	
24	5B1	2	1x1/8	27.04	3.375	6.75	
25	5B1	2	1x1/4	27.04	6.75	13.5	
26	5B1	2	1x1/8	27.04	3.375	6.75	
27	5B1	2	1x1/4	27.04	6.75	13.5	
28	5B1	2	1x1/8	27.04	3.375	6.75	
29	5B1	2	1x1/4	27.04	6.75	13.5	
30	5B1	2	1x1/8	27.04	3.375	6.75	
31	5B1	2	1x1/4	27.04	6.75	13.5	
32	5B1	2	1x1/8	27.04	3.375	6.75	
33	5B1	2	1x1/4	27.04	6.75	13.5	
34	5B1	2	1x1/8	27.04	3.375	6.75	
35	5B1	2	1x1/4	27.04	6.75	13.5	
36	5B1	2	1x1/8	27.04	3.375	6.75	
37	5B1	2	1x1/4	27.04	6.75	13.5	
38	5B1	2	1x1/8	27.04	3.375	6.75	
39	5B1	2	1x1/4	27.04	6.75	13.5	
40	5B1	2	1x1/8	27.04	3.375	6.75	
41	5B1	2	1x1/4	27.04	6.75	13.5	
42	5B1	2	1x1/8	27.04	3.375	6.75	
43	5B1	2	1x1/4	27.04	6.75	13.5	
44	5B1	2	1x1/8	27.04	3.375	6.75	
45	5B1	2	1x1/4	27.04	6.75	13.5	
46	5B1	2	1x1/8	27.04	3.375	6.75	
47	5B1	2	1x1/4	27.04	6.75	13.5	
48	5B1	2	1x1/8	27.04	3.375	6.75	
49	5B1	2	1x1/4	27.04	6.75	13.5	
50	5B1	2	1x1/8	27.04	3.375	6.75	

FINISH NOTE: ONE COAT OXIDE PRIMER

- 1. ALL WELDS TO BE MADE BY WELDER QUALIFIED TO THE STANDARD SPECIFICATIONS FOR WELDED FABRICATIONS.
- 2. ALL WELDS TO BE MADE BY WELDER QUALIFIED TO THE STANDARD SPECIFICATIONS FOR WELDED FABRICATIONS.
- 3. ALL WELDS TO BE MADE BY WELDER QUALIFIED TO THE STANDARD SPECIFICATIONS FOR WELDED FABRICATIONS.
- 4. ALL WELDS TO BE MADE BY WELDER QUALIFIED TO THE STANDARD SPECIFICATIONS FOR WELDED FABRICATIONS.
- 5. ALL WELDS TO BE MADE BY WELDER QUALIFIED TO THE STANDARD SPECIFICATIONS FOR WELDED FABRICATIONS.
- 6. ALL WELDS TO BE MADE BY WELDER QUALIFIED TO THE STANDARD SPECIFICATIONS FOR WELDED FABRICATIONS.
- 7. ALL WELDS TO BE MADE BY WELDER QUALIFIED TO THE STANDARD SPECIFICATIONS FOR WELDED FABRICATIONS.
- 8. ALL WELDS TO BE MADE BY WELDER QUALIFIED TO THE STANDARD SPECIFICATIONS FOR WELDED FABRICATIONS.
- 9. ALL WELDS TO BE MADE BY WELDER QUALIFIED TO THE STANDARD SPECIFICATIONS FOR WELDED FABRICATIONS.
- 10. ALL WELDS TO BE MADE BY WELDER QUALIFIED TO THE STANDARD SPECIFICATIONS FOR WELDED FABRICATIONS.
- 11. ALL WELDS TO BE MADE BY WELDER QUALIFIED TO THE STANDARD SPECIFICATIONS FOR WELDED FABRICATIONS.
- 12. ALL WELDS TO BE MADE BY WELDER QUALIFIED TO THE STANDARD SPECIFICATIONS FOR WELDED FABRICATIONS.
- 13. ALL WELDS TO BE MADE BY WELDER QUALIFIED TO THE STANDARD SPECIFICATIONS FOR WELDED FABRICATIONS.
- 14. ALL WELDS TO BE MADE BY WELDER QUALIFIED TO THE STANDARD SPECIFICATIONS FOR WELDED FABRICATIONS.
- 15. ALL WELDS TO BE MADE BY WELDER QUALIFIED TO THE STANDARD SPECIFICATIONS FOR WELDED FABRICATIONS.
- 16. ALL WELDS TO BE MADE BY WELDER QUALIFIED TO THE STANDARD SPECIFICATIONS FOR WELDED FABRICATIONS.
- 17. ALL WELDS TO BE MADE BY WELDER QUALIFIED TO THE STANDARD SPECIFICATIONS FOR WELDED FABRICATIONS.
- 18. ALL WELDS TO BE MADE BY WELDER QUALIFIED TO THE STANDARD SPECIFICATIONS FOR WELDED FABRICATIONS.
- 19. ALL WELDS TO BE MADE BY WELDER QUALIFIED TO THE STANDARD SPECIFICATIONS FOR WELDED FABRICATIONS.
- 20. ALL WELDS TO BE MADE BY WELDER QUALIFIED TO THE STANDARD SPECIFICATIONS FOR WELDED FABRICATIONS.
- 21. ALL WELDS TO BE MADE BY WELDER QUALIFIED TO THE STANDARD SPECIFICATIONS FOR WELDED FABRICATIONS.
- 22. ALL WELDS TO BE MADE BY WELDER QUALIFIED TO THE STANDARD SPECIFICATIONS FOR WELDED FABRICATIONS.
- 23. ALL WELDS TO BE MADE BY WELDER QUALIFIED TO THE STANDARD SPECIFICATIONS FOR WELDED FABRICATIONS.
- 24. ALL WELDS TO BE MADE BY WELDER QUALIFIED TO THE STANDARD SPECIFICATIONS FOR WELDED FABRICATIONS.
- 25. ALL WELDS TO BE MADE BY WELDER QUALIFIED TO THE STANDARD SPECIFICATIONS FOR WELDED FABRICATIONS.
- 26. ALL WELDS TO BE MADE BY WELDER QUALIFIED TO THE STANDARD SPECIFICATIONS FOR WELDED FABRICATIONS.
- 27. ALL WELDS TO BE MADE BY WELDER QUALIFIED TO THE STANDARD SPECIFICATIONS FOR WELDED FABRICATIONS.
- 28. ALL WELDS TO BE MADE BY WELDER QUALIFIED TO THE STANDARD SPECIFICATIONS FOR WELDED FABRICATIONS.
- 29. ALL WELDS TO BE MADE BY WELDER QUALIFIED TO THE STANDARD SPECIFICATIONS FOR WELDED FABRICATIONS.
- 30. ALL WELDS TO BE MADE BY WELDER QUALIFIED TO THE STANDARD SPECIFICATIONS FOR WELDED FABRICATIONS.
- 31. ALL WELDS TO BE MADE BY WELDER QUALIFIED TO THE STANDARD SPECIFICATIONS FOR WELDED FABRICATIONS.
- 32. ALL WELDS TO BE MADE BY WELDER QUALIFIED TO THE STANDARD SPECIFICATIONS FOR WELDED FABRICATIONS.
- 33. ALL WELDS TO BE MADE BY WELDER QUALIFIED TO THE STANDARD SPECIFICATIONS FOR WELDED FABRICATIONS.
- 34. ALL WELDS TO BE MADE BY WELDER QUALIFIED TO THE STANDARD SPECIFICATIONS FOR WELDED FABRICATIONS.
- 35. ALL WELDS TO BE MADE BY WELDER QUALIFIED TO THE STANDARD SPECIFICATIONS FOR WELDED FABRICATIONS.
- 36. ALL WELDS TO BE MADE BY WELDER QUALIFIED TO THE STANDARD SPECIFICATIONS FOR WELDED FABRICATIONS.
- 37. ALL WELDS TO BE MADE BY WELDER QUALIFIED TO THE STANDARD SPECIFICATIONS FOR WELDED FABRICATIONS.
- 38. ALL WELDS TO BE MADE BY WELDER QUALIFIED TO THE STANDARD SPECIFICATIONS FOR WELDED FABRICATIONS.
- 39. ALL WELDS TO BE MADE BY WELDER QUALIFIED TO THE STANDARD SPECIFICATIONS FOR WELDED FABRICATIONS.
- 40. ALL WELDS TO BE MADE BY WELDER QUALIFIED TO THE STANDARD SPECIFICATIONS FOR WELDED FABRICATIONS.
- 41. ALL WELDS TO BE MADE BY WELDER QUALIFIED TO THE STANDARD SPECIFICATIONS FOR WELDED FABRICATIONS.
- 42. ALL WELDS TO BE MADE BY WELDER QUALIFIED TO THE STANDARD SPECIFICATIONS FOR WELDED FABRICATIONS.
- 43. ALL WELDS TO BE MADE BY WELDER QUALIFIED TO THE STANDARD SPECIFICATIONS FOR WELDED FABRICATIONS.
- 44. ALL WELDS TO BE MADE BY WELDER QUALIFIED TO THE STANDARD SPECIFICATIONS FOR WELDED FABRICATIONS.
- 45. ALL WELDS TO BE MADE BY WELDER QUALIFIED TO THE STANDARD SPECIFICATIONS FOR WELDED FABRICATIONS.
- 46. ALL WELDS TO BE MADE BY WELDER QUALIFIED TO THE STANDARD SPECIFICATIONS FOR WELDED FABRICATIONS.
- 47. ALL WELDS TO BE MADE BY WELDER QUALIFIED TO THE STANDARD SPECIFICATIONS FOR WELDED FABRICATIONS.
- 48. ALL WELDS TO BE MADE BY WELDER QUALIFIED TO THE STANDARD SPECIFICATIONS FOR WELDED FABRICATIONS.
- 49. ALL WELDS TO BE MADE BY WELDER QUALIFIED TO THE STANDARD SPECIFICATIONS FOR WELDED FABRICATIONS.
- 50. ALL WELDS TO BE MADE BY WELDER QUALIFIED TO THE STANDARD SPECIFICATIONS FOR WELDED FABRICATIONS.

WOLF STEEL CONSTRUCTION, INC.  
 PROJECT: PETE SAID HOUSE  
 LOCATION: PAGO, MD  
 ENGINEER:  
 CONTRACTOR:  
 FILE NUMBER: INC

NO.	REV.	DATE	DESCRIPTION

Holf Steel Construct, Inc

1403 2nd Ave. N.  
 P.O. Box 180  
 Phone: 703.275.8000

5B1



## INSPECTIONS

200 3RD STREET NORTH  
FARGO, NORTH DAKOTA 58102  
PHONE: 701-241-1561  
FAX: 701-476-6779

July 18, 2018

James Pete Sabo  
1221 9 Avenue N.  
Fargo, ND 58102

RE: 427 15 Avenue S., Fargo, ND

Dear Mr. Sabo,

In addition to the corrections required by Sandman Engineering's report from 7/2/2018, the following criteria must be met before a permit for 427 15 Avenue S. in Fargo can be issued.

- A complete permit application must be submitted including accurate project valuation.
- The permit application will include a list of licensed subcontractors performing work at 427 15 Avenue S., Fargo
- If you will be the individual obtaining the building permit, written statements from all trades/subcontractors verifying their involvement in the project must be submitted to the Inspections department *prior to the issuance of any permits*. The subcontractors must state their acknowledgement that the entire building will need to come into compliance including all existing, previously installed systems.
- Detailed plans for each floor must be submitted; plans must include locations and measurements of all rooms, bearing walls, stairs, etc.
- If trusses are used, a full set of truss plans are required.
- Provide engineering for steel beam.

Should you have any questions, please feel free to contact me.

Sincerely,

A handwritten signature in cursive script that reads "Joseph Girdner".

Joseph Girdner  
Building Inspector

**EXHIBIT I**

**SENDER: COMPLETE THIS SECTION**

- Complete items 1, 2, and 3.
- Print your name and address on the reverse so that we can return the card to you.
- Attach this card to the back of the mailpiece, or on the front if space permits.

1. Article Addressed to:

James Pete Sabo  
 1221 9 AVE N.  
 Fargo, ND 58102

9590 9402 3427 7275 7145 73



2. Article Number (Transfer from service label)  
 7017 145D 0001 2557 4209  
 PS Form 3811, July 2015 PSN 7550-02-000-9053

**COMPLETE THIS SECTION ON DELIVERY**

A. Signature

*James Sabo*

Agent

B. Received by (Printed Name)

JAMES SABO

C. Date of Delivery

7/12

D. Is delivery address different from item 1?  Yes  No  
If YES, enter delivery address below:

3. Service Type
- Adult Signature
  - Adult Signature Restricted Delivery
  - Certified Mail®
  - Certified Mail Restricted Delivery
  - Certified Mail Restricted Delivery
  - Collect on Delivery
  - Collect on Delivery Restricted Delivery
  - Insured Mail (over \$500)
  - Insured Mail Restricted Delivery
  - Priority Mail Express®
  - Registered Mail™
  - Registered Mail Restricted Delivery
  - Return Receipt for Merchandise
  - Return Receipt for Signature Confirmation™
  - Signature Confirmation™
  - Signature Confirmation Restricted Delivery

Domestic Return Receipt

7017 145D 0001 2557 4209

**U.S. Postal Service™**  
**CERTIFIED MAIL® RECEIPT**  
 Domestic Mail Only

For delivery information, visit our website at [www.usps.com](http://www.usps.com)®

**OFFICIAL USE** 56

71818

- Extra Services & Fees (check box, add fee as appropriate)
- Return Receipt (hardcopy) \$
  - Return Receipt (electronic) \$
  - Certified Mail Restricted Delivery \$
  - Adult Signature Required \$
  - Adult Signature Restricted Delivery \$

Postage \$

Total Postage and Fees \$

Sent To: James Pete Sabo  
 Street and Apt. No., PO Box No., or Care Center No. 1221 9th Ave N  
 City, State, ZIP+4® Fargo, ND 58102  
 PS Form 3811, April 2015 PSN 7550-02-000-9047

See Reverse for Instructions

ARTICLE 21-04 - DANGEROUS BUILDINGS

21-0401. - Definitions.

All buildings or structures which have any or all of the following defects shall be deemed "dangerous buildings":

1. Those whose interior walls or other vertical structural members lean, list, or buckle to such an extent that a plumb line passing through the center of gravity falls outside of the middle third of its base.
2. Those which, exclusive of the foundation, show 33% or more of damage or deterioration of the supporting members or members, or 50% of damage or deterioration of the nonsupporting enclosing or outside walls or covering.
3. Those which have improperly distributed loads upon the floors or roofs or in which the same are overloaded, or which have insufficient strength to be reasonably safe for the purpose used.
4. Those which have been damaged by fire, wind, or other causes so as to have become dangerous to life, safety, morals, or the general health and welfare of the occupants or the people of the city.
5. Those which have become, or are, so dilapidated, decayed, unsafe or unsanitary or which so utterly fail to provide the amenities essential to decent living that they are unfit for human habitation or are likely to cause or aggravate sickness or disease, so as to work injury to the health, morals, safety, or general welfare of those living therein.
6. Those having light, air, and sanitation facilities which are inadequate to protect the health, morals, safety, or general welfare of human beings who live or may live therein.
7. Those having inadequate facilities for egress in case of fire or panic or those having insufficient stairways, elevators, fire escapes, or other means of communication.
8. Those which have parts thereof which are so attached that they may fall and injure members of the public or property.
9. Those which because of their condition are unsafe, unsanitary, or dangerous to the health, morals, safety or general welfare of the people of this city.
10. Those buildings existing in violation of any provision of the Building Code, zoning ordinances, any provision of the Fire Prevention Code or other ordinances of this city.

Source: 1952 Rev. Ord. 21-0401.

21-0402. - Standards for repair, vacation, or demolition.

The following standards shall be followed in substance by the board of city commissioners in ordering repair, vacation, or demolition:

- A. If the "dangerous building" can reasonably be repaired so that it will no longer exist in violation of the terms of this article, it shall be ordered repaired.
- B. If the "dangerous building" is in such condition as to make it dangerous to the health, morals, safety, or general welfare of its occupants, it shall be ordered to be vacated.
- C. In any case where a "dangerous building" is 50% damaged, decayed, or deteriorated from its original value or structure, it shall be demolished, and in all cases where a building cannot be repaired so that it will no longer be in violation of the terms of this article, it shall be demolished. In all cases where a "dangerous building" is a fire hazard existing or erected in violation of the

**EXHIBIT J**

terms of this article or any ordinance of this city or statute of the state of North Dakota, it shall be demolished.

Source: 1952 Rev. Ord. 21-0402.

21-0403. - Dangerous buildings—Nuisances.

All "dangerous buildings" within the terms of § 21-0401 are hereby declared to be public nuisances and shall be repaired, vacated, or demolished as hereinbefore and hereinafter provided.

Source: 1952 Rev. Ord. 21-0403.

21-0404. - Duties of building inspector.

The building inspector shall:

- A. Inspect or cause to be inspected semiannually, all public buildings, schools, halls, churches, theaters, hotels, tenements, commercial, manufacturing, or loft buildings for the purpose of determining whether any conditions exist which render any of such places a "dangerous building" within the terms of § 21-0401 of this article.
- B. Inspect any building, wall, or structure about which complaints are filed by any person to the effect that a building, wall, or structure is or may be existing in violation of this article.
- C. Inspect any building, wall, or structure reported (as hereinafter provided for) by the fire or police departments of this city as probably existing in violation of the terms of this article.
- D. Notify in writing the owner, occupant, lessee, mortgagee, and all other persons having an interest in said building, as shown by the records in the office of the register of deeds of the county of Cass, of any building found by him to be a "dangerous building" within the standards set forth in § 21-0401 of this article, that: (1) the owner must vacate, or repair, or demolish said building in accordance with the terms of the notice and this article; (2) the owner or occupant must vacate said building or may have it repaired in accordance with the notice and remain in possession. Provided, that any person notified under this subsection to repair, vacate, or demolish any building shall be given such reasonable time, not exceeding 30 days, as may be necessary to do, or have done, the work or act required by the notice provided for herein.
- E. Set forth in the notice provided for in subsection (D) hereof a description of the building, or structure deemed unsafe, a statement of the particulars which make the building or structure a "dangerous building" and an order requiring the same to be put in such condition as to comply with the terms of this ordinance within such length of time, not exceeding 30 days, as is reasonable.
- F. Report to the board of city commissioners any noncompliance with the "notice" provided for in subsections (D) and (E) hereof.
- G. Appear at all hearings conducted by the board of city commissioners and testify as to the condition of "dangerous buildings."
- H. Place a notice on all "dangerous buildings" reading as follows: "This building has been found to be a 'dangerous building' by the building inspector. This notice is to remain on this building until it is repaired, vacated, or demolished in accordance with the notice which has been given the owner, occupant, lessee, or mortgagee of this building and all other persons having an interest in said building as shown by the records of the register of deeds of the county of Cass. It is unlawful to remove this notice until such notice is complied with."

Source: 1952 Rev. Ord. 21-0404.

21-0405. - Duties of board of city commissioners.

The board of city commissioners shall:

- A. Upon receipt of a report of the building inspector as provided for in § 21-0404, subsection (F), give written notice to the owner, occupant, mortgagee, lessee and all other persons having an interest in said building as shown by the records of the register of deeds of the county of Cass to appear before it on the date specified in the notice to show cause why the building or structure reported to be a "dangerous building" should not be repaired, vacated, or demolished in accordance with the statement of particulars set forth in the building inspector(s) notice provided for herein in § 21-0404, subsection (E).
- B. Hold a hearing and hear such testimony as the building inspector or the owner, occupant, mortgagee, lessee or any other person having an interest in said building as shown by the records of the register of deeds of the county of Cass shall offer relative to the "dangerous building."
- C. Make written findings of fact from the testimony offered pursuant to subsection (B) as to whether or not the building in question is a "dangerous building" within the terms of § 21-0401.
- D. Issue an order based upon findings of fact made pursuant to subsection (C) hereof commanding the owner, occupant, mortgagee, lessee, and all other persons having an interest in said building as shown by the records of the register of deeds of the county of Cass to repair, vacate, or demolish any building found to be a "dangerous building" within the terms of this article and provided that any person so notified, except the owners, shall have the privilege of either vacating or repairing said "dangerous building."
- E. If the owner, occupant, mortgagee, or lessee fails to comply with the order provided for in subsection (D) hereof, within 10 days, the board of city commissioners shall cause such building or structure to be repaired, vacated, or demolished as the facts may warrant, under the standards hereinbefore provided for in § 21-0402 of this article, and shall, with the assistance of the city attorney, cause the costs thereof to be assessed back against the property in the manner provided by law, or in the alternative, cause the costs of such repair, vacation, or demolition to be recovered in a suit at law against the owner or other proper party.
- F. Report to the city attorney the names of all persons not complying with the order provided for in subsection (D) of this section.

Source: 1952 Rev. Ord. 21-0405.

21-0406. - Violations—Penalty for disregarding notices or orders.

The owner of any "dangerous building" who shall fail to comply with any notice or order to repair, vacate, or demolish said building given by any person authorized by this article to give such notice or order shall be guilty of a misdemeanor and upon conviction thereof shall be fined not exceeding \$100 for each offense and every day subsequent to such notice in which the said owner shall fail to comply with any notice or order as above stated shall be deemed a separate offense.

The occupant or lessee in possession who fails to comply with any notice to vacate and who fails to repair said building in accordance with any notice given as provided for in this article shall be guilty of a misdemeanor and upon conviction thereof shall be fined not exceeding \$100 for each offense and every

day subsequent to such notice in which the said owner shall fail to comply with any notice or order as above stated shall be deemed a separate offense.

Any person removing the notice provided for in § 21-0404, subsection (H) shall be guilty of a misdemeanor and upon conviction shall be fined not exceeding \$100 for each offense.

Source: 1952 Rev. Ord. 21-0406.

21-0407. - Duties of the city attorney.

The city attorney shall:

- A. Prosecute all persons failing to comply with the terms of the notices provided for in § 21-0404, subsections (D) and (E) and the order provided for in § 21-0405, subsection (D).
- B. Appear at all hearings held by the board of city commissioners in regard to "dangerous buildings."
- C. Take such other legal action as is necessary to carry out the terms and provisions of this article.

Source: 1952 Rev. Ord. 21-0407.

21-0408. - Owner absent from the city.

All notices or orders provided for herein shall be sent by certified mail to such owner, occupant, lessee or mortgagee, and all other persons having an interest in said building, to the last known address of each, and a copy of such notice shall be posted in a conspicuous place on the "dangerous building" to which it relates. Such mailing and posting shall be deemed adequate service.

Source: 1952 Rev. Ord. 21-0408, 5121 (2017).

21-0409. - Duties of fire department.

The employees of the fire department shall make a report in writing to the building inspector of all buildings or structures which are, may be, or are suspected to be "dangerous buildings" within the terms of this article. Such reports must be delivered to the building inspector within 24 hours of the discovery of such buildings by any employee of the fire department.

Source: 1952 Rev. Ord. 21-0409.

21-0410. - Duties of the police department.

All employees of the police department shall make a report in writing to the building inspector of any buildings or structures which are, may be, or are suspected to be "dangerous buildings" within the terms of this article. Such reports must be delivered to the building inspector within 24 hours of the discovery of such building by any employee of the police department.

Source: 1952 Rev. Ord. 21-0410.

21-0411. - Duties of the health department.

All employees of the health department shall make a report in writing to the building inspector about any buildings or structures which are, may be, or are suspected to be "dangerous buildings" and which, because of their condition, are untenable, unsanitary, or dangerous to the health, morals, safety, or general welfare of the occupants or the people of this city. Such reports must be delivered within 24 hours of the discovery of such buildings by any employee of the health department.

Source: 1952 Rev. Ord. 21-0411.

21-0412. - Appeal.

The board of city commissioners shall serve upon the owner, occupant, mortgagee, lessee, and all other persons having an interest in any such building so ordered repaired, vacated, or demolished a copy of its order, such notice to be served upon such owner, occupant, mortgagee, or lessee within 10 days after the issuance of such order. Such owner, occupant, mortgagee or lessee shall thereafter have 30 days from the date of the service of such order upon him in which to appeal from such order to the district court of Cass County, North Dakota, or to take such other legal steps to enjoin the enforcement of such order as he may deem proper.

Any person desiring to appeal from any order issued by the board of city commissioners under and by virtue of this article shall file an undertaking in the sum of at least \$500 to be approved by the city auditor and conditioned that the appellant will prosecute the appeal without delay and will pay all costs that may be adjudged against him in the district court. Such undertaking shall be payable to the city of Fargo.

Source: 1952 Rev. Ord. 21-0412.



**GARAAS LAW FIRM**

ATTORNEYS AT LAW

DeMores Office Park

1314 23rd Street South

Fargo, North Dakota 58103

Jonathan T. Garaas  
David Garaas

August 17, 2018

Telephone  
Area Code 701  
293-7211

Fargo City Commission  
Fargo City Hall  
200 3<sup>rd</sup> Street North  
Fargo, North Dakota 58102

HAND DELIVERY

*Attempted at  
4:51 p.m. 1/18  
mailed*

**RE: Hearing on Dangerous Building located at  
427 15<sup>th</sup> Avenue South, Fargo, North Dakota**

Dear Sirs:

I am writing as the attorney for James Peter Sabo, the owner of the following described real property located in Fargo, Cass County, North Dakota:

Lot 113, Belmont Park Addition to the City of Fargo, situate in the County of Cass and the State of North Dakota.

Mr. Sabo indicates that the City of Fargo attempted to hold a "(h)earing on a dangerous building located at 427 15<sup>th</sup> Avenue South" on Monday, August 13, 2018, at 5:15 p.m., at which time he reports an order to demolish his property was issued by unanimous decision of the Fargo City Commission.

In that the laws of North Dakota, and the ordinances of the City of Fargo would not allow such action, there must be some mistake. Let me explain my understanding of applicable law relating to any governmental taking of private property, and while the over-riding legal concept is set forth in the Fourteenth Amendment of the Constitution of the United States, Article I, § 16 of the North Dakota Constitution, and N.D.C.C. Chapter 32-15, I will begin my comments with the process involving nuisances/dangerous buildings under the laws of North Dakota.

In Bergquist v. Eichelberger, 262 N.W.2d 19, 21 (N.D. 1978), it was decided that "a city has the power to order the demolition of private buildings if it enacts an appropriate ordinance pursuant to Section 40-05-02, N.D.C.C., and complies therewith. The City of Fargo enacted such an ordinance, Article 21-04, and it was under that ordinance that the city acted in this case." *Emphasis added.*

According to the documents reviewed by me, the City of Fargo did not comply with either

**EXHIBIT K**

North Dakota's statutory requirements, or Fargo's ordinances.

First, North Dakota's authorization under N.D.C.C. § 40-05-02(23), entitled "Substandard buildings or structures", only extends to three (3) circumstances, none of which are herein presented. This authorizing statute only allows for the demolition, repair, or removal of buildings or structures which (1) "creates a fire hazard", (2) "is dangerous to the safety of the occupants or persons frequenting such premises", or (3) "is permitted by the owner to remain in a dilapidated condition."

Second, the North Dakota statute contains a mandatory due process notice - "Any such ordinance must provide for written notice to the owner of a hearing by the governing body before final action is taken by such body."

Third, the North Dakota statute contains a second mandatory due process requirement - "It (meaning the ordinance) must also provide a reasonable time within which an appeal may be taken by the owner from any final order entered by such governing body to a court of competent jurisdiction."

When applied to the factual and legal circumstances known by James Peter Sabo, possibly all three (3) North Dakota statutory requirements fail to exist. The remodeling efforts of James Peter Sabo have not created a fire hazard, nor are they dangerous to the workmen (there are no occupants), and the remodeling effort is being undertaken so as to avoid any claims of dilapidation.

As to the ordinances of the City of Fargo, it appears that Fargo would probably rely upon FMC Article 21-04 as its process. My initial observation is that FMC § 21-0412, entitled "Appeal" does authorize an "appeal from such order to the district court of Cass County, North Dakota, or to take such other steps to enjoin the enforcement of such order as he may deem proper", such appeal is made contingent upon other things, to include a \$500 undertaking "to be approved by the city auditor and conditioned that the appellant will prosecute the appeal without delay and will pay all costs that may be adjudged against him in the district court. Such undertaking shall be payable to the city of Fargo." Nothing within the State's authorizing statute allows for conditions to be imposed upon the absolute right to appeal to a "court of competent jurisdiction" if that person felt aggrieved by the city's actions.

No written notice of the hearing of August 13, 2018, was ever served upon James Peter Sabo, or anyone having the right to act on his behalf.

As I understand the underlying issues, the City of Fargo has attempted to interfere with James Peter Sabo's remodeling efforts, and has actually voided building permits properly issued to James Peter Sabo, without notice, and while remodeling activities were actually being accomplished. Indeed, Fargo's employees or agents have actually tried to prevent my client from accomplishing appropriate repairs and improvements in a timely manner are allowed by state law.

Perhaps it is appropriate to identify my client's objective, now that he has secured full access to the property after a failed contract for deed arrangement with another individual. Mr. Sabo intends to add trusses to the front of the home so as to increase the available space, and create a new roofed area. The City of Fargo was concerned about the structural integrity of the existing structure, and my client secured the services of Sandman Structural Engineers who investigated the remodeling effort, and on July 5, 2018, identified, in writing, those deficiencies that require remediation. I have attached the July 5, 2018, letter of Kurt Sandman, PE, of Sandman Structural Engineers, along with his drawings and calculations prepared by him on May 24, 2018, and later construction drawings prepared by Wolf Steel Construction, Inc. Sandman Structural Engineers - Exhibit A; construction drawings in Exhibit B. I have also enclosed a 2006 study from Sandman Structural Engineers indicating that the skylight and trusses with load transfers are adequate, and reinforced. There is no known structural inadequacies, and the addition of the steel beam will be sufficient for the intended enhancement on the second floor.

Mr. Sabo indicates that he is willing to comply with each area of deficiency identified by the structural engineer, and he has even purchased the suggested steel beam that must be added to support the second-floor joists. I am enclosing a copy of July 26, 2018, billing statement of Wolf Steel Construction, Inc., showing payment in full for the fabrication of the required steel beams in the amount of \$2,976.68, and also, the quotation from which it originates. Mr. Sabo has been assured the installation of the steel can be accomplished by payment of an additional \$2,000 for labor, which he fully intends to have accomplished if permitted so to do. Wolf Steel Construction, Inc. - Exhibit B; to include construction drawings.

In a similar fashion, James Peter Sabo has indicated to the City of Fargo's own inspectors that he intends to install electrical and plumbing systems meeting all applicable codes, along with new trusses/roof/shingles where construction was to occur, and he spent considerable time going over such requirements with a City of Fargo Inspector prior to initiating the remodeling effort.

Pursuant to permits issued by the City of Fargo, my client, and his laborers were conducting remodeling activities and physically interfered with precluding any additional work. The City of Fargo hired an independent contractor to put up an unsightly chipboard plywood sheet over an entrance, creating great consternation to the neighbors. The roof is intact, and there are no utilities presently being provided to the premises - it is not a fire hazard, nor is it susceptible to flood, mold, or invasive waters. It was being remodeled, so that it could again be occupied by tenants, or by a purchaser. Mr. Sabo should not be condemned for attempting to make improvements to his property.

As to the City of Fargo's ordinances found within Article 21-04, it appears that the City of Fargo has exceeded its authority. As noted above, only three (3) areas of authority with respect to such structure(s) exist, and the municipality is limited with respect to "dangerous" conditions -

allowed only if the structure "is dangerous to the safety of the occupants or persons frequenting such premises".

As to the property at 427 15<sup>th</sup> Avenue South, Fargo, North Dakota, there are no occupants, and any person frequenting such premises with legal authority would be those involved in the remodeling project – either James Peter Sabo, or his employees, agents, or representatives, to include structural engineers and other independent contractors.

When the City of Fargo attempts, at FMC § 21-0401, to define buildings or structures having any one (1), or more of ten (10) definitions as being a "dangerous building, the municipality exceeds the authority granted by the State of North Dakota. The City of Fargo does not have the right to define "dangerous building" so as to dictate what is "dangerous to the safety of the occupants or persons frequenting such premises" – it must actually be dangerous, and when there is no occupants, nor others frequenting the building or structure, such cannot be the basis for this action.

Nor can the City of Fargo create definitions that would be impossible to comply with during the remodeling process (or during first construction), or are so broad to be laughable, such as FMC § 21-0401(10) – I believe that I can state with certainty that every existing building in the City of Fargo will have at least one (1) violation of "any provision of the Building Code, zoning ordinances, any provisions of the Fire Prevention Code or other ordinances of this city." It was extremely amusing when I was once involved in the identification of multiple violations of those codes at a Fargo Fire Station", all displayed with pictures.

My review of the background material for item 44d suggests that the standard utilized by some employees is that of "unsafe" – see Notice of Dangerous Building, ¶s 6 and 7. Such standard is not defined by the ordinance, and all buildings can be "unsafe" at times (if not at all times if people do stupid things). At no place within FMC § 21-0401 is there anything to indicate that a "fifty (50) percent of its original value prior to the damage or deterioration" standard exists for a "dangerous building".

Under FMC § 21-0402(A), if the building "can reasonably be repaired so that it will no longer exist in violation of the terms of this article, it shall be ordered repaired." James Peter Sabo intends to make such repairs, and he certainly has no difficulty agreeing to undertake such repairs so as to comply with applicable code – so long as he is not singled out for unprecedented or unreasonable interpretations of code requirements.

Under FMC § 21-0402(C), there must be a finding that a "dangerous building" exists, before the standard for the appropriate action is implemented. As to value and condition of the property, there is nothing that has occurred in the recent past that gives rise to some 50% rule under either standard – the building is fully capable of being repaired for a reasonable investment; it need not be demolished.

As to other aspects of FMC Article 21-04, it is clear that the building inspector did not comply with the written notice requirements of FMC § 21-0404(D)&(E), and I have been unable to find the “report to the board of city commissioners (of) any noncompliance with the ‘notice’ provided for in subsections (D) and (E) hereof.” In addition, I have been unable to locate any proof of placement of the notice mandated by FMC § 21-0404(H), and note that the postings actually done do not comply with this ordinance’s mandatory requirements.

I have been unable to locate any written notice to the “owner, occupant, mortgagee, lessee and all other persons having an interest in said building as shown by the records of the register of deeds of the county of Cass to appear before (the board of city commissioners) on the date specified in the notice of show cause why the building or structure reported to be a ‘dangerous building’ should not be repaired, vacated, or demolished in accordance with the statement of particulars set forth in the building inspector(s) notice provided for herein in § 21-0404, subsection (E).”

It obvious that the board of city commissioners cannot hold a hearing without the required service of the order to show cause required by the ordinance, so non-compliance with FMC § 21-0405(B) is presumed. Further, my client advises me that he was not allowed to address the board, nor introduce documents that support his position, and also, neighbors were allowed to vent anger, some of which should be addressed to remedial actions taken by the city of Fargo’s employees or independent contractors. According to the ordinance, only “the building inspector or the owner, occupant, mortgagee, lessee or any other person having an interest in said building as shown by the records of the register of deeds of the county of Cass shall offer (testimony) relative to the ‘dangerous building.’” *Id.*

So far as is known to me, no “written findings of fact from the testimony offered” now exist, a clear violation of FMC § 21-0405(C).

Similarly, so far as is known to me, there is no written “order based upon findings of fact made pursuant to subsection (C) hereof commanding the owner, occupant, mortgagee, lessee, and all other persons having an interest in said building as shown by the records of the register of deeds of the county of Cass to repair, vacate, or demolish any building found to be a ‘dangerous building’ within the terms of this article and provided that any person so notified, except the owners, shall have the privilege of either vacating or repairing said ‘dangerous building.’” This ordinance mandates the right of vacating or repairing, and any attempt to preclude the owner from doing so is a violation of the equal protection of the law under known constitutional standards – moreover, such ordinance is nonsensical. My client most assuredly will make sure there is a lessee that can avail himself of the right of repair should it ever come to that. There is no reason not to repair this property, and it will be done to existing standards.

Until the existence of a proper order, along with compliance with due process of law,<sup>1</sup> the board of city commissioners is not in a position to “cause such building or structure to be repaired, vacated, or demolished as the facts may warrant” – obviously there would have to be another evidentiary hearing to ascertain the circumstances to implement FMC § 21-0405(E) and (F), and equally assured, the repairs are going to take more than ten (10) days. It is incumbent upon the board of city commissioners to create a reasonable period of time for the repairs. My client assures me that all will be accomplished by January 1, 2019.

Please be aware that non-compliance with due process of law amounts to a “taking” for which just compensation is always required as a matter of law, of constitutional dimensions. James Peter Sabo asks for a reasonable time to accomplish the necessary repairs, which requires issuance of proper permits to allow access and construction. See, Blanchard v. City of Ralston, 559 N.W.2d 735 (Nebr. 1997) for a discussion of applicable concepts should Mr. Sabo be denied meaningful notice of the alleged dangers and opportunity to remedy any deficiencies, and defend his case.

Please acknowledge the intent of the City of Fargo to abandon the course of action verbally directed on Monday, August 13, 2018, and issue appropriate permits so that Mr. Sabo can accomplish necessary repairs. He pledges completion to the reasonable expectations of all applicable code requirements by January 1, 2019, and he is willing to pay appropriate permit charges.

May we hear from you please?

Very truly yours,

Jonathan T. Garaas

JTG:j  
Enclosures

---

<sup>1</sup> FMC § 21-0408 requires certified mail, along with a posting in a conspicuous place. As previously mentioned, no posting contained the mandatory language required by ordinance, and no certified mailings with the appropriate notices have ever occurred. While a document entitled “Notice of Dangerous Building” was sent by certified mail on June 26, 2018, it did not contain the information required by FMC § 21-0404(D) & (E), and James Peter Sabo attempted to comply with the “actions (that) must be taken”, but was prevented from doing so by voiding issued building permits, and apparent refusal to accept or automatic rejection of whatever was presented. A meaningful opportunity to act must exist, and the city should not countenance anyone being subjected to a process that is impossible to honor.



**SANDMAN**  
Structural Engineers

July 5, 2018

Pete Sabo  
1221 9<sup>th</sup> Ave N  
Fargo, ND 58102

RE: 427 15<sup>th</sup> Ave S, Fargo ND

Sandman Structural Engineers (SSE) was retained to review the property at 427 15<sup>th</sup> Avenue South, Fargo, ND. The purpose of the visit was to review the residence which is currently being remodeled and provide opinion as to what areas need attention. A site visit was made on 7/2/18 to review the current progress and condition of the property. The list below identifies the items discussed during the site visit as deficient that require remediation.

Observations:

**1. Main Floor Openings/Headers**

a. Current Condition:

- i. The original construction did not utilize headers above the main floor window or door openings.

b. Recommendation:

- i. Due to the additional level, new (2)-2x8 headers must be added to the openings on the main floor to support the loads from above. The opening framing also needs to have one additional king stud added to each supporting end of the opening.

**2. Interior Beam**

a. Current Condition:

- i. There is lack of interior bearing support for the second-floor joists.

b. Recommendation:

- i. A new W12x26 steel beam must be added to support the second-floor joists. This steel beam shall have a 2x6 wood plate bolted to the top flange and the second-floor joists shall have full bearing on the beam. The south end of the steel beam shall be supported by an HSS 3x3x 3/16 steel column down to the basement slab level and rest on a new 30" square footing. The north end of the beam will have a W12x26 transfer beam to allow for the stair opening below. Each end of the transfer is to be supported by an HSS 3x3x 3/16 steel column down to the basement slab level and rest on a new 24" square footing. The steel fabricator to provide shop drawings for review.

**EXHIBIT A**



**3. Second Floor Joists**

a. Current Condition:

- i. The second-floor joists are inconsistent and have discontinuous members and members with notches and holes in them. Several plies have been added in attempt to make a continuous floor joist. There are also existing floor penetrations that were part of the framing that were infilled.

b. Recommendation:

- i. The existing laminated floor joists must be abandoned, and a new continuous un-notched joist be added in each location that there is not a true continuous un-notched member. The new joists must bear on the exterior wall a minimum of 3" and have full bearing on the new steel beam line supporting the interior bearing location. The existing floor penetrations must be removed to allow for continuous joists to span from the exterior wall to the interior beam.

**4. Existing Second Floor Piping**

a. Current Condition:

- i. There is second level bathroom piping that has been run through second floor joists.

b. Recommendation:

- i. This piping must be removed and placed in a chase or below the framing, so joists will not be cut, or holes bored in them.

**5. Upper Stair Bearing Wall**

a. Current Condition:

- i. There is new bearing wall installed to support shortened second-floor joists at the stair location. This wall bears on the first-floor joists.

b. Recommendation:

- i. If this wall is to remain, a bearing wall must be placed below the first-floor joists directly under this wall supported by the basement slab as the first-floor joists cannot support a bearing wall.

**6. Foundation Walls**

a. Current Condition:

- i. There are wide horizontal cracks in the foundation wall as a result of inward movement due to the active soil pressure.

b. Recommendation:

- i. New W4x13 vertical steel braces should be placed on either side of basement window locations and otherwise spaced at 6'-0" on center all around the basement foundation. These braces shall be grouted in at the base and properly blocked in to the floor framing at the first floor with bolted blocking. The braces shall be in contact with the wall and the gap shall be grouted solid with non-shrink grout.

**7. Second Floor Sub-Floor**

a. Current Condition:

- i. There are areas of non-uniform sub-flooring on the second level.

b. Recommendation:



- i. Continuous 3/4" tongue and groove sub-flooring shall be nailed and glued to the second-floor joists. Filler plywood may be used below the 3/4" sub-floor if it is competent non-degraded plywood to make up any elevation differential.

SSE appreciates the opportunity to provide this evaluation and recommendations. If you have any questions, please feel free to call at any time.

Thank you,



Kurt Sandman, PE  
Owner/Principal



PROJ. # \_\_\_\_\_ DATE 5.24.18 BY KS PAGE \_\_\_\_\_  
 HOUSE BEAM  
 PETE SABO 427 15TH AVE S

FLOOR LOADS

LIVE LOAD = 40 psf  
 DEAD LOAD = 20 psf

Ⓢ FIRST FLOOR LOADS ONLY  
 UPPER LEVEL CLEARSPANS

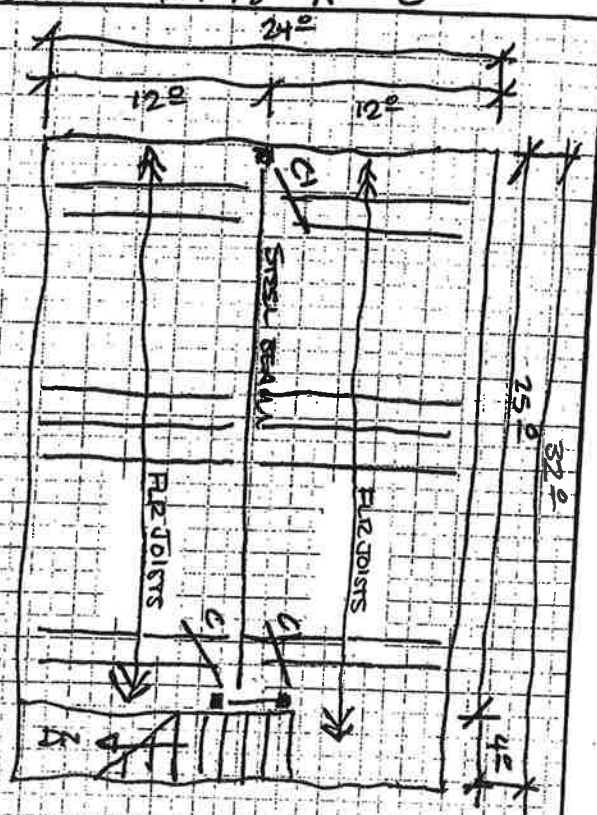

BEAM DESIGN

$W_1 = 40 \text{ psf} (12) = 480 \text{ lb} \rightarrow U$   
 $20 \text{ psf} (12) = 240 \text{ lb} \rightarrow DL$   
 $R_{U1} = 9.4 \text{ k}$

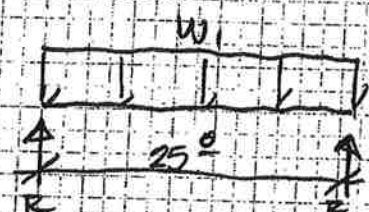

→ USE: W12X26  $U = .63$   $\delta = 1.13"$   $1/269$   
W14X22  $U = .70$   $\delta = 1.14"$   $1/264$

\* PUNCH HOLES IN TOP FLANGE FOR WOOD PLATES

COLUMN DESIGN

$l = 8'$   $P = 9.4 \text{ k}$

USE HSS 3X3X3/16  $P_{AU} = 28.5 \text{ k}$  OK

- 1/2" CAP PL W/ (2) - 5/8 BOLTS
- 1/2" X 8" X 8" BASE PL W/ (4) - 5/8 EXP BOLTS

FOOTING DESIGN

$P = 9.4 \text{ k}$   
 $Q_{ALL} = 1500 \text{ psf}$

$A_F = \frac{9400 \text{ lbs}}{1500 \text{ psf}} \approx 6.3 \text{ SF}$

ONE END BEARS ON FON WALL W/ CORBELING WILL ENGAGE 10.5 SF OF FTG - OK.  
 THE OTHER END WILL HAVE TRANSFER BEAM W/ 2 POSTS SO LOAD @ EACH POST IS 4.7 k, 4" SLAB ADEQUATE TO SUPPORT THIS LOAD - OK

**Steel Beam**

Lic. #: KW-06008681

File = C:\Users\TMGLE-1\SS\Desktop\KS.sc6  
 ENERCALC, INC. 1883-2017, Build:10.17.7.24, Ver:10.17.7.24  
 Licensee : Sandman Consulting, PC

Description : 427 15th Ave S - 25' span

**12" STEEL BEAM OPTION**

**CODE REFERENCES**

Calculations per AISC 360-10, IBC 2015, ASCE 7-10  
 Load Combination Set : IBC 2015

**Material Properties**

Analysis Method : Allowable Strength Design  
 Beam Bracing : Beam is Fully Braced against lateral-torsional buckling  
 Bending Axis : Major Axis Bending  
 Fy : Steel Yield : 50.0 ksi  
 E : Modulus : 29,000.0 ksi

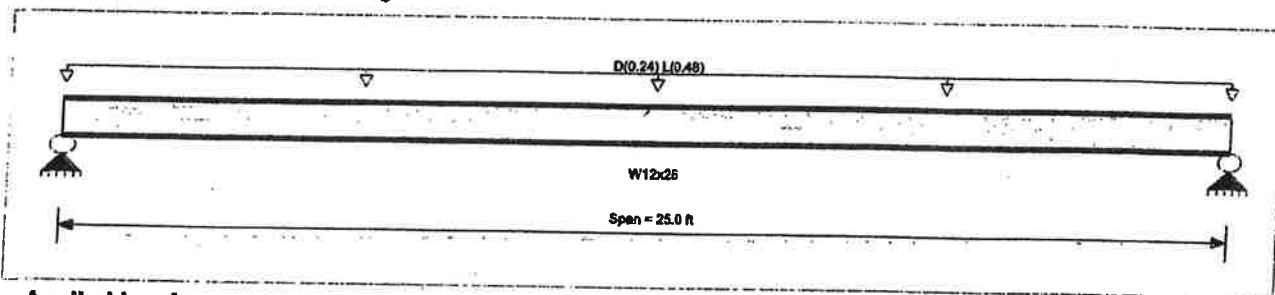

**Applied Loads**

Service loads entered. Load Factors will be applied for calculations.

Beam self weight calculated and added to loading  
 Uniform Load : D = 0.240, L = 0.480 k/ft, Tributary Width = 1.0 ft

**DESIGN SUMMARY**

		Design OK	
Maximum Bending Stress Ratio =	0.628 : 1	Maximum Shear Stress Ratio =	0.166 : 1
Section used for this span	W12x26	Section used for this span	W12x26
Ma : Applied	58.281 k-ft	Va : Applied	9.325 k
Mn / Omega : Allowable	92.814 k-ft	Vn/Omega : Allowable	56.120 k
Load Combination	+D+L+H	Load Combination	+D+L+H
Location of maximum on span	12.500ft	Location of maximum on span	0.000 ft
Span # where maximum occurs	Span # 1	Span # where maximum occurs	Span # 1
Maximum Deflection			
Max Downward Transient Deflection	0.716 in Ratio = 418 >= 360		
Max Upward Transient Deflection	0.000 in Ratio = 0 < 360		
Max Downward Total Deflection	1.113 in Ratio = 269 >= 240.0		
Max Upward Total Deflection	0.000 in Ratio = 0 < 240.0		

**Maximum Forces & Stresses for Load Combinations**

Load Combination	Segment Length	Span #	Max Stress Ratios		Summary of Moment Values						Summary of Shear Values			
			M	V	Mmax +	Mmax -	Ma Max	Mrx	Mnx/Omega	Cb	Rm	Va Max	Vnx	Vnx/Omega
+D+H	Dsgn. L = 25.00 ft	1	0.224	0.059	20.78		20.78	155.00	92.81	1.00	1.00	3.33	84.18	56.12
+D+L+H	Dsgn. L = 25.00 ft	1	0.628	0.166	58.28		58.28	155.00	92.81	1.00	1.00	9.33	84.18	56.12
+D+Lr+H	Dsgn. L = 25.00 ft	1	0.224	0.059	20.78		20.78	155.00	92.81	1.00	1.00	3.33	84.18	56.12
+D+S+H	Dsgn. L = 25.00 ft	1	0.224	0.059	20.78		20.78	155.00	92.81	1.00	1.00	3.33	84.18	56.12
+D+0.750Lr+0.750L+H	Dsgn. L = 25.00 ft	1	0.527	0.139	48.91		48.91	155.00	92.81	1.00	1.00	7.83	84.18	56.12
+D+0.750L+0.750S+H	Dsgn. L = 25.00 ft	1	0.527	0.139	48.91		48.91	155.00	92.81	1.00	1.00	7.83	84.18	56.12
+D+0.60W+H	Dsgn. L = 25.00 ft	1	0.224	0.059	20.78		20.78	155.00	92.81	1.00	1.00	3.33	84.18	56.12
+D+0.70E+H	Dsgn. L = 25.00 ft	1	0.224	0.059	20.78		20.78	155.00	92.81	1.00	1.00	3.33	84.18	56.12
+D+0.750Lr+0.750L+0.450W+H	Dsgn. L = 25.00 ft	1	0.527	0.139	48.91		48.91	155.00	92.81	1.00	1.00	7.83	84.18	56.12
+D+0.750L+0.750S+0.450W+H	Dsgn. L = 25.00 ft	1	0.527	0.139	48.91		48.91	155.00	92.81	1.00	1.00	7.83	84.18	56.12
+D+0.750L+0.750S+0.5250E+H	Dsgn. L = 25.00 ft	1	0.527	0.139	48.91		48.91	155.00	92.81	1.00	1.00	7.83	84.18	56.12
+0.60D+0.60W+0.60H	Dsgn. L = 25.00 ft	1	0.134	0.036	12.47		12.47	155.00	92.81	1.00	1.00	2.00	84.18	56.12

**Steel Beam**

Lic. #: KW-06008681

File = C:\Users\TIMKLE-1.SSE\Desktop\KS.ac6  
 ENERCALC, INC. 1983-2017, Build:10.17.7.24, Ver:10.17.7.24

Description: 427 15th Ave S - 25' span

Licensee: Sandman Consulting, PC

Load Combination	Segment Length	Span #	Max Stress Ratios		Summary of Moment Values						Summary of Shear Values			
			M	V	Mmax +	Mmax -	Ma Max	Mnx	Mnx/Omega	Cb	Rm	Va Max	Vnx	Vnx/Omega
Dsgn. L = 25.00 ft		1	0.134	0.036	12.47		12.47	155.00	92.81	1.00	1.00	2.00	84.18	56.12

**Overall Maximum Deflections**

Load Combination	Span	Max. "+" Defl	Location in Span	Load Combination	Max. "+" Defl	Location in Span
+D+L+H	1	1.1134	12.571		0.0000	0.000

**Vertical Reactions**

Load Combination	Support notation: Far left is #1	
	Support 1	Support 2
Overall MAXimum	9.325	9.325
Overall MINimum	1.995	1.995
+D+H	3.325	3.325
+D+L+H	9.325	9.325
+D+Lr+H	3.325	3.325
+D+S+H	3.325	3.325
+D+0.750Lr+0.750L+H	7.825	7.825
+D+0.750L+0.750S+H	7.825	7.825
+D+0.60W+H	3.325	3.325
+D+0.70E+H	3.325	3.325
+D+0.750Lr+0.750L+0.450W+H	7.825	7.825
+D+0.750L+0.750S+0.450W+H	7.825	7.825
+D+0.750L+0.750S+0.5250E+H	7.825	7.825
+0.60D+0.60W+0.60H	1.995	1.995
+0.60D+0.70E+0.60H	1.995	1.995
D Only	3.325	3.325
Lr Only		
L Only	6.000	6.000
S Only		
W Only		
E Only		
H Only		

**Steel Beam**

Lic. #: KW-06008681

Description: 427 15th Ave S - 25' span (W14 Option)

File = C:\Users\THAGLE-1\SSE\Desktop\KS.ac6  
 ENERCALC, INC. 1988-2017, Build:10.17.7.24, Ver:10.17.7.24  
 Licensee: Sandman Consulting, PC

**CODE REFERENCES**

Calculations per AISC 360-10, IBC 2015, ASCE 7-10  
 Load Combination Set: IBC 2015

**14" STEEL BEAM OPTION**

**Material Properties**

Analysis Method: Allowable Strength Design  
 Beam Bracing: Beam is Fully Braced against lateral-torsional buckling  
 Bending Axis: Major Axis Bending

Fy: Steel Yield: 50.0 ksi  
 E: Modulus: 29,000.0 ksi

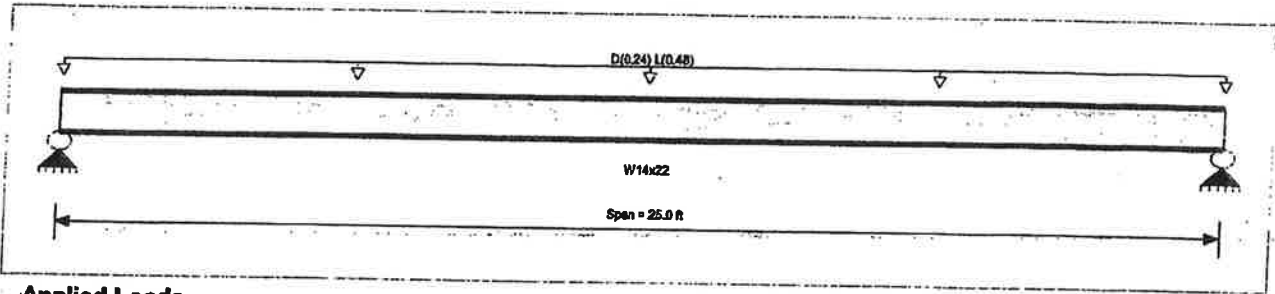

**Applied Loads**

Service loads entered. Load Factors will be applied for calculations.

Beam self weight calculated and added to loading  
 Uniform Load: D = 0.240, L = 0.480 k/ft, Tributary Width = 1.0 ft

**DESIGN SUMMARY**

Design OK

Maximum Bending Stress Ratio = Section used for this span	<b>0.700 : 1</b> <b>W14x22</b>	Maximum Shear Stress Ratio = Section used for this span	<b>0.147 : 1</b> <b>W14x22</b>
Ma: Applied	57.969 k-ft	Va: Applied	9.275 k
Mn / Omega: Allowable	82.834 k-ft	Vn / Omega: Allowable	63.020 k
Load Combination	+D+L+H	Load Combination	+D+L+H
Location of maximum on span	12.500ft	Location of maximum on span	0.000 ft
Span # where maximum occurs	Span # 1	Span # where maximum occurs	Span # 1
Maximum Deflection			
Max Downward Transient Deflection	0.734 in Ratio = 408 >= 360		
Max Upward Transient Deflection	0.000 in Ratio = 0 < 360		
Max Downward Total Deflection	1.135 in Ratio = 264 >= 240.		
Max Upward Total Deflection	0.000 in Ratio = 0 < 240.0		

**Maximum Forces & Stresses for Load Combinations**

Load Combination	Segment Length	Span #	Max Stress Ratios		Summary of Moment Values						Summary of Shear Values			
			M	V	Mmax +	Mmax -	Ma Max	Mnx	Mnx/Omega	Cb	Rm	Va Max	Vnx	Vnx/Omega
+D+H	Dsgn. L = 25.00 ft	1	0.247	0.052	20.47		20.47	138.33	82.83	1.00	1.00	3.28	94.53	63.02
+D+L+H	Dsgn. L = 25.00 ft	1	0.700	0.147	57.97		57.97	138.33	82.83	1.00	1.00	9.28	94.53	63.02
+D+Lr+H	Dsgn. L = 25.00 ft	1	0.247	0.052	20.47		20.47	138.33	82.83	1.00	1.00	3.28	94.53	63.02
+D+S+H	Dsgn. L = 25.00 ft	1	0.247	0.052	20.47		20.47	138.33	82.83	1.00	1.00	3.28	94.53	63.02
+D+0.750Lr+0.750L+H	Dsgn. L = 25.00 ft	1	0.587	0.123	48.59		48.59	138.33	82.83	1.00	1.00	7.78	94.53	63.02
+D+0.750L+0.750S+H	Dsgn. L = 25.00 ft	1	0.587	0.123	48.59		48.59	138.33	82.83	1.00	1.00	7.78	94.53	63.02
+D+0.60W+H	Dsgn. L = 25.00 ft	1	0.247	0.052	20.47		20.47	138.33	82.83	1.00	1.00	3.28	94.53	63.02
+D+0.70E+H	Dsgn. L = 25.00 ft	1	0.247	0.052	20.47		20.47	138.33	82.83	1.00	1.00	3.28	94.53	63.02
+D+0.750Lr+0.750L+0.450W+H	Dsgn. L = 25.00 ft	1	0.587	0.123	48.59		48.59	138.33	82.83	1.00	1.00	7.78	94.53	63.02
+D+0.750L+0.750S+0.450W+H	Dsgn. L = 25.00 ft	1	0.587	0.123	48.59		48.59	138.33	82.83	1.00	1.00	7.78	94.53	63.02
+D+0.750L+0.750S+0.5250E+H	Dsgn. L = 25.00 ft	1	0.587	0.123	48.59		48.59	138.33	82.83	1.00	1.00	7.78	94.53	63.02
+0.60D+0.60W+0.60H	Dsgn. L = 25.00 ft	1	0.148	0.031	12.28		12.28	138.33	82.83	1.00	1.00	1.97	94.53	63.02
+0.60D+0.70E+0.60H	Dsgn. L = 25.00 ft	1	0.148	0.031	12.28		12.28	138.33	82.83	1.00	1.00	1.97	94.53	63.02

**Steel Beam** File = C:\Users\TMGLE-1\SS\Desktop\KS.ec6  
ENERCALC, INC. 1983-2017, Build:10.17.7.24, Ver:10.17.7.24  
Licensee : Sandman Consulting, PC  
 Lic. #: KW-06008681  
 Description: 427 15th Ave S - 25' span (W14 Option)

Load Combination	Segment Length	Span #	Max Stress Ratios		Summary of Moment Values						Summary of Shear Values			
			M	V	Mmax +	Mmax -	Ma Max	Mnx	Mnx/Omega Cb	Rn	Va Max	Vrx	Vrx/Omega	
Dsgn. L = 25.00 ft		1	0.148	0.031	12.28		12.28	138.33	82.83	1.00	1.00	1.97	94.53	63.02

**Overall Maximum Deflections**

Load Combination	Span	Max. "-" Defl	Location in Span	Load Combination	Max. "+" Defl	Location in Span
+D+L+H	1	1.1352	12.571		0.0000	0.000

**Vertical Reactions**

Load Combination	Support notation : Far left is #1		Values in KIPS
	Support 1	Support 2	
Overall MAXimum	9.275	9.275	
Overall MINimum	1.965	1.965	
+D+H	3.275	3.275	
+D+L+H	9.275	9.275	
+D+L+H	3.275	3.275	
+D+S+H	3.275	3.275	
+D+0.750L+0.750L+H	7.775	7.775	
+D+0.750L+0.750S+H	7.775	7.775	
+D+0.60W+H	3.275	3.275	
+D+0.70E+H	3.275	3.275	
+D+0.750L+0.750L+0.450W+H	7.775	7.775	
+D+0.750L+0.750S+0.450W+H	7.775	7.775	
+D+0.750L+0.750S+0.5250E+H	7.775	7.775	
+0.60D+0.60W+0.60H	1.965	1.965	
+0.60D+0.70E+0.60H	1.965	1.965	
D Only	3.275	3.275	
Lr Only			
L Only	6.000	6.000	
S Only			
W Only			
E Only			
H Only			

### Column on Slab

**Project Name**      427 15th Ave  
**Project #**  
**Calc ID:**            Point Load at Transfer Post  
**Solving For:**       Existing Slab Check  
**Date:**                6/20/2018

#### INPUT

$P_u$  = Factored column load                      6345 lb  
 $f_c$  =    3000  
 $k$  =    100 pci  
 $b$  = base plate dimension                      7.5 in  
 $LF$  =    1.55 Conversion Between Service and Ultimate  
 $t$  = Slab thickness                                      4 in

#### VARIABLES

A    0.000548  
B    50116614.0  
C    316406.25

#### RESULTS

##### Allowable Load ( $P_{all}$ )

$P_u$  =    7292 lbs  
 $P_{all}$  =    4705 lbs

4.70 k      OK

\*to solve for Load, do not input  $P_u$  above

##### Required Slab Thickness (t)

$t_1$  =    16  
 $t_2$  =    13.921761

\*to solve for t, input  $P_u$  and adjust t above until  $t_1$  and  $t_2$  match





**SANDMAN**  
Structural Engineers

PROJ. #

DATE

BY

PAGE

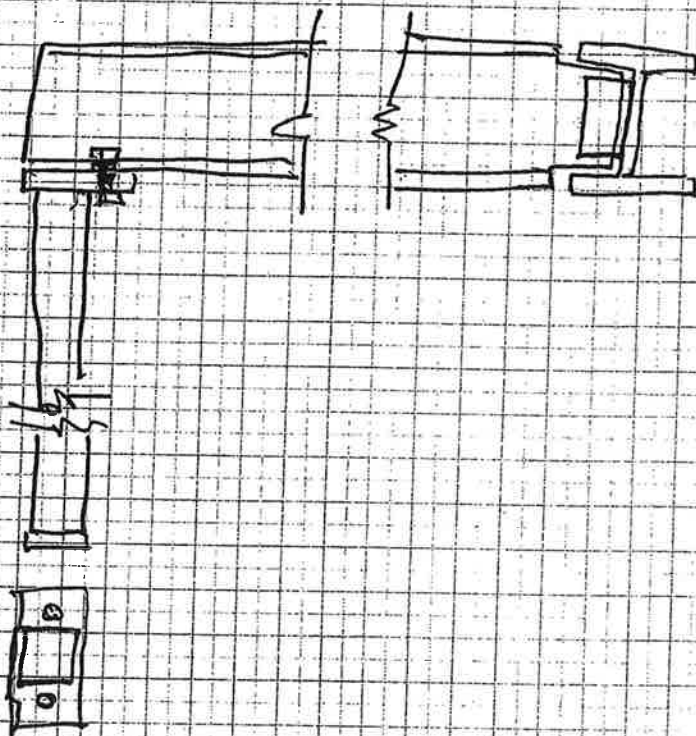



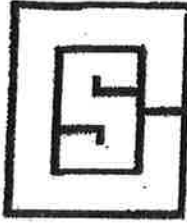

**SANDMAN CONSULTING PC  
STRUCTURAL ENGINEERING**

810 4th AVENUE SOUTH SUITE 106  
MOORHEAD MN 56560  
PH 218-227-0022 FX 218-227-0024  
email: kurt@sandmanconsultingpc.com

**FAX**

**Date:** 10/25/06 4:19 PM

**To:** Pete Sabo

**Company:**

**Fax #:** 237-6231

**Cc:** File

**From:** Kurt Sandman

**# of Pages:** 3

**RE:** 427 15th AVE So.

Message:

Pete,

Please find the requested information on the residence at 427 15th AVE S. Fargo.

Please call if you have any questions.

Thank you,

Kurt Sandman, PE  
Owner / Principal

NOTICE: This electronic communication and attachments are privileged to the sender and to the intended recipient. If you have erroneously received this e-mail please advise Sandman Consulting PC and delete the communication and attachments. If you are not the intended recipient any use, redistribution, modification, copying, or any action taken is prohibited. The unauthorized use relieves Sandman Consulting PC from any liability for use of information. Thank you.

From: Sandman Consulting, PC

2182270024

10/25/2006 16:21 #034 P.002/003

1

Pete Sabo  
1221 9th AVE N.  
Fargo, ND 58102

10/25/06



**SANDMAN CONSULTING PC  
STRUCTURAL ENGINEERING**

610 4th AVENUE SOUTH SUITE 106  
MOORHEAD MN 56560  
PH 218-227-0022 FX 218-227-0024

RE: 427 15th Ave So.  
Fargo, ND  
Roof Truss Evaluation

Pete,  
Sandman Consulting PC (SCPC) was retained to evaluate the capacity of the adjacent trusses to a skylight opening at the said residence. The purpose of the analysis is due to the fact the one truss at the skylight has been cut and its loads transferred to the adjacent trusses. A site visit was made on Tuesday October 24th, 2006.

Description

The header location of the truss is approximately six feet from the east end of the truss. The load is transferred to the bottom chord via a combination of headers and joist hangers. This load transfer is adequate. Once the load is delivered to the adjacent trusses, overstresses occur and build up of the existing adjacent trusses is required.

Reinforcement

The reinforcement of the trusses adjacent to the skylight can be viewed on attached 1. This truss reinforcement detail consists of adding a vertical 2x4 from point of load transfer on the bottom chord, up nearest the top chord panel point. This 2x4 vertical web, ends beveled for slope, shall be SPF No.1 and fastened at each end with 2x4 gang nail plates each side. Additionally, the top and bottom chord shall have a 2x4 x 10'-0 (centered at the point of load transfer) added using 16d common nails at 3" o.c. The chord reinforcement shall be SPF No. 1 as well.

SCPC appreciates the opportunity to provide its services. If you have any questions feel free to call at any time.

Sincerely,

Kurt Sandman PE  
Owner/Principal

Cc: File

Att: 1



**TRUSS ELEVATION**

- (A) — 2x4 VERT. (SPE. NO. 1) FASTEN FROM PT OF LOAD UP TO NEAREST PANEL POINT SEE BELOW.
- (B) — 2x4 K1010 (SPE. NO. 1) TOP CHORD REINFORCEMENT FASTEN w/ 1/4" COMBOS @ 6" O.C.
- (C) — 2x4 X 1010 (SPE. NO. 1) BOTTOM CHORD REINFORCEMENT FASTEN w/ 1/4" COMBOS @ 3" O.C.

2x4 GANG NAIL @ EX SIDE TRS.

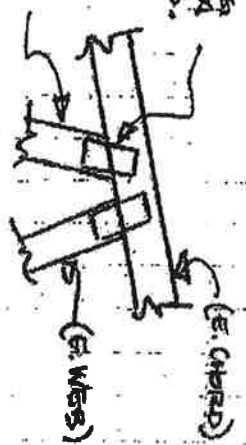

NEW WERS CORR.

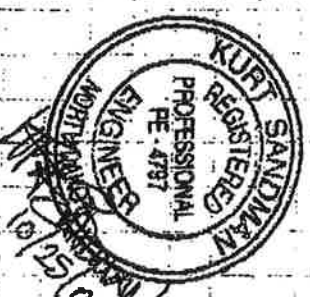

Designed by: <b>KS</b> Job Title: _____ Date: 10/25/06 Prof. # 0601 PP	Scale: _____ Sheet: 11 of _____ TRUSS REINF.	SANDMAN CONSULTING PC STRUCTURAL ENGINEERING 810 FOURTH AVENUE SOUTH, SUITE 106 WOODHAD, NC 28560 PH 218-227-0022 FAX 218-227-0024 contact@sandmanconsultingpc.com
---	--	---

Wolf Steel Construction Inc.

1408 2nd Ave North  
Fargo, ND 58102

# Invoice

Date	Invoice #
7/26/2018	9294

**Bill To**  
Pete Sabo

**PAID**  
07/28/2018

**Ship To**

P.O. Number	Terms	Rep	Ship	Via	F.O.B.	Project
	Due on receipt		7/26/2018			

Quantity	Item Code	Description	Price Each	Amount
1	Fabrication	Materials Only- 2 beams , 3 columns primed. 1 field measure trip Jobsite delv. Sales Tax	2,769.00	2,769.00T
			7.50%	207.68

**EXHIBIT B**

Bless Our Friends "Indeed"

**Phone #**  
7012396968

**E-mail**  
DONNA@WOLFSTEEL.COM

**Total**  
Web Site \$2,976.68  
www.wolfsteel.com



1408 2nd Avenue North • Fargo, North Dakota 58102

Office: 701-239-6968 • Fax: 701-232-1099 • E-mail: [Curtis@wolfsteel.com](mailto:Curtis@wolfsteel.com) • [www.wolfsteel.com](http://www.wolfsteel.com)

July 2, 2018

To: Pete Sabo

Regards to: House Beam  
Fargo, ND

Based on the drawings dated 5/24/18, I have determined that we will supply the materials for the items listed below. **Base off from Sandman Structural drawings only.**

**Base Bid:**

**Materials only**

- 1. 05 1200 Structural Steel
  - 2 – Beams
    - i. Primed
  - 3 – Columns
    - i. Primed
    - ii. Base and Top Plates
  - 1 – Field Measurement Trip
  - Job Site Delivery (Fargo, ND)

**Total: \$2,769.00 Plus tax**

**Exclusions:**

- (1) Taxes
- (2) Unloading, Installation, & Erection (Erection will bid separate)
- (3) Touchup paint, galvanizing repair, and field painting
- (4) Shoring of any kind
- (5) Grout and grouting
- (6) Engineering or design work of any kind
- (7) Expansion joint covers and column wraps covers
- (8) Access doors or panels
- (9) Deck supports at small openings and/or around columns (unless specifically included above)

- (10) Plate 1/8" (10 Ga.) or lighter unless specifically included, & Pre-engineered metal framing
- (11) Field planning, field measuring, field surveys, or as-built surveys
- (12) Finish paint systems
- (13) AISC certified shop
- (14) All Aluminum and Stainless Steel
- (15) Bolts and supports for other trades, wood to Steel Fasteners
- (16) All steel shown on Electrical, Mechanical, and Plumbing Drawings
- (17) Items not sized or specified on drawings
- (18) All special inspection costs, or per-diems from an outside inspector or agency
- (19) Rebar, rebar couplers, and welding of the same to structural steel
- (20) Supply and install of DBA's
- (21) Unistrut materials of any kind

**Qualifications:**

- 1. Price is F.O.B Jobsite
- 2. All schedules must be mutually agreed upon by the customer and Wolf Steel Construction – Delivery schedule to be determined
- 3. No back charges will be accepted without Wolf Steel Construction's written acceptance of the back charge prior to commencement of the work
- 4. All work to be performed in a standard 40 hour work week
- 5. Price based on no retainage, penalties, or liquidated damages
- 6. Stairs to be supplied broken down – not in assemblies
- 7. The drawings are owned by Wolf Steel Construction and is not to be shared with others for manufacturing purposes.
- 8. Wolf Steel Construction reserves the right to review material pricing and adjust per market conditions.
- 9. No "pay if paid" or "pay when paid" terms to be accepted
- 10. Cash or net 30 days for customers with Pre-Approved Credit. Interest will be charged on past due accounts
- 11. Payment for fabricated and un-fabricated materials that are suitably stored and assured in our yard is required
- 12. Paint: One coat standard gray shop primer
- 13. Cleaning: Hand Tool/SSPC-SP2

We acknowledge (0) addendums

This bid is good for 15 calendar days.

Terms: This proposal document, as amended by mutual agreement, shall become a part of the subcontract agreement. NET 30, No Retainage allowed, 18% annual rate on unpaid balance, plus collection fees.

Respectfully Yours,

*Curtis L Pederson*

Curtis L Pederson

Estimator

Project Name: House Beam – Pete Sabo      Date: July 2, 2018

NOTE: CONTRACT MUST BE SIGNED BEFORE MATERIAL CAN BE ORDERED. Acceptance of this proposal constitutes acceptance of Wolf Steel Construction's Standard Terms and Conditions.

Accepted:

*Pete Sabo*

Company Name

Signature

Print Name & Title

Date

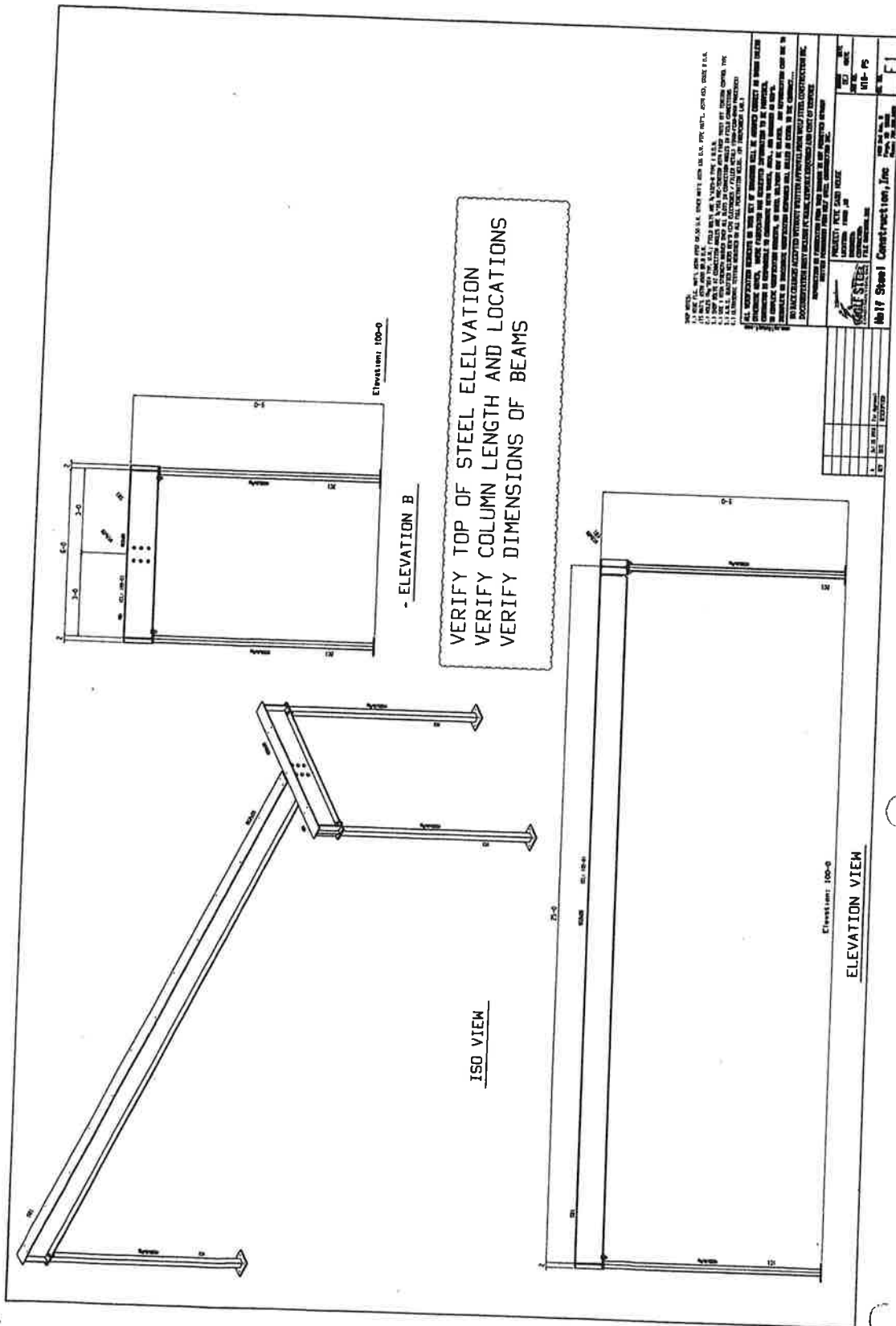

**NOTES:**

1. ALL DIMENSIONS ARE TO FACE UNLESS NOTED OTHERWISE.
2. ALL DIMENSIONS ARE TO CENTER UNLESS NOTED OTHERWISE.
3. ALL DIMENSIONS ARE TO CENTER UNLESS NOTED OTHERWISE.
4. ALL DIMENSIONS ARE TO CENTER UNLESS NOTED OTHERWISE.
5. ALL DIMENSIONS ARE TO CENTER UNLESS NOTED OTHERWISE.
6. ALL DIMENSIONS ARE TO CENTER UNLESS NOTED OTHERWISE.
7. ALL DIMENSIONS ARE TO CENTER UNLESS NOTED OTHERWISE.
8. ALL DIMENSIONS ARE TO CENTER UNLESS NOTED OTHERWISE.
9. ALL DIMENSIONS ARE TO CENTER UNLESS NOTED OTHERWISE.
10. ALL DIMENSIONS ARE TO CENTER UNLESS NOTED OTHERWISE.

**ALL DIMENSIONS ARE TO CENTER UNLESS NOTED OTHERWISE.**

ALL DIMENSIONS ARE TO CENTER UNLESS NOTED OTHERWISE.

ALL DIMENSIONS ARE TO CENTER UNLESS NOTED OTHERWISE.

ALL DIMENSIONS ARE TO CENTER UNLESS NOTED OTHERWISE.

ALL DIMENSIONS ARE TO CENTER UNLESS NOTED OTHERWISE.

ALL DIMENSIONS ARE TO CENTER UNLESS NOTED OTHERWISE.

ALL DIMENSIONS ARE TO CENTER UNLESS NOTED OTHERWISE.

ALL DIMENSIONS ARE TO CENTER UNLESS NOTED OTHERWISE.

ALL DIMENSIONS ARE TO CENTER UNLESS NOTED OTHERWISE.

ALL DIMENSIONS ARE TO CENTER UNLESS NOTED OTHERWISE.

PROJECT: FINE... [illegible]		
CONTRACTOR: [illegible]		
DATE: [illegible]	SCALE: [illegible]	BY: [illegible]
NO.	DATE	DESCRIPTION
APPROVED FOR CONSTRUCTION: [illegible]		
APPROVED FOR [illegible]: [illegible]		
APPROVED FOR [illegible]: [illegible]		
APPROVED FOR [illegible]: [illegible]		



(1-HSS3x3x1/2-10)MSK 7-110kg (P/P 3-0)

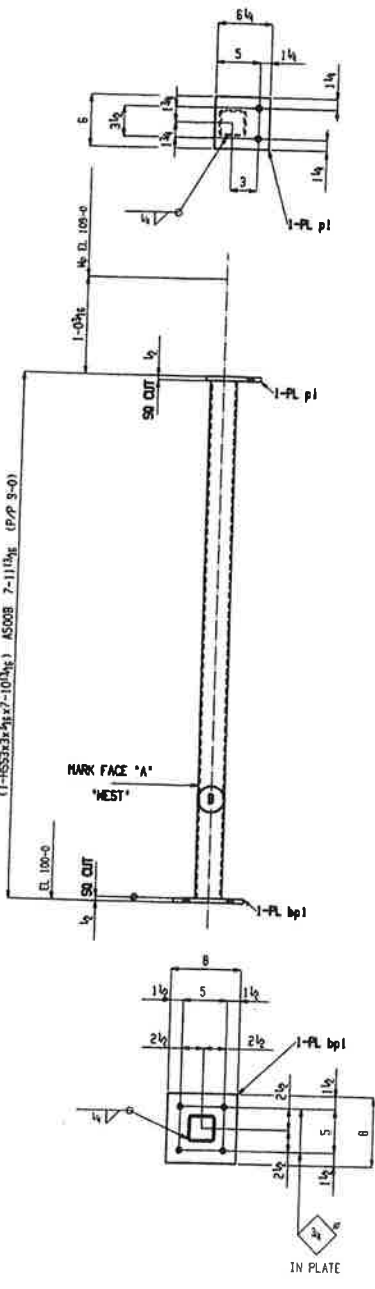

ONE COLUMN ICI

SEQ	PC	FORM	QTY	DESCRIPTION	LENGTH	REMARKS	MATERIAL
1	ICI	ICI	1	HSS3x3x1/2-10	7.100kg	MSK 7-110kg	MS
				PL 10	0.100	MSK 7-110kg	MS
				PL 10	0.100	MSK 7-110kg	MS
				PL 10	0.100	MSK 7-110kg	MS
				PL 10	0.100	MSK 7-110kg	MS

BILL OF MATERIAL

SHOP NOTES:  
 1.0 MAX. TOL. INT'L. ASH. ASS. 0.50 U.S. OTHER INT'L. ASH. ASS. U.S. PIPE INT'L. ASTM A53, GRADE B U.S.  
 2.0 HOLE DIA. TYP. U.S. FIELD HOLES ARE 1/8" OVER-4 TYP. U.S.A.  
 3.0 HOLE DIA. AT CONNECTION ANGLES ARE 1/8" OVER-4 TYP. U.S. FIELD HOLES MUST BE TOLERANCE CONTROL TYPE  
 4.0 ALL DIMENSIONS ARE IN MILLIMETERS UNLESS OTHERWISE NOTED  
 5.0 ALL DIMENSIONS ARE TO FACE UNLESS OTHERWISE NOTED  
 6.0 ALL DIMENSIONS ARE TO FACE UNLESS OTHERWISE NOTED  
 7.0 ALL DIMENSIONS ARE TO FACE UNLESS OTHERWISE NOTED  
 8.0 ALL DIMENSIONS ARE TO FACE UNLESS OTHERWISE NOTED  
 9.0 ALL DIMENSIONS ARE TO FACE UNLESS OTHERWISE NOTED  
 10.0 ALL DIMENSIONS ARE TO FACE UNLESS OTHERWISE NOTED

FINISH NOTE: ONE COAT OXIDE PRIMER

ALL VERIFICATION REQUESTS ON THIS SET OF DRAWINGS WILL BE ASSUMED CORRECT AS SHOWN UNLESS OTHERWISE NOTED. THE CONTRACTOR IS RESPONSIBLE TO CORROBORATE WITH THE ARCHITECT AND ENGINEER AS NECESSARY TO COMPLETE VERIFICATION REQUESTS, OF WHICH DELAY MAY BE INCURRED. ANY VERIFICATION COST ARE TO BE BORNE BY THE CONTRACTOR UNLESS OTHERWISE NOTED.  
 NO BACK CHANGES ACCEPTED WITHOUT WRITTEN APPROVAL FROM WOLF STEEL CONSTRUCTION INC.  
 DOCUMENTATION MUST INCLUDE PC-MARK, NETWORK REQUIRED AND COST OF REWORK.  
 REVISIONS OR MODIFICATIONS FROM THIS DRAWING IS NOT PERMITTED WITHOUT WRITTEN PERMISSION FROM WOLF STEEL CONSTRUCTION INC.

PROJECT: PETE SAUD HOUSE  
 LOCATION: FORD RD  
 DRAWING NO: 110-PS  
 DATE: 11/10/08  
 FILE NUMBER: 110-PS-001

Wolf Steel Construction, Inc  
 100 East Ave. # 110  
 P.O. Box 101250  
 Phoenix, AZ 85068

Total weight: 63

(1-HSS32x3/4x7-10<sup>1/2</sup>) AS500B 7-11<sup>3/4</sup> (P/P 9-0)

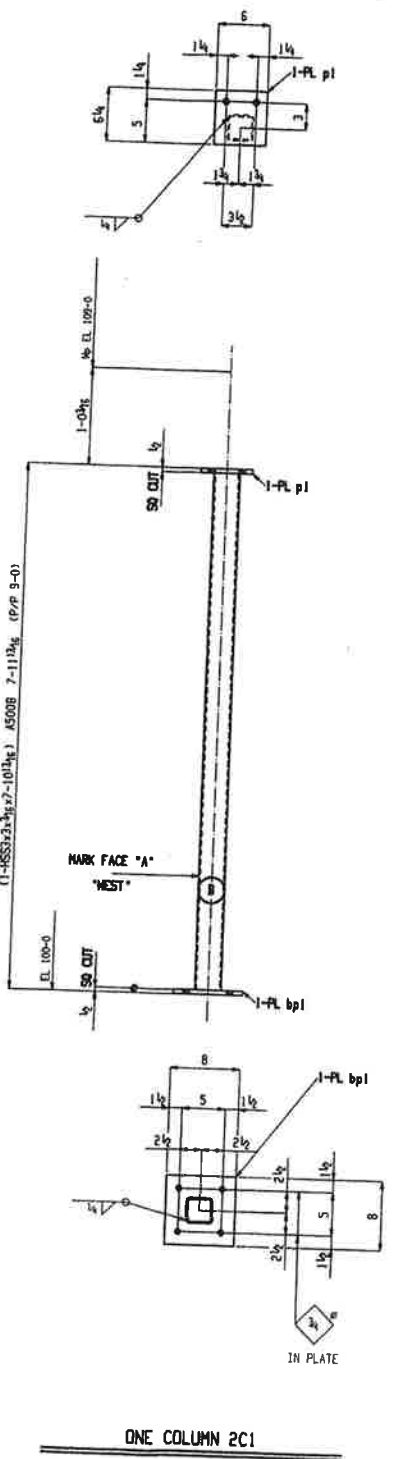

**BILL OF MATERIAL**

SEQ	PK	QUANTITY	DESCRIPTION	REMARKS	UNIT
1	2C1	1	1 HSS32x3/4x7-10 <sup>1/2</sup>	SIZE AS500B	LB
2	1-PL	1	1 PL 1/4x4	0.8 AS5	LB
3	1-PL	1	1 PL 1/4x4	0.8 AS5	LB
4	1-PL	1	1 PL 1/4x4	0.8 AS5	LB
5	1-PL	1	1 PL 1/4x4	0.8 AS5	LB

FINISH NOTE: ONE COAT OXIDE PRIMER

- SHOP NOTES:**
1. ALL WELDS SHALL BE MADE TO U.S. WELDER INST. ASTM A5.01, PIPE W/1.0, ASTM A5.03, GRADE B U.S.
  2. ALL WELDS SHALL BE MADE TO U.S. WELDER INST. ASTM A5.01, PIPE W/1.0, ASTM A5.03, GRADE B U.S.
  3. ALL WELDS SHALL BE MADE TO U.S. WELDER INST. ASTM A5.01, PIPE W/1.0, ASTM A5.03, GRADE B U.S.
  4. ALL WELDS SHALL BE MADE TO U.S. WELDER INST. ASTM A5.01, PIPE W/1.0, ASTM A5.03, GRADE B U.S.
  5. ALL WELDS SHALL BE MADE TO U.S. WELDER INST. ASTM A5.01, PIPE W/1.0, ASTM A5.03, GRADE B U.S.
  6. ALL WELDS SHALL BE MADE TO U.S. WELDER INST. ASTM A5.01, PIPE W/1.0, ASTM A5.03, GRADE B U.S.

**WOLF STEEL CONSTRUCTION INC.**

PROJECT: PETE SAND HOUSE  
 LOCATION: FAND, MO  
 CONTRACTOR: FULL SERVICE, INC.

DATE: 11/15/2011  
 REV: 001  
 DESCRIPTION: RESIDENCE

DATE: 11/15/2011  
 REV: 001  
 DESCRIPTION: RESIDENCE

2C1

(11-HSS3x3x1/4x2'-10 1/2") AS608 7-11 1/2" (P/P 3-0)

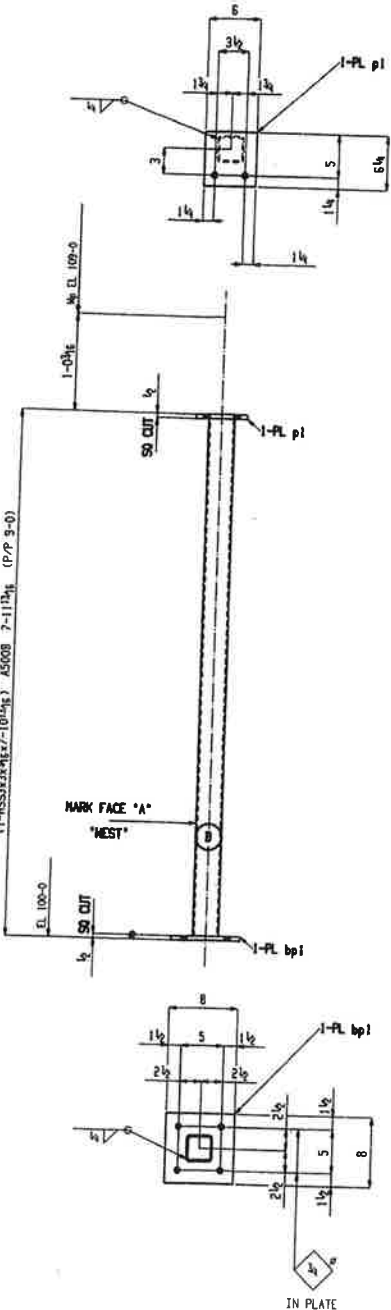

ONE COLUMN 3C1

- SHOP NOTES:
1. 1/2 WIDE FLG. INT'L. ASTM A572 GR. 50 U.S. OTHER INT'L. ASTM A572 U.S. PIPE INT'L. ASTM A53, GRADE B U.S.
  2. 15 INT'L. ASTM A572 GR. 50 U.S.
  3. 1/2 WIDE FLG. INT'L. ASTM A572 GR. 50 U.S. OTHER INT'L. ASTM A572 U.S. PIPE INT'L. ASTM A53, GRADE B U.S.
  4. 1/2 WIDE FLG. INT'L. ASTM A572 GR. 50 U.S. OTHER INT'L. ASTM A572 U.S. PIPE INT'L. ASTM A53, GRADE B U.S.
  5. 1/2 WIDE FLG. INT'L. ASTM A572 GR. 50 U.S. OTHER INT'L. ASTM A572 U.S. PIPE INT'L. ASTM A53, GRADE B U.S.
  6. 1/2 WIDE FLG. INT'L. ASTM A572 GR. 50 U.S. OTHER INT'L. ASTM A572 U.S. PIPE INT'L. ASTM A53, GRADE B U.S.

ALL VERIFICATION REQUESTS ON THIS SET OF DRAWINGS WILL BE ASSUMED CORRECT AS SHOWN UNLESS OTHERWISE NOTED. THESE FABRICATOR HAS REQUESTED INFORMATION TO BE PROVIDED. CONTRACTOR IS RESPONSIBLE TO CONSULT WITH DESIGNER, ARCHITECT, AND ENGINEER AS NECESSARY. IN COMPLETE VERIFICATION REQUESTS, OR STEEL DELIVERY NOT BE DELAYED. ANY INFORMATION COST BE TO INCOMPLETE OR INACCURATE VERIFICATION REQUESTS WILL BE HELD AS EXTRA TO THE CONTRACT... NO BACK CHANGES ACCEPTED WITHOUT WRITTEN APPROVAL FROM WOLF STEEL CONSTRUCTION INC. DOCUMENTATION MUST INCLUDE PC MARKS, NETWORK REQUIRED AND COST OF NETWORK. REPRODUCTION OF FABRICATION FROM THIS DRAWING IS NOT PERMITTED WITHOUT WRITTEN PERMISSION FROM WOLF STEEL CONSTRUCTION INC.

FINISH NOTE: ONE COAT OXIDE PRIMER

PROJECT: PETE SAND HOUSE		FORM: WOLF STEEL
LOCATION: FARM JOB		REV: 01
CONTRACTOR: WOLF STEEL CONSTRUCTION INC.		DATE: 11/11/11
FILE NUMBER: 1118-PS		SCALE: 3/16"
DATE: 11/11/11		BY: [Signature]
CHECKED BY: [Signature]		DATE: 11/11/11
APPROVED BY: [Signature]		DATE: 11/11/11

Total weight: 63

BILL OF MATERIAL				REVISIONS	
NO.	QTY	DESCRIPTION	AMOUNT	DATE	BY
1	1	11-HSS3x3x1/4x2'-10 1/2"	10.5		
2	2	1-PL pi	2.0		
3	1	1-PL bp1	1.0		
4	1	IN PLATE	0.5		

3C1

(1-M12x25x5-4) ASSD 5-4 (P/P 5-4)

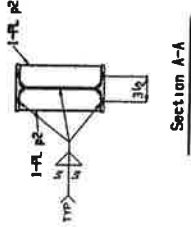
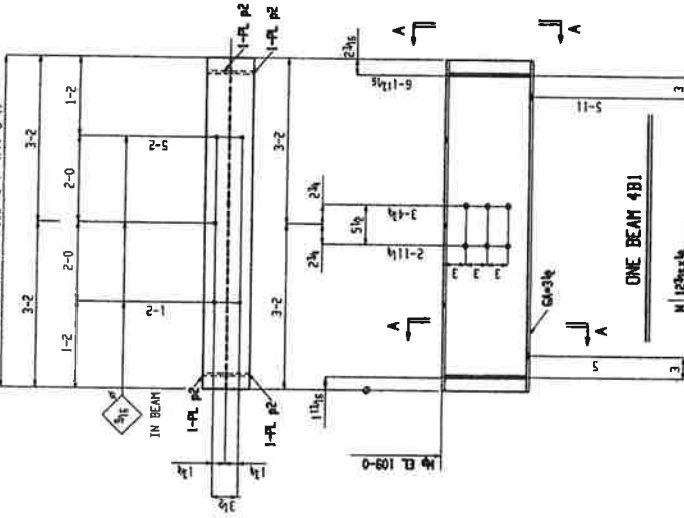

- SHOP NOTES:**
- 1.2 WIRE MESH ASTM A616 OR 50 U.S. OTHER WPT.L ASTM ARE U.S. PIPE WPT.L ASTM A53, GRADE B U.S.
  - 1.3 WIRE MESH ASTM A616 OR 50 U.S. OTHER WPT.L ASTM ARE U.S. PIPE WPT.L ASTM A53, GRADE B U.S.
  - 2.1 GUSSET END TYPE U.S. TYPE 1 U.S.A.
  - 2.2 GUSSET END TYPE U.S. TYPE 2 U.S.A.
  - 2.3 GUSSET END TYPE U.S. TYPE 3 U.S.A.
  - 3.1 SHOP WELDS AT CONNECTION ANGLES ARE 3/16" PROTECTIVE ANCHOR BOLTS MUST BE OFF TOP AND BOTTOM TYPE
  - 4.1 USE 1" HIGH SPACER WIGGS OVER ALL SLIPS IN CONNECTION ANGLES IN FIELD CONNECTIONS
  - 5.1 ALL WELDS SHALL BE TO BE 100% ELECTRODES / FULL PENETRATION WELDED (CONFORM-ONE PROCESS)
  - 5.2 ALL WELDS TO BE TO BE 100% ELECTRODES / FULL PENETRATION WELDED (CONFORM-ONE PROCESS)
  - 5.3 ALL WELDS TO BE TO BE 100% ELECTRODES / FULL PENETRATION WELDED (CONFORM-ONE PROCESS)
  - 5.4 ALL WELDS TO BE TO BE 100% ELECTRODES / FULL PENETRATION WELDED (CONFORM-ONE PROCESS)

NO BACK CHARGES ACCEPTED WITHOUT WRITTEN APPROVAL FROM WOLF STEEL CONSTRUCTION INC.  
 DOCUMENTATION MUST INCLUDE P.C.M.N.R. NETWORK INQUIRED AND COST OF REWORK  
 REPAIRATION OR FABRICATION FROM THIS DRAWING IS NOT PERMITTED WITHOUT  
 WRITTEN PERMISSION FROM WOLF STEEL CONSTRUCTION INC.

FINISH NOTE: ONE COAT OXIDE PRIMER

	PROJECT: PETE SAND HOUSE
CONTRACTOR:	LOCATION: FARM, MO
WOLF STEEL CONSTRUCTION, INC.	FILE NUMBER: 108
<b>Wolf Steel Construction, Inc</b>	DATE: 7/1/2015
1082 East Ave. N	4B1
Faribault, MN 56009	
Phone: 763.258.0989	

**BILL OF MATERIAL**

QTY	PK	DESCR	QTY	DESCRIPTION	LOCATION	REMARKS	WEIGHT TOTAL
1	4B1	1	1	100258	5'-4"	100%	173
2	4B2	4	115%	100258	0-115%	100%	173
3	4B3	4	115%	100258	0-115%	100%	173
4	4B4	4	115%	100258	0-115%	100%	173
5	4B5	4	115%	100258	0-115%	100%	173
Total weight : 775							

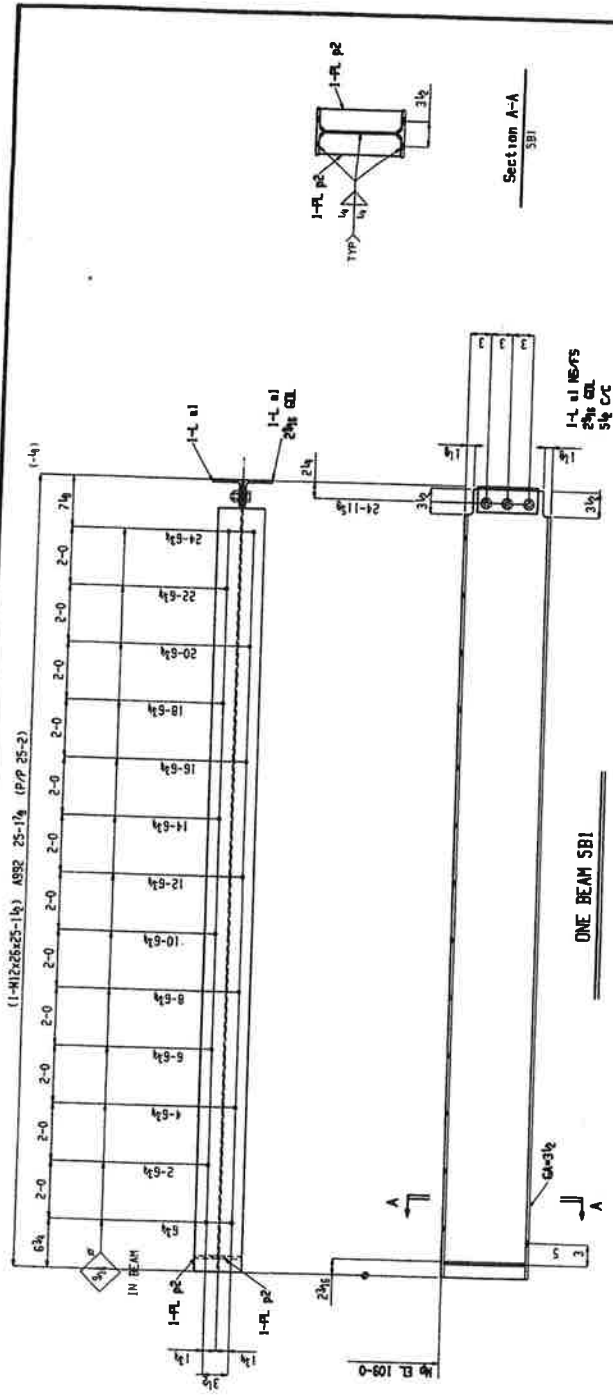

Section A-A  
SBI

ONE BEAM SBI  
W 12 1/2 x 14  
F 6 1/2 x 3/4  
K 1 1/2 x 2 1/4

SHIP BOLTS:  
3 - 3/4 x 2 1/4 A325

SEQ	PK	QTY	UNIT	DESCRIPTION	LENGTH	WEIGHT	REMARKS
1	1	1	ONE BEAM	11 HP-FS 2 1/2" C/L 5 1/2" D/C	14'-0"	424	
2	1	2	PL	1/4" x 3 1/2"	0'-0"	11	
3	1	2	PL	1/4" x 3 1/2"	0'-0"	11	
4	1	3	BOLTS	3/4" Dia A325	0'-0"	2	
5	1	2	PL	1/4" x 3 1/2"	0'-0"	11	
6	1	5	BOLTS	3/4" Dia A325	0'-0"	2	

FINISH NOTE: ONE COAT OXIDE PRIMER

SHOP NOTES:  
 1. ALL WELDS SHALL BE MADE WITH E7018 OR E7024 ELECTRODES, OTHER METALS AS SHOWN.  
 2. ALL WELDS SHALL BE MADE WITH E7018 OR E7024 ELECTRODES, OTHER METALS AS SHOWN.  
 3. ALL WELDS SHALL BE MADE WITH E7018 OR E7024 ELECTRODES, OTHER METALS AS SHOWN.  
 4. ALL WELDS SHALL BE MADE WITH E7018 OR E7024 ELECTRODES, OTHER METALS AS SHOWN.  
 5. ALL WELDS SHALL BE MADE WITH E7018 OR E7024 ELECTRODES, OTHER METALS AS SHOWN.  
 6. ALL WELDS SHALL BE MADE WITH E7018 OR E7024 ELECTRODES, OTHER METALS AS SHOWN.

**WOLF STEEL CONSTRUCTION, INC.**  
 PROJECT: PETE SAHO HOUSE  
 LOCATION: PANDI, AB  
 ENGINEER: PETE SAHO  
 CONTRACTOR: FILE NUMBER: INC

NO BACK CHANGES ACCEPTED WITHOUT WRITTEN APPROVAL FROM WOLF STEEL CONSTRUCTION INC.  
 DOCUMENTATION MUST INCLUDE F.C. RECORD, NETWORK REQUIRED AND COST OF REWORK.  
 REVISIONS OF FABRICATION FROM THIS DRAWING IS NOT PERMITTED WITHOUT WRITTEN PERMISSION FROM WOLF STEEL CONSTRUCTION INC.

DATE: 10/15/2011  
 TIME: 10:00 AM  
 DRAWN BY: SBI  
 CHECKED BY: SBI  
 DATE: 10/15/2011  
 PROJECT: PETE SAHO HOUSE  
 LOCATION: PANDI, AB  
 ENGINEER: PETE SAHO  
 CONTRACTOR: FILE NUMBER: INC

Total weight: 674

**FINDINGS OF FACT AND ORDER**  
**of the**  
**BOARD OF CITY COMMISSIONERS**  
**OF THE CITY OF FARGO**

Property Address: 427 15<sup>th</sup> Avenue South, Fargo, North Dakota

Owner: James Peter Sabo

A hearing was held before the Board of City Commissioners of the City of Fargo on the 13<sup>th</sup> day of August, 2018 regarding property located at 427 15<sup>th</sup> Avenue South, Fargo, North Dakota. Bruce Taralson, Building Official, appeared on behalf of the city of Fargo Inspections Department and provided testimony as to the condition of the property. James Peter Sabo, the owner of the property, appeared and provided testimony. In addition, owners of property nearby the subject property appeared and offered testimony, including, J. Michael Johnson, Leroy Anderson, and Teresa Roberts.

The matter came on for further proceedings before the Board of City Commissioners at the Board's regular meeting of September 10, 2018 at which meeting the Board allowed additional testimony, including that of Mr. Sabo, to be presented.

The Board heard the testimony offered by the inspections department, owner, and neighboring property owners, and considered the reports, evidence and other information presented, and hereby makes the following Findings of Fact:

**FINDINGS OF FACT**

1. That James Peter Sabo is the owner of the following described real property located in the City of Fargo, County of Cass and State of North Dakota:

Lot 113 in Belmont Park Addition to the city of Fargo

The street address for which is: 427 15<sup>th</sup> Avenue South, Fargo, North Dakota, 58103.

2. That the subject property is vacant.

3. That on June 12, 2018, Joseph Girdner, Residential Housing Inspector to the city of Fargo, inspected the property and found the building, consisting of a multistory, wood-framed

**EXHIBIT L**

structure to be a dangerous building within the standards set forth in Article 21-04 of the Fargo Municipal Code and Section 108 of the International Property Maintenance Code concerning dangerous structures. Additionally, Joseph Girdner observed and reported that numerous code violations exist and the deterioration of the property is extensive.

4. That on June 22, 2018, Robert E. Harshberger, Deputy Assessor of the city of Fargo, performed an inspection on the property and determined that the estimated cost to repair the property would exceed fifty percent (50%) of the building value as established by the Fargo Assessment Department.

5. That the building is unsafe and is a dangerous building in the following respects: the building is structurally unsound, there are many and various code violations, multiple permits have been issued for work that has never been completed, that work has been completed without necessary permits and that there is substandard workmanship.

6. Further, the City Commission finds that the following conditions exist with respect to the subject property:

- a. The structure has been damaged or deteriorated for more than fifty percent (50%) of its original value;
- b. The building is unsafe, fails to provide the amenities essential to decent living, and is unfit for human habitation; and
- c. The building it is unsafe or dangerous to the health, moral safety or general welfare of the people of the City of Fargo.

7. That the information in the files of the Inspection Department, and the City Assessor's Office stemming from various inspections of the property on or before June 22, 2018, with respect to the subject property is hereby accepted as true and correct.

8. That the building located at 427 15<sup>th</sup> Avenue South, Fargo, North Dakota 58103, is hereby found to be a "dangerous building."

9. Notice of Dangerous Building was posted on the property on or about June 25, 2018, in accordance with Municipal Code § 21-0404. The Notice of Dangerous Building informed the owner and all occupants, if any, that the "dangerous building" must be vacated and

the building demolished within 30 days from the date of the notice.

10. The owner was properly served by certified mail with the Notice of Dangerous Building, dated Monday, June 25, 2018.

11. The owner has not sufficiently presented cause why the "dangerous building" should not be demolished.

12. Despite being ordered that the building on the subject property should be demolished or necessary permits be obtained within 30 days of the notice, the owner has failed to do so.

13. A hearing was held on August 13, 2018 at which time the owner appeared and presented testimony.

14. Subsequent to said August 13th hearing said owner, through his attorney, alleged that proper notice of the hearing had not be served upon the owner, to-wit: Fargo Municipal Code Section 21-0405(A) requires that the Board of City Commissioners give written notice to the owner to appear before it to show cause why the building or structure reported to be a "dangerous building" should not be repaired, vacated, or demolished, said written notice to be delivered by certified mail (according to Fargo Municipal Code §21-0408) and said notice to be posted in a conspicuous place at the location of the alleged dangerous building.

15. City officials have acknowledged that in fact, the required delivery by certified mail, of the notice of hearing did not occur nor was said notice posted on the alleged dangerous building, however, the owner acknowledged knowing about the August 13th hearing as early as July 27, 2018 and the owner actually appeared at the August 13th hearing. Therefore, the owner had actual notice of the hearing and was not prejudiced by the failure to receive written notice by certified mail or the posting of the notice on the property.

16. Based upon the foregoing, the Board of City Commissioners hereby finds that the property owner, James Peter Sabo, had actual notice of the August 13th hearing, he appeared at the hearing and, therefore, he suffered no prejudice as a result of the lack of formal written notice.



**ORDER**

Based on the foregoing Findings of Fact, it is hereby ORDERED that James Peter Sabo or anyone else claiming an ownership interest shall demolish the "dangerous building" located at 427 15<sup>th</sup> Avenue South, Fargo, North Dakota.

It is further ordered that James Pete Sabo or anyone else claiming an ownership interest in the building shall have 30 days from the date of service of this Order within which to demolish the "dangerous building" located at 427 15<sup>th</sup> Avenue South, Fargo, North Dakota.

It is further ordered that if the owner fails to demolish said "dangerous building," the City Auditor, Building Inspector and City Attorney are directed to act on behalf of the city of Fargo to cause the "dangerous building" to be demolished, and the cost of said demolition to be assessed against the subject property as provided in Section 21-0405 of the Fargo Municipal Code.

DATED this 10 day of September, 2018.

BOARD of CITY COMMISSIONERS of the CITY  
OF FARGO,  
a North Dakota Municipal Corporation

By   
Timothy J. Mahoney, M.D., Mayor

ATTEST:

  
Steven Sprague, City Auditor

**NOTICE TO PROPERTY OWNER**

TO: JAMES PETER SABO

YOU ARE HEREBY GIVEN NOTICE that you shall have 30 days from the date of service of Findings of Fact and Order of the Board of City Commissioners of the City of Fargo ("Order") upon you in which to appeal the Order to the District Court of Cass County, North Dakota, or to take such other legal action to enjoin the enforcement of this Order as you deem proper, all in accordance with the appeal procedure set forth in Fargo Municipal Code § 21-0412. You are further given notice that the "dangerous building" on the subject property may be demolished by the city of Fargo at any time on or after 30 days from the date of service hereof.

DATED this 10 day of September, 2018.

BOARD OF CITY COMMISSIONERS  
CITY OF FARGO, a North Dakota Municipal Corporation

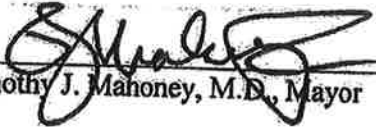
By   
Timothy J. Mahoney, M.D., Mayor

ATTEST:  
  
Steven Sprague, City Auditor

AFFIDAVIT OF SERVICE BY CERTIFIED MAIL

STATE OF NORTH DAKOTA    )  
  ) ss.  
COUNTY OF CASS            )

Re: Findings of Fact and Order

Linda Workin, being first duly sworn and being of legal age, deposes and says that on the 14th day of September, 2018, she served the attached Findings of Fact and Order upon James Peter Sabo, by placing true and correct copies thereof in an envelope addressed as follows:

James Peter Sabo  
1221 9<sup>th</sup> Avenue North  
Fargo, ND 58102

and deposited the same, with postage prepaid, in the United States mail at Fargo, North Dakota, Certified Mail.

  
Linda Workin

Subscribed and sworn to before me this 14 day of Sept, 2018.

  
Erik R. Johnson, Notary Public  
Cass County, North Dakota  
My Commission Expires: September 24, 2022

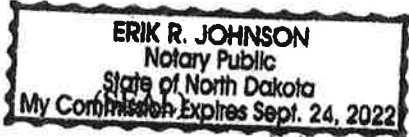

**SENDER: COMPLETE THIS SECTION**

- Complete items 1, 2, and 3.
- Print your name and address on the reverse so that we can return the card to you.
- Attach this card to the back of the mailpiece, or on the front if space permits.

1. Article Addressed to:

James Peter Sabo  
1221 9th Ave. N.  
Fargo, ND 58102



9590 9402 1913 6104 0681 82

2. Article Number (transfer from service label)

7015 3430 0000 3082 0844

PS Form 3811, July 2015 PSN 7530-02-000-9053

**COMPLETE THIS SECTION ON DELIVERY**

A. Signature  Agent  
 X *James Sabo*  Addressee

B. Received by (Printed Name)  Date of Delivery  
*James Sabo* *9-15*

D. Is delivery address different from item 1?  Yes  No  
 If YES, enter delivery address below:

3. Service Type

<input type="checkbox"/> Adult Signature Restricted Delivery	<input type="checkbox"/> Priority Mail Express®
<input type="checkbox"/> Certified Mail®	<input type="checkbox"/> Registered Mail™
<input type="checkbox"/> Collect on Delivery	<input type="checkbox"/> Registered Mail Restricted Delivery
<input type="checkbox"/> Collect on Delivery Restricted Delivery	<input type="checkbox"/> Return Receipt for Merchandise
<input type="checkbox"/> Insured Mail (Over \$500)	<input type="checkbox"/> Signature Confirmation™
	<input type="checkbox"/> Signature Confirmation Restricted Delivery

Domestic Return Receipt

4490 290E 0000 0EHE 5T02

**U.S. Postal Service™**  
**CERTIFIED MAIL® RECEIPT**  
*Domestic Mail Only*

For delivery information, visit our website at [www.usps.com](http://www.usps.com)

FARGO, ND 58102

**OFFICIAL USE**

Certified Mail Fee	\$ 3.45	\$3.45
Extra Services & Fees (check box, add fee as appropriate)		\$7.75
<input checked="" type="checkbox"/> Return Receipt (hardcopy)	\$ 3.00	
<input type="checkbox"/> Return Receipt (electronic)	\$ 0.00	
<input type="checkbox"/> Certified Mail Restricted Delivery	\$ 0.00	
<input type="checkbox"/> Adult Signature Required	\$ 0.00	
<input type="checkbox"/> Adult Signature Restricted Delivery	\$ 0.00	
Postage	\$ 0.50	\$0.71
<b>Total Postage and Fees</b>	<b>6.91</b>	<b>6.91</b>

Sent to  
**James Peter Sabo**  
 Street and Apt. No., or PO Box No.  
**1321 9th Ave. N.**  
 City, State, ZIP+4®  
**Fargo, ND 58102**

PS Form 3800, April 2015 PSN 7530-02-000-9047 See Reverse for Instructions



USPS TRACKING #



9590 9402 1933 6104 0651 52



First-Class Mail  
Postage & Fees Paid  
USPS  
Permit No. G-10

United States  
Postal Service

• Sender: Please print your name, address, and ZIP+4® in this box\*

**Erik R. Johnson & Associates, Ltd.**  
505 Broadway St. N., Suite 206  
Fargo, ND 58102

**AFFIDAVIT OF SERVICE**

STATE OF NORTH DAKOTA    )  
  ) ss.  
COUNTY OF CASS            )

**Re: Posting of Notice of Findings of Fact and Order**

Joseph Girdner, being first duly sworn and being of legal age, deposes and says that on the 14 day of September, 2018, he posted the attached Notice of Finding of Fact Order upon the following address:

427 15 AVE S.  
Fargo, ND 58103

  
Joseph Girdner

Subscribed and sworn to before me this 14 day of Sept., 2018.

JILL PAGEL  
Notary Public  
State of North Dakota  
My Commission Expires Feb. 26, 2021

(SEAL)

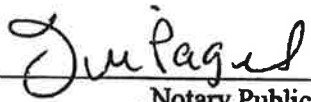
  
\_\_\_\_\_, Notary Public  
Cass County, North Dakota  
My Commission Expires: Feb 26, 2021



September 7, 2018

Pete Sabo  
1221 9<sup>th</sup> Ave N  
Fargo, ND 58102

RE: 427 15<sup>th</sup> Ave S, Fargo ND

This letter is subsequent to the report composed on 7/5/2018 outlining structural deficiencies at the residential remodel in progress located at 427 15<sup>th</sup> Ave S, in Fargo. The building will be of safe occupation upon the following conditions:

1. The deficiencies noted pertaining to the main floor wall framing, second floor support beam and respective footings, second floor joists, second floor piping (not commenting on plumbing however general location of piping to avoid penetrations of the second-floor framing), stair bearing walls, and foundation bracing described in the 7/5/2018 report are completed.
2. The deficiencies noted in the 7/5/2018 report are inspected by the city officials in the process as to which the inspections normally occur.
3. Any additional work beyond what was in progress and available to view at the time of the report are completed in accordance with the normal standard of care of the industry and inspected.

If you have any questions, please feel free to call at any time.

Thank you,

A handwritten signature in black ink, appearing to read 'KURT SANDMAN', is written over a faint, larger version of the same signature.

Kurt Sandman, PE  
Owner/Principal

**EXHIBIT M**





7

Office of the City Attorney

City Attorney  
Erik R. Johnson

Assistant City Attorney  
Nancy J. Morris

October 4, 2018

Board of City Commissioners  
City Hall  
225 4<sup>th</sup> Street North  
Fargo, ND 58102

**RE: Roberts Commons Condo Amendment and Easement**

Dear Commissioners:

I have enclosed two documents for your review and approval relating to the Roberts Commons parking garage wrap project and condominium. The first is an amendment to the condominium declaration that established the "partnership" between the City and the owner of the building that wraps around the parking garage. This amendment simply allows the installation of ventilation to the rooftop of the parking garage for the benefit of the restaurant being established on the ground floor of the wrap building. The second document is the lease of a small area (the equivalent of a small parking space) for a pet area for the benefit of the apartment occupants of the wrap and the Dillard building project being constructed to the north of the parking garage. Jim Gilmour will be present at your meeting to respond to any questions regarding these two requests.

**SUGGESTED MOTION:** I move to approve the First Amendment to the Roberts Commons Condominium Declaration and the Lease for the pet area, both as presented.

Sincerely,

Erik R. Johnson

ERJ/lmw

Enclosures



**PET AREA ACCESS EASEMENT AGREEMENT**

**THIS PET AREA ACCESS EASEMENT AGREEMENT** (the “Agreement”) is made as of the \_\_\_ day of \_\_\_\_\_, 2018 (the “Effective Date”), by and between DFI Roberts LLC, a North Dakota limited liability company (“Roberts”), and City of Fargo, North Dakota, a municipal corporation of the State of North Dakota (“City”)

**RECITALS**

A. Roberts is the sole Owner of Unit 1, Roberts Commons Condominium, a condominium created under a Declaration Establishing a Plan of Condominium Ownership recorded in the office of the Recorder for Cass County, North Dakota as Doc. No. 1523132 (the “Wrap Unit”).

B. City is the sole Owner of Unit 2, Roberts Commons Condominium, a condominium created under a Declaration Establishing a Plan of Condominium Ownership recorded in the office of the Recorder for Cass County, North Dakota as Doc. No. 1523132 (the “Garage Unit”). The Wrap Unit and the Garage Unit are sometimes referred to individually as a “Unit” or collectively as the “Units”.

C. Roberts desires to receive from City, and City is willing to grant to Roberts, an easement on, over and across a portion of the Garage Unit to be used by the Wrap Unit to create and maintain a secured area and access point to a pet excrement area located on a roof of the Wrap Unit, all on terms and conditions set forth below.

**AGREEMENTS**

**IN CONSIDERATION** of the Recitals and the following covenants, the Declarant declares as follows:

- 1. **Easement Grant.** City hereby grants, conveys, creates and establishes, for the benefit of the Wrap Unit, an exclusive, perpetual and appurtenant easement over, upon and across that part of the 5<sup>th</sup> level of the Garage Unit depicted on attached Exhibit A (the

“Easement Area”) for the installation, use, repair, maintenance and replacement of fencing, gates, doors, secured entry devices and other materials and equipment as may be reasonably necessary to serve as a means of access to a pet excrement area located on a roof of the Wrap Unit.

2. **Consideration.**

A. **Monthly Payment.** Until and unless the owner of the Wrap Unit expressly releases the rights created in this Agreement by recording a release instrument against the Wrap Unit and the Garage Unit in the office of the Recorder for Cass County, North Dakota, the owner of the Wrap Unit shall pay to the owner of the Garage Unit, in advance and without notice, the sum of \$100, in Constant Dollars, per month.

B. **Constant Dollars.** For the purposes of this Agreement, “Constant Dollars” shall mean the present value of the U.S. dollar amount to which such phrase refers. An adjustment shall occur on January 1 of the 6th calendar year following the Effective Date, and thereafter at 5-year intervals. Constant Dollars shall be determined by multiplying the dollar amount to be adjusted by a fraction, the numerator of which is the Current Index Number and the denominator of which is the Base Index Number. The “Base Index Number” shall be the CPI for the month of the Effective Date; the “Current Index Number” shall be the CPI for the month of September of the year preceding the adjustment year; the “Index” shall be the CPI. “CPI” means the United States Department of Labor, Bureau of Labor Statistics, All Items Consumer Price Index for All Urban Consumers (CPI-U) for All items in Midwest – Size Class B/C (2,500,000 persons or less) (1996 = 100). If the manner in which such Consumer Price Index is determined shall be changed, or if 1996 shall no longer be used as the base year, such adjustment shall be made in calculations using such successor or revised index as may be specified by the issuing agency for the purpose of compensating for the change. If such Consumer Price Index shall become unavailable to the public because publication is discontinued, or otherwise, the Garage Unit owner shall substitute therefor an index reasonably determined by Garage Unit owner.

C. **Remedies for Non-Payment.** In the event that the owner of the Wrap Unit fails to make any payments required of it under this Agreement or otherwise perform any of its obligations under this Agreement, then the owner of the Garage Unit may suspend the use of the easement rights created under this Agreement until such time as all payments due (plus interest, costs, and expenses, as applicable) have been paid in full; provided, however, the owner of the Garage Unit shall not suspend the use of such rights until after giving written notice of the delinquent amount and/or other non-performance and the owner of the Wrap Unit’s failure to cure same within 15 days after delivery of such notice. If the owner of the Garage Unit has suspended the rights of the Wrap Unit in accordance with the foregoing for a period exceeding 180 days, the owner of the Garage Unit may, after providing the owner of the Wrap Unit an additional

written notice setting out all delinquent amounts and/or other items of non-performance and the owner of the Wrap Unit's failure to cure all items within 15 days following such written notice, terminate this Agreement, by recording a termination instrument against the Wrap Unit and the Garage Unit in the office of the Recorder for Cass County, North Dakota.

3. **Use and Maintenance.** The Wrap Unit owner shall, as its sole cost and expense, undertake all repair, maintenance and replacement of the modifications it makes to, and the items it places in, the Easement Area. If and when this Agreement terminates, for whatever reason, the Wrap Unit owner shall, at its cost and expense, remove all items it has placed in the Easement Area and shall restore the Easement Area to substantially the same condition as existed as of the Effective Date, ordinary wear and tear excepted.

4. **Taxes/Special Assessments.** The owner of each Unit shall be solely responsible for the payment of real estate taxes, special assessments and insurance pertaining to its Unit.

5. **Insurance/Waiver of Claims and Subrogation.**

A. The owner of the Wrap Unit shall keep in full force and effect, at its expense, a policy or policies of insurance with companies licensed to do business in the state in which the Units are located with the following coverages: (1) public liability and property damage insurance and automobile liability insurance with respect to the Wrap Unit and the business of the Wrap Unit owner, with a minimum coverage of \$1,000,000 per occurrence and not less than \$2,000,000 annual aggregate for this location; (2) if the nature of an owner's operation is such as to place any or all of its employees under the coverage of Workers' Compensation or similar statutes, such owner shall also keep in force, at its expense, Workers' Compensation or similar insurance affording statutory coverage and containing statutory limits; (3) Employers Liability Insurance with coverage of not less than \$1,000,000; (4) umbrella coverage in the amount of not less than \$10,000,000 providing excess coverage over the levels required for coverages in phrases (1) and (3) above; and (5) insurance for fire and extended coverage, insuring for the full replacement cost, all items the Wrap Unit owner places in the Easement Area. Such policies, where applicable and to the maximum extent possible, shall name the owner of the Garage Unit as an additional insured. Upon Garage Unit owner's written request, the Wrap Unit owner shall furnish certificates evidencing that any such insurance required is in effect and, if available, stating that Garage Unit owner shall be notified in writing 10 days prior to cancellation, material change or nonrenewal of insurance. All dollar amounts set forth above are in Constant Dollars.

B. The Wrap Unit owner hereby waives any rights it may have against the Garage Unit owner arising out of or in any way related to the Easement Area to the extent that any damage or loss is coverable by insurance required of it under

this Agreement, and on behalf of its insurance companies to the maximum extent permitted by law, the Wrap Unit owner waives any right of subrogation it may have against the Garage Unit owner.

6. **Indemnification.** The Wrap Unit owner shall indemnify and hold the Garage Unit owner harmless from and against any damages, injuries, claims, suits, liabilities, costs, expenses or the like, including, without limitation, reasonable attorney's fees and costs (whether or not any legal proceedings are commenced) arising out of or in any way related to Roberts' use of the Easement Area and the use by the Wrap Unit owner's employees, tenants, guests, invitees, contractors or the like.

7. **Inconsistent Grants.** The Garage Unit owner shall not hereafter grant to any other party any rights or interests in, nor do anything that would materially interfere with the Wrap Unit owner's use of, the Easement Area. Notwithstanding the foregoing, the Garage Unit owner may access the Easement Area from time to time as is reasonably necessary to repair, maintain or replace elements of the Garage Unit, and any such activities shall not be deemed an inconsistent grant or material interference so long as undertaken in a commercially reasonable manner and in a manner causing the least interference with the Wrap Unit owner's use of the Easement Area as is practicable under the circumstances and any property of the Wrap Unit owner is promptly restored by the Garage Unit owner to its prior condition.

8. **Notices.** All communications, demands, notices, or objections permitted or required to be given or served under this Agreement shall be in writing and shall be deemed to have been duly given or served if delivered in person to a required recipient or its duly authorized agent, or deposited in the United States Mail, postage prepaid, for mailing by certified mail, return receipt requested, or deposited with a nationally-recognized carrier, postage prepaid, and in any event addressed to the owner of a Unit at the same address set forth in the records of Cass County, North Dakota for the receipt of real estate tax statements pertaining to such owner. A party entitled to notice hereunder may change its address for notices from time to time by providing written notice to the other owner.

9. **Late Payment Fee/Interest/Lien.** If any amount due under this Agreement is paid more than 10 days late, in addition to any other rights and remedies, non-paying owner shall pay a late payment fee equal to five percent of the delinquent payment. All past-due sums, including any unpaid late payment fees, shall accrue interest at the rate of the lesser of: (1) 10% per annum; or (2) the maximum rate permitted by law.

10. **Attorneys' Fees.** In the event of a dispute under this Agreement, the prevailing party shall be entitled to receive its reasonable attorneys' fees and costs from the non-prevailing party or parties.

11. **Governing Law.** This Agreement shall be construed and enforced in accordance with the laws of the State of North Dakota. Any action brought to enforce the terms of

this Agreement shall be brought in a court of competent jurisdiction and venued in Cass County, North Dakota.

12. **Successors and Assigns/Meanings.** The rights and obligations hereunder shall run with the Units and shall inure to and bind the owners of the Units and their successors and assigns. When used herein, the term “perpetual” shall mean indefinitely or the longest period allowed by law, now or at any time in the future. When used herein, the singular shall include the plural, the plural shall include the singular. The Wrap Unit owner shall may grant a license to other persons to use the Easement Area for purposes consistent with the rights granted by City under this Agreement, but such persons shall have no greater rights than are granted to Roberts hereunder, the Wrap Unit owner shall be responsible for the acts and omissions of such other persons and the rights of such other persons shall suspend or terminate, as the case may be, if and when the rights of the Wrap Unit owner are suspended or terminated.

**IN WITNESS WHEREOF**, the undersigned have executed this Agreement as of date first written above.

*[The remainder of this page intentionally left blank – signature page follows]*

**DFI ROBERTS LLC**

By: \_\_\_\_\_  
Bill Rothman, Vice President

STATE OF NORTH DAKOTA )  
  )SS  
COUNTY OF CASS                     )

The foregoing instrument was acknowledged before me this \_\_\_\_\_ day of \_\_\_\_\_, 2018, by Bill Rothman, the Vice President of DFI Roberts LLC, a North Dakota limited liability company, on behalf of the limited liability company.

\_\_\_\_\_  
Notary Public  
My Commission Expires: \_\_\_\_\_

**CITY OF FARGO,  
a North Dakota municipal  
corporation**

By:

\_\_\_\_\_  
Timothy J. Mahoney

Its: Mayor

ATTEST:

\_\_\_\_\_  
Steven Sprague, City Auditor

STATE OF NORTH DAKOTA )

) ss.

COUNTY OF CASS )

On this \_\_\_\_ day of \_\_\_\_\_, 2017, before me, a notary public in and for said county and state, personally appeared TIMOTHY J. MAHONEY and STEVEN SPRAGUE, to me known to be the Mayor and City Auditor, respectively, of the CITY OF FARGO, a North Dakota municipal corporation, described in and that executed the within and foregoing instrument, and acknowledged that said municipal corporation executed the same.

(SEAL)

\_\_\_\_\_  
Notary Public  
Cass County, ND

This instrument was drafted by:  
Bueide Law Firm (DAB)  
1 Second Street North, Suite 100  
Fargo, ND 58102



**EXHIBIT A**  
**[Drawing of Easement Area]**

**FIRST AMENDMENT TO  
ROBERTS COMMONS CONDOMINIUM  
DECLARATION ESTABLISHING A PLAN OF  
CONDOMINIUM OWNERSHIP**

**THIS FIRST AMENDMENT** (the “Amendment”) dated as of the \_\_\_\_ day of \_\_\_\_\_, 2018, is by and between the undersigned parties.

**RECITALS**

A. DFI Roberts LLC, a North Dakota limited liability company (“Roberts”), whose address is 210 Broadway N., Suite 300, Fargo, ND 58102, is the sole Owner of Unit 1, Roberts Commons Condominium, a condominium created under a Declaration Establishing a Plan of Condominium Ownership recorded in the office of the Recorder for Cass County, North Dakota as Doc. No. 1523132.

B. City of Fargo, North Dakota, a municipal corporation of the State of North Dakota (“City”), whose address is ATTN: City Auditor, City Hall, 200 N. 3<sup>rd</sup> Street, Fargo, ND 58102 is the sole Owner of Unit 2, Roberts Commons Condominium, a condominium created under a Declaration Establishing a Plan of Condominium Ownership recorded in the office of the Recorder for Cass County, North Dakota as Doc. No. 1523132.

C. Roberts and City are, collectively, referred to as the “Declarants”, the Declaration referenced above is referred to as the “Declaration”, and Unit 1 and Unit 2 are the only two Units created by the Declaration.

D. Declarants wish to amend the Declaration to reflect the creation and expansion of certain additional Limited Common Areas.

E. To the extent used but not specifically defined in this Amendment, defined terms shall have the meaning ascribed to them in the Declaration, the Covenants and/or the Bylaws.

**AGREEMENTS**

In consideration of the Recitals and the following mutual agreements, the parties amend the Declaration as follows:

1. **Exhibit A Drawings.** Exhibit A to the Declaration is deleted in its entirety and replaced by Exhibit A attached to this Amendment.
  
2. **Limited Common Area.** Section 8 of the Declaration is deleted in its entirety and restated as follows:

8. Limited Common Area. "Limited Common Areas" are Common Areas designated or designed for the primary use by one but not both of the Owners. Unless delegated by the Association to an Owner, all maintenance, repair or replacement to the Limited Common Areas shall be the responsibility of the Association, but the costs thereof shall be allocated to the Unit specifically entitled to use, or as a practical matter the only Unit that does use, same. Among the Limited Common Areas are: (a) the following items, referred to as the "Specific Limited Common Areas": (i) existing and possibly future mail box clusters located in the atrium portion of the Common Area and labeled as "LCA – 2.2' x 3.7' MAILBOXES" and "LCA – 1.8' x 16.5' MAILBOXES" on attached Exhibit A; (ii) doors and related access and security equipment allowing for pedestrian passage between the Wrap Unit and the Garage Unit and labeled "LCA – 3.3' DOORWAY" on attached Exhibit A; and (iii) areas for the installation, repair, replacement and maintenance of self-contained grease storage equipment, exhaust ducts/vents, refrigerator and air compressors and related lines and wiring, security fencing and any other equipment reasonably necessary to support restaurant operations in the Wrap, such areas of varying dimensions and labeled "LCA – WRAP AUXILIARY AREAS" on attached Exhibit A (collectively, the "Specific Limited Common Areas"); and (b) any equipment and distributary installations for services such as electricity, light, telephone, communications, gas, hot and cold water, heat and refrigeration, storm sewer and sanitary sewer (including all panels, meters, pipes, ducts, wires, cables, conduits and the like used in connection therewith) located within a Unit and serving only the other Unit or located in a Common Area and serving only one Unit.

3. Binding Effect/Further Amendment. Except as expressly amended hereby, the Declaration and all exhibits thereto remain unmodified and in full force and effect.

IN WITNESS WHEREOF, Declarants have executed this Amendment as of the date first above written.

*[the remainder of this page intentionally left blank – signature pages follow]*



**CITY OF FARGO,  
a North Dakota municipal corporation**

By: \_\_\_\_\_  
Timothy J. Mahoney

Its: Mayor

ATTEST:

\_\_\_\_\_  
Steven Sprague, City Auditor

STATE OF NORTH DAKOTA )

) ss.

COUNTY OF CASS )

On this \_\_\_\_ day of \_\_\_\_\_, 2017, before me, a notary public in and for said county and state, personally appeared TIMOTHY J. MAHONEY and STEVEN SPRAGUE, to me known to be the Mayor and City Auditor, respectively, of the CITY OF FARGO, a North Dakota municipal corporation, described in and that executed the within and foregoing instrument, and acknowledged that said municipal corporation executed the same.

(SEAL)

\_\_\_\_\_  
Notary Public  
Cass County, ND

**EXHIBIT A**

[Revised drawings for all levels to add the new LCA areas]

CITY OF  
**Fargo**  
ASSESSMENT DEPARTMENT



September 20, 2018

Board of City Commissioners  
City Hall  
Fargo, ND 58102

Dear Commissioners:

Chapter 57-02.2 of the North Dakota Century Code provides for a property tax exemption for certain types of improvements made to existing buildings.

I have attached a copy of an application for real estate tax exemption of building improvements for the property at 215 8 St. S as submitted by Ellen & Rodney Shafer. A description of the property involved, types of improvements to be made, and assessment information are indicated on the application.

It is my opinion that the value of some of the improvements, referred to in the application, qualifies for the exemption. This exemption would be for the years 2018, 2019, 2020, 2021, & 2022.

The estimated annual tax revenue lost by granting the exemption, based upon the estimated cost of the improvements, would be about \$215 with the City of Fargo's share being \$35.

Sincerely,

Ben Hushka  
City Assessor

hah  
attachment

**Application For Property Tax Exemption For Improvements  
To Commercial And Residential Buildings**  
North Dakota Century Code ch. 57-02.2  
(File with the local city or township assessor)

**Property Identification**

1. Name of Property Owner Ellen & Rodney Shafer Phone No. 701/298-2998 **ELL**

2. Address of Property 215 8 Sts

City FARGO State ND Zip Code 58103

3. Legal description of the property for which the exemption is being claimed. L+C B1K 24 Original Townsite

4. Parcel Number 01-2240-0280000 Residential  Commercial  Central Business District

5. Mailing Address of Property Owner Same

City \_\_\_\_\_ State \_\_\_\_\_ Zip Code \_\_\_\_\_

**Description Of Improvements For Exemption**

6. Describe the type of renovating, remodeling or alteration made to the building for which the exemption is being claimed (attach additional sheets if necessary). Construct 16' x 17' addition for mudroom + bathroom

7. Building Permit No. 170380 8. Year Built 1906

9. Date of Commencement of making the improvement April 2017

10. Estimated market value of property before improvement \$ 367,300

11. Cost of making the improvement (all labor, material and overhead) \$ 15,000 \$40,000

12. Estimated market value of property after improvement \$ \_\_\_\_\_

**Applicant's Certification and Signature**

13. I certify that the above information is correct to the best of my knowledge and I apply for this exemption.

Applicant's Signature [Signature] Date 1-12-18

**Assessor's Determination**

14. The local assessor finds that the improvements in this application has  has not  met the qualifications for exemption for the following reason(s): 5 YEARS FOR QUALIFYING WORK

Assessor's Signature [Signature] Date 9/21/18

**Action of Governing Body**

15. Action taken on this application by local governing board of the county or city: Denied  Approved

Approval subject to the following conditions: \_\_\_\_\_

Chairman of Governing Body \_\_\_\_\_ Date \_\_\_\_\_



CITY OF  
**Fargo**  
ASSESSMENT DEPARTMENT

86

September 20, 2018

Board of City Commissioners  
City Hall  
Fargo, ND 58102

Dear Commissioners:

Chapter 57-02.2 of the North Dakota Century Code provides for a property tax exemption for certain types of improvements made to existing buildings.

I have attached a copy of an application for real estate tax exemption of building improvements for the property at 301 20 Ave. N as submitted by Mary Steussy. A description of the property involved, types of improvements to be made, and assessment information are indicated on the application.

It is my opinion that the value of some of the improvements, referred to in the application, qualifies for the exemption. This exemption would be for the years 2017, 2018, 2019, 2020, & 2021.

The estimated annual tax revenue lost by granting the exemption, based upon the estimated cost of the improvements, would be about \$135 with the City of Fargo's share being \$25.

Sincerely,



Ben Hushka  
City Assessor

hah  
attachment

**Application For Property Tax Exemption For Improvements  
To Commercial And Residential Buildings**  
North Dakota Century Code ch. 57-02.2  
(File with the local city or township assessor)

**Property Identification**

1. Name of Property Owner Mary Steussy Phone No. 701/566-1571

2. Address of Property 301 20 Ave N

City FARGO State ND Zip Code 58102

3. Legal description of the property for which the exemption is being claimed. Lt 18, Blk 2, Halland Newman 1st

4. Parcel Number 01-1100-00520-000 Residential  Commercial  Central Business District

5. Mailing Address of Property Owner Same

City \_\_\_\_\_ State \_\_\_\_\_ Zip Code \_\_\_\_\_

**Description Of Improvements For Exemption**

6. Describe the type of renovating, remodeling or alteration made to the building for which the exemption is being claimed (attach additional sheets if necessary). Remodel Bathroom

7. Building Permit No. 152270 8. Year Built 1953

9. Date of Commencement of making the improvement 01/01/16

10. Estimated market value of property before improvement \$ 157,700

11. Cost of making the improvement (all labor, material and overhead) \$ 13,000

12. Estimated market value of property after improvement 168,300

**Applicant's Certification and Signature**

13. I certify that the above information is correct to the best of my knowledge and I apply for this exemption.

Applicant's Signature Mary Steussy Date 9/13/2018

**Assessor's Determination**

14. The local assessor finds that the improvements in this application has  has not  met the qualifications for exemption for the following reason(s): 5 YEARS FOR QUALIFYING WORK

Assessor's Signature [Signature] Date 9/21/18

**Action of Governing Body**

15. Action taken on this application by local governing board of the county or city: Denied  Approved

Approval subject to the following conditions: \_\_\_\_\_

Chairman of Governing Body \_\_\_\_\_ Date \_\_\_\_\_

CITY OF  
**Fargo**  
ASSESSMENT DEPARTMENT

80

September 20, 2018

Board of City Commissioners  
City Hall  
Fargo, ND 58102

Dear Commissioners:

Chapter 57-02.2 of the North Dakota Century Code provides for a property tax exemption for certain types of improvements made to existing buildings.

I have attached a copy of an application for real estate tax exemption of building improvements for the property at 172 North Woodcrest Dr. N as submitted by Paul J. & Ann L. Jarvis. A description of the property involved, types of improvements to be made, and assessment information are indicated on the application.

It is my opinion that the value of some of the improvements, referred to in the application, qualifies for the exemption. This exemption would be for the years 2019, 2020, 2021, 2022, & 2023.

The estimated annual tax revenue lost by granting the exemption, based upon the estimated cost of the improvements, would be about \$700 with the City of Fargo's share being \$120.

Sincerely,



Ben Hushka  
City Assessor

hah  
attachment

**Application For Property Tax Exemption For Improvements  
To Commercial And Residential Buildings**  
North Dakota Century Code ch. 57-02.2  
(File with the local city or township assessor)

**Property Identification**

1. Name of Property Owner Paul & Ann Jarvis Phone No. 701-306-8276

2. Address of Property 172 North Woodcrest Dr N  
City FARGO State ND Zip Code 58102

3. Legal description of the property for which the exemption is being claimed Lt 23 Blk 16 Woodcrest 3rd

4. Parcel Number 01-4060-00700-000 Residential  Commercial  Central Business District

5. Mailing Address of Property Owner Same  
City \_\_\_\_\_ State \_\_\_\_\_ Zip Code \_\_\_\_\_

**Description Of Improvements For Exemption**

6. Describe the type of renovating, remodeling or alteration made to the building for which the exemption is being claimed (attach additional sheets if necessary). Kitchen remodel

7. Building Permit No. 180159 8. Year Built 1972

9. Date of Commencement of making the improvement Feb. 2018

10. Estimated market value of property before improvement \$ 349,000

11. Cost of making the improvement (all labor, material and overhead) \$ 54,428.00

12. Estimated market value of property after improvement \$ \_\_\_\_\_

**Applicant's Certification and Signature**

13. I certify that the above information is correct to the best of my knowledge and I apply for this exemption.

Applicant's Signature *Paul J. Jarvis* Date 9/5/18

**Assessor's Determination**

14. The local assessor finds that the improvements in this application has  has not  met the qualifications for exemption for the following reason(s) 5 YEARS FOR QUALIFYING WORK

Assessor's Signature *[Signature]* Date 9/24/18

**Action of Governing Body**

15. Action taken on this application by local governing board of the county or city: Denied  Approved

Approval subject to the following conditions: \_\_\_\_\_

Chairman of Governing Body \_\_\_\_\_ Date \_\_\_\_\_



ASSESSMENT DEPARTMENT

September 20, 2018

Board of City Commissioners  
City Hall  
Fargo, ND 58102

Dear Commissioners:

Chapter 57-02.2 of the North Dakota Century Code provides for a property tax exemption for certain types of improvements made to existing buildings.

I have attached a copy of an application for real estate tax exemption of building improvements for the property at 1226 Oak St. N as submitted by Ryan & Krista French. A description of the property involved, types of improvements to be made, and assessment information are indicated on the application.

It is my opinion that the value of some of the improvements, referred to in the application, qualifies for the exemption. This exemption would be for the years 2019, 2020, 2021, 2022, & 2023.

The estimated annual tax revenue lost by granting the exemption, based upon the estimated cost of the improvements, would be about \$1025 with the City of Fargo's share being \$175.

Sincerely,

A handwritten signature in cursive script, appearing to read "Ben Hushka".

Ben Hushka  
City Assessor

hah  
attachment

**Application For Property Tax Exemption For Improvements  
To Commercial And Residential Buildings**  
North Dakota Century Code ch. 57-02.2  
(File with the local city or township assessor)

**Property Identification**

1. Name of Property Owner Ryan & Krista French Phone No. 612-419-0145

2. Address of Property 1226 Oak St. N  
 City FARGO State ND Zip Code 58102

3. Legal description of the property for which the exemption is being claimed. Lot 7 & S 1/2 of 8 Blk 1  
Bernard Holes 2nd

4. Parcel Number 01-1320-00080-000 Residential  Commercial  Central Business District

5. Mailing Address of Property Owner Same  
 City \_\_\_\_\_ State \_\_\_\_\_ Zip Code \_\_\_\_\_

**Description Of Improvements For Exemption**

6. Describe the type of renovating, remodeling or alteration made to the building for which the exemption is being claimed (attach additional sheets if necessary). Repl. flooring, sheetrock, doors, trim, bathroom fixtures. Remodel existing bath, incl. flooring, fixtures, vent, pl, and elec. Basement family room, bedroom, 2 new egress windows

7. Building Permit No. 180010 8. Year Built 1967

9. Date of Commencement of making the improvement 2018

10. Estimated market value of property before improvement \$ 265,000

11. Cost of making the improvement (all labor, material and overhead) \$ 80,000

12. Estimated market value of property after improvement \$ 350,000

**Applicant's Certification and Signature**

13. I certify that the above information is correct to the best of my knowledge and I apply for this exemption.  
 Applicant's Signature [Signature] Date 9/12/18

**Assessor's Determination**

14. The local assessor finds that the improvements in this application has  has not  met the qualifications for exemption for the following reason(s): 5 YEARS FOR QUALIFYING WORK  
 Assessor's Signature [Signature] Date 9/21/18

**Action of Governing Body**

15. Action taken on this application by local governing board of the county or city: Denied  Approved   
 Approval subject to the following conditions: \_\_\_\_\_  
 \_\_\_\_\_  
 Chairman of Governing Body \_\_\_\_\_ Date \_\_\_\_\_

CITY OF  
**Fargo**  
ASSESSMENT DEPARTMENT



September 20, 2018

Board of City Commissioners  
City Hall  
Fargo, ND 58102

Dear Commissioners:

Chapter 57-02.2 of the North Dakota Century Code provides for a property tax exemption for certain types of improvements made to existing buildings.

I have attached a copy of an application for real estate tax exemption of building improvements for the property at 1329 2 St. N as submitted by Craig A. & Nichole L. Brandenburger. A description of the property involved, types of improvements to be made, and assessment information are indicated on the application.

It is my opinion that the value of some of the improvements, referred to in the application, qualifies for the exemption. This exemption would be for the years 2018, 2019, 2020, 2021, & 2022.

The estimated annual tax revenue lost by granting the exemption, based upon the estimated cost of the improvements, would be about \$25 with the City of Fargo's share being \$5.

Sincerely,



Ben Hushka  
City Assessor

hah  
attachment

**Application For Property Tax Exemption For Improvements  
To Commercial And Residential Buildings**

North Dakota Century Code ch. 57-02.2  
(File with the local city or township assessor)

**Property Identification**

1. Name of Property Owner Craig & Nichole Brandenburger Phone No. (605) 670-9879

2. Address of Property 1329 2nd St N  
 City FARGO State ND Zip Code 58102

3. Legal description of the property for which the exemption is being claimed. lot 8 block 7 of Holes 1st

4. Parcel Number 01-1360-01920-000 Residential  Commercial  Central Business District

5. Mailing Address of Property Owner 1329 2nd St N.  
 City Fargo State ND Zip Code 58102

**Description Of Improvements For Exemption**

6. Describe the type of renovating, remodeling or alteration made to the building for which the exemption is being claimed (attach additional sheets if necessary). new windows, fence, front deck

7. Building Permit No. 171326 8. Year Built 1941

9. Date of Commencement of making the improvement July 2017 - Nov 2017

10. Estimated market value of property before improvement \$ 197,700

11. Cost of making the improvement (all labor, material and overhead) \$ 23,000

12. Estimated market value of property after improvement \$ 199,700

**Applicant's Certification and Signature**

13. I certify that the above information is correct to the best of my knowledge and I apply for this exemption.

Applicant's Signature Nichole Brandenburger Date 6.29.18

**Assessor's Determination**

14. The local assessor finds that the improvements in this application has  has not  met the qualifications for exemption for the following reason(s): 5 YEARS FOR QUALIFYING WORK

Assessor's Signature Don Christensen Date 9/21/18

**Action of Governing Body**

15. Action taken on this application by local governing board of the county or city: Denied  Approved

Approval subject to the following conditions: \_\_\_\_\_

Chairman of Governing Body \_\_\_\_\_ Date \_\_\_\_\_



CITY OF  
**Fargo**  
ASSESSMENT DEPARTMENT



September 20, 2018

Board of City Commissioners  
City Hall  
Fargo, ND 58102

Dear Commissioners:

Chapter 57-02.2 of the North Dakota Century Code provides for a property tax exemption for certain types of improvements made to existing buildings.

I have attached a copy of an application for real estate tax exemption of building improvements for the property at 3226 Bohnet Blvd. N as submitted by Nathan R. & Susan A. Brenneman. A description of the property involved, types of improvements to be made, and assessment information are indicated on the application.

It is my opinion that the value of some of the improvements, referred to in the application, qualifies for the exemption. This exemption would be for the years 2019, 2020, 2021, 2022 & 2023.

The estimated annual tax revenue lost by granting the exemption, based upon the estimated cost of the improvements, would be about \$785 with the City of Fargo's share being \$135.

Sincerely,



Ben Hushka  
City Assessor

hah  
attachment

Attn: Teresa

**Application For Property Tax Exemption For Improvements  
To Commercial And Residential Buildings**

North Dakota Century Code ch. 57-02.2  
(File with the local city or township assessor)

**Property Identification**

1. Name of Property Owner Nathan R. & Susan A. Brenneman Phone No. 701-232-1597

2. Address of Property 3226 Bonnet Blvd. N

City FARGO State ND Zip Code 58102

3. Legal description of the property for which the exemption is being claimed. Lot 10 BIKI  
GOLF Course 5th

4. Parcel Number 01-1605-00100-000 Residential  Commercial  Central Business District

5. Mailing Address of Property Owner SAME

City \_\_\_\_\_ State \_\_\_\_\_ Zip Code \_\_\_\_\_

**Description Of Improvements For Exemption**

6. Describe the type of renovating, remodeling or alteration made to the building for which the exemption is being claimed (attach additional sheets if necessary). Reside Dwelling  
Siding, windows, Garage Door

7. Building Permit No. 180773 8. Year Built 1978

9. Date of Commencement of making the improvement 05/30/18

10. Estimated market value of property before improvement \$ 265,200

11. Cost of making the improvement (all labor, material and overhead) \$ 61,140

12. Estimated market value of property after improvement \$ \_\_\_\_\_

**Applicant's Certification and Signature**

13. I certify that the above information is correct to the best of my knowledge and I apply for this exemption.

Applicant's Signature NAB Date 8-31-18

**Assessor's Determination**

14. The local assessor finds that the improvements in this application has  has not  met the qualifications for exemption for the following reason(s): 5 YEARS FOR QUALIFYING WORK

Assessor's Signature Don Munka Date 9/21/18

**Action of Governing Body**

15. Action taken on this application by local governing board of the county or city: Denied  Approved

Approval subject to the following conditions: \_\_\_\_\_

Chairman of Governing Body \_\_\_\_\_ Date \_\_\_\_\_



September 20, 2018

Board of City Commissioners  
City Hall  
Fargo, ND 58102

Dear Commissioners:

Chapter 57-02.2 of the North Dakota Century Code provides for a property tax exemption for certain types of improvements made to existing buildings.

I have attached a copy of an application for real estate tax exemption of building improvements for the property at 1032 3 St. N as submitted by Stephen J. & Nowelle Kissler. A description of the property involved, types of improvements to be made, and assessment information are indicated on the application.

It is my opinion that the value of some of the improvements, referred to in the application, qualifies for the exemption. This exemption would be for the years 2019, 2020, 2021, 2022, & 2023.

The estimated annual tax revenue lost by granting the exemption, based upon the estimated cost of the improvements, would be about \$450 with the City of Fargo's share being \$75.

Sincerely,

A handwritten signature in cursive script, appearing to read "Ben Hushka".

Ben Hushka  
City Assessor

hah  
attachment

**Application For Property Tax Exemption For Improvements  
To Commercial And Residential Buildings**  
North Dakota Century Code ch. 57-02.2  
(File with the local city or township assessor)

**Property Identification**

1. Name of Property Owner Stephen & Nowelle Kisser Phone No. 701-261-6508

2. Address of Property 1032 3 St N

City FARGO State ND Zip Code 58102

3. Legal description of the property for which the exemption is being claimed. Lot 20 Blk 12 Hectors

4. Parcel Number 01-1160-02270-000 Residential  Commercial  Central Business District

5. Mailing Address of Property Owner same

City \_\_\_\_\_ State \_\_\_\_\_ Zip Code \_\_\_\_\_

**Description Of Improvements For Exemption**

6. Describe the type of renovating, remodeling or alteration made to the building for which the exemption is being claimed (attach additional sheets if necessary). Remodel Kitchen

7. Building Permit No. 180236 8. Year Built 1917

9. Date of Commencement of making the improvement March 2018

10. Estimated market value of property before improvement \$ 195,300

11. Cost of making the improvement (all labor, material and overhead) \$ 35,000

12. Estimated market value of property after improvement \$ \_\_\_\_\_

**Applicant's Certification and Signature**

13. I certify that the above information is correct to the best of my knowledge and I apply for this exemption.

Applicant's Signature Nowelle Kissen Date 9/10/18

**Assessor's Determination**

14. The local assessor finds that the improvements in this application has  has not  met the qualifications for exemption for the following reason(s): 5 YEARS FOR QUALIFYING WORK

Assessor's Signature Den Dunbar Date 9/21/18

**Action of Governing Body**

15. Action taken on this application by local governing board of the county or city: Denied  Approved

Approval subject to the following conditions: \_\_\_\_\_

Chairman of Governing Body \_\_\_\_\_ Date \_\_\_\_\_

25.00 CC

9/24/18

(9a)



# APPLICATION FOR A LOCAL PERMIT OR CHARITY LOCAL PERMIT

OFFICE OF ATTORNEY GENERAL  
SFN 9338 (08/2016)

Application for:  Local Permit  Charity Local Permit (one event per year)

Name of Non-profit Organization <b>Lewis and Clark Elementary PTA</b>	Date(s) of Activity <b>Oct. 26, 2018</b>	For a raffle, provide drawing date(s): <b>Oct. 26, 2018</b>	
Person Responsible for the Gaming Operation and Disbursement of Net Income <b>Benjamin Willey</b>	Title <b>Committee Chairperson</b>	Business Phone Number <b>701-799-3665</b>	
Business Address <b>1729 16 St S</b>	City <b>Fargo</b>	State <b>ND</b>	Zip Code <b>58103</b>
Mailing Address (if different) <b>same</b>	City	State	Zip Code
Name of Site Where Game(s) will be Conducted <b>Lewis and Clark Elementary</b>	Site Address <b>1729 16 St S</b>		
City <b>Fargo</b>	State <b>ND</b>	Zip Code <b>58103</b>	County <b>Cass</b>

Check the Game(s) to be Conducted: \* Poker, Twenty-one, and Paddlewheels may be Conducted only by a Charity Local Permit.

Bingo  Raffle  Raffle Board  Calendar Raffle  Sports Pool  Poker \*  Twenty-one \*  Paddlewheels \*

## DESCRIPTION AND RETAIL VALUE OF PRIZES TO BE AWARDED

Game Type	Description of Prize	Retail Value of Prize	Game Type	Description of Prize	Retail Value of Prize
Raffle	Art/Crafts Baskets	\$ 200 <sup>00</sup>			
Raffle	Baking Baskets	\$ 200 <sup>00</sup>			
Raffle	Books/Reading Baskets	\$ 200 <sup>00</sup>			
Raffle	Board Game Baskets	\$ 200 <sup>00</sup>			
Raffle	Coffee Baskets	\$ 200 <sup>00</sup>			
Raffle	Sports Themed Baskets	\$ 200 <sup>00</sup>			
Raffle	Beauty/Luxury Baskets	\$ 200 <sup>00</sup>			
				Total:	(Limit \$12,000 per year) \$ 1,400 <sup>00</sup>

Intended uses of gaming proceeds: PTA General Fund to support in school and extracurricular activities.

Does the organization presently have a state gaming license?  No  Yes - If "Yes," the organization is not eligible for a local permit or charity local permit and should call the Office of Attorney General at 1-800-326-9240. **BW**

Has the organization received a charity local permit from this or another city or county for the fiscal year July 1 through June 30?  No  Yes - If "Yes," the organization does not qualify for a local permit or charity local permit.

Has the organization received a local permit from this or another city or county for the fiscal year July 1 through June 30?  No  Yes - If "Yes," indicate the total value of all prizes previously awarded: \$ \_\_\_\_ This amount is part of the total prize limit of \$12,000 per year.

Signature of Organization's Top Executive Official <b>Rachel ...</b>	Date <b>9/21/18</b>	Title <b>Vice President</b>	Business Phone Number <b>320-760-5309</b>
---	------------------------	--------------------------------	--



**APPLICATION FOR A LOCAL PERMIT OR CHARITY LOCAL PERMIT**  
 OFFICE OF ATTORNEY GENERAL  
 SFN 9338 (08/2016)

96

Application for:  Local Permit \*  Charity Local Permit (one event per year)

Name of Non-profit Organization <b>Jefferson Elementary PTA</b>		Date(s) of Activity <b>10/26/18 to 6-8pm</b>		For a raffle, provide drawing date(s): <b>10-26-18</b>	
Person Responsible for the Gaming Operation and Disbursement of Net Income <b>Ashley Mack</b>		Title <b>PTA President</b>		Business Phone Number <b>7017403002</b>	
Business Address <b>1701 4th Ave.S.</b>		City <b>Fargo</b>		State <b>ND</b>	Zip Code <b>58103</b>
Mailing Address (if different)		City		State	Zip Code
Name of Site Where Game(s) will be Conducted <b>Jefferson Elementary School</b>		Site Address <b>1701 4th Ave.S.</b>			
City <b>Fargo</b>		State <b>ND</b>	Zip Code <b>58103</b>	County <b>Cass</b>	
Check the Game(s) to be Conducted: * Poker, Twenty-one, and Paddlewheels may be Conducted only by a Charity Local Permit.					
<input type="checkbox"/> Bingo <input checked="" type="checkbox"/> Raffle <input type="checkbox"/> Raffle Board <input type="checkbox"/> Calendar Raffle <input type="checkbox"/> Sports Pool <input type="checkbox"/> Poker * <input type="checkbox"/> Twenty-one * <input type="checkbox"/> Paddlewheels *					

**DESCRIPTION AND RETAIL VALUE OF PRIZES TO BE AWARDED**

Game Type	Description of Prize	Retail Value of Prize	Game Type	Description of Prize	Retail Value of Prize
50/50 raffle	cash	depends on			
at costume		amount of			
dance		tickets sold.			
		*max # of			
		tickets sold			
		will be 500*			
		250. <sup>exc</sup>			

Profit will go to Jefferson PTA for student secret Santa gifts.

Total: \$ 250.00 (Limit \$12,000 per year)

Intended uses of gaming proceeds: 50/50 raffle at costume dance. Last year there was only approx. 300 tickets sold.

Does the organization presently have a state gaming license?  No  Yes - If "Yes," the organization is not eligible for a local permit or charity local permit and should call the Office of Attorney General at 1-800-326-9240.

Has the organization received a charity local permit from this or another city or county for the fiscal year July 1 through June 30?  No  Yes - If "Yes," the organization does not qualify for a local permit or charity local permit.

Has the organization received a local permit from this or another city or county for the fiscal year July 1 through June 30?  No  Yes - If "Yes," indicate the total value of all prizes previously awarded: \$ \_\_\_\_ . This amount is part of the total prize limit of \$12,000 per year.

Signature of Organization's Top Executive Official	Date	Title	Business Phone Number
--	------	-------	-----------------------

City of Fargo, Auditors Office - Gaming  
 200 N 3rd Street, Fargo, ND 58102  
 Phone: 701-241-1304  
 Rev. 07-2015

90

25.00  
 Value  
 10-1-18

Name of Student Organization <b>Kappa Psi Pharmaceutical Fraternity</b>		Date(s) of Activity <b>10/15/18</b>	
Person Responsible for the Gaming Operation <b>Rachel Johnson</b>		Time of Event <b>5-7</b> <input type="checkbox"/> a.m. <input checked="" type="checkbox"/> p.m.	
Street Address of Student Organization <b>1345 University Drive N.</b>		City <b>Fargo</b>	State <b>ND</b>
Name of Site Where Game(s) will be Conducted <b>Crossroads Lutheran Center</b>		Street Address <b>1201 13th Ave. N.</b>	
City <b>Fargo</b>	State <b>ND</b>	Zip Code <b>58102</b>	County <b>Cass</b>

Check the Game Types to be Conducted:  Bingo  Raffle Boards  Raffle  Calendar Raffle  Sports Pool

**DESCRIPTION AND RETAIL VALUE OF PRIZES TO BE AWARDED**

Game Type	Description of Prize	Retail Value of Prize	Game Type	Description of Prize	Retail Value of Prize
Raffle	Various gift cards	\$ <del>1000</del> 300			\$
		Prizes tablets			

(Limit \$12,000 per year)  
\$ 300

Intended uses of gaming proceeds: To raise money for a non-profit organization called Reach out and Read

Has the organization received a local permit from this or another city or county for the fiscal year July 1 through June 30?  No  Yes  
 If "Yes," indicate the total value of all prizes previously awarded: \$ \_\_\_\_\_. This amount is part of the total prize limit of \$12,000 per year.

**ACKNOWLEDGEMENT BY NDSU - Must be signed by the Associate Director of Student Activities and Student Organizations located in the Student Activities Office - Room 120 in Memorial Union.**

I acknowledge that the Kappa Psi Pharmaceutical Fraternity student organization is registered by the Administration of North Dakota State University.

Signature 	Title <b>Assoc. Director</b>	Date <b>10/1/18</b>	Business Phone Number <b>701-231-8242</b>
---------------	---------------------------------	------------------------	--

The policy of North Dakota State University requires that a student organization obtain a signed acknowledgment by its administration that the applicant is a registered student organization of NDSU.

Signature of Contact Person 	Title <b>Philanthropy Chair</b>	Date <b>10/1/18</b>	Business Phone Number <b>320-249-9856</b>
---------------------------------	------------------------------------	------------------------	--

9d

\$25.00  
10-1-18  
✓1946



**APPLICATION FOR A LOCAL PERMIT OR CHARITY LOCAL PERMIT**  
OFFICE OF ATTORNEY GENERAL  
SFN 9338 (08/2016)

Application for:  Local Permit    \*  Charity Local Permit (one event per year)

Name of Non-profit Organization <i>Home Builders Care of Fargo-Moorhead Foundation</i>		Date(s) of Activity <i>3/22/19 to 3/22/19</i>		For a raffle, provide drawing date(s): <i>3-22-19</i>	
Person Responsible for the Gaming Operation and Disbursement of Net Income <i>Summer Hammond</i>		Title <i>Development Coord.</i>		Business Phone Number <i>701-232-5846</i>	
Business Address <i>1802 32nd Ave S</i>		City <i>Fargo</i>		State <i>ND</i>	Zip Code <i>58103</i>
Mailing Address (if different)		City		State	Zip Code
Name of Site Where Game(s) will be Conducted <i>Holiday Inn</i>		Site Address <i>3803 13th Ave S</i>			
City <i>Fargo</i>		State <i>ND</i>	Zip Code <i>58103</i>	County <i>Cass</i>	
Check the Game(s) to be Conducted: * Poker, Twenty-one, and Paddlewheels may be Conducted only by a Charity Local Permit.					
<input type="checkbox"/> Bingo <input checked="" type="checkbox"/> Raffle <input type="checkbox"/> Raffle Board <input type="checkbox"/> Calendar Raffle <input type="checkbox"/> Sports Pool <input type="checkbox"/> Poker * <input type="checkbox"/> Twenty-one * <input type="checkbox"/> Paddlewheels *					

**DESCRIPTION AND RETAIL VALUE OF PRIZES TO BE AWARDED**

Game Type	Description of Prize	Retail Value of Prize	Game Type	Description of Prize	Retail Value of Prize
<i>Meat Raffle</i>	<i>Meat</i>	<i>200<sup>00</sup></i>			
<i>Cash Raffle</i>	<i>Cash 50/50</i>	<i>500<sup>00</sup></i>			
<i>Cash Raffle</i>	<i>Cash 50/50</i>	<i>400<sup>00</sup></i>			
<i>Wheelbarrow</i>	<i>Wheelbarrow</i>	<i>250<sup>00</sup></i>			
Total:					<i>\$ 1,350<sup>00</sup></i> <small>(Limit \$12,000 per year)</small>

Intended uses of gaming proceeds: *raise funds for Home Builders Care Foundation*

Does the organization presently have a state gaming license?  No     Yes - If "Yes," the organization is not eligible for a local permit or charity local permit and should call the Office of Attorney General at 1-800-326-9240.

Has the organization received a charity local permit from this or another city or county for the fiscal year July 1 through June 30?  No     Yes - If "Yes," the organization does not qualify for a local permit or charity local permit.

Has the organization received a local permit from this or another city or county for the fiscal year July 1 through June 30?  No     Yes - If "Yes," indicate the total value of all prizes previously awarded: \$ *300<sup>00</sup>* . This amount is part of the total prize limit of \$12,000 per year.

Signature of Organization's Top Executive Official <i>Summer Hammond</i>	Date <i>9/4/18</i>	Title <i>Foundation Administrator</i>	Business Phone Number <i>701-232-5846</i>
---	-----------------------	--	--





APPLICATION FOR A LOCAL PERMIT OR CHARITY LOCAL PERMIT
OFFICE OF ATTORNEY GENERAL
SFN 9338 (08/2016)

90

Cash 25.00
10/3/18

Application for: [X] Local Permit \* [ ] Charity Local Permit (one event per year)

Form with fields: Name of Non-profit Organization (Homeward Animal Shelter), Date(s) of Activity (10/19/2018 to 10/19/2018), Person Responsible (Samantha Mccarthy), Business Address (1201 28th Ave N), Mailing Address, Name of Site (The Holiday Inn), Site Address (3803 13th Ave S), City ( Fargo ), State ( ND ), Zip Code ( 58102-3301 ), County ( Cass ). Includes checkboxes for game types: Bingo, Raffle, Raffle Board, Calendar Raffle, Sports Pool, Poker, Twenty-one, Paddlewheels.

DESCRIPTION AND RETAIL VALUE OF PRIZES TO BE AWARDED

Table with 3 columns: Game Type, Description of Prize, Retail Value of Prize. Includes a Total row with a limit of \$12,000 per year.

Intended uses of gaming proceeds: All proceeds will go to the care of the homeless cats and dogs of Homeward Animals Shelter.
Does the organization presently have a state gaming license? [X] No [ ] Yes
Has the organization received a charity local permit from this or another city or county for the fiscal year July 1 through June 30? [X] No [ ] Yes
Has the organization received a local permit from this or another city or county for the fiscal year July 1 through June 30? [X] No [ ] Yes

Signature of Organization's Top Executive Official (Michael Senechal), Date (10/3/2018), Title (Executive Director), Business Phone Number ((701) 364-9013)



**APPLICATION FOR A LOCAL PERMIT OR CHARITY LOCAL PERMIT**  
 OFFICE OF ATTORNEY GENERAL  
 SFN 9338 (08/2016)

9/8

✓ 181783  
 25.00  
 10/4/18

Application for:  Local Permit \*  Charity Local Permit (one event per year)

Name of Non-profit Organization <b>The Village Family Service Center</b>	Date(s) of Activity 11/16/2018 to 11/16/2018	For a raffle, provide drawing date(s): NA	
Person Responsible for the Gaming Operation and Disbursement of Net Income <b>Jeff Pederson</b>	Title President/ceo	Business Phone Number (701) 451-4965	
Business Address 1201 25th St S	City Fargo	State ND	Zip Code 58103-1973
Mailing Address (if different) Po Box 9859	City Fargo	State ND	Zip Code 58106-9859
Name of Site Where Game(s) will be Conducted Holiday Inn of Fargo	Site Address 3803 13th Ave S		
City Fargo	State ND	Zip Code 58103-8992	County Cass
Check the Game(s) to be Conducted: * Poker, Twenty-one, and Paddlewheels may be Conducted only by a Charity Local Permit. <input type="checkbox"/> Bingo <input checked="" type="checkbox"/> Raffle <input checked="" type="checkbox"/> Raffle Board <input type="checkbox"/> Calendar Raffle <input type="checkbox"/> Sports Pool <input type="checkbox"/> Poker * <input type="checkbox"/> Twenty-one * <input type="checkbox"/> Paddlewheels *			

**DESCRIPTION AND RETAIL VALUE OF PRIZES TO BE AWARDED**

Game Type	Description of Prize	Retail Value of Prize
Paddle Game #1	West Acres g.c.	\$500.00
Paddle Game #2	West Acres g.c.	\$500.00
Raffle Board	Patron Bar Pckg	\$1,000.00
Raffle Board	HappyHarry g.c.	\$1,000.00
Raffle Board	Restaurant pack.	\$1,000.00
Raffle Board	Custom Table	\$1,700.00
Raffle Board	Purp. Rain Album	\$750.00
Raffle Board	NDSU Fire Pit	\$350.00

Game Type	Description of Prize	Retail Value of Prize
Raffle Board	Twins package	\$1,100.00
Raffle Board	Diamond Earring	\$4,000.00

(Limit \$12,000 per year)  
 Total: \$ 11,900.00

**Intended uses of gaming proceeds:** Benefiting services provided by The Village Family Service Center  
 including behavioral health services, mentoring and other programming in the FM region.

Does the organization presently have a state gaming license?  No  Yes - If "Yes," the organization is not eligible for a local permit or charity local permit and should call the Office of Attorney General at 1-800-326-9240.

Has the organization received a charity local permit from this or another city or county for the fiscal year July 1 through June 30?  No  Yes - If "Yes," the organization does not qualify for a local permit or charity local permit.

Has the organization received a local permit from this or another city or county for the fiscal year July 1 through June 30?  No  Yes - If "Yes," indicate the total value of all prizes previously awarded: \$ \_\_\_\_\_. This amount is part of the total prize limit of \$12,000 per year.

Signature of Organization's Top Executive Official 	Date 10-4-18	Title President/ceo	Business Phone Number (701) 451-4965
--	-----------------	------------------------	---

99



**APPLICATION FOR A LOCAL PERMIT OR CHARITY LOCAL PERMIT**  
 OFFICE OF ATTORNEY GENERAL  
 SFN 9338 (08/2016)

Application for:  Local Permit  Charity Local Permit (one event per year) *\* School year 2018-2019 multiple times*

Name of Non-profit Organization <b>Eagles Elementary PTA</b>		Date(s) of Activity 10/16/18 11/02/18 2/1/19 4/15/19		For a raffle, provide drawing date(s): n/a	
Person Responsible for the Gaming Operation and Disbursement of Net Income <i>Attn: Michelle Swanson</i>		Title <b>President</b>		Business Phone Number <b>701.261.4000</b>	
Business Address <b>3502 S. UNIVERSITY DRIVE</b>		City <b>Fargo</b>		State <b>ND</b>	Zip Code <b>58104</b>
Mailing Address (if different)		City		State	Zip Code
Name of Site Where Game(s) will be Conducted <b>Eagles Elementary</b>		Site Address <b>3502 S. UNIV. DR.</b>			
City <b>Fargo</b>		State <b>ND</b>	Zip Code <b>58104</b>	County <b>Cass</b>	
Check the Game(s) to be Conducted: * Poker, Twenty-one, and Paddlewheels may be Conducted only by a Charity Local Permit. <input checked="" type="checkbox"/> Bingo <input type="checkbox"/> Raffle <input type="checkbox"/> Raffle Board <input type="checkbox"/> Calendar Raffle <input type="checkbox"/> Sports Pool <input type="checkbox"/> Poker * <input type="checkbox"/> Twenty-one * <input type="checkbox"/> Paddlewheels *					

**DESCRIPTION AND RETAIL VALUE OF PRIZES TO BE AWARDED**

Game Type	Description of Prize	Retail Value of Prize	Game Type	Description of Prize	Retail Value of Prize
Bingo	IPAD	\$300			
Bingo	Inhomebook	\$200			
Bingo	trinkets / toys	nothing over \$5 value			
	candy / books				

\$1,000.00 Total: (Limit \$12,000 per year) \$ 1,000.00

Intended uses of gaming proceeds: The PTA will use the funds to support the students at Eagles Elementary in Fargo. They will be used to support the creation of a makerspace.

Does the organization presently have a state gaming license?  No  Yes - If "Yes," the organization is not eligible for a local permit or charity local permit and should call the Office of Attorney General at 1-800-326-9240.

Has the organization received a charity local permit from this or another city or county for the fiscal year July 1 through June 30?  No  Yes - If "Yes," the organization does not qualify for a local permit or charity local permit.

Has the organization received a local permit from this or another city or county for the fiscal year July 1 through June 30?  No  Yes - If "Yes," indicate the total value of all prizes previously awarded: \$ \_\_\_\_\_ . This amount is part of the total prize limit of \$12,000 per year.

Signature of Organization's Top Executive Official <i>Michelle Swanson</i>	Date <b>10/04/18</b>	Title <b>President</b>	Business Phone Number <b>701.261.4000</b>
---	-------------------------	---------------------------	--

10

**TO: BOARD OF CITY COMMISSIONERS**  
**FROM: EXECUTIVE ASSISTANT KEMBER ANDERSON** *KA*  
**DATE: OCTOBER 1, 2018**  
**SUBJECT: MEETING SCHEDULE FOR 2019**

I am proposing the following schedule for City Commission meetings for calendar year 2019 (please note, if a meeting day falls on a holiday, the meeting will be held on Tuesday).

- January 2 (Wednesday), January 14 and 28
- February 11 and 25
- March 11 and 25
- April 8 and 22
- May 6 and 20
- June 3 and 17
- July 1, 15 and 29
- August 12 and 26
- September 9 and 23
- October 7 and 21
- November 4 and 18
- December 2, 16 and 30

**RECOMMENDED MOTION:** To approve the 2019 City Commission meeting schedule as outlined above.

kamtgs19





(11)

Fargo City Commission  
200 3<sup>rd</sup> Street North  
Fargo, ND 58102

Commissioners:

The Fargo Dome Authority requests bid awards for FARGODOME Food & Beverage Paper Goods to Cole Paper and Dacotah Paper as per the attached summary. We solicited bids for supply items to commence at bid award through 12/31/2019 with the option for two one-year annual renewals at prices mutually agreeable to both parties. Additionally, in our bid documents we expressed our preference to award a majority of products to one vendor; however, we reserved the right to award specific products to other vendors due to pricing, brands, quality, or other relevant factors.

Upon review of the six bids we received, we were able to identify two vendors with the lowest costs on the majority of products. As noted in the attached summary, we generally awarded all items within a product "type" to the one company with the lowest overall cost. Minor instances in which a specific low bid was not from the company selected were nominal and not materially significant.

At their September 2018 meetings, the Fargo Dome Authority and their Finance/Building Committees approved the motion to award bids for FARGODOME Food & Beverage Paper Goods to Cole Paper and Dacotah Paper as per the attached summary.

Requested Motion: To approve the Bid Award for FARGODOME Food & Beverage Paper Goods to Cole Papers and Dacotah Paper as per the attached summary to commence at bid award through 12/31/2019 with the option for two one-year annual renewals at prices mutually agreeable to both parties.

Thank you for your consideration of this matter.

Very truly yours,

Rob Sobolik  
General Manager, FARGODOME

**Vendor:**

**"PAPER & PLASTIC PRODUCTS"**

	Cole Paper Co	Dacotah Paper
Cloverdale Hot Dog Bag - Foil		x
Cloverdale Napkins		x
Popcorn Tub - 85oz		3,744.40
Popcorn Tub - 46oz		1,528.54
White Full Fold Dispenser Napkins		1,828.20
Small 2 Compartment Nacho Tray		495.89
Plastic Fork - Heavy Weight		714.87
Plastic Knife - Heavy Weight		219.96
Clear Saddle Pack Hot Dog Bag		284.35
12" Bamboo Skewer		44.04
Hinged Lid Hot Dog Container - Foam		64.42
Quicksheets - Poly	91.48	
Jumbo Wrapped Straw - 7-3/4"	339.84	
2oz Souffle Lid - Clear	114.10	
2oz Souffle Cup - Clear	106.60	
3 lb. Polycoated Food Tray - Red Plaid	72.00	
1 lb. Polycoated Food Tray - Red Plaid	33.38	
4-Cup Carry Tray	1,694.42	

**"CUPS"**

Cold Cup - 24oz Translucent		5,233.62
Cold Cup - 5oz Translucent		735.56
Cold Cup - 21oz Double Sided Poly Paper		1,351.89
Cold Cup - 16oz Translucent		195.80
Clear Poly Tumblers - 10oz		95.85
Foam Cup - 12oz	611.73	
Foam Cup - 8oz	162.56	
Foam Cup - 12oz Insulated		471.87
Lid - White Hot Cup		156.08

**"SUPPLIES"**

Universal Poly Gloves		26.82
33 Gallon Can Liners - 33" x 40"		67.40
56 Gallon Can Liners - 43" x 48"		84.12
1 Gallon Distilled Water		150.42
146 Multi-Quat Sanitizer	143.64	
Foaming Grease Release Cleaner	53.04	
Degreaser - 32oz	46.78	
PanTastic Liquid Dishwash Detergent	82.40	

**"OTHER"**

Medium Yellow Popcorn	2,304.00	
	<b>\$5,855.97</b>	<b>\$17,494.10</b>

Total Estimated Annual Expense	<b>\$23,350.07</b>
2017 Estimated Annual Expense	<b>\$25,221.64</b>
Savings	<b>\$1,871.57</b>



12

October 2, 2018

Fargo City Commission  
225 4<sup>th</sup> Street North  
Fargo, ND 58102

Commissioners:

The Fargo Dome Authority requests your approval of the attached First Amendment to Agreement with Ovations Food Services, LP, dba Spectra Food Services & Hospitality. The amendment extends the term of the existing Agreement from December 31, 2018 to December 31, 2020. In 2015 a subcommittee of Fargo Dome Authority members selected Ovations as the organization to use for certain food and beverage services at FARGODOME with an initial term expiring on December 31, 2018. That initial Agreement allowed for one (1) – two (2) year extension, through December 31, 2020.

The terms of the proposed Amendment are financially advantageous to FARGODOME. Along with reduced fees in year two of the extended agreement (January 1, - December 31, 2020). City Attorney Erik Johnson, has reviewed the attached extension and indicated his acceptance of the language.

At their meeting held on September 25, 2018 the Fargo Dome Authority approved the attached First Amendment to Agreement.

Requested Motion: To approve the First Amendment to Agreement dated September 25, 2018 between Ovations Food Services, L.P. d/b/a Spectra Food Services & Hospitality and the Fargo Dome Authority, a duly constituted authority of the City of Fargo.

Thank you for your consideration of this matter.

Very truly yours,

Rob Sobolik  
General Manager, FARGODOME

Attachment

**First Amendment to Agreement**

This First Amendment to Agreement (the "Amendment") is entered into on September 25, 2018 and is between Ovations Food Services, L.P. d/b/a Spectra Food Services & Hospitality ("Spectra") and Fargo Dome Authority, a duly constituted authority of the City of Fargo, North Dakota ("Authority").

Background

Spectra and Authority are parties to that certain "Agreement" effective as of January 1, 2016 ("Agreement") and the parties desire to extend the term of such Agreement and amend its terms.

Accordingly, the parties agree as follows:

1. Capitalized terms used but not defined in this Amendment shall have the meanings assigned to such terms in the Agreement.
2. The term of the Agreement is hereby extended for an additional two (2) year period, expiring on December 31, 2020.
3. During the final Operating Year of the term (January 1, 2020 – December 31, 2020), the Base Fee shall be reduced to Three Thousand Dollars per month.
4. All references to the Agreement therein, or in any other document referencing the Agreement, shall be deemed to refer to the Agreement as amended hereby. Except for the modifications set forth above, all of the provisions of the Agreement shall remain unmodified and in full force and effect.
5. This Amendment shall be construed, interpreted and governed by the laws of the State of North Dakota.

*[signatures to follow on the next page]*



IN WITNESS WHEREOF, the parties hereto have duly executed this Amendment as of the date first written above.

**FARGODOME AUTHORITY**

**OVATIONS FOOD SERVICES, L.P. d/b/a  
SPECTRA FOOD SERVICES & HOSPITALITY  
By: Ovations Food Services, L.L.C., its  
general partner**

By:   
Name: TROY GOEROEN  
Title: FDA PRESIDENT

By:   
Name: Brian Rothmeier  
Title: President

**APPROVED BY:**

**CITY OF FARGO,  
a North Dakota municipal corporation**

By: \_\_\_\_\_  
Name:  
Title:

**ATTEST:**

By: \_\_\_\_\_  
Name:

13

**Finance Office**  
P.O. Box 2083  
200 3rd Street North  
Fargo, North Dakota 58107-2083  
Phone: 701-241-1333  
Fax: 701-241-1526

**TO: BOARD OF CITY COMMISSIONERS**  
**FROM: KENT COSTIN, DIRECTOR OF FINANCE** *KAC*  
**RE: STATE OF NORTH DAKOTA STATE COURT ADMINISTRATION CONTRACT**  
**DATE: OCTOBER 1, 2018**

The State Court Administrator drafted an updated contract in relation to court cases that are transferred to District Court. This contract updates the previous contract that expired in 2002.

The purpose of the contract draft is to assign fiscal responsibility for the cost of court cases transferred to District court in accordance with existing State Laws. It also describes the revenue sharing associated with these cases.

Shiloh Hanson, our Municipal Clerk of Court reviewed this agreement and recommends approval as drafted.

**Suggested Motion:**

Approve a court services contract with the State of North Dakota Court Administrator relating to cases transferred from Municipal Court to District Court.

**COURT SERVICES CONTRACT**  
(Transfer of Municipal Cases for Jury Trial)

1 This Agreement is made and entered into by and among the State of North Dakota (STATE), Cass  
2 County, North Dakota (COUNTY), and the City of Fargo (CITY).

**SECTION I - Division of Responsibilities and Fees**

3  
4 WHEREAS, N.D.C.C. § 40-18-15.1 requires transfer to District Court of municipal ordinance cases  
5 in which the defendant has requested in writing within 28 days after arraignment a transfer to District  
6 Court for a jury trial.

7 NOW, THEREFORE, the STATE, the COUNTY, and the CITY agree as follows:

- 8 1. [CITY] [COUNTY] shall provide the prosecuting attorney and pay all prosecution  
9 costs and expenses for all cases covered under this CONTRACT.
- 10 2. [CITY] [COUNTY] shall pay all indigent defense costs and expenses for all cases  
11 covered under this CONTRACT.
- 12 3. CITY shall pay any required transcript costs for all cases covered under this  
13 CONTRACT.
- 14 4. CITY shall pay for any necessary transportation and detention expenses for  
15 defendants in cases covered under this CONTRACT.
- 16  
17 5. COUNTY or STATE as appropriate, through the Clerk of District Court, shall  
18 provide for recording and management of all files and papers for cases transferred  
19 under this CONTRACT.

1           6.     STATE shall provide and pay for courtroom supplies, salaries of the district judge  
2                     and staff, office-related expenses, and jury expenses in the adjudication and  
3                     disposition of cases transferred under this CONTRACT.

4           7.     Except for mandatory administration fees imposed under state law and fee  
5                     assessments for funding crime victim and witness programs, all fees, fines, costs, and  
6                     forfeitures and any other monetary consideration collected from cases covered under  
7                     this Agreement, and any delinquent fines and costs, will be collected by the Clerk of  
8                     District Court and distributed in the following manner:

- 9
- 10           A.     CITY will receive 20% of all amounts collected.
- 11           B.     COUNTY will receive 20% of all amounts collected.
- 12           C.     STATE will receive 60% of all amounts collected.

13

14                     All amounts due the CITY, COUNTY, and STATE must be transmitted by the Clerk  
15                     of District Court to the CITY, COUNTY, and STATE on a quarterly basis. The  
16                     Clerk of District Court shall account to the CITY, COUNTY, and STATE for all  
17                     monies collected and distributed under this Contract.

18                                     **SECTION II - Term of Agreement**

19           The term of this Agreement is for one (1) year from May 29, 2018 through May 29, 2019 and  
20           continues thereafter from year-to-year unless a party to the CONTRACT gives written notice within  
21           at least ninety (90) days before the end of the contract period of the intention to terminate or seek  
22           modification of the CONTRACT.

23                                     **SECTION III - Separate Agreement between City and County**

24           An addendum agreement between the CITY and the COUNTY may be attached and incorporated  
25           as part of this CONTRACT.

1  
2  
3  
4  
5  
6  
7  
8  
9  
10  
11  
12  
13  
14  
15  
16  
17  
18  
19

**SECTION IV - Signatures**

IN WITNESS WHEREOF, the STATE, the COUNTY, and CITY, by and through the State Court Administrator, the Presiding Judge of the East Central Judicial District, the Cass County Board of Commissioners, and the City Council of Fargo execute this Contract.

**STATE OF NORTH DAKOTA:**

\_\_\_\_\_  
Date: \_\_\_\_\_  
Presiding District Judge  
\_\_\_\_\_  
Judicial District

\_\_\_\_\_  
Date: \_\_\_\_\_  
State Court Administrator

**CITY:**  
\_\_\_\_\_, Mayor  
Date: \_\_\_\_\_

\_\_\_\_\_, Auditor  
Date: \_\_\_\_\_

**COUNTY:**  
\_\_\_\_\_, Chair  
Date: \_\_\_\_\_  
Board of Commissioners



**Public Health**  
Prevent. Promote. Protect.  
Fargo Cass Public Health



**FARGO CASS PUBLIC HEALTH**  
1240 25th Street South  
Fargo, ND 58103-2367  
Phone 701-241-1360  
Fax 701-241-1366  
FargoCassPublicHealth.com

**M E M O R A N D U M**

**TO: BOARD OF CITY COMMISSIONERS**

**FROM: DESI FLEMING**  
**DIRECTOR OF PUBLIC HEALTH**

**DATE: OCTOBER 1, 2018**

**RE: CONTRACT WITH NORTH DAKOTA DEPARTMENT OF HEALTH**  
**FOR WIC PROGRAM FOR \$515,000**  
**CONTRACT NO. G17.998 CFDA NO. 10.557**

This is a request to approve the contract with the North Dakota Department of Health for the WIC program (Women, Infants, and Children).

No budget adjustment is required for this contract.

Please call me at 241-1380 if you have any questions.

**Suggested Motion:** Move to approve the contract with North Dakota Department of Health for the WIC program.

DF/LA  
Enclosure



		NOTICE OF GRANT AWARD SFN 53771 (1-2016)		NORTH DAKOTA DEPT. OF HEALTH (NDDoH) 600 E BOULEVARD AVE, DEPT. 301 BISMARCK, ND 58505-0200	
GRANT NUMBER	CFDA NAME	CFDA NUMBER	START DATE	END DATE	
G17.998	Special Supplemental Nutrition Program for Women, Infants, and Children	10.557	10/1/2018	9/30/2019	
FEDERAL AWARD DATE	FEDERAL AWARDING AGENCY	FAIN NUMBER	GRANT TYPE: PROGRAM or R&D		
	U.S. Department Of Agriculture		Program		
<b>THIS AWARD IS NOT EFFECTIVE AND EXPENDITURES RELATED TO THIS AWARD SHOULD NOT BE INCURRED UNTIL ALL PARTIES HAVE SIGNED THIS DOCUMENT.</b>					
TITLE OF PROJECT/PROGRAM	NDDoH PROJECT CODE				
GRANTEE NAME	PROJECT DIRECTOR				
ADDRESS	ADDRESS				
CITY/STATE/ZIP	CITY/STATE/ZIP				
CONTACT NAME	CONTACT NAME				
TELEPHONE NUMBER	TELEPHONE NUMBER				
EMAIL	EMAIL				
	NDDoH Cost Share	Grantee Cost Share	Total Costs		
Amount Awarded	\$515,000	\$0	\$515,000		
Previous Funds Awarded	\$0	\$0	\$0		
Total Funds Awarded	\$515,000	\$0	\$515,000		
SCOPE OF SERVICE	Grantee will make specific nutritionally desirable foods and nutrition education available for eligible pregnant women, infants and children within counties within the boundaries of the Grantee's service area in accordance with provisions of the Child Nutrition Act of 1966, 7 CFR, Part 246, FNS (and specific contract requirements noted in 246.6, see Attachment A), WIC Policy Memorandum and as detailed in the North Dakota WIC Policy and Procedure manuals. Grantee service provided and expenditures will follow the approved plan and budget. Any major changes in the type of service delivery and training must be submitted to the State Department of Health for prior approval.				
REPORTING REQUIREMENTS	Grantee must submit monthly expenditure reports via the Program Reporting System (PRS). Expenditure report for the period ending June 30, 2019 must be received by July 15, 2019. Final expenditure report for the period ending September 30, 2019, must be received by October 31, 2019. Reimbursement will be processed upon Department approval of state plan progress and expenditure reports.				
INDIRECT RATE (check one)	<input checked="" type="checkbox"/> Subrecipient waived indirect costs		De minimis rate of 10%		Negotiated/Approved rate of _____ %
SPECIAL CONDITIONS	None.				
This Notice of Grant Award is subject to the terms and conditions incorporated either directly or by reference in the following: (1) Requirements Addendum and Grantee Assurances for Notice of Grant Awards issued by the North Dakota Department of Health as signed by Grantee for the period of July 1, 2017 to June 30, 2019 [Accounting Use Only ___ Requirements received] and (2) applicable State and Federal regulations.					
EVIDENCE OF GRANTEE'S ACCEPTANCE			EVIDENCE OF NDDoH ACCEPTANCE		
DATE	SIGNATURE		DATE	SIGNATURE	
10/1/18	<i>Desi Fleming</i>				
TYPED NAME/TITLE OF AUTHORIZED REPRESENTATIVE			TYPED NAME/TITLE OF AUTHORIZED REPRESENTATIVE		
Desi Fleming, Director of Public Health			Colleen Pearce, Director, Division of Family Health and Nutrition		
DATE	SIGNATURE		DATE	SIGNATURE	
TYPED NAME/TITLE OF AUTHORIZED REPRESENTATIVE			TYPED NAME/TITLE OF AUTHORIZED REPRESENTATIVE		
Timothy J. Mahoney, Mayor, City of Fargo			Brenda M. Weisz, CFO		
If attachments are referenced, they must be returned with the signed award. If you did not receive attachments as indicated, contact the Program Director identified above.					



**Public Health**  
Prevent. Promote. Protect.  
Fargo Cass Public Health

15

**FARGO CASS PUBLIC HEALTH**  
1240 25th Street South  
Fargo, ND 58103-2367  
Phone 701-241-1360  
Fax 701-241-1366  
FargoCassPublicHealth.com

**M E M O R A N D U M**

**TO: BOARD OF CITY COMMISSIONERS**

**FROM: DESI FLEMING**  
**DIRECTOR OF PUBLIC HEALTH**

**DATE: SEPTEMBER 27, 2018**

**RE: CONTRACT WITH THE NORTH DAKOTA DEPARTMENT**  
**OF HEALTH FOR REGIONAL PUBLIC HEALTH**  
**NETWORK STRATEGIES**  
**CONTRACT NO. G17-988 CFDA NO. 93.758 \$10,000**

The attached grant agreement with the North Dakota Department of Health is for administrative duties related to the implementation of the Regional Public Health Network strategies for our region.

Please feel free to call me if you have any questions. No budget adjustment is required for this contract.

**Suggested Motion:** Move to approve the contract with the North Dakota Department of Health for Regional Public Health Network Implementation.

DF/la  
Enclosure





		NOTICE OF GRANT AWARD SFN 53771 (1-2016)		NORTH DAKOTA DEPT. OF HEALTH (NDDoH) 600 E BOULEVARD AVE., DEPT. 301 BISMARCK, ND 58505-0200	
GRANT NUMBER	CFDA NAME	START DATE	END DATE		
G17.988	Preventive Health and Health Services Block Grant funded solely with Prevention and Public Health Funds (PPHF)	10/1/2018	9/30/2019		
FEDERAL AWARD DATE	FEDERAL AWARDS AGENCY	GRANT TYPE: PROGRAM or R&D			
	Department Of Health And Human Services	Program			
THIS AWARD IS NOT EFFECTIVE AND EXPENDITURES RELATED TO THIS AWARD SHOULD NOT BE INCURRED UNTIL ALL PARTIES HAVE SIGNED THIS DOCUMENT.					
TITLE OF PROJECT/PROGRAM		NDDoH PROJECT CODE			
GRANTEE NAME		1151 HLH3148			
ADDRESS		Kelly Nagel			
CITY/STATE/ZIP		600 East Boulevard Avenue, Dept. 301			
CONTACT NAME		Bismarck, ND 58505			
TELEPHONE NUMBER		Kelly Nagel			
EMAIL		701-328-4596			
		kinagel@nd.gov			
Amount Awarded		Grantee Cost Share		Total Costs	
\$10,000		\$0		\$10,000	
Previous Funds Awarded		\$0		\$0	
Total Funds Awarded		\$10,000		\$10,000	
Grantee will perform administrative duties related to the implementation of the Southeast Public Health Collaborative work plan related to core public health services.					
Grantee will perform administrative duties related to the implementation of the Southeast Public Health Collaborative strategies. Funding will be utilized to implement strategies identified in the approved Southeast Public Health Collaborative work plan related to core public health services.					
Grantee will submit quarterly expenditure and progress reports in the Department's Program Reporting System. Expenditures for the period ending June 30, 2019 must be received by July 15, 2019. Final expenditure and progress report for the period ending September 30, 2019 must be received by October 30, 2019. Reimbursement will be processed upon Department approval of expenditures and progress report.					
Reporting Requirements:					
INDIRECT RATE (check one)		De minimis rate of 10%		Negotiated/Approved rate of %	
None		x			
SPECIAL CONDITIONS					
Evidence of Grant Award is subject to the terms and conditions incorporated either directly or by reference in the following: (1) Requirements Addendum and Grantee Assurances for Notice of Grant Awards issued by the North Dakota Department of Health as signed by Grantee for the period of July 1, 2017 to June 30, 2019 [Accounting Use Only Requirements received] and (2) applicable State and Federal regulations.					
DATE		SIGNATURE		EVIDENCE OF NDDoH ACCEPTANCE	
9/27/18		<i>Desi Fleming</i>			
TYPED NAME/TITLE OF AUTHORIZED REPRESENTATIVE		DATE		SIGNATURE	
Desi Fleming, Director of Public Health					
DATE		SIGNATURE		TYPED NAME/TITLE OF AUTHORIZED REPRESENTATIVE	
				Kelly Nagel, Director, Systems and Performance	
TYPED NAME/TITLE OF AUTHORIZED REPRESENTATIVE		DATE		SIGNATURE	
Timothy J. Mahoney, Mayor, City of Fargo					
If attachments are referenced, they must be returned with the signed award. If you did not receive attachments as indicated, contact the Program Director identified above.					



**Public Health**  
Prevent. Promote. Protect.  
Fargo Cass Public Health

16

**FARGO CASS PUBLIC HEALTH**  
1240 25th Street South  
Fargo, ND 58103-2367  
Phone 701-241-1360  
Fax 701-241-1366  
FargoCassPublicHealth.com

**M E M O R A N D U M**

**TO: BOARD OF CITY COMMISSIONERS**

**FROM: DESI FLEMING**  
**DIRECTOR OF PUBLIC HEALTH**

**DATE: SEPTEMBER 21, 2018**

**RE: AGREEMENT WITH LUTHERAN SOCIAL SERVICES OF**  
**NORTH DAKOTA FOR REFUGEE HEALTH SERVICES FOR**  
**\$8,000**

This is a request to approve the attached agreement with Lutheran Social Services of North Dakota for nurse case management for tuberculosis infection.

No budget adjustment is required for this contract.

If you have questions, please contact me at 241-1380.

**Suggested Motion:** Move to approve the contract agreement with Lutheran Social Services of North Dakota.

RR/LA  
Enclosure



GRANT AGREEMENT

Lutheran Social Services of North Dakota (Grantor), 3911 20<sup>th</sup> Avenue S, Fargo ND 58103, has determined the services identified in the Scope of Service paragraph below form an appropriate basis for the expenditure of federal funds allocated to Grantor.

Fargo Cass Public Health, 1240 25<sup>th</sup> Street S, Fargo ND 58103, is appropriate to provide those services.

Grantor and Grantee therefore enter into the following:

1. TERM OF GRANT

This grant runs from August 15, 2018 through August 14, 2019. This grant may be terminated at any time by mutual consent of both parties, or upon 30 days' written notice by either party, with or without cause.

2. SCOPE OF SERVICE, REPORTING, AND ADVISORY COMMITTEE

Grantee shall provide: Nurse Case Management and follow-up for Tuberculosis treatment, education, and outreach for ORR-eligible populations including refugees in its jurisdiction. Grantee shall provide semi-annual reports to Grantor on 3/1/2019 and 9/1/2019 in a format prescribed by the Office of Refugee Resettlement and Lutheran Social Services of ND as the grantee of federal funding. Grantee also shall collect data for reporting to the Office of Refugee Resettlement as requested by Grantor for the purpose of year end outcome measures. Nurse Case Management is to be provided in a linguistically appropriate manner utilizing written and spoken interpretation of materials of instruction and explanation when necessary.

The Grantee shall participate with other Grantees as a member of the Refugee Services Advisory Committee which meets at least quarterly, and will report to the committee on goals, outcomes, new initiatives, and barriers in providing health services to refugees.

3. COMPENSATION

Grantor, upon receipt and approval of Request for Reimbursement or other form required by Grantor, shall reimburse Grantee for allowable expenses incurred. "Allowable expenses" are defined by the OMB Circulars cited under Section 8 of this grant. The total amount paid under this grant may not exceed \$8,000. No funds will be paid for services until they have been provided. Grantee shall submit its request for reimbursement to Grantor monthly. Grantee shall submit its final reimbursement request to Grantor no later than 30 days after the expiration or termination of this grant. Grantor may not pay Grantee until Grantee signs and

returns to Grantor the Certification of the OMB Circular Information Guide.

Payment for services under this grant may include federal monies. Anticipated funding at the time this grant is executed is listed below. The funding source of actual payments and the federal program can be verified by contacting LSS' Fiscal Administration Division.

Anticipated Funding:

Federal	\$	8,000.00	Other	\$0.00
State		\$0.00	Unknown	\$0.00

Catalog of Federal Domestic Assistance Number 93.576, Department of Health and Human Services, Office of Refugee Resettlement, Health Promotion Funding.

4. GRANTEE'S UNDERSTANDING OF TERM OF FUNDING

Grantee understands that this grant is a one-time grant, and acknowledges that it has received no assurances that this grant may be extended beyond its expiration date.

5. GRANTEE ASSURANCES

Grantee agrees to comply with the applicable assurances set forth in the Grantee Assurances found in Attachment A which is part of this grant.

6. AUTHORITY TO CONTRACT

Grantee may not contract for or on behalf of, or incur obligations on behalf of, Grantor. Grantee may subcontract with qualified providers of services, provided that any subcontract acknowledges the binding nature of this grant, and incorporates this grant, together with its attachments as appropriate. Grantee agrees to be solely responsible for the performance of any subcontractor. Grantee may not assign or otherwise transfer or delegate any right or duty without Grantor's express written consent.

7. INDEPENDENT ENTITY

Grantee shall perform as an independent entity under this grant. Grantee, its employees, agents, or representatives are not employees of Grantor for any purpose, including the application of the Social Security Act, the Fair Labor Standards Act, the Federal Insurance Contribution Act, the Federal Unemployment Act, the North Dakota Unemployment Compensation Law, and the North Dakota Workers' Compensation Act. No part of this grant may be construed to represent the creation of an employer/employee relationship between Grantor and Grantee. Grantee will retain sole and absolute discretion in the judgment of the manner and means of carrying out Grantee's activities and responsibilities under this grant.

8. AUDIT RESPONSIBILITY AND EXPENSE ALLOWABILITY

Grantee agrees to keep financial records necessary to fully disclose the complete financial status of the grant. Grantee must submit documentation supporting requests for reimbursement for review by Grantor or its agents, upon request. If Grantee has expended federal funds (when considering all sources) during Grantee's fiscal year at the amount specified in OMB Circular A-133, Audits of State, Local Governments, and Non-Profit Organizations, which is made a part of this grant by reference here, that Circular must be followed pursuant to the Single Audit Act of 1984, Public Law 98-502; and the Single Audit Act Amendments of 1996, Public Law 104-156.

Grantee agrees to file a copy of the "Reporting Package" as described by the Circular referenced above with LSS' Fiscal Administration Division within the time frame identified in that Circular. Additionally, Grantee agrees to spend all federal assistance received from Grantor in accordance with applicable laws and regulations such as: OMB Circular A-110 Uniform Administrative requirements for Grants and Agreements with Institutions of Higher Education, Hospitals and other Non-Profit Organizations, OMB Circular A-122, the Cost Principals for Non-Profit Organizations, which are made a part of this grant by reference here.

9. RETENTION OF RECORDS

Grantee agrees to retain financial records for three years from the date of submission of the final expenditure report or if subject to audit, from the date the audit is completed and closed, whichever occurs later. Grantee must provide Grantor, the federal government, and their duly authorized representatives access to the books, documents, papers, and records of Grantee that are pertinent to the services provided under this grant. Program records must be maintained for a period of six years or until an audit is completed and closed, whichever occurs later.

10. TERMINATION OF GRANT FOR CAUSE

Grantor by written notice of default to Grantee may terminate all or any part of this grant if:

- a) Grantee fails to provide services required by this grant within the time specified or within any extension agreed to by Grantor; or
- b) Grantee fails to perform any of the other provisions of this grant, or fails to pursue the work in a way that endangers performance of this grant in accordance with its terms.

The rights and remedies of Grantor provided in the above clause related to defaults by Grantee are not exclusive and are in addition to any other rights and remedies provided by law or under this grant.

11. TERMINATION FOR LACK OF FUNDING OR AUTHORITY

Grantor may terminate this grant effective upon delivery of written notice to Grantee or on any later date stated in the notice, if:

- 1) Funding from federal, state, or other sources is not obtained and continued at levels sufficient to allow for purchase of the services or supplies in the indicated quantities or for the indicated term. The grant may be modified by mutual consent of the parties in writing to accommodate a reduction in funds.
- 2) Federal or state laws or rules are modified or interpreted in a way that the services are no longer allowable or appropriate for purchase under this grant or are no longer eligible for the funding proposed for payments authorized by this grant.
- 3) Any license, permit, or certificate required by law or rule, or by this grant, is for any reason denied, revoked, suspended or not renewed.

Any termination of this grant under this section is without prejudice to any obligations or liabilities of either party already accrued prior to termination.

12. CONTINGENT LIABILITY

During the term of this grant, and for three years after this grant expires or is terminated, Grantee agrees to reimburse Grantor for any claims submitted by Grantor for federal financial participation in the cost of this grant to the extent those claims are disallowed by any federal agency for failure on the part of Grantee to comply with this grant or any federal or state statutory or regulatory provisions which govern the source of funding. Grantor agrees to give Grantee prompt written notice of any disallowed claims subject to reimbursement by Grantee. Any amount disallowed as described is a debt owing to Grantor. Action may be brought by Grantor as allowed by law.

13. INDEMNITY

The Grantor and Grantee each agree to assume their own liability for any and all claims of any nature including all costs, expenses, and attorneys' fees which may in any manner result from or arise out of this agreement.

14. INSURANCE

The Grantor and Grantee each shall secure and keep in force during the term of this agreement, from any insurance company, government self-insurance pool or government self retention fund authorized to do business in North Dakota, commercial general liability with minimum limits of liability of \$250,000 per person and \$500,000 per occurrence.

15. NOTICE

Any notice or other communication required under this grant must be given by

registered or certified mail and is complete on the date mailed when addressed to the parties at the following addresses:

City of Fargo Fargo Cass Public Health 1240 25 <sup>th</sup> Street S Fargo, ND 58103	or	Lutheran Social Services of ND New Americans 3911 20 <sup>th</sup> Avenue S Fargo ND 58103
--	----	---

16. INTEGRATION, MODIFICATION, AND SEVERABILITY

This grant constitutes the entire grant between Grantee and Grantor. No alteration, amendment, or modification of this grant is effective unless it is reduced to writing, signed by the parties, and attached to the grant. If any term of this grant is declared by a court having jurisdiction to be illegal or unenforceable, the validity of the remaining terms will not be affected and, if possible, the rights and obligations of the parties are to be construed and enforced as if the grant does not contain the illegal or unenforceable term.

17. COLLATERAL CONTRACTS

If any inconsistency exists between this grant and other provisions of collateral contractual agreements that are made a part of this grant by reference or otherwise, the provisions of this grant control.

18. APPLICABLE LAW

This grant is governed by and construed according to the laws of the State of North Dakota.

19. ASSIGNMENT

Neither party may assign this grant or the party’s rights under this grant without the written approval of the other party. Approval to assign may not be unreasonably withheld. This grant is equally binding on the respective parties, and their successors and assigns.

20. WORK PRODUCT, EQUIPMENT, AND MATERIALS

All work product, equipment, and materials created or purchased under this grant belong to Grantor and must be delivered to Grantor at Grantor’s request upon expiration or termination of this grant. Grantee agrees that all materials prepared under this grant are “works for hire” within the meaning of copyright laws of the United States and assigns to Grantor all rights and interests Grantee may have in the materials it prepares under this grant, including any right to derivative use of the

material. Grantee shall execute all necessary documents to enable Grantor to protect its rights under this section. Grantor must provide written approval of Grantee's use of work product or materials for purposes outside the scope of this grant.

21. COMPLIANCE WITH PUBLIC RECORDS LAWS

The parties understand that records maintained under this grant may be subject to the provisions of North Dakota Century Code Chapter 44-04 relating to public records. Grantee further understands that any records or documents not considered to be public records under N.D.C.C. Chapter 44-04, including confidential records, shall not be disclosed without appropriate authorization. Grantor agrees not to disclose any information it may receive from grantee which grantee has identified as confidential and which grantor determines, in its sole discretion, is not subject to public disclosure under N.D.C.C. Chapter 44-04. The duties of the parties hereto to maintain confidentiality of information continues beyond the term of this grant, including any extensions or renewals.

22. DIRECT AND INDIRECT COSTS

The terms of this grant provide for an indirect rate. This rate is limited to the approved indirect rate. Grantee may claim such direct and indirect costs provided they are consistent with Federal OMB Circular A-122.

**LUTHERAN SOCIAL SERVICES OF NORTH DAKOTA**

\_\_\_\_\_  
Jessica Thomasson, CEO

\_\_\_\_\_  
Date

**CITY OF FARGO, FARGO CASS PUBLIC HEALTH**

  
\_\_\_\_\_  
, Director of Public Health

  
\_\_\_\_\_  
Date

\_\_\_\_\_  
Timothy J. Mahoney, Mayor, City of Fargo

\_\_\_\_\_  
Date

Grantee's Federal Taxpayer Identification Number 45-6002069



ATTACHMENT A

GRANTEE ASSURANCES

- A. In connection with furnishing supplies or performing work under this grant, persons who contract with or receive funds to provide services to Grantor are obligated and agree to comply with all local, state, and federal laws, regulations and executive orders related to the performance of this grant including the following: Fair Labor Standards Act, the North Dakota Human Rights Act, Equal Pay Act of 1963, Titles VI and VII of the Civil Rights Act of 1964, the Age Discrimination in Employment Act of 1967, the Comprehensive Alcohol Abuse and Alcoholism Prevention Treatment and Rehabilitation Act of 1970, the Drug Abuse Prevention, Treatment and Rehabilitation Act of 1970, Section 504 of the Rehabilitation Act of 1973, the Age Discrimination Act of 1975, Drug-free Workplace Act of 1988, the Americans with Disabilities Act of 1990, Alcohol, Drug Abuse and Mental Health Administration Reorganization Act of 1992 and the Pro-Children Act of 1994.
- B. Unless otherwise authorized by federal law, the charges to be made by Grantee do not include costs financed by federal monies other than those generated by this grant.
- C. By signing this grant, Grantee certifies that neither Grantee, Subcontractor, nor their principals, are presently debarred, declared ineligible, or voluntarily excluded from participation in transaction with State or Federal Government by any Department or Agency of the State or Federal Government.
- D. Grantee assures that:
  - 1) No federal funds from this agreement will be paid by or on behalf of Grantee, to any person for influencing or attempting to influence an officer or employee of any agency, a Member of Congress, an office or employee of Congress, or an employee of a Member of Congress in connection with the awarding of any Federal contract; the making of any Federal grant, the making of any Federal loan, the entering of any cooperative agreement; or the extension, continuation, renewal, amendment, or modification of any Federal contract, grant, loan, or cooperative agreement.
  - 2) If any grant funds other than Federal funds have been paid or will be paid to any person for influencing or attempting to influence an officer or employee of any agency, a Member of Congress, an office or employee of Congress or an employee of a Member of Congress in connection with this Federal contract, grant, loan or cooperative agreement, Grantee agrees to complete and submit Standard Form – LLL, “Disclosure Form to Report Lobbying,” in accordance with its instructions.

- 3) Grantee shall require that the language of the Grantee Assurances in this Attachment be included in the award documents for all sub-awards at all tiers (including subcontracts, sub-grants, and contracts under grants, loans, and cooperative agreements) and that all sub-recipients shall comply with these Grantee Assurances.



**Public Health**  
Prevent. Promote. Protect.  
Fargo Cass Public Health

17

**FARGO CASS PUBLIC HEALTH**  
1240 25th Street South  
Fargo, ND 58103-2367  
Phone 701-241-1360  
Fax 701-241-1366  
**FargoCassPublicHealth.com**

**M E M O R A N D U M**

**TO: BOARD OF CITY COMMISSIONERS**

**FROM: DESI FLEMING**  
**DIRECTOR OF PUBLIC HEALTH**

**DATE: SEPTEMBER 25, 2018**

**RE: AGREEMENT FOR SERVICES WITH CHILD CARE AWARE® OF**  
**NORTH DAKOTA FOR \$10,000**

The attached contract with Child Care Aware® of North Dakota is to provide training opportunities to licensed child care center staff to meet annual health code training requirements.

If you have any questions, please contact me at 241-1380.

**Suggested Motion:** Move to approve the Agreement for Services with Child Care Aware® of North Dakota

DF/LA  
Enclosure



**AGREEMENT FOR SERVICES**

**THIS AGREEMENT**, effective the 1st day of October, 2018, by and between Fargo Cass Public Health ("FCPH"); and Child Care Aware® of North Dakota.

**NOW, THEREFORE**, it is hereby agreed by and between the parties hereto as follows:

- A. **Term of Agreement:** The parties entered into a written agreement for the period of October 1, 2018, through September 30, 2019.
- B. **Services to be provided by independent contractor:** Child Care Aware® of North Dakota will work with Fargo Cass Public Health by providing training opportunities for City of Fargo and West Fargo licensed Child Care center staff to meet their annual health code training requirements. Duties will include: administering the Step 2 Promoting Wellness e-learning modules, and facilitating Training-To-Go requests from licensed Fargo and West Fargo child care centers.
- C. **Reimbursement:** The contracting consultant shall be reimbursed a contract total of \$10,000.00, and submit a monthly invoice. The contract will not to exceed \$10,000.00.
- D. **Termination:** This Agreement may be terminated by either party upon the giving of thirty (30) days written notice.
- E. **Confidentiality:** The contracting consultant agrees to not, directly or indirectly, disclose, make known, divulge, publish or communicate any individually identifiable health information or other confidential information to any person, firm or corporation without consent unless that disclosure is authorized under North Dakota law.

**Special Considerations:**

- A. It is understood and agreed that the relationship created by this Agreement shall be that of independent contractor and contractee shall not be deemed to be an employee of Fargo Cass Public Health for any other purpose.
- B. This service agreement shall be governed by the laws of the State of North Dakota. I hereby certify that the above assurances and provisions of service have been reviewed and our agency has agreed upon the conditions as set forth.
- C. It is understood any forms or paperwork required by Fargo Cass Public Health and the City of Fargo to receive payment for services will be completed as needed.

**In Witness** thereof, this purchase of service agreement has been executed between the Consultant and Fargo Cass Public Health on the date-executed below.

**FARGO CASS PUBLIC HEALTH**

**CONSULTANT**

By *Ruth Roman*  
Ruth Roman  
Director of Public Health

By *Jessica Thomasson*  
Jessica Thomasson  
Director of Child Care Aware of ND

Date 9/25/18

Date \_\_\_\_\_

By \_\_\_\_\_  
Timothy J. Mahoney, Mayor, City of Fargo

Date \_\_\_\_\_



**Public Health**  
Prevent. Promote. Protect.  
Fargo Cass Public Health

18

**FARGO CASS PUBLIC HEALTH**  
1240 25th Street South  
Fargo, ND 58103-2367  
Phone 701-241-1360  
Fax 701-241-1366  
FargoCassPublicHealth.com

**MEMORANDUM**

**TO: BOARD OF CITY COMMISSIONERS**

**FROM: DESI FLEMING**  
**DIRECTOR OF PUBLIC HEALTH**

**DATE: SEPTEMBER 24, 2018**

**RE: CONTRACT WITH NORTH DAKOTA DEPARTMENT OF HEALTH**  
**FOR INCREASING BREASTFEEDING RATES/REDUCING**  
**OVERWEIGHT AND OBESITY PROGRAM**  
**CONTRACT NO. G17.973 CFDA NO. 93.994, \$120,000**

The attached contract with the North Dakota Department of Health is to increase breastfeeding rates and reduce overweight and obesity in children in Cass County. Total contract is \$210,000 of which \$120,000 is Federal and \$90,000 is local match fulfilled by current staff salary and benefits.

No budget adjustments are need for this contract.

If you have any questions, please call me at 241-1380.

**Suggested Motion:** Move to approve the contract with North Dakota Department of Health for increasing breastfeeding and reducing childhood obesity.

DF/LA  
Enclosure



		NOTICE OF GRANT AWARD SFN 53771 (1-2016)		NORTH DAKOTA DEPT. OF HEALTH (NDDoH) 600 E BOULEVARD AVE, DEPT. 301 BISMARCK, ND 58505-0200	
GRANT NUMBER	CFDA NUMBER	START DATE	END DATE		
G17.973					
FEDERAL AWARD DATE	FEDERAL AWARING AGENCY				
11/7/2017	Department Of Health And Human Services	10/1/2018	9/30/2019		
THIS AWARD IS NOT EFFECTIVE AND EXPENDITURES RELATED TO THIS AWARD SHOULD NOT BE INCURRED UNTIL ALL PARTIES HAVE SIGNED THIS DOCUMENT.					
TITLE OF PROJECT/PROGRAM	Increasing Breastfeeding Rates/Reducing Overweight/Obesity				
GRANTEE NAME	Fargo Cass Public Health				
ADDRESS	1240 25th Street South				
CITY/STATE/ZIP	Fargo, ND 58103-2367				
CONTACT NAME	Larry Anenson				
TELEPHONE NUMBER	701.241.8575				
EMAIL	Lanenson@FargoND.gov				
	NDDoH Project Code	4561 HLH3138 05			
	PROJECT DIRECTOR	Mikaela Schlosser, Sarah Massey			
	ADDRESS	600 E. Boulevard Ave., Dept. 301			
	CITY/STATE/ZIP	Bismarck, ND 58505-0200			
	CONTACT NAME	Mikaela Schlosser, Sarah Massey			
	TELEPHONE NUMBER	701.328.4529, 701.328.2722			
	EMAIL	mlschlosser@nd.gov, smassey@nd.gov			
Amount Awarded	Grantee Cost Share	Total Costs			
\$120,000	\$90,000	\$210,000			
Previous Funds Awarded	\$0	\$0			
Total Funds Awarded	\$120,000	\$210,000			
Grantee agrees to carry out: 1) a program to increase breastfeeding rates at 6 months and 2) a program to reduce overweight and obesity in children in Cass County, in accordance with the objectives, strategies and activities, stated in the action plan submitted by the Grantee dated August 24, 2018.					
SCOPE OF SERVICE					
Reimbursement will be processed upon Department approval of expenditure, data and progress reports. Reporting Requirements are further defined in Attachment A.					
REPORTING REQUIREMENTS					
Indirect Rate (check one)					
<input checked="" type="checkbox"/> Subrecipient waived indirect costs		De minimis rate of 10%		Negotiated/Approved rate of _____ %	
SPECIAL CONDITIONS					
This Notice of Grant Award is subject to the terms and conditions incorporated either directly or by reference in the following: (1) Requirements Addendum and Grantee Assurances for Notice of Grant Awards issued by the North Dakota Department of Health as signed by Grantee for the period of July 1, 2017 to June 30, 2019 [Accounting Use Only Requirements received] and (2) applicable State and Federal regulations.					
EVIDENCE OF GRANTEE'S ACCEPTANCE			EVIDENCE OF NDDoH ACCEPTANCE		
DATE	SIGNATURE	DATE	SIGNATURE		
9/24/18	<i>Desi Fleming</i>				
TYPED NAME/TITLE OF AUTHORIZED REPRESENTATIVE					
Desi Fleming, Director of Public Health			Colleen Pearce, Director, Division of Family Health and Nutrition		
DATE					
SIGNATURE			SIGNATURE		
TYPED NAME/TITLE OF AUTHORIZED REPRESENTATIVE					
Timothy J. Mahoney, Mayor, City of Fargo			Brenda M. Weisz, CFO		
If attachments are referenced, they must be returned with the signed award. If you did not receive attachments as indicated, contact the Program Director identified above.					



**Public Health**  
Prevent. Promote. Protect.  
Fargo Cass Public Health

19

**FARGO CASS PUBLIC HEALTH**  
1240 25th Street South  
Fargo, ND 58103-2367  
Phone 701-241-1360  
Fax 701-241-1366  
FargoCassPublicHealth.com

**M E M O R A N D U M**

**TO: BOARD OF CITY COMMISSIONERS**

**FROM: DESI FLEMING**  
**DIRECTOR OF PUBLIC HEALTH**

**DATE: OCTOBER 3, 2018**

**RE: AMERICAN LUNG ASSOCIATION AGREEMENT FOR**  
**SERVICES FOR TOBACCO PREVENTION ACTIVITIES FOR**  
**\$22,500 (RFP 18257)**

The following Agreement for Services with American Lung Association is for tobacco prevention activities. No budget adjustment is required for this contract.

If you have any questions, please contact me at 241-1380.

**Suggested Motion:** Move to approve the contract with American Lung Association for tobacco prevention activities.

DF/LA  
Enclosure



## AGREEMENT FOR SERVICES

**THIS AGREEMENT**, effective the 24<sup>th</sup> day of September 2018 by and between Fargo Cass Public Health (FCPH); and the American Lung Association (Contractor).

**NOW, THEREFORE**, it is hereby agreed by and between the parties here to as follows:

1. **Term of Agreement:** The parties entered into a written agreement for the period of September 24, 2018 through June 30, 2019.
  - A. **Services to be provided by independent contractor:** Working in collaboration with FCPH, the independent contractor will function as the Project Manager in implementing tobacco prevention, control, and cessation activities to reduce tobacco-related disparities and social norms among specific population groups. Duties will include: assess beliefs and attitudes about tobacco use/development/treatment among shelter staff and individuals who are experiencing homelessness, determine potential messaging to increase interest in tobacco treatment among shelter staff and individuals experiencing homelessness, and produce audio/visual/print materials to educate staff/volunteers and individuals who are experiencing homelessness. In addition, determine readiness for action on programming/advocacy/systems change toward increasing tobacco treatment opportunities, and provide technical assistance to shelters and homeless advocates so they have the tools to implement these actions.
  - B. **Reimbursement:** The contracting consultant shall be reimbursed up to \$22,500, including: staff time, incentives for participants, supplies, and travel expenses. Invoices must be submitted monthly by the 7<sup>th</sup> of following month with Progress Reports with the final invoice being due on June 14, 2019.
  - D. **Termination:** This Agreement may be terminated by either party upon the giving of thirty (30) days written notice.
  - E. **Confidentiality:** The independent contracting consultant agrees to not, directly or indirectly, disclose, make known, divulge, publish or communicate any individually identifiable health information or other confidential information to any person, firm or corporation without consent unless that disclosure is authorized under North Dakota law.
  - F. **Progress Reports:** FCPH, shall throughout the effective dates of this agreement, conduct ongoing evaluation of the Contractor's performance in carrying out their tobacco prevention, control, and cessation services. Such evaluation may include, but not be limited to periodic visits by departmental representatives to review progress made by Contractor in accomplishing stated goal/objectives. Contractor will submit written reports and forms provided by FCPH. Progress reports shall be submitted by the 7<sup>th</sup> day of the following month, beginning November 7<sup>th</sup> for October 2018 with the final report due in July 2019.



**Special Considerations:**

- A. It is understood and agreed that the relationship created by this Agreement shall be that of independent contractor and contractee that shall not be deemed an employee of FCPH for any other purpose.
- B. The laws of the State of North Dakota shall govern this service agreement. I hereby certify that the above assurances and provisions of service have been reviewed and our agency has agreed upon the conditions as set forth.
- C. It is understood any forms or paperwork required by FCPH and the City of Fargo to receive payment for services will be completed as needed.

**In Witness** thereof, this purchase of service agreement has been executed between the Consultant and Fargo Cass Public Health on the date-executed below.

**FARGO CASS PUBLIC HEALTH**

**CONSULTANT**

By Desi Fleming  
 Desi Fleming  
 Director of Public Health

By Shirley Brown  
 American Lung Association

Date 10/3/18

Date 10/2/18

By \_\_\_\_\_  
 Timothy J. Mahoney  
 Mayor, City of Fargo

Date \_\_\_\_\_



**Public Health**  
Prevent. Promote. Protect.  
Fargo Cass Public Health

20

**FARGO CASS PUBLIC HEALTH**  
1240 25th Street South  
Fargo, ND 58103-2367  
Phone 701-241-1360  
Fax 701-241-1366  
FargoCassPublicHealth.com

**M E M O R A N D U M**

**TO: BOARD OF CITY COMMISSIONERS**

**FROM: DESI FLEMING**  
**DIRECTOR OF PUBLIC HEALTH**

**DATE: OCTOBER 3, 2018**

**RE: SHAREHOUSE AGREEMENT FOR SERVICES FOR TOBACCO**  
**PREVENTION ACTIVITIES FOR \$18,377.30 (RFP 18257)**

The following Agreement for Services with ShareHouse is for tobacco prevention activities. No budget adjustment is required for this contract.

If you have any questions, please contact me at 241-1380.

**Suggested Motion:** Move to approve the contract with ShareHouse for tobacco prevention activities.

DF/LA  
Enclosure



## AGREEMENT FOR SERVICES

**THIS AGREEMENT**, effective the 24<sup>th</sup> day of September 2018 by and between Fargo Cass Public Health (FCPH); and ShareHouse (Contractor).

**NOW, THEREFORE**, it is hereby agreed by and between the parties here to as follows:

1. **Term of Agreement:** The parties entered into a written agreement for the period of September 24, 2018 through June 30, 2019.
  - A. **Services to be provided by independent contractor:** Working in collaboration with FCPH, the independent contractor will function as the Project Manager in implementing tobacco prevention, control, and cessation activities to reduce tobacco-related disparities and social norms among specific population groups. Duties will include: assess for need, offer stage-appropriate counseling for tobacco cessation services while offering education and engagement groups for motivation enhancement, and implement alternative activities in place of smoke breaks. Additionally, staff will attend trainings to acquire relevant information and skills to effectively dose nicotine replacement therapy and work towards becoming completely tobacco free by July 1, 2019 at all ShareHouse locations in Fargo, North Dakota. All data collected will be property of FCPH.
  - B. **Reimbursement:** The contracting consultant shall be reimbursed up to \$18,377.30, including nicotine replacement therapy, alternative activities in place of tobacco breaks, continuing education, carbon monoxide detector, and travel expenses. An initial \$5,000 shall be granted to purchase nicotine replacement therapy for individuals who are uninsured with additional funds available for NRT, if needed. All nicotine replacement therapy medication must be approved by the Food and Drug Administration and individual's medical provider, including nicotine patches, nicotine gum, and nicotine lozenges. Invoices must be submitted monthly by the 7<sup>th</sup> of following month with Progress Reports with the final invoice being due on June 14, 2019.
  - D. **Termination:** This Agreement may be terminated by either party upon the giving of thirty (30) days written notice.
  - E. **Confidentiality:** The independent contracting consultant agrees to not, directly or indirectly, disclose, make known, divulge, publish or communicate any individually identifiable health information or other confidential information to any person, firm or corporation without consent unless that disclosure is authorized under North Dakota law.
  - F. **Progress Reports:** FCPH, shall throughout the effective dates of this agreement, conduct ongoing evaluation of the Contractor's performance in carrying out their tobacco prevention, control, and cessation services. Such evaluation may include, but not be limited to periodic visits by departmental representatives to review progress made by Contractor in accomplishing stated goal/objectives. Contractor will submit written reports and forms provided by FCPH. Progress reports shall be submitted by the 7<sup>th</sup> day of the following month, beginning November 7<sup>th</sup> for October 2018 with the final report due July 2019.

**Special Considerations:**

- A. It is understood and agreed that the relationship created by this Agreement shall be that of independent contractor and contractee that shall not be deemed an employee of FCPH for any other purpose.
- B. The laws of the State of North Dakota shall govern this service agreement. I hereby certify that the above assurances and provisions of service have been reviewed and our agency has agreed upon the conditions as set forth.
- C. It is understood any forms or paperwork required by FCPH and the City of Fargo to receive payment for services will be completed as needed.

**In Witness** thereof, this purchase of service agreement has been executed between the Consultant and Fargo Cass Public Health on the date-executed below.

**FARGO CASS PUBLIC HEALTH**

**CONSULTANT**

By   
 Desi Fleming  
 Director of Public Health

By  (Ty Heglund, President/CEO)  
 ShareHouse

Date \_\_\_\_\_

Date 10-02-2018

By \_\_\_\_\_  
 Timothy J. Mahoney  
 Mayor, City of Fargo

Date \_\_\_\_\_



**Public Health**  
Prevent. Promote. Protect.  
Fargo Cass Public Health

**FARGO CASS PUBLIC HEALTH**  
1240 25th Street South  
Fargo, ND 58103-2367  
Phone 701-241-1360  
Fax 701-241-1366  
FargoCassPublicHealth.com

21

**M E M O R A N D U M**

**TO: BOARD OF CITY COMMISSIONERS**

**FROM: DESI FLEMING**  
**DIRECTOR OF PUBLIC HEALTH**

**DATE: OCTOBER 3, 2018**

**RE: SOUTHEAST HUMAN SERVICE CENTER AGREEMENT FOR**  
**SERVICES FOR TOBACCO PREVENTION ACTIVITIES FOR**  
**\$51,000 (RFP 18257)**

The following Agreement for Services with Southeast Human Service Center is for tobacco prevention activities. No budget adjustment is required for this contract.

If you have any questions, please contact me at 241-1380.

**Suggested Motion:** Move to approve the contract with Southeast Human Service Center for tobacco prevention activities.

DF/LA  
Enclosure



## AGREEMENT FOR SERVICES

**THIS AGREEMENT**, effective the 24<sup>th</sup> day of September 2018 by and between Fargo Cass Public Health (FCPH); and Southeast Human Service Center (Contractor).

**NOW, THEREFORE**, it is hereby agreed by and between the parties here to as follows:

1. **Term of Agreement:** The parties entered into a written agreement for the period of September 24, 2018 through June 30, 2019.
  - A. **Services to be provided by independent contractor:** Working in collaboration with FCPH, the independent contractor will function as the Project Manager in implementing tobacco prevention, control, and cessation activities to reduce tobacco-related disparities and social norms among specific population groups. Duties will include: group and individual counseling for tobacco cessation services, implement alternative activities in place of smoke breaks, attend trainings to acquire relevant information and skills to properly dose nicotine replacement therapy, and work towards becoming completely tobacco free by July 1, 2019 at all Southeast Human Service Center locations in Fargo, North Dakota.
  - B. **Reimbursement:** The contracting consultant shall be reimbursed up to \$51,000, including nicotine replacement therapy, carbon monoxide testers and supplies, continuing education, and travel expenses. An initial \$10,000 shall be granted to purchase nicotine replacement therapy for individuals who are uninsured for quarter three (January-March) with additional funds available for NRT, if needed. All nicotine replacement therapy medication must be approved by the Food and Drug Administration and individual's medical provider, including nicotine patches, nicotine gun, and nicotine lozenges. Invoices must be submitted monthly by the 7<sup>th</sup> of following month with Progress Reports with the final invoice being due on June 14, 2019.
  - D. **Termination:** This Agreement may be terminated by either party upon the giving of thirty (30) days written notice.
  - E. **Confidentiality:** The independent contracting consultant agrees to not, directly or indirectly, disclose, make known, divulge, publish or communicate any individually identifiable health information or other confidential information to any person, firm or corporation without consent unless that disclosure is authorized under North Dakota law.
  - F. **Progress Reports:** FCPH, shall throughout the effective dates of this agreement, conduct ongoing evaluation of the Contractor's performance in carrying out their tobacco prevention, control, and cessation services. Such evaluation may include, but not be limited to periodic visits by departmental representatives to review progress made by Contractor in accomplishing stated goal/objectives. Contractor will submit written reports and forms provided by FCPH. Progress reports shall be submitted by the 7<sup>th</sup> day of the following month, beginning November 7<sup>th</sup> for October 2018 with the final report due July 2019.

**Special Considerations:**

- A. It is understood and agreed that the relationship created by this Agreement shall be that of independent contractor and contractee that shall not be deemed an employee of FCPH for any other purpose.
- B. The laws of the State of North Dakota shall govern this service agreement. I hereby certify that the above assurances and provisions of service have been reviewed and our agency has agreed upon the conditions as set forth.
- C. It is understood any forms or paperwork required by FCPH and the City of Fargo to receive payment for services will be completed as needed.

In Witness thereof, this purchase of service agreement has been executed between the Consultant and Fargo Cass Public Health on the date-executed below.

**FARGO CASS PUBLIC HEALTH**

**CONSULTANT**

By *Desi Fleming*  
 Desi Fleming  
 Director of Public Health

By *Shawn J. [Signature]*  
 Southeast Human Service Center

Date \_\_\_\_\_

Date 10-2-18

By \_\_\_\_\_  
 Timothy J. Mahoney  
 Mayor, City of Fargo

Date \_\_\_\_\_

22

To: Board of City Commissioners  
From: Jill Minette, Director of Human Resources  
Re: 2019 Benefit Renewals  
Date: October 4, 2018

We have several benefit plan renewals that will be occurring on January 1, 2019. The renewals and proposed changes are listed below:

Health Insurance

Our health insurance provider is Blue Cross Blue Shield of North Dakota (BCBSND). Their proposed renewal for the BlueAccess Grandfathered Plan for 2019 includes a 7% premium increase. This equates to a monthly increase of \$4.12 for employees enrolled in single and a monthly increase of \$19.90 for employees enrolled in family. The City of Fargo contribution will increase by approximately \$373,179 in 2019, which was included in the 2019 budget. The proposed health premiums are attached. The plan design (deductibles, co-payments and out-of-pocket maximums) remains essentially the same with only a few changes to items such as precertification, pediatric wellness services, etc. as outlined in the attached Summary of Benefit Plan Changes for Group Health Plans.

A non-grandfathered plan was explored as a part of the renewal process. While a non-grandfathered plan would provide enhanced wellness benefit coverage, the 11% premium increase is beyond the 7% approved in the 2019 budget. We will continue to explore enhanced benefit options during the 2020 renewal.

Dental Insurance

Our dental insurance provider is Blue Cross Blue Shield of North Dakota (BCBSND). Their proposed renewal for 2019 includes a 2% decrease to premiums. The City contributes the cost of the single premium for all full-time employees (pro-rated for benefited employees scheduled less than 40 hours per week) regardless of the level of coverage elected. The proposed dental premiums are attached. The premium decrease results in an approximate decrease of \$9,802 to the City of Fargo. Employees who have elected family coverage will experience a decrease of \$1.70 per month.

We accepted proposals for the dental plan due to the BCBSND provider reimbursement change, which resulted in a decrease of participating providers in the area; however, through the proposal process, BCBSND submitted the lowest premium structure by at least \$10.42 per month at the family level. The lower premiums offered by BCBSND will help enrollees offset expenses incurred at non-participating providers.



Vision Insurance

Our vision insurance provider is currently Avesis. We accepted proposals and are recommending Superior Vision as our vision insurance provider in 2019. The Superior Vision Plan provides enhanced benefits and an expanded network along with a 12% reduction in premiums. The lower premiums are guaranteed for four years, until December 31, 2022.

Life Insurance

Our current life insurance provider is Mutual of Omaha. The life insurance renewal for 2019 provides no increase to employee premiums, which are paid entirely by COF employees. This rate is guaranteed until December 31, 2019.

Long-Term Disability Insurance

Our current long-term disability provider is Mutual of Omaha. There is no change to the plan, which has an elimination period 120 days. The City of Fargo pays the LTD premium of .20% of insured income entirely.

Short-Term Disability Insurance

In conjunction with BlueConnect, the benefit enrollment platform, we will be offering an individual short-term disability plan through Unum. The plan will be voluntary and the premium will be paid entirely by participating employees. The plan has an elimination period of 14 days and a benefit period of six months at 60% of base income. The benefit will be offered during our annual benefit enrollment and will go into effect in January 2019.

Flexible Spending Accounts

The City of Fargo will continue to offer employees the opportunity to participate in flexible benefits administered by Discovery Benefits. Participants utilize pre-tax dollars to pay for eligible health and dependent care expenses.

457 Deferred Compensation

We would like to begin offering FTJ Fund Choice as another option for 457 Deferred Compensation retirement savings as of January 2019. The local representative for VOYA would also serve as the representative for FTJ Fund Choice.

In addition, we would like to begin offering a Roth 457 option for post-tax retirement savings with ICMA. Both of these recommended 457 changes provided additional retirement savings for our employees.

**RECOMMENDED MOTION: To approve the benefit renewals as outlined in this benefit renewal memo effective January 1, 2019.**



## Summary of Benefit Plan Changes for Group Health Plans

The following information is intended to provide a brief summary of your benefit plan changes effective January 1, 2019. It should not be used to determine whether your health care expenses will be paid. The written benefit plan governs the benefits available. Covered services are subject to your benefit plan cost sharing amounts, unless otherwise indicated.

This is a grandfathered benefit plan under the Patient Protection and Affordable Care Act (PPACA).

### Appeal Address Change

A member or the member's authorized representative may submit or return an appeal by contacting Member Services at Blue Cross Blue Shield of North Dakota, P.O. Box 1570, Fargo, ND 58107-1570 or telephone (the phone number on the back of your health identification card). Appeals were previously sent to a street address.

### Psychiatric and Substance Abuse Services Inpatient Precertification

Blue Cross Blue Shield of North Dakota (BCBSND) changed its payment methodology for psychiatric and substance abuse services to model the same payment methodology as inpatient hospital and medical services. Because of this change, BCBSND is modifying language in the benefit plan book to clarify precertification requirements and have them match those of inpatient hospital and medical services.

### Wellness Services

Language has changed from well child care to pediatric preventive visits. The number of covered visits available for specific age ranges has been recategorized to better serve members:

- 11 visits for members from birth through 35 months
- 1 visit per benefit period (calendar year) for members age 3 through age 6

Pediatric preventative immunizations have been changed to through age 6.

The age restriction for preventive screening services for members has changed from age 6 and older to age 7 and older.

### Premium Refund

Language has been updated for a premium refund. The premium refund will be prorated based on the exact date of death, in the event of a member's death. Refunds were previously based on a half month or full month.

### Effective Date for Dependent Coverage

Language has been updated for adding a dependent to the health plan. The effective date of coverage for adding dependents to a benefit plan will be the exact date of birth, physical placement or court order. The previous effective date was the first or sixteenth of the month preceding the date.

### **Home Health Care**

Language has been revised for the definition of Home Health Care.

Home Health Care – skilled nursing services, physical therapy, occupational therapy and speech therapy provided under active physician and nursing management through a central administrative unit coordinated by a registered nurse to an essentially homebound member in the member's place of residence.

### **Managed Benefits/Notification Requirements**

Language has been updated for the following definitions:

- Precertification is the new term for preauthorization and prior approval
- Authorizations is the new term for managed benefits

### **Class of Coverage Change**

Language for the class of coverage has been updated. The new term for class of coverage is contract type. The contract types have been expanded and defined:

- Individual Coverage – Subscriber only.
- Parent and Child Coverage – Subscriber and one eligible child.
- Parent and Children Coverage – Subscriber and eligible children.
- Two Person Coverage – Subscriber and spouse.
- Family Coverage – Subscriber and eligible dependents.

### **Outpatient Rehabilitative Therapy Services**

Language has been changed for rehabilitative occupational and speech therapy to remove the reference to a 90-day benefit limit. The services will now have the same benefit application as rehabilitative physical therapy.

### **Cardiac Rehabilitation Services**

Language has been updated to remove the maximum benefit allowance of 30 visits per episode for cardiac rehabilitation services.

### **Nonparticipating Health Care Providers within the State of North Dakota**

When a member residing in North Dakota receives covered services from a nonparticipating health care provider within the state, the 20 percent reduction will no longer apply to the benefit payment for the covered services. Any charges in the excess of the allowance will continue to apply.

### **Benefit Plan Attachment**

The benefit plan attachment, previously sent with the identification card, is being discontinued; the benefit plan attachment has been removed as a definition. The information contained on the benefit plan attachment will be supplied in a different form moving forward. For example, the Certificate of Insurance (benefit plan) will contain cost sharing amounts.

### **Non-Discrimination Notice**

An additional protective measure has been added to the non-discrimination notice to ensure the privacy of members: *Communication by unencrypted email presents a risk.*

### **Nonparticipating Health Care Providers in a Participating Health Care Provider Setting**

Covered services including anesthesiology, radiology, or pathology have been expanded when services are received from a nonparticipating health care provider in an in-network setting. The covered services will be paid at the in-network level, and reimbursement will be based on the allowance. Any charges in excess of the allowance will continue to apply.

### **Benefit Plan Number**

The term benefit plan number has been changed to unique member identifier. The definition remains unchanged; it is a number assigned by BCBSND and listed on the identification card that identifies the subscriber for administrative purposes.

### **Advance Practice Registered Nurse Definition**

The definition of advance practice registered nurse (APRN) has been updated to remove psychiatric nurse; a psychiatric nurse is not considered an APRN.

### **New Phone Numbers**

New phone numbers are being implemented for various departments and can be found on the new identification card.

**City of Fargo**  
**Blue Cross Blue Shield of North Dakota (BCBSND)**  
**Health Insurance Premiums**  
**Effective January 1, 2019**

**Active Employees**  
**BCBSND BlueAccess**

		<b>Employee Pay Period Contribution</b>	<b>COF Pay Period Contribution</b>	<b>Employee Monthly Contribution</b>	<b>COF Monthly Contribution</b>	<b>Combined Monthly Premium</b>	<b>Total Annual Premium</b>
<b>Full-time 40*</b> 2080 annual hrs	Single	\$ 31.41	\$ 192.94	\$ 62.82	\$ 385.88	\$ 448.70	\$ 5,384.40
	Family	\$ 152.01	\$ 390.89	\$ 304.02	\$ 781.78	\$ 1,085.80	\$ 13,029.60

<b>Full-time 30-39*</b> 1560-2017 annual hrs	Single	\$ 76.28	\$ 148.07	\$ 152.56	\$ 296.14	\$ 448.70	\$ 5,384.40
	Family	\$ 249.73	\$ 293.17	\$ 499.46	\$ 586.34	\$ 1,085.80	\$ 13,029.60

<b>Part-time 20-29*</b> 1040-1559 annual hrs	Single	\$ 112.17	\$ 112.18	\$ 224.34	\$ 224.36	\$ 448.70	\$ 5,384.40
	Family	\$ 347.46	\$ 195.44	\$ 694.92	\$ 390.88	\$ 1,085.80	\$ 13,029.60

\*Premiums apply to employees who are benefit eligible as defined in COF policy.

<b>COBRA</b>	
	<b>Monthly</b>
COBRA Single	\$ 457.67
COBRA Family	\$ 1,107.52

**City of Fargo**  
**Blue Cross Blue Shield North Dakota (BCBSND) Dental Premiums**  
**2019**

	Employee Pay Period Contribution	COF Pay Period Contribution	Employee Monthly Contribution	COF Monthly Contribution	Combined Monthly Premium	Total Annual Premium
<b>Full-Time Employee 40 (Scheduled Hours: 40 /week; 2080 /Year)*</b>						
Employee Only	\$0.00	\$20.45	\$0.00	\$40.90	\$40.90	\$490.80
+ spouse	\$20.35	\$20.45	\$40.70	\$40.90	\$81.60	\$979.20
+ children	\$19.35	\$20.45	\$38.70	\$40.90	\$79.60	\$955.20
+ spouse & children	\$40.25	\$20.45	\$80.50	\$40.90	\$121.40	\$1,456.80
<b>Full-Time Employee 30-39 (Scheduled Hours: 30-39/week; 1560-2079/year)*</b>						
Employee Only	\$5.11	\$15.34	\$10.22	\$30.68	\$40.90	\$490.80
+ spouse	\$25.46	\$15.34	\$50.92	\$30.68	\$81.60	\$979.20
+ children	\$24.46	\$15.34	\$48.92	\$30.68	\$79.60	\$955.20
+ spouse & children	\$45.36	\$15.34	\$90.72	\$30.68	\$121.40	\$1,456.80
<b>Part-time Employee 20-29 (Scheduled Hours 20-29/week; 1040 - 1559/year)*</b>						
Employee Only	\$10.22	\$10.23	\$20.44	\$20.46	\$40.90	\$490.80
+ spouse	\$30.57	\$10.23	\$61.14	\$20.46	\$81.60	\$979.20
+ children	\$29.57	\$10.23	\$59.14	\$20.46	\$79.60	\$955.20
+ spouse & children	\$50.47	\$10.23	\$100.94	\$20.46	\$121.40	\$1,456.80

\*Premiums apply to employees who are benefit eligible as defined in COF policy.

**City of Fargo  
Superior Vision Premiums  
2019**

	Employee Pay Period Contribution	Employee Monthly Contribution	Total Annual Premium
<b>All Eligible Employee*</b>			
Employee Only	\$4.93	\$9.86	\$118.32
+ spouse	\$9.32	\$18.64	\$223.68
+ children	\$10.16	\$20.32	\$243.84
+ spouse & children	\$13.17	\$26.34	\$316.08

\*Premiums apply to employees who are benefit eligible as defined in COF policy.



23

## Fargo Inspections

City of Fargo  
224 Fourth Street North  
701-241-1561  
fax 701-241-1526

---

### Memorandum

DATE: October 4, 2018  
TO: Mayor Mahoney and Board of City Commissioners  
FROM: Bruce Taralson, Inspections Administrator *BT*  
SUBJECT: Dangerous Building Notice and Order at 826 10 Street North, Fargo, ND.

---

This is to notify you that the property owner of 826 10 Street N., Fargo, ND, the property that is subject of the attached Notice, has failed to comply with my order to either obtain a permit to repair or remove the heavily damaged structure at that location within the time allowed for that removal. In accordance with Fargo Municipal Code Article 21-0405, it will now be necessary for you to set a date for a hearing of this order at which time the property owner will be able to appear and show cause why the building should not be removed and the costs of that removal assessed against this property.

The recommendation is **to make a motion, in accordance with FMC Article 21-0405, to set November 5, 2018 as the time and date for the hearing regarding the dangerous building order for the structure at 826 10 Street N., Fargo, ND.**



# Fargo Inspections

City of Fargo  
200 Third Street North  
701-241-1561  
701-476-6779 fax



## NOTICE OF DANGEROUS BUILDING

TO: Lee J Allen, DBA ATD Properties, 3508 22<sup>nd</sup> Street S., Fargo, ND 58104-6520

YOU ARE HEREBY Given Notice of the following:

1. That this Notice is being given to you pursuant to Fargo Municipal Code, Article 21-04 concerning Dangerous Buildings.

2. That the building with which this Notice is concerned is commonly known as 826 10 Street North, Fargo, North Dakota, and is located on that tract of land in the city of Fargo, more particularly described as follows:

LOT 10 BLK 10 ADDN# 1140 (Harwoods 3rd)

(hereinafter referred to as "the building")

3. That inspections were made of the building on 6/19/2018 and 7/25/2018 by Bill Thompson, Building Inspector, and on 7/25/2018 by Robert Harshberger, Deputy Assessor, of the City of Fargo.

4. That the building inspector for the City of Fargo has found the building, consisting of a multi-story, wood-framed structure, to be a Dangerous Building within the standards set forth in the Fargo Municipal Code, Article 21-04, Dangerous Buildings and IPMC Code 108.1.5 concerning Dangerous Structures.

5. This building has been found to be a dangerous building by the building inspector. This notice is to remain on this building until it is repaired, vacated, or demolished in accordance with the notice which has been given the owner, occupant, lessee, or mortgagee of this building and all other persons having an interest in said building as shown by the records of the register of deeds of the county of Cass. It is unlawful to remove this notice until such notice is complied with. Source: 1952 Rev. Ord. 21-0404.

6. That the owner of the building must demolish the building within 30 (thirty) days from the date of this notice or obtain a permit to repair. To obtain a permit, see 'Conditions Found Statement' below.

7. That the building is unsafe and is a dangerous building in the following respects: See 'Conditions Found Statement' below.

A. Robert Harshberger, Deputy Assessor, of the City of Fargo has deemed that the building has been damaged or deteriorated to the extent of more than fifty (50) percent of its original value prior to the damage or deterioration. Source: Fargo Municipal Code, Article 21-0402 concerning Dangerous Buildings.

8. The building is unsafe and constitutes a public nuisance pursuant to Fargo Municipal Code, Article 21-04 concerning Dangerous Buildings and Section 116 of the International Building Code as adopted by Article 21-0101 of the Fargo Municipal Code.

9. You are further given Notice that unless the building is demolished within the time period set forth herein, the City of Fargo will take such steps as are necessary to cause said building to be demolished pursuant to Fargo Municipal Code, Article 21-04 concerning Dangerous Buildings and the International Building Code and the owner will be assessed such costs as are provided for therein.

10. Order for vacation of building. The undersigned building official has determined that the building or structure must be vacated as required by Section 108.2 of the International Property Maintenance Code, 2015 edition. Therefore, it is hereby ordered that the building or structure shall be vacated immediately, and remain vacated, on this 20<sup>th</sup> day of August, 2018.

11. Order to secure building. The undersigned building official has determined that the building must remain secured. Therefore, it is hereby ordered that all means of entering the building remain secured to prevent unauthorized entrance. **An inspector will continue to verify compliance.** Failure to keep the building secured will result in the City of Fargo hiring an independent contractor to secure the building. All expenses for securing the building will be assessed against the property.

12. This Dangerous Building Notice takes precedence over previous notices regarding this building.

Dated this 20<sup>th</sup> day of August, 2018.



---

Bruce Taralson  
Inspections Administrator

Conditions Found Statement

On 6/19/2018 and 7/25/2018, inspector, Bill Thompson, was present at 826 10 Street N., Fargo, ND 58102 for a complaint inspection. The following violations were found:

- Building is structurally unsound.
- Structure is infested with pigeons.
- Extensive water damage.
- North foundation wall has buckled.

The following actions must be taken:

- Provide engineering on structure, mechanical, plumbing and electrical systems.
- Provide structural plans.
- Provide list of licensed trades with plans.
- Obtain a new permit and follow through with all necessary inspections.

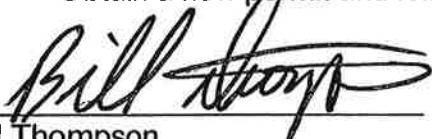

Bill Thompson  
Building Inspector  
City of Fargo, ND

8-20-18

Date Signed

24

October 8, 2018

To: City Commission

From: Tim Dirks, MLIS, MPA *TD*  
Director  
Fargo Public Library

The Fargo Public Library continues to strive to provide engaging and important programming to benefit the community. We are partnering with the Plains Art Museum to provide the *Bring Her Home* exhibit at the Main Library. In conjunction with the City Attorney's Office and the Plains Art Museum a draft agreement has been identified.

**Recommended motion:**

To approve the fine arts loan agreement with the Plains Art Museum to allow for the showing of the *Bring Her Home* exhibit at the Main Library.

**Attachments:**

Fine Arts Loan Agreement for the *Bring Her Home* exhibit.

**AGREEMENT**

**This agreement** (hereinafter “Agreement”), is made and entered into this \_\_\_\_\_ day of \_\_\_\_\_, 2018, by and between the **City of Fargo**, a North Dakota municipal corporation (hereinafter “City”), and the **Plains Art Museum**, a North Dakota Nonprofit Corporation (hereinafter “Plains Art”).

**WHEREAS**, Plains Art wishes to loan specific pieces of artwork (hereinafter “Artwork”) to the City for the “Bring Her Home” Exhibit (hereinafter “Exhibit”); and,

**WHEREAS**, Plains Art is the owner or authorized possessor of the Artwork being loaned with the authority to execute this Agreement; and,

**WHEREAS**, the Exhibit will be on display from \_\_\_\_\_, 2018 through \_\_\_\_\_, 2018 in the concourse gallery space of the Fargo Public Library (hereinafter “Exhibit Location”); and,

**WHEREAS**, the parties wish to set forth the terms of their agreement in writing; and,

**NOW, THEREFOR**, in consideration of the mutual covenants and agreements contained herein, the parties agree as follows:

1. Purpose of the Agreement. Plains Art will loan twenty-three (23) pieces of Artwork described in **Attachment A**, which is attached hereto and incorporated by this reference (collectively, the “Artwork”) to City, subject to the terms and conditions below.
2. Exhibiting Location. City will exhibit the Artwork in the concourse gallery space of the Fargo Public Library, located at 102 3<sup>rd</sup> Street North, Fargo, North Dakota 58102. The gallery space is generally open to the public during regular library hours.
3. Term of Agreement. The term of this Agreement shall be from \_\_\_\_\_, 2018 to \_\_\_\_\_, 2018.
4. Receipt, Installation, and Removal of the Artwork. Plains Art agrees to deliver the Artwork to the Exhibit Location on \_\_\_\_\_, 2018. Artwork will be delivered and installed \_\_\_\_\_, 2018 by Plains Art’s staff. Artwork will be removed on \_\_\_\_\_, 2018 by the Plains Art’s staff. The description of the condition check upon arrival and departure is incorporated in **Attachment B**.
5. Active Use of Library. The Exhibiting Location is an active library that is open to the public. Plains Art agrees to accept full responsibility for any loss or damage that occurs to the Artwork while it is located in the Exhibiting Location. Artwork shall be delivered by Plains Art in good condition, unless otherwise noted by Plains Art. No Artwork will be

exhibited which might be deemed unsafe or cause damage to the Exhibiting Location, which condition may be assessed by the Library's staff. City agrees that Artwork shall not be removed during the exhibition period.

6. Insurance. City will not provide insurance for the Artwork and shall bear no responsibility for any damage, claims, demands, theft, defacing, fire, water, tearing, cracks, breakage, dents or other types of damage to the Artwork at any time. Plains Art will supply insurance at its sole expense. Artwork shall be insured during the period of this loan for the value stated in this Agreement. The declared value of all Artwork totals \$20,195.00. The declared value represents the current market value at the time the Artwork is insured for the Exhibit.

7. Ownership. Plains Art hereby warrants that it is the owner or authorized possessor of the Artwork being loaned with the authority to execute this Agreement.

8. Copyright. The copyright of the Artwork shall remain with the Artist.

9. Credit. Plains Art (and the Artist if the Artist is represented by a gallery) will be credited whenever any work is exhibited in public or an image of the work is published by or for the Fargo Public Library, provided that Plains Art will supply Library with the appropriate attribution for such credit.

10. Applicable Law. This Agreement will be construed and enforced in accordance with North Dakota law. The parties agree any litigation arising out of this Agreement will be venued in District Court in Cass County, North Dakota, and the parties waive any objection to personal jurisdiction.

11. Waiver. The failure or delay of City to insist on the performance of any of the terms of this Agreement, or the waiver of any breach of any of the terms of this Agreement, will not be construed as a waiver of those terms, and those terms will continue and remain in full force and effect as if no forbearance or waiver had occurred and will not affect the validity of this Agreement, or the right of the City to enforce each and every term of this Agreement.

12. Severability. If any court of competent jurisdiction finds any provision or part of this Agreement is invalid, illegal, or unenforceable, that portion will be deemed severed from this Agreement, and all remaining terms and provisions of this Agreement will remain binding and enforceable, and the parties' obligations under this Agreement will remain binding and enforceable.

Fine Arts Loan Agreement  
Exhibit: Bring Her Home

13. Indemnification and Release. Plains Art agrees to indemnify, defend, and hold the City harmless from any liability (including attorney’s fees and the costs of defending any actions) arising out of any claim by any individual, institution, or other person claiming full or partial title or copyright to the Artwork. Plains Art accepts all risk associated with the Artwork being on display and hereby releases all claims, including subrogated claims, against City for any loss or damage to the Artwork, however caused.

14. Entire Agreement. This Agreement, together with any related documents, as well as any amendments to those agreements and documents, constitutes the entire agreement between the parties regarding the matters described in this Agreement.

15. Modifications. Any modifications or amendments of this Agreement must be in writing and signed by both parties to this Agreement.

This Agreement is entered into as of the day and year first written above.

CITY OF FARGO, NORTH DAKOTA,  
a municipal corporation

By \_\_\_\_\_  
Timothy J. Mahoney, M.D., Mayor

ATTEST:

By \_\_\_\_\_  
Steve Sprague, City Auditor

PLAINS ART MUSEUM

By \_\_\_\_\_  
Steve Jacobs  
Registrar and Building Operations Manager

**ATTACHMENT A**

Exhibition Title: Bring Her Home

Total Artworks Loaned: 23

Loan Period: \_\_\_\_\_, 2018 – \_\_\_\_\_, 2018

Artwork Description Contents: Artist, Title, Dimensions, Medium Current Market (if available). Artwork considered “good” unless duly noted.

*Any issue with condition(s) of the Artwork upon arrival to Fargo Public Library has been noted in the right column.*



Kali Spitzer

(w x h x d) 32 1/4” x 40 1/4” x 3/4”

Melaw Nakehk’o, 2016

Archival Pigment Print

NWICDC - replaced cardboard with foam core.

Exploration of Resilience  
 (ongoing project)

An Exploration of Resilience is about identity, culture, strength, vulnerability, and love – these images are about resilience. This work investigates different facets of people and how they explore themselves. In this series, I am photographing my community of mostly Indigenous and mixed heritage people, while challenging preconceived notions of race, gender and sexuality to touch on how we can become more empathic, empowered people despite the hardships that we have endured. Every photograph, every person, has a story to tell, and I am telling it through their portrait. I hope the viewer can recognize the different sides of these stories, including the pain, but most of





all, the subject's spirit and perseverance.

MMIW is nothing new in Canada and across the world. To dominate land, one must dominate the Original Mothers and Daughters of the territory. The Canadian legacy of colonization, residential schools and intergenerational trauma has led to an epidemic of MMIW. In Canada alone, there are an estimated 4,000 Indigenous women missing or murdered. Yet, the general public remains unaware and/or resistant to seeking justice and accountability.

So often our mothers, daughters, sisters and aunties are not afforded voice or visibility. Indigenous women are viewed as less than, even dehumanized by some. This Lends to people's predisposition to commit violence against us. It is racism and cold hearts that enable others not to see Indigenous women and girls of the land as equal and invaluable – rather as "something" that can be thrown away and abused. Yet, resiliency is an inherent right of Indigenous Peoples and territories. It is this interrelationship that also enables our mutual healing. For this reason, I stress the importance of supporting one another, holding each other up and keeping each other safe, defending one another's path of restoring self and homelands.

In order to heal we must be seen and heard.

	<p>By showing these raw, vulnerable images of the powerful women you see here today I strive to initiate the conversations of our truths and the starting of our healing. In order to heal we must be seen and heard.</p> <p>In an era of settler colonization, it is my hope to have you, the viewer, see the stories and portraits that I present as a celebration of Indigenous women and our strength, our connection to mother earth and most of all our empowerment and resilience.</p>	
	<p>Kali Spitzer</p> <p>Shaggy, 2016          Archival Pigment Print</p>	<p>(w x h x d) 32 1/4" x 40 1/4" x 3/4"</p> <p>NWICDC - Arrived with picture dropped in frame, mat slightly warped at top. Took to framing to fix. Backed with cardboard and was recommended to replace with foam core, so replaced.</p>
	<p>Kali Spitzer</p> <p>Sasha Lapointe, 2016          Archival Pigment Print</p>	<p>(w x h x d) 32 1/4" x 40 1/4" x 3/4"</p>

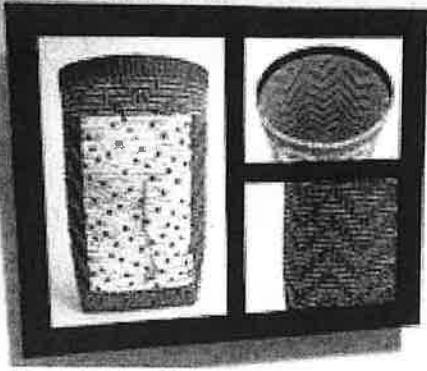

Shan Goshorn

This River Runs Red, 2018  
Approx 8" X 8" X 12"

Arches watercolor paper  
splints printed with archival  
inks, acrylic paint, artificial  
sinew

Traditionally, native women held positions highly revered in their communities, often respected as leaders, warriors and always as the bringers of life. However, after first contact, non-native men frequently viewed indigenous women as disposable sexual commodities. Based on today's disproportionately higher rate of violence toward native women and a judicial reluctance to prosecute these crimes, it is a belief that appears to be ongoing.

Statistics in the U.S. indicate three in five native women will be physically assaulted; 34% will be raped; on some reservations, native women are murdered at more than ten times the national average; and U.S. attorneys declined to prosecute 67% of sexual abuse related cases. In Canada, a 2015 report by the Royal Canadian Mounted Police (RMCP) concluded 1,049 aboriginal women had been slain between 1980 and 2015, and that another 175 were considered missing. Patty Hajdu, Canadian Minister for the Status of Women, reported



The basket was sold. The piece is represented in the exhibit with a photograph.



20" x 16" x 1 1/2" metal print

NWICDC - This piece is the property of Northwest Indian Community Development Center and will need to be returned at end of exhibition period.

	<p>in 2017 that 4,000 would be a more realistic number based on a history of police under-reporting or failure to properly investigate cases. The Canadian Broadcasting Corporation (CBC) reports that activists with the Walk 4 Justice initiative collected at least 4,232 names of missing or murdered indigenous women.</p> <p>Although the numbers tell a story, revealing a tragic disparity that must be rectified, we must remember the persons behind the numbers. This Cherokee style single-weave basket was created not only to point to the statistics but also to humanize women who've lost their lives. Woven in the traditional pattern called "Water", the vertical splints are printed with high stats of violence directed at native women in the U.S.; the horizontal splints compile the discrepancy in gathering such numbers in Canada. The interior is printed with the names and tribes, compiled by the CBC, of 306 murdered and missing women, cases the RCMP dismissed as solved. The families of these women dispute this resolution.</p> <p>The Red River, which runs from Winnipeg, Canada to northern South Dakota, has become known as a place where the bodies of women are regularly recovered making its name (Red River)</p>	
--	--	--

	<p>heartbreakingly fitting. Included on the front of the basket is a red-lined map of this river, a visual gash to serve as a reminder of this place where native women have been discarded and seemingly forgotten. It is time to recognize the humanity of these women, mourn the value of their lives and put a stop to this terror.</p>	
	<p>Luzene Hill                  Missing..., 2018                  Beeswax, Silk, Cochineal</p> <p>Missing. . .</p> <p>prolonged, ongoing loss - without surety or closure</p> <p>The phenomenon of missing and murdered Native women is a symptom. The illness is American colonialism - resulting in an invisible population, on the political periphery in this country. Colonialism spawned disruption of indigenous societies . . . disruption of the body, the community the culture</p> <p>Domination is the defining message that envelopes violence against women. A woman is dominated and she is made to feel powerless.</p> <p>394 yards of cochineal dyed silk, 25 inches (the length of my arm) for each federally recognized tribe in the US.</p>	<p>Stand needed for installation. Figure is approximately 5" x 6" x 5" (w x h x d)</p> <p>Figure arrived in plastic container, loosely floating, made sure to pack more securely before sending to Gizhiigin. Silk is in cardboard box.</p> <p>Artist has provided samples of various ways to display. I can forward this information as needed.</p> <p><b><i>This piece, "Missing...", WILL NOT be on display at the Fargo Public library.</i></b></p>

	<p>Additional strips added during the exhibition will begin a reckoning for the unknown numbers of missing and murdered Native women.</p>	
	<p>Hillary Kempenich</p> <p>Prayers Up, Tobacco Down, 2018</p> <p>Acrylic on Canvas</p>	<p>38 ¼" x 14 ½" x 2 ½"</p> <p>NWICDC - Will need to inquire with purchaser if this will continue to travel.</p> <p>Packed in plastic only.</p>
	<p>Hillary Kempenich</p> <p>Dear Savannah, 2017</p> <p>Acrylic on Wood</p>	<p>13" x 16" 2 ½"</p>

	<p>Hillary Kempenich          Nimiikaage (She Dances For the People), 2017          Mixed Media</p>	<p>Sold will not travel after Gizhiigin exhibit</p> <p>NWICDC - Artwork packed, with other mixed media piece. Shadow box wrapped in heavy plastic only.</p>
	<p>Hillary Kempenich          Youthful Prayers, 2018          Mixed Media</p>	<p>Sold will not travel after Gizhiigin exhibit</p> <p>Artwork packed with other mixed media piece. Shadow box packed in plastic only.</p>



Kayeri Akweks

Did You Forget?, 2017

Drawing with Graphite, Ink, Watercolor, Prismacolor

This is what one healthy, happy, joyful, thoughtful, sweet and kind, innocent, non-sexualized Indigenous female looks like, in case you forgot. You can stare at this image anytime you forget that birthright, and you are trying to remember.

27 3/4" x 35 3/4" x 1"

Arrived at Gizhiigin with red pigment dust stains on the mat

NWICDC  
 Red pigment dust on mat - note this was also present at AMRA.



Keith Secola

Wounds Many, 2018

Screen print on book covers

The work I make encompasses both historical and contemporary aspects of Native American life gathered from the culture and traditions of my Northern Ute and Anishinaabe backgrounds. I utilize historic family photographs to represent lost information and histories in America. "Wounds Many" was a photo from my grandmother's album in the early years on the Uintah & Ouray Indian Reservation.

25 3/4" x 33 3/4" x 1/4"





Lucas Reynolds  
 Murdered and Missing  
 Indigenous Girl, 2017  
 Photo Illustration Print on  
 Metal

24" x 16" x 1/2"  
 NWICDC - Packed with  
 James Autio's work.





James D. Autio  
 Out There, 2017  
 Ink and Gesso on Paper

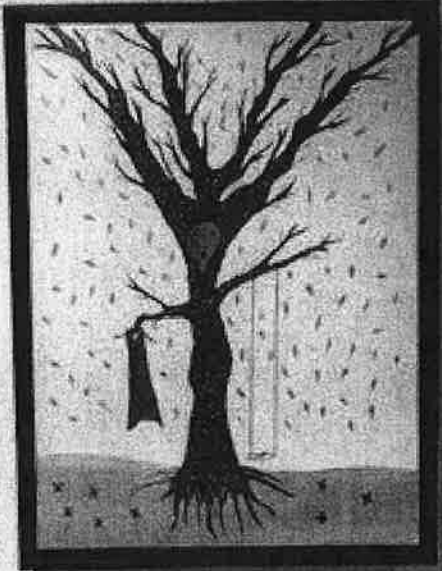

21 1/4" x 15" x 3/4"  
 NWICDC - Packed with  
 Lucas Reynold's work, was  
 wrapped in a small fabric  
 quilt.

While the search for Olivia Lone Bear is ongoing, I created a few different artworks to honor Lone Bear and her family. I hope to help raise consciousness of the horrible reality of Missing and Murdered Indigenous Women in the lives of so many people. Out There for me captures a bit of the desperate isolation and vast uncertainty of searching for a lost loved one. This drawing is based on an original shot of me walking the tracks at Grassy Point, taken by my sister, photographer, Bette Autio

The Fabric quilt belongs to the artist and needs to be returned to the artist after the show is done traveling.

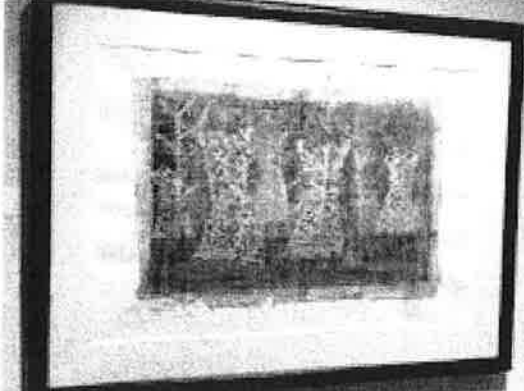
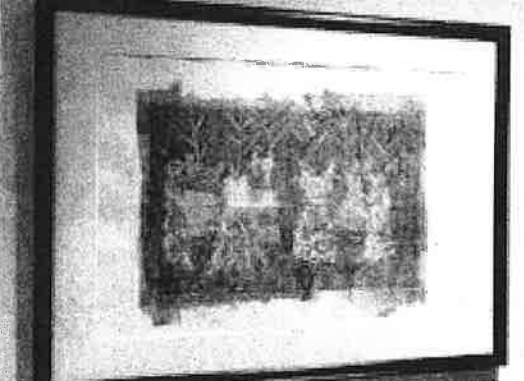
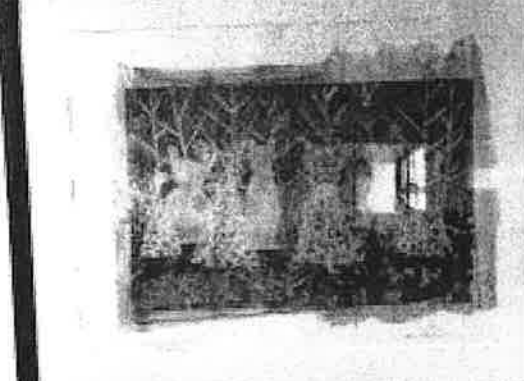
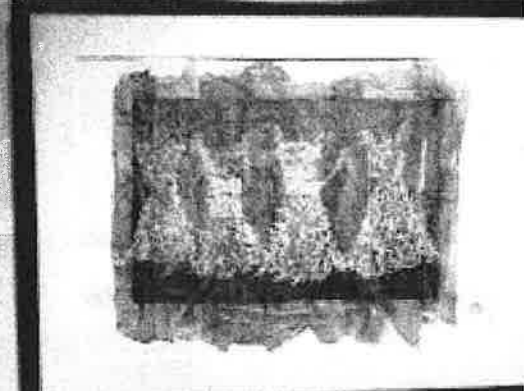
	<p>Paula Littlewolf</p> <p>Bring Her Back, 2017</p> <p>Acrylic on Canvas</p> <p>The tree has known this woman since childhood. She has swung in her branches. Now she is left with a red dress. She has withered and aged and lost all of her leaves waiting for someone to Bring Her Back.</p>	<p>19 1/2" x 25 1/2" x 1 1/4"</p>
	<p>Dawn Dark Mountain &amp; Karen Ann Hoffman</p> <p>Never Alone, 2013</p> <p>Sculptural Watercolor (by Dawn Dark Mountain) with Iroquois Raised Beadwork (by Karen Ann Hoffman)</p>	<p>31 1/4" x 39 1/4" x 1 1/2"</p>

	<p>Laura Youngbird</p> <p>More Than a Memory 1, 2018</p> <p>Mixed Media</p>	<p>33 3/4" 25 3/4" x 1"</p> <p>Condition on delivery to Gizhiigin: Frame has a 5 1/2 inch long chip on the left side toward the back edge 8 inches from the top.</p> <p>NWICDC - Replaced back paper, which was torn.</p>
	<p>Laura Youngbird</p> <p>More Than a Memory 2, 2018</p> <p>Mixed Media</p>	<p>33 3/4" 25 3/4" x 1"</p>
	<p>Laura Youngbird</p> <p>More Than a Memory 3, 2018</p> <p>Mixed Media</p>	<p>33 3/4" 25 3/4" x 1"</p>
	<p>Laura Youngbird</p> <p>More Than a Memory 4, 2018</p> <p>Mixed Media</p>	<p>33 3/4" 25 3/4" x 1"</p> <p>Condition on delivery to Gizhiigin: Frame has 2 chips - - one is 3/4" and the other is 5 1/2 inch long -- on the top side toward the back edge.</p>

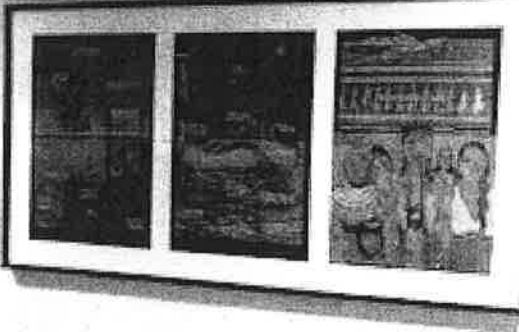
		NWICDC - Frame with minor damage in back. Not visible when displayed.
	<p>Tamara Aupaumut</p> <p>She is with the Moon, 2017</p> <p>Acrylic on Linen</p>	<p>19 1/2" x 23 1/2" x 1"</p>
	<p>Cara Romero</p> <p>Bring Her Home, 2018</p> <p>Archival Pigment Print on Metallic Paper, Mounted Under Acrylic</p>	<p>24" x 18" 1 1/4"</p>
	<p>Weshoyot Alvitre</p> <p>To Dress in Red, 2017</p> <p>Archival inkjet print</p> <p>This piece was created for a graphic novel entitled, Deer Woman: An Anthology from Native Realities Press. It</p>	<p>59" x 31 1/2" x 1 1/2"</p> <p>NWICDC - Arrived wrapped in heavy plastic thin foam pad on front.</p>

addresses issues Native women experience through the common thread of the stories of Deer woman within their tribal narratives. The 3-piece story is a tribute to Missing Murdered Indigenous Women. As a woman and mother, I tried to encompass all aspects of how the issue of MMIW affect women, their families and the space around them.



Leah Kolakowski  
  
Dezbah, 2018  
  
Photograph

27" x 27" x 1"  
  
Condition on delivery to Gizhiigin: shallow scratches/abrasions on the lower right side face of the frame  
  
NWICDC - Scratches on front right side of frame not highly visible. Should be able to fill with scratch crayon.

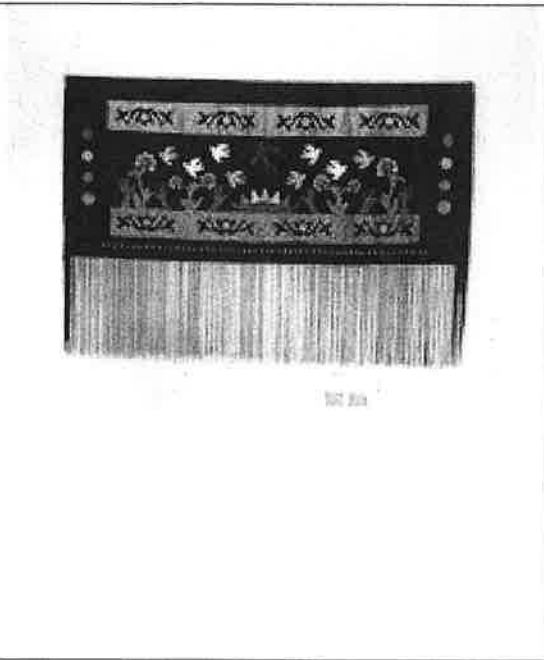

Chholing Taha  
  
Lost Birds Return, 2018  
  
Wool, Silk, Ultrasuede, Swarovski Crystals  
  
The imagery on applique symbolizes the community (red hands) welcoming the lost Sisters (white and blue birds) home. In the center is the Winter Solstice Sun (coming out of darkness) with the Thunderbird Bird soaring upward (overcoming adversity)

64" x 46" x 1/2"  
  
Adjustable pole included for hanging  
  
NWICDC - Misplaced hanging racks for pole that screw into wall. Will replace.

	<p>Lori Greene</p> <p>The Escape, 2018 Glass and Ceramic Mosaic</p> <p>When I saw the lake and its overwhelming beauty – I knew I had/would survive. The trees were both my saviors and a curse, densely packed, their branches were tangled in my hair. I used my hands to push the branches from my covered face. My eyes were blind folded with a hat pulled over my face and I slowly worked the hat up so I could see. He could not see this because he and the rifle were far behind.</p>	<p>39” x 24” x 3/4”</p> <p>Condition on delivery to Gizhiigin: small chip on the other edge left side top corner.</p> <p>NWICDC- Small chip out of backing on top left side. Not visible in front</p>
	<p>Ginger Dunnill</p> <p>Forgiveness Poem, 2017 Audio Recording</p>	<p>Mp4 file</p> <p>Companion piece to Kali Spitzer photos</p>

**ATTACHMENT B**

Total Artworks Loaned: 23

Date of Installation: \_\_\_\_\_, 2018

Total Value of Artworks: \$20,195.00

Name of Person(s) Completing Condition Check Upon Arrival and Departure:

\_\_\_\_\_  
\_\_\_\_\_  
\_\_\_\_\_  
\_\_\_\_\_

**Date of Delivery:** \_\_\_\_\_, 2018

Plains Art Initial: \_\_\_\_\_

Library Initial: \_\_\_\_\_

**Date of Return:** \_\_\_\_\_, 2018

Plains Art Initial: \_\_\_\_\_

Library Initial: \_\_\_\_\_



PUBLIC WORKS/OPERATIONS

Fleet Management, Forestry, Streets & Sewers, Watermeters, Watermains & Hydrants 402 23rd STREET NORTH FARGO, NORTH DAKOTA 58102 PHONE: (701) 241-1453 FAX: (701) 241-8100

25

September 26, 2018

The Honorable Board of City Commissioners City of Fargo 225 4th Street North Fargo, ND 58102

RE: 2018 4 Ton Hot Patcher (PBCSM1647C)

Commissioners:

A cost evaluation process was started in September for the purchase of a new 4 Ton Hot Patcher Asphalt trailer. North Dakota and Minnesota State bids along with H-GAC were researched and evaluated. It was determined that utilizing a purchasing consortium was the best solution for the purchase. The Houston/Galveston Area Co-op (HGAC) has contract number SM10-16 (Street Maintenance Equipment) available that meets all of the City of Fargo purchasing guidelines.

The review committee, consisting of Allan Erickson and Tanner Smedshammer, determined which proposals met the specifications required. A proposal synopsis is attached for your clarification and consideration. It is our recommendation to purchase from Spaulding Mfg. Inc. using the HGAC Buying contract. Funding for this project is included in the 2018 Vehicle Replacement Budget.

SUGGESTED MOTION:

Approve the recommendation to purchase one (1) Spaulding 4 Ton Hot Patcher thru HGACBuy for the total amount of \$52,556.00.

Respectfully Submitted,

[Handwritten signature of Tanner Smedshammer]

Tanner Smedshammer Fleet Management Specialist







**CONTRACT PRICING WORKSHEET**  
For Standard Equipment Purchases

Contract No.:

SM10-16

Date Prepared:

9-25-2018 R1

**This Worksheet is prepared by Contractor and given to End User. If a PO is issued, both documents MUST be faxed to H-GAC @ 713-993-4548. Therefore please type or print legibly.**

Buying Agency:	City of Fargo ND / NTS	Contractor:	Spaulding Mfg Inc
Contact Person:	Tanner Smedshammer/ Wade NTS	Prepared By:	Linda Kwapis
Phone:		Phone:	
Fax:		Fax:	
Email:		Email:	

Product Code:	47CD1	Description:	4 Ton Hot Patcher
---------------	-------	--------------	-------------------

**A. Product Item Base Unit Price Per Contractor's H-GAC Contract:** 20550

**B. Published Options - Itemize below - Attach additional sheet if necessary - Include Option Code in description if applicable**  
(Note: Published Options are options which were submitted and priced in Contractor's bid.)

Description	Cost	Description	Cost
spat-PROPANE burner	780	sphdht- hydraulic dump with powr up /power down	4650
spajhcho-oil jacket hopper	4750	slssl-2 Amber Strobe Lights	840
sppchl- rear mount hydraulic tamper lift	2850	sphtd- top hydraulic doors -	1600
sp30htt-30 Gallon Tack Tank	2750	arledsl-Arrow Stick Directional Light	1135
sphesvp- spray system with honda engine and asphalt pump	2950	29 inch hitch extension/ 5/8 d rings w/ double clevis 3/8 tow	std
Battery Charger std on dump	0	chain/ 235/80/16 tires /7000 tandem axles/	std
sp12gst- Solvent Tank for Shovels	280	frame 6x2x 5/16 wall/auto temp control	std
sp5pcth-5 Piece Tool Holder	157	spttl- spare tire	280
sphrds- rear hydraulic single door with safety override	1180	sp110volt-120v electric overnight heat	2141
sptrhr- hose reel with 30 ft hose and wand dead man style	690		
		<b>Subtotal From Additional Sheet(s):</b>	
		<b>Subtotal B:</b>	27033

**C. Unpublished Options - Itemize below - Attach additional sheet if necessary**  
(Note: Unpublished options are items which were not submitted and priced in Contractor's bid.)

Description	Cost	Description	Cost
		<b>Subtotal From Additional Sheet(s):</b>	
		<b>Subtotal C:</b>	0

**Check:** Total cost of Unpublished Options (C) cannot exceed 25% of the total of the Base Unit Price plus Published Options (A+B). **For this transaction the percentage is:** 0%

**D. Total Cost before any other applicable Charges, Trade-Ins, Allowances, Discounts, Etc. (A+B+C)**

Quantity Ordered:	1	X Subtotal of A + B + C:	47583	=	Subtotal D:	47583
-------------------	---	--------------------------	-------	---	-------------	-------

**E. Trade-Ins / Special Discounts / Other Allowances / Freight / Installation / Miscellaneous Charges**

Description	Cost	Description	Cost
		FOB SAGINAW	
4% steel charge	1973		3000
		<b>Subtotal E:</b>	4973

**Delivery Date:** 90 Days ARO **F. Total Purchase Price (D+E):** 52556

Price quote for:	<b>Pothole Patch/Recycler</b>			
Vendor:	ABM EQUIPMENT & SUPPLY, LLC.			
Model:	SPAULDING MFG			
Spec #	Description	Qty	Price	Subtotal
1.0	<b>Price for Pothole Patch/Recycler Base Unit:</b>	1	\$ 17,950.00	\$ 17,950.00

2.0	<b>Hopper Options:</b>			
2.1	3 ton hopper capacity includes 7,000 LB tandem axles 14,000 GVWR,235/80/R16E tires, empty weight 3000 LBS		\$ 3,270.00	\$ -
2.2	4 ton hopper capacity includes 7,000 LB tandem axles, 14,000 GVWR,235/80/R16E tires,empty weight 4300 LBS	1	\$ 4,270.00	\$ 4,270.00
2.3	6 ton hopper capacity includes scissor hoist and 10,000 Lb oil bath hub axles 20,000 GVWR,LT235/75R/17.5H tires, frame 2x8x3/8 and hydraulic bi-fold top doors and rear hydraulic door, self contained 12dcv power hydraulic system, empty weight 5000LBS, 12,000 LB screw jack, 2 diesel burner standard both bottom mounted.		\$ 29,970.00	\$ -
2.4	Some options add length to trailer, upgrade to frame in layout drawings for customer review, 1 foot of upgrade to frame, priced by the foot any length over 18 ft will be reviewed and possible subject to this upgrade		\$ 110.00	\$ -
2.5	Slip- in hopper with 4 top lifting eyes, d rings for tie down and rear cross bar for latching		\$ (700.00)	\$ -
2.6	Hook lift skid		\$ 4,500.00	\$ -
2.7	Catwalk for Pothole patch units must meet OSHA 29CFR-1910, Subpart D		\$ 920.00	\$ -
2.8	Auger unloading with diesel engine power		\$ 18,900.00	\$ -

3.0	<b>Burner/Heater Options:</b>			
3.1	Diesel fuel pre-heater, water seperator on filter included		\$ 480.00	\$ -
3.2	Electric overnight heat 110VAC for maintaing asphalt at tempeature between 170F-190F includes 2 electric overnight heat 750 watt elements for a 1500 watt total 20 AMP service.A rear mounted Nema 4 control box has an 1/2" red indicator light and will not allow 12vdc burners to operate while plugged in to shore power. Same digital controller operates heat setting up to 190F for maintainng asphalt in hopper. System is ground fault protected with test button and reset button on system and red safety stop button to disconnect service at trailer.	1	\$ 2,350.00	\$ 2,350.00
3.3	Electric overnight heat 220VAC for maintaing asphalt at tempeature between 170F-190F includes 2 electric overnight heat 750 watt elements for a 1500 watt total 40 AMP service. A rear mounted Nema 4 control box has an 1/2" red indicator light and will not allow 12vdc burners to operate while plugged in to shore power. Same digital controller operates heat setting up to 190F for maintainng asphalt in hopper. System is ground fault protected with test button and reset button on system and red safety stop button to disconnect service at trailer.		\$ 2,650.00	\$ -
3.4	Battery charger 15 Amp Marine sealed 110VAC for overnight charging. LED smart technology shuts down when 100% charged and will not discharge battery.	1	\$ 430.00	\$ 430.00
3.5	7 day 24 hour sealed timer in Nema 4 control box, includes digital real time clock.	1	\$ 750.00	\$ 750.00
3.6	Hour Meter 10,000 hours mounted in Nema 4 control box	1	\$ 120.00	\$ 120.00
3.7	Volt meter for visual battery maintenance mounted in Nema 4 control box		\$ 120.00	\$ -
3.8	Digial Diagnostic readout system for diesel burner, includes an additional audible alarm and indicator light when burner opertion fails.Mounted in Nema 4 control box.			\$ -
3.9	Dual burner recycling Package for either fuel service, includes additional top burner, and hopper ductwork on air jacketed RMV style hoppers only.		\$ 4,600.00	\$ -

3.10	Oil Jacketed hopper includes 9/16 floor with full metal jacket on floor and all 4- 10 gauge steel walls top to bottom, 3 " center divider in hopper allows hot oil to move from bottom to top , throught center of hopper and side to side and front to rear. Oil temperatures are even from bottom to top. Front mounted overflow tank , rear drain, front dip stick and fill port.	1	\$ 4,600.00	\$ 4,600.00
------	--	---	-------------	-------------

<b>4.0</b>	<b>Torch/Sprayer Options:</b>			
4.1	LP hand torch- includes torch holder for torch and 20LB (empty for shipping) propane tank, regulator and pressure gauge, 30 ft of LP hose on bracket		\$ 730.00	\$ -
4.2	Wash down spray system includes 10 gallon tank with magnetic drain and top 2 inch vented fill port, 30 foot hose with bracket , spray wand, 12VDC pump mounted in Nema 4 box with toggle switch. For use in cleaning and spraying release agents.		\$ 870.00	\$ -
4.3	Hand Held 2 gallon metal hand pump sprayer with brass wand, and mounted in metal holder on rear of trailer.		\$ 270.00	\$ -
4.4	Spray system for tack or reclimate includes gravity feed as well as spray system with Honda engine 3.5 HP and a 6:1 gear reduction cuopled to a heavy duty asphalt pump with built in relief on the pump. A hard line piping system allows pulling material off the bottom of the tank and reblending it in the tank for revived suspension. A single valve directs the material to the spray wand with a dead man handle for safety. a 8 gallon solvent tank is provided to flush lines and pump.	1	\$ 2,950.00	\$ 2,950.00

<b>5.0</b>	<b>Hose Reel Options:</b>			
5.1	Hose Reel for LP torch		\$ 700.00	\$ -
5.2	Hose Reel for washdown system	1	\$ 690.00	\$ 690.00
5.3	Hose reel for tack or reclimate	1	\$ 850.00	\$ 850.00

<b>6.0</b>	<b>Tank Options:</b>			
6.1	30 gallon Heated , air jacketed insulated tack tank or reclimate tank with automatic temperture controls up to 120F and stand alone separate controlled burner (fuel system of LP or Diesel), 8 inch fill port, gravity discharge		\$ 2,750.00	\$ -
6.2	30 gallon Heated , oil jacketed insulated tack tank with automatic temperture controls up to 350F and stand alone separate controlled burner (fuel system of LP or Diesel), 8 inch fill port, gravity discharge	1	\$ 2,950.00	\$ 2,950.00

<b>7.0</b>	<b>Trailer Options:</b>			
7.1	Hydraulic surge actuator with steel lines to all hydraulic hubs on axles, safety brake away, single axle		\$ 1,290.00	\$ -
7.2	Hydraulic surge actuator with steel lines to all hydraulic hubs on axles, safety brake away, tandem axle	1	\$ 1,500.00	\$ 1,500.00
7.3	Spare tire and rim mounted on or under trailer frame 235/80R/16E		\$ 385.00	\$ -
7.4	Spare tire and rim shipped loose 235/80R/16E		\$ 280.00	\$ -

<b>8.0</b>	<b>Cab &amp; Chassis Options: NA</b>			
------------	--------------------------------------	--	--	--

<b>9.0</b>	<b>Lighting Options:</b>			
9.1	LED Strobes 5" tall top door mounted and self leveling on dump trailer		\$ 528.00	\$ -
9.2	LED arrow directional stick with 6 functions self leveling on dump trailer, controller mounted in a separate Nema 4 control box curbside at bracket.	1	\$ 1,135.00	\$ 1,135.00
9.3	Dual rear mounted LED 1100 LUMENS each spot night work lights adjustable, toggle switch operation.		\$ 700.00	\$ -
9.4	Mini strobes set of 4 ( 2 rear mounted below sight vision of opeators and 2 midship with eyebrow protection) toggle switch, mounted in rear control box		\$ 700.00	\$ -

10.0	<b>Arrow Board Options:</b>			
10.1	LED arrowstick mounted in front of hopper	1	\$ 1,135.00	\$ 1,135.00
11.0	<b>Other Options:</b>			
11.1	Dump trailer for hopper, ( price includes tandem axle, audible alarm when any hydraulic function occurs to warn operators of movement,upgrade to 8D battery mounted in lockable vented front control box,self contained hydraulic tank, 12vdc motor, manifold with cartridge valves and coils with fuse protection ,pendents for each function in metal holster , 50 amp hydraulic safety master switch, 4 gauge wires and battery terminal connections color coded.soft lines to bulk head and entire sytem hard lines to grease zerk fittings on 2-hydraulic cylinders for lifting hopper.	1	\$ 4,700.00	\$ 4,700.00
11.2	Hydraulic top doors	1	\$ 1,600.00	\$ 1,600.00
11.3	Hydraulic rear single door	1	\$ 1,180.00	\$ 1,180.00
11.4	Hydraulic rear dual doors		\$ 2,030.00	\$ -
11.5	Hydraulic tamper lift(tamper not included)	1	\$ 2,350.00	\$ 2,350.00
11.6	Hydraulic Bulldog roller lift (Bulldog roller not included)		\$ 2,250.00	\$ -
11.7	Bulldog Vibratory roller, compacts at 850PSI, weighs 100LBS, water tank and scraper bars		\$ 2,850.00	\$ -
11.8	Basket holder for Bulldog roller		\$ 250.00	\$ -
11.9	10 LB fire extinguisher ABC with metal holder and quick release	1	\$ 250.00	\$ 250.00
11.10	20 LB fire extinguisher ABC with metal holder and quick release		\$ 310.00	\$ -
11.11	Vinyl cover and maintence tag with protective sleeve for fire extinguishers		\$ 125.00	\$ -
11.12	Metal hand tool box		\$ 280.00	\$ -
11.13	small plastic hand tool box		\$ 190.00	\$ -
11.14	5 piece tool holder for lutes, brooms,shovels	1	\$ 190.00	\$ 190.00
11.15	2 piece shovle holder for shovel heads down ,prevents solvent dripping on handle afer dipping		\$ 190.00	\$ -
11.16	shovel cleaning tank, flip lid ear entry with rubber splash shield, holds 2 shovels	1	\$ 290.00	\$ 290.00
11.17	lute cleaning tank holds 2 lutes		\$ 490.00	\$ -
11.18	15 gallon plastic water jug for filling water tanks on tools, mounted in metal holder		\$ 350.00	\$ -
11.19	5 gallon drinking jug mounted in metal holder		\$ 200.00	\$ -
11.20	small spoils bin with gravity dispensing		\$ 890.00	\$ -
11.21	cone holder		\$ 150.00	\$ -
11.22	metal holder for 6 x 6 hand tamper includes tamper		\$ 290.00	\$ -
11.23	SMV metal rear mount		\$ 120.00	\$ -
12.0	<b>Delivery Charges</b>			
12.1	<b>Delivery Starting Point - City, State, Zip</b> <b>333 2nd Street NE, Hopkins, MN 55343</b>			
	<b>Price per loaded mile</b>	330	1.75	\$ 577.50
13.0	<b>New Equipment Rental Program NA</b>			
14.0	<b>Vendor Owned Rental Return or Demo Equipment NA</b>			
15.0	<b>Discount Off List Price For Related Parts and Accessories NA</b>			
	<b>Total</b>			<b>\$ 52,817.50</b>

## Pothole Patch/Recycler

VENDOR NAME: Falcon Road Maintenance Equipment, LLC  
 MAKE/MODEL: 4 TON TANDEM AXLE TRAILER

**Total \$ 53,697.66**

Spec #	Description	Qty	Price	Subtotal
--------	-------------	-----	-------	----------

1.0	Price for Pothole Patch/Recycler base unit:	1	\$ 21,817.30	\$ 21,817.30
-----	---	---	--------------	--------------

**FOR OPTIONAL ITEMS AVAILABLE IN LIEU OF THE STANDARD ITEMS OFFERED, THE PRICE SHALL BE THE DIFFERENCE PAID TO ACHIEVE THE UPGRADE RATHER THAN THE FULL PURCHASE PRICE. IF THE OPTION COST IS LESS THAN THE BASE UNIT OFFERED, THE PRICE SHOULD BE OFFERED AS A DEDUCT.**

**2.0 Hopper Options:**  
 Use this section to offer hopper options such as hopper sizes, doors, work platforms, etc.. Add as many lines as needed. If not offering items in this section delete lines and add "NA" after section Header.

2.1	Catwalk for Pothole patch units must meet OSHA 29CFR-1910, Subpart D		\$ 969.90	\$ -
2.2	Front and Rear Hopper Extensions		\$ 544.84	\$ -
2.3	Deduct for 3-Ton Hopper		\$ (514.10)	\$ -

**3.0 Burner/Heater Options:**  
 Use this section to offer burner/heater options such as CNG fuel, vapor or liquid LP, radiant, fuel tank size and options, etc.. Add as many lines as needed. If not offering items in this section delete lines and add "NA" after section Header.

3.1	Cold Weather Package - Beckett Diesel Fuel Pre-Heater (Price per diesel burner)		\$ 310.58	\$ -
3.2	Dual Burner Recycling Package with 24-Hour Timer (Propane or Diesel)		\$ 4,746.68	\$ -
3.3	Dual Burner Recycling Package with 7-Day Timer (Propane or Diesel)		\$ 4,871.76	\$ -
3.4	Electric Overnight Heat - 110V (Includes four 750 watt heating elements and two 110V plugs)	1	\$ 2,354.26	\$ 2,354.26
3.5	Electric Overnight Heat - 240V (Includes two 1,500 watt heating elements)	0	\$ 2,688.16	\$ -
3.6	Oil-Jacketed Hopper	1	\$ 3,721.66	\$ 3,721.66
3.7	Cold Weather Package - 12V System		\$ 1,272.00	\$ -
3.8	Liquid Propane Burner (In place of vapor propane)	1	\$ 200.34	\$ 200.34

**4.0 Torch/Sprayer Options:**  
 Use this section to offer options such as torches, emulsion sprayers, etc.. Add as many lines as needed. If not offering items in this section delete lines and add "NA" after section Header.

4.1	Hand-Held Torch with Mounting Bracket for 20-LB Propane Tank (Tank not supplied)		\$ 482.30	\$ -
4.2	Spray System for Heated Tack Tank - High Volume (for water-based tack - 5.5 HP Honda Motor - Viking HL32 Pump - 1/2" Hoses)	1	\$ 3,412.14	\$ 3,412.14

**5.0 Hose Reel Options:**  
 Use this section to offer hose reel options. Add as many lines as needed. If not offering items in this section delete lines and add "NA" after section Header.

5.1	Hose Reel for Propane Torch (Vicon Seal)		\$ 750.48	\$ -
5.2	Hose Reel for 5.5 HP Spray System (25 ft 1/2" Hose)	1	\$ 716.56	\$ 716.56
5.3	Hose Reel for Washdown System		\$ 716.56	\$ -

**6.0 Tank Options:**

Use this section to offer options such as tack tanks, solvent tanks, water tanks, etc.. Add as many lines as needed. If not offering items in this section delete lines and add "NA" after section Header.

6.1	30 gallon non-heated / non-insulated / gravity feed tack tank		\$ 1,125.72	\$ -
6.2	30 gallon heated / insulated / gravity feed tack tank (Matches hopper heat source - requires extended frame option)	1	\$ 3,582.80	\$ 3,582.80
6.3	30 gallon heated / insulated / gravity feed/ oil-jacketed / AC Melter tack tank (Matches hopper heat source - requires extended frame option - two thermocouples and two digital temp controllers)		\$ 6,175.56	\$ -
6.4	50 gallon heated / insulated / gravity feed tack tank (Matches hopper heat source - requires extended frame option)		\$ 4,551.64	\$ -

**7.0 Trailer Options:**

Use this section to offer additional trailer options such as different hitches, brakes, spare tire, Spare tire mount, LED lights, etc.. These should be trailer options only. Add as many lines as needed. If not offering items in this section delete lines and

7.1	Bracket for Hydraulic Pendant Mounted on Rear of Trailer (each)		\$ 41.34	\$ -
7.2	Dump Trailer (Power up and Gravity Down)		\$ 4,686.26	\$ -
7.3	Dump Trailer (Power up and Power Down)	1	\$ 4,994.72	\$ 4,994.72
7.4	Single Frame Extension	1	\$ 214.12	\$ 214.12
7.5	Double Frame Extension (includes frame rail upgrade to 2 x 8 tubing and two 7K torsion axles)		\$ 1,979.02	\$ -
7.6	Triple Frame Extension (includes frame rail upgrade to 2 x 10 tubing and two 7K torsion axles)		\$ 2,626.68	\$ -
7.7	Extended Trailer Hitch (1 extra foot)		\$ 186.56	\$ -
7.8	Extended Trailer Hitch (2 extra feet) (for electric brakes only)	1	\$ 220.48	\$ 220.48
7.9	Heavy-Duty Safety Chain Anchors	1	\$ 193.98	\$ 193.98
7.10	Spare Tire with 8-bolt wheel and 9 x 14.5 Tire	0	\$ 255.46	\$ -
7.11	Spare Tire with 8-bolt wheel and 16" Tire	1	\$ 289.38	\$ 289.38
7.12	Spare Tire Holder Mounted to Frame		\$ 310.58	\$ -
7.13	Surge Brakes Tandem Leaf Spring Axle Frame Only (Free Backing)		\$ 1,357.86	\$ -
7.14	Torsion Axles (Two 7K Axles)	1	\$ 852.24	\$ 852.24
7.15	9k Trailer Suspension Upgrade (Slipper Spring Axle Trailer Only)		\$ 1,171.30	\$ -
7.16	16" Tire Upgrade (ST235/80 R16 Tires)		\$ 620.10	\$ -

**8.0 Cab & Chassis Options: NA**

Use this section to offer cab & chassis options for truck mounted units. Add as many lines as needed. If not offering items in this section delete lines and add

**9.0 Lighting Options:**

Use this section to offer lighting options such as warning lights, work lights, etc.. Add as many lines as needed. If not offering items in this section delete lines and add "NA" after section Header.

9.1	Strobe Warning Light - Mounting Bracket on Front Hopper Wall (each)		\$ 434.60	\$ -
9.2	Strobe Warning Light - Mounting Bracket on Rear Hopper Loading Door (each)	2	\$ 224.72	\$ 449.44
9.3	LED Upgrade (Four 4" LED Stop/Tail/Turn, LED marker and ID Bar)		\$ 310.58	\$ -
9.4	LED Upgrade (Two 4" LED Stop/Tail/Turn, 2 4" Amber Strobe, LED marker and ID Bar)	1	\$ 381.60	\$ 381.60



9.5	LED Upgrade (Four 4" LED Stop/Tail/Turn, 2 4" Amber Strobe, LED marker and ID Bar)		\$ 537.42	\$ -
9.6	Arrow Stick (LED)	1	\$ 1,196.74	\$ 1,196.74
9.7	Backup Lights		\$ 231.08	\$ -
9.8	Night Work Lights (LED)		\$ 418.70	\$ -
10.0	<b>Arrow Board Options:</b> Use this section to offer arrow board options. Add as many lines as needed. If not offering items in this section delete lines and add "NA" after section Header.			
10.1	Arrow Board (Non-LED)		\$ 1,417.22	\$ -
10.2	Arrow Board (LED)		\$ 1,861.36	\$ -
11.0	<b>Other Options:</b> Use this section to offer options not already stated and only ones that are attached to or specific to Pothole Patch / Asphalt Recycler Units. Add as many lines as needed. If not offering items in this section delete lines and add "NA" after section Header.			
11.1	Upgrade to Hydraulic Unloading and Loading Doors	1	\$ 3,652.76	\$ 3,652.76
11.2	Upgrade to Hydraulic Unloading Door Only		\$ 1,665.26	\$ -
11.3	Bracket for Release Agent Sprayer (8" x 8")		\$ 292.56	\$ -
11.4	Release Agent Tank		\$ 314.82	\$ -
11.5	Solvent Dip Tank	1	\$ 281.60	\$ 281.60
11.6	Mounting Bracket with Tack Distributor		\$ 276.66	\$ -
11.7	Upright Tack Pour Pot Mounting Bracket Only		\$ 172.78	\$ -
11.8	Compactor Basket (24" x 24" ID)	1	\$ 3,112.88	\$ 3,112.88
11.9	Compactor Basket (30" x 30" ID)		\$ 358.28	\$ -
11.10	Hoist with manual winch (For Lifting 250 LBS)		\$ 744.12	\$ -
11.11	Hoist with 12-Volt Winch (For lifting 250 LBS)		\$ 1,068.48	\$ -
11.12	Hoist with 12-Volt Winch (For lifting 550 LBS)		\$ 1,316.52	\$ -
11.13	Water Tank (15-Gallon Capacity) with Mounting Bracket		\$ 428.24	\$ -
11.14	Backup Alarm		\$ 172.78	\$ -
11.15	Document Holder		\$ 103.88	\$ -
11.16	Emergency Stop Button		\$ 385.84	\$ -
11.17	Fire Extinguisher (5 pound) with mounting bracket		\$ 220.48	\$ -
11.18	Fire Extinguisher (10 pound) with mounting bracket		\$ 272.42	\$ -
11.19	Hour Meter (For Primary Burner)		\$ 172.78	\$ -
11.20	Loading Doors Gas Assist Shocks		\$ 395.38	\$ -
11.21	Slow Moving Vehicle Decal		\$ 68.90	\$ -
11.22	Step to Hopper Access Platform (each)		\$ 210.94	\$ -
11.23	Thermometer 50/550 - Rear Analog		\$ 425.06	\$ -
11.24	Tool Box (10 x 10 x 25)		\$ 386.90	\$ -
11.25	Tool Holder (2 positions)		\$ 103.88	\$ -
11.26	Tool Holder (3 positions)		\$ 117.66	\$ -
11.27	Tool Holder (5 positions)	1	\$ 170.66	\$ 170.66
11.28	Timer: 24-Hour		\$ 338.14	\$ -
11.29	Timer: 7-Day		\$ 462.16	\$ -
11.30	Washdown System (12V Pump / 5-Gallon Reservoir)		\$ 792.88	\$ -
11.31	Wheel Chocks with Mounting Bracket		\$ 241.68	\$ -
11.32	Infrared Transporter Package - Includes Hoist w/ 12-Volt Winch for Lifting 550 lbs., Infrared Mounting Basket and <u>Double</u> Frame Extension		\$ 3,763.00	\$ -
11.33	Infrared Transporter Package - Includes Hoist w/ 12-Volt Winch for Lifting 550 lbs., Infrared Mounting Basket and <u>Triple</u> Frame Extension		\$ 4,503.94	\$ -
11.34	4x4 Portable Infrared split-channel heater / Requires purchase of item 11.32 if mounting on trailer is required		\$ 6,557.25	\$ -
11.35	4x6 Portable Infrared split-channel heater / Requires purchase of item 11.33 if mounting on trailer is required		\$ 7,817.25	\$ -

11.36	Bomag Plate Compactor BVP18/45-2W w/ Wheels	\$ 3,029.48	\$ -
11.37	Vibco Roller GR1600	\$ 2,463.44	\$ -
11.37	Vibco Roller GR3200	\$ 7,688.18	\$ -
11.38	3" Pintle	\$ 74.80	\$ -

12.0 **DELIVERY CHARGES - SEE SPECIAL TERMS AND CONDITIONS**  
**NO FLAT RATE ALLOWED**  
**DELIVERY STARTING POINT - City, State, Zip**  
Midland, MI, 48642

Price per loaded mile 941 | \$2.00 | \$ 1,882.00

13.0 **NEW EQUIPMENT RENTAL PROGRAM**

If rental programs are available on the new equipment offered, with the option to purchase, list the hourly/weekly/monthly rental rate. Indicate the percent of rental fee paid by the purchaser that will be applied to the purchase price. See Solicitation Special Terms & Conditions.

Hourly Rental Rate:	\$ -
Weekly Rental Rate:	\$ -
Monthly Rental Rate:	\$ -
Percent (%) of Rental Fee applied to purchase price:	\$ -

14.0 **VENDOR OWNED RENTAL RETURN OR DEMO EQUIPMENT PROGRAM**

See Solicitation Special Terms and Conditions.

**DEDUCT** cost per **Used Hour** from the original Contract Price \$ -

15.0 **DISCOUNT OFF LIST PRICE FOR RELATED PARTS**

**AND ACCESSORIES** - (See Special Terms and Conditions)

**Price List Date and Number**

**Total \$ 31,880.36**





**PUBLIC WORKS  
OPERATIONS**

26

Fleet Management, Forestry,  
Streets & Sewers,  
Watermains & Hydrants  
402 23rd STREET NORTH  
FARGO, NORTH DAKOTA 58102  
PHONE: (701) 241-1453  
FAX: (701) 241-8100

September 28, 2018

The Honorable Board of City Commissioners  
City of Fargo  
200 North 3<sup>rd</sup> Street  
Fargo, ND 58102

RE: Authorization to extend 2016/2017 snow hauling contracts with Master Construction, Diesel Dogs Trucking and Industrial Builders for the 2018-2019 snow season.

Commissioners:

In October of 2016, Public Works issued a Request for Proposal (RFP) for trucking services in association with snow hauling for the 2016/2017 snow season. Upon the closing of the RFP a total of three (3) sealed responses were received (see attached bid tab). Based on the established evaluation criteria, contracts were extended to Master Construction, Diesel Dogs Trucking and Industrial Builders. As part of 2016/2017 RFP, language was included that allows for two (2) one (1) year extensions under the original terms of the RFP. Public Works staff has visited with all three 2016/2017 contract holders and at this time is requesting authorization to extend their contracts for the 2018/2019 snow season under the terms of the initial 2016 RFP (RFP17012, RFP17013 and RFP17014).

- Master Construction (7 Trucks)
- Diesel Dogs Trucking (7 Trucks)
- Industrial Builders (5 Trucks)

RECOMMENDED MOTION: I/we hereby move based on the request for proposal (RFP17012, RFP17013 and RFP17014) to extend the initial 2016/2017 snow hauling contracts with Master Construction, Diesel Dogs Trucking and Industrial Builders for the 2018/2019 snow season.

Respectfully submitted,

Ben Dow  
Public Works  
Director of Operations

## SERVICES AGREEMENT

### SNOW HAULING

#### I. Agreement

This agreement is between the City of Fargo (City) and Diesel Dogs Trucking, LLC. (Contractor) to provide snow hauling services for the City. This agreement shall commence upon signing by both parties and expire on October 1, 2019. The term of this agreement may be extended, if accepted and signed by the Contractor and City, for one (1) additional one (1) year extensions, provided the extension is signed by parties on or before September 30 of the contract year.

#### II. Scope of Services

Contractor agrees to provide seven (7) quad, triaxle or side dump/trailer trucks for purposes of hauling snow to assist and supplement the City's snow hauling operations with the downtown area of City. All Contractor trucks must be capable of carrying a minimum of 11CY of snow per load. Contractor must ensure that all trucks are properly insured, registered and inspected. Contractor is responsible for the condition of the truck, and if unsatisfactory to the sole discretion of City, the truck will be removed from service and billable time will cease. Contractor is responsible for ensuring all drivers are properly licensed. Contractor must comply with all State, Federal and Local laws, regulations and ordinances applicable to the operation of Contractor's equipment.

#### III. Responsibility of the City

City shall oversee the execution of this agreement and disbursing of funds. City shall be entitled to verify the condition and registration of the truck, as well as contractor license/driver operators' license status.

#### IV. Contractor's Compensation and Method of Payment

City will reimburse Contractor at a rate of;

- \$75.00 11 to 15 cubic yard truck,
- \$90.00 15 to 20 cubic yard truck,
- \$110.00 per hour for each side dump/trailer truck,

commencing at the time of arrival of each truck at the location designated by the City, until such time the truck is released by the City, to the nearest ½ hour.

Contractor shall receive no less than \$2,500 per truck contracted for the snow season, provided Contractor is not in breach of the terms of this Agreement at the end of the snow season, defined as the last significant snowfall requiring snow hauling in the downtown area. Failure to provide the truck and driver when properly noticed shall be deemed a default. Termination prior to the end of the snow season shall be deemed a default, terminating the City's obligation to pay the minimum amount.

Final invoices shall be submitted no later than June 1 of the contract year. Contractor will be paid either the amount due for services rendered or the Minimum Contract Amount, whichever is greater.

**V. Termination of the Agreement**

This contract may be terminable at will by either party after giving ten (10) days written notice to the other party.

**VI. Assignability**

This agreement will not be assigned or transferred by Contractor to another party without the prior written consent of the City.

**VII. Hold Harmless and Insurance**

Contractor agrees to indemnify and hold City harmless from any and all claims, demands or causes of action resulting from the provision of services as described in this contract. Contractor's employees must be covered by North Dakota's Workers Compensation. Contractor shall carry appropriate liability insurance coverage, including but not limited to Public Liability Insurance in the amount of \$1,000,000 per person, \$500,000 per accident, and property damage in the amount of \$300,000 per accident. Contractor shall provide City as Certificate of Insurance naming the City of Fargo as an additional insured, and such insurance must be maintained during the term of this Agreement and any extension agreed to thereafter.

**VIII. Contractor Records**

Contractor shall maintain accurate and updated records of all reimbursable services provided to City under the terms of this agreement, and shall record the date such services are provided. Such records shall conform to generally recognized accounting principles. The City, or their authorized representatives, shall have access to any records of Contractor pertinent to the agreement.

**IX. Monitoring and Evaluation**

City may monitor and evaluate Contractor progress and performance to assure that the terms of this agreement are being satisfactorily met. Contractor shall cooperate with City relating to such monitoring and evaluation.

**X. Independence of Recipient**

Contractor is not the agent or employee of City. Contractor is solely responsible for its acts and the acts of its agents, employees and subcontractors.

**XI. Conflict of Interest**

Contractor agrees that it does not have any undisclosed influence or relationship with City staff regarding the award or performance of this contract.

**XII. Entire Agreement**

The provisions as set forth in Items I, and all attachments of this agreement constitute the entire agreement between the parties.

IN WITNESS WHEREOF, the undersigned enter into this agreement.

Date: 9-21-18

CONTRACTOR

  
Dan Kraemer, President/Owner

Date: \_\_\_\_\_

CITY OF FARGO, North Dakota, a North  
Dakota Municipal Corporation

\_\_\_\_\_  
Timothy J. Mahoney, Mayor

ATTEST:

\_\_\_\_\_  
Steve Sprague, City Auditor

## SERVICES AGREEMENT

### SNOW HAULING

#### I. Agreement

This agreement is between the City of Fargo (City) and Industrial Builders, Inc. (Contractor) to provide snow hauling services for the City. This agreement shall commence upon signing by both parties and expire on October 1, 2019. The term of this agreement may be extended, if accepted and signed by the Contractor and City, for one (1) additional one (1) year extensions, provided the extension is signed by parties on or before September 30 of the contract year.

#### II. Scope of Services

Contractor agrees to provide five (5) quad, triaxle or side dump/trailer trucks for purposes of hauling snow to assist and supplement the City's snow hauling operations with the downtown area of City. All Contractor trucks must be capable of carrying a minimum of 11CY of snow per load. Contractor must ensure that all trucks are properly insured, registered and inspected. Contractor is responsible for the condition of the truck, and if unsatisfactory to the sole discretion of City, the truck will be removed from service and billable time will cease. Contractor is responsible for ensuring all drivers are properly licensed. Contractor must comply with all State, Federal and Local laws, regulations and ordinances applicable to the operation of Contractor's equipment.

#### III. Responsibility of the City

City shall oversee the execution of this agreement and disbursing of funds. City shall be entitled to verify the condition and registration of the truck, as well as contractor license/driver operators' license status.

#### IV. Contractor's Compensation and Method of Payment

City will reimburse Contractor at a rate of;

- \$105.00 11 to 15 cubic yard truck,
- \$125.00 15 to 20 cubic yard truck,
- \$140.00 side dump/trailer truck,

commencing at the time of arrival of each truck at the location designated by the City, until such time the truck is released by the City, to the nearest ½ hour.

Contractor shall receive no less than \$2,500 per truck contracted for the snow season, provided Contractor is not in breach of the terms of this Agreement at the end of the snow season, defined as the last significant snowfall requiring snow hauling in the downtown area. Failure to provide the truck and driver when properly noticed shall be deemed a default. Termination prior to the end of the snow season shall be deemed a default, terminating the City's obligation to pay the minimum amount.

Final invoices shall be submitted no later than June 1 of the contract year. Contractor will be paid either the amount due for services rendered or the Minimum Contract Amount, whichever is greater.

**V. Termination of the Agreement**

This contract may be terminable at will by either party after giving ten (10) days written notice to the other party.

**VI. Assignability**

This agreement will not be assigned or transferred by Contractor to another party without the prior written consent of the City.

**VII. Hold Harmless and Insurance**

Contractor agrees to indemnify and hold City harmless from any and all claims, demands or causes of action resulting from the provision of services as described in this contract. Contractor's employees must be covered by North Dakota's Workers Compensation. Contractor shall carry appropriate liability insurance coverage, including but not limited to Public Liability Insurance in the amount of \$1,000,000 per person, \$500,000 per accident, and property damage in the amount of \$300,000 per accident. Contractor shall provide City as Certificate of Insurance naming the City of Fargo as an additional insured, and such insurance must be maintained during the term of this Agreement and any extension agreed to thereafter.

**VIII. Contractor Records**

Contractor shall maintain accurate and updated records of all reimbursable services provided to City under the terms of this agreement, and shall record the date such services are provided. Such records shall conform to generally recognized accounting principles. The City, or their authorized representatives, shall have access to any records of Contractor pertinent to the agreement.

**IX. Monitoring and Evaluation**

City may monitor and evaluate Contractor progress and performance to assure that the terms of this agreement are being satisfactorily met. Contractor shall cooperate with City relating to such monitoring and evaluation.

**X. Independence of Recipient**

Contractor is not the agent or employee of City. Contractor is solely responsible for its acts and the acts of its agents, employees and subcontractors.

**XI. Conflict of Interest**

Contractor agrees that it does not have any undisclosed influence or relationship with City staff regarding the award or performance of this contract.

**XII. Entire Agreement**

The provisions as set forth in Items I, and all attachments of this agreement constitute the entire agreement between the parties.

IN WITNESS WHEREOF, the undersigned enter into this agreement.

Date: 9-26-18

CONTRACTOR

INDUSTRIAL ENTERPRISES INC.

By: [Signature]

Its: Vice Pres. Const.  
ROGER HABERMANN

Date: \_\_\_\_\_

CITY OF FARGO, North Dakota, a North Dakota Municipal Corporation

\_\_\_\_\_  
Timothy J. Mahoney, Mayor

**ATTEST:**

Steve Sprague, City Auditor



## SERVICES AGREEMENT

### SNOW HAULING

#### I. Agreement

This agreement is between the City of Fargo (City) and Master Construction Company, Inc. (Contractor) to provide snow hauling services for the City. This agreement shall commence upon signing by both parties and expire on October 1, 2019. The term of this agreement may be extended, if accepted and signed by the Contractor and City, for one (1) additional one (1) year extensions, provided the extension is signed by parties on or before September 30 of the contract year.

#### II. Scope of Services

Contractor agrees to provide seven (7) quad, triaxle or side dump/trailer trucks for purposes of hauling snow to assist and supplement the City's snow hauling operations with the downtown area of City. All Contractor trucks must be capable of carrying a minimum of 11CY of snow per load. Contractor must ensure that all trucks are properly insured, registered and inspected. Contractor is responsible for the condition of the truck, and if unsatisfactory to the sole discretion of City, the truck will be removed from service and billable time will cease. Contractor is responsible for ensuring all drivers are properly licensed. Contractor must comply with all State, Federal and Local laws, regulations and ordinances applicable to the operation of Contractor's equipment.

#### III. Responsibility of the City

City shall oversee the execution of this agreement and disbursing of funds. City shall be entitled to verify the condition and registration of the truck, as well as contractor license/driver operators' license status.

#### IV. Contractor's Compensation and Method of Payment

City will reimburse Contractor at a rate of;

- \$80.00 11 to 15 cubic yard truck,

commencing at the time of arrival of each truck at the location designated by the City, until such time the truck is released by the City, to the nearest ½ hour.

Contractor shall receive no less than \$2,500 per truck contracted for the snow season, provided Contractor is not in breach of the terms of this Agreement at the end of the snow season, defined as the last significant snowfall requiring snow hauling in the downtown area. Failure to provide the truck and driver when properly noticed shall be deemed a default. Termination prior to the end of the snow season shall be deemed a default, terminating the City's obligation to pay the minimum amount.

Final invoices shall be submitted no later than June 1 of the contract year. Contractor will be paid either the amount due for services rendered or the Minimum Contract Amount, whichever is greater.

**V. Termination of the Agreement**

This contract may be terminable at will by either party after giving ten (10) days written notice to the other party.

**VI. Assignability**

This agreement will not be assigned or transferred by Contractor to another party without the prior written consent of the City.

**VII. Hold Harmless and Insurance**

Contractor agrees to indemnify and hold City harmless from any and all claims, demands or causes of action resulting from the provision of services as described in this contract. Contractor's employees must be covered by North Dakota's Workers Compensation. Contractor shall carry appropriate liability insurance coverage, including but not limited to Public Liability Insurance in the amount of \$1,000,000 per person, \$500,000 per accident, and property damage in the amount of \$300,000 per accident. Contractor shall provide City as Certificate of Insurance naming the City of Fargo as an additional insured, and such insurance must be maintained during the term of this Agreement and any extension agreed to thereafter.

**VIII. Contractor Records**

Contractor shall maintain accurate and updated records of all reimbursable services provided to City under the terms of this agreement, and shall record the date such services are provided. Such records shall conform to generally recognized accounting principles. The City, or their authorized representatives, shall have access to any records of Contractor pertinent to the agreement.

**IX. Monitoring and Evaluation**

City may monitor and evaluate Contractor progress and performance to assure that the terms of this agreement are being satisfactorily met. Contractor shall cooperate with City relating to such monitoring and evaluation.

**X. Independence of Recipient**

Contractor is not the agent or employee of City. Contractor is solely responsible for its acts and the acts of its agents, employees and subcontractors.

**XI. Conflict of Interest**

Contractor agrees that it does not have any undisclosed influence or relationship with City staff regarding the award or performance of this contract.

**XII. Entire Agreement**

The provisions as set forth in Items I, and all attachments of this agreement constitute the entire agreement between the parties.

**IN WITNESS WHEREOF**, the undersigned enter into this agreement.

Date: Sept 24, 2018

CONTRACTOR

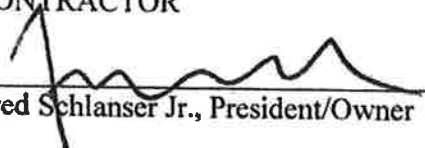
  
\_\_\_\_\_  
Fred Schlanser Jr., President/Owner

Date: \_\_\_\_\_

CITY OF FARGO, North Dakota, a North  
Dakota Municipal Corporation

\_\_\_\_\_  
Timothy J. Mahoney, Mayor

ATTEST:

\_\_\_\_\_  
Steve Sprague, City Auditor



27

PUBLIC WORKS/OPERATIONS

Fleet Management, Forestry, Streets & Sewers, Watermeters, Watermains & Hydrants 402 23rd STREET NORTH FARGO, NORTH DAKOTA 58102 PHONE: (701) 241-1453 FAX: (701) 241-8100

October 4, 2018

The Honorable Board of City Commissioners City of Fargo 225 Fourth Street North Fargo, ND 58102

RE: 2019 Fire Pumper Purchase (PBC18071)

Commissioners:

A cost evaluation process was started in December for the purchase of a new Fire Pump Truck. Multiple vendors were contacted and proposals evaluated. It was determined that utilizing a purchasing consortium was the best solution for the purchase. The Houston/Galveston Area Co-op (HGAC) has contract number FS12-17 (Fire Service Apparatus) available that meets all of the City of Fargo purchasing guidelines.

The review committee, consisting of Chief Dirksen, Lee Soeth, Gary Lorenz and Allan Erickson, determined which proposals met the specifications required. It is our recommendation to purchase our 2019 Fire Pump Truck from this same contract that is still open from Spartan ERV using the HGAC Buying contract. If ordered before November 1st, 2018 there will be approximately a 12% savings to the budget for this Pump Truck as the 2018 pricing will still be in effect. Funding for this project is included in the 2019 Vehicle Replacement Budget.

SUGGESTED MOTION:

Approve the recommendation to purchase one (1) Spartan Fire Pumper thru HGACBuy for the total amount of \$463,936.00.

Respectfully Submitted,

[Handwritten signature]

Tanner Smedshammer Fleet Management Specialist





28

October 4, 2018

Honorable Board of City Commissioners  
City of Fargo  
Fargo, North Dakota 58102

RE: Project SW 16-03

Dear Commissioners:

Bids were opened at 11:30 AM on Wednesday, October 3, 2018, for the Landfill Gas Compression Plant Expansion Project SW16-03. Bids were requested in a *Multiple Prime Contractor* format (*General, Mechanical, and Electrical*) and a *Single Prime Contractor* format. A detailed combined bid tabulation sheet has been attached for your review.

Based on the attached bid results, this office recommends award of three *Multiple Prime Contracts* with **Gast Construction Company, Inc., for \$580,322; Robert Gibb & Sons for \$699,950; and Rickard Electric Inc. for \$534,830** as the lowest and best bids. Funding for construction of Project SW 16-03 is provided for in the 2018 Solid Waste Division budget. Please note that the *Engineer's Estimate* for this project was \$1,352,600, and that the overall project cost was within 40% of the estimate.

**SUGGESTED MOTION:**

Accept the bids and award contracts with Gast Construction Company, Inc., for \$580,322; Robert Gibb & Sons for \$699,950; and Rickard Electric Inc. for \$534,830 for the Landfill Gas Compression Plant Expansion Project SW16-03.

Respectfully Submitted,

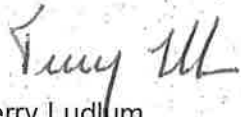

Terry Ludlum  
Solid Waste Utility Director

Attachment:

cc: Bruce Grubb, City Administrator  
Jill Pagel, Auditors Office  
Paul Hanson, Landfill Foreman  
Randy Hanson, Wenck Associates





# Bid Tab – Multiple Prime

## Fargo Landfill, Gas Compression System Expansion

*Wednesday, October 3, 2018 / 11:30 AM | Fargo City Hall*

Plan Holder	5% Bid Bond	Contr. License	Contract A General	Contract B Mechanical	Contract C Electrical	Optional Bid Items	Combined
<b>Multiple Prime - General Contractor</b>							
Gast Construction Co., Inc.	X	X	\$547,335	No Bid	No Bid	\$32,987	\$580,322
<b>Multiple Prime - Mechanical Contractors</b>							
Robert Gibb & Sons	X	X	No Bid	\$699,950	No Bid	No Bid	\$699,950
Peterson Mechanical, Inc.	X	X	No Bid	\$767,200	No Bid	\$19,200	\$786,400
Wrigley Mechanical, Inc.	X	X	No Bid	\$1,245,800	No Bid	\$4,700	\$1,250,500
<b>Multiple Prime - Electrical Contractors</b>							
Rickard Electric Inc.	X	X	No Bid	No Bid	\$534,830	None	\$534,830
Sun Electric, Inc.	X	X	No Bid	No Bid	\$740,000	None	\$740,000
<b>Lowest Each Contract &amp; Total Project Cost</b>			<b>\$547,335</b>	<b>\$699,950</b>	<b>\$534,830</b>	<b>\$32,987</b>	<b>\$1,815,102</b>

**Certification:**

I certify that these bids were received and opened on Wednesday, October 3, 2018 at 11:30 AM at Fargo City Hall, Meadow Lark Room, 225 4 St N, Fargo, ND.

Terry Ludlum, Solid Waste Utility Director



## Bid Tab – Single Prime

### Fargo Landfill, Gas compression System Expansion

*Wednesday, October 3, 2018 | 11:30 AM | Fargo City Hall*

Plan Holder	5% Bid Bond	Contr. License	Total	Optional Bid Item #1	Optional Bid Item #2	Combined
<b>Single Prime Contractor</b>						
NONE RECEIVED						

**Certification:**  
 I certify that these bids were received and opened on Wednesday, October 3, 2018 at 11:30 AM at Fargo City Hall, Meadow Lark Room, 225 4 St N, Fargo, ND.

  
 Terry Ludlum, Solid Waste Utility Director



Bids Opened: 11:30 AM  
Date: 10/3/2018

**CITY OF FARGO**  
**DIVISION OF SOLID WASTE**  
**Landfill Gas Compression System Improvements**  
**PROJECT SW 16-03**

Engineers Estimate: \$1,352,600

Bid Item	Quantity	Contractor Gast Construction	
		Unit Price	Extended Price
1 Site Mobilization/Demobilization	1 L.S.	\$5,000.00	\$5,000.00
2 Coordination of Project Execution and Schedule and Secure Building Permit	1 L.S.	\$5,000.00	\$5,000.00
3 Removal and Storage of Existing Equipment to be Re-Installed	1 L.S.	\$6,000.00	\$6,000.00
4 Removal and Relocation of Equipment Designated for Salvage	1 L.S.	\$4,000.00	\$4,000.00
5 Site Utilities and Finished Grading	1 L.S.	\$1,800.00	\$1,800.00
6 Furnish and Install Building and Equipment Concrete Foundations	1 L.S.	\$91,433.00	\$91,433.00
7 Building Structural Improvements	1 L.S.	\$299,992.00	\$299,992.00
8 Building Architectural Improvements	1 L.S.	\$32,000.00	\$32,000.00
9 Furnish and Install Fire Suppression System Water Supply Line and Fire Hydrant	1 L.S.	\$23,921.00	\$23,921.00
10 Furnish and Install 2-inch Water Service Line and Corp Stop to Building	1 L.S.	\$3,965.00	\$3,965.00
11 Delivery and Installation of Temporary Candlestick Flare and Blower Station	1 L.S.	\$15,250.00	\$15,250.00
12 Monthly Rental Rate for Temporary Candlestick Flare and Blower Station	4 E.A.	\$5,431.00	\$21,724.00
13 Decommissioning and Shipment of Temporary Flare back to Supplier	1 L.S.	\$7,250.00	\$7,250.00
14 Optional Bid Item 1 - Furnish and Install Foamed In Place Insulation	1 L.S.	\$32,987.00	\$32,987.00
<b>BID TOTAL</b>			<b>\$580,322.00</b>

Bid Item	Quantity	Contractor Wrigley Mechanical, Inc.		Contractor Peterson Mechanical		Contractor Robert Gibb & Sons	
		Unit Price	Extended Price	Unit Price	Extended Price	Unit Price	Extended Price
1 Site Mobilization/Demobilization	1 L.S.	\$14,800.00	\$14,800.00	\$4,000.00	\$4,000.00	\$18,760.00	\$18,760.00
2 Transportation of On-Site Equipment to Building Location for Installation	1 L.S.	\$18,000.00	\$18,000.00	\$10,000.00	\$10,000.00	\$16,750.00	\$16,750.00
3 Off-Loading of Equipment Delivered to Site for Installation	1 L.S.	\$43,000.00	\$43,000.00	\$10,000.00	\$10,000.00	\$2,325.00	\$2,325.00
4 New and Existing Equipment Installation and Setting	1 L.S.	\$284,000.00	\$284,000.00	\$200,000.00	\$200,000.00	\$45,710.00	\$45,710.00
5 Furnish and Install Air Diaphragm Pump	1 L.S.	\$4,500.00	\$4,500.00	\$5,000.00	\$5,000.00	\$3,600.00	\$3,600.00
6 Furnish and Install Large Diameter Piping	1 L.S.	\$274,000.00	\$274,000.00	\$150,000.00	\$150,000.00	\$232,145.00	\$232,145.00
7 Furnish and Install Small Bore Piping	1 L.S.	\$129,000.00	\$129,000.00	\$43,000.00	\$43,000.00	\$27,600.00	\$27,600.00
8 Install Vendor Supplied Valves and Appurtenances	1 L.S.	\$22,000.00	\$22,000.00	\$30,000.00	\$30,000.00	\$4,260.00	\$4,260.00
9 Furnish and Install Non-Vendor Supplied Valves and Appurtenances	1 L.S.	\$9,000.00	\$9,000.00	\$8,900.00	\$8,900.00	\$7,210.00	\$7,210.00
10 Furnish and Install HVAC Equipment	1 L.S.	\$202,000.00	\$202,000.00	\$148,000.00	\$148,000.00	\$158,040.00	\$158,040.00
11 Installation of Vendor Supplied Instrumentation	1 L.S.	\$48,700.00	\$48,700.00	\$6,400.00	\$6,400.00	\$7,840.00	\$7,840.00
12 Furnish and Install Non-Vendor Supplied Instrumentation	1 L.S.	\$6,500.00	\$6,500.00	\$	\$	\$5,000.00	\$5,000.00
13 Furnish and Install Combustible Gas Detectors	8 E.A.	\$975.00	\$7,800.00	\$1,100.00	\$8,800.00	\$720.00	\$5,760.00
14 Furnish and Install Piping and H2S Vessel Heat Tracing and Insulation	1 L.S.	\$148,500.00	\$148,500.00	\$106,600.00	\$106,600.00	\$131,545.00	\$131,545.00
15 Furnish and Install Water Meter and 2-inch Diameter Building Water Service Line and Valve	1 L.S.	\$2,000.00	\$2,000.00	\$9,000.00	\$9,000.00	\$2,030.00	\$2,030.00
16 Design, Furnish, and Install Fire Protection System	1 L.S.	\$32,000.00	\$32,000.00	\$27,500.00	\$27,500.00	\$31,375.00	\$31,375.00
17 Optional Bid Item 2 - Install Electric Unit Heaters	3 E.A.	\$1,566.67	\$4,700.00	\$6,400.00	\$19,200.00	\$	\$0.00
<b>BID TOTAL</b>			<b>\$1,250,500.00</b>		<b>\$786,400.00</b>		<b>\$699,950.00</b>

**C. Multiple Prime Electrical**

Bid Item	Quantity	Contractor Sun Electric, Inc.		Contractor Rickard Electric	
		Unit Price	Extended Price	Unit Price	Extended Price
1 Site Mobilization/Demobilization	1 L.S.	\$10,000.00	\$10,000.00	\$500.00	\$500.00
2 Furnish and Install Site Electrical Supply Improvements	1 L.S.	\$20,000.00	\$20,000.00	62,250.00	\$62,250.00
3 Install Vendor Supplied Electrical Equipment	1 L.S.	\$50,000.00	\$50,000.00	38,425.00	\$38,425.00
4 Furnish and Install Non-Vendor Supplied Electrical Equipment	1 L.S.	\$50,000.00	\$50,000.00	59,650.00	\$59,650.00
5 Furnish and Install Electrical Distribution Conduits and Wiring	1 L.S.	\$85,000.00	\$85,000.00	4,860.00	\$4,860.00
6 Install Owner Supplied Network Rack and SCADA System and Provide Communications Cable	1 L.S.	\$7,000.00	\$7,000.00	3,435.00	\$3,435.00
7 Furnish and Install Control Equipment and SCADA System and Provide Programming, Check-Out, and Start-Up Services for Non-Vendor Supplied Equipment	1 L.S.	\$324,000.00	\$324,000.00	170,050.00	\$170,050.00
8 Furnish and Install Building Lighting, Emergency Lighting, and Fire Alarm System	1 L.S.	\$120,000.00	\$120,000.00	122,395.00	\$122,395.00
9 Furnish and Install Instrumentation Wiring and Conduits from Electrical Room to Instrument Loc	1 L.S.	\$74,000.00	\$74,000.00	73,265.00	\$73,265.00
<b>BID TOTAL</b>			<b>\$740,000.00</b>		<b>\$534,830.00</b>

**D. Single Prime**

Bid Item	Quantity	Unit Price	Extended Price
1 Site Mobilization/Demobilization	1 L.S.		
2 Removal and Storage of Existing Equipment to be Re-Installed	1 L.S.		
3 Removal and Relocation of Equipment Designated for Salvage	1 L.S.		
4 Site Utilities and Finished Grading	1 L.S.		
5 Furnish and Install Building and Equipment Concrete Foundations	1 L.S.		
6 Building Structural Improvements	1 L.S.		
7 Building Architectural Improvements	1 L.S.		
8 Transportation of On-Site Equipment to Building Location for Installation	1 L.S.		
9 Off-Loading of Equipment Delivered to Site for Installation	1 L.S.		
10 New and Existing Equipment Installation and Setting	1 L.S.		
11 Furnish and Install Air Diaphragm Pump	1 L.S.		
12 Furnish and Install Large Diameter Piping	1 L.S.		
13 Furnish and Install Small Bore Piping	1 L.S.		
14 Install Vendor Supplied Valves and Appurtenances	1 L.S.		
15 Furnish and Install Non-Vendor Supplied Valves and Appurtenances	1 L.S.		
16 Furnish and Install HVAC Equipment	1 L.S.		
17 Furnish and Install Site Electrical Supply Improvements	1 L.S.		
18 Install Vendor Supplied Electrical Equipment	1 L.S.		
19 Furnish and Install Non-Vendor Supplied Electrical Equipment	1 L.S.		
20 Furnish and Install Electrical Distribution Conduits and Wiring	1 L.S.		
21 Install Owner Supplied Network Rack and Conduit for Future Internet Communications Cable	1 L.S.		
22 Furnish and Install Control Equipment and SCADA System and Provide Programming, Check-Out, and Start-Up Services for Non-Vendor Supplied Equipment	1 L.S.		
23 Furnish and Install Building Lighting, Emergency Lighting, and Fire Alarm System	1 L.S.		
24 Installation of Vendor Supplied Instrumentation	1 L.S.		
25 Furnish and Install Non-Vendor Supplied Instrumentation	1 L.S.		
26 Furnish and Install Instrumentation Wiring and Conduits from Electrical Control Room to Instruir	1 L.S.		
27 Furnish and Install Combustible Gas Detectors	8 E.A.		
28 Furnish and Install Piping and H2S Vessel Heat Tracing and Insulation	1 L.S.		
29 Furnish and Install Fire Suppression System Water Supply Line and Fire Hydrant	1 L.S.		
30 Furnish and Install 2-Inch Water Service Line and Corp Stop to Building	1 L.S.		
31 Furnish and Install Water Meter and 2-Inch Diameter Building Water Service Line and Valve	1 L.S.		
32 Design, Furnish, and Install Fire Protection System	1 L.S.		
33 Delivery and Installation of Temporary Candlestick Flare and Blower Station	1 L.S.		
34 Monthly Rental Rate for Temporary Candlestick Flare and Blower Station	4 Month		
35 Decommissioning and Shipment of Temporary Flare Back to Supplier	1 L.S.		
<b>BID TOTAL</b>			<b>\$0.00</b>

Optional Bid Item 1 - Furnish and Install Foamed In Place Insulation  
 Optional Bid Item 2 - Furnish and Install Electric Unit Heaters

29

October 10, 2018

Board of City Commissioners  
City Hall - 200 N 3<sup>rd</sup> Street  
Fargo, ND 58102

Dear Commissioners:

The North Dakota Department of Transportation (ND DOT) has awarded \$494,275 in State Aid to the City of Fargo for the period July 1, 2017 – June 30, 2018. The award is an increase over last year's State Aid of \$426,711.

The requested motion is to approve the attached ND DOT State Aid contract number 38181487. Thank you.

Sincerely,



Julie Bommelman  
Transit Director  
City of Fargo

/attachment



# North Dakota Department of Transportation

Thomas K. Sorel  
Director

Doug Burgum  
Governor

September 17, 2018

Congratulations. You have been chosen to receive transit funding. Enclosed is the Contract Agreement. Following is the funding breakdown per county for your agency.

Fargo Metro Transit	Cass	\$494,275	\$494,275
---------------------	------	-----------	-----------

In order to begin the funding process, please:

1. Have your organization's president or chairman sign and date the agreement (under Contractor)—this signature **must be an authorized signatory** for your project. Please also submit a proof of authorization to sign if it is not the president or chairperson of your agency.
2. Have a witness sign and date the agreement (under Witness), and
3. Return it to the address listed below at your earliest convenience.

Return your signed agreement to:

NDDOT/Local Government Division  
Attn: Transit Office  
608 East Boulevard Avenue  
Bismarck, ND 58505-0700

If you have any questions or need assistance, please call the Transit Office at (701) 328-2542.

Sincerely,

Becky Hanson  
Public Transit Section Manager

Cc: Dan Farnsworth, Transportation Planner

**North Dakota Department of Transportation  
STATE AID FOR PUBLIC TRANSIT AGREEMENT**

This agreement is between the state of North Dakota, acting by and through its Director of Transportation, hereinafter referred to as NDDOT, whose address is 608 East Boulevard Avenue, Bismarck, North Dakota 58505-0700, and City of Fargo, a Government Entity, hereinafter referred to as the Contractor, whose address is 650 23<sup>rd</sup> Street North, Fargo, ND 58102.

WHEREAS, House Bill 1337 (NDCC 39-04.2) of the 1989 State Legislature established a Public Transportation Fund to provide state aid funds to political subdivisions and nonprofit corporations for the purpose of assisting in establishing and operating public transit systems and service in the state; and

WHEREAS, the Director of NDDOT has the responsibility of developing the transit program guidelines and administering the Public Transportation Fund; and

WHEREAS, the Contractor desires to receive the available state aid funds to assist in providing needed public transit services in the service area;

NOW, THEREFORE, IT IS AGREED:

**I.**

For the period of July 1, 2018, through June 30, 2019, the Contractor shall undertake and provide the transit services as described in the Contractor's application for state aid transit funds, which is on file with the NDDOT.

**II.**

**Costs.** NDDOT shall reimburse the Contractor for providing the transportation services, not to exceed \$494,275, provided costs are incurred in accordance with NDDOT program guidelines. (Copy of which will be provided upon request.) Requests for reimbursements will be allowed to be submitted to NDDOT quarterly. The final request for reimbursement must be submitted by close of business on the fifth (5<sup>th</sup>) business day following the termination date of this agreement.

**III.**

**Purchase and Disposal of Project Equipment.** The purchase and disposition of all project vehicles or equipment financed in whole or in part with state aid transit funds shall be undertaken by the Contractor in accordance with the state Office of Management and Budget regulations and NDDOT purchasing manual, copies of which will be provided upon request.

**IV.**

**Assignments.** The Contractor shall not assign nor transfer the Contractor's interests or duties under this agreement without the express written consent of the state.

**V.**

**Subcontracting.** The Contractor shall not assign any portion of the work under this agreement, execute any contract, or obligate itself in any manner with a third party with respect to its rights and responsibilities to this



agreement without written consent of NDDOT. Any agreement with a subcontractor does not create a contractual relationship between the NDDOT and the subcontractor.

**VI.**

**Merger and Waiver.** This agreement constitutes the entire agreement between the parties. No waiver consent, modification or change of terms of this agreement shall bind either party unless in writing and signed by both parties. Such waiver, consent, modification, or change, if made, shall be effective only in the specific instance and for the specific purpose given. There are no understandings, agreements, or representations, oral or written, not specified herein regarding this agreement. The Contractor, by the signature below of its authorized representative, hereby acknowledges that the Contractor has read this agreement, understands it, and agrees to be bound by its terms and conditions.

**VII.**

**Records and Reports.** The Contractor shall complete and submit all forms and reports as required by NDDOT. The Contractor shall also maintain supporting documentation for all costs charged to the project. All accounting documents shall be clearly identified, readily accessible, and where possible, kept separate and apart from all other such documents. All project records and documents shall be kept by the Contractor for three years after the termination date of this agreement.

**VIII.**

**Audit.** Entities that receive federal funds through NDDOT may be required to obtain an audit in accordance with 2 C.F.R. Part 200, Subpart F. A copy of such audit shall be submitted to NDDOT. Entities that spend less than \$750,000 of federal funds from all sources may be subject to reviews by NDDOT at its discretion. Additionally, all entities receiving federal funds through NDDOT shall certify whether a Single Audit has been completed as part of the annual Federal award process. These requirements are applicable to counties, cities, state agencies, Indian tribes, colleges, hospitals, and non-profit businesses.

**IX.**

**Amendments.** The terms of this agreement shall not be waived, altered, modified, supplemented, or amended in any manner whatsoever, except by written instrument signed by both parties.

**X.**

**Equipment Use.** The Contractor agrees that the project vehicles or equipment funded with state aid transit funds shall be used solely for providing public transit services in accordance with NDDOT program guidelines. Such vehicles or equipment shall be used for the duration of useful life. If any project vehicles or equipment are not used in this manner or are withdrawn from service before the end of useful life, the Contractor shall immediately notify NDDOT. The Contractor agrees that the vehicles or equipment shall not be used for charter service or exclusively for school busing.

**XI.**

**Insurance.** The Contractor shall maintain insurance coverage on the project vehicle(s) in an amount adequate to protect the fair market value of the vehicles throughout the duration of this agreement.

**XII.**



**Termination.** The contract may be terminated by mutual consent of both parties, or by either party upon 30 days notice, in writing and delivered by certified mail or in person.

**XIII.**

**Nondiscrimination – Compliance with Laws.** The Contractor agrees to comply with all applicable laws and rules, including, but not limited to, those relating to nondiscrimination, accessibility, and civil rights.

**XIV.**

**Risk Management.** The Risk Management Appendix, attached, is hereby incorporated into and made a part of this agreement.

EXECUTED the date last below signed.

WITNESS:

STEVE SARAGUE, City Auditor  
NAME (TYPE OR PRINT)

SIGNATURE

CONTRACTOR:

DR. Timothy J. MAHONEY  
NAME (TYPE OR PRINT)

SIGNATURE

MAYOR  
TITLE

DATE

APPROVED as to substance by:

LOCAL GOVERNMENT ENGINEER (TYPE OR PRINT)

SIGNATURE

DATE

NORTH DAKOTA  
DEPARTMENT OF TRANSPORTATION

DIRECTOR (TYPE OR PRINT)

SIGNATURE

DATE

CLA 3338 (Div. 38)  
L.D. Approved 5-3-90; 8-15



### Risk Management Appendix

#### **Routine\* Transit Agreements With Sovereign Entities and Political Subdivisions of the State of North Dakota:**

**Parties:** State – State of North Dakota, its agencies, officers and employees

**Governmental Entity** – The Governmental Entity executing the attached document, its agencies, officers and employees

**Governments** – State and Government Entity, as defined above

Each party agrees to assume its own liability for any and all claims of any nature including all costs, expenses and attorney's fees which may in any manner result from or arise out of this agreement.

Each party shall secure and keep in force during the term of this agreement, from insurance companies, government self-insurance pools or government self-retention funds, authorized to do business in North Dakota, the following insurance coverages:

- 1) **Commercial general liability and automobile liability** insurance – minimum limits of liability required of the Governmental Entity are **\$250,000 per person and \$500,000 per occurrence**. The minimum limits of liability required of the State are **\$250,000 per person and \$1,000,000 per occurrence**.
- 2) **Workers compensation** insurance meeting all statutory limits.
- 3) The policies and endorsements may not be canceled or modified without **thirty (30) days prior written notice** to the undersigned State representative.

**The State reserves the right to obtain complete, certified copies of all required insurance documents, policies, or endorsements at any time.**

Each party that hires subcontractors shall require any non-public subcontractors, prior to commencement of work set out under an agreement between that party and the non-public subcontractor, to:

Defend, indemnify, and hold harmless the Governments, their agencies, officers and employees, from and against claims based on the vicarious liability of the Governments or its agents, but not against claims based on the Government's contributory negligence, comparative and/or contributory negligence or fault, sole negligence, or intentional misconduct. The legal defense provided by the Subcontractor to the Governments under this provision must be free of any conflicts of interest, even if retention of separate legal counsel for the Governments is necessary. Subcontractor also agrees to defend, indemnify, and hold the Governments harmless for all costs, expenses and attorneys' fees incurred if the Governments prevail in an action against the Subcontractor in establishing and litigating the indemnification coverage provided herein. This obligation shall continue after the termination of this agreement.

Subcontractor shall secure and keep in force during the term of this agreement, from insurance companies, government self-insurance pools or government self-retention funds authorized to do business in North Dakota: 1) commercial general liability; 2) automobile liability; and 3) workers compensation insurance all covering the Subcontractor for any and all claims of any nature which may in any manner arise out of or result from this agreement. The minimum limits of liability required are \$250,000 per person and \$1,000,000 per occurrence for commercial general liability and automobile liability coverages, and statutory limits for workers compensation. The Governments shall be endorsed on the commercial general liability policy and automobile liability policy as additional insureds. Said endorsement shall contain a "Waiver of Subrogation" waiving any right of recovery the insurance company may have against the Governments as well as provisions that the policy and/or endorsement may not be canceled or modified without thirty (30) days prior written notice to the undersigned representatives of the Governments, and that any attorney who represents the State under this policy must first qualify as and be appointed by the North Dakota Attorney General as a Special Assistant Attorney General as required under N.D.C.C. Section 54-12-08. Subcontractor's insurance coverage shall be primary (i.e., pay first) as respects any insurance, self-insurance or self-retention maintained by the Governments. Any insurance, self-insurance or self-retention maintained by the Governments shall be excess of the Contractor's insurance and the Subcontractor's insurance and shall not contribute with them. The insolvency or bankruptcy of the insured Subcontractor shall not release the insurer from payment under the policy, even when such insolvency or bankruptcy prevents the insured Subcontractor from meeting the retention limit under the policy. Any deductible amount or other obligations under the Subcontractor's policy(ies) shall be the sole responsibility of the Subcontractor. This insurance may be in policy or policies of insurance, primary and excess, including the so-called umbrella or catastrophe form and be placed with insurers rated "A-" or better by A.M. Best Company, Inc. The Governments will be indemnified, saved, and held harmless to the full extent of any coverage actually secured by the Subcontractor in excess of the minimum requirements set forth above. The Government Entity that hired the Subcontractor shall be held responsible for ensuring compliance with the above requirements by all Subcontractors. The Governments reserve the right to obtain complete, certified copies of all required insurance documents, policies, or endorsements at any time.

\*See *North Dakota Risk Management Manual*, section 5.1 for discussion of "unique" and "routine" agreements.

RM Consulted 2007  
Revised 5-09





30

October 10, 2018

Board of City Commissioners  
City Hall - 225 4<sup>th</sup> St N  
Fargo, ND 58102

Dear Commissioners:

The State of North Dakota has made \$2.5M available in grant funding made available for public transportation (transit). The grant opportunity is actually NDDOT re-issuing solicitations for remaining discretionary 5339 CDFA No. 20.526 funds (for bus and bus facilities by the Federal Transit Administration (FTA) and administered by the NDDOT) that were not awarded in the original applications solicited in the spring of 2018. The Transit Department is requesting funding a local share of \$400,000 (the federal share of the project is \$1,600,000).

This grant would have a profound impact on our community's transit system and the transportation options we offer our residents. There is a critical need for substantial renovations to the main transfer facility, the Ground Transportation Center (GTC). The GTC was built in 1984 and has had only one renovation in 2004 other than the bus deck overlays every 5-6 years. The useful life of the GTC as an asset is 40 years, which will be 2024 – currently making the facility 35 years old in need of updated HVAC, flooring inside and out, renovation of office and restroom spaces, lobby seating, relocation of the dispatch area, removal of the exterior canopy and replacement with a more functional covering, and several aesthetic repairs. In addition, developing a safer and more secure environment at the main transit transfer facility, the Ground Transportation Center (GTC), will enhance the comfort and feeling of security necessary to the riding public.

The Transit Development Plan identified the need to upgrade and rehab equipment, plus renovate/rehab/expand facilities to meet the demands of transit growth in the area especially as we migrate towards a regional transit authority.

A Facilities Study is substantially complete and demonstrates existing and projected conditions and identifies recommended renovations to the GTC in detail. The study will be completed by calendar year end 2018 at which time it will be brought before the City Commission for final approval. The application for is due October 19, 2018 for funding the renovation starting calendar year 2019.

The requested motion is to approve the attached grant application, and, upon successful receipt of funds, approve the grant execution. Thank you.

Sincerely,



Julie Bommelman  
City of Fargo Transit Director  
701-476-6737  
[jbommelman@cityoffargo.com](mailto:jbommelman@cityoffargo.com)

For Schedule Information: 701-232-7500



**FY 2019**  
**Mid-Year Application for**  
**Transit Funding**

Section 5339 Bus & Bus Facilities Grant Program	
Agency Name	City of Fargo
Agency Contact	<b>Julia Bommelman</b> Phone: 701.476.6737
DUNS #	070265871

Section 5339 – The Federal Transit Administration (FTA) Section 5339 (Bus & Bus Facilities Program) is a capital-only program and funds are limited to capital projects to replace, rehabilitate, and purchase buses and bus-related equipment, and to construct bus-related facilities.

NDDOT will use Section 5339 funds for vehicle purchases, bus related facility construction, including garages and transfer stations. Section 5339 funds can also be used for new technology, safety and security items for transit and vehicle rehabilitation. **The federal share of eligible project costs may not exceed 80% of the cost of the project.**

The entire Section 5339 – Bus and Bus Facilities Grants is further explained in FTA Circular 9300.1B, located on the FTA website at [https://www.transit.dot.gov/sites/fta.dot.gov/files/docs/Final\\_C\\_9300\\_1\\_Bpub.pdf](https://www.transit.dot.gov/sites/fta.dot.gov/files/docs/Final_C_9300_1_Bpub.pdf).

**Please Note:**

- Capital project requests will require a minimum of **20% Local Match**.
- Assets purchased with Federal Funds must be maintained and inventoried through the Transit Asset Management (TAM) Program.
- As with most Federal Assistance Programs, 5339 is designed as a reimbursement program. Your agency should be prepared to pay for your equipment upon delivery/acceptance and then request reimbursement from NDDOT.
- If requesting a replacement vehicle, the vehicle listed must have met FTA/NDDOT Useful Life. However, regardless of useful life having been met, federal interest remains until the value of the vehicle or equipment falls below \$5,000.
- If you receive \$750,000 from any federal source you are required to have a Single Audit per 2 CFR 200 subpart F.
- All applications are due **October 19, 2018, 12:00pm CDT**. Late and/or incomplete applications may be subject to a penalty percentage reduction of requested amount.

## GENERAL INFORMATION

1. Provide a detailed description of the transportation services your agency currently provides and any plans for increasing services, expanding service area and increasing ridership. (days and hours of service, fare structure, total vehicles in service, type of service being provided, transportation provided to what counties and communities in your service area, etc.).

The City of Fargo provides fixed route transportation services within Fargo and West Fargo, ND, and provides complimentary paratransit services within the entire metro area (the City of Moorhead contracts with the City of Fargo for para services). The ridership on fixed route doubled in 5 years to exceed 1.2M annually (Fargo and West Fargo only – Moorhead and Dilworth put us past 2M annually), paratransit is approximately 55,000 annually. The City of Fargo is the designated 5307 direct recipient of FTA grants in the area. There is a successful U-Pass and circulator program with North Dakota State University, coordination with several transportation providers in the area, and on-going efforts to evolve the agency and meet changing demands. Service was increased in July 2017 with the implementation of a new route to serve the expanding sw area of Fargo and West Fargo, including service to the new Sanford Hospital. There is a downtown circulator shared equally with the City of Moorhead designed to alleviate parking issues and encourage alternate means of transportation in the growing area of downtown.

Services include fixed route and paratransit – hours of operation are 6:15 am to 11:15 pm M-F and 7:15 am to 11:15 pm Saturday – there is no fixed route service on Sunday, however, paratransit operates 2 vehicles 7:00 am to 5:00 pm. The City of Moorhead implemented paratransit on Sundays effective July 2017. Fares on fixed route are \$1.50 for adults, \$.75 for seniors, people with disabilities, and youth; fares on paratransit are \$3.00. We currently have 29 fixed route vehicles and 15 paratransit vehicles for services – peak VOMS are 25 on fixed route and 14 on paratransit; the spare ratio is tight. We serve Cass County and, through our agreement with the City of Moorhead to provide paratransit, we also serve Clay County. With the growth of the Cities, the demand for transit has grown – the current Transit Development Plan identified a need for increased service hours, Sunday fixed route service, realignment of existing routes, and service to various expansion areas. The plan to increase ridership is a multi-faceted marketing approach to include social media, print, radio and community outreach and events, and implementing a downtown employer sponsored bus pass program. Several of these initiatives were implemented in 2017 and have carried forward to 2018.

2. Provide a detailed explanation of how and why this request is important to your agency and how it will improve or provide for future service to citizens in the communities/counties you provide service to. Explain where in your current 3-5 year plan this project(s) is specifically stated (list section and page number(s)).

These requests are vital to our agency. Updating the GTC will greatly enhance the presentability of the facility to passengers and offer an updated, user friendly experience. One of the goals of the renovation is to open up the facility to feel less closed off and bring more light and vibrancy in; we also want to update the seating, bathrooms, and several areas of the exterior. In addition, we plan to update the mechanical systems, roof, canopy, relocate dispatch and reconfigure the manner in which busses pull in and exit the GTC to improve safety and visibility.

There are approximately 3700 households that do not have access to an automobile, there are on-going efforts to reduce congestion in the metro area (transit is a logical alternative when 1 bus can take up to 50 cars off the roads), and the college population in the area grows to approximately 20,000 additional people in the metro area during the academic year, placing increased demands on roads/services. Transit contributes by providing public transportation for access to employment, medical, educational and other services for transit dependent and choice transit riders. As you are aware, the industry trend for the younger generations is focused more on quality of life and many members of that generation do not want to own a personal car and prefer transit.



The City of Fargo sincerely appreciates the opportunity to gain access to these capital funds for renovations at the GTC and the other miscellaneous support equipment. Existing FTA funds are currently being fully expended for operations and preventative maintenance, state aid is used for operations as well.

## VEHICLE PROJECT REQUESTS

**There is space provided below to request a replacement or expansion vehicle. If applying for more than one vehicle, please attach additional sheets and create a separate project for each vehicle in the Black Cat System.**

4. Description of the vehicle you are requesting. (include: Year, Make, ADA qualified, and seating capacity)

5. Describe in detail which programs and services the requested vehicle will be utilized in and how it will enhance or maintain your service?

6. If requesting a replacement, which vehicle in your fleet are you replacing?

- a. Vehicle Information Number (VIN):
- b. Vehicle Year:
- c. Make/Model:
- d. Current Mileage:

7. If requesting an expansion vehicle, list the agency/community/county to be served (include: hours and days of service and estimated ridership).

8. Provide an estimated timeline for the purchase of this vehicle (s). Provide a separate timeline if you are applying for different types of vehicles. **See sample timeline below, add or remove lines as needed.**

RFP/IFB Issue Date:

Contract Award Date:

Initial Vehicle Delivery Date:

Final Vehicle Deliver Date:

Contract Completion:

Final Payment Submitted to DOT:

9. Estimate the total cost of vehicle.

**Following are suggested price requests for vehicles based on current state bid quotes. Keep in mind if you intend to order vehicles with additional options prices will vary accordingly.**

ADA Low Floor Mini Van NDDOT Term Contract No. 382	Base price - \$37,995
14 Passenger or 12 + 2 Passenger Cutaway/Bus NDDOT Term Contract No. 384	Base price - \$58,759 - \$59,100

15 Passenger (including driver) Cutaway/Bus NDDOT Term Contract No. 300	Base price - \$69,995 - \$74,184
Rear Lift ADA Transit Vehicle NDDOT Term Contract No. 301	Base price - \$43,834 – 57,956
<b>FTA Useful Life Standards</b>	
Mini-Vans/Modified Vans – 3-14 passenger	4 years or 100,000 miles
Med-Size Light Duty Cutaway – 8-16 passenger	5 years or 150,000 miles
Med-Size Med Duty Cutaway/Bus – 16-30 passenger	7 years or 200,000 miles
Med-Size Heavy Duty Bus – 24-25 passenger	10 years or 350,000 miles
Large Heavy Duty Bus – 35-40+ passenger	12 years or 500,000 miles

## FACILITY PROJECT

**NOTE: This request MUST first be created as a project in the Black Cat System.**

### FACILITY REHABILITATION/RENOVATION PROJECT

10. Do you currently have a transit facility? If no, skip to the Construction Project section below.

Yes     No

11. If yes, briefly describe the facility, including the year it was constructed, and the need for rehabilitation, improvements or remodeling. Include information on the current building, year constructed, the number of vehicles your facility holds and any changes in your program that justify the request.

The facility requiring rehab is the Ground Transportation Center (GTC) which was constructed in 1984 and had one rehab in 2004 (bus deck overlays are done every 5-6 years). The GTC is the main transfer facility for the fixed route system and sales of fare media.

12. Give a detailed description of the proposed project. Include necessary repair work, cost estimates, temporary or permanent repair, and other details that you deem relevant to assist NDDOT in making a project determination.

The GTC is badly in need of many repairs and replacements such as portions of the HVAC system, bathrooms, flooring, exterior canopy, exterior pedestrian walkways, lighting, seating, and several other areas. In addition, the A facility study is substantially complete and identifies the areas of concern at the GTC. The study, performed by Kardamas, Lee & Jackson (KLJ) has more in-depth details and prioritizations. Upon final completion and adoption, a copy of the report will be furnished; for now, the draft information is current as of October 1, 2018 and outlines the status/conditions/recommendations (attached).

13. Provide an estimated timeline for the project (s). Provide a separate timeline for each project you are applying for. See sample timeline below, add or remove lines as needed.

RFP/IFB Issue Date: anticipate February 2019 depending upon funding

Contract Award Date: contract award would be approximately 45 days after the RFP/IFB is issued

Project State Date: approximately 30 days after award

Construction Completion Date: September/October 2019

Contract Completion: October/November 2019
Final Payment Submitted to DOT: December 2019
14. Has your Agency completed the FTA Region 8 Categorical Exclusion Worksheet for this project?
<input checked="" type="checkbox"/> Yes (Applicant must complete and attach the worksheet) <input type="checkbox"/> No (Applicant must provide an explanation)
15. Has your agency completed and attached an Equity Analysis for this renovation? NOTE: An Equity Analysis must occur before the preferred site is selected.
<input type="checkbox"/> Yes <input checked="" type="checkbox"/> No this project is to renovate an existing facility and the system operates under 50 buses at peak
16. Your agency will be <b>required</b> to interview and hire an architect/consultant to design the plans and specifications and manage the bidding and construction of this building to meet FTA and NDDOT standards and requirements. Have you incorporated these costs into your request?
<input checked="" type="checkbox"/> Yes <input type="checkbox"/> No
17. Have you completed an Independent Cost Estimate to show that the price is fair and reasonable? Provide this documentation.
<input checked="" type="checkbox"/> Yes <input type="checkbox"/> No
18. Are you proposing to use the value of land as match, in whole or part, for your project? If yes, please indicate whether this is an appraised value or estimate. Only the portion of land required for the project can be considered in this valuation.
<input type="checkbox"/> Yes <input checked="" type="checkbox"/> No <input type="checkbox"/> Appraised Value <input type="checkbox"/> Estimate Value
19. Does the appraised value or estimate cover your entire match? If not, identify other sources of match for this project.
<input type="checkbox"/> Yes <input checked="" type="checkbox"/> No local match will be provided by the City of Fargo from the general fund, fares, and advertising revenue
20. Has your agency held public meetings about this project? If yes, when and did the community support this project? Include documentation of all public meetings (agendas, advertisements, meeting minutes, comments, and list of attendees)
<input type="checkbox"/> Yes <input checked="" type="checkbox"/> No Public meetings are to be held late this year
21. Does your agency have a written Facility Maintenance Plan? Explain the procedures to ensure facility & equipment is inspected and maintained per manufacturer's warranty instructions on a regular scheduled basis as described in your Facility Maintenance and TAM Plans.
Yes, there is a current written Facility Maintenance Plan. The Fleet and Facilities Manager will oversee the facility in accordance with the outlined procedures identified within the plan, including all manufacturer specified maintenance. The Buildings & Grounds Department will assist the Fleet and Facilities Manager with oversight of the facility.
22. Are your facility and any maintenance records recorded in your TAM maintenance program as required by FTA and NDDOT? If No, please explain.
<input checked="" type="checkbox"/> Yes <input type="checkbox"/> No
23. What is the condition (1(Poor) – 5 (Excellent) rating scale assessment) rating of your facility?
The current condition of the GTC is Poor.



24. Estimate total project cost?

\$2,000,000

**PURCHASING A FACILITY**

Complete this portion if you propose to purchase an existing facility.

25. If purchasing a facility, what is the asking price?

26. Have you completed an Independent Cost Estimate to show that the price is fair and reasonable? Provide this documentation.

Yes  No

27. Justify why it is more cost effective to purchase this facility versus building a new one.

28. Describe the facility you are considering for purchase in detail. Provide specifications, environmental assessments, drawings/plans, etc.

29. Are there any known environmental issues with the facility you are proposing to purchase? (e.g. underground fuel storage) If yes, please describe.

Yes  No

30. Will this facility require any renovation for use in your transit program? If yes, please describe these renovations in detail and specify whether or not these costs are figured into the above asking price.

Yes  No

31. Has your agency held any public meetings about this project? If yes, when and did the community support this project? Include documentation of all public meetings (agendas, advertisements, meeting minutes, comments, and list of attendees)

Yes  No

32. Provide an estimated timeline for the project (s). Provide a separate timeline for each project you are applying for. NOTE: If renovations are needed you will need to add that to the timeline. See sample timeline below, add or remove lines as needed.

RFP/IFB Documents Date:

Purchase Date:

Project State Date:

Construction Completion Date:

Contract Completion:

Final Payment Submitted to DOT:

33. Estimate project cost including purchase and renovations.

**BUILDING A FACILITY**

Complete this portion if you propose to build a new facility.

34. Describe in detail the need for a facility in your transit program.
35. Describe your proposed project in detail. Include a description of all the amenities you feel the project will need to meet your needs – e.g. number of vehicles it will hold, wash bays, etc. Keep in mind, this facility should be designed to meet your current needs with a reasonable projection of your future needs.
36. Has your Agency completed the FTA Region 8 Categorical Exclusion Worksheet for this project? <input type="checkbox"/> Yes (Applicant must complete and attach the worksheet) <input type="checkbox"/> No (Applicant must provide an explanation)
37. Has your agency completed and attached an Equity Analysis for this renovation? NOTE: An Equity Analysis must occur before the preferred site is selected. <input type="checkbox"/> Yes <input type="checkbox"/> No
38. Do you have preliminary design plans for this project? If you do, please include a copy with this application. <input type="checkbox"/> Yes <input type="checkbox"/> No
39. Your agency will be <b>required</b> to interview and hire an architect/consultant to design the plans and specifications and manage the bidding and construction of this building to meet FTA and NDDOT standards and requirements. Have you incorporated these costs into your request?
40. Are you proposing to use the value of land as match, in whole or part, for your project? If yes, please indicate whether this is an appraised value or estimate. Only the portion of land required for the project can be considered in this valuation. <input type="checkbox"/> Yes <input type="checkbox"/> No <input type="checkbox"/> Appraised Value <input type="checkbox"/> Estimate Value
41. Does the appraised value or estimate cover your entire match? If not, identify other sources of match for this project. <input type="checkbox"/> Yes <input type="checkbox"/> No
42. Has your agency held any public meetings about this project? If yes, when and did the community support this project? Include documentation of all public meetings (agendas, advertisements, meeting minutes, comments, and list of attendees).
43. Have you looked at options to scale the building back in case the construction costs come in over budget?
44. Provide an estimated timeline for the project (s). Provide a separate timeline for each project you are applying for. <u><i>See sample timeline below, add or remove lines as needed.</i></u>
RFP/IFB Issue Date:
Contract Award Date:
Project State Date:



Construction Completion Date:
Contract Completion:
Final Payment Submitted to DOT:
45. Estimate total project cost?

**EQUIPMENT & MISCELLANEOUS CAPITAL PROJECTS**

Fill in the requested information below regarding your Equipment and Miscellaneous Capital Project(s). These projects must directly relate to your transportation program. Any equipment purchased with these funds must be required for, and used for, public transportation. **If applying for more than project, please attach additional sheets and create a separate project for each in the BlackCat System.**

46. Describe your proposed project(s) in detail (detail MUST include: type, quantity, cost, purpose of equipment being requested).
47. How does this project enhance your transportation program?
48. Have you completed an Independent Cost Estimate document to show that the price is fair and reasonable? Provide this documentation.
49. Provide an estimated timeline for the purchase of this equipment. Provide a separate timeline if you are applying for different types of equipment. <u><i>See sample timeline below, add or remove lines as needed.</i></u>
RFP/IFB Issue Date:
Contract Award Date:
Initial Delivery/Installation Date:
Final Deliver/Installation Date:
Contract Completion:
Final Payment Submitted to DOT:
50. Estimated cost for the project?

**FY 2019 PROJECT FUNDING REQUEST**

In the table below, list requested projects by priority, and specify in detail the sources and dollar amounts of Local Match funding (state aid, mill levy, donations, contract income, etc.) that are available to be used towards each project (Vehicle, Facility Rehabilitation & Construction, and/or Equipment/Miscellaneous Capital).

**\*Documentation of sources of Local Match (including state aid) MUST be attached or it will not be considered.**

Ranking	Project	Estimated Cost of Project	Local Match Needed	Sources of Local Match*
1	Rehab/Renovate GTC	\$2,000,000	\$400,000	General fund, fare revenue, advertising revenue
2				
3				
4				
5				

The NDDOT Transit Staff is available to provide guidance and answer any questions on the application process.

North Dakota Department of Transportation  
Local Government Division Transit Section  
608 East Boulevard Avenue  
Bismarck, ND 58505-0700

Phone: (701) 328-2542, 328-2835, 328-2194, or 328-3720,  
E-mail: [bhanson@nd.gov](mailto:bhanson@nd.gov), [dkarel@nd.gov](mailto:dkarel@nd.gov), [jsmall@nd.gov](mailto:jsmall@nd.gov) or [conelson@nd.gov](mailto:conelson@nd.gov) .

## FTA REGION 8 CATEGORICAL EXCLUSION WORKSHEET

This worksheet is provided to assist project sponsors (grantees) and FTA in complying with the National Environmental Policy Act (NEPA) for projects that may qualify as a Categorical Exclusion (CE) or a Documented Categorical Exclusion (DCE). It will help grantees gather information for environmental analysis, identify potential project impacts, and determine if other environmental laws and permits apply. It will also enable FTA to determine that the project does not result in significant environmental impacts and meets the criteria for a CE. This CE Worksheet should be completed for category C (c-list) CE projects involving construction and all category D (d-list) DCE projects.

All parts below must be completed prior to FTA review. If the project is a c-list CE and does not involve construction, you do not need to complete this worksheet. Compliance with other environmental requirements must also be completed before FTA will issue a determination that the project meets the criteria for a CE. Certain project activities may not begin until this process is complete. For guidance on completing this worksheet, please refer to the CE Worksheet Instructions.

If you need help or have any questions, contact Tracey MacDonald, the Region 8 Environmental Protection Specialist (EPS), at [tracey.macdonald@dot.gov](mailto:tracey.macdonald@dot.gov) or 303-362-2392. The completed CE Worksheet should be submitted to the Region 8 EPS with sufficient time for review, especially if other environmental laws or permits apply, prior to submitting a grant application.

### PART I: PROJECT INFORMATION

Project Sponsor <i>City of Fargo</i>	Date Submitted <i>10.3.18</i>	FTA Grant Number(s)/Funding Source(s) <i>5339</i>
Project Title <i>Renovation of the Ground Transportation Center (GTC) Facility and Bus Deck</i>		
Project Description and Location (include physical address) <i>The facility is located at 502 NP Ave, Fargo, ND 58102</i> <i>The categorical exclusion is C-8 Maintenance, Rehabilitation, Reconstruction of Facilities</i> <i>The facility is approximately 8200 square feet – the bus deck and main pedestrian areas are additional square footage. This project would initially maintain the same size/footprint of the existing facility. There are opportunities for bus deck expansion in the future that have been included in the current study.</i> <i>The facility and parcel are owned by the City of Fargo; the project is within parcel boundaries.</i> <i>The facility was originally constructed using federal and local funds. In addition, the facility was built over a parking garage, which was also funded with the same grant as the facility construction. Since the original project, FTA relinquished their interest in the parking garage portion of the facility.</i> <i>The project consists of renovation of the main transfer facility, the Ground Transportation Center (GTC), for the City of Fargo transit system. The GTC was constructed in 1984 and received one renovation in 2004. Currently, the GTC is badly in need of many repairs and replacements such portions of the HVAC system, bathrooms, flooring, exterior canopy, exterior pedestrian walkways, lighting, seating, the roof, the exterior bus deck and reconfiguration of interior offices/dispatch areas.</i>		

Project Contact (include mailing address, email address and phone number)  
*Julia Bommelman, Transit Director City of Fargo, 650 23<sup>rd</sup> St N, Fargo, ND 58102*  
 701.476.6737  
[jbommelman@fargond.gov](mailto:jbommelman@fargond.gov)

Is this project included in an approved TIP and/or STIP?  
 YES – TIP/STIP ID/Page No.:  NO – When will it be added? November 2018

Is this a re-evaluation of a project previously evaluated/approved or currently under construction?  
 NO  
 YES

**PART II: CATEGORICAL EXCLUSION DETERMINATION**

Please indicate which CE type under 23 CFR 771.118(c) or (d) best fits the proposed project (select only one). CE descriptions are included in the CE Worksheet Instructions.  
 CE (e.g., C-9 or D-6): C-8

**PART III: ENVIRONMENTAL EVALUATION**

This section is for the evaluation and identification of any adverse impacts to the built (including social and economic) and natural environment as a result of the project. For each item below, indicate if there are any adverse impacts and describe them. If a resource is not present on or in the vicinity of the proposed project, or if there are no adverse impacts, select NO. If a resource is present and impacted, select YES and succinctly describe the impacts and any necessary mitigation or permits required. The level of information provided should be consistent with the complexity of the project. For guidance on how to evaluate each resource for impacts, see the CE Worksheet Instructions. If your project will result in significant impacts or you aren't sure, and/or it is likely to generate substantial controversy, contact FTA Region 8.

**A. Land Use and Zoning Impacts**  
 Is the proposed project incompatible or inconsistent with existing or future land use and/or zoning in the project area?  
 NO  
 YES  
 A.1. Describe the surrounding land use and zoning.

<p><b>B. Traffic and Parking Impacts</b> Does the proposed project have the potential to permanently impact traffic and/or parking (on and off street) in the project area? Describe any temporary construction impacts in item T. Construction Impacts.</p> <p><input type="checkbox"/> NO <input checked="" type="checkbox"/> YES</p> <p><i>There is the potential for impacts to the bus driving entrance/exit to the facility. During the course of the study, the City Traffic Engineer has been consulted and is in agreement with the proposed changes – the street which will be impacted is being completely reconstructed by the City Engineering Department in 2019 or 2020 (dependent upon available funding) and will take into account this project.</i></p>
<p><b>C. Visual/Aesthetics Impacts</b> Are there any visual or aesthetic resources (e.g., protected view sheds or scenic vistas) or visual character in the vicinity of the proposed project that would be impacted?</p> <p><input checked="" type="checkbox"/> NO <input type="checkbox"/> YES</p>
<p><b>D. Farmland Impacts</b> Are there any prime or unique farmlands located at the proposed project site that would be impacted?</p> <p><input checked="" type="checkbox"/> NO <input type="checkbox"/> YES</p>
<p><b>E. Environmental Justice Impacts</b> Is the proposed project located within a neighborhood containing minority or low-income residents or businesses? If yes, will it result in disproportionately high and adverse impacts?</p> <p><input checked="" type="checkbox"/> NO <input type="checkbox"/> YES</p>
<p><b>F. Floodplain Impacts</b> Is the proposed project located within the Federal Emergency Management Agency (FEMA) 100-year floodplain or within the floodway? If yes, this project may require further evaluation under EO 11988.</p> <p><input checked="" type="checkbox"/> NO <input type="checkbox"/> YES</p>

**G. Air Quality Impacts**

Is the proposed project located in an Environmental Protection Agency (EPA)-designated non-attainment or maintenance area?

NO

YES, indicate the criteria pollutant and contact FTA to determine if a hot spot analysis is necessary.

- Carbon Monoxide (CO)
- Sulfur Dioxide (SO<sub>2</sub>)
- Lead (Pb)
- Nitrogen Dioxide (NO<sub>2</sub>)
- Ozone (O<sub>3</sub>)
- Particulate Matter (PM<sub>10</sub>)
- Particulate Matter (PM<sub>2.5</sub>)

G.1. Does the proposed project require a conformity analysis or regional analysis under 40 CFR Part 93?

NO

YES

G.2. If the non-attainment area is also in a metropolitan area, was the proposed project required to be and included in the MPO's air quality conformity analysis for the Transportation Improvement Program (TIP)?

NO

YES, date of USDOT conformity finding

**H. Hazardous Materials Impacts**

Is there any known or potential contamination at the proposed project site that would be impacted? Explain how this was determined.

NO

YES

**I. Vibration Impacts**

Are there any vibration sensitive receptors located in the vicinity of the proposed project that would be impacted?

NO

YES

**J. Noise Impacts**

Are there any noise sensitive receptors located in the vicinity of the proposed project that would be impacted?

NO

YES

**K. Water Quality Impacts**

Are there any surface or ground water resources present, including an EPA-designated sole source aquifer (SSA), in the vicinity of the proposed project that would be impacted?

- NO
- YES

K.1 Is there an increase in impervious surface (e.g., roofs, driveways, streets, parking lots, etc.) or restored pervious surface as a result of the proposed project?

- NO
- YES

**L. Land/Property Acquisition, Relocation, Leases and Easements**

Does the proposed project require any acquisition of land/property or any easements? Note: for acquisitions over \$500,000, FTA concurrence with the property's valuation is also required.

- NO
- YES

**M. Wetland Impacts**

Are there any wetlands on or adjacent to the proposed project that would be temporarily or permanently impacted?

- NO
- YES

If YES, is a permit from the US Army Corps of Engineers required?

- NO
- YES

**N. Natural Resource Impacts**

Are there any natural areas present on or near the proposed project that would be impacted? If the proposed project has the potential to impact wildlife or waterfowl refuges, a Section 4(f) evaluation may be required.

- NO
- YES

If YES, does Section 4(f) apply?

- NO, explain
- YES

**O. Historic, Cultural and Archaeological Resource Impacts**

Are there any historic, cultural or archaeological resources on or near the proposed project site? If yes and the proposed project has the potential to affect such resources, the Section 106 process must be followed and a Section 4(f) evaluation may be required.

NO

YES

If YES resources are present, does Section 106 apply?

NO, explain

YES

If YES resources are present, does Section 4(f) apply?

NO, explain

YES

**P. Biological Resource Impacts**

Are there any biological resources or sensitive areas on or in the vicinity of the proposed project that would be impacted?

NO

YES

**Q. Threatened and/or Endangered Species Impacts**

Are there any threatened and/or endangered species (plant or animal) or critical habitat present on or in the vicinity of the proposed project that would be impacted? If yes, Section 7 of the Endangered Species Act may apply.

NO

YES

**R. Recreation and Park Resource Impacts**

Are there any recreation areas and/or public parks on or adjacent to the proposed project that would be impacted? If the proposed project has the potential to impact recreation areas or publicly-owned parks, a Section 4(f) evaluation may be required. If a park is funded with LWCF funds, Section 6(f) may apply.

NO

YES

If YES, does Section 4(f) apply?

NO

YES

If yes, does Section 6(f) apply?

NO

YES



<p><b>S. Safety and Security</b> Are any measures required for the safe and secure operation of the proposed project after its construction?</p> <p><input type="checkbox"/> NO <input checked="" type="checkbox"/> YES</p> <p><i>Following the project, there will be improved safety for pedestrians by adding barriers (such as fencing) to force pedestrian traffic on pathways away from bus driving lanes, improved access to restrooms and dispatch area for customer service, additional cameras and signage will be added for increased safety and security, upgrades in lighting as well as additional adding lighting to better illuminate certain areas currently needing improvements.</i></p>
<p><b>T. Construction Impacts</b> Will the proposed project result in impacts during construction?</p> <p><input type="checkbox"/> NO <input checked="" type="checkbox"/> YES</p> <p><i>It is anticipated the project will likely take approximately 3-4 months; impacts will include noise, brief utility disruption, debris dust and staging areas. There will not be any air or water quality impacts, safety and security during the project will be minimal, access to the property will not be impacted.</i></p> <p><i>Mitigation of construction impacts will be minimized by performing the project incrementally as to allow the lowest possible impacts. During the previous renovation, safety fencing was put up to separate pedestrian and bus traffic from the construction areas – caution tape and cones were also utilized. As much as possible, the more impactful portions of the project (utility disruption) will be done on Sundays as the facility is closed to the public and there is no transit service on Sundays.</i></p>
<p><b>U. Utility Impacts</b> Are there any utilities that could be impacted by the proposed project?</p> <p><input type="checkbox"/> NO <input checked="" type="checkbox"/> YES</p> <p>Any disruption of utilities would be minimal and performed either during off peak times or on Sundays.</p>
<p><b>V. Cumulative and Indirect Impacts</b> Are adverse cumulative and/or indirect impacts likely?</p> <p><input checked="" type="checkbox"/> NO <input type="checkbox"/> YES</p>
<p><b>W. Public Outreach and Agency Coordination</b> Was any public outreach and/or agency coordination conducted?</p> <p><input type="checkbox"/> NO <input checked="" type="checkbox"/> YES</p> <p><i>This project is being done with guidance from an in-depth study which will include public outreach. The study will be complete by early 2019, public outreach (open forums, written input, legal notifications, website notifications) will be prior to finalizing the project.</i></p>

**X. State and Local Permits, Policies and Ordinances**

Does the proposed project require compliance with any applicable state and local permits, policies and ordinances?

NO

YES

*Construction permits issued by the City of Fargo will be required – these will be secured prior to the start of any project.*

**SUBMITTED BY (NAME AND TITLE):**

**DATE:**

*Julia Bommelman  
Transit Director, City of Fargo*

*10.3.18*

PUBLIC WORKS PROJECTS EVALUATION COMMITTEE

31

Project No. FM-14-63 Type: Negative Final Balancing Change Order #3

Location: Drain 27 – Prairie Rose Addition Date of Hearing: 10/1/2018

<u>Routing</u>	<u>Date</u>
City Commission	10/8/2018
PWPEC File	X
Project File	Roger Kluck

The Committee reviewed the accompanying correspondence from Project Manager, Roger Kluck, for Negative Final Balancing Change Order #3 in the amount of \$-21,266.18, bringing the total contract amount to \$243,035.40.

Staff is recommending approval of Negative Final Balancing Change Order #3.

On a motion by Bruce Grubb, seconded by Brenda Derrig, the Committee voted to recommend approval of Negative Final Balancing Change Order #3.

RECOMMENDED MOTION

Approve Negative Final Balancing Change Order #3 in the amount of \$-21,266.18 to Excavating, Inc.

PROJECT FINANCING INFORMATION:

Recommended source of funding for project: Flood Sales Tax

	<u>Yes</u>	<u>No</u>
Developer meets City policy for payment of delinquent specials		N/A
Agreement for payment of specials required of developer		N/A
Letter of Credit required (per policy approved 5-28-13)		N/A

COMMITTEE

	<u>Present</u>	<u>Yes</u>	<u>No</u>	<u>Unanimous</u>
				<input checked="" type="checkbox"/>
Tim Mahoney, Mayor	<input checked="" type="checkbox"/>	<input checked="" type="checkbox"/>	<input type="checkbox"/>	
Nicole Crutchfield, Director of Planning	<input checked="" type="checkbox"/>	<input checked="" type="checkbox"/>	<input type="checkbox"/>	
Steve Dirksen, Fire Chief	<input checked="" type="checkbox"/>	<input checked="" type="checkbox"/>	<input type="checkbox"/>	
Bruce Grubb, City Administrator	<input checked="" type="checkbox"/>	<input checked="" type="checkbox"/>	<input type="checkbox"/>	
Ben Dow, Director of Operations	<input checked="" type="checkbox"/>	<input checked="" type="checkbox"/>	<input type="checkbox"/>	
Steve Sprague, City Auditor	<input checked="" type="checkbox"/>	<input checked="" type="checkbox"/>	<input type="checkbox"/>	
Brenda Derrig, City Engineer	<input checked="" type="checkbox"/>	<input checked="" type="checkbox"/>	<input type="checkbox"/>	
Kent Costin, Finance Director	<input checked="" type="checkbox"/>	<input checked="" type="checkbox"/>	<input type="checkbox"/>	

ATTEST:

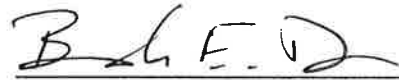
  
 Brenda E. Derrig, P.E.  
 City Engineer

C: Kristi Olson



# Memorandum

**To:** Members of PWPEC  
**From:** Roger E. Kluck, PE, CFM, Engineer II  
**Date:** September 26, 2018  
**Re:** Project #FM-14-63 Drain 27-Prairie Rose Flood Risk Management Project-Phase 3  
Final Balancing Change Order #3

**Background:**

Project FM-14-63 Drain 27-Prairie Rose Flood Risk Management Project-Phase 3 was developed to complete flood control on the south side of Drain 27 from I29 to 40<sup>th</sup> Avenue South for this area.

Attached is the Final Balancing Change Order #3, for -\$21,266.18. The Contractor met the requirements of the contract and it has been accepted by the City. This FBCO reconciles the estimated quantities used in the contract with the final quantities as measured in the field.

Original Contract:	\$	261,671.58
Change Order #1	\$	0.00 (Time extension)
Change Order #2	\$	2,630.00
FBCO #3:	\$	-21,266.18
Total Contract:	\$	243,035.40

The "Flood Sales Tax" funded all costs.

**Recommended Motion:**

Approve the Final Balancing Change Order #3 to Excavating, Inc. for -\$21,266.18.

REK/klo  
Attachment

C: Tom Knakmuhs



**CITY OF FARGO  
ENGINEERING DEPARTMENT  
CHANGE ORDER REPORT**

Paving	33	F&I Asphalt Cement PG 58-28	GAL	2,373.00	0.00	2,373.00	605.00	2,978.00	1.85	1,119.25
Flood Mitigation	36	Topsoil - Strip	CY	5,270.00	0.00	5,270.00	-2,744.00	2,526.00	2.50	7,180.30
	37	Topsoil - Spread	CY	3,471.00	0.00	3,471.00	-490.00	2,981.00	2.50	-1,225.00
	38	Topsoil - Import	CY	500.00	0.00	500.00	200.00	700.00	8.50	1,700.00
	39	Fill - Import	CY	5,004.00	0.00	5,004.00	-1,863.00	3,141.00	6.90	-12,854.70
	40	Fill - Haul	CY	1,799.00	0.00	1,799.00	-1,049.00	750.00	4.10	-4,300.90
	41	Embankment	CY	7,509.00	0.00	7,509.00	-840.00	6,669.00	3.00	-2,520.00
	42	Excavation	CY	2,505.00	0.00	2,505.00	1,773.00	4,278.00	2.80	4,964.40
	43	Subcut	CY	500.00	0.00	500.00	-437.00	63.00	3.10	-1,354.70
	44	Mulching Type 1 - Hydro	SY	26,585.00	0.00	26,585.00	-10,354.00	16,231.00	0.32	-3,313.28
	45	Seeding Type B	SY	26,585.00	0.00	26,585.00	-2,575.00	24,010.00	0.30	-772.50
	46	Overseeding	SY	26,585.00	0.00	26,585.00	-17,873.00	8,712.00	0.06	-1,072.38
	47	Weed Control Type B	SY	26,585.00	0.00	26,585.00	-26,585.00	0.00	0.06	-1,595.10
	48	F&I Erosion Control Blanket Type 3	SY	6,749.00	0.00	6,749.00	1,029.00	7,778.00	1.32	1,358.28
									<b>Flood Mitigation Sub Total (\$)</b>	<b>-27,845.88</b>

**Summary**

**Source Of Funding**

**Net Amount Change Order # 3 (\$)**

**Previous Change Orders (\$)**

**Original Contract Amount (\$)**

**Total Contract Amount (\$)**

-21,266.18  
2,630.00  
281,671.58  
243,035.40

I hereby accept this order both as to work to be performed and prices on which payment shall be based.

**CONTRACT TIME**

**Current Substantial Completion Date**  
07/01/2018

**Current Final Completion Date**  
0.00

**Additional Days Substantial Completion**  
0.00

**Additional Days Final Completion**  
0.00

**New Substantial Completion Date**  
07/01/2018

**New Final Completion Date**



CITY OF FARGO  
ENGINEERING DEPARTMENT  
CHANGE ORDER REPORT

Description

APPROVED

For Contractor 

Title Estimator/PM

APPROVED DATE

Department Head  10/4/18

Mayor

Attest

PUBLIC WORKS PROJECTS EVALUATION COMMITTEE

32

Project No. FM-15-F2

Type: Change Order #2 & Time Extension

Location: River Dr, Hackberry Dr & Harwood Dr

Date of Hearing: 10/1/2018

<u>Routing</u>	<u>Date</u>
City Commission	10/8/2018
PWPEC File	X
Project File	Rob Hasey

The Committee reviewed the accompanying correspondence from Project Manager, Rob Hasey, regarding a change order and time extension for Industrial Builders due to additional work totaling \$13,245. The time extension is for the Interim Completion Date. The Contractor is asking for 13 days to accommodate the move of 726 Hackberry Dr S.

Staff is recommending approval of the change order and time extension.

On a motion by Bruce Grubb, seconded by Brenda Derrig, the Committee voted to recommend approval of Change Order #2 in the amount of \$13,245.00 and a 13-day time extension to the Interim Completion Date.

RECOMMENDED MOTION

Approve Change Order #2 in the amount of \$13,245.00 to Industrial Builders and time extension for the Interim Completion Date.

PROJECT FINANCING INFORMATION:

Recommended source of funding for project:	Yes	No
Flood Sales Tax		
Developer meets City policy for payment of delinquent specials	N/A	
Agreement for payment of specials required of developer	N/A	
Letter of Credit required (per policy approved 5-28-13)	N/A	

COMMITTEE

	Present	Yes	No	Unanimous
				<input checked="" type="checkbox"/>
Tim Mahoney, Mayor	<input checked="" type="checkbox"/>	<input checked="" type="checkbox"/>	<input type="checkbox"/>	
Nicole Crutchfield, Director of Planning	<input checked="" type="checkbox"/>	<input checked="" type="checkbox"/>	<input type="checkbox"/>	
Steve Dirksen, Fire Chief	<input checked="" type="checkbox"/>	<input checked="" type="checkbox"/>	<input type="checkbox"/>	
Bruce Grubb, City Administrator	<input checked="" type="checkbox"/>	<input checked="" type="checkbox"/>	<input type="checkbox"/>	
Ben Dow, Director of Operations	<input checked="" type="checkbox"/>	<input checked="" type="checkbox"/>	<input type="checkbox"/>	
Steve Sprague, City Auditor	<input checked="" type="checkbox"/>	<input checked="" type="checkbox"/>	<input type="checkbox"/>	
Brenda Derrig, City Engineer	<input checked="" type="checkbox"/>	<input checked="" type="checkbox"/>	<input type="checkbox"/>	
Kent Costin, Finance Director	<input checked="" type="checkbox"/>	<input checked="" type="checkbox"/>	<input type="checkbox"/>	

ATTEST:

C: Kristi Olson

  
Brenda E. Derrig, P.E.  
City Engineer



ENGINEERING DEPARTMENT  
225 4<sup>th</sup> Street North  
Fargo, North Dakota 58102  
Phone: (701) 241-1545  
Fax: (701) 241-8101  
E-Mail: Feng@FargoND.gov

# Memorandum

**To:** PWPEC  
**From:** Rob Hasey, Civil Engineer I, Storm Sewer Utility  
**C:** Jody Bertrand, Division Engineer  
**Date:** 10/01/2018  
**Re:** Project #FM-15-F2 – Change Order #2 & Interim Completion Date Time Extension Request

**Background:**

Project FM-15-F2 was bid on June 27, 2018 and was awarded to Industrial Builders, Inc. This project is phase 2 of the River Drive, Hackberry Drive and Harwood Drive flood protection project that removes 5 residential structures and constructs earthen levees that tie into the levees that were previously constructed on phase 1.

The attached Change Order #2 is to adjust bid quantities due to varying conditions in the field when terminating sewer and water services to the five houses that were removed. One item in particular, extra class 3 gravel backfill was needed due to inaccuracies in the service tie cards for the property at 3908 River Drive. The Contractor needed to excavate more in the road to locate these services and therefore needed more class 3 gravel backfill.

Industrial Builders is also requesting an additional 13 days to accommodate the move of 726 Hackberry Drive South. The Contractor was directed to have all five houses on the project removed by the interim completion date of September 21<sup>st</sup>. Two houses have been moved from the project, two were demolished and 726 Hackberry Drive South is scheduled to be moved. A delay with Ottertail Power Company is delaying the move of this structure until October 1<sup>st</sup>, 2018. The Contractor is asking for a few extra days until October 4<sup>th</sup> to account for potential weather delays. The foundation that 726 Hackberry Drive sat upon has been removed and the house has been moved to the west to allow continuation of the levee construction along Hackberry Drive. I am in favor of granting the extra days needed to move this structure due to delays caused by Ottertail Power Company. Having the house sit to the side is not detrimental to the progress of the project. Substantial and final completion dates for the project will remain unaffected with this request.

Attached to this memorandum is Change Order #2 totaling \$13,245 for the additional quantities associated with pavement removal & replacement and for extra class 3 gravel backfill for service terminations. Recommended source of funding is Sales Tax Funds – Flood Control - 460.

**Recommended Motion:**

Approve Change Order #2 as shown:

Original Contract Amount	Previous Change Orders	Change Order #2	New Contract Amount
\$806,698.90	\$21,016.00	\$13,245.00	\$840,959.90

*Street Lighting  
Sidewalks*

*Design & Construction  
Traffic Engineering*

*Truck Regulatory  
Flood Plain Mgmt.*

*Mapping & GIS  
Utility Locations*





**CITY OF FARGO  
ENGINEERING DEPARTMENT  
CHANGE ORDER REPORT**

**Project No** FM-15-F2 **Change Order No** 2  
**Project Name** Flood Risk Management  
**Date Entered** 9/19/2018 **For** Industrial Builders Inc

This change is made under the terms of or is supplemental to your present contract , if and when approved, you are ordered to perform the work in accordance with the additions, changes, or alterations hereinafter described.

**EXPLANATION OF CHANGE:**

Section	Line No	Item Description	Unit	Orig Cont Qty	Prev C/O Qty	Prev Cont Qty	Curr C/O Qty	Tot Cont Qty	Unit Price (\$)	C/O Ext Price (\$)
Miscellaneous	5	Remove Tree	EA	132.00	0.00	132.00	10.00	142.00	250.00	2,500.00
<b>Paving</b>								<b>Miscellaneous Sub Total (\$)</b>		<b>2,500.00</b>
	33	Remove Pavement All Thicknesses All Types	SY	643.00	100.00	743.00	7.00	750.00	12.00	84.00
	34	Subgrade Preparation	SY	808.00	138.00	946.00	55.00	1,001.00	3.00	165.00
	35	F&I Woven Geotextile	SY	808.00	138.00	946.00	55.00	1,001.00	2.00	110.00
	36	F&I Class 5 Agg - 8" Thick	SY	808.00	138.00	946.00	55.00	1,001.00	12.00	660.00
	37	F&I Curb & Gutter Mountable (Type 1)	LF	555.00	91.00	646.00	42.00	688.00	55.00	2,310.00
	38	Remove Curb & Gutter	LF	559.00	91.00	650.00	38.00	688.00	5.00	190.00
	46	F&I Aggregate for Asph Pavement FAA 43	TON	230.00	40.00	270.00	59.00	329.00	58.00	3,422.00
	47	F&I Asphalt Cement PG 58-28	GAL	3,315.00	575.00	3,890.00	345.00	4,235.00	3.20	1,104.00
	50	* Class 3 gravel backfill	LS	0.00	0.00	0.00	1.00	1.00	2,700.00	2,700.00
								<b>Paving Sub Total (\$)</b>		<b>10,745.00</b>
								<b>Grand Total (\$)</b>		<b>13,245.00</b>

\* NC Items

**Summary**

**Source Of Funding** Sales Tax Funds - Flood Control - 460

**Net Amount Change Order # 2 (\$)** 13,245.00



CITY OF FARGO  
ENGINEERING DEPARTMENT  
CHANGE ORDER REPORT

Previous Change Orders (\$)	21,016.00
Original Contract Amount (\$)	806,698.90
Total Contract Amount (\$)	840,959.90

I hereby accept this order both as to work to be performed and prices on which payment shall be based.

**CONTRACT TIME**

Current Substantial Completion Date	Current Final Completion Date	Additional Days Substantial Completion	Additional Days Final Completion	New Substantial Completion Date	New Final Completion Date
10/01/2018	10/01/2018	0.00	0.00	10/01/2018	10/01/2018

**Description**

**APPROVED**

*Erik Diederich*

For Contractor  
Industrial Builders, Inc.

**Title**

Director of Business Development

**APPROVED DATE**

Department Head

*[Signature]* 10/4/18

Mayor

Attest

# MEMO



## 6059-072 – Harwood, Hackberry, River Drive Levees, Phase 2

**To:** Rob Hasey – City of Fargo

**From:** Bjorn Berg

**Date:** September 19, 2018

**Subject:** Change Order No. 2 – FM-15-F2

This memo serves as our recommendation to process Change Order No. 2 for Project FM-15-F2 Harwood, Hackberry, River Drive Levees Flood Risk Management Project (Phase 2). This Change Order addresses the additional roadway that was required to be removed and replaced through-out the project extents, as well as the additional class 3 backfill used to backfill the roadway when it was discovered the original tie card was incorrect for 3908 River Drive South.

The total Change Order amount is an increase of \$13,245.00 which is an increase of 1.60% over the current contract amount with Change Order No. 1.

Attached is the cost justification for the additional class 3 backfill, as well as the updated quantities that are being adjusted with this Change Order.

FF:\Fargo\EN\6059-072\Task 2\Civil\Info\Req\Change Order\Change Order No 2\20180918-Propd\Memo-Rob Hasey-6059072-River Drive PH2-Change Order No 2.doc

**Harwood, Hackberry, River Drive Levees Phase 2**  
 City of Fargo Project Number FM-15-F2  
 HEI Proj. No. 6059-072

Change Order No. 2

COF ITEM	Line	Description	Quantity	Unit	Current Contract Through Change Order No. 1		CO No. 2 Quantity Change	Change Order No. 2 9/21/2018			
					Unit Price	Total		Total Quantity	CO No. 2 Cost Change	Total	
	<b>MISCELLANEOUS</b>										
1	0000-0028-0ABAT	Abatement - Asbestos Cement	4	EA	\$ 10,000.00	\$ 40,000.00	0	4	\$ -	\$ 40,000.00	
2	0000-1010-00000	Mobilization	1	LS	\$ 43,300.00	\$ 43,300.00	0	1	\$ -	\$ 43,300.00	
3	0000-F150-0SAFE	Temp Fence - Safety	990	LF	\$ 3.50	\$ 3,465.00	0	990	\$ -	\$ 3,465.00	
4	1050-A010-00000	Clear & Grub	1	LS	\$ 8,000.00	\$ 8,000.00	0	1	\$ -	\$ 8,000.00	
5	1050-BR20-00000	Remove Tree	132	EA	\$ 250.00	\$ 33,000.00	10	142	\$ 2,500.00	\$ 35,500.00	
6	1500-ZE70-00000	Repair Concrete	87	SY	\$ 135.00	\$ 11,745.00	0	87	\$ -	\$ 11,745.00	
7	3300-3020-00000	Temp Construction Entrance	8	EA	\$ 1,500.00	\$ 12,000.00	0	8	\$ -	\$ 12,000.00	
8	3300-F050-05C12	Silt Fence - Standard	3,300	LF	\$ 1.60	\$ 5,280.00	0	3,300	\$ -	\$ 5,280.00	
9	3300-G050-DB082	Sediment Control Log 6" to 8" Dia	3,407	LF	\$ 2.10	\$ 7,154.70	0	3,407	\$ -	\$ 7,154.70	
10	3300-P020-05COE	Inlet Protection - Existing Inlet	26	EA	\$ 160.00	\$ 4,160.00	0	26	\$ -	\$ 4,160.00	
11	3500-FR21-00000	Remove Foundation All Types	5	EA	\$ 23,000.00	\$ 115,000.00	0	5	\$ -	\$ 115,000.00	
12	3500-D020-00000	Demolition	5	EA	\$ 1,000.00	\$ 5,000.00	0	5	\$ -	\$ 5,000.00	
		<b>MISCELLANEOUS SUB TOTAL</b>				<b>\$ 288,104.70</b>				<b>\$ 290,604.70</b>	
	<b>FLOOD MITIGATION</b>										
13	2000-AD90-00000	Topsoil Strip	3,703	CY	\$ 2.00	\$ 7,406.00	0	3,703	\$ -	\$ 7,406.00	
14	2000-B090-00000	Topsoil Spread	3,703	CY	\$ 3.00	\$ 11,109.00	0	3,703	\$ -	\$ 11,109.00	
15	2000-D090-00000	Topsoil Import	2,986	CY	\$ 6.00	\$ 17,916.00	0	2,986	\$ -	\$ 17,916.00	
16	2000-J090-00000	Fill - Import	14,868	CY	\$ 10.00	\$ 148,680.00	0	14,868	\$ -	\$ 148,680.00	
17	2000-L090-00000	Fill - Haul	500	CY	\$ 6.00	\$ 3,000.00	0	500	\$ -	\$ 3,000.00	
18	2000-N090-00000	Embankment	8,331	CY	\$ 3.00	\$ 24,993.00	0	8,331	\$ -	\$ 24,993.00	
19	2000-X090-00000	Excavation	8,331	CY	\$ 2.00	\$ 16,662.00	0	8,331	\$ -	\$ 16,662.00	
20	2000-Y090-00000	Subcut	500	CY	\$ 5.00	\$ 2,500.00	0	500	\$ -	\$ 2,500.00	
21	3100-M070-X0001	Mulching Type 1 - Hydro	52,756	SY	\$ 0.35	\$ 18,464.60	0	52,756	\$ -	\$ 18,464.60	
22	3100-S070-X000B	Seeding Type B	52,756	SY	\$ 0.30	\$ 15,826.80	0	52,756	\$ -	\$ 15,826.80	
23	3100-T070-00000	Overs seeding	52,756	SY	\$ 0.15	\$ 7,913.40	0	52,756	\$ -	\$ 7,913.40	
24	3100-W070-X000B	Weed Control Type B	52,756	SY	\$ 0.10	\$ 5,275.60	0	52,756	\$ -	\$ 5,275.60	
25	3300-EN70-X0003	F&I Erosion Control Blanket Type 3	18,982	SY	\$ 1.40	\$ 26,574.80	0	18,982	\$ -	\$ 26,574.80	
26	3600-I090-00000	Inspection Trench	17,594	CY	\$ 3.00	\$ 52,782.00	0	17,594	\$ -	\$ 52,782.00	
		<b>FLOOD MITIGATION SUB TOTAL</b>				<b>\$ 359,103.20</b>				<b>\$ 359,103.20</b>	
	<b>SANITARY SEWER</b>										
27	2400-H020-00000	Casting to Grade - no Conc	1	EA	\$ 500.00	\$ 500.00	0	1	\$ -	\$ 500.00	
28	1400-AY20-00000	Eliminate Sewer Service	6	EA	\$ 2,500.00	\$ 15,000.00	0	6	\$ -	\$ 15,000.00	
		<b>SANITARY SEWER SUB TOTAL</b>				<b>\$ 15,500.00</b>				<b>\$ 15,500.00</b>	
	<b>WATERMAIN</b>										
29	1400-SY20-00000	Eliminate Water Service	6	EA	\$ 2,500.00	\$ 15,000.00	0	6	\$ -	\$ 15,000.00	
30	2400-J020-00000	GV Box to Grade - Blvd	1	EA	\$ 500.00	\$ 500.00	0	1	\$ -	\$ 500.00	
		<b>WATERMAIN SUB TOTAL</b>				<b>\$ 15,500.00</b>				<b>\$ 15,500.00</b>	
	<b>STORM SEWER</b>										
31	1500-PR51-00001	Remove Pipe All Sizes All Types	114	LF	\$ 6.00	\$ 684.00	0	114	\$ -	\$ 684.00	
32	2400-H020-00000	Casting to Grade - no Conc	1	EA	\$ 500.00	\$ 500.00	0	1	\$ -	\$ 500.00	
		<b>STORM SEWER SUB TOTAL</b>				<b>\$ 1,184.00</b>				<b>\$ 1,184.00</b>	
	<b>PAVING</b>										
33	1050-PR71-00002	Remove Pavement All Thicknesses All Types	743	SY	\$ 12.00	\$ 8,916.00	7	750	\$ 84.00	\$ 9,000.00	
34	2000-Z070-00000	Subgrade Preparation	946	SY	\$ 3.00	\$ 2,838.00	55	1001	\$ 165.00	\$ 3,003.00	
35	2050-WN7G-00000	F&I Woven Geotextile	946	SY	\$ 2.00	\$ 1,892.00	55	1001	\$ 110.00	\$ 2,002.00	
36	2070-SN70-K0080	F&I Class 5 Agg - 8" Thick	946	SY	\$ 12.00	\$ 11,352.00	55	1001	\$ 660.00	\$ 12,012.00	
37	2100-RN50-X001M	F&I Curb & Gutter Mountable (Type I)	646	LF	\$ 55.00	\$ 35,530.00	42	688	\$ 2,310.00	\$ 37,840.00	
38	2100-RR50-00000	Remove Curb & Gutter	650	LF	\$ 5.00	\$ 3,250.00	38	688	\$ 190.00	\$ 3,440.00	
39	2300-AN7C-K0040	F&I Sidewalk 4" Thick Reinf Conc	327	SY	\$ 90.00	\$ 29,430.00		327	\$ -	\$ 29,430.00	
40	2300-AN7C-K0060	F&I Sidewalk 6" Thick Reinf Conc	16	SY	\$ 95.00	\$ 1,520.00		16	\$ -	\$ 1,520.00	
41	2300-AR71-00002	Remove Sidewalk All Thicknesses All Types	219	SY	\$ 5.00	\$ 1,095.00		219	\$ -	\$ 1,095.00	
42	2300-CN7C-K0040	F&I Impressioned 4" Thick Reinf Conc	25	SY	\$ 200.00	\$ 5,000.00		25	\$ -	\$ 5,000.00	
43	2300-DN7C-K0070	F&I Driveway 7" Thick Reinf Conc	44	SY	\$ 95.00	\$ 4,180.00		44	\$ -	\$ 4,180.00	
44	2300-DR71-00002	Remove Driveway All Thicknesses All Types	2054	SY	\$ 4.00	\$ 8,216.00		2054	\$ -	\$ 8,216.00	
45	2300-WN60-00000	F&I Det Warn Panels Cast Iron	27	SF	\$ 48.00	\$ 1,296.00		27	\$ -	\$ 1,296.00	
46	2400-AN40-P0043	F&I Aggregate for Asph Pavement FAA 43	270	Ton	\$ 58.00	\$ 15,660.00	59	329	\$ 3,422.00	\$ 19,082.00	
47	2400-RN00-P582B	F&I Asphalt Cement PG 58-28	3890	Gal	\$ 3.20	\$ 12,448.00	345	4235	\$ 1,104.00	\$ 13,552.00	
48	3300-S020-00000	Concrete Washout Area	1	EA	\$ 700.00	\$ 700.00		1	\$ -	\$ 700.00	
49	4100-0010-XT001	Traffic Control - Type 1	1	LS	\$ 5,000.00	\$ 5,000.00	0	1	\$ -	\$ 5,000.00	
		Extra - Class 3 Backfill	0	LS	\$ 2,700.00	\$ -	1	1	\$ 2,700.00	\$ 2,700.00	
		<b>PAVING SUB TOTAL</b>				<b>\$ 148,323.00</b>				<b>\$ 159,068.00</b>	
		<b>Contract Amount Through Change Order No. 1</b>				<b>\$ 827,714.90</b>				<b>Contract Amount With Change Order No. 2</b>	
										<b>\$ 840,959.90</b>	

**Bjorn Berg**

---

**From:** Erik Diederich <ediederich@industrialbuilders.com>  
**Sent:** Tuesday, August 28, 2018 11:29 AM  
**To:** Bjorn Berg  
**Subject:** FM-15-F2 - Pay Application 2  
**Attachments:** FM\_15\_F2\_Pay\_Application\_2.pdf

**Follow Up Flag:** Follow up  
**Flag Status:** Completed

**[External Email]**

---

Bjorn –

Attached you will find a pay estimate for August. I completed quantities that we have finished. We will need to rely on John Freitag's survey info for topsoil and inspection trench along with the extra SY for pavement. In the estimate I have added 100SY for the extra disconnect and placed a note at the bottom that explains the 135 ton of extra Class 3 along with a proposed unit price of \$20 to deliver and place along with remove extra clay associated with the utility disconnect.

Thanks,

Erik Diederich  
Industrial Builders, Inc.

Office - 701.282.4977  
Cell - 701.412.3502



**Disclaimer**

The information contained in this communication from the sender is confidential. It is intended solely for use by the recipient and others authorized to receive it. If you are not the recipient, you are hereby notified that any disclosure, copying, distribution or taking action in relation of the contents of this information is strictly prohibited and may be unlawful.

This email has been scanned for viruses and malware, and may have been automatically archived by **Mimecast Ltd**, an innovator in Software as a Service (SaaS) for business. Providing a **safer** and **more useful** place for your human generated data. Specializing in; Security, archiving and compliance. To find out more [Click Here](#).

*Industrial Builders, Inc.*

---

PAUL W. DIEDERICH, PRESIDENT  
DONN O. DIEDERICH, EXECUTIVE VICE PRESIDENT



*General Contractors*

---

PHONE 701/282-4977 FAX 701/281-1409  
P.O. BOX 406 FARGO, NORTH DAKOTA 58107-0406

Bjorn Berg  
Houston Engineering  
1401 21<sup>st</sup> Ave N  
Fargo, ND 58102

Bjorn –

We are requesting a time extension for the home demolition portion of project FM-15-F2. We have removed all but one home, which is being delayed by Ottertail Power Company. The home mover has requested this extension and has provided a move date of Oct. 1<sup>st</sup> 2018. The basement has been removed already. I am requesting an extension until Oct. 4<sup>th</sup> 2018, to give some weather flexibility.

I have requested a letter from the home mover that will clarify the delay and provide written notice from the power company as to the forced delay.

Thanks,

Sincerely,  
Industrial Builders, Inc.

*Erik Diederich*

Erik Diederich  
Director of Business Development

REPORT OF ACTION

PUBLIC WORKS PROJECTS EVALUATION COMMITTEE

33

Project No. FM-15-K1 Type: Change Order #3  
 Location: Rosewood Addition Date of Hearing: 10/1/2018

<u>Routing</u>	<u>Date</u>
City Commission	<u>10/8/2018</u>
PWPEC File	<u>X</u>
Project File	<u>Roger Kluck</u>

The Committee reviewed the accompanying correspondence from Project Manager, Roger Kluck, for Change Order #3 in the amount of \$2,023.68 for additional rebar to reinforce 4x6-box culvert.

Staff is recommending approval of Change Order #3 in the amount of \$2,023.68, bringing the total contract amount to \$3,629,590.93.

On a motion by Bruce Grubb, seconded by Brenda Derrig, the Committee voted to recommend approval of Change Order #3 to Industrial Builders, Inc.

RECOMMENDED MOTION

Approve Change Order #3 in the amount of \$2,023.68 to Industrial Builders, Inc.

PROJECT FINANCING INFORMATION:

Recommended source of funding for project: Flood Sales Tax

	Yes	No
Developer meets City policy for payment of delinquent specials	<u>N/A</u>	<u>        </u>
Agreement for payment of specials required of developer	<u>N/A</u>	<u>        </u>
50% escrow deposit required	<u>N/A</u>	<u>        </u>

COMMITTEE

	Present	Yes	No	Unanimous
				<u>    <input checked="" type="checkbox"/>    </u>
Tim Mahoney, Mayor	<u>    <input checked="" type="checkbox"/>    </u>	<u>    <input checked="" type="checkbox"/>    </u>	<u>    <input type="checkbox"/>    </u>	
Nicole Crutchfield, Director of Planning	<u>    <input checked="" type="checkbox"/>    </u>	<u>    <input checked="" type="checkbox"/>    </u>	<u>    <input type="checkbox"/>    </u>	
Steve Dirksen, Fire Chief	<u>    <input checked="" type="checkbox"/>    </u>	<u>    <input checked="" type="checkbox"/>    </u>	<u>    <input type="checkbox"/>    </u>	
Bruce Grubb, City Administrator	<u>    <input checked="" type="checkbox"/>    </u>	<u>    <input checked="" type="checkbox"/>    </u>	<u>    <input type="checkbox"/>    </u>	
Ben Dow, Director of Operations	<u>    <input checked="" type="checkbox"/>    </u>	<u>    <input checked="" type="checkbox"/>    </u>	<u>    <input type="checkbox"/>    </u>	
Steve Sprague, City Auditor	<u>    <input checked="" type="checkbox"/>    </u>	<u>    <input checked="" type="checkbox"/>    </u>	<u>    <input type="checkbox"/>    </u>	
Brenda Derrig, City Engineer	<u>    <input checked="" type="checkbox"/>    </u>	<u>    <input checked="" type="checkbox"/>    </u>	<u>    <input type="checkbox"/>    </u>	
Kent Costin, Finance Director	<u>    <input checked="" type="checkbox"/>    </u>	<u>    <input checked="" type="checkbox"/>    </u>	<u>    <input type="checkbox"/>    </u>	

ATTEST:

B. E. D.

Brenda E. Derrig, P.E.  
 City Engineer

C: Kristi Olson



ENGINEERING DEPARTMENT  
225 4<sup>th</sup> Street North  
Fargo, North Dakota 58102  
Phone: (701) 241-1545  
Fax: (701) 241-8101  
E-Mail: Feng@FargoND.gov

# Memorandum

**To:** PWPEC  
**From:** Roger E Kluck, PE, CFM Civil Engineer II, Storm Water  
**C:** Jody Bertrand, Brenda Derrig  
**Date:** 9/26/2018  
**Re:** Project #FM-15-K1 Rosewood Area Flood Risk Management Project - Change Order #3

Background:

Project FM-15-K1 bids were opened on May 30, 2018 and the project awarded by the City Commission to Industrial Builders on June 4, 2018. Construction began on June 25, 2018.

The project continues construction of flood control on the north side of Rose Coulee across the Rosewood neighborhood. During construction of the lift station, the Contractor asked the Engineer to review the reinforcement where the 4x6-box culvert meets the lift station wall opening. It was determined that rebar should be added to make the connection more structurally sound. The computation of the work costs and related correspondence are attached. The change order amount is \$2,023.68 and is being paid for with Sales Tax Funds-Flood Control-460.

The requested change order item has been reviewed and is reasonable.

Recommended Motion:

To approve the requested Change Order #3 in the amount of \$2,023.68.

REK/klo  
Attachment

*Street Lighting  
Sidewalks*

*Design & Construction  
Traffic Engineering*

*Truck Regulatory  
Flood Plain Mgmt.*

*Mapping & GIS  
Utility Locations*





**CITY OF FARGO  
ENGINEERING DEPARTMENT  
CHANGE ORDER REPORT**

**Project No** FM-15-K1 **Change Order No** 3  
**Project Name** Rosewood Area Flood Risk Management Project  
**Date Entered** 9/26/2018 **For** Industrial Builders Inc

This change is made under the terms of or is supplemental to your present contract, if and when approved, you are ordered to perform the work in accordance with the additions, changes, or alterations hereinafter described.

**EXPLANATION OF CHANGE:** Rebar for lift station wall opening

IBI requested engineer clarify rebar for opening thru pump station wall for 6x4 box culvert. It was decided to add rebar to add extra factor of safety to hold box into structure.

Section	Line No	Item Description	Unit	Orig Cont Qty	Prev C/O Qty	Prev Cont Qty	Curr C/O Qty	Tot Cont Qty	Unit Price (\$)	C/O Ext Price (\$)
Storm Sewer Lift Station	85	F&I Floodwall Reinf Bars - Steel	LB	0.00	0.00	0.00	1,632.00	1,632.00	1.24	2,023.68
<b>Storm Sewer Lift Station Sub Total (\$)</b>										
2,023.68										

**Summary**

**Source Of Funding** Sales Tax Funds - Flood Control - 460  
**Net Amount Change Order # 3 (\$)** 2,023.68  
**Previous Change Orders (\$)** 177,873.35  
**Original Contract Amount (\$)** 3,449,693.90  
**Total Contract Amount (\$)** 3,629,590.93

I hereby accept this order both as to work to be performed and prices on which payment shall be based.

**CONTRACT TIME**

Description	Current Substantial Completion Date	Current Final Completion Date	Additional Days Substantial Completion	Additional Days Final Completion	New Substantial Completion Date	New Final Completion Date
	08/16/2019		0.00	0.00	08/16/2019	

**APPROVED**

**APPROVED DATE**

For Contractor 

Department Head

 10/4/18



**CITY OF FARGO  
ENGINEERING DEPARTMENT  
CHANGE ORDER REPORT**

Title

Mayor

Attest



3203 32nd Avenue South, Suite 201  
Fargo, ND 58103-6242  
701 232 5353  
KLJENG.COM

September 25, 2018

Jody Bertrand  
Division Engineer – Storm Sewer Utilities  
City of Fargo  
200 North 3rd Street  
Fargo, ND 58102

Re: FM-15-K1 – Lift Station Wall Opening Reinforcing Steel

Dear Jody:

On August 20, 2018, Industrial Builders, Inc. (IBI) submitted a request for information/clarification regarding the wall steel required around openings in lift station walls, particularly where it applies to the 6'x4' box culvert. Plan details assume round pipe. The "Structural Details-Lift Station" portion of the plans (Section 20 Sheet 10) contains notes referring to the "Structural Details-Gatewell" (Section 20 Sheet 9) for reinforcement details. IBI's request entailed clarifying which detail they should construct the openings to. KLJ directed IBI to use the detail found in the "Structural Details-Lift Station" plans (Section 20 Sheet 13). This detail depicts installation of 4 #9 bars at each corner in each mat, 9 feet longer than the opening dimension. Refer to attached plan sheets for details.

To avoid delays in their pour schedule, on August 20, 2018, IBI proceeded with KLJ's direction, installing 32 plain #9 bars, each 15 feet long. Later, KLJ determined that 3 #5 bars 11 feet long at each corner would suffice, but IBI had already purchased & installed materials from previous direction given. On September 19, 2018, IBI provided a cost breakdown to supply and install materials related to the extra work in the amount of \$2015.42. Upon review, KLJ recommends that \$2015.42 be paid to IBI.

If you have any questions or require additional information, please feel free to contact me at 701.241.2317 or [Cassie.McNames@kljeng.com](mailto:Cassie.McNames@kljeng.com)

Sincerely,

KLJ

A handwritten signature in cursive script that reads "Cassie McNames".

Cassie McNames  
Structural Engineer

Enclosure(s): IBI Material Cost Breakdown  
Project #: 14415102

cc: Brady Haussler (KLJ), Scott Middaugh (KLJ), Troy Erickson (IBI), Roger Kluck (City of Fargo)

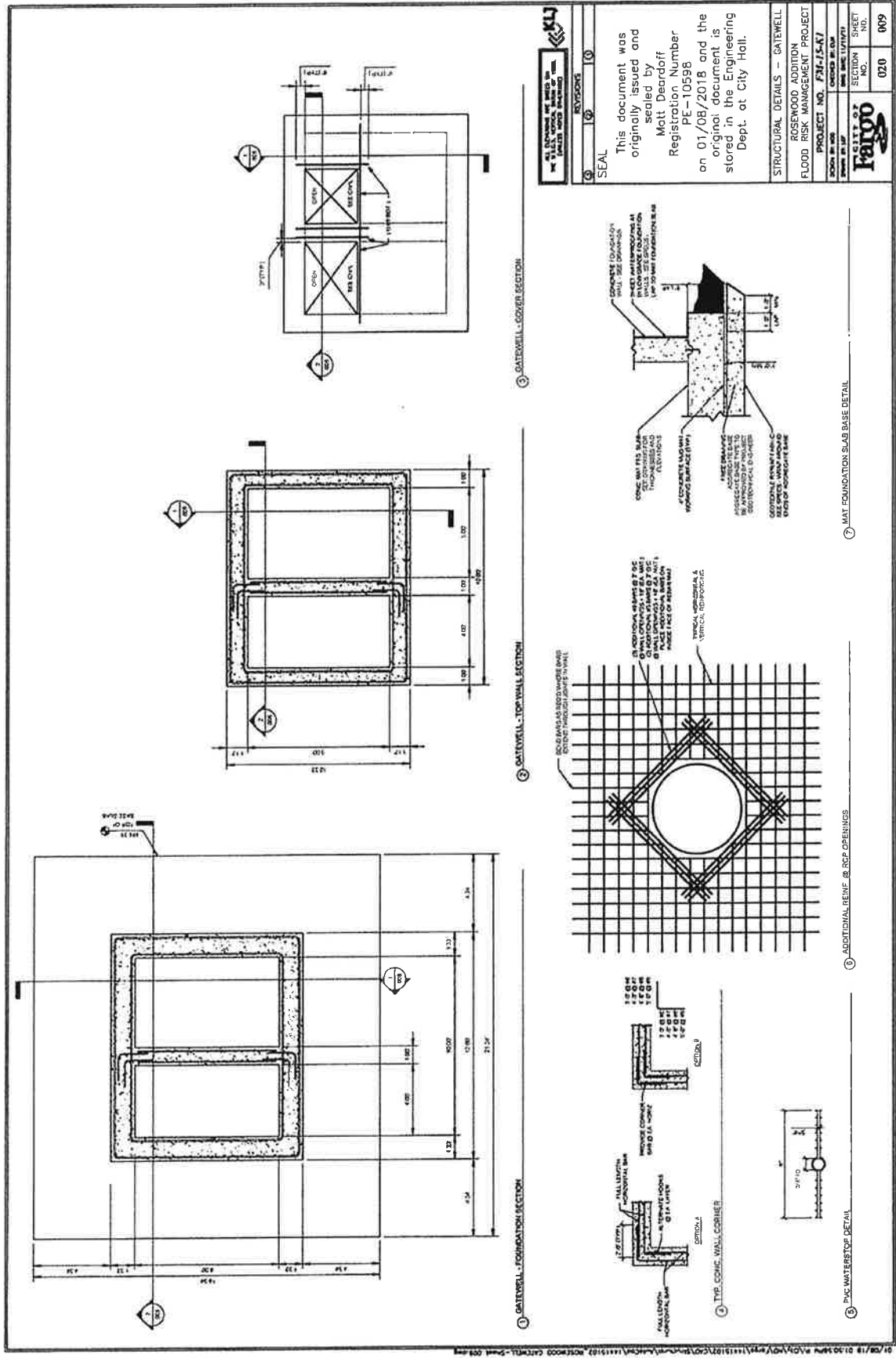

**SEAL**  
 This document was originally issued and sealed by **Matt Deardoff**, Registration Number **PE-10598** on **01/08/2018** and the original document is stored in the Engineering Dept. at City Hall.

**STRUCTURAL DETAILS - GATEWELL**  
 ROSEWOOD ADDITION  
 FLOOD RISK MANAGEMENT PROJECT  
 PROJECT NO. **FR-15-17**  
 DRAWN BY **MEC**  
 CHECKED BY **MEC**  
 SHEET NO. **020**  
 OF **009**

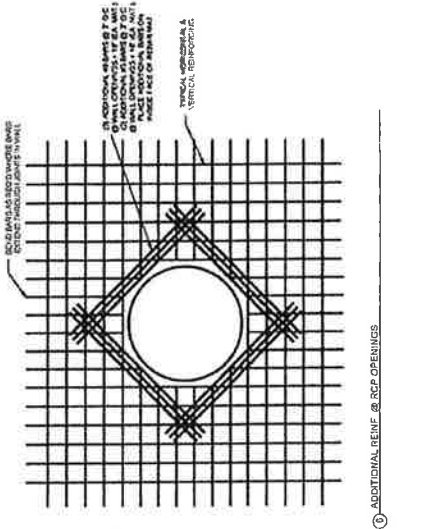
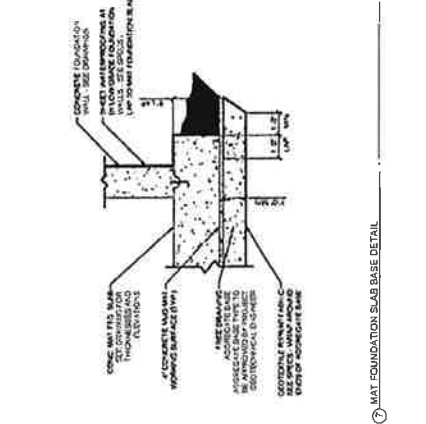

ALL DIMENSIONS ARE IN FEET AND INCHES UNLESS OTHERWISE SPECIFIED
<b>REVISIONS</b>
<b>SEAL</b>
This document was originally issued and sealed by <b>Matt Deardoff</b> , Registration Number <b>PE-10598</b> on <b>01/08/2018</b> and the original document is stored in the Engineering Dept. at City Hall.
<b>STRUCTURAL DETAILS - GATEWELL</b>
ROSEWOOD ADDITION
FLOOD RISK MANAGEMENT PROJECT
PROJECT NO. <b>FR-15-17</b>
DRAWN BY <b>MEC</b>
CHECKED BY <b>MEC</b>
<b>CITY OF Fairport</b>
SHEET NO. <b>020</b>
OF <b>009</b>

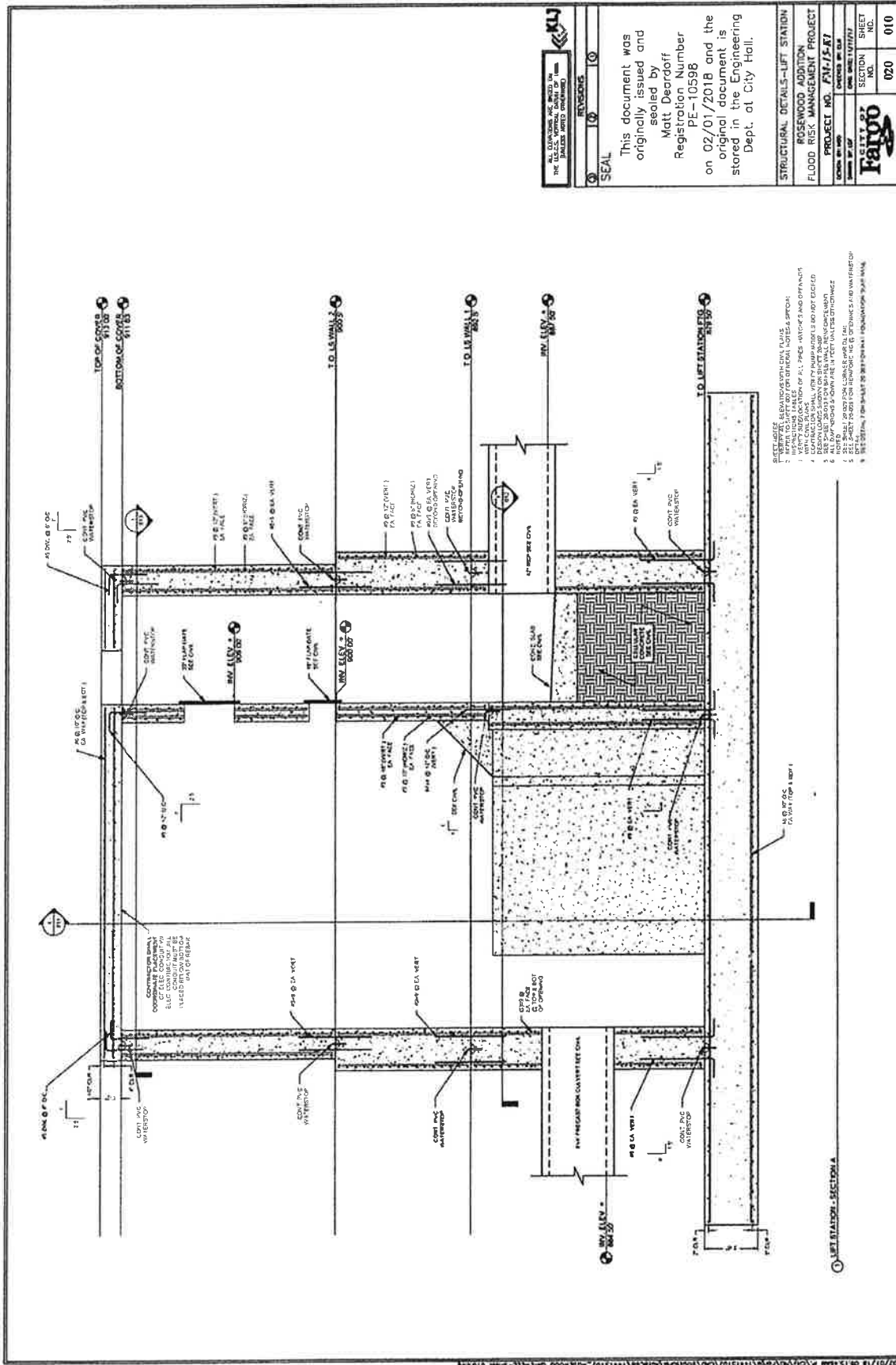

- 1. REBAR DETAILING WITH CON. PLANS
- 2. REBAR DETAILING SHALL BE APPROVED BY THE ARCHITECT
- 3. ALL REBAR SHALL BE EPOXY COATED
- 4. ALL REBAR SHALL BE PROTECTED BY A CORROSION INHIBITOR
- 5. ALL REBAR SHALL BE INSTALLED IN ACCORDANCE WITH THE SCHEDULED MATERIAL SPECIFICATIONS
- 6. ALL REBAR SHALL BE INSTALLED IN ACCORDANCE WITH THE SCHEDULED MATERIAL SPECIFICATIONS
- 7. ALL REBAR SHALL BE INSTALLED IN ACCORDANCE WITH THE SCHEDULED MATERIAL SPECIFICATIONS
- 8. ALL REBAR SHALL BE INSTALLED IN ACCORDANCE WITH THE SCHEDULED MATERIAL SPECIFICATIONS

SEAL REVISIONS	
0	
1	
2	
This document was originally issued and sealed by Matt Deardoff Registration Number PE-10598 on 02/01/2018 and the original document is stored in the Engineering Dept. at City Hall.	
STRUCTURAL DETAILS - LIFT STATION ROSEWOOD ADDITION FLOOD RISK MANAGEMENT PROJECT PROJECT NO. 237-2-17 SHEET NO. 020 OF 010 DATE: 07/13/2018	
<b>Hayco</b>	
SECTION NO. 020 SHEET NO. 010	

SECTION - SECTION A

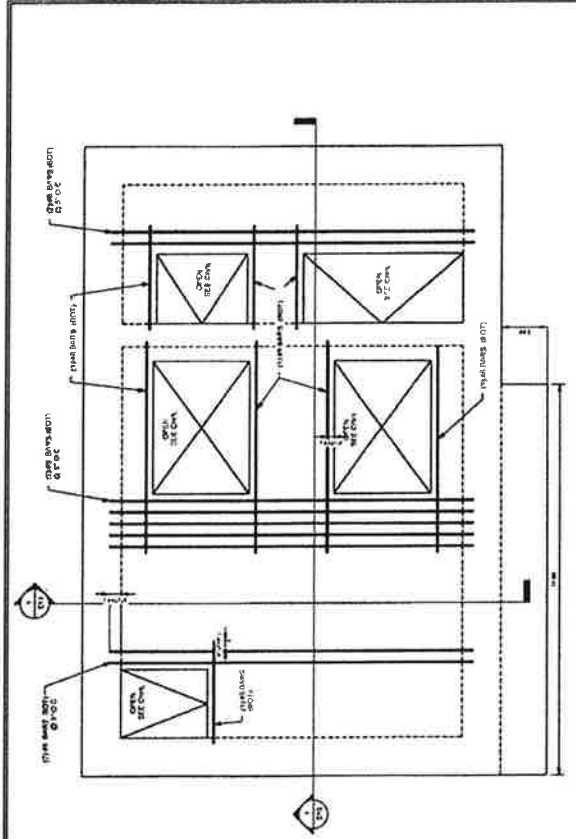

② LIFT STATION - COVER SECTION

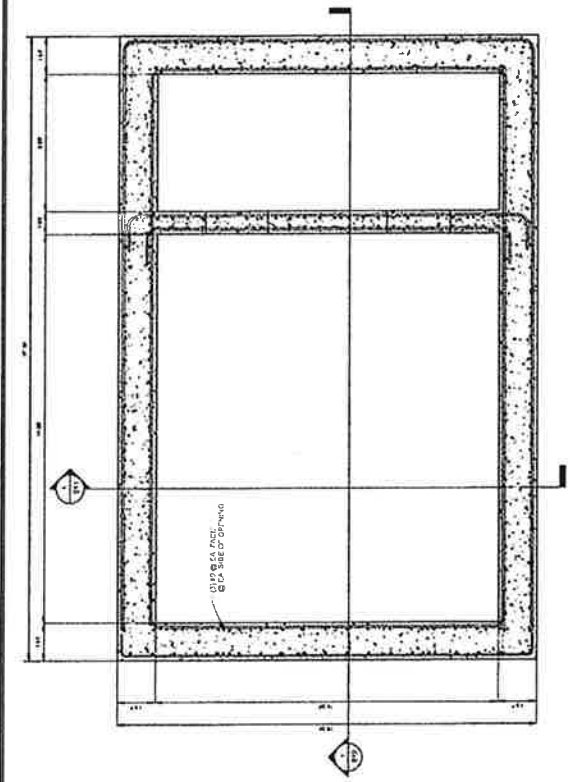

① LIFT STATION - TOP WALL SECTION

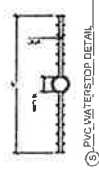

③ PVC WATER STOP DETAIL

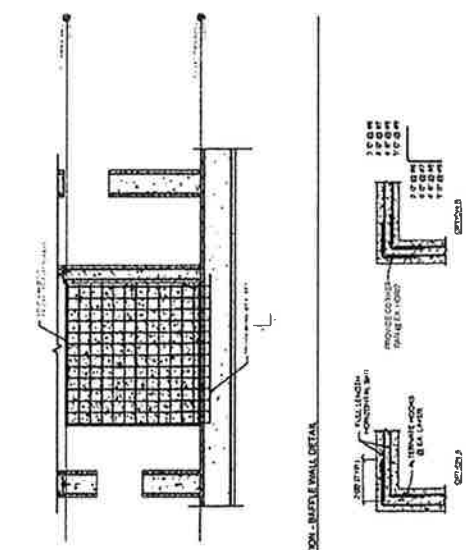

④ LIFT STATION - BASE & WALL DETAIL

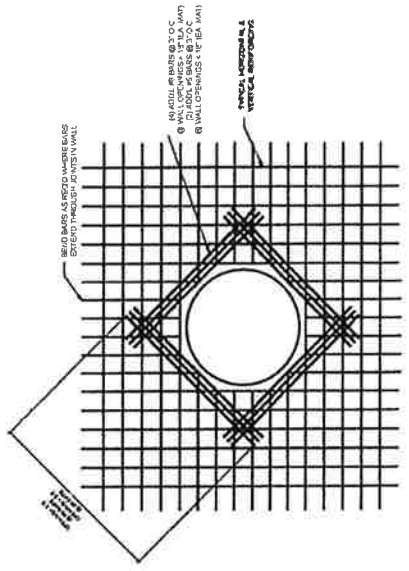

⑤ ADDITIONAL REINF. @ RC2 OPENINGS

**REVISED**

NO. OF REVISIONS: 10

DATE: 01/08/2018

BY: MATT DEARDORFF

**SEAL**

This document was originally issued and sealed by  
**Matt Deardorff**  
 Registration Number  
**PE-10598**  
 on 01/08/2018 and the original document is stored in the Engineering Dept. at City Hall.

**STRUCTURAL DETAILS - LIFT STATION**

ROSEWOOD ADDITION  
 FLOOD RISK MANAGEMENT PROJECT

PROJECT NO. **PM-15-A1**

DATE: 01/08/2018

SCALE: AS SHOWN

**RAIPO**

RAISE AND IMPROVE

SECTION	SHEET
NO.	NO.
020	013

*Industrial Builders, Inc.*

PAUL W. DIEDERICH, PRESIDENT  
DONN O. DIEDERICH, EXECUTIVE VICE PRESIDENT



*General Contractors*

PHONE 701/282-4877 FAX 701/281-1409  
P.O. BOX 406 FARGO, NORTH DAKOTA 58107-0406

September 25, 2018

KLJ  
3203 32nd Ave S Suite 201  
Fargo, ND 58103-6242

Attn: Brady Haussler

Re: Rosewood Flood Risk Mgmt FM-15-K1 – Lift Station Rebar

Dear Mr. Haussler,

Following is a breakdown of the extra cost to supply and install an additional 32 Ea 15' #9 bars in the lift station.

- Material, Sales tax and 15% markup (invoice attached) \$1087.90
- Subcontractor installation w/ 10% markup \$ 592.42
- Hook service – 1 hr Crane and operator \$ 222.55
- Freight – 1 hr Flatbed and operator \$ 112.55
- Total \$2015.42

Please issue a change order for this work at your earliest convenience.

If any additional information is required, please call or email.

Sincerely,  
INDUSTRIAL BUILDERS, INC.

Troy Erickson  
Vice President of Engineering

Encl.

Cc: IBI Job File 18203  
Matt Pollert

Mid America Steel, Inc.  
 92 NP Ave  
 P.O. Box 2807  
 Fargo, ND 58108  
 Phone: (701) 232-8831  
 Fax: (701) 280-0103



B36422

**RECEIVED**  
 AUG 27 2018

SOLD TO INDUSTRIAL BUILDERS INC  
 BOX 406  
 FARGO, ND 58107

SHIP TO

Industrial Builders, Inc.  
 Fargo, N.D.

ACCOUNT NO	ORDER	SHIP TO	DATE	TERMS	DATE	QUANTITY
19460	Troy	Pick Up	8/22/2018	Net 30	8/24/2018	1

JOB NUMBER	QUANTITY	DESCRIPTION	UNIT PRICE	EXTENDED
	1	Lot of Rebar: 32 - #9 x 15'0	880.00	880.00

ITEM TOTAL 880.00  
 TAX 66.00

**TOTAL AMOUNT 946.00**

**RECEIVED**  
 AUG 27 REC'D  
 By \_\_\_\_\_

Trans# \_\_\_\_\_ Posted on: (Job to GL Code)

Job  Subc  Equip  OtherG/L \_\_\_\_\_  
 Job  Subc  Equip  OtherG/L \_\_\_\_\_

Entered: \_\_\_\_\_ By: \_\_\_\_\_



PUBLIC WORKS PROJECTS EVALUATION COMMITTEE

3A

Project No. MS-18-J0 Type: Electrical Design Services

Location: Lift Stations 3, 8, 10, 36, 49 & 50 Date of Hearing: 10/1/2018

<u>Routing</u>	<u>Date</u>
City Commission	10/8/2018
PWPEC File	X
Project File	Rob Hasey

The Committee reviewed a communication from Project Manager, Rob Hasey, regarding recently solicited quotes for electrical design services for six storm sewer lift stations. These lift stations will be rehabilitated in 2019 to replace pumps, motors, controls, catwalks, lighting, safety equipment and SCADA communications. The recommended funding source is Storm Sewer Utility Funds for the underpass lift stations (3 & 50) and Special Assessments for the remaining lift stations.

Three quotes were received as follows:

- HDR: \$34,300
- AE2S: \$37,500
- Apex: \$53,904

Staff is recommending to approve AE2S to perform the electrical design services. They have designed several new and replacement control panel projects in the past and are currently under contract for implementing our SCADA network.

On a motion by Ben Dow, seconded by Kent Costin, the Committee voted to approve the selection of AE2S to perform the electrical design services in the amount of \$37,500.

RECOMMENDED MOTION

Concur with the recommendations of PWPEC and approve the selection of AE2S to perform the electrical design services in the amount of \$37,500.

PROJECT FINANCING INFORMATION:

Recommended source of funding for project: Storm Sewer Utility Funds & Special Assessments

	<u>Yes</u>	<u>No</u>
Developer meets City policy for payment of delinquent specials		N/A
Agreement for payment of specials required of developer		N/A
Letter of Credit required (per policy approved 5-28-13)		N/A

COMMITTEE

	<u>Present</u>	<u>Yes</u>	<u>No</u>	<u>Unanimous</u>
				<input checked="" type="checkbox"/>
Tim Mahoney, Mayor	<input checked="" type="checkbox"/>	<input checked="" type="checkbox"/>	<input type="checkbox"/>	
Nicole Crutchfield, Director of Planning	<input checked="" type="checkbox"/>	<input checked="" type="checkbox"/>	<input type="checkbox"/>	
Steve Dirksen, Fire Chief	<input checked="" type="checkbox"/>	<input checked="" type="checkbox"/>	<input type="checkbox"/>	
Bruce Grubb, City Administrator	<input checked="" type="checkbox"/>	<input checked="" type="checkbox"/>	<input type="checkbox"/>	
Ben Dow, Director of Operations	<input checked="" type="checkbox"/>	<input checked="" type="checkbox"/>	<input type="checkbox"/>	
Steve Sprague, City Auditor	<input checked="" type="checkbox"/>	<input checked="" type="checkbox"/>	<input type="checkbox"/>	
Brenda Derrig, City Engineer	<input checked="" type="checkbox"/>	<input checked="" type="checkbox"/>	<input type="checkbox"/>	
Kent Costin, Finance Director	<input checked="" type="checkbox"/>	<input checked="" type="checkbox"/>	<input type="checkbox"/>	

*B. E. Derrig*

ATTEST:

C: Kristi Olson

Brenda E. Derrig, P.E.  
City Engineer



ENGINEERING DEPARTMENT  
225 4<sup>th</sup> Street North  
Fargo, North Dakota 58102  
Phone: (701) 241-1545  
Fax: (701) 241-8101  
E-Mail: Feng@FargoND.gov

## Memorandum

**To:** Members of PWPEC  
**From:** Rob Hasey, Civil Engineer I, Storm Sewer Utility  
**C:** Jody Bertrand, Division Engineer  
**Date:** 10/01/2018  
**Re:** Project #MS-18-J0 – Electrical Design Services

---

**Background:**

The Engineering Department recently solicited quotes from several Consultants for electrical design services for six storm sewer lift stations (#3, #8, #10, #36, #49 & #50). These storm lift stations will be rehabilitated in 2019 to replace pumps, motors, controls, catwalks, lighting, safety equipment and SCADA communications.

We received three quotes and they are as follows:

- HDR: \$34,300
- AE2S: \$37,500
- Apex: \$53,904

**Recommended Motion:**

The recommended motion is to approve AE2S to perform the electrical design services. AE2S has designed several new and replacement control panel projects in the past and are currently under contract for implementing our SCADA network. HDR has been involved with the construction of three storm sewer lift stations recently, but have not been too involved with the SCADA portion. We feel that AE2S's familiarity with our control panel schematics, specifications and the knowledge of our SCADA system will provide a smoother process of plan and specification production for the rehabilitation project.

The recommended source of funding is Storm Sewer Utility Capital Improvement Funds for the underpass lift stations (#3 & #50) & Special Assessments for the remaining lift stations.

*Street Lighting  
Sidewalks*

*Design & Construction  
Traffic Engineering*

*Truck Regulatory  
Flood Plain Mgmt.*

*Mapping & GIS  
Utility Locations*



Water | Transportation | Municipal | Facilities

701.373.7980  
4733 Amber Valley Parkway  
Fargo, ND 58104

September 7, 2018

Mr. Rob Hasey  
Storm Sewer Utility Engineer  
City of Fargo Engineering Department  
200 North 3<sup>rd</sup> Street  
Fargo, ND 58102

RE: City of Fargo Project #MS-18-J0 – Electrical Design Services  
Cost Proposal

Dear Mr. Hasey:

Attached you will find our cost proposal and the associated tasks, hours and rates for the City of Fargo Project #MS-18-J0 – Electrical Design Services as requested in your Project Scoping Request. We understand if Apex is selected for these services that a task order will be prepared as per our Master Services Agreement already on file.

We have reviewed the Project Scoping Request and the amount of information you are requesting the consultant to provide.

The staff we have dedicated to work on this project are:

Dain Miller, PE – Principal Engineer  
Kyle Koterba, PE – Lead Engineer / Project Manager  
John Klein, PE – Lead Engineer  
Wes Gullicks, PE – Lead Engineer

Please feel free to give us a call if you have any questions.

Sincerely,

Apex Engineering Group, Inc.

A handwritten signature in cursive script that reads "Dain L. Miller".

Dain L. Miller, PE  
Vice President /Principal

# City of Fargo Project #MS-18-J0 Electrical Design Service Cost Proposal



9/7/2018

Task	Principal	Lead Engineer	Design Engineer	Graduate Engineer	Eng. Technician	Staff Support	Task Hours	Fee Total
<b>Task 1.0 Project Management</b>								
Standard Apex Rate	\$175	\$165	\$131	\$106	\$90	\$88		
1.01 Meetings with City Staff (Two meetings)		8					8	\$ 1,320.00
1.02 Misc. Coordination with City Staff	4	16					20	\$ 3,340.00
1.03 Invoicing & Billing Review		8				8	16	\$ 2,024.00
<b>Task Subtotal</b>	<b>4</b>	<b>32</b>	<b>0</b>	<b>0</b>	<b>0</b>	<b>8</b>	<b>44</b>	<b>\$ 6,684.00</b>
<b>Task 2.0 Conceptual Design &amp; Contract Documents</b>								
2.01 Evaluate the existing site conditions		12					12	\$ 1,980.00
2.02 Create Schematic Drawings		32					32	\$ 5,280.00
2.03 Design Development		48					48	\$ 7,920.00
2.04 Prepare Contract Documents - Plans		48			40		88	\$ 11,520.00
2.05 Prepare Contract Documents - Specifications		48					48	\$ 7,920.00
2.06 Prepare Cost Estimates		12					12	\$ 1,980.00
2.07 Final Review of the Documents	4	32					36	\$ 5,980.00
2.08 Shop Drawing Review		16					16	\$ 2,640.00
<b>Task Subtotal</b>	<b>4</b>	<b>248</b>	<b>0</b>	<b>0</b>	<b>40</b>	<b>0</b>	<b>292</b>	<b>\$ 45,220.00</b>
<b>Project Mgmt &amp; Conceptual Design</b>	<b>8</b>	<b>280</b>	<b>0</b>	<b>0</b>	<b>40</b>	<b>8</b>	<b>336</b>	<b>\$ 51,904.00</b>
Subconsultant Fees = \$ -								
Reimbursable Expenses = \$ 2,000.00								
<b>TOTAL NOT TO EXCEED = \$ 53,904.00</b>								
<b>Reimbursable Expenses Estimate</b>								
<b>Reimbursable Expenses Estimate</b>								<b>\$ 2,000.00</b>



September 4, 2018

Rob Hasey  
Storm Sewer Utility Engineer  
City of Fargo  
200 North 3<sup>rd</sup> Street  
Fargo, ND 58102

**RE: City of Fargo Project #MS-18-J0 - Electrical Design Services  
Rehabilitation to Lift Station #3, #8, #10, #36, #49, and #50**

Dear Rob:

Thank you for the opportunity to submit this letter proposal for professional electrical engineering services for the proposed City of Fargo Project #MS-18-J0. As requested, AE2S is proposing to provide the following scope of services:

- ✓ Attend one pre-design coordination meeting with City staff.
- ✓ Conduct site visits, as required, to collect all necessary information to complete our design.
- ✓ Design of a new control panel and any control panel components necessary to operate the lift station pumps, lighting, mechanical, and Supervisory Control and Data Acquisition (SCADA) communications. The pump controls shall be programmable logic controller (PLC) based and shall operate the pumps using a level transducer for primary on/off operation and a set of redundant floats in the event of transducer failure.
- ✓ Conduct an NFPA 820 "Standard for Fire Protection in Wastewater Treatment and Collection Facilities 2016 Edition" assessment. Table 4.2.2 rows 3 through 5 apply to this application.
- ✓ Prepare Drawings, including:
  - Demolition Drawing
  - Hazardous Area Classification Drawing (NFPA 820 Results)
  - Site Plan
  - Electrical Plan View
  - Section Views (if required)
  - One-Line Diagram
  - Typical Details
  - Typical Wiring Schematics
  - I/O Schedules
- ✓ Prepare Division 16 Specifications, including:
  - 16000 – Electrical General Conditions
  - 16210 – Conduit
  - 16220 – Conductors (Less Than 600V)

Rob Hasey  
September 4, 2018

Page 2 of 3

**RE: City of Fargo Project #MS-18-J0 - Electrical Design Services  
Rehabilitation to Lift Station #3, #8, #10, #36, #49, and #50**

- 16230 – Outlet Boxes, Junction Boxes, and Pull Boxes
- 16250 – Labeling & Equipment Identification
- 16260 – Grounding
- 16270 – Excavating, Trenching, and Backfilling
- 16455 – Wiring Devices
- 16900 – Lift Station Controls
- *Note, depending on the equipment required additional specification sections may be included such as panelboards, disconnects, surge protective devices, etc.*
- ✓ Prepare a construction cost estimate for electrical related items.
- ✓ Conduct all required SCADA Master PLC and Human Machine Interface (HMI) programming to integrate the lift station into the SCADA System.
  - *Note, it is assumed that the Systems Integrator providing the new controls will provide the required programming of the local site PLC and operator interface terminal (OIT) for specific desired pump station operation.*
- ✓ Complete a radio path study to determine the required antenna height to communicate with the City's SCADA base station located on Water Tower #6 at 32<sup>nd</sup> Avenue South between 32<sup>nd</sup> Street South and 33<sup>rd</sup> Street South.
  - *Note, if the radio path study results suggest an antennae height that would result in the installation of a self-supporting antennae tower, additional Engineering Fees may be required.*
- ✓ Construction Administration Services include:
  - Electrical and Controls equipment shop drawing review.
- ✓ AE2S personnel which have been scheduled to perform the tasks noted above include:
  - Adam Wahler, PE (Electrical Engineer)
    - Project Manager and Lead Electrical Engineer
  - Nick Ackerman, EIT (Electrical Engineer)
    - Electrical Engineering Technician
  - Jason Salber, EIT (Electrical Engineer)
    - Designer
  - Adam Kubista
    - Instrumentation and Controls SCADA Programming
  - Peter Manfredini
    - CAD Technician
  - Ian Smith
    - CAD Technician
- ✓ The following project schedule was discussed and is acceptable:
  - September 18, 2018: Task order issued.
  - September 24 - 26, 2018: Pre-design meeting and site visit with City staff.
  - October 9 -10, 2018: Design meeting and discussion of site visit evaluations.
  - November 16, 2018: Submit 90% design plans for City comment and review.

Rob Hasey  
September 4, 2018

Page 3 of 3

**RE: City of Fargo Project #MS-18-J0 - Electrical Design Services  
Rehabilitation to Lift Station #3, #8, #10, #36, #49, and #50**

- December 7, 2018: Submit wet stamped drawings, PDF with digital stamp, and AutoCAD (CAD) drawings.
- ✓ We assume that the following information will be provided by the City of Fargo:
  - CAD Drawings including site plans, plan views, section views, title blocks, and any other required drawings.
- ✓ We propose to provide the following deliverables to the City:
  - Stamped hard copies of all project drawings.
  - Project CAD drawings compatible with AutoCAD Civil 3D 2017, using the City's standard CAD sheet layout.
  - Electrical Specifications in 'SIB' 11" x 17" format.

**We propose to complete this scope of services at an hourly rate not to exceed \$37,500.**

Thank you for this opportunity to submit to the City on this project. If you are satisfied with our proposed scope and fee, please provide AE2S a Task Order in accordance with the Master Services Agreement for our review and approval. Please let us know if you have any comments or questions.

Submitted in Service,  
AE2S



Adam Wahler, PE (ND, MN, SD, MT, UT, AZ, TX, MI)  
Electrical Engineer



September 7, 2018

Dear Mr. Hasey,

Thank you for sending the scoping Request for the Electrical Design Services for project number MS-18-J0. As stated in the request, we are anticipating updating 6 Storm water lift stations which include lift stations #3, #8, #10, #36, #49, and #50.

The HDR Project team will consist of:

- Brian King – Project Manager

Brian has more than 18 years of experience in the municipal civil engineering field. The last 10 years Brian has been involved with numerous projects throughout the City of Fargo. He is well versed in the city's processes and submittal guidelines thus providing efficient and organized approach to the project completion.

- Dave Penner, PE – I&C Controls Project Lead

David's engineering background includes control system and automation design services for a variety of clients, including power and industrial clients. David's electrical control system design includes preparing process and instrument diagrams (P&IDs), logic diagrams, loop diagrams, instrument installation details, and technical specifications for the purchase and installation of instrumentation and control systems. His other responsibilities have included PLC programming, on-site construction services, and plant inspections. David has been responsible for the technical design of various aspects of instrumentation and SCADA systems, including Human-Machine-Interface (HMI) software, process control and monitoring strategies, data management, and telemetry/networking.

- Kyle Ganskop, PE – Electrical Project Lead

Kyle has more than 20 years of field experience in the electrical contracting business. He has performed electrical system controls and instrumentation design for numerous water systems, wastewater systems, reclaimed water systems, solid waste facilities, industrial facilities, and government facilities.

- Kaitlyn Evans, EIT – I&C Controls Designer

Kaitlyn provides design support by specifying instrumentation and equipment as well as developing control narratives and I/O lists. She verifies documentation control by updating



P&IDs, control wiring diagrams, instrument lists, system descriptions, and operating instructions.

- Derek Edwards, EIT – Electrical Designer

Derek is an electrical designer supporting our systems and control specialists. His experience includes preparing process and instrument diagrams (P&IDs), logic diagrams, loop diagrams, instrument installation details.

The total fee to complete the work outlined in the scoping request is **\$ 34,300.**

Should you have any additional questions or comments, feel free to contact me at 701.353.6117. We appreciate your time and the opportunity to provide a quote for this project.

Sincerely,

HDR Engineering Inc.



Brian King, PE  
*Office Manager*



Jason Kjenstad, PE  
*Vice President/Area Manager*

REPORT OF ACTION

PUBLIC WORKS PROJECTS EVALUATION COMMITTEE

35

Project No. FM-14-71 (6228) Type: Amendment #1  
 Location: Drain 27 Date of Hearing: 10/1/2018

<u>Routing</u>	<u>Date</u>
City Commission	<u>10/8/2018</u>
PWPEC File	<u>X</u>
Project File	<u>Jody Bertrand</u>

The Committee reviewed the accompanying correspondence from Division Engineer, Jody Bertrand, related to Amendment #1 in the amount of \$396,182.00 for additional work due to changes in the scope of the project. Houston Engineering was selected through an RFP and performed the original task along with additional work in conjunction with the levee construction within the Flood Comprehensive Plan. When the Revised Flood Comprehensive Plan was adopted and the adjacent levee projects were removed, there was still a need for the reconstruction of the storm water lift stations. This amendment is for the completion of the design and plans, construction administration and inspection.

Staff is recommending approval.

On a motion by Bruce Grubb, seconded by Brenda Derrig, the Committee voted to recommend approval of Amendment #1.

RECOMMENDED MOTION

Concur with PWPEC recommendation and approve Amendment #1 with Houston Engineering in the amount of \$396,182.00.

PROJECT FINANCING INFORMATION:

Recommended source of funding for project: Flood Sales Tax (460)

	<u>Yes</u>	<u>No</u>
Developer meets City policy for payment of delinquent specials	<u>N/A</u>	<u>N/A</u>
Agreement for payment of specials required of developer	<u>N/A</u>	<u>N/A</u>
Letter of Credit required (per policy approved 5-28-13)	<u>N/A</u>	<u>N/A</u>

COMMITTEE

	<u>Present</u>	<u>Yes</u>	<u>No</u>	<u>Unanimous</u>
Tim Mahoney, Mayor	<input checked="" type="checkbox"/>	<input checked="" type="checkbox"/>	<input type="checkbox"/>	<input checked="" type="checkbox"/>
Nicole Crutchfield, Director of Planning	<input checked="" type="checkbox"/>	<input checked="" type="checkbox"/>	<input type="checkbox"/>	
Steve Dirksen, Fire Chief	<input checked="" type="checkbox"/>	<input checked="" type="checkbox"/>	<input type="checkbox"/>	
Bruce Grubb, City Administrator	<input checked="" type="checkbox"/>	<input checked="" type="checkbox"/>	<input type="checkbox"/>	
Ben Dow, Director of Operations	<input checked="" type="checkbox"/>	<input checked="" type="checkbox"/>	<input type="checkbox"/>	
Steve Sprague, City Auditor	<input checked="" type="checkbox"/>	<input checked="" type="checkbox"/>	<input type="checkbox"/>	
Brenda Derrig, City Engineer	<input checked="" type="checkbox"/>	<input checked="" type="checkbox"/>	<input type="checkbox"/>	
Kent Costin, Finance Director	<input checked="" type="checkbox"/>	<input checked="" type="checkbox"/>	<input type="checkbox"/>	

ATTEST:

C: Kristi Olson

  
 Brenda E. Derrig, PE  
 City Engineer



## Memorandum

**To:** PWPEC  
**From:** Jody Bertrand, Division Engineer  
**Date:** 10/1/2018  
**Re:** Project No. FM-14-71 (6228) – Drain 27 Flood Risk Management Project  
Contract Amendment #1 Request

---

Background:

City Project No. FM-14-71 (6228) was initiated in July of 2013 through agreement with Houston Engineering. At that time, the project included the design and construction of levee and floodwall segments totaling about 2,500 lineal feet. The concept plans included in the RFP showed new levee segments on the north and south sides of Drain #27 with short segments of floodwall where adequate space was not available. Levee heights were proposed in the range of 6-8 feet depending on the location. Portions of the drain on the north and south side have had levee improvements installed prior to 2013. The connection of the existing levee segments was to be completed through the proposed improvements for this project.

The project was intended to be completed in two phases with a north and south portion respectively. The first phase of construction was scheduled to begin in 2016 and was to include the south side improvements along the drain and a new storm sewer lift station adjacent to 42<sup>nd</sup> Street South. During the spring of 2016, the Revised Flood Comprehensive plan was adopted by City Commission, which modified the improvements along Drain #27 west of I-29. The levee and floodwall improvements were dropped from the plan and only the improvements to the Lift Stations were carried forward as part of the new revised plan.

With the removal of the levee and floodwall proposed improvements, the Engineering Department is proposing to construct both new lift stations under the same contract to simplify project coordination in the area and hopefully receive economies of scale to help reduce the overall construction costs.

The original contract signed by Houston Engineering for this project was for the development of project concept plans and the design of phase 1, which included the south side lift station, but not the construction administration and inspection services, in the amount of \$271,132.00. With the proposed Contract Amendment 1, Houston Engineering has proposed to design the north side lift station and complete the construction services for both lift station project locations.

The total cost being proposed under Contract Amendment #1 is \$396,182 for the additional work that is being completed by Houston Engineering for design, construction administration, and inspection services for Lift Stations #55 and #56 (north and south sides of Drain #27 at 42<sup>nd</sup> Street South). Attached documents have proposed hours for the proposed engineering services.

Recommend Motion:

Approve Contract Amendment #1 submitted by Houston Engineering in the amount of \$396,182, which would bring the new contract total amount to \$667,314.

Fargo Corporate Office 701.237.5065 701.237.5101

1401 21st Avenue North Fargo ND 58102



**ENGINEERING SERVICES AGREEMENT**

**AMENDMENT NO. 1**

**Project:** City of Fargo Project No. 6228 (FM-14-71)  
Drain 27 Flood Risk Management Project  
(Interstate 29 to 42<sup>nd</sup> Street South)  
HE Project No. 6059-062

**Client:** City of Fargo  
200 North 3<sup>rd</sup> Street  
Fargo, ND 58102  
Phone (701) 241-1545

**Location of Project:** City of Fargo, Cass County, North Dakota

**Description of Work:** This contract amendment is to provide additional services to address changes to Phase No. 1 of the project design and construction phase. This generally includes changes to the project extents in the area along the south side of the drain between 42<sup>nd</sup> Street and Interstate 29, and the area directly NW of the 42<sup>nd</sup> St crossing of Drain 27. The original contract for this project design was signed in August of 2013. Since that time, we have been coordinating with the city staff develop a modified project configuration for Phase 1. The most significant project changes in this reach include the addition of a pump station and gravity gatewell facility NW of the 42<sup>nd</sup> St crossing of Drain 27 (NW Pump Station), and a reduction of the extent of the flood risk management features to include only the area south of the drain from 42<sup>nd</sup> St to the existing Swanson Health facility (SE Pump Station). The approximate extents of the NW Pump Station portion of the project are shown on **Attachment 1**. The revised project extents for the portion of the project south of the drain are shown on **Attachment 2**. In addition, the construction schedule has changed. Construction is now expected to be completed in 2019.

The additional services associated with Phase 1 are detailed below are based on the following general breakdown categories:

Bismarck 701.325.0200 701.325.0300 Minot 701.852.7951 701.858.5655  
Macle Grove 763.493.4522 763.493.5572 Fair River Falls 218.681.2931 218.681.2987

### 1. Task 1 - Additional Design Phase Services

The significant **Additional Design Phase Services** items include the tasks in each category listed below. Preliminary design has been completed for the portions of the project south of Drain 27. Under this task, the design of the SE Pump Station will be extended from its current state through final design. Additionally, preliminary and final design of the NW Pump Station will be completed as part of this task.

- Project Administration
  - Added property owner coordination/meetings for revised project extents
  - Additional option review coordination (NW pump station)
  - City coordination on options (NW Pump Station)
- Preliminary Survey
  - Detailed surveys of north and south side properties
  - Small utilities locations (NW Pump Station)
  - Public utilities locations (NW Pump Station)
- Preliminary Engineering (30% - NW Pump Station)
  - Additional option and pump station siting evaluations (NW Pump Station)
  - Cost estimating
  - Preliminary hydraulic and interior drainage analysis (NW Pump Station)
- Final Design and Plan Preparation (90%/100% - Both Sites)
  - Lift station and associated features
  - Gatewell structure
  - Electrical design coordination
  - Storm sewer design
  - Private utility relocation planning
  - Public utility relocation planning
  - Right-of-way mapping
  - Traffic control planning

The estimated cost of the **Additional Design Phase Services** is \$148,298 as detailed in **Attachment 1**. The estimated cost is based on the following assumptions:

- The NW Pump Station will be located west of 42<sup>nd</sup> St as shown on **Attachment 1**.
- The layout and features of the SE Pump Station site and structure geometry will not significantly deviate from the current layout as previously coordinated with the City and shown on **Attachment 2** as the result of the 90% review or other City reviews.
- Plans will be developed for the removal of the pump station and gatewell north of the drain as part of this amendment. Shoring for excavations will be the responsibility of the contractor. Shoring plans and analysis will not be completed by HEI.
- Any expansion or modification of the project extents beyond the extents shown in **Attachments 1 & 2** will require an additional amendment.

## 2. Revised Construction Services

The **Revised Construction Services** result primarily from the significant changes to the project extents from the concept included in the Request for Proposal (RFP). These modifications to the project features have increased the level of effort in survey and construction observation/coordination, and are based on the following items:

- The current construction duration is still estimated at approximately 16 weeks and will be completed in 2019. It is estimated that construction observation will now be required full-time (40 hours/week) through the duration of construction.
- Additional construction staking will be required due to the addition of the NW pump station.
- Additional electrical construction services will be required due to the addition of the NW pump station.
- Additional geotechnical review and construction materials testing will be required due to the addition of the NW pump station.

The total cost of the **Revised Construction Services** is \$194,907 as detailed in **Attachment 3**. This includes \$145,842 for Civil/Structural Construction Services (**Attachment 3**), \$40,855 for Geotech Construction Services/Construction Materials Testing (**Attachment 4**), and \$8,210 for Electrical Construction Services (**Attachment 5**). These services will continue to be provided on an hourly basis as per the original contract. This additional fee is estimated to cover the costs of revised Phase 1 project extents as shown in **Attachments 1 & 2**, with additional amendments required for additional work outside of these extents. The estimated cost is based on the construction duration assumption of 16 weeks.

## 3. Additional Geotechnical Design Services

An adjustment is required due to the revised project configuration as detailed below:

- The NW Pump Station will require additional geotechnical investigation, laboratory tests, and reporting be completed to determine the suitability of the soil for construction of the pump station.
- A geotechnical report was created for the previous project extents south of the drain. This report will be revised to match the current project extents.

The estimated costs of the **Additional Geotechnical Services** to be performed by Braun is \$11,599 as detailed in **Attachment 6**.

Page 4

**4. Additional Electrical Design Services**

The addition of the NW storm water lift station requires additional electrical design and construction services be provided.

The estimated costs of the **Electrical Design Services** performed by JK Engineers is \$11,316 as detailed **Attachment 5**. The construction services will be completed on an hourly basis as per the original contract.

**5. Project Closeout**

With the addition of the NW storm water lift station, the level of effort for **Project Closeout** is increased. The following items will be provided.

- Increased effort on Closeout Documents preparation
- Project Development Summary – Decisions (Structural Calculations, Interior Drainage Technical Memorandum, Geotech Report, Levee and Utility Design Summary)
- Operation and Maintenance Manual (added sections)
- Maintenance Crew Training (as necessary)

The estimated costs of **Project Closeout** is \$30,062 as detailed **Attachment 3**. The construction services will be completed on an hourly basis as per the original contract.

**Basis of Proposal**

This amendment only covers the services as described above. Specifically, the amendment includes design and completion of bid documents, construction services, and project closeout for the SE and NW Pump Station site extents as indicated in **Attachments 1 & 2**.

**Fee:**

The total estimated fee for the above described tasks is \$396,182. Additional work required beyond the scope listed above will be billed at our current hourly rates. This includes any modifications of the project extents, including re-inclusion of previously proposed flood risk management features. Houston Engineering, Inc. (with assistance from Braun Intertec, Inc. and JK Engineers) will perform the services as outlined above and detailed in the Attachments to this letter. Tasks will be performed in accordance with our current hourly rates in the year services are provided.

**Conditions:** Services will be invoiced monthly and are due and payable upon receipt.



Page 5

Limitation of Liability: Houston Engineering, Inc. agrees to indemnify and save the client harmless from any loss, cost, or expense including attorney fees, claimed by third parties for property damage or bodily injury, including death, caused by the negligence of Houston Engineering, Inc. or its employees in connection with Houston Engineering, Inc.'s services. The client agrees to indemnify and save Houston Engineering, Inc. harmless from any loss, cost, or expense, including attorney fees, claimed by third parties for property damage or bodily injury including death, caused by the negligence of the client or its employees in connection with the operations of the client. If the negligence of both Houston Engineering, Inc. and the client (or a person identified above for whom each is liable) is the cause of such damage or injury, the loss, cost, or expense shall be shared between Houston Engineering, Inc. and the client in proportion to their relative degrees of negligence and the right of indemnity shall apply for such proportion. Neither party hereto shall be liable to the other for incidental, special or indirect damages nor shall Houston Engineering, Inc. be liable for any cost or expense that provides betterment, upgrade or enhancement of the project.

Houston Engineering, Inc. hereby proposes, and the client hereby authorizes, the above described services to be performed by Houston Engineering, Inc. under the terms and conditions set forth.

Authorization:

Client: City of Fargo

Signature: \_\_\_\_\_

Title: \_\_\_\_\_

Date: \_\_\_\_\_

Proposal: Houston Engineering, Inc.

Signature: *Jerry Beust*

Title: Vice President

Date: 9/14/18



ATTACHMENT 1 – NW Pump Station Approximate Project Extents

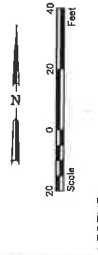
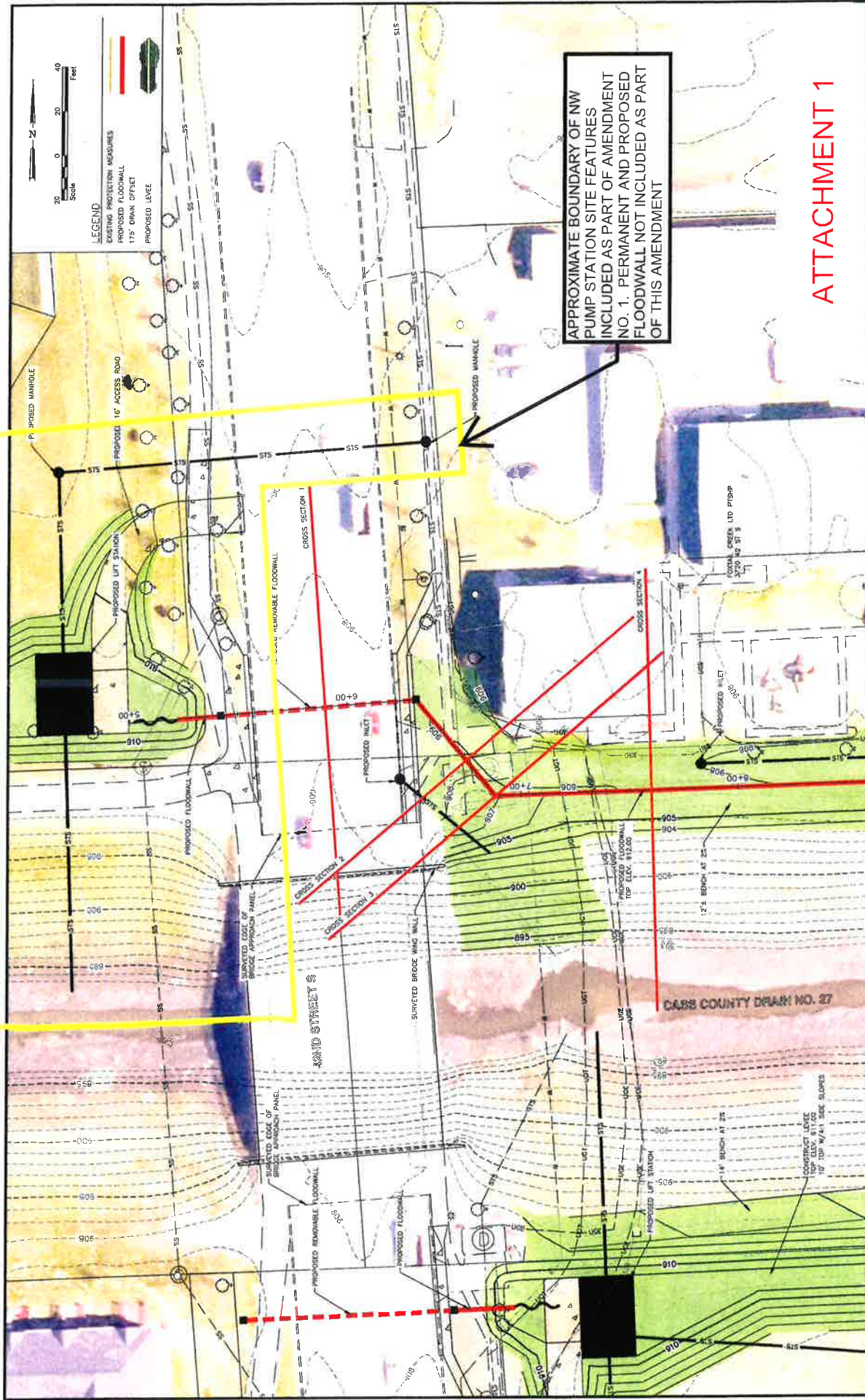

APPROXIMATE BOUNDARY OF NW PUMP STATION SITE FEATURES INCLUDED AS PART OF AMENDMENT NO. 1. PERMANENT AND PROPOSED FLOODWALL NOT INCLUDED AS PART OF THIS AMENDMENT

# ATTACHMENT 1

No.	Revision	Date	By	Houston Engineering Inc		Date: 6-25-15	Drawn by: DEK/JMW	Checked by: KAL	Scale: AS SHOWN	DRAIN 27 - 129 TO 42ND ST FLOOD MITIGATION		SHEET
				City of Fargo Project 6228						OVERALL PLAN		
				FARGO, ND		PROJECT NO. 6059-062		OPTION 2B.1		1 of 2		

M:\17618\6059-062\6059-062-13\6059-062-13.dwg: 17618.dwg: 6/25/15 10:48:27 AM

ATTACHMENT 2 – SE Pump Station Approximate Project Extents

ATTACHMENT 2

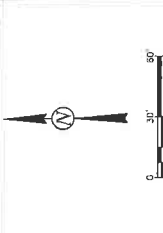
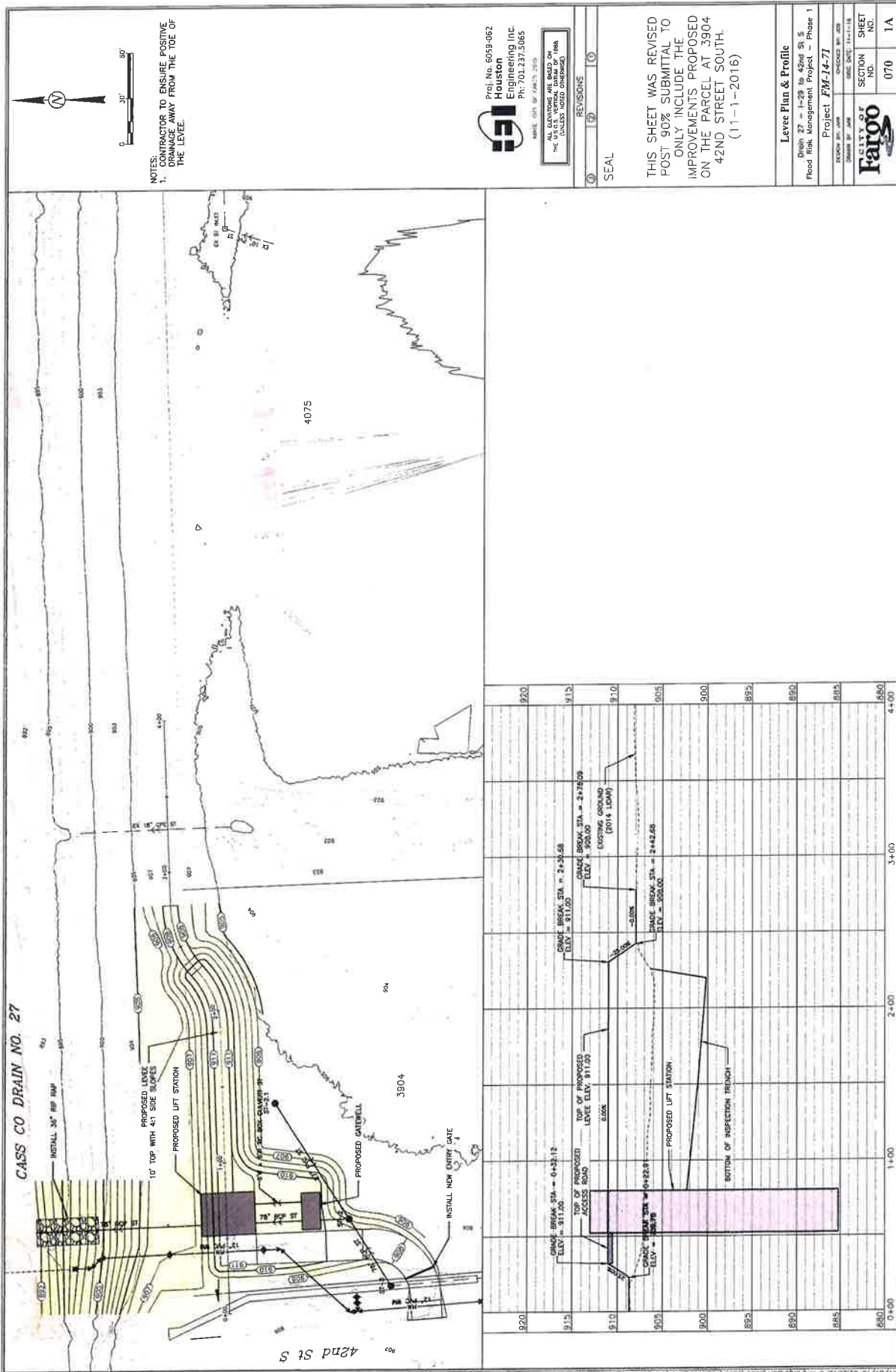

NOTES:  
 1. CONTRACTOR TO ENSURE POSITIVE DRAINAGE AWAY FROM THE TOE OF THE LEVEE.



STATE OF TEXAS  
 PROFESSIONAL ENGINEER  
 NO. 0000000000

REVISIONS

0	
1	
2	

THIS SHEET WAS REVISED POST 90% SUBMITTAL TO ONLY INCLUDE THE IMPROVEMENTS PROPOSED ON THE PARCEL AT 3904 42ND STREET SOUTH (11-1-2016)

Levee Plan & Profile

Drawn 27 - 1-29 to 42nd St S  
 Flood Risk Management Project - Phase 1  
 Project FM-14-71

DESIGNED BY: JAM	CHECKED BY: JBP
DRAWN BY: JAM	DATE: 11-1-16
<b>Fargo</b>	
SECTION NO.	SHEET NO.
070	1A

11/01/16 02:06:49pm H:\eng\jerry\2016\02\11\_6059\_062\F&I\13\_6059\_062\CAD\Drawings\Levee Plan & Profile - The Office 10-31-16.dwg

**ATTACHMENT 3 – Revised Design Services, Construction Services, and Closeout Services**





Task	Description	From JK	Hours	Rate	Cost	Start	End	Days	Notes
Complete Hydraulic Design Including Interior Drainage Analysis. Provide Technical Memorandum.	Structural Analysis - Pump Station		8						
	Structural Analysis - Gatewell		4						
	Electrical Design								
	Public Utility Design and Relocation Plans		1						
	Private Utility Relocation Planning and Coordination		1						
	Civil Site Design/Paving		32						
	Erosion Control Plans		2						
	Traffic Control Plans		2						
	Special Instructions to Bidders		2						
	Develop Pay Items and Engineers Opinion of Probable Construction Costs		4						
Right-of-way Determination and Exhibit Creation. Includes Property Descriptions		1							
Prepare permit application: SECWRI/INDDOH		1							
Support During Bidding. Answer Bidder Questions, Etc...		2							
Total Hours		28							
Total Costs		\$5,488							
\$120,632									
<b>TASK 4 - CONSTRUCTION</b>									
Subtask 4.1 - Construction Administration									
Submittal Review & responding to Contractor RFI's		2							
Coordination with utility companies		4							
Project administration		10							
Construction Progress Reports (Bi-Weekly)		10							
Progress Payments and Enter Quantities into City's Software (Monthly)		2							
RPR Services		2							
Change Management		8							
Electrical Construction Services		8							
Construction Staking		2							
Construction Materials Testing		2							
Construction Materials Testing		2							
Subtask 4.3 - Project Closeout									
Final Inspection and Closeout Certification to City		2							
Warranty Inspection and Report		2							
Design Decision Tech Memo (Based on As-Constructed Condition) - Includes Structural Calculations, Interior Drainage Documentation, Geotechnical Report, Levee/Utility Design and Summary.		4							
Stormwater Permit Termination		2							
Operations and Maintenance Manuals		2							
Prepare Record Drawings		2							
Supply Project Files in Electronic Format to City (CAD & SWMM)		2							
Maintenance Staff Training		4							
Total Hours		44							
Total Costs		\$8,624							
\$224,969									
Total Project Costs									
Total Hours		89							
Total Costs		\$17,444							
\$396,182									
\$396,182									

Summary OVERALL PROJECT ADMINISTRATION Cost \$10,364

CIVIL/STRUCTURAL PRELIMINARY DESIGN (30% NORTH SIDE)	\$28,618
FINAL DESIGN AND PLAN PREPARATION (90%/100%)	\$109,316
<b>Additional Design Phase Services =</b>	<b>\$148,298</b>
GEOTECH - CONSTRUCTION MATERIALS TESTING	\$40,855
ELECTRICAL CONSTRUCTION	\$8,210
CIVIL/STRUCTURAL CONSTRUCTION	\$145,842
<b>Revised Construction Services =</b>	<b>\$194,907</b>
<b>Additional Geotechnical Design Services =</b>	<b>\$11,599</b>
<b>Additional Electrical Design Services =</b>	<b>\$11,316</b>
<b>Project Closeout</b>	<b>\$30,062</b>
<b>Amendment 1 Total =</b>	<b>\$396,182</b>



## ATTACHMENT 4 – Revised Geotechnical Construction Services



# Project Draft Proposal

FM-14-71 (Phase 2 - NW Lift Station)

**Client:**

Mr. Gabe Bladow, PE  
Houston Engineering, Inc.  
1401 21st Ave N  
Fargo, ND 58102

**Work Site Address:**

Drain 27  
North of Drain 27 & West of 42nd St S  
I-29 to 42nd St S  
Fargo, ND

**Service Description:**

Construcion Materials Testing and Observations

**Project Manager:** Matthew Haugstad

Description		Quanti	Units	Unit Price	Extension
<b>Phase 2 Construction Materials Testing</b>					
<b>Activity 2.1</b>	<b>Soils Observations and Testing</b>				<b>\$6,537.00</b>
206	Excavation Observations	7.00	Hour	106.00	\$742.00
	<i>Work Activity Detail</i>	<i>Qty</i>	<i>Units</i>	<i>Hrs/Unit</i>	<i>Extension</i>
	Levee Excavation	1.00	Trips	3.00	3.00
	Lift Station Excavation	1.00	Trips	4.00	4.00
207	Compaction Testing - Nuclear	36.00	Hour	81.00	\$2,916.00
	<i>Work Activity Detail</i>	<i>Qty</i>	<i>Units</i>	<i>Hrs/Unit</i>	<i>Extension</i>
	Levee Inspection Trench	5.00	Trips	1.50	7.50
	Levee Embankment	3.00	Trips	1.50	4.50
	Driveway	2.00	Trips	1.50	3.00
	Lift Station Backfill	14.00	Trips	1.50	21.00
209	Sample pick-up	3.00	Hour	81.00	\$243.00
1308	Nuclear moisture-density meter charge, per hour	36.00	Each	23.00	\$828.00
1156	Atterberg Limits: LL and PL (ASTM D 4318), per sample	2.00	Each	111.00	\$222.00
1162	Sieve analysis with 200 wash (ASTM C 136 and C 177), per sample	1.00	Each	136.00	\$136.00
1166	200 wash (ASTM C 117), per sample	2.00	Each	76.00	\$152.00
1318	Standard Proctor Test(ASTM D 698)	3.00	Each	191.00	\$573.00
1861	CMT Trip Charge	29.00	Each	25.00	\$725.00
<b>Activity 2.2</b>	<b>Concrete Testing</b>				<b>\$6,233.00</b>
1861	CMT Trip Charge	23.00	Each	25.00	\$575.00
261	Concrete Testing	32.00	Hour	81.00	\$2,592.00
	<i>Work Activity Detail</i>	<i>Qty</i>	<i>Units</i>	<i>Hrs/Unit</i>	<i>Extension</i>
	Mud Slab	2.00	Trips	2.00	4.00
	NW Lift Station Walls	8.00	Trips	2.00	16.00
	NW Lift Station Slabs	2.00	Trips	3.00	6.00
	Paving and Driveways	2.00	Trips	2.00	4.00
	Sidewalks and Curb & Gutter	1.00	Trips	2.00	2.00
1369	Compressive strength of 4 x 8" concrete cylinders (ASTM C 39	78.00	Each	31.00	\$2,418.00
	<i>Work Activity Detail</i>	<i>Qty</i>	<i>Units</i>	<i>Hrs/Unit</i>	<i>Extension</i>
	Mud Slab	2.00	Trips	3.00	6.00
	NW Lift Station Walls	8.00	Set	5.00	40.00
	NW Lift Station Slabs	4.00	Set	5.00	20.00
	Paving and Driveways	2.00	Set	4.00	8.00
	Sidewalks and Curb & Gutter	1.00	Set	4.00	4.00
278	Concrete Cylinder Pick up	8.00	Hour	81.00	\$648.00
<b>Activity 2.3</b>	<b>Certification Letter</b>				<b>\$1,168.00</b>
126	Project Engineer	4.00	Hour	167.00	\$668.00
128	Senior Engineer	2.00	Hour	187.00	\$374.00
238	Project Assistant	1.50	Hour	84.00	\$126.00



# Project Draft Proposal

FM-14-71 (Phase 2 - NW Lift Station)

---

<b>Activity 2.4</b>	<b>Project Management and Oversight</b>			<b>\$3,310.00</b>
226	Project Manager	14.00 Hour	141.00	\$1,974.00
128	Senior Engineer	4.00 Hour	187.00	\$748.00
238	Project Assistant	7.00 Hour	84.00	\$588.00
				<b>\$17,248.00</b>
<b>Project Total</b>				<b>\$17,248.00</b>

---



The Science You Build On.

# Project Draft Proposal

FM-14-71 (Phase 1 - SE Lift Station)

**Client:**

Mr. Gabe Bladow, PE  
Houston Engineering, Inc.  
1401 21st Ave N  
Fargo, ND 58102

**Work Site Address:**

Drain 27  
South of Drain 27 & East of 42nd St S  
I-29 to 42nd St S  
Fargo, ND

**Service Description:**

Construction Materials Testing and  
Observations

**Project Manager:** Matthew Haugstad

	Description	Quantity	Units	Unit Price	Extension
<b>Phase 1</b>	<b>Construction Materials Testing</b>				
<b>Activity 1.1</b>	<b>Soils Observations and Testing</b>				<b>\$8,194.00</b>
206	Excavation Observations	11.00	Hour	106.00	\$1,166.00
	<i>Work Activity Detail</i>	<i>Qty</i>	<i>Units</i>	<i>Hrs/Unit</i>	<i>Extension</i>
	Levee Excavation	1.00	Trips	3.00	3.00
	Lift Station Excavation	1.00	Trips	4.00	4.00
	Gatewell Excavation	1.00	Trips	4.00	4.00
207	Compaction Testing - Nuclear	42.00	Hour	81.00	\$3,402.00
	<i>Work Activity Detail</i>	<i>Qty</i>	<i>Units</i>	<i>Hrs/Unit</i>	<i>Extension</i>
	Levee Inspection Trench	5.00	Trips	1.50	7.50
	Levee Embankment	3.00	Trips	1.50	4.50
	Driveway	2.00	Trips	1.50	3.00
	Lift Station Backfill	10.00	Trips	1.50	15.00
	Gatewell Backfill	8.00	Trips	1.50	12.00
209	Sample pick-up	4.00	Hour	81.00	\$324.00
1308	Nuclear moisture-density meter charge, per hour	42.00	Each	23.00	\$966.00
1156	Atterberg Limits: LL and PL (ASTM D 4318), per sample	3.00	Each	111.00	\$333.00
1162	Sieve analysis with 200 wash (ASTM C 136 and C 177), per sample	1.00	Each	136.00	\$136.00
1166	200 wash (ASTM C 117), per sample	3.00	Each	76.00	\$228.00
1318	Standard Proctor Test (ASTM D 698)	4.00	Each	191.00	\$764.00
1861	CMT Trip Charge	35.00	Each	25.00	\$875.00
<b>Activity 1.2</b>	<b>Concrete Testing</b>				<b>\$9,673.00</b>
1861	CMT Trip Charge	36.00	Each	25.00	\$900.00
261	Concrete Testing	50.00	Hour	81.00	\$4,050.00
	<i>Work Activity Detail</i>	<i>Qty</i>	<i>Units</i>	<i>Hrs/Unit</i>	<i>Extension</i>
	Mud Slabs	3.00	Trips	2.00	6.00
	SE Lift Station Walls	9.00	Trips	2.00	18.00
	SE Lift Station Slabs	2.00	Trips	3.00	6.00
	Gatewell Walls	5.00	Set	2.00	10.00
	Gatewell Slabs	2.00	Set	2.00	4.00
	Paving and Driveway	2.00	Trips	2.00	4.00
	Sidewalks and Curb & Gutter	1.00	Trips	2.00	2.00
1369	Compressive strength of 4 x 8" concrete cylinders (ASTM C 39)	121.00	Each	31.00	\$3,751.00
	<i>Work Activity Detail</i>	<i>Qty</i>	<i>Units</i>	<i>Hrs/Unit</i>	<i>Extension</i>
	Mud Slab	3.00	Trips	3.00	9.00
	SE Lift Station Walls	9.00	Set	5.00	45.00
	SE Lift Station Slabs	4.00	Set	5.00	20.00
	Gatewell Walls	5.00	Set	5.00	25.00
	Gatewell Slabs	2.00	Set	5.00	10.00
	Paving and Driveway	2.00	Set	4.00	8.00
	Sidewalks and Curb & Gutter	1.00	Set	4.00	4.00
278	Concrete Cylinder Pick up	12.00	Hour	81.00	\$972.00



# Project Draft Proposal

FM-14-71 (Phase 1 - SE Lift Station)

<b>Activity 1.3</b>	<b>Certification Letter</b>			<b>\$1,522.00</b>
126	Project Engineer	5.00 Hour	167.00	\$835.00
128	Senior Engineer	3.00 Hour	187.00	\$561.00
238	Project Assistant	1.50 Hour	84.00	\$126.00
<b>Activity 1.4</b>	<b>Project Management and Oversight</b>			<b>\$4,218.00</b>
226	Project Manager	16.00 Hour	141.00	\$2,256.00
128	Senior Engineer	6.00 Hour	187.00	\$1,122.00
238	Project Assistant	10.00 Hour	84.00	\$840.00
				<b>\$23,607.00</b>
<b>Project Total</b>				<b>\$23,607.00</b>

## ATTACHMENT 5 – Revised Electrical Services

# Engineering Services Estimate Summary

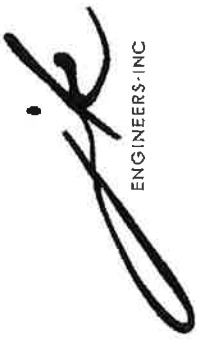

Project No. 18-008 By: JAK Date Prepared: September 6, 2018

Project Title: **Twin Lift Stations - 42nd Street and Drain 27**  
**City of Fargo 6059-062**  
**Fargo, ND**

**Project Description:**

Provide Electrical Engineering Services for Two Flood Pump Stations along 42st South and Drain 27. Preliminary Design of the Station south of Drain 27 was performed in 2016. This project to consist of finalizing the design of the south side station and providing a new design for the station on the north side of Drain 27.

**Engineering Deliverables**

- I. Preliminary Designs, Submittals and Review
  - II. Final Design, Construction Documents and Bidding Assistance
  - III. Construction Phase Services
- Services will be provided to as a subconsultant to Houston Engineering.

**Engineering Deliverables**

	Cost
I. Preliminary Design Submittals and Review	\$4,608.00
II. Final (100%) Design	\$6,708.00
III. Construction Phase Services	\$8,210.00

<b>Total Estimated Services</b>	<b>\$19,526.00</b>
---------------------------------	--------------------

# Engineering Services Estimate

Project No. 18-008 Date Prepared: #####  
 By: JAK

Project Title: **Twin Lift Stations - 42nd Street and Drain 27**  
**City of Fargo 6059-062**

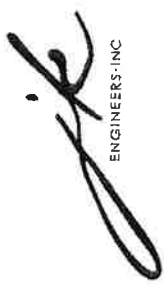

Phase: **I. Preliminary Design Submittals and Review**

Phase Tasks	Hours				
	Principal	Senior Eng.	Eng I	Tech	CADD
1 A. MEETINGS AND COORDINATION	8				
2					
3 B. PRELIMINARY PLANS AND SPECIFICATIONS					
4 PLANS	4	8			8
5 TECHNICAL SPECIFICATIONS (using City of Fargo Standard SIB)	2	2			
6					
7					
8 C. ENGINEERS REPORT		8			
9					
10					
11					
12					
13					
14					
15					

**Fee Calculation:**

Hours	Rate	Total
Principal 14	\$125.00 /Hour	\$1,750.00
Senior Eng. 18	\$105.00 /Hour	\$1,890.00
Eng I 0	\$95.00 /Hour	\$0.00
Tech 0	\$80.00 /Hour	\$0.00
CADD 8	\$75.00 /Hour	\$600.00
Clerical 4	\$42.00 /Hour	\$168.00
<b>Total Fee</b>		<b>\$4,408.00</b>

**Expense Calculation:**

Category	Units	Rate	Total
Airline Travel	Days	\$46.00 /Day	\$0.00
Per Diem	Days	\$89.00 /Day	\$0.00
Motel	Miles	\$0.55 /Mi	\$0.00
Mileage			
Printing			\$200.00
Phone			\$0.00
Miscellaneous			\$0.00

**I. Preliminary Design Submittals and Review**

**Total Estimated Fees and Expenses: \$4,608.00**

**Total Expense \$200.00**



# Engineering Services Estimate

Project No. 18-008 By: JAK Date Prepared: #####

Project Title: **Twin Lift Stations - 42nd Street and Drain 27**  
**City of Fargo 6059-062**



Phase: **II. Final (100%) Design**

	Phase Tasks	Hours				
		Principal	Senior Eng.	Eng I	Tech	CADD
1	A. MEETINGS AND COORDINATION	4				
2						
3	B. FINAL PLANS AND SPECIFICATIONS					
4	PLANS	4	12			20
5	TECHNICAL SPECIFICATIONS (using City of Fargo Standard SIB)	8	8			
6						
7	BIDDING ASSISTANCE ADDENDA PREPARATION	4		2		2
8						
9						
10						
11						
12						
13						
14						
15						

**Fee Calculation:**

	Hours	Rate	Total
Principal	20	\$125.00 /Hour	\$2,500.00
Senior Eng.	20	\$105.00 /Hour	\$2,100.00
Eng I	2	\$95.00 /Hour	\$190.00
Tech	0	\$80.00 /Hour	\$0.00
CADD	22	\$75.00 /Hour	\$1,650.00
Clerical	4	\$42.00 /Hour	\$168.00
<b>Total Fee</b>			<b>\$6,608.00</b>

**Expense Calculation:**

			Total
Airline Travel		/Trip	\$0.00
Per Diem	Days	\$46.00 /Day	\$0.00
Motel	Days	\$89.00 /Day	\$0.00
Mileage	Miles	\$0.55 /Mi	\$0.00
Printing			\$100.00
Phone			\$0.00
Miscellaneous			\$0.00

<b>II. Final (100%) Design</b>	
<b>Total Estimated Fees and Expenses:</b>	<b>\$6,708.00</b>

**Total Expense**

**\$100.00**

# Engineering Services Estimate

Project No. 18-008 By: JAK Date Prepared: #####

Project Title: **Twin Lift Stations - 42nd Street and Drain 27**  
**City of Fargo 6059-062**

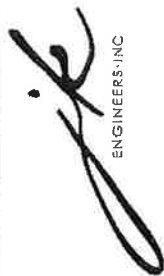

Phase: **II. Construction Phase Services**

	Phase Tasks	Hours				
		Principal	Senior Eng.	Eng I	Inspection	CADD
1						
2	A. OFFICE - CONSTRUCTION PHASE ADMINISTRATION 12 wk @ 1 hr/wk		12			
3						
4						
5	B. SHOP DRAWING REVIEW		8			
6						
7	C. INSPECTIONS AND FINAL INSPECTION		8		40	
8						
9	D. RECORD DRAWINGS		2			8
10						
11						
12						
13						
14						
15						

**Fee Calculation:**

	Hours	Rate	Total
Principal	16	\$125.00 /Hour	\$2,000.00
Senior Eng.	22	\$105.00 /Hour	\$2,310.00
Eng I	0	\$95.00 /Hour	\$0.00
Inspection	40	\$80.00 /Hour	\$3,200.00
CADD	8	\$75.00 /Hour	\$600.00
Clerical	0	\$42.00 /Hour	\$0.00
<b>Total Fee</b>			<b>\$8,110.00</b>

**Expense Calculation:**

			Total
Airline Travel			\$0.00
Per Diem	Days	\$46.00 /Day	\$0.00
Motel	Days	\$89.00 /Day	\$0.00
Mileage	Miles	\$0.55 /Mi	\$0.00
Printing			\$100.00
Phone			\$0.00
Miscellaneous			\$0.00

**II. Construction Phase Services**  
**Total Estimated Fees and Expenses: \$8,210.00**

**Total Expense \$100.00**

## ATTACHMENT 6 – Additional Geotechnical Design Services

**Braun Design Services Estimate**

Fieldwork					
292	Drilling Supervisor	Hrs	0	\$ 129	\$ -
128	Senior Engineer	Hrs	3	\$ 214	\$ 642.00
9100	Flotation Tire Drill Rig	Hrs	6	\$ 328	\$ 1,968.00
1022	Thin-Walled Sample Tubes	Ea	4	\$ 32	\$ 128.00
9732	Grout with Neat Cement	Ft	60	\$ 8	\$ 480.00
PERDIEM	Per Diem	Ea	0	\$ 250	\$ -
					<b>\$ 3,218.00</b>
Laboratory Testing					
1152	Moisture Content	Ea	4	\$ 22	\$ 88.00
1154	Moisture-Density	Ea	4	\$ 39	\$ 156.00
1156	Atterberg Limits	Ea	4	\$ 123	\$ 492.00
1166	Mechanical Analysis (#200 Only)	Ea	0	\$ 84	\$ -
1318	Standard Proctor	Ea	0	\$ 212	\$ -
1192	Direct Shear (cohesive)	Ea	0	\$ 881	\$ -
1186	Unconfined Compression	Ea	4	\$ 106	\$ 424.00
1208	CU Triaxial Shear w/PWP	Ea	0	\$ 1,450	\$ -
					<b>\$ 1,160.00</b>
Engineering					
126	Project Engineer	Hrs	0	\$ 191	\$ -
128	Senior Engineer	Hrs	32	\$ 214	\$ 6,848.00
130	Principal Engineer	Hrs	3	\$ 259	\$ 777.00
138	Project Assistant	Hrs	3	\$ 104	\$ 312.00
226	Project Manager	Hrs	3	\$ 191	\$ 573.00
					<b>\$ 8,510.00</b>
					<b>\$ 12,888.00</b>
					<b>\$ 11,599.20</b>

REPORT OF ACTION

36

**UTILITY COMMITTEE**

Project No. WA1753

Type: Bid Award – WTP Filter To Waste Installation

Location: Water Treatment Plant

Date of Hearing: 10/4/18

<u>Routing</u>	<u>Date</u>
City Commission	10/8/18
Project File	

Troy Hall, Water Utility Director, presented the attached memorandum related bid award for Project WA1753 – Filter-to-Waste Installation. This project has been strongly encouraged by the North Dakota Department of Health as an operational protection to comply with EPA-mandated filter regulations. The bids for the General Contract and Electrical Contract totaled \$717,000. Engineer's estimate was \$844,000. The bids are 15.0% under engineers estimate. Please see letter, titled 'Engineer's Review and Award Recommendation. Filter-to-Waste installation was a recommendation in the Phase 2 Facility Plan for the Water Treatment Plant.

Water Utility staff requests that this project be paid through State Revolving Fund (SRF) loan. The SRF loan has already been approved by the North Dakota Industrial Commission.

**MOTION:**

On a motion by Kent Costin, seconded by Brenda Derrig, the Utility Committee voted to approve the bid award with Northern Plains Contracting for the General Contract in the amount of \$681,000 and Sun Electric, Inc. the Electrical Contract in the amount of \$36,000.

<u>COMMITTEE:</u>	<u>Present</u>	<u>Yes</u>	<u>No</u>	<u>Unanimous</u>
				<u>X</u>
				<u>Proxy</u>
Anthony Gehrig, City Commissioner				
Kent Costin, Director of Finance	X			
Brian Ward, Water Plant Supt.	X			
Mark Miller, Wastewater Plant Supt.				
Bruce Grubb, City Administrator	X			
Scott Liudahl, City Forester	X			
Terry Ludlum, Solid Waste Utility Director	X			
James Hausauer, Wastewater Util. Director	X			
Troy Hall, Water Utility Director	X			
Ben Dow, Public Works Operations Director	X			
Brenda Derrig, City Engineer	X			

ATTEST:

  
 \_\_\_\_\_  
 Troy B. Hall  
 Water Utility Director

C: Tim Mahoney, Mayor  
 Commissioner Strand  
 Commissioner Piepkorn  
 Commissioner Grindberg



**Water Treatment Plant**  
 435 14th Avenue South  
 Fargo, ND 58103  
 Office: 701.241.1469 | Fax: 701.241.8110  
[www.FargoND.gov](http://www.FargoND.gov)

## MEMORANDUM

October 2, 2018

---

**To:** Utility Committee

**From:** Troy B. Hall, Water Utility Director *TBH*

**Re:** Bid Award – WTP Filter-to-Waste Improvements, Project WA1753

---

### Introduction

Construction bids were opened at 11:30 AM, local time, on Wednesday, September 19, 2018, for Project WA1753, Fargo WTP Filter-to-Waste Improvements. Please see attached letter of Engineer's Bid Review and Award Recommendation.

Five (5) bids were received for Contract No. 1 – General Construction. Two (2) bids were received for Contract No. 2 – Electrical Construction. Two (2) bids were received for Contract No. 3 – Combined Construction. All bids complied with all North Dakota Century Code (NDCC) and State Revolving Fund (SRF) loan requirements. Water Utility Staff is recommending award to the lowest bidders: Northern Plains Contracting for Contract No. 1 and Sun Electric, Inc. for Contract No. 2.

There was a bid alternate to update electric actuators for the filter air-scour system, which are original to the Water Treatment Plant (WTP). The actuators were recommended for replacement in the Phase 2 Facility Plan for the WTP. Water Utility Staff is recommending accepting bid alternate for the actuators.

The total recommended bid price for the project is \$717,000 for both contracts. This includes the actuators as a bid alternate. The Engineer's estimate for this work was \$844,000. The lowest bid (plus alternates) was 15.0 percent below the estimate.

### Plan of Financing

It is suggested that the funding for the Filter-to-Waste installation come from a State Revolving Fund (SRF) loan. The SRF loan was approved by the North Dakota Industrial Commission in March, 2018. Filter-to-Waste was a planned line item in the 2017 budget called 'Existing WTP Upgrades'.

### **SUGGESTED MOTION:**

Award bids for Project WA1753 (WTP Filter-to-Waste Improvements) to Northern Plains Contracting for Contract No. 1 in the amount of \$681,000 and Sun Electric, Inc. for Contract No. 2 in the amount of \$36,000.

Your consideration in this matter is greatly appreciated.





9/27/2018

Mr. Troy Hall  
Water Utility Director  
City of Fargo  
435 14th Ave S  
Fargo ND 58103-4306

**Re: Fargo WTP Filter-to-Waste Improvements  
Engineer's Bid Review and Award Recommendation  
Fargo Water Project #WA1753**

Dear Mr. Hall:

Bids were received at 11:30 a.m. on Wednesday, September 19, 2018 at the City Auditor's Office and opened immediately following in the Meadowlark Room at the Fargo City Hall for the above referenced project. A total of seven (7) different bidders submitted a total of seven (7) sealed bids. Each of the bids that were submitted met all of the prescribed requirements and were opened and read aloud. This letter summarizes the bid results received and includes the Engineer's recommendation for award. Please note that the award is contingent upon approval from the North Dakota Department of Health due to the requirements of the Drinking Water State Revolving Fund (DWSRF) Program.

The project was bid as three (3) separate contracts. Individual bids were received for Contract No. 1 – General Construction and Contract No. 2 – Electrical Construction. Additionally, a combined bid for the work under these two individual contracts was bid under Contract No. 3 – Combined General and Electrical Construction. Please note that a combined bid should not be accepted unless that bid is lower than the combined total of the lowest, responsible bids for the individual contracts. Each individual contract also included a bid alternate associated with the replacement of existing electric valve actuators. A bid tabulation is attached to this letter for your review.

The recommendations to award or decline each low, responsible bid and bid alternate are presented below based on correspondence held with you following the conclusion of the bid opening. Based on a review of the base bids, the apparent low base bid is comprised of Northern Plains Contracting for the general construction (Contract No. 1) and Sun Electric, Inc. for the electrical construction (Contract No. 2). As such, the project team recommends the following construction contracts and bid alternates:

- Contract No. 1 – General Construction and Alternate for Contract No. 1: Northern Plains Contracting in the amount of \$681,000.00.
- Contract No. 2 – Electrical Construction and Alternate for Contract No. 2: Sun Electric, Inc. in the amount of \$36,000.00.

**Based on the bid results, the total bid price for the project (including the bid alternates) is \$717,000.00.**

Mr. Troy Hall  
Water Utility Director

**Re: Fargo WTP Filter-to-Waste Improvements  
Engineer's Bid Review and Award Recommendation  
Fargo Water Project #WA1753**

9/27/2018

Page 2 of 2

Thank you for the opportunity to assist the City of Fargo with this important project. Should you have any comments or questions regarding the bid results or the project in general, please do not hesitate to contact me at (701) 364-9111.

Respectfully Submitted,

AE2S

A handwritten signature in blue ink, appearing to read "Ryan Grubb".

Ryan Grubb, PE  
Project Engineer

Attachments



Tabulation of Bids  
 WTP Filter-to-Waste Improvements  
 Fargo, ND  
 P00803-2017-008, City Project No. WA1753  
 Bid Opening 11:30 AM, September 19, 2018

Contractor	Acknowledge Addendum 1	Bid Bond	Contractor's License	MBE/WBE Subcontractor Solicitation Info	Certification Regarding Debarment	Bid Form	Contract No. 1 - General Construction	Alternate for Contract No. 1	Contract No. 2 - Electrical Construction	Alternate for Contract No. 2	Contract No. 3 - Combined Construction	Alternate for Contract No. 3
1 Northern Plains Contracting	✓	✓	✓	✓	✓	✓	\$615,000.00	\$65,000.00	NO BID	NO BID	\$64,500.00	\$65,000.00
2 PKG Contracting, Inc.	✓	✓	✓	✓	✓	✓	\$646,900.00	\$64,000.00	NO BID	NO BID	\$83,569.00	\$65,069.00
3 Shank Constructors, Inc.	✓	✓	✓	✓	✓	✓	\$653,700.00	\$64,800.00	NO BID	NO BID	NO BID	NO BID
4 CC Steel, LLC	✓	✓	✓	✓	✓	✓	\$755,700.00	\$309,700.00	NO BID	NO BID	NO BID	NO BID
5 Swanberg Construction, Inc.	✓	✓	✓	✓	✓	✓	\$694,000.00	\$41,000.00	NO BID	NO BID	NO BID	NO BID
6 Sun Electric, Inc.	✓	✓	✓	✓	✓	✓	NO BID	NO BID	\$34,000.00	\$2,000.00	NO BID	NO BID
7 JDP Electric, Inc.	✓	✓	✓	✓	✓	✓	NO BID	NO BID	\$47,990.00	\$1,420.00	NO BID	NO BID
Engineer's Estimate							\$740,000.00	\$70,000.00	\$30,000.00	\$4,000.00	\$765,000.00	\$74,000.00

Respectfully Submitted by:

  
 Ryan Grubb, PE



Advanced Engineering and Environmental Services, Inc.  
 4170 28th Ave S  
 Fargo, ND 58104  
 Tel: 701-364-9111  
 Fax: 701-364-9979

REPORT OF ACTION

37

**UTILITY COMMITTEE**

Project No. N/A

Type: Sole Source – Hydro Klean  
Clean WTP Piping

Location: Water Treatment Plant

Date of Hearing: 10/4/18

<u>Routing</u>	<u>Date</u>
City Commission	10/8/18
Project File	

Troy Hall, Water Utility Director, presented the attached memorandum related to sole sourcing cleaning piping between the primary softening basins and secondary softening basins. This cleaning will occur in softening trains #1 and #3 and bring those trains back up to full capacity. Since the piping is deep below the Water Treatment Plant (WTP) and difficult to access, specialty contractors are required for the project. Upon research, there are a limited number of contractors nation-wide. Hydro Klean worked on softening train #2 early in 2018 with good results.

Water Utility staff requests that this project be paid with Fund 450 – Infrastructure Sales Tax. There is a line item called Rehab and Renewal in the 2018 budget that this project fits under well.

**MOTION:**

On a motion by Brenda Derrig, seconded by Jim Hausauer, the Utility Committee voted to approve the sole source with Hydro Klean for cleaning Water Plant piping in the amount of \$68,000.

<u>COMMITTEE:</u>	<u>Present</u>	<u>Yes</u>	<u>No</u>	<u>Unanimous</u>
				X
				Proxy
Anthony Gehrig, City Commissioner				
Kent Costin, Director of Finance	X			
Brian Ward, Water Plant Supt.	X			
Mark Miller, Wastewater Plant Supt.				
Bruce Grubb, City Administrator	X			
Scott Liudahl, City Forester	X			
Terry Ludlum, Solid Waste Utility Director	X			
James Hausauer, Wastewater Util. Director	X			
Troy Hall, Water Utility Director	X			
Ben Dow, Public Works Operations Director	X			
Brenda Derrig, City Engineer	X			

ATTEST:

  
\_\_\_\_\_  
Troy B. Hall  
Water Utility Director

C: Tim Mahoney, Mayor  
Commissioner Strand  
Commissioner Piepkorn  
Commissioner Grindberg

**MEMORANDUM**

October 2, 2018

---

**To:** Utility Committee

**From:** Troy B. Hall, Water Utility Director *TBH*

**Re:** Sole Source – Hydro Klean for WTP Softening Basin Pipe Cleaning

---

Please see the attached proposal with Hydro Klean in the amount of \$68,000 to clean scale in pipes that connect the primary and secondary softening basins for two softening trains in the Water Treatment Plant (WTP). Water Utility staff is recommending a sole source with Hydro Klean because this work requires specialty equipment and services provided by only a few contractors nation-wide. Hydro Klean is the only one in our region to provide a proposal. Funding for this sole source request would be paid through Fund 450 (Infrastructure Sales Tax). There is a Rehab and Renewal line in the 2018 approved budget to cover this work.



**42-inch Pipe showing scale buildup in Softening Train #2. This pipe is deep under the Water Treatment Plant and was cleaned by Hydro Klean this past spring.**

Scaling in the pipes between the primary and secondary softening basin is providing a bottleneck and restricting flow in the water treatment plant. Hydro Klean cleaned one of the three softening train pipes this past spring to allow water production in the summer of 2018 without imposing mandatory water use restrictions to customers. Water Utility staff is recommending finishing the other two pipes this fall. The invoice to remove scale from Softening Train #2 was \$43,500. The current proposal reflects cleaning Softening Trains #1 and #3 in the same trip to reduce some cost.

**SUGGESTED MOTION:**

Approve sole source with Hydro Klean in the amount of \$68,000 to remove scale from softening train pipes.

Your consideration in this matter is greatly appreciated.



Des Moines, IA

Mankato, MN

Rogers, MN

Sioux Falls, SD

Watertown, SD

Bovey, MN

Kansas City, KS

Wausau, WI

# PROPOSAL

Bill To: City of Fargo Water Treatment Plant  
435 14Th Ave South  
Fargo, ND 58103

Ship To: City of Fargo Water Treatment Plant  
435 14Th Ave South  
Fargo, ND 58103

Date	Expires
9/11/2018	11/10/2018
Hydro-Klean Quote Number	Delivery / Availability
QTE042145	As Schedule Permits
Prepared By	
John Bluntach	
Freight On Board	
Terms	
Net 30	

Quantity	Units	Description	Price	Amount
----------	-------	-------------	-------	--------

Projected probable project cost to perform the following tasks on a unit cost basis: Cleaning of 90 feet of 54" pipes to leading to softening basins. Both sections of pipe will be cleaned consecutively. Variations in the work scope will require execution of a change order.

2.00	Each	Removing Mineral Deposits from 90' of 54" Pipe Leading to Softening Basin	\$34,000.00	\$68,000.00
------	------	---	-------------	-------------

\*NOTE: Proposal does not include any applicable taxes

Prepared By: John Bluntach  
 Approved By: Wade Anderson  
 Accepted By: \_\_\_\_\_  
 Title: \_\_\_\_\_

Title: Account Manager  
 Title: President  
 Date: \_\_\_\_\_  
 PO#: \_\_\_\_\_

*Total
\$68,000.00



REPORT OF ACTIONUTILITY COMMITTEE

38

Project No. WA1301

Type: Project WA1301 Change  
Orders – General Contract

Location: Water Treatment Plant Expansion

Date of Hearing: 10/4/18

<u>Routing</u>	<u>Date</u>
City Commission	10/8/18
Project File	

Troy Hall, Water Utility Director, presented the attached memo related to change orders for Membrane Water Treatment Plant (MWTP) construction with Alberici Constructors, Inc. (ACI), the General Contractor. The total proposed cost increase is \$181,730. In the change order proposals, there are 13 listed changes. The highest cost item relates to compressed air system changes to operate pneumatic valves. Overall, Water Utility staff suggests that the MWTP construction project is going well. Currently, plant startup is continuing and finished water from the new plant will be delivered to customers soon.

Water Utility staff thinks that all of the changes are in the best long-term interest of the City of Fargo. The overall status of cost change orders was discussed at the Utility Committee meeting for MWTP construction. After some research inquiring about comparable projects, Water Utility staff suggests that the industry average for cost change orders is an increase of about 3% to 5% of the bid price at completion. If the currently proposed contract changes are approved, the cost change orders for the MWTP will total an increase of 4.55% from the original bid price. However, only 3.23% is attributed to errors/omissions and other minor changes typical in a construction project. The other 1.32% of changes were implemented related to capacity increases with West Fargo water service and a project contribution from Black & Veatch. Water Utility staff also suggests that we are at a reasonable level for overall cost change orders at this point and are nearing the end of construction.

After bidding, contracts were approved on April 27, 2015, for Membrane Water Treatment Plant (MWTP) construction to the three prime contractors as follows:

<u>Contract</u>	<u>Contractor</u>	<u>Bid Price</u>
No. 1 – General Construction	Alberici Constructors, Inc.	\$80,044,884.00
No. 2 – Mechanical Construction	Wrigley Mechanical, Inc.	\$6,824,000.00
No. 3 – Electrical Construction	JDP Electric, Inc.	\$16,821,411.00
<b>TOTAL</b>		<b>\$103,690,295.00</b>

The following table shows the overall cost summary of the recommended changes under this agenda item:

<u>Contract</u>	<u>Contractor</u>	<u>Number</u>	<u>Change Order Cost</u>
No. 1 – General Construction	Alberici Constructors, Inc.	20	\$181,730.00
No. 2 – Mechanical Construction	Wrigley Mechanical, Inc.	N/A	\$0.00
No. 3 – Electrical Construction	JDP Electric, Inc.	N/A	\$0.00
<b>TOTAL</b>			<b>\$181,730.00</b>

With Change Order approval, the new updated contract amounts would be as follows:

<u>Contract</u>	<u>Contractor</u>	<u>Bid Price</u>
No. 1 – General Construction	Alberici Constructors, Inc.	\$82,688,974.05
No. 2 – Mechanical Construction	Wrigley Mechanical, Inc.	\$8,276,134.38
No. 3 – Electrical Construction	JDP Electric, Inc.	\$17,441,352.00
<b>TOTAL</b>		<b>\$108,406,460.43</b>

The project is being paid for through State Water Commission (SWC) grant funding and through a State Revolving Fund (SRF) loan. The SRF loan is administered by the North Dakota Public Finance Authority (PFA) and the North Dakota Department of Health (NDDH). The City of Fargo has now collected the \$30 million in grant funding allotted for the MWTP from the SWC.

**MOTION:**

On a motion by Brenda Derrig, seconded by Scott Liudahl, the Utility Committee voted to approve the proposed change orders with the General Contractor in the total amount of \$181,730.00 for Membrane Water Treatment Plant construction.

<u>COMMITTEE:</u>	<u>Present</u>	<u>Yes</u>	<u>No</u>	<u>Unanimous</u>
				<u>X</u>
				<u>Proxy</u>
Anthony Gehrig, City Commissioner				
Kent Costin, Director of Finance	X			
Brian Ward, Water Plant Supt.	X			
Mark Miller, Wastewater Plant Supt.				
Bruce Grubb, City Administrator	X			
Scott Liudahl, City Forester	X			
Terry Ludlum, Solid Waste Utility Director	X			
James Hausauer, Wastewater Util. Director	X			
Troy Hall, Water Utility Director	X			
Ben Dow, Public Works Operations Director	X			
Brenda Derrig, City Engineer	X			

**ATTEST:**

  
 \_\_\_\_\_  
 Troy B. Hall  
 Water Utility Director

- C: Tim Mahoney, Mayor  
 Commissioner Grindberg  
 Commissioner Piepkorn  
 Commissioner Strand



## MEMORANDUM

October 2, 2018

To: Utility Committee

From: Troy B. Hall, Water Utility Director **TBH**

Re: WA1301 Change Orders – Membrane Water Treatment Plant

Introduction

Construction of the Membrane Water Treatment Plant (MWTP) began in May, 2015. This is Water Utility Project - WA1301. There have been previous change orders for this project approved by the Utility Committee and City Commission. Water utility staff is recommending additional changes to one of the three contracts at this time. A letters of explanation from AE2S and change order form is attached.

After bidding, contracts were approved on April 27, 2015, for Membrane Water Treatment Plant (MWTP) construction to the three prime contractors as follows:

<u>Contract</u>	<u>Contractor</u>	<u>Bid Price</u>
No. 1 – General Construction	Alberici Constructors, Inc.	\$80,044,884.00
No. 2 – Mechanical Construction	Wrigley Mechanical, Inc.	\$6,824,000.00
No. 3 – Electrical Construction	JDP Electric, Inc.	\$16,821,411.00
<b>TOTAL</b>		<b>\$103,690,295.00</b>

With previously approved change orders to the three contracts, the contract amounts prior to the current recommended changes under this agenda item are as follows:

<u>Contract</u>	<u>Contractor</u>	<u>Bid Price</u>
No. 1 – General Construction	Alberici Constructors, Inc.	\$82,507,244.05
No. 2 – Mechanical Construction	Wrigley Mechanical, Inc.	\$8,276,134.38
No. 3 – Electrical Construction	JDP Electric, Inc.	\$17,441,352.00
<b>TOTAL</b>		<b>\$108,224,730.43</b>

The following table shows the overall cost summary of the recommended changes by contractor under this agenda item:

<u>Contract</u>	<u>Contractor</u>	<u>Number</u>	<u>Change Order Cost</u>
No. 1 – General Construction	Alberici Constructors, Inc.	20	\$181,730.00
No. 2 – Mechanical Construction	Wrigley Mechanical, Inc.	N/A	\$0.00
No. 3 – Electrical Construction	JDP Electric, Inc.	N/A	\$0.00
<b>TOTAL</b>			<b>\$181,730.00</b>



With Change Order approval, the new updated contract amounts would be as follows:

<u>Contract</u>	<u>Contractor</u>	<u>Bid Price</u>
No. 1 – General Construction	Alberici Constructors, Inc.	\$82,688,974.05
No. 2 – Mechanical Construction	Wrigley Mechanical, Inc.	\$8,276,134.38
No. 3 – Electrical Construction	JDP Electric, Inc.	\$17,441,352.00
<b>TOTAL</b>		<b>\$108,406,460.43</b>



View of MWTP at the corner of 13<sup>th</sup> Avenue South and 5<sup>th</sup> Street. Retaining block wall and new sidewalk are shown. Photo is from September 29, 2018.

**MWTP Project Status Related Change Orders and Overall Cost**

The MWTP is a large, complicated, and expensive project for the City of Fargo and its water service customers. As such, it is normal for projects of this nature to have adjustments that result in cost change orders. Since the MWTP exceeded \$100 million in bid prices, the following is intended to help provide perspective for this project compared to the cost impacts of change orders commonly seen in the industry.

While it may be difficult to find exact comparators to the MWTP project, the following are typical observations and goals for change order cost increases in the industry at project completion:

- Industry average: **3% to 5% of bid price**
- Typical Project Goal: **<2% of bid price**
- Excellent Project: **<1% of bid price**
- Percentages for change order costs reflect (1) Errors & Omissions and (2) Owner Requested

Change Order (CO) statistics for MWTP project in percentages:

- Prior to Current CO Recommendations: **4.37%**
- Adjusted Value Prior to Current CO Recommendations: **3.05%**
- After Current CO Recommendations: **4.55%**
- Adjusted Value After Current CO Recommendations: **3.23 %**
- Total Adjusted Value Dollar Amount: \$1,369,585 (Different funding source)
  - Generator Switchgear – West Fargo: \$137,816.00 (previously approved CO)
  - 7<sup>th</sup> Reverse Osmosis Train – West Fargo: \$1,068,769.00 (previously approved CO)
  - Black & Veatch contribution to HVAC Changes: \$163,000

Since the MWTP construction project is approaching completion and through a number of the higher risk project components for change orders, Water Utility personnel think the project is at a reasonable position from a change order perspective. 'Value Engineering' and teamwork between contractors, City staff, and consulting engineers has been an important factor in containing costs. The 'Value Engineering' for the foundation system was an important item for cost savings in the project, reducing the contract price by nearly \$300,000 early in construction.

Related to cost change orders, some higher risk project components include:

- Utility Infrastructure Rerouting (removal from excavation/construction areas) - **Complete**
- Mass Excavation (unforeseen underground conditions) - **Complete**
- Foundation (Pile) Installation - **Complete**
- Major Equipment/Treatment Process Submittals – **Complete**
- Concrete for Lower Level & Main Level - **Complete**
- Building Structural Steel, Exterior Brick, and Roof – **Complete**
- Process Piping, Building Electrical, and Mechanical Piping – **Nearly Complete**
- Exterior Landscaping, Paving, and Site Work – **In Progress**

Since the construction of the MWTP is approaching completion, startup process equipment has been in progress for several months. The MWTP is nearly operational at this time. Currently, construction is occurring in the interior of the building, including process piping installation, equipment installation, electrical installation, mechanical/HVAC installation, room finishes, and painting. Most of the construction at this time is related to site work around the building and demobilizing contractors, including paving and landscaping.

A complicating factor for the MWTP construction is the agreement in July, 2015, to provide drinking water to West Fargo. With the addition of West Fargo, Water Utility staff needs to gauge what design adjustments should be recommended for the MWTP, looking at the best long-term interest of the City and customers. These adjustments in most cases will be cost increases. Two significant cost changes attributed to West Fargo water service have previous approval – 7<sup>th</sup> Reverse Osmosis train and electrical switchgear. Costs for the two changes will be funded by State Water Commission regionalization grant funding and infrastructure sales tax (Fund 450). Please be aware that there is annual water sales revenue from West Fargo.

**Detailed Summary of Change Orders**

The cost impact to Contract No. 1 with Alberici Constructors, Inc. is summarized in the following:

<u>No.</u>	<u>Item</u>	<u>Cost</u>	<u>Reason</u>
1	Add Permeate Pump Expansion Joints	\$12,645.00	Expansion/Contraction
2	Shoring Interference at Red River Vault	\$29,548.00	Subsurface Not on Plans
3	Fluoride and Phosphate Containment Are Changes	\$8,972.00	Improved Installation
4	Grit Dock Wall Changes	\$4,567.00	Wall Interference
5	Compressed Air Details and Isolation Valves	\$78,314.00	Not Shown in Plans
6	ChemScan Casework	\$2,751.00	Match Counter/Cabinets
7	Chemical Driveway Demo Items	\$1,796.00	Widened Driveway
8	Sidewalk Addition	\$34,394.00	Replace Not In Plans
9	RO CIP Batch Tank Platforms	\$25,254.00	Chemical Handling
10	CMU Façade Modifications	\$5,567.00	Electric Panel Access
11	Signage Changes	\$853.00	Room Sign Modifications
12	Sodium Hydroxide Fill Piping to Stainless Steel	\$6,024.00	WTP Staff Safety
13	Duct Painting Deduct	(\$28,955.00)	Scope Change
<b>Total – Contract No. 1 Change for Change Order No. 20</b>		<b>\$181,730.00</b>	

**Plan of Financing**

The contract changes under this agenda item will results in an overall cost increase of \$181,730.00 for MWTP construction. The project is being paid for through State Water Commission (SWC) grant funding and through a State Revolving Fund (SRF) loan administered by the North Dakota Public Finance Authority (PFA) and North Dakota Department of Health (NDDH). The \$30 million in grant funding from the SWC has all been received by the City of Fargo for the MWTP project.

**SUGGESTED MOTION:**

Approve the contract change orders with two contractors in the total amount of \$181,730.00 for construction of the MWTP.

Your consideration in this matter is greatly appreciated.



October 1, 2018

Mr. Troy Hall  
Water Utility Director  
City of Fargo  
Water Treatment Plant  
435 14<sup>th</sup> Ave S  
Fargo, ND 58103-4306

**Re: Change Order No. 20**  
**Contract No. 1 Fargo Membrane WTP and Improvements**  
**City of Fargo Project #WA1301**

Dear Mr. Hall:

Enclosed please find four (4) copies of Change Order No. 20 for the above referenced project for your review and approval. This Change Order pertains to the following changes to the project:

1. The flanged coupling adapter where changed to single arch expansion joints on the suction piping for the MF/UF permeate pumps and required a stainless steel flange to be added for installation of the expansion joints.
2. While excavating for the new Red River Valve Vault duct bank interferences were discovered that were not shown on the as-built plans and required changes to the shoring system for the construction of the vault and pushed the work into the winter requiring winter protection over the vault.
3. Concrete pads were added for the four transfer pumps in the existing fluoride and phosphate chemical storage areas and the interior of the new fluoride feed area in the existing WTP will have a protective coating installed.
4. The existing brick ledge on the existing WTP interfered with the exterior wall at the grit dock area and was modified to thicken the wall and modify the reinforcement to not interfere with the existing brick ledge.
5. Compressed air piping connection to the pneumatic valves will require additional detail for sizing and branching to multiple valves, isolation ball valves will be added on the air line to each pneumatic valve, and additional routing detail will be provided at the locations where main air supply headers were not shown.
6. The counter around the ChemScan unit in the Water Quality Lab will be closed up to match the countertop and cabinets around the unit.
7. The transformer pad and light pole base will be removed where the driveway was widened south of the Generator Building.
8. The sidewalk along 13<sup>th</sup> Ave and 5<sup>th</sup> St will be replaced with new sidewalk (this sidewalk was originally shown to be removed on the plans, but not replaced).
9. The platforms for the RO CP Batch Tanks will be increased in size to provide a larger working area and changed to FRP material for corrosion protection within the chemical containment area.

Mr. Troy Hall

Re: **Change Order No. 20**

**Contract No. 1 Fargo Membrane WTP and Improvements**

**City of Fargo Project #WA1301**

**October 1, 2018**

**Page 2 of 2**

10. The CMU façade on the east face of the column in the existing WTP hallway will be removed and replaced with drywall to eliminate the interference with opening the control panel east of the column.
11. Two electrical room signs will be modified to include additional information and five exterior room signs will be added.
12. The exterior section of the two CPVC sodium hydroxide fill lines will be replaced with stainless steel lines, valves, and cam locks to provide a more durable material for the exterior installation.
13. The requirement for painting the duct work throughout the building will be removed, except in the chemical rooms.

The cost impact to Contract No. 1 is summarized in the following:

<u>Item</u>	<u>Cost</u>
1. PCO 143 – Added Permeate Pump Expansion Joints	\$12,645.00
2. PCO 221 – Shoring Interference at Red River Vault	\$29,548.00
3. PCO 233 – Fluoride and phosphate containment area changes	\$8,972.00
4. PCO 268 – Grit Dock Wall Changes	\$4,567.00
5. PCO 271 – Compressed Air Details and Isolation Valves	\$78,314.00
6. PCO 348 – ChemScan Casework	\$2,751.00
7. PCO 359 – Chemical Driveway Demo Items	\$1,796.00
8. PCO 361 – Sidewalk Addition	\$34,394.00
9. PCO 362 – RO Batch Tank Platforms	\$25,254.00
10. PCO 366 – CMU Façade Modification	\$5,567.00
11. PCO 368 – Signage Changes	\$853.00
12. PCO 370 – NaOH Fill Piping to SS	\$6,024.00
13. PCO 372 – Duct Painting Deduct	(\$28,955.00)
 <b>Total for Change Order No. 20 =</b>	 <b>\$181,730.00</b>

Upon the City of Fargo’s acceptance of Change Order No. 20, please sign and date the four original copies. Retain one copy for your records and return the remaining three copies to AE2S. AE2S will forward one copy each to the North Dakota Department of Health and ACI and will retain the remaining copy for our records. Please contact me if you have any questions or need additional information.

Sincerely,

AE2S

Ben Julson, PE  
Project Engineer

# Change Order

No. 20

Date of Issuance: 10/08/2018 Effective Date: 10/08/2018

Project: Fargo Membrane WTP and Improvements	Owner: City of Fargo	Owner's Contract No.: WA1301
Contract: Contract No. 1 – General Construction		Date of Contract: 04/27/2015
Contractor: Alberici Constructors Inc.		Engineer's Project No.: P00803-2009-25

**The Contract Documents are modified as follows upon execution of this Change Order:**

Description: See attached Description of Work.

Attachments: Description of Work  
Supporting documents for Change Order Items

CHANGE IN CONTRACT PRICE:	CHANGE IN CONTRACT TIMES:
Original Contract Price: \$ <u>80,044,884.00</u>	Original Contract Times: <input type="checkbox"/> Working days <input type="checkbox"/> Calendar days — Substantial completion (days or date): _____ — Ready for final payment (days or date): _____
[Increase] [Decrease] from previously approved Change Orders No. <u>1</u> to No. <u>19</u> : \$ <u>2,462,360.05</u>	[Increase] [Decrease] from previously approved Change Orders No. _____ to No. _____ : — Substantial completion (days): _____ — Ready for final payment (days): _____
Contract Price prior to this Change Order: \$ <u>82,507,244.05</u>	Contract Times prior to this Change Order: — Substantial completion (days or date): _____ — Ready for final payment (days or date): _____
[Increase] [Decrease] of this Change Order: \$ <u>181,730.00</u>	[Increase] [Decrease] of this Change Order: — Substantial completion (days or date): _____ — Ready for final payment (days or date): _____
Contract Price incorporating this Change Order: \$ <u>82,688,974.05</u>	Contract Times with all approved Change Orders: — Substantial completion (days or date): _____ — Ready for final payment (days or date): _____

RECOMMENDED:	ACCEPTED:	ACCEPTED:
By: _____ Engineer (Authorized Signature)	By: _____ Owner (Authorized Signature)	By: _____ Contractor (Authorized Signature)
Date: _____	Date: _____	Date: _____
Approved by Funding Agency (if applicable): _____		Date: _____

September 21, 2018

(41)

Board of City Commissioners  
City of Fargo  
200 North Third Street  
Fargo, ND 58102

**Re: Memorandum of Offer to Landowner  
Temporary Easement (Construction)  
Improvement District #BN-19-A1**

Dear Commissioners:

Enclosed and delivered to the City Commission office is an original Memorandum of Offer to Landowner document for the acquisition of a temporary easement in association with Improvement District #BN-19-A1. Final purchase price has been reached and at this time we are requesting authorization from the Commission to proceed with the purchase. All land acquisition procedures have been followed and the City Engineer's office recommends purchase.

RECOMMENDED MOTION: I/we hereby move to approve and authorize purchase of a temporary easement from **West Fargo Investments, LLC** in association with Improvement District #BN-19-A1 and that the Mayor is instructed to execute the Memorandum of Offer to Landowner on behalf of the City of Fargo.

Please return a copy of the signed originals.

Respectfully submitted,

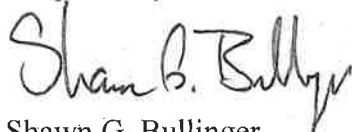

Shawn G. Bullinger  
Land Acquisition Specialist

C: Jeremy Gorden  
Nancy J. Morris



PARCEL 28A  
 PART OF LOT 4, BLOCK 1  
 OSGOOD TOWNSITE FIFTEENTH ADDITION  
 CITY OF FARGO, CASS COUNTY  
 STATE OF NORTH DAKOTA

OWNER: WEST FARGO INVESTMENTS LLC

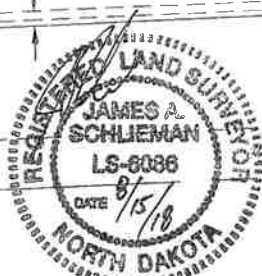
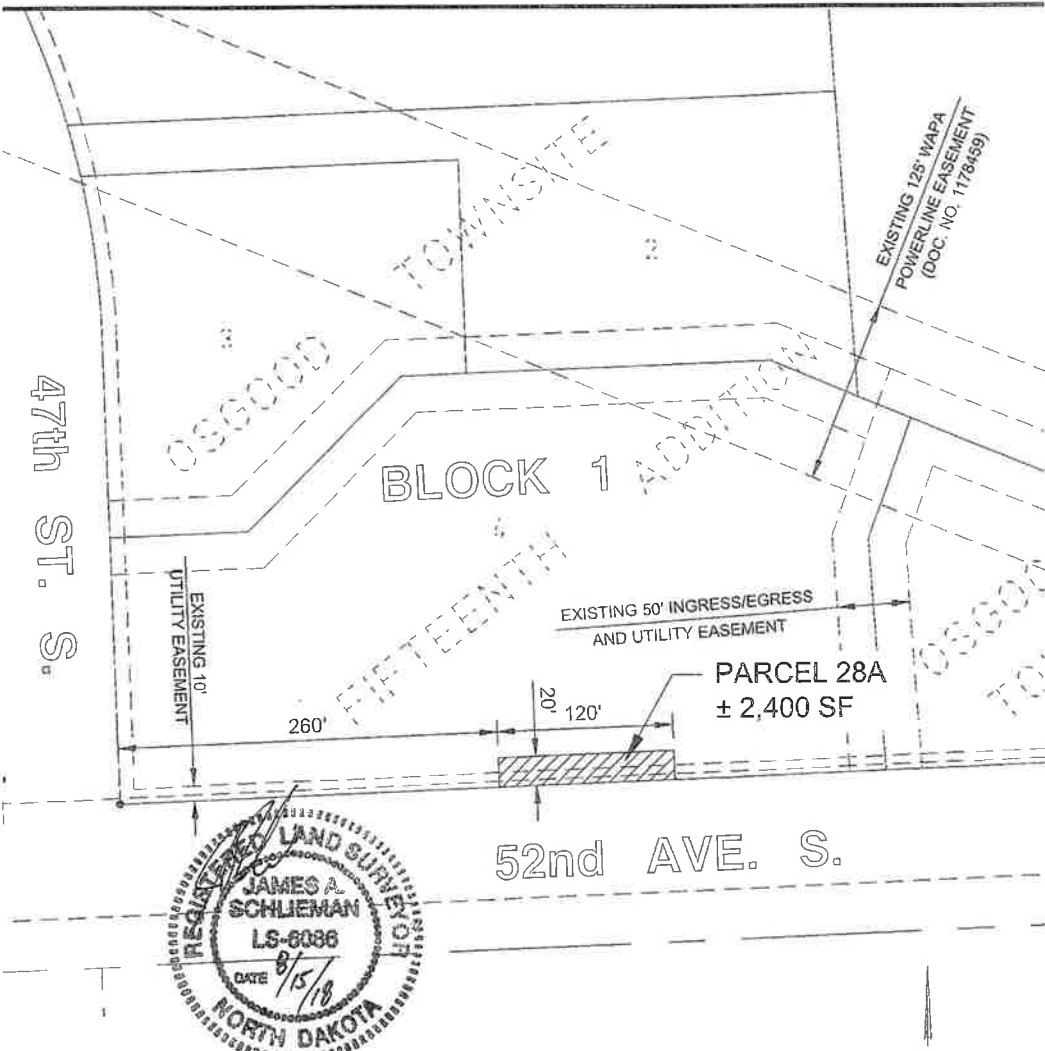

**Description- Parcel 28A: (Temporary Construction Easement)**

The South 20.00 feet of the East 120.00 feet of the West 380.00 feet of Lot 4, Block 1, Osgood Township Fifteenth Addition to the City of Fargo, Cass County, North Dakota.

Said tract contains 2,400 square feet, more or less.

Scale: 1"= 100'

IRON MONUMENT FOUND	•
MEASURED BEARING	S59°27'46"E
MEASURED DISTANCE	105.00'
PLAT BEARING	(N57°00'00"W)
PLAT DISTANCE	(105.00')
TEMPORARY EASEMENT	///////

NOTE: ALL BEARINGS GIVEN ARE BASED ON THE CITY OF FARGO GIS COORDINATE SYSTEM.

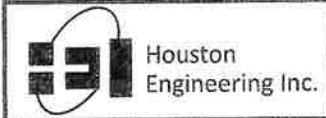

# EASEMENT EXHIBIT

PROJECT NO. 6059-0145	PART OF LOT 4, BLOCK 1, OSGOOD TOWNSITE FIFTEENTH ADDITION, CITY OF FARGO, CASS CO., ND	SHEET 1 OF 1
--------------------------	--	-----------------

H:\Fargo\UBN\G000\6059\18\_6059\_145 - 52nd Ave. Design\CAD\Exhibit\Easement Exhibit3.dwg-Exhibit 28-9/6/2018 4:09 PM-(kstroud)



200 3rd Street North  
Fargo, North Dakota 58102  
Phone: (701) 241-1545  
Fax: (701) 241-8101  
E-Mail: feng@cityoffargo.com

September 21, 2018

42

Board of City Commissioners  
City of Fargo  
200 North Third Street  
Fargo, ND 58102

**Re: Memorandum of Offer to Landowner  
Temporary Easement (Construction)  
Improvement District #BN-19-A1**

Dear Commissioners:

Enclosed and delivered to the City Commission office is an original Memorandum of Offer to Landowner document for the acquisition of a temporary easement in association with Improvement District #BN-19-A1. Final purchase price has been reached and at this time we are requesting authorization from the Commission to proceed with the purchase. All land acquisition procedures have been followed and the City Engineer's office recommends purchase.

RECOMMENDED MOTION: I/we hereby move to approve and authorize purchase of a temporary easement from **Julie L. Vetter** and **Aaron D. Olson** in association with Improvement District #BN-19-A1 and that the Mayor is instructed to execute the Memorandum of Offer to Landowner on behalf of the City of Fargo.

Please return a copy of the signed originals.

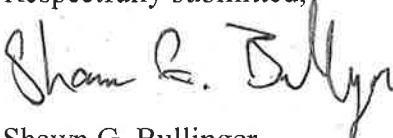
Respectfully submitted,  
  
Shawn G. Bullinger  
Land Acquisition Specialist

C: Jeremy Gorden  
Nancy J. Morris

**MEMORANDUM OF OFFER TO LANDOWNER**

City of Fargo, Engineering Department

Project BN-19-A1	County Cass	Parcel(s) 5A
Landowner Julie L. Vetter & Aaron D. Olson		
Mailing Address 322 51 Ave E West Fargo, ND 58078		

The following-described real property and/or related temporary easement areas are being acquired for project purposes:

See attached exhibit(s).

I, as right of way agent for the City of Fargo, Engineering Department, am hereby authorized to offer the following amount of \$ 928.00 as full compensation for the fee and/or temporary taking of the foresaid parcels and all damages incidental thereto. The offer set forth has been established through one of the following, Basic Data Book, Certified Appraisal, City of Fargo Minimum Payment Policy. A breakdown of this offer is as follows:

Land	\$	<u>                    </u>
Easement and Access Control	\$	<u>          928.00</u>
Improvements on Right of Way*	\$	<u>                    </u>
Damages to Remainder	\$	<u>                    </u>
<b>Total Offer</b>	<b>\$</b>	<b><u>                    928.00</u></b>

\*Description of Damages to Remainder are as follows:

---

 9-18-18  
 Owner Signature  
 Signature hereby constitutes acceptance of offer as presented above.

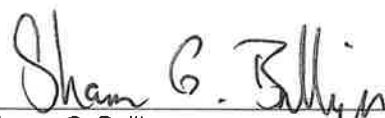
  
 Shawn G. Bullinger  
 Land Acquisition Specialist, City of Fargo

*Fargo City Commision has considered the offer and approves the same:*



Timothy J. Mahoney  
 MAYOR  
 SIGNATURE  
 DATE

**MEMORANDUM OF OFFER TO LANDOWNER**

City of Fargo, Engineering Department

Project BN-19-A1	County Cass	Parcel(s) 5A
Landowner Julie L. Vetter & Aaron D. Olson		
Mailing Address 322 51 Ave E West Fargo, ND 58078		

The following-described real property and/or related temporary easement areas are being acquired for project purposes:

See attached exhibit(s).

I, as right of way agent for the City of Fargo, Engineering Department, am hereby authorized to offer the following amount of \$ 928.00 as full compensation for the fee and/or temporary taking of the foresaid parcels and all damages incidental thereto. The offer set forth has been established through one of the following, Basic Data Book, Certified Appraisal, City of Fargo Minimum Payment Policy. A breakdown of this offer is as follows:

Land	\$	_____
Easement and Access Control	\$	<u>928.00</u>
Improvements on Right of Way*	\$	_____
Damages to Remainder	\$	_____
<b>Total Offer</b>	<b>\$</b>	<b><u>928.00</u></b>

\*Description of Damages to Remainder are as follows:

Julie Vetter 9-18-18  
 Owner Signature  
 Signature hereby constitutes acceptance of offer as presented above.

Shawn G. Bullinger  
 Shawn G. Bullinger  
 Land Acquisition Specialist, City of Fargo

*Fargo City Commision has considered the offer and approves the same:*



Timothy J. Mahoney  
 MAYOR  
 SIGNATURE  
 DATE

PARCEL 5A  
 PART OF LOT 5, BLOCK 3  
 MCMAHON ESTATES THIRD SUBDIVISION  
 CITY OF FARGO, CASS COUNTY  
 STATE OF NORTH DAKOTA

OWNER: JULIE L VETTER ETAL

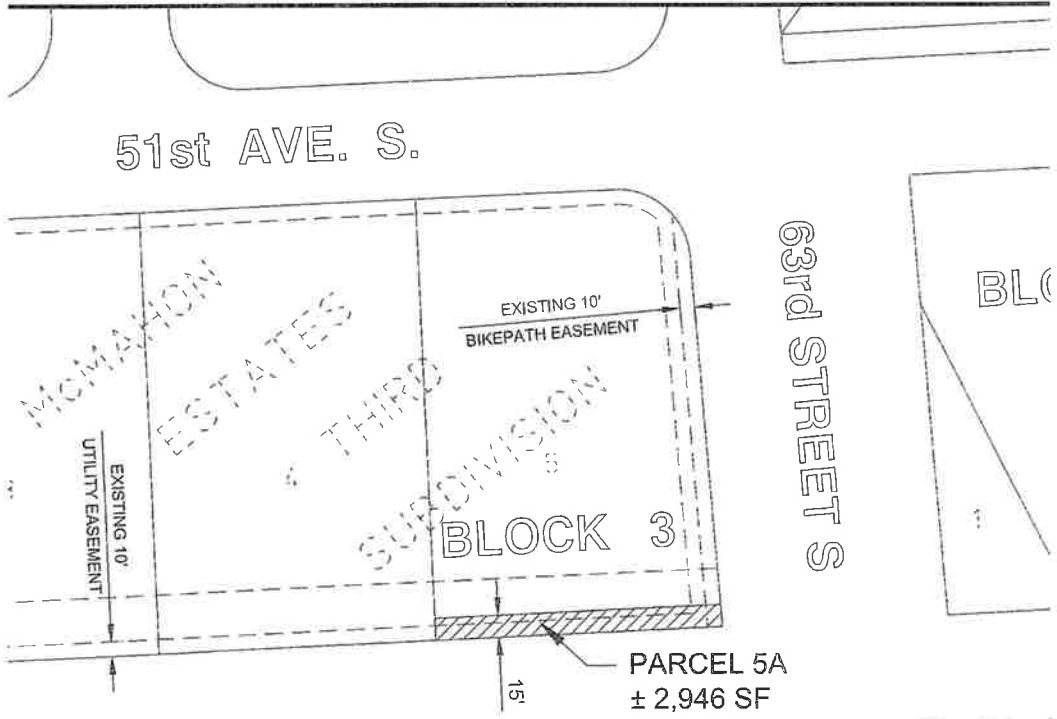

52nd AVE. S.



**Description- Parcel 5A: (Temporary Construction Easement)**

The South 15.00 feet of Lot 5, Block 3, McMahon Estates Third Subdivision, in the City of West Fargo, Cass County, North Dakota,  
 Said tract contains 2,946 square feet, more or less.

Scale: 1"= 100'

IRON MONUMENT FOUND	•
MEASURED BEARING	S59°27'46"E
MEASURED DISTANCE	105.00'
PLAT BEARING	(N57°00'00"W)
PLAT DISTANCE	(105.00')
TEMPORARY EASEMENT	//////

NOTE: ALL BEARINGS GIVEN ARE  
 BASED ON THE CITY OF  
 FARGO GIS COORDINATE  
 SYSTEM.

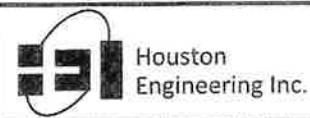

**EASEMENT EXHIBIT**

PROJECT NO.  
 6059-0145

PART OF LOT 5, BLOCK 3, MCMAHON ESTATES THIRD  
 SUBDIVISION, CITY OF FARGO, CASS CO., ND

SHEET  
 1 OF 1

H:\Fargo\UB\60000605918\_6059\_145\_52nd Ave. Design\CAD\Exhibits\Easement Exhibits.dwg-Exhibit 5-8/15/2018 1:08 PM-(kstroud)

REPORT OF ACTION

PUBLIC WORKS PROJECTS EVALUATION COMMITTEE

43

Improvement District No. BN-17-A3

Type: Amendment #1

Location: 19<sup>th</sup> Ave N, 57<sup>th</sup> St to 45<sup>th</sup> St

Date of Hearing: 9/17/2018

<u>Routing</u>	<u>Date</u>
City Commission	<u>10/8/2018</u>
PWPEC File	<u>X</u>
Project File	<u>Jason Leonard</u>

The Committee reviewed the accompanying correspondence from Project Manager, Jason Leonard, related to Amendment #1 in the amount of \$145,301.00 for additional construction administration by KLJ

The Substantial Completion date was August 13, 2018. The project is still under construction with an anticipated Substantial Completed date of October 31, 2018. Liquidated Damages are being assessed against the Contractor.

Staff is recommending approval.

On a motion by Kent Costin, seconded by Bruce Grubb, the Committee voted to recommend approval of Amendment #1.

RECOMMENDED MOTION

Concur with PWPEC recommendation and approve Amendment #1 with KLJ in the amount of \$145,301.00.

PROJECT FINANCING INFORMATION:

Recommended source of funding for project: Waste Water Utility & Special Assessments

	<u>Yes</u>	<u>No</u>
Developer meets City policy for payment of delinquent specials	<u>N/A</u>	<u>        </u>
Agreement for payment of specials required of developer	<u>N/A</u>	<u>        </u>
Letter of Credit required (per policy approved 5-28-13)	<u>N/A</u>	<u>        </u>

COMMITTEE

	<u>Present</u>	<u>Yes</u>	<u>No</u>	<u>Unanimous</u>
Tim Mahoney, Mayor	<input checked="" type="checkbox"/>	<input checked="" type="checkbox"/>	<input type="checkbox"/>	<input checked="" type="checkbox"/>
Nicole Crutchfield, Director of Planning	<input checked="" type="checkbox"/>	<input checked="" type="checkbox"/>	<input type="checkbox"/>	Donald Kress
Steve Dirksen, Fire Chief	<input checked="" type="checkbox"/>	<input checked="" type="checkbox"/>	<input type="checkbox"/>	
Bruce Grubb, City Administrator	<input checked="" type="checkbox"/>	<input checked="" type="checkbox"/>	<input type="checkbox"/>	
Ben Dow, Director of Operations	<input checked="" type="checkbox"/>	<input checked="" type="checkbox"/>	<input type="checkbox"/>	
Steve Sprague, City Auditor	<input checked="" type="checkbox"/>	<input checked="" type="checkbox"/>	<input type="checkbox"/>	
Brenda Derrig, City Engineer	<input checked="" type="checkbox"/>	<input checked="" type="checkbox"/>	<input type="checkbox"/>	
Kent Costin, Finance Director	<input checked="" type="checkbox"/>	<input checked="" type="checkbox"/>	<input type="checkbox"/>	

ATTEST:

C: Kristi Olson

  
 Brenda E. Derrig, PE  
 City Engineer

# Memorandum

**To:** PWPEC  
**From:** Jason Leonard, Civil Engineer II  
**C:** Travis Wieber, KLJ  
**Date:** 09/10/2018  
**Re:** Master Services Agreement Task Order No. BN-17-A3 for Improvement District BN-17-A1 – 19<sup>th</sup> Ave N from 57<sup>th</sup> St N to 45<sup>th</sup> St N

**Background:**

The substantial completion date for Improvement District BN-17-A1 is August 13, 2018 and this project is still under construction with an anticipated Substantial Completion date of October 31, 2018. The Contractor is being charged Substantial Completion Liquidated Damages.

Due the change in construction contract duration for an additional 11-weeks of construction, KLJ is requesting a contract amendment to cover the additional construction administration efforts for this period.

Attached is a letter and cost breakdown requesting a contract amendment in the amount of \$145,301.00 to complete the Construction Administration of 19<sup>th</sup> Avenue North. KLJ was awarded the contract in the following amount:

	Construction Administration
Original Contract	\$ 499,891.00
Amendment No. 1	<u>\$ 145,301.00</u>
Final	\$ 649,192.00

**Recommended Motion:**

Approve Amendment # 1 in the amount of \$145,301.00 to KLJ, Inc. for Improvement District #BN-18-A3 - 19<sup>th</sup> Avenue North from 57<sup>th</sup> St N to 45<sup>th</sup> St N.



**CITY OF FARGO  
ENGINEERING DEPARTMENT  
CHANGE ORDER REPORT**

**Improvement District No** BN-17-A3      **Change Order No** 1  
**Project Name** Consultant Services  
**Date Entered** 9/12/2018      **For** Kadrmas Lee & Jackson Inc

This change is made under the terms of or is supplemental to your present contract, if and when approved, you are ordered to perform the work in accordance with the additions, changes, or alterations hereinafter described.

**EXPLANATION OF CHANGE:** Change Order # 1 - Master Services Agreement Task Order No. BN-17-A3 for I.D. BN-17-A1

The change in construction duration on 19th Avenue North is anticipated to take an additional 11 weeks. KLJ is requesting a contract amendment in the amount of \$145,301.00 to cover the additional construction administration efforts for this period.

Section	Line No	Item Description	Unit	Orig Cont Qty	Prev C/O Qty	Prev Cont Qty	Curr C/O Qty	Tot Cont Qty	Unit Price (\$)	C/O Ext Price (\$)
Consultant Services	1	Construction Administration	EA	499,891.00	0.00	499,891.00	145,301.00	645,192.00	1.00	145,301.00
<b>Consultant Services Sub Total (\$)</b>										
145,301.00										

**Summary**

**Source Of Funding** Special Assessments

**Net Amount Change Order # 1 (\$)** 145,301.00

**Previous Change Orders (\$)** 0.00

**Original Contract Amount (\$)** 499,891.00

**Total Contract Amount (\$)** 645,192.00

I hereby accept this order both as to work to be performed and prices on which payment shall be based.

**CONTRACT TIME**

Current Substantial Completion Date	Current Final Completion Date	Additional Days Substantial Completion	Additional Days Final Completion	New Substantial Completion Date	New Final Completion Date
06/01/2018		0.00	0.00	06/01/2018	

**Description**

**APPROVED**

**APPROVED DATE**



CITY OF FARGO  
ENGINEERING DEPARTMENT  
CHANGE ORDER REPORT

For Contractor

*[Handwritten Signature]*  
Title *Vice President*

Department Head

*[Handwritten Signature]* 9/25/18

Mayor

Attest





3203 32nd Avenue South, Suite 201  
Fargo, ND 58103-6242  
701 232 5353  
KLJENG.COM

August 31, 2018

Jason Leonard  
City of Fargo  
200 3rd Street North  
Fargo, ND 58102

**Re: BN-17-A1 – Construction Administration Amendment Request**

Dear Jason:

KLJ would like to request an amendment to the construction engineering task order for the reference project.

The current substantial completion date for the project was August 13, 2018. The project is still under construction and the anticipated substantial completion date is October 31, 2018. This equates to an additional 11-weeks of construction. KLJ is requesting a contract amendment to cover the additional construction administration efforts for this period. Please see the attached cost breakdown for additional details.

Our subconsultant, AE2S, has also requested an amendment for additional work performed on the project. Their amendment request is attached for your reference.

The above items will increase the total contract from **\$499,891** to **\$649,192**.

We appreciate your consideration for this contract amendment. Please feel free to contact me with any questions at 701.271.4863 or [travis.wieber@klijeng.com](mailto:travis.wieber@klijeng.com).

Sincerely,

**KLJ**

A handwritten signature in black ink, appearing to read 'Travis Wieber', written in a cursive style.

Travis Wieber  
Project Manager

Enclosure(s): Cost Breakdown, AE2S Amendment Request

Project #: 14417100

cc: Richard Wagner, AE2S



<b>Construction Inspection</b>				
<b>Staff Type</b>	<b>Standard Hourly Rate</b>	<b>Number of Staff</b>	<b>Hours/Week</b>	<b>Cost for 11 Weeks</b>
Engineer I	\$ 94.00	1.5	51	\$ 79,101.00
<b>Construction Administration</b>				
<b>Staff Type</b>	<b>Standard Hourly Rate</b>	<b>Number of Staff</b>	<b>Hours/Week</b>	<b>Cost for 11 Weeks</b>
Engineer III	\$ 136.00	1	5	\$ 7,480.00
<b>Construction Staking</b>				
<b>Staff Type</b>	<b>Standard Hourly Rate</b>	<b>Number of Staff</b>	<b>Hours/Week</b>	<b>Cost for 11 Weeks</b>
Surveyor I	\$ 78.00	1	15	\$ 12,870.00
Surveyor III	\$ 112.00	1	15	\$ 18,480.00
Surveyor IV	\$ 170.00	1	1	\$ 1,870.00
<b>Sub Total</b>				<b>\$ 33,220.00</b>
<b>Subconsultants</b>				
<b>Subconsultant</b>	<b>Role</b>		<b>Cost</b>	
AE2S	Storm Sewer Lift Station Inspection		\$	25,500.00
<b>Total Cost</b>			\$	<b>145,301.00</b>



August 30, 2018

Scott Middaugh, PE  
Kadmas, Lee & Jackson, Inc.  
PO Box 9767  
Fargo, ND 58106

**Re: 19<sup>th</sup> Ave N from 57<sup>th</sup> Street to 45<sup>th</sup> Street North  
City of Fargo Improvement District BN-17-A1  
Construction Phase Services**

Dear Mr. Middaugh:

AE2S is currently providing Construction Phase Services for the stormwater lift station work on the 19<sup>th</sup> Ave N from 57<sup>th</sup> Street to 45<sup>th</sup> Street North Project (19<sup>th</sup> Ave Project). AE2S's fee submitted to KLJ for the Construction Phase Services on this project was based on the work shown and project completion dates established within the project plans. The 19<sup>th</sup> Ave Project has deviated from these parameters, which has resulted in the need for additional professional services fees. The additional scope items and associated fees are listed below.

1. Grade change on the storm sewer pipe installed beneath 45th Street.
  - a. AE2S re-analyzed the pond and lift station hydraulics due to the storm sewer pipe being installed several feet higher than originally designed.
  - b. AE2S revised structural details and reviewed re-submittals for the precast concrete structures and gates impacted by installation of the storm sewer pipe at an elevation several feet higher than originally shown on project plans.
  - c. Additional fee requested by AE2S: \$8,000.
2. Contractor requested to change the gate well and wet well structures to precast in lieu of cast-in-place as originally designed.
  - a. AE2S reviewed submittals and design calculations for the precast structures.
  - b. Additional fee requested by AE2S: \$2,500.
3. Extended construction duration.
  - a. The substantial completion of the stormwater lift station was April 1, 2018. As of August 30, 2018, the work was not substantially complete. AE2S is assuming this work will be substantially complete by September 28, 2018.
  - b. Additional fee requested by AE2S: \$15,000.

The project changes listed above result in a total estimated increase of \$25,500 for additional services. Should you have any questions or need additional information, please contact me at 218-299-5610.

Sincerely,  
AE2S

Richard Wagner, PE  
Assistant Operations Manager

REPORT OF ACTION

PUBLIC WORKS PROJECTS EVALUATION COMMITTEE

44

Improvement District No. BR-16-E1 Type: Negative Final Balancing Change Order #1

Location: 2<sup>nd</sup> St N from Main Ave to 1<sup>st</sup> Ave N Date of Hearing: 10/1/2018

<u>Routing</u>	<u>Date</u>
City Commission	10/8/2018
PWPEC File	X
Project File	Rick Larson

The Committee reviewed the accompanying correspondence from Project Manager, Rick Larson, for Negative Final Balancing Change Order #1 in the amount of \$-10,932.93, bringing the total contract amount to \$2,177,242.86.

Staff is recommending approval of Negative Final Balancing Change Order #1.

On a motion by Bruce Grubb, seconded by Brenda Derrig, the Committee voted to recommend approval of Negative Final Balancing Change Order #1.

RECOMMENDED MOTION

Approve Negative Final Balancing Change Order #1 in the amount of \$-10,932.93 to Robert Gibb & Sons.

PROJECT FINANCING INFORMATION:

Recommended source of funding for project: State, Federal, Sales Tax, Water Utility, Waste Water Utility & Special Assessments

Developer meets City policy for payment of delinquent specials Agreement for payment of specials required of developer Letter of Credit required (per policy approved 5-28-13)

<u>Yes</u>	<u>No</u>
N/A	N/A
N/A	N/A
N/A	N/A

COMMITTEE

- Tim Mahoney, Mayor
- Nicole Crutchfield, Director of Planning
- Steve Dirksen, Fire Chief
- Bruce Grubb, City Administrator
- Ben Dow, Director of Operations
- Steve Sprague, City Auditor
- Brenda Derrig, City Engineer
- Kent Costin, Finance Director

<u>Present</u>	<u>Yes</u>	<u>No</u>	<u>Unanimous</u>
<input checked="" type="checkbox"/>	<input checked="" type="checkbox"/>	<input type="checkbox"/>	<input checked="" type="checkbox"/>
<input checked="" type="checkbox"/>	<input checked="" type="checkbox"/>	<input type="checkbox"/>	
<input checked="" type="checkbox"/>	<input checked="" type="checkbox"/>	<input type="checkbox"/>	
<input checked="" type="checkbox"/>	<input checked="" type="checkbox"/>	<input type="checkbox"/>	
<input checked="" type="checkbox"/>	<input checked="" type="checkbox"/>	<input type="checkbox"/>	
<input checked="" type="checkbox"/>	<input checked="" type="checkbox"/>	<input type="checkbox"/>	
<input checked="" type="checkbox"/>	<input checked="" type="checkbox"/>	<input type="checkbox"/>	

ATTEST:

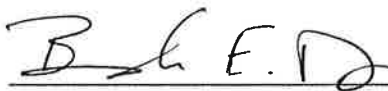
  
 Brenda E. Derrig, P.E.  
 City Engineer

C: Kristi Olson



ENGINEERING DEPARTMENT  
225 4<sup>th</sup> Street North  
Fargo, North Dakota 58102  
Phone: (701) 241-1545  
Fax: (701) 241-8101  
E-Mail: Feng@FargoND.gov

# Memorandum

**To:** Members of PWPEC  
**From:** Rick Larson, Project Manager  
**Date:** September 24, 2018  
**Re:** Final Balancing Change Order #1 – Improvement District #BR-16-E1  
Water Main Replacement, Force Main Construction, Street Reconstruction & Incidentals

---

Attached is a final balancing change order in the amount of -\$10,932.93 for Improvement District No. BR-16-E1. Please refer to the attached Final Balancing Change Order (FBCO), which reconciles the measured quantities with those estimated for the contract.

Original Contract: \$ 2,188,175.79  
FBCO Amount: \$ -10,932.93 (0.50% decrease)  
Total Contract: \$ 2,177,242.86

**Recommended Motion:**  
Approve Final Balancing Change Order #1 in the amount of -\$10,932.93 to Robert Gibb & Sons.

RJL/klo  
Attachment  
C: Tom Knakmuhs



CITY OF FARGO  
ENGINEERING DEPARTMENT  
CHANGE ORDER REPORT

Improvement District No BR-16-E1 Change Order No 1  
 Project Name Water Main Replacement, Force Main Construction, Street Reconstruction & Incidentals  
 Date Entered 9/20/2018 For Robert Gibb & Sons Inc

This change is made under the terms of or is supplemental to your present contract, if and when approved, you are ordered to perform the work in accordance with the additions, changes, or alterations hereinafter described.

**EXPLANATION OF CHANGE:** Final Balancing

This change order reconciles the estimated quantities used in the contract with the final quantities as measured in the field.

Section	Line No	Item Description	Unit	Orig Cont Qty	Prev C/O Qty	Prev Cont Qty	Curr C/O Qty	Tot Cont Qty	Unit Price (\$)	C/O Ext Price (\$)	
HMGP	1	Remove Pavement All Thicknesses All Types	SY	2,620.00	0.00	2,620.00	-99.91	2,520.09	11.00	-1,099.01	
	2	Remove Curb & Gutter	LF	1,180.00	0.00	1,180.00	-19.00	1,161.00	7.00	-133.00	
	3	Subgrade Preparation	SY	2,725.00	0.00	2,725.00	2.06	2,727.06	4.00	8.24	
	4	F&I Woven Geotextile	SY	2,725.00	0.00	2,725.00	2.06	2,727.06	2.50	5.15	
	5	F&I Class 5 Agg - 12" Thick	SY	2,725.00	0.00	2,725.00	2.06	2,727.06	16.00	32.96	
	6	F&I Edge Drain 4" Dia PVC	LF	915.00	0.00	915.00	-214.60	700.40	11.00	-2,360.60	
	7	F&I Curb & Gutter Standard (Type II)	LF	1,180.00	0.00	1,180.00	-42.70	1,137.30	48.00	-2,049.60	
Sanitary Sewer	8	F&I Pavement 9" Thick Doweled Conc	SY	2,125.00	0.00	2,125.00	-113.14	2,011.86	135.00	-15,273.90	
	9	F&I Pipe w/GB DR 25 - 24" Dia PVC	LF	800.00	0.00	800.00	7.80	807.80	126.00	982.80	
	12	F&I Insulation 4" Thick	SY	100.00	0.00	100.00	-60.89	39.11	14.00	-852.46	
Sanitary Sewer	15	F&I 1-1/4" Trench Found Rock 14" thru 24" Dia	LF	100.00	0.00	100.00	229.00	329.00	5.00	1,145.00	
	20	F&I Pipe w/GB SDR 35 - 15" Dia PVC	LF	340.00	0.00	340.00	-9.20	330.80	84.00	-19,594.42	
									<b>HMGP Sub Total (\$)</b>	<b>84.00</b>	<b>-772.80</b>
Water Main Replacement	23	Remove Pipe All Sizes All Types	LF	380.00	0.00	380.00	-30.20	349.80	11.00	-332.20	
	24	F&I Pipe w/GB C900 DR 16 - 6" Dia PVC	LF	20.00	0.00	20.00	-3.70	16.30	59.00	-218.30	
										<b>Sanitary Sewer Sub Total (\$)</b>	<b>11.00</b>



CITY OF FARGO  
ENGINEERING DEPARTMENT  
CHANGE ORDER REPORT

25	F&I Pipe w/GB C900 DR 18 - 8" Dia PVC	LF	20.00	0.00	20.00	-9.00	11.00	66.00	-594.00
26	F&I Pipe w/GB C900 DR 18 - 10" Dia PVC	LF	825.00	0.00	825.00	-21.40	803.60	72.00	-1,540.80
27	Bore Pipe C900 DR 18 - 10" Dia PVC	LF	75.00	0.00	75.00	-12.50	62.50	142.00	-1,775.00
32	F&I Gate Valve 8" Dia	EA	3.00	0.00	3.00	-1.00	2.00	2,400.00	-2,400.00
33	F&I Gate Valve 10" Dia	EA	2.00	0.00	2.00	2.00	4.00	3,600.00	7,200.00
34	F&I 1-1/4" Trench Found Rock 4" thru 12" Dia	LF	100.00	0.00	100.00	174.00	274.00	5.00	870.00
<b>Water Main Replacement Sub Total (\$)</b>									
35	Remove Pavement All Thicknesses All Types	SY	3,580.00	0.00	3,580.00	-53.74	3,526.26	9.00	1,209.70
36	Remove Curb & Gutter	LF	1,780.00	0.00	1,780.00	44.20	1,824.20	7.00	309.40
37	Remove Sidewalk All Thicknesses All Types	SY	1,215.00	0.00	1,215.00	182.78	1,397.78	7.00	1,279.46
38	Remove Driveway All Thicknesses All Types	SY	65.00	0.00	65.00	11.97	76.97	7.00	83.79
39	Subgrade Preparation	SY	3,800.00	0.00	3,800.00	17.72	3,817.72	4.00	70.88
40	F&I Woven Geotextile	SY	3,800.00	0.00	3,800.00	17.72	3,817.72	2.50	44.30
41	F&I Class 5 Agg - 8" Thick	SY	1,075.00	0.00	1,075.00	15.66	1,090.66	13.00	203.58
42	F&I Class 5 Agg - 12" Thick	SY	2,725.00	0.00	2,725.00	2.08	2,727.08	16.00	33.28
43	F&I Edge Drain 4" Dia PVC	LF	1,230.00	0.00	1,230.00	-529.60	700.40	11.00	-5,825.60
44	F&I Curb & Gutter Standard (Type II)	LF	1,600.00	0.00	1,600.00	26.00	1,626.00	46.00	1,196.00
45	F&I Median Nose - Conc	SY	15.00	0.00	15.00	10.53	25.53	134.00	1,411.02
46	F&I Pavement 9" Thick Doweled Conc	SY	2,125.00	0.00	2,125.00	-48.04	2,076.96	135.00	-6,485.40
47	F&I Aggregate for Asph Pavement FAA 43	TON	350.00	0.00	350.00	5.31	355.31	66.00	350.46
48	F&I Asphalt Cement PG 58-34	GAL	4,850.00	0.00	4,850.00	-171.16	4,678.84	2.50	-427.90
49	F&I Sidewalk 4" Thick Reinf Conc	SY	1,550.00	0.00	1,550.00	-51.08	1,498.92	61.00	-3,115.88
50	F&I Sidewalk 6" Thick Reinf Conc	SY	80.00	0.00	80.00	-31.74	48.26	74.00	-2,348.76
51	F&I Impressioned 6" Thick Reinf Conc	SY	700.00	0.00	700.00	68.24	768.24	220.00	15,012.80
52	F&I Det Warn Panels Cast Iron	SF	120.00	0.00	120.00	-14.00	106.00	53.00	-742.00



**CITY OF FARGO  
ENGINEERING DEPARTMENT  
CHANGE ORDER REPORT**

<b>Paving</b>	53	F&I Driveway 6" Thick Reinf Conc	SY	110.00	0.00	110.00	103.68	213.68	96.00	9,953.28
	54	Casting to Grade - no Conc	EA	33.00	0.00	33.00	-4.00	29.00	250.00	-1,000.00
	56	F&I Flat MH Cover 8" Thick Reinf Conc	EA	1.00	0.00	1.00	-1.00	0.00	421.44	-421.44
	58	Rem & Repl Casting - Floating Manhole	EA	1.00	0.00	1.00	-1.00	0.00	1,350.00	-1,350.00
	60	Temp Construction Entrance	EA	2.00	0.00	2.00	-1.00	1.00	3,200.00	-3,200.00
	61	Seeding Type B	SY	350.00	0.00	350.00	604.32	954.32	0.60	362.59
	62	Mulching Type 1 - Hydro	SY	350.00	0.00	350.00	604.32	954.32	0.60	362.59
	63	Weed Control Type B	SY	350.00	0.00	350.00	-350.00	0.00	0.25	-87.50
	64	Inlet Protection - Existing Inlet	EA	25.00	0.00	25.00	2.00	27.00	180.00	360.00
	65	Inlet Protection - New Inlet	EA	15.00	0.00	15.00	1.00	16.00	200.00	200.00
								<b>Paving Sub Total (\$)</b>		<b>5,745.29</b>
<b>Storm Sewer</b>	68	Remove Pipe All Sizes All Types	LF	1,155.00	0.00	1,155.00	75.50	1,230.50	11.00	830.50
	71	F&I Pipe w/GB SDR 26 - 8" Dia PVC	LF	70.00	0.00	70.00	21.10	91.10	52.00	1,097.20
	72	F&I Pipe w/GB 12" Dia Reinf Conc	LF	60.00	0.00	60.00	-17.10	42.90	55.00	-940.50
	73	F&I Pipe w/GB 15" Dia Reinf Conc	LF	320.00	0.00	320.00	24.40	344.40	58.00	1,415.20
	74	F&I Pipe w/GB 24" Dia Reinf Conc	LF	108.00	0.00	108.00	1.50	109.50	74.00	111.00
	75	F&I Pipe w/GB 30" Dia Reinf Conc	LF	27.00	0.00	27.00	1.00	28.00	86.00	86.00
	76	F&I Pipe w/GB 60" Dia Reinf Conc	LF	57.00	0.00	57.00	1.00	58.00	260.00	260.00
	77	F&I Pipe Arch Equiv 18" Reinf Conc	LF	45.00	0.00	45.00	-10.60	34.40	58.00	-614.80
	78	F&I Pipe Arch Equiv 24" Reinf Conc	LF	13.00	0.00	13.00	-0.60	12.40	71.00	-42.60
	79	F&I Pipe Arch Equiv 30" Reinf Conc	LF	212.00	0.00	212.00	-10.30	201.70	81.00	-834.30
	80	F&I Pipe Arch Equiv 36" Reinf Conc	LF	257.00	0.00	257.00	-0.70	256.30	106.00	-74.20
	89	Connect Pipe to Exist Pipe	EA	5.00	0.00	5.00	-2.00	3.00	850.00	-1,700.00
								<b>Storm Sewer Sub Total (\$)</b>		<b>-406.50</b>
<b>Street Lights</b>	90	Remove Street Light	EA	17.00	0.00	17.00	-4.00	13.00	410.00	-1,640.00
	91	Remove Base	EA	9.00	0.00	9.00	-1.00	8.00	280.00	-280.00
	92	F&I Base 6' Deep Reinf Conc	EA	8.00	0.00	8.00	-1.00	7.00	400.00	-400.00





CITY OF FARGO  
ENGINEERING DEPARTMENT  
CHANGE ORDER REPORT

Street Lights	93	F&I Innerduct 1.5" Dia	LF	1,506.00	0.00	1,506.00	-37.00	1,469.00	7.00	-259.00
	94	F&I Conductor #6 USE Cu	LF	8,976.00	0.00	8,976.00	-1,815.00	7,161.00	2.00	-3,630.00
	99	F&I Pull Box	EA	3.00	0.00	3.00	3.00	6.00	762.30	2,286.90
										-3,922.10
										Street Lights Sub Total (\$)
Traffic Signals	102	Remove Signal Standard Type V	EA	1.00	0.00	1.00	-1.00	0.00	290.00	-290.00
	105	Remove Foundation Type V	EA	1.00	0.00	1.00	-1.00	0.00	280.00	-280.00
	110	F&I Conduit 2" Dia	LF	566.00	0.00	566.00	40.00	606.00	7.00	280.00
	111	F&I Conduit 4" Dia	LF	256.00	0.00	256.00	-47.00	209.00	8.00	-376.00
	116	F&I Signal Cable AWG 14/2	LF	1,045.00	0.00	1,045.00	42.00	1,087.00	1.15	48.30
	117	F&I Signal Cable AWG 14/20	LF	1,534.00	0.00	1,534.00	22.00	1,556.00	3.30	72.60
										Traffic Signals Sub Total (\$)
Pavement Marking	127	F&I Grooved Plastic Film 4" Wide	LF	400.00	0.00	400.00	1,157.00	1,557.00	6.00	6,942.00
	128	F&I Grooved Plastic Film 8" Wide	LF	823.00	0.00	823.00	179.00	1,002.00	11.00	1,969.00
	129	F&I Grooved Plastic Film 16" Wide	LF	129.00	0.00	129.00	-5.00	124.00	18.00	-90.00
	130	F&I Grooved Plastic Film Message	SF	380.00	0.00	380.00	-72.00	308.00	33.00	-2,376.00
	131	F&I Grooved Plastic Film 24" Wide	LF	256.00	0.00	256.00	80.00	336.00	33.00	2,640.00
	132	F&I Grooved Contrast Film 7" Wide	LF	580.00	0.00	580.00	-429.00	151.00	10.00	-4,290.00
	133	Paint Epoxy Line 6" Wide	LF	202.00	0.00	202.00	-8.00	194.00	8.00	-64.00
	134	Paint Epoxy Line 8" Wide	LF	595.00	0.00	595.00	-319.00	276.00	7.00	-2,233.00
	135	Paint Epoxy Line 16" Wide	LF	110.00	0.00	110.00	-4.00	106.00	14.00	-56.00
	136	Paint Epoxy Message	SF	144.00	0.00	144.00	42.00	186.00	14.00	588.00
	138	* Temporary Pavement Markings	LS	0.00	0.00	0.00	1.00	1.00	3,930.00	3,930.00
	139	* Markup-Temp Markings	LS	0.00	0.00	0.00	1.00	1.00	393.00	393.00
										Pavement Marking Sub Total (\$)
										Grand Total (\$)
										-10,932.93

\* NC Items

Summary

Source Of Funding

Net Amount Change Order # 1 (\$)



CITY OF FARGO  
ENGINEERING DEPARTMENT  
CHANGE ORDER REPORT

Previous Change Orders (\$)	0.00
Original Contract Amount (\$)	2,188,175.79
Total Contract Amount (\$)	2,177,242.86

I hereby accept this order both as to work to be performed and prices on which payment shall be based.

CONTRACT TIME

Current Substantial Completion Date	Current Final Completion Date	Additional Days Substantial Completion	Additional Days Final Completion	New Substantial Completion Date	New Final Completion Date
10/28/2016		0.00	0.00	10/28/2016	

Description

APPROVED

Robert Gibb & Sons

For Contractor

*Greg Hill*  
VP

APPROVED DATE

Department Head

*[Signature]* 10/4/18

Mayor

Attest

REPORT OF ACTION

PUBLIC WORKS PROJECTS EVALUATION COMMITTEE

45

Improvement District No. PR-18-C1 Type: Change Order #1
Location: 25th St S, 2nd Ave S - 12th Ave S Date of Hearing: 10/1/2018

Routing Date
City Commission 10/8/2018
PWPEC File X
Project File Jeremy Engquist

The Committee reviewed the accompanying correspondence from Project Manager, Jeremy Engquist, for Change Order #1 in the amount of \$34,991.04 for additional storm sewer repairs.

Staff is recommending approval of Change Order #1 in the amount of \$34,991.04, bringing the total contract amount to \$1,233,360.14.

On a motion by Bruce Grubb, seconded by Brenda Derrig, the Committee voted to recommend approval of Change Order #1 to Opp Construction.

RECOMMENDED MOTION

Approve Change Order #1 in the amount of \$34,991.04 to Opp Construction.

PROJECT FINANCING INFORMATION:

Recommended source of funding for project: Street Sales Tax Funds
Yes No
Developer meets City policy for payment of delinquent specials N/A
Agreement for payment of specials required of developer N/A
50% escrow deposit required N/A

COMMITTEE

Table with 4 columns: Present, Yes, No, Unanimous. Rows list committee members: Tim Mahoney, Mayor; Nicole Crutchfield, Director of Planning; Steve Dirksen, Fire Chief; Bruce Grubb, City Administrator; Ben Dow, Director of Operations; Steve Sprague, City Auditor; Brenda Derrig, City Engineer; Kent Costin, Finance Director.

ATTEST:

Brenda E. Derrig, P.E.
City Engineer

C: Kristi Olson



ENGINEERING DEPARTMENT  
225 4<sup>th</sup> Street North  
Fargo, North Dakota 58102  
Phone: (701) 241-1545  
Fax: (701) 241-8101  
E-Mail: Feng@FargoND.gov

# Memorandum

**To:** PWPEC  
**From:** Jeremy Engquist, Project Manager  
**Date:** September 20, 2018  
**Re:** Improvement District #PR-18-C1 – Change Order #1

**Background:**

Improvement District #PR-18-C1 is for concrete pavement repairs and incidentals on 25<sup>th</sup> Street South from 2<sup>nd</sup> Avenue South to 12<sup>th</sup> Avenue South. The purpose of the project is to correct deficiencies that have appeared over time. Joint and random spalls, longitudinal and transverse cracking, pavement blowouts, and pavement deterioration are present on this pavement section.

**Change Order #1 for \$34,991.04** –While completing pavement removals on 25<sup>th</sup> Street, we discovered several sinkholes or voids around existing storm sewer structures. Upon further inspections, we discovered the grout was deteriorated and missing around the pipe to structure connections. The purpose of the grout is to seal up the system to prevent the infiltration that causes these sinkholes. There were four existing inlets needing to be re-grouted and repaired, and an inlet and a manhole were in need of full replacement due to excessive deterioration of the structures. To complete the repairs, we had to expose the structures on all sides, which involved removing additional concrete pavement than originally planned. Included in this change order are all costs to remove & replace additional concrete pavement, excavate around and expose the structures to make necessary repairs and/or replacement of structures, and backfill with aggregate material. These unforeseen repairs have increased costs to the project.

No additional days will be required for the additional work.

Attached to this memorandum you will find Change Order #1 totaling \$34,991.04 for the storm sewer repairs.

**Recommended Motion:**

Approve Change Order #1 to Opp Construction for Improvement District #PR-18-C1 totaling \$34,991.04 to be funded by Street Sales Tax Funds.

Original Contract Amount	Change Order #1	New Contract Amount
\$1,198,369.10	\$34,991.04	\$1,233,360.14

JJE/klo  
Attachment  
C: Tom Knakmuhs

*Street Lighting  
Sidewalks*

*Design & Construction  
Traffic Engineering*

*Truck Regulatory  
Flood Plain Mgmt.*

*Mapping & GIS  
Utility Locations*



**CITY OF FARGO  
ENGINEERING DEPARTMENT  
CHANGE ORDER REPORT**

<b>Improvement District No</b>	PR-18-C1	<b>Change Order No</b>	1
<b>Project Name</b>	Concrete Pavement Rehabilitation and Incidentals		
<b>Date Entered</b>	8/14/2018	<b>For</b>	Opp Construction LLC

This change is made under the terms of or is supplemental to your present contract, if and when approved, you are ordered to perform the work in accordance with the additions, changes, or alterations hereinafter described.

**EXPLANATION OF CHANGE:** Change Order #1 - Storm Sewer Repairs

While completing pavement removals on 25th Street, we discovered several sinkholes or voids around existing storm sewer structures. Upon further inspections, we discovered the grout was deteriorated and missing around the pipe to structure connections. The purpose of the grout is to seal up the system to prevent the infiltration that causes these sinkholes. There were four existing inlets needing to be re-grouted and repaired, and an inlet and a manhole were in need of full replacement due to excessive deterioration of the structures. To complete the repairs, we had to expose the structures on all sides, which involved removing additional concrete pavement than originally planned. Included in this Change Order are all costs to remove & replace additional concrete pavement, excavate around and expose the structures to make necessary repairs and/or replacement of structures, and backfill with aggregate material.

Section	Line No	Item Description	Unit	Orig Cont Qty	Prev C/O Qty	Prev Cont Qty	Curr C/O Qty	Tot Cont Qty	Unit Price (\$)	C/O Ext Price (\$)
Paving	5	Rem & Repl Pavement 10.5" Thick Doweled Conc	SY	4,360.00	0.00	4,360.00	120.00	4,480.00	107.50	12,900.00
	69	Extra - StormSewers	LS	0.00	0.00	0.00	1.00	1.00	22,091.04	22,091.04
									<b>Paving Sub Total (\$)</b>	<b>34,991.04</b>

**Summary**

<b>Source Of Funding</b>	Sales Tax Funds - Infrastructure - 420, Special Assessments
<b>Net Amount Change Order # 1 (\$)</b>	
<b>Previous Change Orders (\$)</b>	34,991.04
<b>Original Contract Amount (\$)</b>	0.00
<b>Total Contract Amount (\$)</b>	1,198,369.10
	1,233,360.14

I hereby accept this order both as to work to be performed and prices on which payment shall be based.

**CONTRACT TIME**

Current Substantial Completion Date	Current Final Completion Date	Additional Days Substantial Completion	Additional Days Final Completion	New Substantial Completion Date	New Final Completion Date
09/01/2018	10/01/2018	0.00	0.00	09/01/2018	10/01/2018
<b>Description</b>					



CITY OF FARGO  
ENGINEERING DEPARTMENT  
CHANGE ORDER REPORT

APPROVED

APPROVED DATE

For Contractor

*Janice Straas*

Title

Sr. Project Manager.

Department Head

*[Signature]*

Mayor

10/4/18

Attest

REPORT OF ACTION

PUBLIC WORKS PROJECTS EVALUATION COMMITTEE

46

Improvement District No. SL-17-B1 Type: Change Order #1
Location: Lewis and Clark Elementary School Date of Hearing: 10/1/2018
South High

Routing Date
City Commission 10/8/2018
PWPEC File X
Project File Dave Helland

The Committee reviewed the accompanying correspondence from Project Manager, Dave Helland, for Change Order #1 in the amount of \$30,375.00 for replacing original bid item F&I Luminaire Type "A" with bid alternate 2 - F&I Luminaire Type "D". This change is to increase the light lumen level output around the perimeter of the Lewis and Clark Elementary School and South High.

Staff is recommending approval of Change Order #1 in the amount of \$30,375.00, bringing the total contract amount to \$1,680,215.10.

On a motion by Bruce Grubb, seconded by Brenda Derrig, the Committee voted to recommend approval of Change Order #1 to Moorhead Electric.

RECOMMENDED MOTION

Approve Change Order #1 in the amount of \$30,375.00 to Moorhead Electric.

PROJECT FINANCING INFORMATION:

Recommended source of funding for project: Special Assessments

Developer meets City policy for payment of delinquent specials Agreement for payment of specials required of developer 50% escrow deposit required Yes No N/A N/A N/A

COMMITTEE

Table with 5 columns: Present, Yes, No, Unanimous. Rows list committee members: Tim Mahoney, Mayor; Nicole Crutchfield, Director of Planning; Steve Dirksen, Fire Chief; Bruce Grubb, City Administrator; Ben Dow, Director of Operations; Steve Sprague, City Auditor; Brenda Derrig, City Engineer; Kent Costin, Finance Director.

ATTEST:

Brenda E. Derrig, P.E. City Engineer

C: Kristi Olson



ENGINEERING DEPARTMENT  
225 4<sup>th</sup> Street North  
Fargo, North Dakota 58102  
Phone: (701) 241-1545  
Fax: (701) 241-8101  
E-Mail: Feng@FargoND.gov

# Memorandum

**To:** Members of PWPEC  
**From:** Dave Helland, Project Manager  
**Date:** September 26, 2018  
**Re:** Improvement District SL-17-B1 – Change Order #1

**Background:**

Improvement District SL-17-B1 is for street lighting, and incidentals in the Lewis and Clark neighborhood.

The attached Change Order # 1 includes replacing (81) original bid item F & I Luminaire Type "A" with bid alternate 2 – F & I Luminaire Type "D". This change will increase the light lumen level output around the perimeter of the Lewis and Clark Elementary School and South High.

No additional days were required to complete the work.

**Recommended Motion:**

Approve Change Order # 1 in the amount of \$30,375.00.

DJH/klo  
Attachment

*Street Lighting  
Sidewalks*

*Design & Construction  
Traffic Engineering*

*Truck Regulatory  
Flood Plain Mgmt.*

*Mapping & GIS  
Utility Locations*





**CITY OF FARGO  
ENGINEERING DEPARTMENT  
CHANGE ORDER REPORT**

Improvement District No SL-17-B1 Change Order No 1  
 Project Name Street Lighting & Incidentals  
 Date Entered 8/23/2018 For Moorhead Electric

This change is made under the terms of or is supplemental to your present contract , if and when approved, you are ordered to perform the work in accordance with the additions, changes, or alterations hereinafter described.

**EXPLANATION OF CHANGE:** Bid Alternate 2 - Furnish and install luminaire type "A"

Replaced 81 original bid items with different style luminaire

Section	Line No	Item Description	Unit	Orig Cont Qty	Prev C/O Qty	Prev Cont Qty	Curr C/O Qty	Tot Cont Qty	Unit Price (\$)	C/O Ext Price (\$)
Street Lighting	5	F&I Luminaire Type A	EA	394.00	0.00	394.00	-81.00	313.00	455.00	-36,855.00
	19	F&I Luminaire Type D	EA	0.00	0.00	0.00	81.00	81.00	830.00	67,230.00
									<b>Street Lighting Sub Total (\$)</b>	<b>30,375.00</b>

**Summary**

Source Of Funding Special Assessments

Net Amount Change Order # 1 (\$)  
 Previous Change Orders (\$)  
 Original Contract Amount (\$)  
 Total Contract Amount (\$)

I hereby accept this order both as to work to be performed and prices on which payment shall be based.

**CONTRACT TIME**

Current Substantial Completion Date	10/01/2018	Additional Days Substantial Completion	0.00	New Substantial Completion Date	10/01/2018
Current Final Completion Date		Additional Days Final Completion	0.00	New Final Completion Date	

Description

**APPROVED** APPROVED DATE



CITY OF FARGO  
ENGINEERING DEPARTMENT  
CHANGE ORDER REPORT

For Contractor

Modhead Electric

Title

*[Signature]*  
Project Manager  
08/23/2018

Department Head

*[Signature]*

Mayor

10/4/18

Attest

PUBLIC WORKS PROJECTS EVALUATION COMMITTEE

47

Improvement District No. BN-18-A1 Type: Time Extension (CO#1)

Location: Bison Meadows (Phase II) Date of Hearing: 10/1/2018

<u>Routing</u>	<u>Date</u>
City Commission	10/8/2018
PWPEC File	X
Project File	Jason Leonard

The Committee reviewed the accompanying correspondence from Project Manager, Jason Leonard, regarding a time extension for KPH due to unsuitable soil for LOMR fill use.

Due to the delay, City staff along with the Developer have decided to split the project into two phases to help expedite the completion and make lots available for the Developer this fall. The revisions are for an Interim Completion Date of October 15, 2018 to complete LOMR and street work with boundaries between 68th Ave S and 70th Ave S and west of 15th St. The revised Substantial Completion Date will be November 1, 2018 and a Final Completion Date will be May 1, 2018.

Staff is recommending approval of the time extension as described.

On a motion by Bruce Grubb, seconded by Brenda Derrig, the Committee voted to recommend approval of the time extension (CO #1) as described above.

RECOMMENDED MOTION

Concur with the recommendations of PWPEC and approve the time extension (CO #1).

PROJECT FINANCING INFORMATION:

Recommended source of funding for project: Cass Rural WUD Funds & Special Assessments

	<u>Yes</u>	<u>No</u>
Developer meets City policy for payment of delinquent specials	N/A	
Agreement for payment of specials required of developer	N/A	
Letter of Credit required (per policy approved 5-28-13)	N/A	

COMMITTEE

	<u>Present</u>	<u>Yes</u>	<u>No</u>	<u>Unanimous</u>
				<input checked="" type="checkbox"/>
Tim Mahoney, Mayor	<input checked="" type="checkbox"/>	<input checked="" type="checkbox"/>	<input type="checkbox"/>	
Nicole Crutchfield, Director of Planning	<input checked="" type="checkbox"/>	<input checked="" type="checkbox"/>	<input type="checkbox"/>	
Steve Dirksen, Fire Chief	<input checked="" type="checkbox"/>	<input checked="" type="checkbox"/>	<input type="checkbox"/>	
Bruce Grubb, City Administrator	<input checked="" type="checkbox"/>	<input checked="" type="checkbox"/>	<input type="checkbox"/>	
Ben Dow, Director of Operations	<input checked="" type="checkbox"/>	<input checked="" type="checkbox"/>	<input type="checkbox"/>	
Steve Sprague, City Auditor	<input checked="" type="checkbox"/>	<input checked="" type="checkbox"/>	<input type="checkbox"/>	
Brenda Derrig, City Engineer	<input checked="" type="checkbox"/>	<input checked="" type="checkbox"/>	<input type="checkbox"/>	
Kent Costin, Finance Director	<input type="checkbox"/>	<input type="checkbox"/>	<input type="checkbox"/>	

ATTEST:

  
Brenda E. Derrig, P.E.  
City Engineer

C: Kristi Olson



ENGINEERING DEPARTMENT  
225 4<sup>th</sup> Street North  
Fargo, North Dakota 58102  
Phone: (701) 241-1545  
Fax: (701) 241-8101  
E-Mail: Feng@FargoND.gov

# Memorandum

**To:** PWPEC  
**From:** Jason Leonard, Civil Engineer II  
**C:** Tom Knakmuhs, Division Engineer  
**Date:** 9/27/18  
**Re:** Improvement District # BN-18-A1 – Time Extension (CO #1)

Project BN-18-A1 was bid on May 2, 2018 with bid award on May 7, 2018. The project documents identified Substantial Completion for all work on September 15, 2018 and Final Completion for all cleanup and punch list items for October 15, 2018. KPH, Inc. was awarded the project and subsequently given a notice to proceed. Excess excavated material to complete the design geometry of the west pond on ID # FM-17-C1 was to be stockpiled for use on project BN-18-A1. The pre-construction meeting for projects FM-17-C1 and BN-18-A1 was held on May 22, 2018. A meeting on site was held on August 23, 2018. The meeting was to review the wet condition of the borrow soils in the pond and to determine if the wet soils were suitable for LOMR fill use on Bison Meadows site grading. In a letter dated August 27, 2018, from testing firm NTI for the LOMR fill work under BN-18-A1, advised the City and Developer that the fill planned to come from the Bison Meadows Area west pond was deemed unsuitable for LOMR fill use. A solution was found to use higher elevation soils from around the ponds to complete the LOMR work. With this finding of unsuitable material, the Contractor for ID # FM-17-C1 was granted a 20 day time extension to over excavate areas to provide fill for ID # BN-18-A1.

With the delay incurred by the Contractor on ID # BN-17-A1 due to fill material not supplied to complete the LOMR fill work under the contract, City staff along with the support of the Developer decided to split the project into two phases to help expedite the completion of the project and make lots available for the Developer this fall. The revision incorporates an Interim Completion date of October 15, 2018 to complete the LOMR and street work in the boundaries between 68<sup>th</sup> Avenue and 70<sup>th</sup> Avenue South and west of 15<sup>th</sup> Street South. The revised project Substantial Completion date will be November 1, 2018 and a Final Completion date of May 1, 2018.

Recommended Motion

Approve Change Order #1 for the time extension.

JTL/klo  
Attachment



**CITY OF FARGO  
ENGINEERING DEPARTMENT  
CHANGE ORDER REPORT**

<b>Improvement District No</b>	BN-18-A1	<b>Change Order No</b>	1
<b>Project Name</b>	Sanitary Sewer, Water Main, Storm Sewer, Paving, Street Lights & Incidentals		
<b>Date Entered</b>	9/27/2018	<b>For</b>	KPH, Inc.

This change is made under the terms of or is supplemental to your present contract, if and when approved, you are ordered to perform the work in accordance with the additions, changes, or alterations hereinafter described.

**EXPLANATION OF CHANGE:**

Section	Line No	Item Description	Unit	Orig Cont Qty	Prev C/O Qty	Prev Cont Qty	Curr C/O Qty	Tot Cont Qty	Unit Price (\$)	C/O Ext Price (\$)
<b>Summary</b>										
<b>Source Of Funding</b>										
<b>Net Amount Change Order # 1 (\$)</b>										0.00
<b>Previous Change Orders (\$)</b>										2,075,244.22
<b>Original Contract Amount (\$)</b>										2,075,244.22
<b>Total Contract Amount (\$)</b>										

I hereby accept this order both as to work to be performed and prices on which payment shall be based.

**CONTRACT TIME**

Current Substantial Completion Date	Current Final Completion Date	Additional Days Substantial Completion	Additional Days Final Completion	New Substantial Completion Date	New Final Completion Date
09/15/2018		47.00	0.00	11/01/2018	
<b>Description</b>	With the delay incurred by the Contractor on ID # BN-17-A1 due to fill material not supplied to complete the LOMR fill work under the contract, city staff along with the support of the developer decided to split the project into two phases to help expedite the completion of the project and make lots available for the developer this fall. The revision incorporates an interim completion date of October 15, 2018 to complete the LOMR and street work in the boundaries between 68th Avenue and 70th Avenue South and west of 15th Street South. The revised project substantial completion date will be November 1, 2018 and a final completion date of May 1st, 2018.				



CITY OF FARGO  
ENGINEERING DEPARTMENT  
CHANGE ORDER REPORT

APPROVED

*[Signature]*  
President

For Contractor

Title

APPROVED DATE

*[Signature]*  
Department Head  
Mayor  
10/4/18

Attest

REPORT OF ACTION

PUBLIC WORKS PROJECTS EVALUATION COMMITTEE

48

Improvement District No. DN-18-A1

Type: Utility Relocation

Location: Drain 27

Date of Hearing: 10/1/2018

<u>Routing</u>	<u>Date</u>
City Commission	<u>10/8/2018</u>
PWPEC File	<u>X</u>
Project File	<u>Roger Kluck</u>

The Committee reviewed a communication from Project Engineer, Roger Kluck, regarding a utility relocation starting at Drain 27, south of 52 Ave S. Cable One has estimated the cost to be \$14,707.38 to relocate their existing fiber wire. Funding for this utility relocation will be 72.35% from the Water Utility and 27.65% from Special Assessments.

Troy Hall, the Water Utility Director, has been consulted regarding the cost of the relocations. Staff is recommending approval.

On a motion by Bruce Grubb, seconded by Ben Dow, the Committee voted to approve the utility relocation and authorize payment to Cable One in the amount of \$14,707.38.

RECOMMENDED MOTION

Concur with the recommendations of PWPEC to approve the utility relocation and authorize payment to Cable One in the amount of \$14,707.38.

PROJECT FINANCING INFORMATION:

Recommended source of funding for project: Water Utility Funds & Special Assessments

	<u>Yes</u>	<u>No</u>
Developer meets City policy for payment of delinquent specials	<u>N/A</u>	<u>      </u>
Agreement for payment of specials required of developer	<u>N/A</u>	<u>      </u>
Letter of Credit required (per policy approved 5-28-13)	<u>N/A</u>	<u>      </u>

COMMITTEE

	<u>Present</u>	<u>Yes</u>	<u>No</u>	<u>Unanimous</u>
Tim Mahoney, Mayor	<input checked="" type="checkbox"/>	<input checked="" type="checkbox"/>	<input type="checkbox"/>	<input checked="" type="checkbox"/>
Nicole Crutchfield, Director of Planning	<input checked="" type="checkbox"/>	<input checked="" type="checkbox"/>	<input type="checkbox"/>	
Steve Dirksen, Fire Chief	<input checked="" type="checkbox"/>	<input checked="" type="checkbox"/>	<input type="checkbox"/>	
Bruce Grubb, City Administrator	<input checked="" type="checkbox"/>	<input checked="" type="checkbox"/>	<input type="checkbox"/>	
Ben Dow, Director of Operations	<input checked="" type="checkbox"/>	<input checked="" type="checkbox"/>	<input type="checkbox"/>	
Steve Sprague, City Auditor	<input checked="" type="checkbox"/>	<input checked="" type="checkbox"/>	<input type="checkbox"/>	
Brenda Derrig, City Engineer	<input checked="" type="checkbox"/>	<input checked="" type="checkbox"/>	<input type="checkbox"/>	
Kent Costin, Finance Director	<input checked="" type="checkbox"/>	<input checked="" type="checkbox"/>	<input type="checkbox"/>	

ATTEST:

C: Kristi Olson

  
 Brenda E. Derrig, P.E.  
 City Engineer



ENGINEERING DEPARTMENT  
225 4<sup>th</sup> Street North  
Fargo, North Dakota 58102  
Phone: (701) 241-1545  
Fax: (701) 241-8101  
E-Mail: Feng@FargoND.gov

# Memorandum

**To:** PWPEC  
  
**From:** Roger E. Kluck, PE, CFM Civil Engineer II  
  
**Date:** 10/01/18  
  
**Re:** **Project No. DN-18-A1 Drain 27 Improvements and Incidentals  
Cable One Utility relocation**

Project No. DN-18-A1 improves an existing drainage ditch starting at Drain 27, south of 53<sup>rd</sup> Ave S. The ditch improvements go west thru 63<sup>rd</sup> St S over to Grayland Addition. The second phase of this project will be bid early this fall to install a pumping station on this improved ditch at Drain 27 for flood control during high water times on Drain 27. These are the first of several projects that will provide improved drainage control in this developing area and will be coupled with pumped water from the Sheyenne River to provide drinking water for Fargo and the region in times of low flow on the Red River. Project No. DN-18-A1 includes a box culvert structure thru 63<sup>rd</sup> Street South that will require the relocation of private utilities contained in a 30-foot wide utility easement.

The attached cost information is from Cable One and covers their cost to relocate their existing fiber wire along 63<sup>rd</sup> Avenue, south of 52<sup>nd</sup> Ave S at the crossing with the new drainage ditch. Cable One has provided a proposal to complete this necessary work, which is estimated to be \$14,707.38. For your review, the proposal is attached with this memo. The total cost submitted for utility relocations on this project is Century Link \$22,420.48, Midco \$9,500.00, Cable One \$14,707.38 totaling \$46,627.86. The only other utility we are dealing with is Xcel Gas, which has indicated they do not plan to charge to cut and relay their line over the box culvert.

Funding for this utility relocation will be 72.35% from the Water Utility and 27.65% from Special Assessments. Troy Hall, the Water Utility Director has been consulted on these relocation costs and agrees to proceeding with the relocation work.

Recommended Motion

Approve payment of \$14,707.38 to Cable One for the relocation of existing fiber wire along 63<sup>rd</sup> Street South.

REK/jmg  
Attachment

C: Jody Bertrand, Division Engineer  
Tom Knakmuhs, Division Engineer  
Troy Hall, Water Utility Director

*Street Lighting  
Sidewalks*

*Design & Construction  
Traffic Engineering*

*Truck Regulatory  
Flood Plain Mgmt.*

*Mapping & GIS  
Utility Locations*



## Roger Kluck

---

**From:** Muir, David <David.Muir@cableone.biz>  
**Sent:** Friday, September 21, 2018 5:02 PM  
**To:** Roger Kluck  
**Subject:** RE: DN-18-A1 63rd/Dr 27 crossing Cable One

**CAUTION:** This email originated from an outside source. Do not click links or open attachments unless you know they are safe.

Roger,

Cable One's fiber line in the path of this drain looks to cost \$14,707.38, this will bore in a new duct, repull and resplice the existing fiber vault to vault.

Thanks,

Dave Muir  
Construction Coordinator  
Cable One, Inc.  
1024 Page Dr. Fargo, ND 58103  
Office (701) 461-7044 Cell (701) 219-6485  
[david.muir@cableone.biz](mailto:david.muir@cableone.biz)

**From:** Roger Kluck <rkluck@FargoND.gov>  
**Sent:** Monday, August 13, 2018 3:34 PM  
**To:** Muir, David <David.Muir@cableone.biz>  
**Cc:** Brian Gaddie <Brian.Gaddie@AE2S.com>; Jody Bertrand <JBertrand@FargoND.gov>  
**Subject:** RE: DN-18-A1 63rd/Dr 27 crossing Cable One

Ground is 905 and flow line of box is 897.42 and toe wall is 893.5. You will need to be below toe wall as located.

**Roger E. Kluck, PE, CFM**  
Engineer II Storm Water  
City of Fargo  
200 N 3<sup>rd</sup> Street  
Fargo, ND 58102

701- 241-1537(work)  
701-361-5354 (cell)  
[rkluck@FargoND.gov](mailto:rkluck@FargoND.gov)

**From:** Muir, David <David.Muir@cableone.biz>  
**Sent:** Monday, August 13, 2018 3:28 PM  
**To:** Roger Kluck <rkluck@FargoND.gov>  
**Subject:** RE: DN-18-A1 63rd/Dr 27 crossing Cable One

**CAUTION:** This email originated from an outside source. Do not click links or open attachments unless you know they are safe.

Roger,

Can you tell me a depth you would like it placed?

Thanks,

Dave Muir  
Construction Coordinator  
Cable One, Inc.  
1024 Page Dr. Fargo, ND 58103  
Office (701) 461-7044 Cell (701) 219-6485  
david.muir@cableone.biz

**From:** Roger Kluck <[rkluck@FargoND.gov](mailto:rkluck@FargoND.gov)>  
**Sent:** Monday, August 13, 2018 3:26 PM  
**To:** Muir, David <[David.Muir@cableone.biz](mailto:David.Muir@cableone.biz)>  
**Subject:** RE: DN-18-A1 63rd/Dr 27 crossing Cable One

It can be replaced where is just lower.

**Roger E. Kluck, PE, CFM**  
Engineer II Storm Water  
City of Fargo  
200 N 3<sup>rd</sup> Street  
Fargo, ND 58102

701- 241-1537(work)  
701-361-5354 (cell)  
[rkluck@FargoND.gov](mailto:rkluck@FargoND.gov)

**From:** Muir, David <[David.Muir@cableone.biz](mailto:David.Muir@cableone.biz)>  
**Sent:** Monday, August 13, 2018 3:20 PM  
**To:** Roger Kluck <[rkluck@FargoND.gov](mailto:rkluck@FargoND.gov)>  
**Subject:** RE: DN-18-A1 63rd/Dr 27 crossing Cable One

**CAUTION:** This email originated from an outside source. Do not click links or open attachments unless you know they are safe.

Roger,

How much can you tell me on where we need to relocate the line to?

Can it be replaced where it is, but higher or lower? The more I can find out the faster and more accurate I can get you costs.

Thanks,

Dave Muir  
Construction Coordinator  
Cable One, Inc.  
1024 Page Dr. Fargo, ND 58103  
Office (701) 461-7044 Cell (701) 219-6485  
david.muir@cableone.biz

**From:** Roger Kluck <rkluck@FargoND.gov>

**Sent:** Monday, August 13, 2018 12:58 PM

**To:** Brenneman, Bryon <Bryon.Brenneman@cableone.biz>; Miller, Carin <Carin.Miller@cableone.biz>; Muir, David <David.Muir@cableone.biz>

**Cc:** Brian Gaddie <Brian.Gaddie@AE2S.com>; Jody Bertrand <JBertrand@FargoND.gov>

**Subject:** FW: DN-18-A1 63rd/Dr 27 crossing Cable One

Here are the final plans for the Drain 27 reconstruction that includes work on 63rd St S. The project is slated for bid September 5. I would like to send my memo of costs to PWPEC this Wednesday. Looking at the plans our project is going to affect your line and with it will need to be moved/adjusted. Please provide your costs for this move by Wednesday so they can go up for approval. I would expect that the relocation work will need to be done this fall. Depending on culvert fabrication the 63rd work will be done late this fall or in the early spring before June 15, 2019. Thank you.

**Roger E. Kluck, PE, CFM**

Engineer II Storm Water  
City of Fargo  
200 N 3<sup>rd</sup> Street  
Fargo, ND 58102

701- 241-1537(work)

701-361-5354 (cell)

rkluck@FargoND.gov

PUBLIC WORKS PROJECTS EVALUATION COMMITTEE

401

Improvement District No. BN-19-A1  
SU-8-984(164)

Type: Approval of Project into 2019 CIP

Location: 52<sup>nd</sup> Ave S from 45<sup>th</sup> St to 63<sup>rd</sup> St

Date of Hearing: 10/1/2018

<u>Routing</u>	<u>Date</u>
City Commission	<u>10/8/2018</u>
PWPEC File	<u>X</u>
Project File	<u>Jeremy Gorden</u>

The committee reviewed communication from Transportation Division Engineer, Jeremy Gorden, regarding this project. Staff is seeking early approval for a project to be included in the 2019 CIP. Project BN-19-A1 is for the reconstruction of 52<sup>nd</sup> Ave S from 45<sup>th</sup> St to 63<sup>rd</sup> St. The project will consist of a 4-lane road section with center median, removing the existing bridge over Drain 27 and replacing it with two new bridges, installing new traffic signal at Veterans and potentially one at 63<sup>rd</sup> St, converting 47<sup>th</sup> St, 53<sup>rd</sup> St, and 53<sup>rd</sup> Ave S intersections into RCUT intersections for improved safety, constructing shared use paths on both sides of the avenue throughout the project limits, and installing new street lights. Engineering services for the project were approved and included in the 2018 CIP.

Funding for the project will consist of Federal Highway Funds from the NDDOT's Urban Roads Program (Federal), City of West Fargo Funds, Cass County Highway Department Funds, Southeast Cass Water Resource District Funds, and City of Fargo Special Assessment Funds.

The Committee had discussion regarding the Special Assessments and the task force. An updated Engineer's Report could reflect any changes with the Special Assessment Policy.

On a motion by Brenda Derrig, seconded by Nicole Crutchfield, the Committee voted to recommend early approval of Improvement District BN-19-A1, for the reconstruction of 52<sup>nd</sup> Ave S from 45<sup>th</sup> St to 63<sup>rd</sup> St, to the 2019 CIP.

RECOMMENDED MOTION

Concur with the recommendations of PWPEC and approve the early entry of Improvement District BN-19-A1 to the 2019 CIP.

PROJECT FINANCING INFORMATION:

Recommended source of funding for project: Federal, SE Cass Water Resource District, Cass Cty Hwy, City of West Fargo & City of Fargo Special Assessments

Developer meets City policy for payment of delinquent specials  
Agreement for payment of specials required of developer  
Letter of Credit required (per policy approved 5-28-13)

Yes	No
<u>N/A</u>	
<u>N/A</u>	
<u>N/A</u>	

COMMITTEE

- Tim Mahoney, Mayor
- Nicole Crutchfield, Director of Planning
- Steve Dirksen, Fire Chief
- Bruce Grubb, City Administrator
- Ben Dow, Director of Operations
- Steve Sprague, City Auditor
- Brenda Derrig, City Engineer
- Kent Costin, Finance Director

<u>Present</u>	<u>Yes</u>	<u>No</u>	<u>Unanimous</u>
<input type="checkbox"/>	<input type="checkbox"/>	<input type="checkbox"/>	<input checked="" type="checkbox"/>
<input checked="" type="checkbox"/>	<input checked="" type="checkbox"/>	<input type="checkbox"/>	
<input checked="" type="checkbox"/>	<input checked="" type="checkbox"/>	<input type="checkbox"/>	
<input checked="" type="checkbox"/>	<input checked="" type="checkbox"/>	<input type="checkbox"/>	
<input checked="" type="checkbox"/>	<input checked="" type="checkbox"/>	<input type="checkbox"/>	
<input checked="" type="checkbox"/>	<input checked="" type="checkbox"/>	<input type="checkbox"/>	
<input checked="" type="checkbox"/>	<input checked="" type="checkbox"/>	<input type="checkbox"/>	

ATTEST:

C: Kristi Olson

B. E. Derrig  
Brenda E. Derrig, P.E.  
City Engineer

## Memorandum

**To:** Members of PWPEC

**From:** Jeremy M. Gorden, PE, PTOE  
 Division Engineer-Transportation

**Date:** September 26, 2018

**Subject:** Early Approval of Project to be included with 2019 Capital Improvement Plan  
 52<sup>nd</sup> Avenue S from 45<sup>th</sup> Street to 63<sup>rd</sup> Street  
 Improvement District No. BN-19-A  
 NDDOT Project No. SU-8-984(164)

Since this project hasn't officially been included with a CIP, I'd like to get early approval of it to be included as part of the 2019 CIP. This project bids on November 9<sup>th</sup> in Bismarck.

This project is for the reconstruction of 52<sup>nd</sup> Avenue S from 45<sup>th</sup> Street to 63<sup>rd</sup> Street. The project will consist of a 4-lane road section with center median, removing the existing bridge over Drain 27 and replacing it with two new bridges, installing new traffic signal at Veterans and potentially one at 63<sup>rd</sup> Street (pending NDDOT approval), converting 47<sup>th</sup> Street, 53<sup>rd</sup> Street, and 53<sup>rd</sup> Avenue S intersections to RCUT intersections (reduced conflict U-turn intersections) for improved safety, constructing shared use paths on both sides of the avenue throughout the project limits, and installing new street lighting.

The engineering services for this project was approved by the Fargo City Commission under the 2018 Capital Improvements Program (CIP) and the project's federally mandated environmental document was approved by the Fargo City Commission in April.

The estimated construction cost is approximately \$14,564,414. Funding for the project will consist of Federal Highway Funds from the NDDOT's Urban Roads Program (Federal), City of West Fargo Funds, Cass County Highway Department Funds, Southeast Cass Water Resource District Funds, and City of Fargo Special Assessment Funds. The project's construction cost breakout is as follows:

Estimated Construction Cost	\$ 14,564,414
Funding (including engineering and fees)	
Federal - Urban Roads Program funds	\$ 9,349,354
SE Cass Water Resource District	\$ 486,000
Cass County Highway Department	\$ 1,400,000
City of West Fargo	\$ 195,000
Fargo funds	\$ 6,885,575

This project is ready to be placed on the City Commission agenda for project creation and creation of Special Assessment District.

**Recommended Motion**

Approval early entry into the 2019 CIP for the 52<sup>nd</sup> Avenue S project from 45<sup>th</sup> Street to 63<sup>rd</sup> Street - Improvement District No. BN-19-A.

**Attachment**

- |                        |                                  |                          |                          |
|------------------------|----------------------------------|--------------------------|--------------------------|
| <i>Street Lighting</i> | <i>Design &amp; Construction</i> | <i>Truck Regulatory</i>  | <i>Mapping &amp; GIS</i> |
| <i>Sidewalks</i>       | <i>Traffic Engineering</i>       | <i>Flood Plain Mgmt.</i> | <i>Utility Locations</i> |

DESIGN DATA	
Traffic	Average Daily
Current 2015	Pass: 11,365 Trucks: 475 Total: 11,840
Forecast 2040	Pass: 19,775 Trucks: 825 Total: 20,600
Clear Zone Distance: 28 FT	Design Speed: 45 MPH
Minimum Sight Dist. for Stopping: 360 FT	Bridges: HL-93
Limited Access Control	
Pavement Design Life: 30 YEARS	
Design Accumulated One-way Rigid ESALS: N/A	

**JOB # 2**  
**NORTH DAKOTA**  
**DEPARTMENT OF TRANSPORTATION**

**SU-8-984(164)**  
**BN-19-A1**

CASS COUNTY  
52nd AVE S

WEST OF 63rd ST S TO 45th ST S  
GRADING, SALVAGED BASE, PCC PAVEMENT, HMA, STORM DRAIN,  
LIGHTING, SIGNALS, PAVEMENT MARKING, SHARED USE PATH,  
REINF. CONCRETE SIDEWALK, BRIDGE, AND WATER MAIN

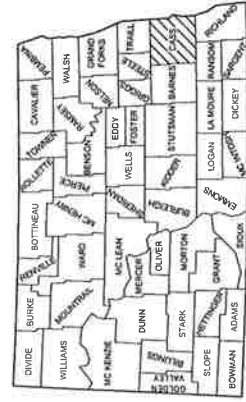
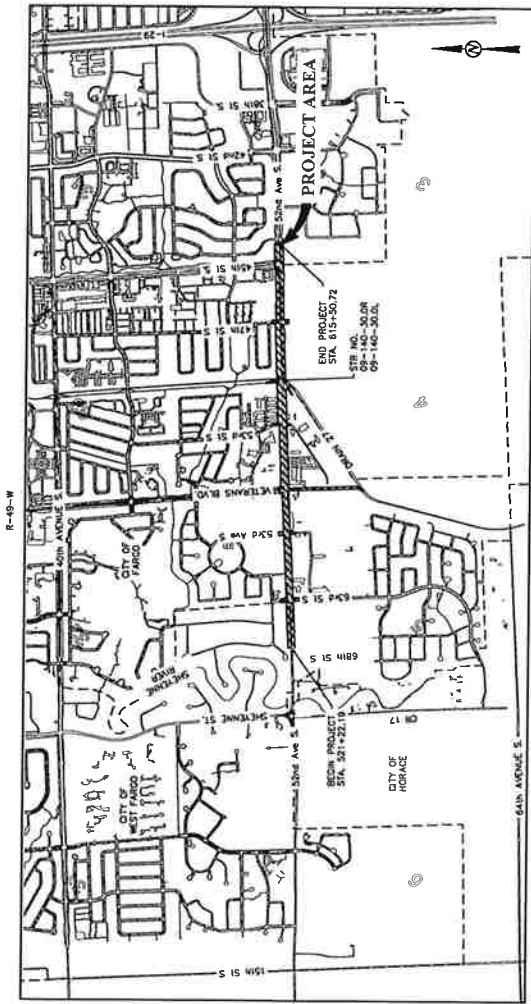

DESIGNERS
Adam Ruud PE
Cole Wagner PE
Josh Hinds PE
Gabriel Bledow PE
Mike Shomton PE
Erik Seiberlich PE

STATE	ND	PROJECT NO.	SU-8-984(164)	PCN	22007	SECTION NO.	1	SHEET NO.	1
-------	----	-------------	---------------	-----	-------	-------------	---	-----------	---

**GOVERNING SPECIFICATIONS:**

2014 Standard Specifications adopted by the North Dakota Department of Transportation and the Supplemental Specifications effective on the date the project is advertised.

PROJECT NUMBER	DESCRIPTION	NET MILES	GROSS MILES
SU-8-984(164)		1.786	1.786



Prof. No. 6059-0145  
**Houston Engineering Inc.**  
Ph: 701.237.5065

I hereby certify that the attached plans were prepared by me or under my direct supervision and that I am a duly registered professional engineer under the laws of the state of ND.

APPROVED DATE 8/15/18  
Jeremy L. McLaughlin /s/  
HOUSTON ENGINEERING INC

This document was originally issued and sealed by  
Jeremy L. McLaughlin  
Registration Number 4883  
on 8/15/18 and the original document is stored in the Engineering Dept. at City Hall.

APPROVED DATE 8/15/18  
Brenda Derrig /s/  
FARGO CITY ENGINEER

STATE COUNTY MAP

COVER SHEET  
CITY OF FARGO PROJECTS

50

This sheet must be completed and turned in with all City of Fargo projects. NO items will be accepted by either the City Commission Office or the City Auditor's Office without this cover sheet attached and properly filled out.

Exact, full name of Improvement District as it will appear in the Contract:

GRADING, SALVAGED BASE, PC CONCRETE PAVEMENT, HOT MIX ASPHALT, STORM DRAIN, STREET LIGHTING, TRAFFIC SIGNALS, PAVEMENT MARKING, SHARED USE PATH, SIDEWALK, BRIDGE, WATER MAIN & INCIDENTALS

Improvement District No. BN-19-A

Call For Bids	<u>October 8</u>	, <u>2018</u>
Advertise Dates	<u>October 15 &amp; 22</u>	, <u>2018</u>
Bid Opening Date	<u>(NDDOT) November 9</u>	, <u>2018</u>
Substantial Completion Date	<u>October 25</u>	, <u>2019</u>
Final Completion Date	<u>November 25</u>	, <u>2019</u>

- X PWPEC Report
- X Engineer's Report (Attach Copy)
- N/A Direct City Auditor to Advertise for Bids (to be bid by NDDOT)
- N/A Bid Quantities (Attach Copy for Auditor's Office Only)
- X Notice to Property Owners (Dan Eberhardt)

Project Engineer Jeremy Gorden

Phone No. 241-1545

The items listed above are for use on all City projects. The additional items listed below are to be checked only when all or part of a project is to be special assessed:

- X Create District (Attach Copy of Legal Description)
- X Order Plans & Specifications
- X Approve Plans & Specifications
- X Adopt Resolution of Necessity
- N/A Approve Escrow Agreement (Attach Copy for Commission Office Only)
- X Assessment Map (Attach Copy for Auditor's Office Only)

## ENGINEER'S REPORT

GRADING, SALVAGED BASE, PC CONCRETE PAVEMENT, HOT MIX ASPHALT, STORM DRAIN, STREET LIGHTING, TRAFFIC SIGNALS, PAVEMENT MARKING, SHARED USE PATH, SIDEWALK, BRIDGE, WATER MAIN & INCIDENTALS

IMPROVEMENT DISTRICT NO. BN-19-A

### **Nature and Scope**

This project is for the reconstruction of 52nd Avenue South from 45th Street to 63rd Street. The project will consist of a 4-lane road section with center median, removing the existing bridge over Drain 27 and replacing it with two new bridges, installing new traffic signal at Veterans and potentially one at 63rd Street (pending NDDOT approval), converting 47th Street, 53rd Street, and 53rd Avenue South intersections to RCUT intersections (reduced conflict U-turn intersections) for improved safety, constructing shared use paths on both sides of the avenue throughout the project limits, and installing new street lighting.

The engineering services for this project were approved by the Fargo City Commission under the 2018 Capital Improvements Program (CIP) and the project's federally mandated environmental document was approved by the Fargo City Commission in April.

### **Purpose**

52<sup>nd</sup> Avenue South is functionally classified as a major arterial roadway. The purpose of the project is to reconstruct and improve 52nd Ave South from 45<sup>th</sup> Street to 63<sup>rd</sup> Street to serve as an important link in the multimodal transportation system. Thereby, accommodating the long-term growth and development within the project area by addressing capacity needs, level of service (LOS), pavement condition and pedestrian infrastructure.

### **Feasibility**

The estimated construction cost is approximately \$14,564,414. Funding for the project will consist of Federal Highway Funds from the NDDOT's Urban Roads Program (Federal), City of West Fargo Funds, Cass County Highway Department Funds, Southeast Cass Water Resource District Funds, and City of Fargo Special Assessment Funds. The project's construction cost breakout is as follows:



**Estimated Construction Cost:** **\$ 14,564,414**

**Estimated Fargo Share of Construction:** **\$ 3,188,904**

In-House Engineering (7%)	\$ 223,223
Administration (6%)	\$ 191,334
Legal/Miscellaneous (3%)	\$ 95,667
Interest (4%)	\$ 127,556
Contingency (10%)	\$ 318,890

**Plus Special Items:**

Right-of-Way	\$ 750,000
Utility Relocations	\$ 750,000
Consulting Engineering Fee – Preliminary and Final Design	\$ 935,000
Consulting Engineering Fee – Construction Services	<u>\$ 250,000</u>
<b>Total Estimated Assessed Street Reconstruction Cost</b>	<b>\$ 6,830,575</b>

**Estimated Project Cost:** **\$ 18,261,085**

**Project Funding Summary:**

Federal Highway Funds – NDDOT Urban Roads Fund	\$ 9,349,354
SE Cass Water Resource District	\$ 486,156
Cass County Highway Department	\$ 1,400,000
City of West Fargo	\$ 195,000
Special Assessments – Street Reconstruction	\$ 6,830,575

Costs will be special assessed according to City policy.

We believe this project to be cost effective.

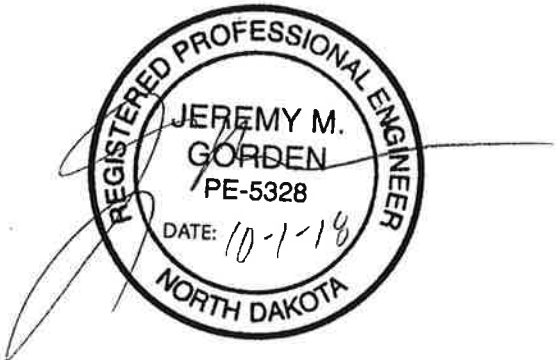

  
 \_\_\_\_\_  
 Jeremy M. Gorden, PE, PTOE  
 Division Engineer - Transportation

CITY OF FARGO  
ENGINEERING DEPARTMENT

LOCATION AND COMPRISING

GRADING, SALVAGED BASE, PC CONCRETE PAVEMENT, HOT MIX ASPHALT,  
STORM DRAIN, STREET LIGHTING, TRAFFIC SIGNALS, PAVEMENT MARKING,  
SHARED USE PATH, SIDEWALK, BRIDGE, WATER MAIN & INCIDENTALS

IMPROVEMENT DISTRICT NO. BN-19-A

**LOCATION:**

On 52<sup>nd</sup> Avenue South from 45<sup>th</sup> Street South to 63<sup>rd</sup> Street South.  
On Drain 27 and 52<sup>nd</sup> Avenue South Bridge Crossings.

**COMPRISING:**

Bounded on the north at the 1/4 Section lines of Section 32 and Section 33, Township 139 North, Range 49 West.

Bounded on the south at the Municipal Boundary, 64<sup>th</sup> Avenue South and the 1/4 Section line of Section 4, Township 138 North, Range 49 West.

Bounded on the west at the Municipal Boundary and 1/4 Section line of Section 32, Township 139 North, Range 49 West, at 63<sup>rd</sup> Street South and Deer Creek Parkway South.

Bounded on the east at 45<sup>th</sup> Street South, the east section line of Section 4, Township 139 North, Range 49 West and the east boundary of Drain 27.

All of the foregoing is located in the City of Fargo, Cass County, North Dakota and its Extra-Territorial Area.

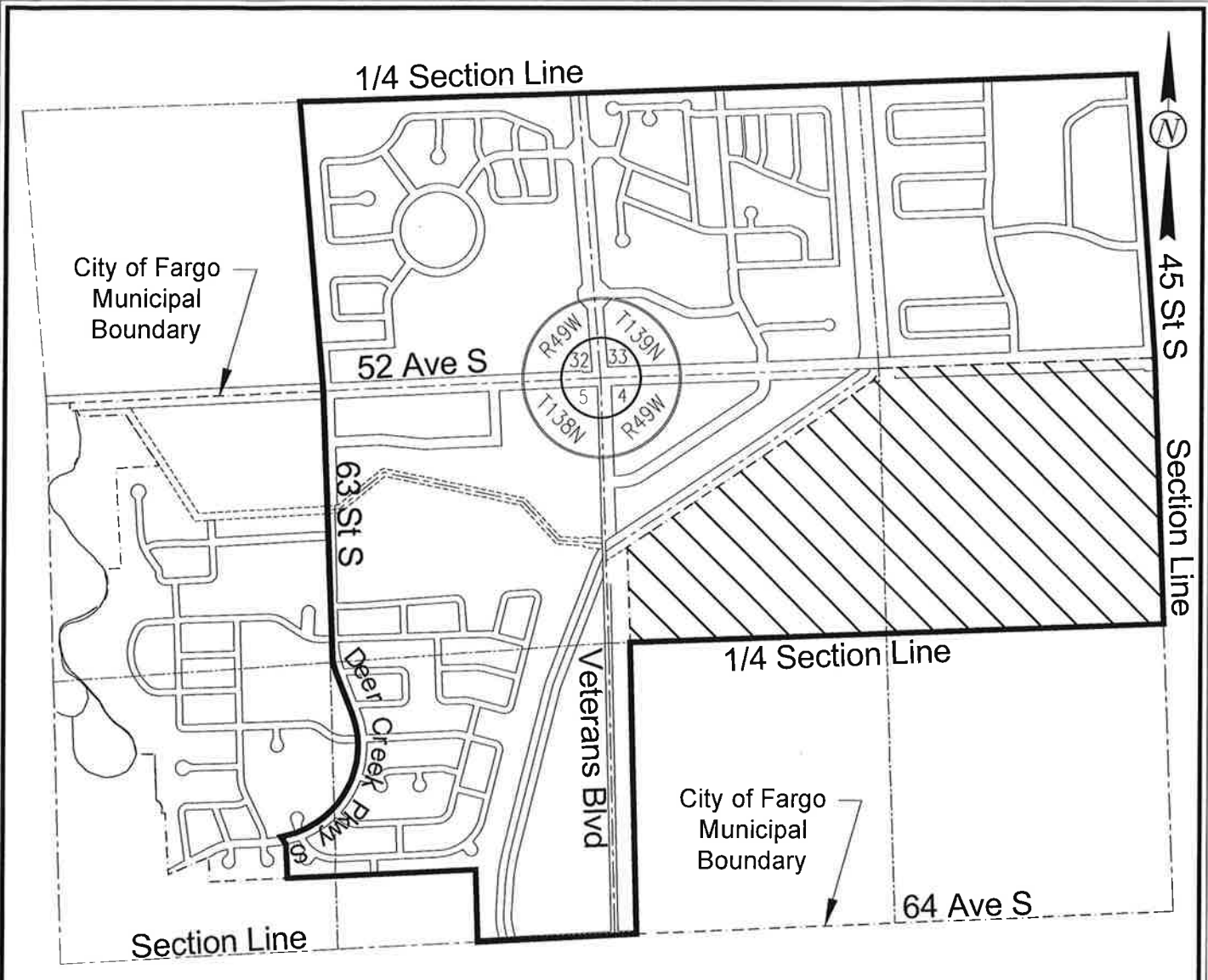

CITY OF FARGO  
ENGINEERING DEPARTMENT

LOCATION, ASSESSMENT AREA & FUTURE  
BENEFITING AREA OUTSIDE CITY OF FARGO  
CITY LIMITS

GRADING, SALVAGED BASE, PC CONCRETE PAVEMENT, HOT MIX ASPHALT,  
STORM DRAIN, STREET LIGHTING, TRAFFIC SIGNALS, PAVEMENT MARKING,  
SHARED USE PATH, SIDEWALK, BRIDGE, WATER MAIN & INCIDENTALS

IMPROVEMENT DISTRICT NO. BN-19-A



FUTURE BENEFITING AREA OUTSIDE CITY LIMITS



ENGINEERING DEPARTMENT  
225 4<sup>th</sup> Street North  
Fargo, North Dakota 58102  
Phone: (701) 241-1545  
Fax: (701) 241-8101  
E-Mail: Feng@FargoND.gov

51-1

October 3, 2018

Honorable Board of  
City Commissioners  
City of Fargo  
Fargo, ND

Re: Concur with Low Bid Award and Contract Award  
Flood Mitigation, Street Reconstruction & Incidentals  
Improvement District No. FM-14-8  
Diversion Authority Project No. WP 42E

Dear Commissioners:

Bids were opened by the Diversion Authority for WP 42E on September 21, 2018 for the City of Fargo Improvement District No. FM-14-8, which consists of 2<sup>nd</sup> Street S Floodwall Construction, Storm Sewer Lift Station #1 Reconstruction, 2<sup>nd</sup> Street South Reconstruction and Incidentals.

The low bidder for WP 42E was Industrial Builders, Inc. with a total low bid of \$8,769,445.23. There was a total of two bids received. A bid summary is attached with this letter. The Engineer's Estimate for this project was \$9,709,061.40.

No protests were received for this district. The special assessment escrow is not required.

This office recommends that the City of Fargo concurs with the Division Authority's low bid award and the contract award to Industrial Builders, Inc. for WP 42E as the lowest and best bid, and authorize the Diversion Authority to enter into a contract with Industrial Builders, Inc.

Sincerely,  
  
Nathan Boerboom  
Division Engineer

NAB/jmg  
Attachment

C: Kristi Olson  
Steve Sprague

Street Lighting  
Sidewalks

Design & Construction  
Traffic Engineering

Truck Regulatory  
Flood Plain Mgmt.

Mapping & GIS  
Utility Locations

Bid Tabulation  
 2nd Street/Downtown Area - In-Town Lanes  
 Phase WPA2E  
 Bid Opening - September 21, 2018

ITEM	DESCRIPTION	UNIT	TOTAL ESTIMATED QUANTITY	CITY OF FARGO ESTIMATED QUANTITY	DIVERSION AUTHORITY ESTIMATED QUANTITY	Engineer's Estimate			Industrial Builders, Inc.			John T. Ahoist Construction			
						CITY OF FARGO BID UNIT PRICE	DIVERSION AUTHORITY BID PRICE	TOTAL LINE ITEM BID PRICE	CITY OF FARGO BID PRICE	DIVERSION AUTHORITY BID PRICE	TOTAL LINE ITEM BID PRICE	CITY OF FARGO BID PRICE	DIVERSION AUTHORITY BID PRICE	TOTAL LINE ITEM BID PRICE	
<b>Water Main</b>															
1.	Remove Hydrant	EA	2	0	2	1,000.00	2,000.00	2,000.00	1,050.00	2,050.00	2,050.00	3,095.00	6,144.00	6,144.00	
2.	8" Watermain Pipe CS90 DR 18	LF	46	0	46	110.00	5,060.00	5,060.00	85.00	3,910.00	3,910.00	497.00	22,862.00	22,862.00	
3.	8" Gate Valve 10" Dia	EA	1	0	1	4,000.00	4,000.00	4,000.00	5,195.00	3,195.00	3,195.00	3,057.00	3,082.00	3,082.00	
4.	Remove Watermain Pipe All Sizes All Types	LF	216	0	216	25.00	5,400.00	5,400.00	41.00	8,956.00	8,956.00	129.00	27,864.00	27,864.00	
5.	8" Watermain Fittings Ductile Iron	LBS	32	0	32	7.00	224.00	224.00	18.00	576.00	576.00	25.00	800.00	800.00	
6.	8" 1/2" Copper Irrigation Service	LF	14	0	14	25.00	350.00	350.00	90.00	1,260.00	1,260.00	214.00	2,996.00	2,996.00	
<b>Storm Sewer</b>															
7.	8" Storm Manhole 4' Dia Reinf Conc	EA	2	0	2	5,500.00	11,000.00	11,000.00	5,240.00	10,480.00	10,480.00	9,890.00	19,780.00	19,780.00	
8.	8" Storm Manhole 8' Dia Reinf Conc	EA	1	0	1	20,000.00	20,000.00	20,000.00	28,400.00	28,400.00	28,400.00	16,254.00	16,254.00	16,254.00	
9.	8" Storm Manhole 57-7 (CIP)	EA	1	0	1	600,000.00	600,000.00	600,000.00	750,000.00	750,000.00	750,000.00	1,105,641.40	1,105,641.40	1,105,641.40	
10.	8" Lift Station	LS	1	0	1	2,500,000.00	2,500,000.00	2,500,000.00	1,771,000.00	1,771,000.00	1,771,000.00	2,903,734.52	2,903,734.52	2,903,734.52	
11.	Discharge Pipe	LS	1	0	1	200,000.00	200,000.00	200,000.00	133,400.00	133,400.00	133,400.00	232,811.00	232,811.00	232,811.00	
12.	8" (Concrete) Structure	LF	1	0	1	750,000.00	750,000.00	750,000.00	800,000.00	800,000.00	800,000.00	1,438,042.88	1,438,042.88	1,438,042.88	
13.	8" Inlet - Single Box (SB) Reinf Conc	EA	2	0	2	4,000.00	8,000.00	8,000.00	4,500.00	9,000.00	9,000.00	5,800.00	5,800.00	5,800.00	
14.	Remove Existing Pump Station and Transformers	EA	1	0	1	100,000.00	100,000.00	100,000.00	92,000.00	92,000.00	92,000.00	68,260.00	68,260.00	68,260.00	
15.	Remove Storm Inlet	EA	3	0	3	1,000.00	3,000.00	3,000.00	1,800.00	1,800.00	1,800.00	2,480.00	2,480.00	2,480.00	
16.	Remove Storm Manhole	EA	3	0	3	2,700.00	8,100.00	8,100.00	3,000.00	9,000.00	9,000.00	5,725.00	17,175.00	17,175.00	
17.	Remove Storm Pipe All Sizes All Types	LF	396	46	350	30.00	10,500.00	11,880.00	45.50	2,093.00	15,915.00	107.00	4,922.00	37,450.00	
18.	Plug Storm Pipe 14" thru 24" Dia	EA	1	0	1	2,000.00	2,000.00	2,000.00	2,485.00	2,485.00	2,485.00	3,860.00	3,860.00	3,860.00	
19.	Plug Storm Pipe 42" thru 54" Dia	EA	2	0	2	5,000.00	10,000.00	10,000.00	8,187.00	6,174.00	6,174.00	4,784.00	9,568.00	9,568.00	
20.	8" Storm Pipe 18" Dia Reinf Conc	LF	147	0	147	95.00	13,965.00	13,965.00	146.00	21,462.00	21,462.00	235.00	34,545.00	34,545.00	
21.	8" Storm Pipe w/ 6B 12" Dia Reinf Conc	LF	8	0	8	150.00	1,200.00	1,200.00	183.00	1,464.00	1,464.00	596.00	4,760.00	4,760.00	
22.	8" Storm Pipe 60" Dia Reinf Conc	LF	195	0	195	550.00	107,250.00	107,250.00	793.00	154,695.00	154,695.00	527.00	102,765.00	102,765.00	
23.	8" Storm Pipe 72" Dia Reinf Conc	LF	54	0	54	1,000.00	54,000.00	54,000.00	1,290.00	69,660.00	69,660.00	1,105.00	59,670.00	59,670.00	
24.	Item & Repl Castings - Inlet	EA	5	0	5	500.00	2,500.00	2,500.00	8,790.00	8,790.00	8,790.00	2,990.00	2,990.00	2,990.00	
25.	8" 1st Ave N Bridge Drain Outlet	LS	1	0	1	10,000.00	10,000.00	10,000.00	11,880.00	11,880.00	11,880.00	29,000.00	29,000.00	29,000.00	
<b>Paving</b>															
26.	Remove Pavement All Thicknesses All Types	SY	6,712	3,162	3,550	20.00	63,240.00	74,240.00	20.25	64,035.00	11,137.50	20.00	63,340.00	11,000.00	74,340.00
27.	Remove Sidewalk All Thicknesses All Types	SY	1,440	102	1,338	10.00	1,020.00	14,400.00	31.00	3,162.00	41,478.00	10.50	1,071.00	14,049.00	
28.	Remove Width All Thicknesses All Types	SY	388	348	398	15.00	2,145.00	5,970.00	20.20	2,888.60	9,939.00	25.00	3,575.00	4,875.00	
29.	Remove Curb & Gutter	LF	2,805	1,801	504	10.00	18,010.00	23,050.00	6.30	11,346.30	31,792.00	10.00	18,010.00	5,040.00	
30.	Remove Construction Entrance	EA	2	1	1	3,000.00	3,000.00	6,000.00	3,100.00	3,100.00	3,100.00	1,000.00	1,000.00	2,000.00	



Bid Tabulation  
 2nd Street/DownTown Area - In-Town Leases  
 Phase W19A2E  
 Bid Opening - September 21, 2018

ITEM	DESCRIPTION	UNIT	TOTAL ESTIMATED QUANTITY	CITY OF FARGO ESTIMATED QUANTITY	DIVISION AUTHORITY ESTIMATED QUANTITY	Engineer's Estimate			Industrial Building, Inc.			John T. Jones Construction			TOTAL LINE ITEM BID PRICE				
						CITY OF FARGO BID PRICE	DIVISION AUTHORITY BID PRICE	TOTAL LINE ITEM BID PRICE	CITY OF FARGO BID PRICE	DIVISION AUTHORITY BID PRICE	TOTAL LINE ITEM BID PRICE	CITY OF FARGO BID PRICE	DIVISION AUTHORITY BID PRICE	TOTAL LINE ITEM BID PRICE					
31.	Subgrade Preparation	SY	3,363	2,812	549	2,50	2,50	1,000.00	1,372.50	8,402.50	3.90	10,958.80	2,143.10	11,107.80	11,107.80	4.00	11,248.00	2,195.00	13,443.00
32.	F81 Woven Geotextile	SY	6,173	2,812	3,361	2,50	2,50	1,000.00	6,492.50	15,612.50	2.85	8,074.20	9,576.85	17,595.85	5.00	8,436.00	10,085.00	18,519.00	
33.	F81 Class 5 8'x12' Thick	SY	1,509	2,812	694	12.00	12.00	33,744.00	8,328.00	42,072.00	14.30	40,211.80	9,274.30	50,115.80	15.00	50,615.00	12,497.00	63,108.00	
34.	F81 Edge Drain 4" Dia PVC	LF	1,596	1,160	436	20.00	20.00	27,200.00	4,720.00	31,920.00	29.60	40,256.00	6,985.60	47,241.60	8.00	10,886.00	1,888.00	12,768.00	
35.	F81 Curb & Gutter Standard (Type II)	LF	1,996	1,360	636	25.00	25.00	34,000.00	5,900.00	39,900.00	22.60	90,736.00	5,338.60	96,069.60	22.25	30,260.00	5,251.00	35,511.00	
36.	F81 Pavement 9" Thick Dowelled Conc	SY	2,595	1,360	1,235	90.00	90.00	122,400.00	110,250.00	232,650.00	72.80	99,078.00	89,180.00	188,188.00	70.00	95,200.00	85,750.00	180,950.00	
37.	F81 Sidewalk 4" Thick Reinf Conc	SY	340	88	252	75.00	75.00	6,600.00	18,900.00	25,500.00	51.20	4,505.60	12,902.40	17,408.00	4.88	429.44	1,229.76	1,659.20	
38.	F81 Driveway 7" Thick Reinf Conc	SY	1,048	17	1,031	95.00	95.00	1,615.00	97,945.00	99,560.00	65.40	1,111.80	67,427.40	68,539.20	61.00	1,097.00	62,891.00	63,928.00	
39.	F81 Grooved Plastic Film 4" Wide	LF	228	54	174	7.00	7.00	378.00	1,218.00	1,596.00	6.40	345.60	1,111.60	1,459.20	6.10	329.40	1,051.40	1,380.80	
40.	F81 Grooved Concrete Film 7" Wide	LF	1,670	1,195	475	10.00	10.00	11,950.00	4,750.00	16,700.00	12.00	14,340.00	5,700.00	20,040.00	11.40	13,623.00	5,415.00	19,038.00	
41.	Wet Lay 1/2" x 8' Wide Traffic Concrete Type 2	LS	15	0	15	7.00	7.00	105.00	98.00	203.00	97.00	1,437.00	798.00	2,235.00	55.00	770.00	770.00	1,465.00	
42.	F81 Sign Assembly	EA	0.5	0.5	0	120.00	120.00	60.00	60.00	72.00	95,700.00	95,700.00	22,089.00	7,611.00	29,899.00	42,840.00	13,850.80	5,969.20	21,420.00
43.	F81 Engineering Grade SF	SY	15	0	15	25.00	25.00	375.00	375.00	750.00	180.00	1,800.00	960.00	2,760.00	120.00	1,200.00	850.00	340.00	1,190.00
44.	F81 High Intensity Prismatic SF	SY	9	0	9	30.00	30.00	270.00	270.00	540.00	18.00	162.00	176.40	338.40	16.50	144.00	161.70	305.70	
45.	F81 Flexible Delineator	EA	0	0	0	75.00	75.00	0	0	0	84.00	320.00	320.00	320.00	61.20	306.00	306.00	306.00	
<b>Miscellaneous</b>																			
46.	Mechanization	LS	1	0	1	500.00	500.00	500.00	500.00	500.00	500.00	500.00	500.00	500.00	452.330.00	452.330.00	407.097.00	462.330.00	
47.	Remove Existing Stairs	LS	1	0	1	20.00	20.00	20.00	20.00	20.00	15.150.00	15.150.00	15.150.00	15.150.00	7.520.00	7.520.00	7.520.00	7,520.00	
50.	Remove Existing Retaining Wall	LS	1	0	1	75.00	75.00	75.00	75.00	75.00	38,150.00	38,150.00	38,150.00	38,150.00	42,800.00	42,800.00	42,800.00	43,800.00	
51.	Remove Closure Structure	LS	1	0	1	20.00	20.00	20.00	20.00	20.00	20,000.00	20,000.00	20,000.00	20,000.00	3,680.00	3,680.00	3,680.00	3,680.00	
52.	Remove Light	EA	30	0	30	450.00	450.00	13,500.00	13,500.00	13,500.00	262.00	7,860.00	7,860.00	7,860.00	390.00	10,500.00	10,500.00	10,500.00	
53.	Structural Conc	CY	135.5	0	135.5	1,600.00	1,600.00	216,800.00	216,800.00	216,800.00	1,600.00	216,800.00	216,800.00	216,800.00	705.90	95,824.25	95,824.25	95,824.25	
54.	F81 Lighting	LF	0.95	0	0.95	138,000.00	138,000.00	131,100.00	131,100.00	131,100.00	137,368.42	130,500.00	130,500.00	130,500.00	137,368.42	130,500.00	130,500.00	130,500.00	
55.	F81 Decorative Fence	LF	458	0	458	400.00	400.00	183,200.00	183,200.00	183,200.00	248.00	113,584.00	113,584.00	113,584.00	237.05	108,568.90	108,568.90	108,568.90	
56.	F81 Billboards	EA	1.9	0	1.9	1,000.00	1,000.00	1,900.00	1,900.00	1,900.00	1,000.00	1,900.00	1,900.00	1,900.00	790.00	9,750.00	9,750.00	9,750.00	
57.	Temp Fence - Safety	LF	3,996	1,599	2,397	10.00	10.00	15,990.00	15,990.00	15,990.00	7.00	10,745.00	13,027.00	23,772.00	6.40	9,874.00	11,910.40	21,784.40	
58.	Temp Pulpment	LS	1	0	1	10,000.00	10,000.00	10,000.00	10,000.00	10,000.00	15,000.00	15,000.00	15,000.00	14,200.00	7,800.00	7,800.00	7,800.00		
59.	Clear & Grub	LS	313	0	313	10,000.00	10,000.00	3,130,000.00	3,130,000.00	3,130,000.00	675.00	22,275.00	22,275.00	22,275.00	221.00	7,800.00	7,800.00	7,800.00	
60.	Remove Tree	EA	1	0	1	500.00	500.00	500.00	500.00	500.00	2.40	3,337.50	3,337.50	3,337.50	2.50	3,337.50	3,337.50	3,337.50	
61.	Split Fence - Standard	LF	1,335	0	1,335	2.50	2.50	3,337.50	3,337.50	3,337.50	22.00	29,220.00	29,220.00	29,220.00	21.00	8,610.00	8,610.00	8,610.00	
62.	Retaining Wall - 10" to 15"	LF	456	0	456	250.00	250.00	114,000.00	114,000.00	114,000.00	142.00	64,840.00	64,840.00	64,840.00	135.00	270.00	270.00	270.00	
63.	Soil Protection - New Inlet	EA	1	0	1	200.00	200.00	200.00	200.00	200.00	142.00	568.00	568.00	568.00	135.00	560.00	560.00	560.00	
65.	Inlet Protection - Existing Inlet	EA	1	0	1	200.00	200.00	200.00	200.00	200.00	142.00	568.00	568.00	568.00	135.00	560.00	560.00	560.00	
66.	Lift Station and Gwells #13	LS	1	0	1	900,000.00	900,000.00	900,000.00	900,000.00	900,000.00	220,000.00	220,000.00	220,000.00	220,000.00	140,480.00	140,480.00	140,480.00	140,480.00	
<b>Landscaping</b>																			
67.	Paver Type A	SF	1,419	0	1,419	26.00	26.00	36,894.00	36,894.00	36,894.00	16.15	22,916.85	22,916.85	22,916.85	16.87	23,938.53	23,938.53	23,938.53	
68.	Paver Type B	SF	3,942	0	3,942	26.00	26.00	102,492.00	102,492.00	102,492.00	16.15	63,663.30	63,663.30	63,663.30	16.87	66,501.54	66,501.54	66,501.54	
69.	Paver Type C	SF	935	0	935	26.00	26.00	24,310.00	24,310.00	24,310.00	16.15	15,100.25	15,100.25	15,100.25	16.87	15,773.45	15,773.45	15,773.45	
70.	Sloped Concrete Planter-Curb	LF	636	0	636	75.00	75.00	47,700.00	47,700.00	47,700.00	50.50	31,900.00	31,900.00	31,900.00	44.00	27,544.00	27,544.00	27,544.00	

Bid Tabulation  
 2nd Street/Downtown Area - In-Town Levees  
 Phase W192Z  
 Bid Opening - September 21, 2018

ITEM	DESCRIPTION	UNIT	TOTAL ESTIMATED QUANTITY	Engineer's Estimate			Industrial Builders, Inc.			John T. Jones Construction			TOTAL LINE ITEM BID PRICE
				CITY OF FARGO ESTIMATED QUANTITY	DIVERSION AUTHORITY ESTIMATED QUANTITY	CITY OF FARGO BID PRICE	CITY OF FARGO BID PRICE	DIVERSION AUTHORITY BID PRICE	CITY OF FARGO BID PRICE	DIVERSION AUTHORITY BID PRICE	CITY OF FARGO BID PRICE	DIVERSION AUTHORITY BID PRICE	
71.	Deciduous Tree 1.5" Cal. B&B	EA	65		600.00	\$	39,000.00	\$	39,000.00	\$	36,910.00	\$	25,675.00
72.	Deciduous Shrub No.2 Cont.	EA	159		50.00	\$	7,950.00	\$	7,950.00	\$	13,175.00	\$	12,555.00
73.	Perennial No.1 Cont.	EA	1,117		30.00	\$	33,510.00	\$	33,510.00	\$	62,181.00	\$	59,301.00
74.	Furnish and Install Topsoil - Import Special (18" depth)	CY	631		60.00	\$	50,400.00	\$	50,400.00	\$	86,340.00	\$	79,998.18
75.	Subsoiling	SY	100		0.25	\$	25.00	\$	25.00	\$	3,000.00	\$	3,000.00
76.	Landscaping Edger	LF	83		9.00	\$	567.00	\$	567.00	\$	562.75	\$	553.77
77.	Salvage and Reinstall 6 FT Bench	EA	8		1,000.00	\$	8,000.00	\$	8,000.00	\$	4,000.00	\$	1,256.00
78.	Receptacle	EA	6		800.00	\$	4,800.00	\$	4,800.00	\$	2,700.00	\$	450.00
<b>Flood Mitigation</b>													
79.	F&I Sheet Piling - Steel	SF	235		40.00	\$	14,100.00	\$	14,100.00	\$	14,100.00	\$	26,000.40
80.	Teppal - Strip	CY	1,500		5.00	\$	7,500.00	\$	7,500.00	\$	7,650.00	\$	5,880.00
81.	Teppal - Spread	CY	1,500		4.00	\$	6,000.00	\$	6,000.00	\$	4,785.00	\$	5,880.00
82.	Embankment	CY	2,495		18.00	\$	44,910.00	\$	44,910.00	\$	16.15	\$	39.80
83.	Embankment Import	CY	500		30.00	\$	15,000.00	\$	15,000.00	\$	25.75	\$	12,875.00
84.	Excavation	CY	500		10.00	\$	5,000.00	\$	5,000.00	\$	11.25	\$	5,625.00
85.	Excavation	CY	1,795		2.50	\$	4,487.50	\$	4,487.50	\$	10.10	\$	18,129.50
86.	Excavation/Hill	CY	1,235		12.00	\$	14,820.00	\$	14,820.00	\$	14.00	\$	17,290.00
87.	Mixing Type 1 - Hydrate	SW	17,307		0.45	\$	7,788.15	\$	7,788.15	\$	0.40	\$	6,306.60
88.	Mixing Type B	SW	17,307		0.35	\$	6,057.45	\$	6,057.45	\$	0.37	\$	6,409.59
89.	Overseeding	SY	17,307		0.20	\$	3,461.40	\$	3,461.40	\$	0.21	\$	3,634.47
90.	Weed Control Type B	SY	17,307		0.10	\$	1,730.70	\$	1,730.70	\$	0.07	\$	1,211.49
91.	Renovable Closure	SF	1,023		130.00	\$	132,990.00	\$	132,990.00	\$	134.00	\$	136,852.00
92.	F&I Floodwall Reinl Bars - Steel	LB	110,573		1.75	\$	193,502.75	\$	193,502.75	\$	2.00	\$	221,146.00
93.	F&I Floodwall Reinl Bars - Epoxy Coated Steel	LB	54,748		2.00	\$	109,496.00	\$	109,496.00	\$	2.00	\$	109,496.00
94.	F&I Floodwall - Structural Conc.	CY	306.1		1,100.00	\$	966,710.00	\$	966,710.00	\$	1,315.00	\$	1,200,562.50
95.	F&I Floodwall Walling	LF	200		350.00	\$	70,000.00	\$	70,000.00	\$	347.00	\$	69,400.00
<b>Project Area Within the Main Avenue Overlay</b>													
96.	F&I Waterman Pipe C500 DR 18 10' Dia PVC Overlay	LF	14		110.00	\$	1,540.00	\$	1,540.00	\$	81.00	\$	1,134.00
97.	Remove Watermain Pipe All Sizes All Types Overlay	LF	185		25.00	\$	4,625.00	\$	4,625.00	\$	38.00	\$	7,030.00
98.	F&I 1" Copper Irrigation Service Overlay	LF	82		25.00	\$	2,050.00	\$	2,050.00	\$	35.00	\$	2,870.00
99.	Connect Water Service Overlay	EA	1		1,500.00	\$	1,500.00	\$	1,500.00	\$	1,700.00	\$	1,700.00
<b>Storm Sewer - Main Avenue Overlay</b>													
100.	F&I Storm Manhole Type E Reinl 60" Overlay	EA	1		50,000.00	\$	50,000.00	\$	50,000.00	\$	40,000.00	\$	40,000.00
101.	F&I Storm Manhole ST-7 Shoring	LS	1		300,000.00	\$	300,000.00	\$	300,000.00	\$	100.00	\$	100.00
102.	F&I Inlet - Manhole (MH) 4' Dia Reinl Conc Overlay	EA	1		6,000.00	\$	6,000.00	\$	6,000.00	\$	7,780.00	\$	7,780.00
103.	F&I Inlet - Manhole (MH) 6' Dia Reinl Conc Overlay	EA	1		20,000.00	\$	20,000.00	\$	20,000.00	\$	29,000.00	\$	29,000.00



Bid Tabulation  
 2nd Street/Downtown Area - In-Town Lanes  
 Phase W942E  
 Bid Opening - September 21, 2018

ITEM	DESCRIPTION	UNIT	TOTAL ESTIMATED QUANTITY	CITY OF FARGO ESTIMATED QUANTITY	DIVERSION AUTHORITY ESTIMATED QUANTITY	Engineer's Estimate			Industrial Builders, Inc.			John T. Jansen Construction		
						CITY OF FARGO BID UNIT PRICE	DIVERSION AUTHORITY BID PRICE	TOTAL LINE ITEM BID PRICE	CITY OF FARGO BID UNIT PRICE	DIVERSION AUTHORITY BID PRICE	TOTAL LINE ITEM BID PRICE	CITY OF FARGO BID UNIT PRICE	DIVERSION AUTHORITY BID PRICE	TOTAL LINE ITEM BID PRICE
104.	F&I Inlet - Single Box (SBI) Reinf Conc.Overlap	EA	1	0	1	\$ 4,000.00	\$ 4,000.00	\$ 4,000.00	\$ 4,300.00	\$ 2,000.00	\$ 4,300.00	\$ 2,000.00	\$ 2,000.00	\$ 2,000.00
105.	Remove Storm Inlet Overlap	EA	5	0	5	\$ 500.00	\$ 2,500.00	\$ 2,500.00	\$ 900.00	\$ 1,000.00	\$ 4,900.00	\$ 1,000.00	\$ 5,000.00	\$ 5,000.00
106.	Remove Storm Manhole Overlap	EA	2	0	2	\$ 2,700.00	\$ 5,400.00	\$ 5,400.00	\$ 3,000.00	\$ 3,000.00	\$ 6,000.00	\$ 2,512.50	\$ 5,025.00	\$ 5,025.00
107.	Remove Storm Pipe All Stess All Types Overlap	LF	425	0	425	\$ 30.00	\$ 12,750.00	\$ 12,750.00	\$ 28.00	\$ 89.00	\$ 11,900.00	\$ 89.00	\$ 37,825.00	\$ 37,825.00
108.	F&I Storm Pipe 18" Dia Reinf Conc.Overlap	LF	6	0	6	\$ 95.00	\$ 570.00	\$ 570.00	\$ 140.00	\$ 238.00	\$ 840.00	\$ 238.00	\$ 1,998.00	\$ 1,998.00
109.	F&I Storm Pipe 12" Dia Reinf Conc.Overlap	LF	22	0	22	\$ 70.00	\$ 1,540.00	\$ 1,540.00	\$ 72.00	\$ 220.00	\$ 1,584.00	\$ 220.00	\$ 4,840.00	\$ 4,840.00
110.	F&I Storm Pipe w/63 12" Dia Reinf Conc.Overlap	LF	5	0	5	\$ 150.00	\$ 750.00	\$ 750.00	\$ 174.00	\$ 360.00	\$ 870.00	\$ 360.00	\$ 1,800.00	\$ 1,800.00
111.	F&I Storm Pipe 24" Dia Reinf Conc.Overlap	LF	70	0	70	\$ 150.00	\$ 10,500.00	\$ 10,500.00	\$ 145.00	\$ 300.00	\$ 10,150.00	\$ 300.00	\$ 21,000.00	\$ 21,000.00
112.	F&I Storm Pipe w/68 24" Dia Reinf Conc.Overlap	LF	115	0	115	\$ 250.00	\$ 28,750.00	\$ 28,750.00	\$ 237.00	\$ 450.00	\$ 27,255.00	\$ 450.00	\$ 46,000.00	\$ 46,000.00
113.	F&I Storm Pipe 60" Dia Reinf Conc.Overlap	LF	4	0	4	\$ 550.00	\$ 2,200.00	\$ 2,200.00	\$ 700.00	\$ 568.00	\$ 2,800.00	\$ 568.00	\$ 2,252.00	\$ 2,252.00
114.	F&I Storm Pipe w/68 60" Dia Reinf Conc.Overlap	LF	24	0	24	\$ 1,400.00	\$ 33,600.00	\$ 33,600.00	\$ 1,500.00	\$ 600.00	\$ 36,000.00	\$ 600.00	\$ 14,400.00	\$ 14,400.00
<b>Perfor - Main Avenue Overlap</b>														
115.	Remove Pavement All Thicknesses All Types Overlap	SY	1,742	0	1,742	\$ 30.00	\$ 52,260.00	\$ 52,260.00	\$ 19.00	\$ 33,096.00	\$ 33,096.00	\$ 20.00	\$ 34,840.00	\$ 34,840.00
116.	Remove Sidewalk All Thicknesses All Types Overlap	SY	959	0	959	\$ 10.00	\$ 9,590.00	\$ 9,590.00	\$ 29.00	\$ 27,811.00	\$ 27,811.00	\$ 10.50	\$ 10,069.50	\$ 10,069.50
117.	Remove Median All Thicknesses All Types Overlap	SY	362	0	362	\$ 15.00	\$ 5,430.00	\$ 5,430.00	\$ 19.00	\$ 6,876.00	\$ 6,876.00	\$ 25.00	\$ 9,050.00	\$ 9,050.00
118.	Remove Curb & Gutter Overlap	LF	1,265	0	1,265	\$ 10.00	\$ 12,650.00	\$ 12,650.00	\$ 5.00	\$ 6,325.00	\$ 6,325.00	\$ 10.00	\$ 12,650.00	\$ 12,650.00
119.	Temp Construction Entrance Overlap	EA	1	0	1	\$ 3,000.00	\$ 3,000.00	\$ 3,000.00	\$ 2,100.00	\$ 1,000.00	\$ 2,100.00	\$ 1,000.00	\$ 1,000.00	\$ 1,000.00
120.	Subgrade Preparation Overlap	SY	1,711	0	1,711	\$ 2.50	\$ 4,277.50	\$ 4,277.50	\$ 3.50	\$ 5,988.50	\$ 5,988.50	\$ 4.00	\$ 6,844.00	\$ 6,844.00
121.	F&I Woven Geotextile Overlap	SY	1,711	0	1,711	\$ 2.50	\$ 4,277.50	\$ 4,277.50	\$ 2.70	\$ 4,619.70	\$ 4,619.70	\$ 3.00	\$ 5,139.00	\$ 5,139.00
122.	F&I Edge Drain 4" Dia PVC Overlap	LF	1,711	0	1,711	\$ 10.00	\$ 17,110.00	\$ 17,110.00	\$ 11.25	\$ 19,248.75	\$ 19,248.75	\$ 4.00	\$ 6,844.00	\$ 6,844.00
123.	F&I Curb & Gutter Standard (Type I) Overlap	LF	657	0	657	\$ 20.00	\$ 13,140.00	\$ 13,140.00	\$ 28.20	\$ 18,527.40	\$ 18,527.40	\$ 8.00	\$ 5,256.00	\$ 5,256.00
124.	F&I Curb & Gutter Standard (Type II) Overlap	LF	15	0	15	\$ 20.00	\$ 300.00	\$ 300.00	\$ 30.00	\$ 450.00	\$ 450.00	\$ 61.00	\$ 915.00	\$ 915.00
125.	F&I Median Nose - Conc.Overlap	LF	1,004	0	1,004	\$ 25.00	\$ 25,100.00	\$ 25,100.00	\$ 80.00	\$ 30,120.00	\$ 30,120.00	\$ 22.25	\$ 22,339.00	\$ 22,339.00
126.	F&I Sidewalk 4" Thick Reinf Conc.Overlap	SY	27	0	27	\$ 110.00	\$ 2,970.00	\$ 2,970.00	\$ 86.00	\$ 2,592.00	\$ 2,592.00	\$ 82.00	\$ 2,214.00	\$ 2,214.00
127.	F&I Impressioned 4" Thick Reinf Conc.Overlap	SY	1,477	0	1,477	\$ 75.00	\$ 110,775.00	\$ 110,775.00	\$ 78.75	\$ 116,313.75	\$ 116,313.75	\$ 49.00	\$ 72,375.00	\$ 72,375.00
128.	F&I Impressioned 4" Thick Reinf Conc.Overlap	SY	134	0	134	\$ 110.00	\$ 14,740.00	\$ 14,740.00	\$ 105.00	\$ 14,070.00	\$ 14,070.00	\$ 103.00	\$ 13,802.00	\$ 13,802.00
129.	F&I Aggregate for Asphalt Pavement F&I 43 Overlap	SF	120	0	120	\$ 55.00	\$ 6,600.00	\$ 6,600.00	\$ 43.50	\$ 5,220.00	\$ 5,220.00	\$ 52.00	\$ 6,252.00	\$ 6,252.00
130.	F&I Aggregate for Asphalt Pavement F&I 43 Overlap	10th	499	0	499	\$ 75.00	\$ 37,425.00	\$ 37,425.00	\$ 69.75	\$ 34,809.25	\$ 34,809.25	\$ 57.00	\$ 28,443.00	\$ 28,443.00



Bid Tabulation  
2nd Street/Downtown Area - In-Town Levees  
Phase WPA2E  
Bid Opening - September 21, 2018

ITEM	DESCRIPTION	UNIT	TOTAL ESTIMATED QUANTITY	CITY OF FARGO ESTIMATED QUANTITY	DIVERSION AUTHORITY ESTIMATED QUANTITY	Engineer's Estimate			Industrial Builders, Inc.			John T. Jones Construction			
						CITY OF FARGO BID PRICE	DIVERSION AUTHORITY BID PRICE	TOTAL LINE ITEM BID PRICE	CITY OF FARGO BID PRICE	DIVERSION AUTHORITY BID PRICE	TOTAL LINE ITEM BID PRICE	CITY OF FARGO BID PRICE	DIVERSION AUTHORITY BID PRICE	TOTAL LINE ITEM BID PRICE	
131.	F&I Asphalt Cement PG 58-28 Overlap	Gal	7,178	0	7,178	\$ 21,534.00	\$	\$ 21,534.00	\$ 2.20	\$	\$ 15,791.60	\$ 3.00	\$	\$ 21,534.00	
132.	F&I Grooved Plastic Film 4" Wide Overlap	LF	11	0	11	\$ 77.00	\$	\$ 77.00	\$ 9.00	\$	\$ 99.00	\$ 9.50	\$	\$ 104.50	
133.	F&I Grooved Concrete Film 7" Wide Overlap	LF	43	0	43	\$ 430.00	\$	\$ 430.00	\$ 11.00	\$	\$ 473.00	\$ 11.40	\$	\$ 490.20	
134.	Paint Epoxy Liner 8" Wide Overlap	LF	204	0	204	\$ 1,414.00	\$	\$ 1,414.00	\$ 10.00	\$	\$ 2,020.00	\$ 10.30	\$	\$ 2,080.60	
135.	Paint Epoxy Liner 12" Wide Overlap	LF	25	0	25	\$ 500.00	\$	\$ 500.00	\$ 17.00	\$	\$ 425.00	\$ 17.80	\$	\$ 445.00	
136.	Paint Epoxy Liner 24" Wide Overlap	LF	510	0	510	\$ 10,200.00	\$	\$ 10,200.00	\$ 12.00	\$	\$ 6,120.00	\$ 12.40	\$	\$ 6,324.00	
137.	Paint Epoxy Membrane Overlay	SF	32	0	32	\$ 768.00	\$	\$ 768.00	\$ 14.00	\$	\$ 448.00	\$ 14.00	\$	\$ 448.00	
138.	Traffic Control - Type 2 Overlap	LS	0.5	0	0.5	\$ 60,000.00	\$	\$ 60,000.00	\$ 1,560.00	\$	\$ 780.00	\$ 1,560.00	\$	\$ 780.00	
139.	F&I Sign Assembly Overlay	EA	5	0	5	\$ 1,100.00	\$	\$ 1,100.00	\$ 118.00	\$	\$ 990.00	\$ 118.00	\$	\$ 990.00	
140.	F&I Engineering Grade Overlay	SF	4	0	4	\$ 100.00	\$	\$ 100.00	\$ 11.00	\$	\$ 44.00	\$ 11.00	\$	\$ 44.00	
141.	F&I Diamond Grade Cubed Overlay	SF	10.2	0	10.2	\$ 306.00	\$	\$ 306.00	\$ 16.00	\$	\$ 163.20	\$ 16.50	\$	\$ 168.90	
142.	F&I High Intensity Prismatic Overlay	SF	10	0	10	\$ 300.00	\$	\$ 300.00	\$ 15.00	\$	\$ 150.00	\$ 15.00	\$	\$ 150.00	
143.	F&I Flexible Delimitator Overlay	EA	5	0	5	\$ 375.00	\$	\$ 375.00	\$ 61.00	\$	\$ 305.00	\$ 61.20	\$	\$ 306.00	
<b>Miscellaneous - Main Avenue Overlay</b>															
144.	NOT USED					\$	\$	\$			\$			\$	\$
145.	Remove Lights Overlay	EA	4	0	4	\$ 1,800.00	\$	\$ 1,800.00	\$ 282.00	\$	\$ 1,048.00	\$ 350.00	\$	\$ 1,400.00	
146.	Remove and Salvage Traffic Signals Overlay	LS	1	0	1	\$ 5,000.00	\$	\$ 5,000.00	\$ 525.00	\$	\$ 525.00	\$ 2,500.00	\$	\$ 2,500.00	
147.	F&I Lighting Overlay	LS	0.05	0	0.05	\$ 6,900.00	\$	\$ 6,900.00	\$ 138,000.00	\$	\$ 6,750.00	\$ 130,500.00	\$	\$ 6,930.00	
148.	Temp Fence - Safety Overlay	LF	219	0	219	\$ 2,190.00	\$	\$ 2,190.00	\$ 6.00	\$	\$ 1,314.00	\$ 6.40	\$	\$ 1,403.60	
149.	Sediment Control Log 10" to 15" Dia Overlay	LF	563	0	563	\$ 1,829.75	\$	\$ 1,829.75	\$ 2.30	\$	\$ 1,294.90	\$ 2.35	\$	\$ 1,293.05	
150.	Inlet Protection - New Inlet Overlay	EA	3	0	3	\$ 750.00	\$	\$ 750.00	\$ 135.00	\$	\$ 405.00	\$ 135.00	\$	\$ 405.00	
<b>Landscaping - Main Avenue Overlay</b>															
151.	NOT USED					\$	\$	\$			\$			\$	\$
152.	NOT USED					\$	\$	\$			\$			\$	\$
153.	NOT USED					\$	\$	\$			\$			\$	\$
154.	NOT USED					\$	\$	\$			\$			\$	\$
155.	Deciduous Tree 1.5' Cal. 8&8 Overlap	EA	2	0	2	\$ 1,200.00	\$	\$ 1,200.00	\$ 395.00	\$	\$ 790.00	\$ 395.00	\$	\$ 790.00	
156.	Deciduous Shrub No.2 Cont. Overlay	EA	80	0	80	\$ 4,000.00	\$	\$ 4,000.00	\$ 81.00	\$	\$ 6,480.00	\$ 81.00	\$	\$ 6,480.00	
<b>Flood Mitigation - Main Avenue Overlay</b>															
157.	Midnight Type 1 Hydro Overlay	SY	537	0	537	\$ 241.65	\$	\$ 241.65	\$ 0.88	\$	\$ 308.26	\$ 0.88	\$	\$ 308.06	
158.	Freezing Type B Overlay	SY	537	0	537	\$ 187.95	\$	\$ 187.95	\$ 0.35	\$	\$ 187.95	\$ 0.35	\$	\$ 187.95	
159.	Overlapping Overlay	SY	537	0	537	\$ 107.40	\$	\$ 107.40	\$ 0.20	\$	\$ 107.40	\$ 0.20	\$	\$ 107.40	
160.	Freeze Control Type B Overlay	SY	537	0	537	\$ 53.70	\$	\$ 53.70	\$ 0.06	\$	\$ 32.22	\$ 0.06	\$	\$ 32.22	
<b>Traffic Signal - Main Avenue Overlay</b>															

Bid Tabulation  
 2nd Street/Downtown Area - In-Town Levees  
 Phase WPA2E  
 Bid Opening - September 21, 2018

ITEM	DESCRIPTION	UNIT	TOTAL ESTIMATED QUANTITY	CITY OF FARGO ESTIMATED QUANTITY	Engineer's Estimate			Industrial Builders, Inc.			John T. James Construction				
					DIVERSION AUTHORITY ESTIMATED QUANTITY	CITY OF FARGO BID PRICE	DIVERSION AUTHORITY BID PRICE	TOTAL LINE ITEM BID PRICE	CITY OF FARGO BID PRICE	DIVERSION AUTHORITY BID PRICE	TOTAL LINE ITEM BID PRICE	CITY OF FARGO BID PRICE	DIVERSION AUTHORITY BID PRICE	TOTAL LINE ITEM BID PRICE	
161.	Remove Signal Standard Type	EA	3	0	\$ 5,000.00	\$ 15,000.00	\$ 15,000.00	\$ 500.00	\$ 1,500.00	\$ 1,500.00	\$ 1,750.00	\$ 5,250.00	\$ 5,250.00		
162.	IV/Combo Overlap	EA	2	0	\$ 1,500.00	\$ 3,000.00	\$ 3,000.00	\$ 200.00	\$ 400.00	\$ 400.00	\$ 450.00	\$ 900.00	\$ 900.00		
163.	Remove Foundation Type	EA	3	0	\$ 8,000.00	\$ 24,000.00	\$ 24,000.00	\$ 1,000.00	\$ 3,000.00	\$ 3,000.00	\$ 1,800.00	\$ 5,400.00	\$ 5,400.00		
164.	Salvage Traffic Signal Equipment	LS	1	0	\$ 5,500.00	\$ 2,500.00	\$ 2,500.00	\$ 500.00	\$ 500.00	\$ 500.00	\$ 1,500.00	\$ 1,500.00	\$ 1,500.00		
165.	Salvage Signal Cable Overlap	LS	1	0	\$ 2,000.00	\$ 2,000.00	\$ 2,000.00	\$ 100.00	\$ 100.00	\$ 100.00	\$ 1,000.00	\$ 1,000.00	\$ 1,000.00		
166.	841 Conduit 3" Dia. Overlap	LF	14	0	\$ 35.00	\$ 770.00	\$ 770.00	\$ 20.00	\$ 280.00	\$ 280.00	\$ 50.00	\$ 700.00	\$ 700.00		
167.	F61 Signal Cable AWG 14/2 Overlap	LF	2,084	0	\$ 2.50	\$ 5,210.00	\$ 5,210.00	\$ 0.45	\$ 937.80	\$ 937.80	\$ 1.75	\$ 3,647.00	\$ 3,647.00		
168.	F61 Signal Cable AWG 14/3 Overlap	LF	106	0	\$ 3.00	\$ 324.00	\$ 324.00	\$ 0.50	\$ 54.00	\$ 54.00	\$ 4.00	\$ 432.00	\$ 432.00		
169.	F61 Signal Cable AWG 14/5 Overlap	LF	297	0	\$ 4.00	\$ 1,188.00	\$ 1,188.00	\$ 0.75	\$ 222.75	\$ 222.75	\$ 3.00	\$ 891.00	\$ 891.00		
170.	F61 Signal Cable AWG 14/7 Overlap	LF	202	0	\$ 4.50	\$ 909.00	\$ 909.00	\$ 1.40	\$ 282.80	\$ 282.80	\$ 3.50	\$ 707.00	\$ 707.00		
171.	F61 Signal Cable AWG 14/20 Overlap	LF	1,162	0	\$ 10.00	\$ 11,620.00	\$ 11,620.00	\$ 2.30	\$ 2,672.60	\$ 2,672.60	\$ 4.00	\$ 4,648.00	\$ 4,648.00		
172.	F64 Signal Cable AWG 16/#3 Overlap	LF	759	0	\$ 6.00	\$ 4,554.00	\$ 4,554.00	\$ 0.45	\$ 341.55	\$ 341.55	\$ 1.75	\$ 1,328.25	\$ 1,328.25		
173.	F61 Signal Cable CAT 6 Overlap	LF	759	0	\$ 6.00	\$ 4,554.00	\$ 4,554.00	\$ 1.00	\$ 759.00	\$ 759.00	\$ 2.00	\$ 1,518.00	\$ 1,518.00		
174.	Install Interim Signal System Overlap	EA	1	0	\$ 37,500.00	\$ 37,500.00	\$ 37,500.00	\$ 3,000.00	\$ 3,000.00	\$ 3,000.00	\$ 5,600.00	\$ 5,600.00	\$ 5,600.00		
				Engineer's Estimate, Total - All Unit Price Items			\$ 9,709,061.40	Industrial Builders, Inc., Total - All Unit Price Items			\$ 3,769,444.23	John T. James Construction, Total - All Unit Price Items			\$ 3,326,002.47



51-2

ENGINEERING DEPARTMENT  
225 4<sup>th</sup> Street North  
Fargo, North Dakota 58102  
Phone: (701) 241-1545  
Fax: (701) 241-8101  
E-Mail: Feng@FargoND.gov

October 3, 2018

Honorable Board of City  
Commissioners  
City of Fargo  
Fargo, ND

Re: Improvement District No. UN-18-C1

Dear Commissioners:

Bids were opened at 11:30 AM on Wednesday, October 3, 2018, for Sanitary Sewer, Water Main, Storm Sewer & Incidentals, Improvement District No. UN-18-C1, located at Laverne's Addition.

The bids were as follows:

KPH, Inc.	\$1,457,460.25
Dakota Underground Company	\$1,658,610.00
Dirt Dynamics	\$1,703,767.29
Peterson Companies	\$1,849,169.00
RL Larson Excavating, Inc.	\$2,509,356.00

Engineer's Estimate \$1,592,148.50

The special assessment escrow is not required.

This office recommends award of the contract to KPH, Inc. in the amount of \$1,457,460.25 as the lowest and best bid. No protests have been received.

Sincerely,  
  
Thomas Knakmuhs  
Division Engineer

TAK/jmg

**ENGINEER'S STATEMENT OF ESTIMATED COST**  
**IMPROVEMENT DISTRICT # UN-18-C1**  
**Sanitary Sewer, Water Main, Storm Sewer & Incidentals**

Laverne's Addition

WHEREAS, bids have been opened and filed for the above described Improvement District for City of Fargo, North Dakota; and  
WHEREAS, an estimate of the cost of work is required by the engineer for the City of Fargo, North Dakota;

NOW THEREFORE Tom Knakmuhs, do hereby certify as follows:

That I am the Division Engineer for the City of Fargo, North Dakota;

That the following is detailed statement of the estimated cost of the job described as:

Sanitary Sewer, Water Main, Storm Sewer & Incidentals Improvement District # UN-18-C1 of the City of Fargo, North Dakota.

Line Description	Unit	Quantity	Unit Price (\$)	Amount (\$)
<b>Miscellaneous</b>				
1 Topsoil - Strip	LS	1.00	25,000.00	25,000.00
2 Stormwater Management	LS	1.00	700.00	700.00
3 Temp Construction Entrance	EA	2.00	500.00	1,000.00
4 Inlet Protection - Existing Inlet	EA	6.00	160.00	960.00
5 Inlet Protection - New Inlet	EA	23.00	215.00	4,945.00
6 Seeding Type C	SY	19,500.00	0.55	10,725.00
7 Mulching Type 2 - Straw	SY	19,500.00	0.15	2,925.00
8 Silt Fence - Heavy Duty	LF	350.00	4.25	1,487.50
9 Sediment Control Log 10" to 15" Dia	LF	175.00	3.25	568.75
10 Ditch Grading	LF	230.00	6.00	1,380.00
11 Clear & Grub	LS	1.00	3,750.00	3,750.00
			<b>Miscellaneous Total</b>	<b>53,441.25</b>
<b>Sanitary Sewer</b>				
12 F&I 1-1/4" Trench Found Rock 4" thru 12" Dia	LF	1,300.00	1.00	1,300.00
13 F&I Manhole 4' Dia Reinf Conc	EA	16.00	3,200.00	51,200.00
14 Connect Pipe to Exist Pipe	EA	2.00	1,500.00	3,000.00
15 Bore Pipe SDR 26 - 6" Dia PVC	LF	1,560.00	40.00	62,400.00
16 Bore Pipe SDR 26 - 12" Dia PVC	LF	70.00	83.00	5,810.00
17 F&I Pipe SDR 26 - 6" Dia PVC	LF	1,020.00	30.00	30,600.00
18 F&I Pipe SDR 35 - 12" Dia PVC	LF	3,670.00	32.00	117,440.00
19 F&I Pipe SDR 35 - 15" Dia PVC	LF	130.00	38.00	4,940.00
20 F&I Pipe w/GB SDR 35 - 12" Dia PVC	LF	625.00	57.00	35,625.00
21 F&I Pipe 20" Dia Steel	LF	70.00	310.00	21,700.00
			<b>Sanitary Sewer Total</b>	<b>334,015.00</b>
<b>Watermain</b>				
22 F&I Fittings C153 Ductile Iron	LB	3,212.00	5.00	16,060.00
23 F&I Hydrant - Restrained Joint	EA	14.00	4,200.00	58,800.00
24 Relocate Hydrant	EA	1.00	1,000.00	1,000.00
25 F&I Insulation 4" Thick	SY	6.00	11.00	66.00
26 Connect Pipe to Exist Pipe	EA	2.00	1,200.00	2,400.00
27 F&I Pipe C900 DR 18 - 6" Dia PVC	LF	135.00	26.00	3,510.00
28 F&I Pipe C900 DR 18 - 12" Dia PVC	LF	4,700.00	35.00	164,500.00
29 F&I Pipe w/GB C900 DR 18 - 12" Dia PVC	LF	270.00	54.00	14,580.00
30 F&I Gate Valve 6" Dia	EA	15.00	1,475.00	22,125.00
31 F&I Gate Valve 12" Dia	EA	9.00	3,100.00	27,900.00
32 F&I Hydrant Ext. 12" High	EA	2.00	750.00	1,500.00
33 F&I Hydrant Ext. 36" High	EA	1.00	1,200.00	1,200.00
			<b>Watermain Total</b>	<b>313,641.00</b>
<b>Storm Sewer</b>				

**ENGINEER'S STATEMENT OF ESTIMATED COST**  
**IMPROVEMENT DISTRICT # UN-18-C1**  
**Sanitary Sewer, Water Main, Storm Sewer & Incidentals**

34 F&I Manhole 4' Dia Reinf Conc	EA	1.00	2,000.00	2,000.00
35 F&I Manhole 5' Dia Reinf Conc	EA	9.00	3,150.00	28,350.00
36 F&I Manhole 6' Dia Reinf Conc	EA	3.00	4,300.00	12,900.00
37 F&I Manhole 7' Dia Reinf Conc	EA	5.00	5,500.00	27,500.00
38 F&I Manhole Type E Reinf Conc	EA	3.00	9,000.00	27,000.00
39 F&I Inlet - Manhole (MHI) 4' Dia Reinf Conc	EA	21.00	2,400.00	50,400.00
40 F&I Inlet - Single Box (SBI) Reinf Conc	EA	2.00	1,900.00	3,800.00
41 F&I Inlet - Round (RDI) Reinf Conc	EA	3.00	1,300.00	3,900.00
42 F&I Pipe 12" Dia Reinf Conc	LF	28.00	36.00	1,008.00
43 F&I Pipe 15" Dia Reinf Conc	LF	207.00	42.00	8,694.00
44 F&I Pipe 18" Dia Reinf Conc	LF	345.00	46.00	15,870.00
45 F&I Pipe 30" Dia Reinf Conc	LF	1,095.00	71.00	77,745.00
46 F&I Pipe 33" Dia Reinf Conc	LF	305.00	82.00	25,010.00
47 F&I Pipe 36" Dia Reinf Conc	LF	1,060.00	94.00	99,640.00
48 F&I Pipe 42" Dia Reinf Conc	LF	260.00	120.00	31,200.00
49 F&I Pipe 48" Dia Reinf Conc	LF	865.00	145.00	125,425.00
50 F&I Pipe 66" Dia Reinf Conc	LF	710.00	195.00	138,450.00
51 F&I Pipe w/GB 15" Dia Reinf Conc	LF	430.00	52.00	22,360.00
52 F&I Pipe w/GB 18" Dia Reinf Conc	LF	70.00	55.00	3,850.00
53 F&I Pipe w/GB 36" Dia Reinf Conc	LF	70.00	108.00	7,560.00
54 F&I Pipe w/GB 42" Dia Reinf Conc	LF	70.00	135.00	9,450.00
55 F&I Pipe w/GB 48" Dia Reinf Conc	LF	10.00	170.00	1,700.00
56 F&I Pipe w/GB 66" Dia Reinf Conc	LF	65.00	215.00	13,975.00
57 F&I Rip Rap Rock	CY	60.00	75.00	4,500.00
58 F&I Flared End Section 12" Dia Reinf Conc	EA	1.00	1,100.00	1,100.00
59 F&I Flared End Section 66" Dia Reinf Conc	EA	1.00	5,300.00	5,300.00
60 Temp Pumping	LS	1.00	5,000.00	5,000.00
61 Rem & Repl Pavement 8" Thick Asph	SY	28.00	42.00	1,176.00
62 Connect Pipe to Exist Structure	EA	1.00	1,500.00	1,500.00
<b>Storm Sewer Total</b>				<b>756,363.00</b>
<b>Total Construction in \$</b>				<b>1,457,460.25</b>
Engineering		11.00 %		160,320.63
Legal & Misc		3.00 %		43,723.81
Contingencies		10.00 %		145,746.02
Administration		6.00 %		87,447.62
Interest		4.00 %		58,298.41
<b>Total Estimated Costs</b>				<b>1,952,996.74</b>
Special Assessments				1,952,996.74
<b>Unfunded Costs</b>				<b>0.00</b>

IN WITNESS THEREOF, I have hereunto set my hand and seal

Date: 10/03/2018



Tom Knakmuhs

Division Engineer

