

FARGO CITY COMMISSION AGENDA
Monday, June 17, 2019 - 5:00 p.m.

City Commission meetings are broadcast live on TV Fargo Channel 56 and online at www.FargoND.gov/streaming. They are rebroadcast Mondays at 5:00 p.m., Thursdays at 7:00 p.m. and Saturdays at 8:00 a.m. They are also included in the video archive at www.FargoND.gov/citycommission.

- A. Pledge of Allegiance.
- B. Roll Call.
- C. Approve Order of Agenda.
- D. Minutes (Regular Meeting, June 3, 2019).

CONSENT AGENDA – APPROVE THE FOLLOWING:

- 1. 1st reading of an Ordinance Amending Section 25-1506 of Article 25-15 of Chapter 25 of the Fargo Municipal Code Relating to Restrictions on Sale, Service or Dispensing of Alcoholic Beverages.
- 2. 2nd reading and final adoption of the following Ordinances; 1st reading, 6/3/19:
 - a. Rezoning Certain Parcels of Land Lying in Fitzsimonds Addition.
 - b. Rezoning Certain Parcels of Land Lying in Huntington's Addition.
- 3. Applications for property tax exemptions for improvements made to buildings:
 - a. Hardy Family LP, 1817 7th Street South (4 year).
 - b. Ricky L. Engebretson, 809 Kennedy Court North (5 year).
 - c. Amy J. Hoepfner and Marilyn J. Lewis, 1506 6th Street South (5 year).
- 4. Renewal of Alcoholic Beverage Licenses and Live Entertainment Licenses until 6/30/20, contingent upon all essential requirements for renewal being met by 6/30/19.
- 5. General Fund – Budget to Actual through May 2019 (unaudited).
- 6. Site Authorizations for Games of Chance:
 - a. Special Olympics ND at Rooters Bar.
 - b. Prairie Public Broadcasting, Inc. at Peppers.
 - c. Jon Greenley Amvets Post #7 at Hi-Ho Burgers & Brews.
- 7. Applications for Games of Chance:
 - a. El Zagal Shrine – Provost Guard for a raffle from 5/31/19 to 9/5/19.
 - b. Haiti Eye Mission for a raffle on 8/5/19; Public Spirited Resolution.
 - c. River Keepers for a raffle on 8/19/19 (amended).
 - d. FM AM Rotary Club for a sports pool from 9/9/19 to 2/2/20.
 - e. Steve Weidner FM Junior Tour for a raffle board and calendar raffle from 7/1/19 to 6/30/20.
- 8. Amendment to the Art Wrap Agreement with the Downtown Community Partnership BID.

Release of Negative Access Easement.

10. Bid award for Project No. PR-19-C1.
11. Sole Source Procurement with AVI Systems Inc., in the amount of \$501,104.46, for replacement of the FARGODOME arena public address sound system.
12. Purchase of Service Agreement with Fargo Public School District for nursing services in the 2019-2020 school year.
13. Submission of the CDBG and HOME Programs 2019 Action Plan and Budget, and Amendments to the 2018 Action Plan Activities and Budget/5-Year Consolidated Plan Activity to HUD.
14. Change Order No. 3 for a decrease of \$9,801.00 for the Parking Facilities Restoration projects.
15. Task Order No. 21 with AE2S in the amount of \$315,300.00 for Project No. WA1863.
16. Change Orders for Project No. SW16-03 Phase II:
 - a. No. 4 for an increase of \$4,225.27 for the general contract.
 - b. No. 6 for an increase of \$13,394.00 for the mechanical contract.
 - c. No. 7 for an increase of \$5,019.00 for the mechanical contract.
 - d. No. 8 for an increase of \$1,341.00 for the mechanical contract.
 - e. No. 9 for an increase of \$1,778.00 for the mechanical contract.
 - f. No. 4 for an increase of \$1,075.00 for the electrical contract.
 - g. No. 5 for an increase of \$2,395.00 for the electrical contract.
17. Contract and bond for Project No. WA 1862.
18. Bid award for one automated side loader refuse truck (RFP19086).
19. Bills.
20. Contract Amendment No. 2 in the amount of \$33,042.00 with Houston Engineering for Improvement District No. BN-19-A3.
21. Change Orders for Improvement District No. BN-19-A2:
 - a. No. 1 for an increase of \$0.00.
 - b. No. 2 for an increase of \$0.00.
 - c. No. 3 for an increase of \$5,255.00.
 - d. No. 4 for an increase of \$1,320.00.
 - e. No. 5 for an increase of \$15,101.89.
 - f. No. 6 for an increase of \$13,647.00.
 - g. No. 7 for an increase of \$0.00.
22. Change Order No. 4 for an increase of \$4,905.00 for Improvement District No. BN-18-K1.
23. Change Order No. 4 for an increase of \$368.08 for Improvement District No. BR-18-E1.
24. Final Balancing Change Order No. 2 for an increase of \$8,161.81 for Improvement District No. BN-18-B1.

- Page 25
25. Final Balancing Change Order No. 3 for an increase of \$784.87 for Improvement District No. BN-18-J1.
 26. Selection of Alternative B1 with Option B for the design of 64th Avenue South (Improvement District No. PN-19-A1).
 27. Bid award for Improvement District No. SL-19-B1.

REGULAR AGENDA:

28. Recommendations for appointments and reappointments to the following Boards and Commissions:
 - a. Board of Appeals.
 - b. Native American Commission.
 - c. Planning Commission.
 - d. Tax Exempt Review Committee.
29. Public Hearings - 5:15 pm:
 - a. CONTINUE to 7/1/19 - Zoning change to repeal and re-establish a C-O, Conditional Overlay, Timber Parkway Third Addition; denial recommended by the Planning Commission on 5/7/19; continued from the 6/3/19 Regular Meeting:
 1. 1st reading of rezoning Ordinance.
30. Request for Services with Bishop Land Design for Site and Landscape Design Services, and Solicitation of a Construction Manager at Risk through a Request for Qualifications process.

People with disabilities who plan to attend the meeting and need special accommodations should contact the Commission Office at 701.241.1310. Please contact us at least 48 hours before the meeting to give our staff adequate time to make arrangements.

Minutes are available on the City of Fargo website at www.FargoND.gov/citycommission.

OFFICE OF THE CITY ATTORNEY
FARGO, NORTH DAKOTA

①

ORDINANCE NO. _____

AN ORDINANCE AMENDING SECTION 25-1506 OF ARTICLE 25-15
OF CHAPTER 25 OF THE FARGO MUNICIPAL CODE RELATING
TO RESTRICTIONS ON SALE, SERVICE OR DISPENSING OF
ALCOHOLIC BEVERAGES

WHEREAS, the electorate of the city of Fargo has adopted a home rule charter in accordance with Chapter 40-05.1 of the North Dakota Code; and,

WHEREAS, Section 40-05.1-06 of the North Dakota Century Code provides that the City shall have the right to implement home rule powers by ordinance; and,

WHEREAS, Section 40-05.1-05 of the North Dakota Century Code provides that said home rule charter and any ordinances made pursuant thereto shall supersede state laws in conflict therewith and shall be liberally construed for such purposes; and,

WHEREAS, the Board of City Commissioners deems it necessary and appropriate to implement such authority by the adoption of this ordinance;

NOW, THEREFORE,

Be It Ordained by the Board of City Commissioners of the City of Fargo:

Section 1. Amendment.

Section 25-1506 of Article 25-15 of Chapter 25 of the Fargo Municipal Code is hereby amended to read as follows:

* * *

L. Class FA-GOLF. A Class "FA-GOLF" license shall authorize the licensee to sell "on-sale" only, subject to the following restrictions and conditions:

1. A Class "FA-GOLF" licensee may sell alcoholic beverages as the food and beverage concessionaire at a golf course which also holds a restaurant license or permit pursuant to the provisions of article 13-04 of the Fargo Municipal Code and which derives a percentage (hereinafter stated) of its gross receipts from the sale of prepared meals and not alcoholic beverages. A recipient of "FA-GOLF" license must derive at least 25% of its gross

OFFICE OF THE CITY ATTORNEY
FARGO, NORTH DAKOTA

ORDINANCE NO. _____

receipts from the sale of prepared meals and food products and not alcoholic beverages during the months from April through October of each year. During the remaining months of the year, said recipient must derive 50% or more of its gross receipts from the sale of prepared meals and not alcoholic beverages. It is the intention of this restriction that the purpose of a "FA-GOLF" license is to allow the sale of alcoholic beverages as an adjunct to the operation of the golf course and restaurant and not that of operating a full-time liquor establishment. Further, such licensee must be located at and serve a golf course of at least nine (9) or more holes. Said golf course must be USGA approved.

- 2. The Class "FA-GOLF" license shall authorize licensee to sell "on-sale" only and no licensee hereunder may conduct any "off-sale" liquor sales.
- 3. A licensee hereunder, which must also operate a restaurant under the provisions of this title, shall provide adequate off-street parking within the discretion of and subject to the approval of the commission.
- 4. A recipient of a license hereunder shall not be authorized to receive or be issued a live entertainment license as provided in section 25-1510. ~~Further, there shall be no charitable gambling or gaming of any kind.~~

* * * *

Section 2. Effective Date

This ordinance shall be in full force and effect from and after its passage and approval.

Section 3. Penalty.

A person who willfully violates this ordinance is guilty of an infraction. Every person, firm or corporation violating an ordinance which is punishable as an infraction shall be punished by a fine not to exceed \$1,000; the court to have power to suspend said sentence and to revoke the suspension thereof.

OFFICE OF THE CITY ATTORNEY
FARGO, NORTH DAKOTA

ORDINANCE NO. _____

- 1
- 2
- 3
- 4
- 5
- 6
- 7
- 8
- 9
- 10
- 11
- 12
- 13
- 14
- 15
- 16
- 17
- 18
- 19
- 20
- 21
- 22
- 23

(SEAL)

Timothy J. Mahoney, Mayor

Attest:

Steven Sprague, City Auditor

First Reading:
Second Reading:
Final Passage:
Publication:

LIQUOR CONTROL COMMITTEE MEETING
May 15, 2019 1:30 P.M.

Present: Commissioner Piepkorn, City Auditor Sprague, Aaron Johnson, Environmental Health,
Absent: Commissioner Gehrig, Police Chief Todd, Grant Larson, Environmental Health
Others Present: Assistant City Attorney Nancy Morris; Rick Carik, Rick's; Dustin Mitzel, Happy Harry's, Duane Litton, Duffy's; Dean Bachmeier, Buffalo Wild Wings, Pete Haug, Fargo Air Show; Dave Erickson, Bulldog Tap; Nikki Berglund, Luna; Jared Hardy, Fargo Brewing; Lisa Meyer, Wurst; ; Joe Burgum, Carol Schlossman, Josi Danz, Downtown Neighborhood Association, Other members of the media, concerned citizens and other members of the industry.

Meeting was called to order at 1:30 P.M.

1. Commissioner Piepkorn called the meeting to order and asked if there were any additions or corrections to the minutes of April 17, 2019. There were no additions or corrections to the minutes of April 17, 2019. Moved by Sprague, seconded by Johnson to approve the minutes of the April 17, 2019 meeting of the Liquor Control Board all voted in favor, motion passed unanimously.
2. A. The first application to consider today is the issuance of a Class "GH" alcoholic beverage license to Bernbaum, Inc. d/b/a Bernbaum's located at 402 Broadway.

Moved by Sprague, seconded by Johnson to approve the issuance of a Class "GH" alcoholic beverage license to Bernbaum, Inc. d/b/a Bernbaum's located at 402 Broadway. Motion approved unanimously.
- B. The second application to consider today is the issuance of a Class "F" alcoholic beverage license to Brew Bird, Inc. d/b/a Brew Bird located at 30 University Drive North. Issues noted in the background check are old and no longer a concern.

Moved by Sprague, seconded by Johnson to approve the issuance of a Class "F" alcoholic beverage license to Brew Bird, Inc. d/b/a Brew Bird located at 30 University Drive North. Motion approved unanimously.
- C. The fourth application to be considered today is for the transfer of a Class FA-Golf alcoholic beverage license from BCZ Osgood Holdings, LLC d/b/a 9 Iron Bar & Grill to Brickhouse Tavern, LLC d/b/a Brewtus Clubhouse to be located at 4400 Clubhouse Drive. The issues noted in the background check are older and no longer a concern.

Moved by Sprague, seconded by Johnson to approve the transfer of a Class FA-Golf alcoholic beverage license from BCZ Osgood Holdings, LLC d/b/a 9 Iron Bar & Grill

to Brickhouse Tavern, LLC d/b/a Brewtus Clubhouse to be located at 4400 Clubhouse Drive. Motion passed.

3. The Liquor Control Board reviewed a request from Big Erv's @ Rose Creek and Brewtus Clubhouse to allow gaming with the FA-Golf license. Sprague commented that other FA license and the FA Entertainment license all allow gaming. Sprague also commented that there have been 5 operators at the Osgood golf course since it opened and perhaps adding gaming would allow the operator to be profitable. Moved by Sprague, seconded by Johnson to direct the City Attorney to prepare the necessary changes to the ordinance to allow gaming with the FA-Golf license classification. Motion passed.
4. The Liquor Control Board reviewed a request form the Fargo Air Show to allow patrons to carry open alcohol containers throughout the air show grounds. It was discussed and agreed that there shouldn't be much concern since the airshow is fenced and only happens 2 days every other year. Pete Haug representing the air show committee said they sought approval a number of years back but there don't appear to be any records of the request. Commissioner Piepkorn commented this should be similar to the DCP permit. Moved by Sprague, seconded by Johnson to direct the city attorney to work with the Air Show to amend the ordinance as required. Motion passed.
5. Sprague commented he received a copy of a letter from Jade Presents requesting to increase the number of amplified noise permits allowed each month. Currently applicants are allowed one amplified noise permit a month. Jared Hardy, Fargo Brewing, said they are looking to change the interpretation of the boundary for amplified sound. Where their business is located, it is removed from single-family residential property. Lee Swartz, Jade Presents, said outdoor events are critical to the business plan; they help bring energy to the neighborhood. He said train noise in the area is already significant. Commission Piepkorn asked if they had reached out to the Roosevelt neighborhood. Swartz commented they would do that in the near future. Piepkorn commented the original license was to be a brewery. Sprague said this is a Planning issue but he wanted the Liquor Board to be aware of the request.
6. Sprague said he received a request from The Boiler Room to expand their licensed premise into the are formerly occupied by Stumbeanos. He said the area is contiguous to the existing licensed premise. Moved by Sprague, seconded by Johnson to allow the requested expansion. Motion passed.
7. Piepkorn suggested that we continue the discussion about the penalty matrix until the next meeting so the Chief can be present.

There being no further business to come before the Liquor Control Board, the meeting was adjourned at 1:48 p.m. **The next regular meeting will be held Wednesday, June 19, 2019 at 1:30 p.m. in the City Commission Room.**



Big Erv's Bar & Grill
412 Main Street
Horace, ND 58047

Phone: 701.371.5180

Email: kelly@bigervs.com

Mr. Sprague,

I am writing you today regarding the current FA-Golf License language that does not allow Charitable gaming. I have visions of Big Erv's at Rose Creek teaming up with a local Non-Profit which could operate gaming in our location. In Horace we currently work with the Horace Lions Club and they operate games like 21 (Blackjack), Video Pull tabs, Bingo and Meat Raffles. Every Saturday afternoon we have Bingo which lasts around 2 -3 hours long, it is so busy that patrons are showing up at least an hour before Bingo starts. We see food and liquor sales continuing to flourish due to Bingo and Video Tabs.

Lastly, gaming has been a positive for Big Erv's and the Horace Lions Club to give back to the community. I am very proud to say in 2018 the Lions Club donated over \$80,000 to charity just from funds gained from Big Erv's gaming site.

I look forward to answering any questions you may have and thank you for your consideration!

Kelly R. Visto

Big Erv's Bar & Grill
Ph# 701-371-5180
kelly@bigervs.com

BRICKHOUSE TAVERN, LLC
4627 44TH AVE S. STE 101
FARGO, ND 58104
PH. (701) 367-4836

April 22, 2019

City of Fargo
Attn: Steven Sprague
225 N. 4th St
PO Box 2471
Fargo, ND 58108

Re: Brickhouse Tavern, LLC/Don. Brewtus' Clubhouse

Dear Mr. Sprague

I am writing to express our interest in adding charitable gaming to our newest restaurant and bar venture Brewtus' Clubhouse located at Osgood Golf Course in Fargo, ND.

Currently our company operates Brewtus' Brickhouse in both West Fargo, ND and Moorhead, MN. Both location have onsite charitable gaming which has been well received by the patrons. We would love to be able to offer that opportunity to our Fargo patrons at Brewtus' Clubhouse at Osgood Golf Course.

I would be happy to discuss this request with you in person or by phone at (701) 367-4836.

Your time and consideration is greatly appreciated.

Sincerely,

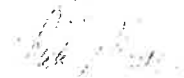

Rick Morris, President

OFFICE OF THE CITY ATTORNEY
FARGO, NORTH DAKOTA

2a

ORDINANCE NO. _____

1 AN ORDINANCE REZONING CERTAIN PARCELS
2 OF LAND LYING IN FITZSIMONDS ADDITION
3 TO THE CITY OF FARGO, CASS COUNTY, NORTH DAKOTA

4 WHEREAS, the Fargo Planning Commission and the Board of City Commissioners of the
5 City of Fargo have held hearings pursuant to published notice to consider the rezoning of certain
6 parcels of land lying in Fitzsimonds Addition to the City of Fargo, Cass County, North Dakota; and,

7 WHEREAS, the Fargo Planning Commission recommended approval of the rezoning
8 request on May 7, 2019; and,

9 WHEREAS, the rezoning changes were approved by the City Commission on June 3, 2019,

10 NOW, THEREFORE,

11 Be It Ordained by the Board of City Commissioners of the City of Fargo:

12 Section 1. The following described property:

13 Lots One (1) through Seven (7), Block One (1) of Fitzsimonds Addition to the City
14 of Fargo, Cass County, North Dakota;

15 that is currently zoned as a "GC", General Commercial, District with a "C-O", Conditional
16 Overlay, as established by Fargo City Ordinance Number 4636 is hereby rezoned only to amend the
17 "C-O", Conditional Overlay as established by said Ordinance No. 4636 as follows:

- 18 1. This Conditional Overlay is intended to provide for a higher quality of design than is
19 afforded by the City of Fargo Land Development Code regarding the future
20 commercial development of McShane Development.
- 21 2. All primary buildings shall be constructed or clad with materials that are durable,
22 economically-maintained, and of a quality that will retain their appearance over
23 time, including but not limited to natural or synthetic stone; brick; stucco; integrally
colored, textured or glazed concrete masonry units; high-quality pre-stressed concrete
systems; or glass. Natural wood or wood paneling shall not be used as a principal exterior
wall material, but durable synthetic materials with the appearance of wood may be used.
3. Color schemes shall tie building elements together, relate pad buildings within the
same development to each other, and shall be used to enhance the architectural form

OFFICE OF THE CITY ATTORNEY
FARGO, NORTH DAKOTA

ORDINANCE NO. _____

of a building.

1 4. ~~All building façades greater than 150 feet in length, measured horizontally, shall~~
2 ~~incorporate wall plane projections or recesses having a depth of at least three percent~~
3 ~~of the length of the façade, and extending at least 20 percent of the length of the~~
4 ~~façade. No uninterrupted length of any façade shall exceed 150 horizontal feet. An~~
~~articulated façade would emphasis elements on the face of a wall including change~~
~~in setback, materials, roof pitch or height.~~

5 4. All building façades greater than 200 feet in length, measured horizontally, shall
6 incorporate wall plane projections or recesses having a depth of at least three percent of
7 the length of the façade, and extending at least 20 percent of the façade. No uninterrupted
8 length of façade shall exceed 200 horizontal feet. An articulated façade would emphasize
9 elements on the face of a wall including change in setback, materials, roof pitch, or
10 height.

11 i. All buildings shall have architectural interest and variety to avoid the effect of a
12 single, long or massive wall; buildings shall include a variation in size and shape.

13 ii. All building elevations or façades facing or viewable from right-of-ways or
14 parking lots that are greater than 200 feet in length, measured horizontally from
15 vertical edge to vertical edge, shall incorporate wall plane projections or recesses.
16 Each projection and/or recess shall have a depth of at least five feet, and the
17 cumulative horizontal width of all projections and/or recesses within a façade
18 shall equate to at least an accumulated total of 20 percent of the overall horizontal
19 length of the façade. No uninterrupted length of any façade shall exceed 200
20 horizontal feet. Attached or adjacent permanent wall projections that screen
21 maintenance/loading/delivery/ dumpsters that exceed 9 feet in height shall count
22 as projections and recesses.

23 iii. Ground floor façades that are within 200 feet of the right-of-way, measured from
the exterior wall, shall have arcades, display windows, entry areas, awnings,
spandrel glass, ground level landscaping, or other such features along no less than
60% of its horizontal length.

iv. All building elevations or façades facing or viewable from the rights-of-way or
parking lots shall be designed with a similar level of design detail, respective to
building massing and building materials.

5. Ground floor façades that face public streets shall have arcades, display windows,
entry areas, awnings, or other such features along no less than 60 percent of their
horizontal length. If the façade facing the street is not the front, it shall include the

OFFICE OF THE CITY ATTORNEY
FARGO, NORTH DAKOTA

ORDINANCE NO. _____

same features and/or landscaping in scale with the façade.

1 ~~6. Flat roofs and rooftop equipment, such as HVAC units, shall be concealed from~~
2 ~~public view by parapets, including but not limited to the back of the structure. The~~
3 ~~average height of such parapets shall not exceed one third of the height of the~~
4 ~~supporting wall, and such parapets shall not be of a constant height for a distance of~~
5 ~~greater than 150 feet.~~

6 6. Flat roofs and rooftop equipment, such as HVAC units, shall be screened to a minimum
7 of half the height of the unit by parapets and/or screens, including but not limited to the
8 back of the structure

9 7. Loading facilities shall not be located at the front of structures where it is difficult to
10 adequately screen them from view. All loading and service areas shall be screened
11 from the view of adjacent public streets through a structure and/or landscaping.

12 8. Dumpsters and outdoor storage areas must be completely screened from view.
13 Collection area enclosures shall contain permanent walls on three (3) sides with the
14 service opening not directly facing any public right-of-way or residentially zoned
15 property. The fourth side shall incorporate a metal gate to visually screen the
16 dumpster or compactor.

17 9. Separate vehicular and pedestrian circulation systems shall be provided. An on-site
18 system of pedestrian walkways shall be designed to provide direct access and
19 connections to and between the following:

- 20 a. the primary entrance or entrances to each commercial building, including
21 pad site buildings.
- 22 b. any sidewalks or walkways on adjacent properties that extend to the boundaries
23 shared with the commercial development.
- 24 c. parking areas or structures that serve such primary buildings.
- 25 d. connections between the on-site (internal) pedestrian walkway network and
26 any public sidewalk system located along adjacent perimeter streets shall be
27 provided at regular intervals along the perimeter street as appropriate to
28 provide easy access from the public sidewalks to the interior walkway
29 network.
- 30 e. any public sidewalk system along the perimeter streets adjacent to the
31 commercial development.

OFFICE OF THE CITY ATTORNEY
FARGO, NORTH DAKOTA

ORDINANCE NO. _____

- 1 f. where practical and appropriate, adjacent land uses and developments, including
2 but not limited to residential developments, retail shopping
3 centers, office buildings.

4 10. On-premise signs

- 5 a. Every structure and complex should be designed with a precise concept for
6 adequate signing. Provisions for sign placement, sign scale in relationship
7 with the building, and sign readability should be considered in developing
8 the signing concept.
- 9 b. Signage size, color and form should complement the architecture of the
10 building and should not compete or become the focal point of the building
11 form.
- 12 c. Signage must not extend horizontally or vertically past the building.
- 13 d. Signage text should be legible from arterial streets, use of recognizable
14 imagery can be substituted for legibility of text. Sign should not be larger
15 than necessary to achieve this legibility from the street.
- 16 e. Sign surface areas must be less than 10% of the building surface.
- 17 f. Signs should be located horizontally above first floor doors and windows, on
18 awnings, or adjacent to building entrances if mounted on a wall.
- 19 g. Corporate logos should be appropriately scaled.
- 20 h. Separate pedestrian oriented signs should be provided when pedestrians
21 cannot see the façade signage which is oriented to the street.
- 22 i. Each development site should be appropriately signed to give directions to
23 loading and receiving areas, visitor parking and other special areas.
- 24 j. Multi-tenant buildings or developments may have one monument or ground
25 mounted sign per street frontage listing all of the tenants. Monument or
26 ground mounted signs for individual businesses in multi-tenant buildings or
27 developments are prohibited. Monument-type signs are the preferred
28 alternative for business identification whenever possible.
- 29 k. Signs should advertise a specific building or business, not products,
30 trademarks, or special events.
- 31 l. Window signs used for shop fronts or mixed use building are permitted
32 provided that the aggregate total of all window signs for each business
33 shall not exceed 25% of its respective window area.
- 34 ~~m. No on premise sign shall exceed forty five (45) feet in height.~~
- 35 m. One on-premise, static, multi-tenant sign, positioned to be visible from Interstate

OFFICE OF THE CITY ATTORNEY
FARGO, NORTH DAKOTA

ORDINANCE NO. _____

29. may be up to 60 feet in height. Otherwise, no on premise sign shall exceed forty-five (45) feet in height.

11. A minimum of 4.5% of the internal surface area of the parking lot shall be landscaped. The cumulative open space (green space) of each lot shall consist of at least 15% of the lot.
12. The following use(s) are prohibited.
 - a. Detention Facilities
 - b. Adult Entertainment Center
 - c. Off-Premise Advertising Signs (directional signs that are less than 50 square feet in size are exempt for this prohibition)
 - d. Portable Signs
 - e. Vehicle Repair
 - f. Industrial Service
 - g. Manufacturing and Production
 - h. Warehouse and Freight Movement
 - i. Aviation/Surface Transportation
13. The Zoning Administrator shall review each applicable Site Plan to determine compliance with this Conditional Overlay and act to approve or deny the Site Plan application.
14. The decision of the Zoning Administrator may be appealed to the Planning Commission.

Section 2. The City Auditor is hereby directed to amend the zoning map now on file in his office so as to conform with and carry out the provisions of this ordinance.

OFFICE OF THE CITY ATTORNEY
FARGO, NORTH DAKOTA

ORDINANCE NO. _____

Section 3. This ordinance shall be in full force and effect from and after its passage and approval.

1
2
3
4
5
6
7
8
9
10
11
12
13
14
15
16
17
18
19
20
21
22
23

(SEAL)

Attest:

Steven Sprague, City Auditor

Timothy J. Mahoney, M.D., Mayor

First Reading:
Second Reading:
Final Passage:

OFFICE OF THE CITY ATTORNEY
FARGO, NORTH DAKOTA

26

ORDINANCE NO. _____

1 AN ORDINANCE REZONING CERTAIN PARCELS
2 OF LAND LYING IN HUNTINGTON'S ADDITION
3 TO THE CITY OF FARGO, CASS COUNTY, NORTH DAKOTA

4 WHEREAS, the Fargo Planning Commission and the Board of City Commissioners of the
5 City of Fargo have held hearings pursuant to published notice to consider the rezoning of certain
6 parcels of land lying in Huntington's Addition to the City of Fargo, Cass County, North Dakota;
7 and,

8 WHEREAS, the Fargo Planning Commission recommended approval of the rezoning
9 request on May 7, 2019; and,

10 WHEREAS, the rezoning changes were approved by the City Commission on June 3, 2019,

11 NOW, THEREFORE,

12 Be It Ordained by the Board of City Commissioners of the City of Fargo:

13 Section 1. The following described property:

14 Lot Twenty-four (24), Block Thirteen (13) of Huntington's Addition to the City of
15 Fargo, Cass County, North Dakota;

16 is hereby rezoned from "SR-2", Single-Dwelling Residential, District to "P/I", Public and
17 Institutional, District;

18 Section 2. The City Auditor is hereby directed to amend the zoning map now on file in his
19 office so as to conform with and carry out the provisions of this ordinance.
20
21
22
23

OFFICE OF THE CITY ATTORNEY
FARGO, NORTH DAKOTA

ORDINANCE NO. _____

Section 3. This ordinance shall be in full force and effect from and after its passage and approval.

1
2
3
4
5
6
7
8
9
10
11
12
13
14
15
16
17
18
19
20
21
22
23

(SEAL)

Attest:

Steven Sprague, City Auditor

Timothy J. Mahoney, M.D., Mayor

First Reading:
Second Reading:
Final Passage:

CITY OF
Fargo
ASSESSMENT DEPARTMENT

3a

June 6, 2019

Board of City Commissioners
City Hall
Fargo, ND 58102

Dear Commissioners:

Chapter 57-02.2 of the North Dakota Century Code provides for a property tax exemption for certain types of improvements made to existing buildings.

I have attached a copy of an application for real estate tax exemption of building improvements for the property at 1817 7 St. S as submitted by Hardy Family LP. A description of the property involved, types of improvements to be made, and assessment information are indicated on the application.

It is my opinion that the value of some of the improvements, referred to in the application, qualifies for the exemption. This exemption would be for the years 2017, 2018, 2019, & 2020.

The estimated annual tax revenue lost by granting the exemption, based upon the estimated cost of the improvements, would be about \$1560 with the City of Fargo's share being \$265.

Sincerely,



Ben Hushka
City Assessor

hah
attachment

**Application For Property Tax Exemption For Improvements
To Commercial And Residential Buildings
North Dakota Century Code ch. 57-02.2
(File with the local city or township assessor)**

Property Identification

1. Name of Property Owner Hardy Family Partnership Phone No. 7012122995

2. Address of Property 1817 7th St S

City FARGO State ND Zip Code 58103

3. Legal description of the property for which the exemption is being claimed. Lot 20 Block 3 Harry A Schnell Addition

4. Parcel Number 01-2660-00690-000 Residential Commercial Central Business District

5. Mailing Address of Property Owner 1817 7th St S

City Fargo State ND Zip Code 58103

Description Of Improvements For Exemption

6. Describe the type of renovating, remodeling or alteration made to the building for which the exemption is being claimed (attach additional sheets if necessary). Full Kitchen Remodle, New Plumbing, New Fixtkures
New Electrical Panel and Lighting, Updated bathroom, Updated Flooring, New Water Heater, New Furnace

7. Building Permit No. Unsure (JDP Electric) 8. Year Built 1956

9. Date of Commencement of making the improvement Sept. 2015 to Present

10. Estimated market value of property before improvement \$ 165,700

11. Cost of making the improvement (all labor, material and overhead) \$ 120,000

12. Estimated market value of property after improvement \$ 216000

Applicant's Certification and Signature

13. I certify that the above information is correct to the best of my knowledge and I apply for this exemption.

Applicant's Signature Rachel Hardy Date 6/4/2019

Assessor's Determination

14. The local assessor finds that the improvements in this application has has not met the qualifications for exemption for the following reason(s): 4 YEARS FOR QUALIFYING WORK

Assessor's Signature Jim Mueller Date 6/7/19

Action of Governing Body

15. Action taken on this application by local governing board of the county or city: Denied Approved

Approval subject to the following conditions: _____

Chairman of Governing Body _____ Date _____

CITY OF
Fargo
ASSESSMENT DEPARTMENT

36

June 6, 2019

Board of City Commissioners
City Hall
Fargo, ND 58102

Dear Commissioners:

Chapter 57-02.2 of the North Dakota Century Code provides for a property tax exemption for certain types of improvements made to existing buildings.

I have attached a copy of an application for real estate tax exemption of building improvements for the property at 809 Kennedy Ct. N as submitted by Ricky L. Engebretson. A description of the property involved, types of improvements to be made, and assessment information are indicated on the application.

It is my opinion that the value of some of the improvements, referred to in the application, qualifies for the exemption. This exemption would be for the years 2019, 2020, 2021, 2022, & 2023.

The estimated annual tax revenue lost by granting the exemption, based upon the estimated cost of the improvements, would be about \$415 with the City of Fargo's share being \$70.

Sincerely,



Ben Hushka
City Assessor

hah
attachment

**Application For Property Tax Exemption For Improvements
To Commercial And Residential Buildings**
North Dakota Century Code ch. 57-02.2
(File with the local city or township assessor)

Property Identification

1. Name of Property Owner RICKY ENGBRETSON Phone No. 701-261-3279

2. Address of Property 809 KENNEDY CT
City FARGO State ND Zip Code 58102

3. Legal description of the property for which the exemption is being claimed. L+14 BIK 2 Montplaisirs Subd, Chapins

4. Parcel Number 01-0440-0299000 Residential Commercial Central Business District

5. Mailing Address of Property Owner 15 BROADWAY N, STE 205
City FARGO State ND Zip Code 58102

Description Of Improvements For Exemption

6. Describe the type of renovating, remodeling or alteration made to the building for which the exemption is being claimed (attach additional sheets if necessary). RENOVATED KITCHEN, BATH & BASEMENT.

7. Building Permit No. NONE 8. Year Built 1926

9. Date of Commencement of making the improvement Sept. 2018

10. Estimated market value of property before improvement \$ 120,600

11. Cost of making the improvement (all labor, material and overhead) \$ 81,500.00

12. Estimated market value of property after improvement \$ 152,600

Applicant's Certification and Signature

13. I certify that the above information is correct to the best of my knowledge and I apply for this exemption.
Applicant's Signature [Signature] Date 3/20/19

Assessor's Determination

14. The local assessor finds that the improvements in this application has has not met the qualifications for exemption for the following reason(s) 5 YEARS FOR QUALIFYING WORK
Assessor's Signature [Signature] Date 6/7/19

Action of Governing Body

15. Action taken on this application by local governing board of the county or city: Denied Approved
Approval subject to the following conditions: _____
Chairman of Governing Body _____ Date _____

CITY OF
Fargo
ASSESSMENT DEPARTMENT



June 6, 2019

Board of City Commissioners
City Hall
Fargo, ND 58102

Dear Commissioners:

Chapter 57-02.2 of the North Dakota Century Code provides for a property tax exemption for certain types of improvements made to existing buildings.

I have attached a copy of an application for real estate tax exemption of building improvements for the property at 1506 6 St. S as submitted by Amy J. Hoepfner & Marilyn J. Lewis. A description of the property involved, types of improvements to be made, and assessment information are indicated on the application.

It is my opinion that the value of some of the improvements, referred to in the application, qualifies for the exemption. This exemption would be for the years 2019, 2020, 2021, 2022, & 2023.

The estimated annual tax revenue lost by granting the exemption, based upon the estimated cost of the improvements, would be about \$115 with the City of Fargo's share being \$20.

Sincerely,

A handwritten signature in cursive script, appearing to read 'Ben Hushka', written over a horizontal line.

Ben Hushka
City Assessor

hah
attachment

**Application For Property Tax Exemption For Improvements
To Commercial And Residential Buildings**
North Dakota Century Code ch. 57-02.2
(File with the local city or township assessor)

Property Identification

1. Name of Property Owner AMY HOEPFNER & MARILYN LEWIS Phone No. 701-799-3810

2. Address of Property 1506 6 ST S

City FARGO State ND Zip Code 58103

3. Legal description of the property for which the exemption is being claimed. LT 19 BLK 15 HUNTINGTONS

4. Parcel Number 01-1400-02480-000 Residential Commercial Central Business District

5. Mailing Address of Property Owner 1506 6 ST S

City FARGO State ND Zip Code 58103

Description Of Improvements For Exemption

6. Describe the type of renovating, remodeling or alteration made to the building for which the exemption is being claimed (attach additional sheets if necessary). RESIDE DWELLING

7. Building Permit No. 180045 8. Year Built 1948

9. Date of Commencement of making the improvement NOV 2018

10. Estimated market value of property before improvement \$ 177,300

11. Cost of making the improvement (all labor, material and overhead) \$ 16,573

12. Estimated market value of property after improvement \$ _____

Applicant's Certification and Signature

13. I certify that the above information is correct to the best of my knowledge and I apply for this exemption.

Applicant's Signature [Signature] Date 5-20-19

Assessor's Determination

14. The local assessor finds that the improvements in this application has has not met the qualifications for exemption for the following reason(s): 5 YEARS FOR QUALIFYING WORK

Assessor's Signature [Signature] Date 6/7/19

Action of Governing Body

15. Action taken on this application by local governing board of the county or city: Denied Approved

Approval subject to the following conditions: _____

Chairman of Governing Body _____ Date _____

4

MEMORANDUM

TO: BOARD OF CITY COMMISSIONERS

FROM: STEVEN SPRAGUE, CITY AUDITOR

SUBJECT: 2019-2020 ALCOHOL BEVERAGE LICENSE RENEWAL

DATE: JUNE 17, 2019

Attached is a list of 197 alcoholic beverage establishments seeking renewal of their Liquor and Live Entertainment licenses through June 30, 2019. These licenses are eligible for renewal subsequent to all requirements being fulfilled.

All food and alcohol sales ratio reports are on file in the Auditor's Office and may be reviewed upon your request.

The licenses are eligible for renewal after fulfilling the renewal requirements. The renewal requirements include:

- Completion and submission of license renewal form
- Submission of a current roster including hiring date
- All servers and wait staff must have attended server training
- Attend required mandatory annual meeting
- Submission of a CPA statement or sales tax forms indicating the food percentage has been meet (where applicable)

If you have any questions regarding this matter, please feel free to contact me.

Recommended Motion:

Approve the renewal of the attached Liquor and Live Entertainment licenses until June 30, 2020, upon the condition that all of the essential requirements for renewal are present by June 30, 2019.

DBA Name	Location	Class
46 North Pints & Provisions	635 2 Ave N	FA
Acapulco Mexican Restaurant	1150 36 St S	F
AmericInn Fargo	4325 23 Ave S	ABH-Limited
Amvets	1001 1st Avenue South	AC
Applebee's Neighborhood Bar and Grill	2350 45 St S	FA
Applebee's Neighborhood Bar and Grill	2001 16 St N	FA
Applebee's Neighborhood Grill & Bar	2800 13 Ave S	FA
Auger Inn All Ranks Club	Hector Field	J
Avalon Event Center West	2525 9th Ave S	FA
Baymont Inn & Suites	1340 21 Ave S	ABH
Bernbaum's	402 Broadway N	GH
Bernie's Wines & Liquors	1557 South University Drive	B
Best Western Plus Kelly Inn & Suites	1767 44th St S	ABH-Limited
Big Erv's at Rose Creek	1500 Rose Creek Parkway	FA-Golf
Bismarck Tavern	522 Broadway	AB
Bison Turf	1211 North University Drive	AB
Black Coffee and Waffle Bar	550 2 Ave N	GH
Blackbird Woodfire	206 Broadway	GH
Blaze Pizza	1443 42 St S	GH
Borrowed Bucks	1201 Westrac Drive	A
Bottle Barn Liquors	2515 Univ Dr S	B-M
Bowler	2630 University Dr S	AB
Brew Bird	30 University Drive N	F
Brewtus Clubhouse	4400 Clubhouse Drive	FA-Golf
Buffalo Wild Wings Grill & Bar	1501 42 St SW	A
Buffalo Wild Wings Grill & Bar	1515 19th Avenue North	FA
Cajun Cafe	1324 25 Ave S	F
Candlewood Suites	1831 NDSU Research Park Dr	ABH-Limited
Cash Wise Liquor	1414 34 St S	B
Cash Wise Liquor 2	4985 Timber Parkway S	B-Limited
Chef's Table Private Dining & Events	670 4 Ave N	FA
Chili's	3902 13th Avenue SW	FA
Chipotle Mexican Grill	1680 45 St S	F
Chub's Pub	421 North University Drive	AB
Chuck E. Cheese	1202 Nodak Drive	H
Concessions Management	5225 31 Ave S	N
Cowboy Jacks	506 Broadway N	A
Crooked Pint Ale House	3340 13th Avenue South	FA
Deep Blue Seafood	4480 23 Ave S Suite 4	GH
Delta Hotels	1635 42nd Street S	ABH
Dempsey's Public House	226 Broadway	Z
Divot's at Edgewood	19 Golf Course Ave NE	FA-GOLF
Doolittles Woodfire Grill	2112 25 St S	FA
Drekker Brewing Company	1666 1 Ave N	Y
Drunken Noodle	414 Broadway	GH
Duffy's	16 12th Street South	AB

El Zagal	1429 3rd Street North	AC
Elks	3435 North Broadway	A
Empire Liquors West	4861 13 Ave SW	B
Empire Tavern	424 Broadway	AB
Expressway Suites	4303 17 Ave S	ABH-Limited
Famous Dave's BBQ	2581 45th Street SW	F
Fargo Billiards	3234 43 St S	FA-Entertainment
Fargo Brewing Company	610 N University Dr	C-M
Fargo Brewing Company Ale House	4445 17 Ave S, Suite #3	C-M
Fargo Cork	3301 South University Drive	AB
Fargo Country Club	509 26th Avenue South	AC
Fargo Courtyard	2249 55 St S	ABH
Fargo HuHot Mongolian Grill	1801 45 St S Unit J	GH
Fargo Residence Inn	4335 23 Ave S	ABH-Limited
Fargo Stopping Center	4510 19 Ave S	I
Fargo Suites	3316 13th Ave S	ABH
FargoDome	1800 North University Drive	N
Fargo-Moorhead Curling Club	4300 23 Ave S	AC
F-M Red Hawks	1515 15th Ave North	N
Fort Nok's	52 Broadway	Z
Four Points by Sheraton	5064 23 Ave S	FA
Frank's Lounge	2640 52 Ave S Suite A	Z
Front Street Taproom	614 Main Ave	CW-M
Garden Pavilion/One on One Catering	1421 7 Ave N	F
Golf Addiction	4474 23 Ave S	FA-Entertainment
Gorkha Palace	1000 45 St S Suite 300A	GH
Granite City Food & Brewery	1636 42nd Street SW	FA-M
Happy Harry's Bottle Shop	1621 45 St SW	B-M
Happy Harry's Bottle Shop	1125 19 Ave N	B-M
Happy Harry's Bottle Shop	4001 53 Ave S	AB-M
Happy Joe's Pizza	2511 South University Drive	H
Hawthorn Suites by Wyndham	4014 17 Ave S	ABH-Limited
Hennessy's Irish Pub	4323 45 St S #101	A
Herd & Horns	1414 12 Ave N Suite F	FA
Hi-Ho South	3051 25th Street SW	I
Hilton Garden Inn	4351 17 Ave S	ABH
Himalayan Yak	1450 25 St S #160	GH
Holiday Inn Express I-94	4711 19 Ave S	ABH-Limited
Holiday Inn Express-West Acres	1040 40 St SW	ABH-Limited
Holiday Inn of Fargo	3803 13th Avenue South	ABH
Homewood Suites by Hilton	2021 16 St N	ABH-Limited
Hornbacher's Wine & Spirits	4265 45 St S Suite 121	B-Limited
Hotel Donaldson	101 Broadway	ABH-RZ
India Palace	5050 13th Ave S Ste #3	GH
Firebox	4554 7 Ave S	A
Izumi Sushi and Hibachi All You Can Ea	5675 26 Ave S, Suite 108-112	F
Izumi Sushi and Hibachi Buffet	5050 13 Ave S Ste 5	F

JL Beers	4240 32 Ave S	AB-M
JL Beers	518 1st Ave N	FA-RZ-M
Johnny Carino's	4410 17 Ave S	FA
Juice It Smoothie	64 Broadway N, Suite 101	F
Kilstone Brewing	764 34 St N, Suite R	Y
Kobe's Japanese Cuisine	4228 15 Ave S	F
La Quinta Inn & Suites	2355 46 St S	ABH-Limited
Labby's Grill & Bar	1100 19 Ave N	Z
Leela Thai Cuisine LLC	1450 25 St S	GH
LongHorn Steakhouse #5432	4410 13th Ave S	FA
Lucky's 13 Pub	4301 17 Ave S	FA
Lucy's North China Cuisine	4323 45 St S Ste 105	F
Luna	1545 University Dr S	FA
Main Liquors	4000 Main Avenue	B
Mangos Mexican & American Grill	2901 Main Ave	F
Marlin's Family Restaurant	3520 12 Ave N	F
Men's Hair World	1801 45 St S Ste L1	C
Mexican Village	814 Main Avenue	F
Mexican Village	3155 45 St S	FA
Mezzaluna	309 Roberts St N	FA-RZ
Nail Deluxe	4302 13 Ave S, Suite 5	G
Nichole's Fine Pastry	13 S 8th St	GH
Nobull Country Club	609 NP Ave	Z
Northport Liquors	2726 North Broadway	B
O'Kellys	3800 Main Avenue	ABH
Old Broadway Food & Brewing Co	22 Broadway N	AB
Old Chicago	2551 45th Street South	FA
Olive Garden Italian Restaurant #1188	4339 13th Avenue SW	FA
Osaka Sushi and Hibachi	1111 38 St S	F
Pancho's Mexican Grill	4761 13 Ave S Ste C	H
Paradiso	801 38th Street South	A
Passage to India	855 45 St S Suite A-3	GH
Pepper's American Cafe	2510 South University Drive	AB
Pho D'Licious	623 NP Ave N	H
Pickled Parrot	505 3 Ave N	AB
Pixeled Brewing Co	1100 NP Ave, Suite 101	Y
Pizza Ranch	4480 23 Ave S Suite A	H
Plains Art Museum	704 1st Avenue North	GH
Porter Creek Hardwood Grill	1555 44 St S	ABH
Pounds	612 1 Ave N	FA-RZ
Prairie Brothers Brewing Company	4474 23 Ave S, Suite 9	Y
Prairie Rose Meadery LLC	3101 39 St S, Suite E	P
Proof Artisan Distillers	414 4 Ave N	DD
Radisson-Fargo	201 5th Street North	ABH
Ramada Hotel & Conference	3333 13th Avenue South	ABH
Red Lobster #309	4215 13th Avenue South	A
Rhombus Guys	606 Main Ave	FA-RZ-M

Rick's Bar	2721 Main Avenue	AB
Rooter's Bar	107 Broadway	AB
Rosey's Bistro	212 Broadway, Suite 103	FA-RZ
Round Up (45th St) Royal Liquors and	14501 Urban Plains Dr S	AB
Royal Liquors & Woody's Bar (32nd Av	1550 32nd Avenue So	AB
Royal Liquors (25th St)	3051 25 St S Unit C	B
Royal Liquors (Main Ave)	1606 Main Avenue	B
Ruby Tuesday	2535 23 Ave S	FA
Sammy's Pizza	301 Broadway	GH
Samurai Japanese Cuisine	1775 45 St S Suite B	GH
Sanctuary Event Center	670 4 Ave N	RZ-V
Select Inn Fargo-Penalty Box	1025 38th Street South	ABH
Shotgun Sally's Rock N Roll Saloon	1515 42 Street South	Z
Sickie's Garage	3431 Fiechtner Dr S	FA
Side Show Café	901 25 St S	H
SideStreet Grille & Pub	404 4 Ave N	A
Sky Dine Services	2801 32 Ave N	A
Slammer's Bar	707 28 Ave N	A
SmashBurger	1801 45 St SW	H
Son's of Norway	722 2nd Avenue North	AC
SouthTown PourHouse	4281 45 St S, Ste 104	FA
Space Aliens Grill & Bar	1840 45th Street SW	FA
Speck's Bar	2611 Main Avenue	AB
Spicy Pie	322 Broadway N Ste A	H
Spicy Pie	2640 52 Ave S	H
Spirit Shop (33 ST)	1404 33 St S	B-M
Sports Bar	619 NP Avenue	AB
Square One	1407 1 Ave N	GH
Stamart Liquor	3220 12 Ave N	B-Limited
Staybridge Suites Hotel	4300 20 Ave S	ABH-Limited
Steve's Package Store	524 4 St N	B
Super Buffet & Mongolian Grill	1000 45 St S Ste 100	GH
Taco's Trompo	4265 45 St S Suite 113	H
Tailgator's/Mom's Kitchen	1322 Main Avenue	AB
Tavern Grill	4504 32 Ave S	FA
Tavern Grill Grotto	3233 45 St S	I
Texas Roadhouse	4971 13 Ave S	FA
The Boiler Room	210 N Broadway Suite 90	FA-RZ
The Bulldog Tap	4265 45 St S Suite 161	Z
The Nail Bar	505 Broadway N	GH
The Northern	325 10th Street North	AB
The Stage at Island Park, Fargo Moorh	333 4th St S	AC
Toasted Frog	305 Broadway N	FA-RZ
Toscana	202 Broadway N	GH
Touchmark	1200 Harwood Drive S	F
Twist	220 Broadway N	FA-RZ
Uncle Maddio's Pizza	1690 45 St S, Suite 2	H

VFW	202 Broadway N	A
Vinyl Taco	520 1 Ave N	FA-RZ
VIP Room & Catering	624 Main Avenue	GH
Wasabi/Poke Bowl	560 2 Ave N	F
West Acres Bowl	3402 Interstate Boulevard SW	AB
Wild Bill's Sports Saloon	1776 45 ST S	FA
Wild Terra Cider and Brewing Compan	6 12 St N	CWP
Windbreak Saloon	3150 39th Street SW	AB
Wingstop	2653 45 St S	H
Wurst Bier Hall	630 1 Ave N Suite 1	FA-RZ-M

5

**CITY OF FARGO
GENERAL FUND - BUDGET TO ACTUAL
THROUGH MAY 2019
(UNAUDITED)**

	2019 BUDGET	2019 ACTUAL	VARIANCE
REVENUES:			
Taxes	\$ 25,786,359	\$ 26,086,293	\$ 299,934
Licenses & Permits	1,623,975	1,690,935	66,960
Fines & Traffic Tickets	745,785	662,730	(83,055)
Intergovernmental Revenue	7,083,314	5,372,189	(1,711,125)
Charges for Services	4,695,698	4,176,238	(519,460)
Interest	1,624,166	1,970,085	345,919
Miscellaneous Revenue	252,398	205,971	(46,427)
Transfers In	7,085,175	5,805,123	(1,280,052)
Total Revenues	\$ 48,896,870	\$ 45,969,564	\$ (2,927,306)
EXPENDITURES:			
City Administrator	\$ 3,385,249	\$ 3,144,526	\$ 240,723
Finance	3,331,915	2,920,215	411,700
Planning & Development	1,556,568	1,360,366	196,202
Transit	3,416,440	3,140,052	276,388
Public Works	6,657,092	7,481,078	(823,986)
Fire Department	6,096,481	5,742,220	354,261
Police	9,039,438	8,685,732	353,706
Health	4,556,251	4,389,849	166,402
Library	1,880,204	1,805,388	74,816
Commission	289,746	278,116	11,630
Civic Center	219,572	218,984	588
Social Services	403,400	278,562	124,838
Capital Outlay	215,580	149,501	66,079
Vehicle Replacement/IT	161,359	126,752	34,607
Contingency	(459,780)	6,534	(466,314)
Transfers Out	2,880,533	3,299,094	(418,561)
Total Expenditures	\$ 43,630,048	\$ 43,026,969	\$ 603,079
Excess of Revenue Over (Under) Expenditures	\$ 5,266,822	\$ 2,942,595	\$ (2,324,227)



GAMING SITE AUTHORIZATION
 OFFICE OF ATTORNEY GENERAL
 SFN 17996 (02/2018)



G - _____ (_____) _____
 Site License Number
 (Attorney General Use Only)

Full, Legal Name of Gaming Organization **SPECIAL OLYMPICS NORTH DAKOTA**

The above organization is hereby authorized to conduct games of chance under the license granted by the Attorney General of the State of North Dakota at the following location

Name of Location ROOTERS BAR			
Street 107 Broadway	City Fargo	ZIP Code 58102	County CASS
Beginning Date(s) Authorized 7/1/19	Ending Date(s) Authorized 6/30/20	Number of twenty-one tables if zero, enter "0": 2	
Specific location where games of chance will be conducted and played at the site (required) Entire Bar except restrooms			
If conducting Raffle or Poker activity provide date(s) or month(s) of event(s) if known			

RESTRICTIONS (City/County Use Only)

Days of week of gaming operations (if restricted)	Hours of gaming (if restricted)
---	---------------------------------

ACTIVITY TO BE CONDUCTED Please check all applicable games to be conducted at site (required)

<input type="checkbox"/> Bingo	<input type="checkbox"/> Club Special	<input type="checkbox"/> Sports Pools
<input type="checkbox"/> ELECTRONIC Quick Shot Bingo	<input type="checkbox"/> Tip Board	<input checked="" type="checkbox"/> Twenty-One
<input type="checkbox"/> Raffles	<input type="checkbox"/> Seal Board	<input type="checkbox"/> Poker
<input type="checkbox"/> ELECTRONIC 50/50 Raffle	<input type="checkbox"/> Punchboard	<input type="checkbox"/> Calcuttas
<input checked="" type="checkbox"/> Pull Tab Jar	<input type="checkbox"/> Prize Board	<input type="checkbox"/> Paddlewheels with Tickets
<input type="checkbox"/> Pull Tab Dispensing Device	<input type="checkbox"/> Prize Board Dispensing Device	<input type="checkbox"/> Paddlewheel Table
<input checked="" type="checkbox"/> ELECTRONIC Pull Tab Device		

APPROVALS

Attorney General	Date
Signature of City/County Official	Date
	6/17/2019
PRINT Name and official position of person signing on behalf of city/county above Steve Sprague/City Auditor	

INSTRUCTIONS:

1. City/County-Retain a **copy** of the Site Authorization for your files.
2. City/County-Return the **original** Site Authorization form to the Organization.
3. Organizations - Send the **original, signed**, Site Authorization to the Office of Attorney General with any other applicable licensing forms for final approval.

RETURN ALL DOCUMENTS TO:

Office of Attorney General
 Licensing Section
 600 E Boulevard Ave, Dept. 125
 Bismarck, ND 58505-0040
 Telephone: 701-328-2329 OR 800-326-9240



GAMING SITE AUTHORIZATION
 OFFICE OF ATTORNEY GENERAL
 SFN 17996 (02/2018)

66

G - _____ (____)____
 Site License Number
 (Attorney General Use Only)

Full, Legal Name of Gaming Organization **Prairie Public Broadcasting, Inc**

The above organization is hereby authorized to conduct games of chance under the license granted by the Attorney General of the State of North Dakota at the following location

Name of Location Peppers			
Street 2510 S University Dr	City Fargo	ZIP Code 58102	County Cass
Beginning Date(s) Authorized 7/1/19	Ending Date(s) Authorized 6/30/20	Number of twenty-one tables if zero, enter "0": 0	
Specific location where games of chance will be conducted and played at the site (required) Entire facility, excluding the restrooms			
If conducting Raffle or Poker activity provide date(s) or month(s) of event(s) if known			

RESTRICTIONS (City/County Use Only)

Days of week of gaming operations (if restricted)	Hours of gaming (if restricted)
---	---------------------------------

ACTIVITY TO BE CONDUCTED Please check all applicable games to be conducted at site (required)

<input type="checkbox"/> Bingo	<input type="checkbox"/> Club Special	<input type="checkbox"/> Sports Pools
<input type="checkbox"/> ELECTRONIC Quick Shot Bingo	<input type="checkbox"/> Tip Board	<input type="checkbox"/> Twenty-One
<input type="checkbox"/> Raffles	<input type="checkbox"/> Seal Board	<input type="checkbox"/> Poker
<input type="checkbox"/> ELECTRONIC 50/50 Raffle	<input type="checkbox"/> Punchboard	<input type="checkbox"/> Calcuttas
<input type="checkbox"/> Pull Tab Jar	<input type="checkbox"/> Prize Board	<input type="checkbox"/> Paddlewheels with Tickets
<input type="checkbox"/> Pull Tab Dispensing Device	<input type="checkbox"/> Prize Board Dispensing Device	<input type="checkbox"/> Paddlewheel Table
<input checked="" type="checkbox"/> ELECTRONIC Pull Tab Device		

APPROVALS

Attorney General	Date
Signature of City/County Official	Date
PRINT Name and official position of person signing on behalf of city/county above Steve Sprague/City Auditor	6/17/2019

INSTRUCTIONS:

1. City/County-Retain a **copy** of the Site Authorization for your files.
2. City/County-Return the **original** Site Authorization form to the Organization.
3. Organizations - Send the **original, signed**, Site Authorization to the Office of Attorney General with any other applicable licensing forms for final approval.

RETURN ALL DOCUMENTS TO:

Office of Attorney General
 Licensing Section
 600 E Boulevard Ave, Dept. 125
 Bismarck, ND 58505-0040
 Telephone: 701-328-2329 OR 800-326-9240



GAMING SITE AUTHORIZATION
 OFFICE OF ATTORNEY GENERAL
 SFN 17996 (02/2018)

G - _____ (____)____ Site License Number (Attorney General Use Only)
--

Full, Legal Name of Gaming Organization Jon Greenley Amvets Post # 7

The above organization is hereby authorized to conduct games of chance under the license granted by the Attorney General of the State of North Dakota at the following location

Name of Location Hi- Ho Burgers & Brews			
Street 3051 25th St S	City Fargo	ZIP Code 58103	County Cass
Beginning Date(s) Authorized 7/1/19	Ending Date(s) Authorized 6/30/20	Number of twenty-one tables if zero, enter "0": 0	
Specific location where games of chance will be conducted and played at the site (required) South Wall - South Addition Bar Side			
If conducting Raffle or Poker activity provide date(s) or month(s) of event(s) if known			

RESTRICTIONS (City/County Use Only)	
Days of week of gaming operations (if restricted)	Hours of gaming (if restricted)

ACTIVITY TO BE CONDUCTED Please check all applicable games to be conducted at site (required)

<input type="checkbox"/> Bingo	<input type="checkbox"/> Club Special	<input type="checkbox"/> Sports Pools
<input type="checkbox"/> ELECTRONIC Quick Shot Bingo	<input type="checkbox"/> Tip Board	<input type="checkbox"/> Twenty-One
<input type="checkbox"/> Raffles	<input type="checkbox"/> Seal Board	<input type="checkbox"/> Poker
<input type="checkbox"/> ELECTRONIC 50/50 Raffle	<input type="checkbox"/> Punchboard	<input type="checkbox"/> Calcuttas
<input type="checkbox"/> Pull Tab Jar	<input type="checkbox"/> Prize Board	<input type="checkbox"/> Paddlewheels with Tickets
<input checked="" type="checkbox"/> Pull Tab Dispensing Device	<input type="checkbox"/> Prize Board Dispensing Device	<input type="checkbox"/> Paddlewheel Table
<input type="checkbox"/> ELECTRONIC Pull Tab Device		

APPROVALS	
Attorney General	Date
Signature of City/County Official	Date
	6/17/2019
PRINT Name and official position of person signing on behalf of city/county above Steve Sprague/City Auditor	

INSTRUCTIONS:

1. City/County-Retain a **copy** of the Site Authorization for your files.
2. City/County-Return the **original** Site Authorization form to the Organization.
3. Organizations - Send the **original, signed**, Site Authorization to the Office of Attorney General with any other applicable licensing forms for final approval.

RETURN ALL DOCUMENTS TO:

Office of Attorney General
 Licensing Section
 600 E Boulevard Ave, Dept. 125
 Bismarck, ND 58505-0040
 Telephone: 701-328-2329 OR 800-326-9240



APPLICATION FOR A LOCAL PERMIT OR CHARITY LOCAL PERMIT
 OFFICE OF ATTORNEY GENERAL
 SFN 9338 (08/2016)

702
 ✓ 7798
 25.00
 5/31/19

Application for: Local Permit * Charity Local Permit (one event per year)

Name of Non-profit Organization El Zagal Shrine - Provost Guard			Date(s) of Activity 5/31/19 to 9/6/19		For a raffle, provide drawing date(s): 9/5/19		
Person Responsible for the Gaming Operation and Disbursement of Net Income Keith D. Lingle			Title Committee Chair		Business Phone Number 701-235-7521		
Business Address 1429 3rd St N			City Fargo		State ND	Zip Code 58102	
Mailing Address (if different)			City		State	Zip Code	
Name of Site Where Game(s) will be Conducted El Zagal Shrine			Site Address				
City Fargo, ND			State ND	Zip Code 58102		County Cass	
Check the Game(s) to be Conducted: * Poker, Twenty-one, and Paddlewheels may be Conducted only by a Charity Local Permit. <input type="checkbox"/> Bingo <input checked="" type="checkbox"/> Raffle <input type="checkbox"/> Raffle Board <input type="checkbox"/> Calendar Raffle <input type="checkbox"/> Sports Pool <input type="checkbox"/> Poker * <input type="checkbox"/> Twenty-one * <input type="checkbox"/> Paddlewheels *							

DESCRIPTION AND RETAIL VALUE OF PRIZES TO BE AWARDED

Game Type	Description of Prize	Retail Value of Prize	Game Type	Description of Prize	Retail Value of Prize
Raffle	Meat	\$500 ⁰⁰			
Raffle	TV, Cash, Gun	\$1000 ⁰⁰			
Raffle	Cash	\$500 ⁰⁰			
Raffle	BarTab	\$250 ⁰⁰			

Total: (Limit \$12,000 per year)
\$2250⁰⁰

Intended uses of gaming proceeds: Provost Guard Operations

Does the organization presently have a state gaming license? No Yes - If "Yes," the organization is not eligible for a local permit or charity local permit and should call the Office of Attorney General at 1-800-326-9240.

Has the organization received a charity local permit from this or another city or county for the fiscal year July 1 through June 30? No Yes - If "Yes," the organization does not qualify for a local permit or charity local permit.

Has the organization received a local permit from this or another city or county for the fiscal year July 1 through June 30? No Yes - If "Yes," indicate the total value of all prizes previously awarded: \$ 5200⁰⁰. This amount is part of the total prize limit of \$12,000 per year.

Signature of Organization's Top Executive Official <i>Keith D. Lingle</i>	Date 5/31/19	Title Committee Chair	Business Phone Number 701-277-8570
--	------------------------	---------------------------------	--



APPLICATION FOR A LOCAL PERMIT OR CHARITY LOCAL PERMIT
 OFFICE OF ATTORNEY GENERAL
 SFN 9338 (08/2016)

76

V10538
 25.00
 5/31/19

Application for: Local Permit * Charity Local Permit (one event per year)

Name of Non-profit Organization Haiti Eye Mission		Date(s) of Activity to 8/5/19	For a raffle, provide drawing date(s): August 5, 2019	
Person Responsible for the Gaming Operation and Disbursement of Net Income Lance K Bergstrom		Title President	Business Phone Number (701) 235-5200	
Business Address 2601 Univ Dr S		City Fargo	State ND	Zip Code 58103
Mailing Address (if different)		City	State	Zip Code
Name of Site Where Game(s) will be Conducted Drawing - Bergstrom Eye & Laser Clinic		Site Address 2601 Univ Dr S		
City Fargo		State ND	Zip Code 58103	County Cass

Check the Game(s) to be Conducted: * Poker, Twenty-one, and Paddlewheels may be Conducted only by a Charity Local Permit.
 Bingo Raffle Raffle Board Calendar Raffle Sports Pool Poker * Twenty-one * Paddlewheels *

DESCRIPTION AND RETAIL VALUE OF PRIZES TO BE AWARDED

Game Type	Description of Prize	Retail Value of Prize		
Raffle	Casino Package	\$125.00		
	Twins Tickets	\$600.00		
	Hotel Stay	\$698.00		
	4 person Golf	\$320.00		
	Cash	\$500.00		
			(Limit \$12,000 per year)	
			Total:	\$ 2,243.00

Intended uses of gaming proceeds: Haiti Eye Mission

Does the organization presently have a state gaming license? No Yes - If "Yes," the organization is not eligible for a local permit or charity local permit and should call the Office of Attorney General at 1-800-326-9240.

Has the organization received a charity local permit from this or another city or county for the fiscal year July 1 through June 30? No Yes - If "Yes," the organization does not qualify for a local permit or charity local permit.

Has the organization received a local permit from this or another city or county for the fiscal year July 1 through June 30? No Yes - If "Yes," indicate the total value of all prizes previously awarded: \$ _____ . This amount is part of the total prize limit of \$12,000 per year.

Signature of Organization's Top Executive Official 	Date 5/31/19	Title President	Business Phone Number 235-5200
--	-----------------	--------------------	-----------------------------------



AMENDED (70) 25.00
5/28/19

APPLICATION FOR A LOCAL PERMIT OR CHARITY LOCAL PERMIT
OFFICE OF ATTORNEY GENERAL
SFN 9338 (08/2016)

Application for: Local Permit * Charity Local Permit (one event per year)

R0049-19

Name of Non-profit Organization River Keepers	Date(s) of Activity to 6/17/2019 8/19/19	For a raffle, provide drawing date(s):	
Person Responsible for the Gaming Operation and Disbursement of Net Income Christine Holland	Title Executive Dir	Business Phone Number (701) 235-2895	
Business Address 120 28th Ave. N., Ste. B.	City Fargo	State ND	Zip Code 58102-1334
Mailing Address (if different)	City	State	Zip Code
Name of Site Where Game(s) will be Conducted Edgewood Golf Course	Site Address 19 Golf Course Rd		
City Fargo	State ND	Zip Code 58102-0000	County Cass
Check the Game(s) to be Conducted: * Poker, Twenty-one, and Paddlewheels may be Conducted only by a Charity Local Permit.			
<input type="checkbox"/> Bingo <input checked="" type="checkbox"/> Raffle <input type="checkbox"/> Raffle Board <input type="checkbox"/> Calendar Raffle <input type="checkbox"/> Sports Pool <input type="checkbox"/> Poker * <input type="checkbox"/> Twenty-one * <input type="checkbox"/> Paddlewheels *			

DESCRIPTION AND RETAIL VALUE OF PRIZES TO BE AWARDED

Game Type	Description of Prize	Retail Value of Prize	Game Type	Description of Prize	Retail Value of Prize
raffle	50/50	\$1,000.00			
Total:					\$ 1,000.00

Intended uses of gaming proceeds: River Keepers educational outreach

Does the organization presently have a state gaming license? No Yes - If "Yes," the organization is not eligible for a local permit or charity local permit and should call the Office of Attorney General at 1-800-326-9240.

Has the organization received a charity local permit from this or another city or county for the fiscal year July 1 through June 30? No Yes - If "Yes," the organization does not qualify for a local permit or charity local permit.

Has the organization received a local permit from this or another city or county for the fiscal year July 1 through June 30? No Yes - If "Yes," indicate the total value of all prizes previously awarded: \$ 1,059.00. This amount is part of the total prize limit of \$12,000 per year.

Signature of Organization's Top Executive Official <i>Mike Holland</i>	Date 5/28/2019	Title Executive Director	Business Phone Number (701) 235-2895
---	--------------------------	------------------------------------	--



APPLICATION FOR A LOCAL PERMIT OR CHARITY LOCAL PERMIT

OFFICE OF ATTORNEY GENERAL
SFN 9338 (08/2016)

CASH
6/7/19

70

Application for: Local Permit * Charity Local Permit (one event per year)

Name of Non-profit Organization <i>Fm A m Rotary Club</i>	Date(s) of Activity <i>9/9/19 to 2/2/20</i>	For a raffle, provide drawing date(s):	
Person Responsible for the Gaming Operation and Disbursement of Net Income <i>Sylvia Lunski</i>	Title <i>Fundraiser Charity</i>	Business Phone Number <i>701-365-4040</i>	
Business Address <i>PO BOX 9359</i>	City <i>Fargo</i>	State <i>ND</i>	Zip Code <i>58103</i>
Mailing Address (if different)	City	State	Zip Code
Name of Site Where Game(s) will be Conducted <i>Delta By Marriott</i>	Site Address <i>1635 42nd St. S.</i>		
City <i>Fargo</i>	State <i>ND</i>	Zip Code <i>58103</i>	County <i>CASS</i>

Check the Game(s) to be Conducted: * Poker, Twenty-one, and Paddlewheels may be Conducted only by a Charity Local Permit.

Bingo
 Raffle
 Raffle Board
 Calendar Raffle
 Sports Pool
 Poker *
 Twenty-one *
 Paddlewheels *

DESCRIPTION AND RETAIL VALUE OF PRIZES TO BE AWARDED

Game Type	Description of Prize	Retail Value of Prize	Game Type	Description of Prize	Retail Value of Prize
<i>Monday night football</i>	<i>17 games pay \$25 you a book and have a chance of winning \$50 each game & \$50 half time of SuperBowl & \$100 final score</i>				
					(Limit \$12,000 per year)
					Total: \$ <i>9800.00</i>

Intended uses of gaming proceeds: *Philanthropic Activities*

Does the organization presently have a state gaming license? No Yes - If "Yes," the organization is not eligible for a local permit or charity local permit and should call the Office of Attorney General at 1-800-326-9240.

Has the organization received a charity local permit from this or another city or county for the fiscal year July 1 through June 30? No Yes - If "Yes," the organization does not qualify for a local permit or charity local permit.

Has the organization received a local permit from this or another city or county for the fiscal year July 1 through June 30? No Yes - If "Yes," indicate the total value of all prizes previously awarded: \$ _____. This amount is part of the total prize limit of \$12,000 per year.

Signature of Organization's Top Executive Official <i>Sylvia Lunski</i>	Date <i>6/6/19</i>	Title	Business Phone Number <i>701-365-4040</i>
--	-----------------------	-------	--

625.00
 ✓ 3183
 6-11-19

7e



APPLICATION FOR A LOCAL PERMIT OR CHARITY LOCAL PERMIT
 OFFICE OF ATTORNEY GENERAL
 SFN 9336 (08/2016)

Application for: Local Permit Charity Local Permit (one event per year)

Name of Non-profit Organization <i>Steve Weidner FM Junior Tour</i>		Date(s) of Activity <i>June 30, July 1, 2019 to 2020</i>		For a raffle, provide drawing date(s):	
Person Responsible for the Gaming Operation and Disbursement of Net Income <i>Shelley Weidner</i>		Title <i>Chairman</i>		Business Phone Number <i>701 237-6746</i>	
Business Address <i>509 26th Ave South</i>		City <i>Fargo</i>		State <i>ND</i>	Zip Code <i>58103</i>
Mailing Address (if different)		City		State	Zip Code
Name of Site Where Game(s) will be Conducted <i>Fargo Country Club</i>		Site Address <i>509 26th Ave. S.</i>			
City <i>Fargo</i>		State <i>ND</i>	Zip Code <i>58103</i>	County <i>CASS</i>	
Check the Game(s) to be Conducted: * Poker, Twenty-one, and Paddlewheels may be Conducted only by a Charity Local Permit.					
<input type="checkbox"/> Bingo <input type="checkbox"/> Raffle <input checked="" type="checkbox"/> Raffle Board <input checked="" type="checkbox"/> Calendar Raffle <input type="checkbox"/> Sports Pool <input type="checkbox"/> Poker * <input type="checkbox"/> Twenty-one * <input type="checkbox"/> Paddlewheels *					

DESCRIPTION AND RETAIL VALUE OF PRIZES TO BE AWARDED

Game Type	Description of Prize	Retail Value of Prize	Game Type	Description of Prize	Retail Value of Prize
Raffle boards	Merchandise Gift Certificates				
(no one prize greater than \$2500.00)		\$10,000			
	cash prize	\$2,000			
(no one prize greater than \$1,000)					
TOTAL OF	16 Events For Period				
	July 1, 2019 - June 30, 2020				
Number of EVENTS DETERMINED BY WEATHER.					
Total:					(Limit \$12,000 per year) \$ 12,000

Intended uses of gaming proceeds: *Promote Junior Golf*

Does the organization presently have a state gaming license? No Yes - If "Yes," the organization is not eligible for a local permit or charity local permit and should call the Office of Attorney General at 1-800-326-9240.

Has the organization received a charity local permit from this or another city or county for the fiscal year July 1 through June 30? No Yes - If "Yes," the organization does not qualify for a local permit or charity local permit.

Has the organization received a local permit from this or another city or county for the fiscal year July 1 through June 30? No Yes - If "Yes," indicate the total value of all prizes previously awarded: \$ _____ This amount is part of the total prize limit of \$12,000 per year.

Signature of Organization's Top Executive Official <i>Shelley Weidner</i>	Date <i>6-11-2019</i>	Title <i>Chairman</i>	Business Phone Number <i>701 237-6746</i>
--	--------------------------	--------------------------	--

PUBLIC WORKS PROJECTS EVALUATION COMMITTEE

8

Type: Utility Box & Bench Wrap Agreement Amendment

Location: Downtown Fargo

Date of Hearing: 6/10/2019

<u>Routing</u>	<u>Date</u>
City Commission	6/17/2019
PWPEC File	X
Project File	Kristy Schmidt
	Maegin Elshaug

The Committee reviewed a communication from Civil Engineer, Kristy Schmidt, regarding an amendment to the Art Wrap Agreement approved in April 2018.

The Engineering Department has reviewed the request and is recommending approval of the installation. Chris Schlepp, with the Fargo BID, is proposing to wrap six existing downtown utility boxes and five benches with art submitted by local artists. The Fargo Arts and Culture Commission granted \$2,750 towards the project on April 17, 2019. The Arts and Culture Commission will have final review and approval of the art. The amendment also provides the City Engineer or designee to review and approve additional projects on City owned structures.

On a motion by Tim Mahoney, seconded by Nicole Crutchfield, the Committee voted to recommend approval of the amendment to the Art Wrap Agreement.

RECOMMENDED MOTION

Concur with PWPEC recommendation and approve the amendment to the Art Wrap Agreement.

PROJECT FINANCING INFORMATION:

Recommended source of funding for project: N/A

	Yes	No
Developer meets City policy for payment of delinquent specials		N/A
Agreement for payment of specials required of developer		N/A
Letter of Credit required (per policy approved 5-28-13)		N/A

COMMITTEE

	Present	Yes	No	Unanimous
Tim Mahoney, Mayor	<input checked="" type="checkbox"/>	<input checked="" type="checkbox"/>	<input type="checkbox"/>	<input checked="" type="checkbox"/>
Nicole Crutchfield, Director of Planning	<input checked="" type="checkbox"/>	<input checked="" type="checkbox"/>	<input type="checkbox"/>	
Steve Dirksen, Fire Chief	<input checked="" type="checkbox"/>	<input checked="" type="checkbox"/>	<input type="checkbox"/>	
Bruce Grubb, City Administrator	<input checked="" type="checkbox"/>	<input checked="" type="checkbox"/>	<input type="checkbox"/>	
Ben Dow, Director of Operations	<input type="checkbox"/>	<input type="checkbox"/>	<input type="checkbox"/>	
Steve Sprague, City Auditor	<input type="checkbox"/>	<input type="checkbox"/>	<input type="checkbox"/>	
Brenda Derrig, City Engineer	<input checked="" type="checkbox"/>	<input checked="" type="checkbox"/>	<input type="checkbox"/>	
Kent Costin, Finance Director	<input checked="" type="checkbox"/>	<input checked="" type="checkbox"/>	<input type="checkbox"/>	

ATTEST:

C: Kristi Olson

 Brenda E. Derrig, PE
 City Engineer

Memorandum

To: Members of PWPEC
From: Kristy Schmidt, Civil Engineer
Maegin Elshaug, Planning Coordinator
Date: June 5, 2019
Re: Utility Box and Bench Wrap Proposal

Background:

Chris Schlepp, with the Fargo Business Improvement District (BID), is proposing to wrap six existing downtown utility boxes and five benches with art submitted by local artists. The Downtown Community Partnership (DCP) and the BID did a similar project in 2018, where seven utility boxes were wrapped.

Consistent with the previous project, the artwork will be printed on a vinyl wrap, which allows for the wraps to be easily installed and uninstalled when needed. While repair work may require reprinted pieces from the installer, BID will be responsible for general cleaning and maintenance.

The placement of the wraps on City owned structures was facilitated through an Agreement approved by the City Commission in April 2018. Attached is an Amendment to the Agreement to accommodate the current proposal. The Amendment also provides the City Engineer or designee to review and approve additional projects on City owned structures. The Agreement is for a six-year term.

The Fargo Arts and Culture Commission granted \$2,750.00 towards the project on April 17, 2019. The Arts and Culture Commission will have final review and approval of the art.

Recommended Motion:

We recommend approval to amend the existing Agreement to 1) accommodate the installation of the artwork wrap on six utility boxes and five benches downtown, and 2) provide the City Engineer or designee to review and approve additional similar projects on City owned structures.

KLS/klb
Attachment

AMENDMENT TO ART WRAP AGREEMENT

THIS FIRST AMENDMENT (the "Amendment), dated as of the 3 day of June, 2019, amends that Art Wrap Attachment Agreement for Placement on City Owned Structures in the Public Right of Way dated April 9, 2018 by and between the City of Fargo, North Dakota, with its principal offices located at 225 4th Street North, Fargo, North Dakota 58102, hereinafter designated "City" and the Downtown Community Partnership BID, a North Dakota non-profit corporation with its principal offices located _____ Fargo, North Dakota, 58102, hereinafter designated as "BID."

207 4th St N Suite B

WHEREAS, the Art Wrap Attachment Agreement contemplated the addition of more Utility Boxes:

WHEREAS, City and BID acknowledge that they will make part of this Agreement a site map, which may be amended from time to time, identifying the City Owned Structures on which the art wraps may be installed.

WHEREAS, BID now seeks to wrap additional Utility Boxes, as was contemplated by the Agreement; and

WHEREAS, City is in favor of extending the Utility Box Wrap Proposal to additional City structures, including but not limited to benches, pedestals owned by the City, and other similar City owned structures in the ROW, as was contemplated by the Agreement.

NOW, THEREFORE, in consideration of the mutual covenants herein, the parties agree as follows:

1. BID may amend its site location map to identify additional City Owned Structures for purposes of placing art wraps in the City right of way.
2. Each site must be reviewed in accordance with the terms of the agreement Amended herein, and approved by City Engineer or designee prior to placement on the City Owned Structure.
3. All other terms and conditions of the Art Wrap Attachment Agreement shall remain in full force and effect, unless otherwise modified in writing signed by both parties.

Downtown Community Partnership BID, a
North Dakota 501(c)(3) Non-Profit
Corporation



By: Melissa Rademacher

Its: President

City of Fargo, a North Dakota Municipal
Corporation

Dr. Timothy J. Mahoney, M.D., Mayor

ATTEST:

Steve Sprague, City Auditor



Pedestrian Bench Wrap Proposal

Submitted to:
Arts & Culture Commission

Submitted by:
Chris Schlepp (BID Ops Manager)

Proposal to the Fargo Arts & Culture Commission

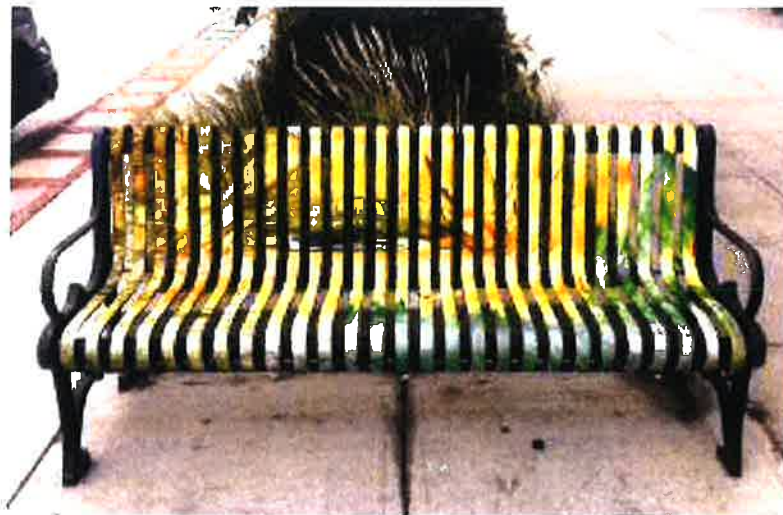

The artists will retain copyright ownership of the original piece but would agree that images of their installed work may be used for promotional and education purposes. Details specifying responsibilities in the event an electrical box becomes damaged to the extent that the artwork must be replaced have not yet been discussed.

PROPOSED STEPS & TIMELINE:

PHASE 1:

Step 1: BID & DCP identify five possible pedestrian benches for wrapping consideration.

Step 2: BID submits recommendations to the City of Fargo for consideration.

Step 3: Fundraise for project sponsors (if applicable).

PHASE 2:

Step 4: Promotion begins and the Call for Art is announced; deadline for entries is **TBD**.

Step 5: Applications reviewed for completeness by the public art sub-committee.

Step 6: Approved artwork is submitted to a graphic artist to ensure artwork meets required specifications NLT **TBD**.

PHASE 3:

Step 7: Installation of designs onto benches NLT **TBD**.

Step 8: DCP drafts and submits press release for public awareness.

Step 9: Artists receive compensation for approved submitted artwork.

FACTORS FOR CONSIDERATION:

Maintenance: While repair work may require reprinted pieces from the installer, the BID will be responsible for general cleaning and maintenance.

Administration: Our committee will function as the contracted administrator for this process.

Sponsors: To be determined, if applicable.

Pedestrian Bench Art Wrap Locations

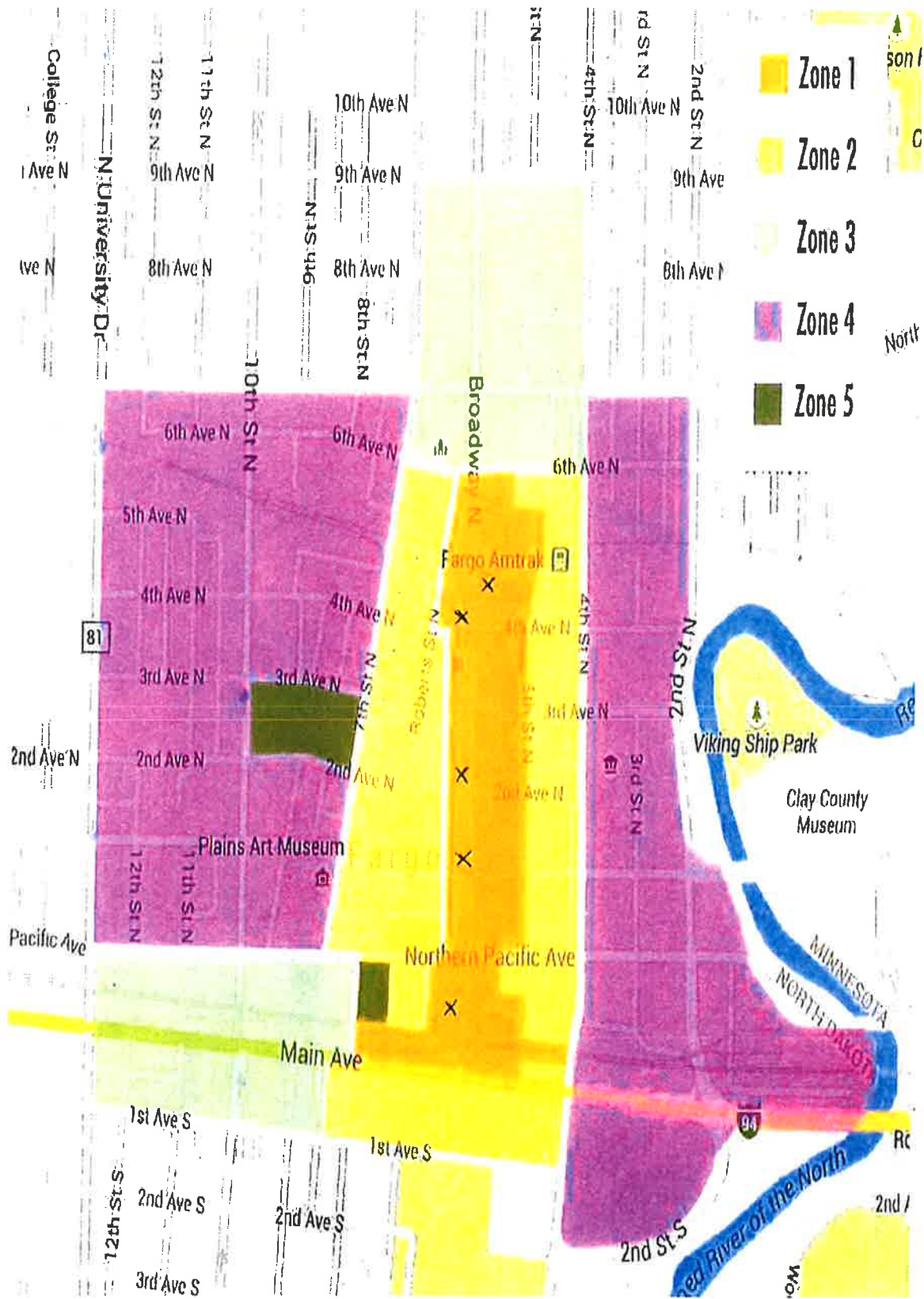

X- Proposed



Utility Box Wrap Proposal

Submitted to:
Arts & Culture Commission

Submitted by:
Chris Schlepp (BID Ops Manager)

Proposal to the Fargo Arts & Culture Commission



The artists will retain copyright ownership of the original piece but would agree that images of their installed work may be used for promotional and education purposes. Details specifying responsibilities in the event an electrical box becomes damaged to the extent that the artwork must be replaced have not yet been discussed.

PROPOSED STEPS & TIMELINE:

PHASE 1:

Step 1: BID & DCP identify six possible utility boxes for wrapping consideration.

Step 2: BID submits utility box recommendations to the City of Fargo for consideration.

Step 3: Fundraise for project sponsors (if applicable).

PHASE 2:

Step 4: Promotion begins and the Call for Art is announced; deadline for entries is **TBD**.

Step 5: Applications reviewed for completeness by the public art sub-committee.

Step 6: Approved artwork is submitted to a graphic artist to ensure artwork meets required specifications NLT **TBD**.

PHASE 3:

Step 7: Installation of designs onto utility boxes NLT **TBD**.

Step 8: DCP drafts and submits press release for public awareness.

Step 9: Artists receive compensation for approved submitted artwork.

FACTORS FOR CONSIDERATION:

Maintenance: While repair work may require reprinted pieces from the installer, the BID will be responsible for general cleaning and maintenance.

Administration: Our committee will function as the contracted administrator for this process.

Sponsors: To be determined, if applicable.

Downtown Utility Box Locations

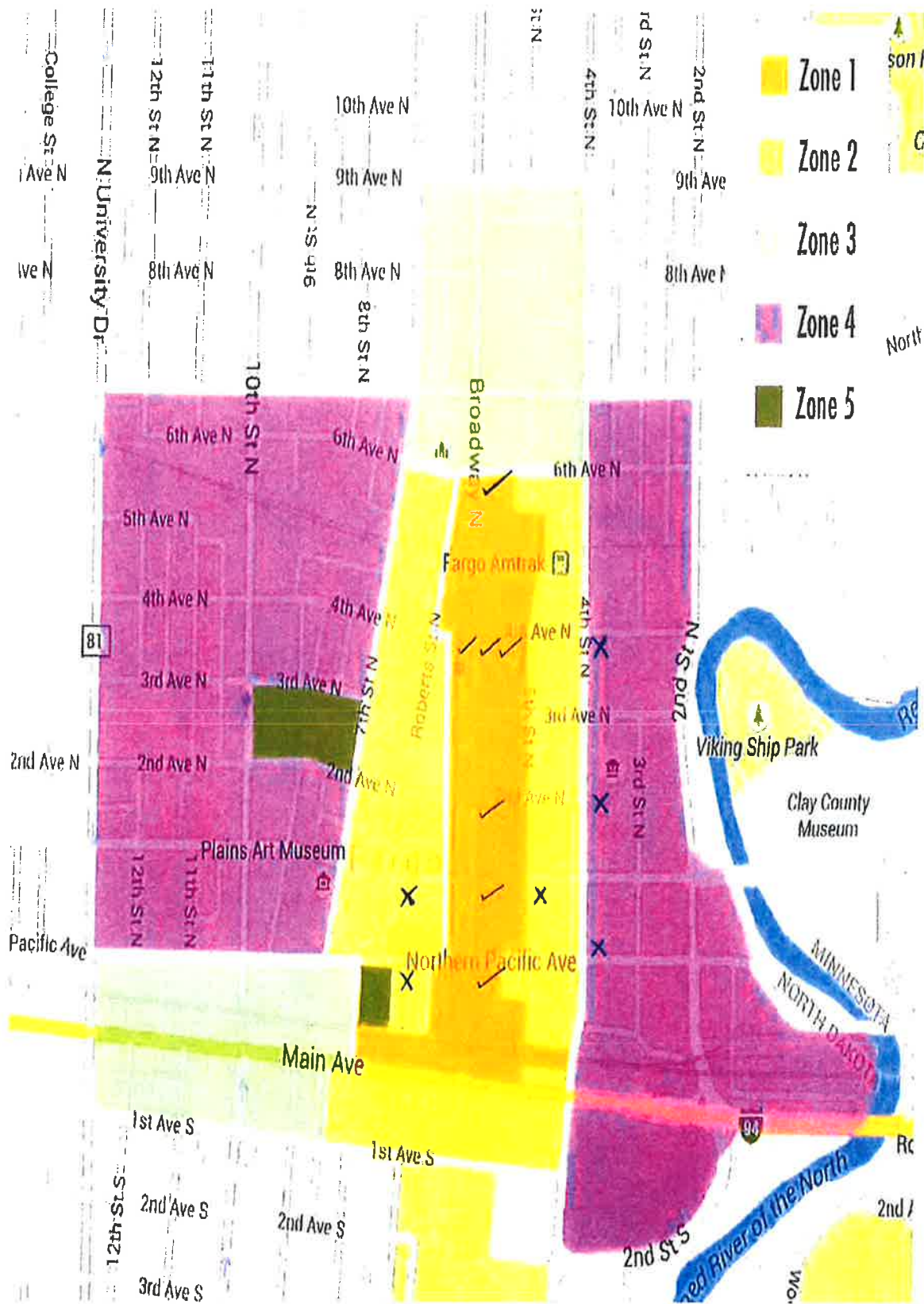

✓ - Existing
X - Proposed

9

REPORT OF ACTION

PUBLIC WORKS PROJECTS EVALUATION COMMITTEE

Type: Release of Negative Access Easement

Location: Lot 2, Block 1, Sincebaugh Addition Date of Hearing: 6/10/2019

<u>Routing</u>	<u>Date</u>
City Commission	<u>06/17/2019</u>
PWPEC File	<u>X</u>
Project File	<u>Kristy Schmidt</u>

The Committee reviewed communication from Civil Engineer, Kristy Schmidt, regarding a Release of Negative Access Easement along 37th Avenue S in Sincebaugh Addition for a back yard shed.

Staff is recommending approval.

On a motion by Tim Mahoney, seconded by Bruce Grubb, the Committee voted to recommend approval of the Release of Negative Access Easement.

RECOMMENDED MOTION

Concur with the recommendations of PWPEC and approve the Release of Negative Access Easement.

PROJECT FINANCING INFORMATION:

Recommended source of funding for project: N/A

Developer meets City policy for payment of delinquent specials
 Agreement for payment of specials required of developer
 Letter of Credit required (per policy approved 5-28-13)

<u>Yes</u>	<u>No</u>
<u>N/A</u>	<u>N/A</u>
<u>N/A</u>	<u>N/A</u>

COMMITTEE

Tim Mahoney, Mayor
 Nichole Crutchfield, Director of Planning
 Steve Dirksen, Fire Chief
 Bruce Grubb, City Administrator
 Ben Dow, Director of Operations
 Steve Sprague, City Auditor
 Brenda Derrig, City Engineer
 Kent Costin, Finance Director

<u>Present</u>	<u>Yes</u>	<u>No</u>	<u>Unanimous</u>
<input checked="" type="checkbox"/>	<input checked="" type="checkbox"/>	<input type="checkbox"/>	<input checked="" type="checkbox"/>
<input checked="" type="checkbox"/>	<input checked="" type="checkbox"/>	<input type="checkbox"/>	
<input checked="" type="checkbox"/>	<input checked="" type="checkbox"/>	<input type="checkbox"/>	
<input checked="" type="checkbox"/>	<input checked="" type="checkbox"/>	<input type="checkbox"/>	
<input type="checkbox"/>	<input type="checkbox"/>	<input type="checkbox"/>	
<input type="checkbox"/>	<input type="checkbox"/>	<input type="checkbox"/>	
<input checked="" type="checkbox"/>	<input checked="" type="checkbox"/>	<input type="checkbox"/>	
<input checked="" type="checkbox"/>	<input checked="" type="checkbox"/>	<input type="checkbox"/>	

ATTEST:

 Brenda E. Derrig, PE
 City Engineer

Memorandum

To: Members of PWPEC
From: Kristy Schmidt, Civil Engineer II
Date: June 5, 2019
Re: Sincebaugh – Release of Negative Access Easement

Background:

An Access has been established to a back yard shed along 37th Avenue South in the Sincebaugh Addition. Staff has reviewed this Access and is supportive of the Release of Negative Access Easement at Lot 2, Block 1 of Sincebaugh Addition.

Attached is a Release of Negative Access Easement for your approval.

Recommended Motion:

Approve the Release of Negative Access Easement at Lot 2, Block 1 of Sincebaugh Addition.

KLS/klb
Attachment

C: Brenda Derrig, City Engineer

Release of Negative Access Easement

On March 28, 2003, document #1050441 identified a negative access easement in favor of the **City of Fargo**, a North Dakota municipal corporation (“Grantee”), restricting access for the purpose of ingress, egress and utilities, to those properties situated in the plat with access provided by other means.

Grantee hereby consents to, and does hereby release, any and all interest of the City in the Negative Access Easement for the following described premises:

The east 20’ of the south property line of Lot 2, Block 1 of Sincebaugh Addition to the City of Fargo, County of Cass, State of North Dakota.

IN WITNESS WHEREOF, Grantee has set its hand and caused this instrument to be executed this ____ day of _____, 2019.

CITY OF FARGO, a North Dakota
a municipal corporation,

Timothy J. Mahoney, M.D., Mayor

ATTEST:

Steven Sprague, City Auditor

STATE OF NORTH DAKOTA)
) ss.
COUNTY OF CASS)

On this ____ day of _____, 2019, before me, a notary public in and for said county and state, personally appeared **Timothy J. Mahoney, M.D.**, and **Steven Sprague**, to me known to be the Mayor and City Auditor, respectively, of the City of Fargo, a North Dakota municipal corporation, described in and that executed the within and foregoing instrument, and acknowledged that said municipal corporation executed the same.

(SEAL)

Notary Public
Cass County, ND

The legal description was obtained from a previously recorded document.

This document was prepared by:
Nancy J. Morris
Assistant City Attorney
Erik R. Johnson & Associates, Ltd.
505 Broadway N., Ste. 206
Fargo, ND 58102
(701) 280-1901
nmorris@lawfargo.com

10

June 12, 2019

Honorable Board of City
Commissioners
City of Fargo
Fargo, ND

Re: Project No. PR-19-C1

Dear Commissioners:

Bids were opened at 11:30 AM on Wednesday, June 12, 2019, for Concrete Pavement Rehabilitation & Incidentals, Project No. PR-19-C1, located at 42nd Street South from 19th Avenue South to 32nd Avenue South.

The bids were as follows:

Dakota Underground Co. \$2,282,453.00

Engineer's Estimate \$1,815,653.40

The special assessment escrow is not required.

This office recommends award of the contract to Dakota Underground Co. in the amount of \$2,282,453.00 as the lowest and best bid.

Sincerely,



Tom Knakmuhs
Assistant City Engineer

TAK/klb

ENGINEER'S STATEMENT OF ESTIMATED COST**PROJECT # PR-19-C1****Concrete Pavement Rehabilitation & Incidentals**

42nd Street S from 19th Ave S to 32nd Ave S

WHEREAS, bids have been opened and filed for the above described Project for City of Fargo, North Dakota; and WHEREAS, an estimate of the cost of work is required by the engineer for the City of Fargo, North Dakota;

NOW THEREFORE Tom Knakmuhs, do hereby certify as follows:

That I am the Assistant City Engineer for the City of Fargo, North Dakota;

That the following is detailed statement of the estimated cost of the job described as:

Concrete Pavement Rehabilitation & Incidentals Project # PR-19-C1 of the City of Fargo, North Dakota.

Line Description	Unit	Quantity	Unit Price (\$)	Amount (\$)
Paving				
1 Temp Fence - Safety	LF	600.00	5.00	3,000.00
2 Remove Pavement All Thicknesses All Types	SY	1,500.00	20.00	30,000.00
3 Adjust Manhole	EA	1.00	1,000.00	1,000.00
4 Repair Inlet	EA	8.00	3,000.00	24,000.00
5 Modify Inlet Type A	EA	6.00	1,500.00	9,000.00
6 Modify Inlet Type B	EA	4.00	2,500.00	10,000.00
7 F&I Geogrid - Subgrade Reinf	SY	4,000.00	8.00	32,000.00
8 Rem & Repl Curb & Gutter	LF	3,300.00	48.00	158,400.00
9 Repair Pavement - Partial Depth Conc	SF	500.00	100.00	50,000.00
10 Rem & Repl Pavement 10" Thick Doweled Conc	SY	5,700.00	155.00	883,500.00
11 F&I Median Nose - Conc	SY	40.00	300.00	12,000.00
12 F&I Sidewalk Curb	LF	40.00	45.00	1,800.00
13 F&I Sidewalk 4" Thick Reinf Conc	SY	1,650.00	55.00	90,750.00
14 F&I Sidewalk 6" Thick Reinf Conc	SY	210.00	60.00	12,600.00
15 Remove Sidewalk All Thicknesses All Types	SY	2,280.00	16.00	36,480.00
16 F&I Impressioned 6" Thick Reinf Conc	SY	500.00	100.00	50,000.00
17 F&I Det Warn Panels Cast Iron	SF	350.00	60.00	21,000.00
18 F&I Casting - Inlet	EA	9.00	1,800.00	16,200.00
19 F&I Casting - Std Manhole	EA	4.00	620.00	2,480.00
20 F&I Casting - Floating Manhole	EA	9.00	1,720.00	15,480.00
21 Casting to Grade - w/Conc	EA	32.00	800.00	25,600.00
22 GV Box to Grade - w/Conc	EA	5.00	600.00	3,000.00
23 Repair Pavement - Patch Asph	SY	40.00	175.00	7,000.00
24 F&I Aggregate for Asph Pavement FAA 43	TON	900.00	56.00	50,400.00
25 F&I Asphalt Cement PG 58-34	GAL	12,558.00	2.50	31,395.00
26 F&I Traffic Surface Gravel	TON	2,300.00	30.00	69,000.00
27 Mill / Grind Conc Pvmt	SY	11,000.00	10.00	110,000.00
28 Topsoil - Import	CY	600.00	40.00	24,000.00
29 Mulching Type 1 - Hydro	SY	4,500.00	1.10	4,950.00
30 Seeding Type B	SY	4,500.00	1.10	4,950.00
31 F&I Erosion Control Blanket Type 3	SY	1,400.00	2.80	3,920.00
32 Inlet Protection - Existing Inlet	EA	22.00	200.00	4,400.00
33 Stormwater Management	LS	1.00	3,000.00	3,000.00
34 Construction Signing	SF	120.00	57.20	6,864.00
35 Flagging	MHR	1,400.00	50.00	70,000.00
36 Traffic Control - Type 2	LS	1.00	253,760.00	253,760.00
37 Relocate Sign Assembly	EA	10.00	150.00	1,500.00
38 F&I Rock Muich	TON	15.00	200.00	3,000.00
39 F&I W-Beam Guardrail	LF	180.00	76.00	13,680.00
40 F&I W-Beam Guardrail End Terminal	EA	2.00	1,650.00	3,300.00
41 Remove W-Beam Guardrail & Posts	LF	180.00	10.00	1,800.00

ENGINEER'S STATEMENT OF ESTIMATED COST

PROJECT # PR-19-C1

Concrete Pavement Rehabilitation & Incidentals

42 F&I Jersey Barrier	LF	20.00	400.00	8,000.00
			Paving Total	2,163,209.00
Pavement Markings				
43 F&I Grooved Plastic Film 4" Wide	LF	400.00	9.90	3,960.00
44 F&I Grooved Plastic Film 8" Wide	LF	800.00	16.50	13,200.00
45 F&I Grooved Plastic Film 16" Wide	LF	80.00	31.00	2,480.00
46 F&I Grooved Plastic Film 24" Wide	LF	280.00	39.60	11,088.00
47 F&I Grooved Contrast Film 7" Wide	LF	800.00	15.40	12,320.00
48 F&I Grooved Plastic Film Message	SF	350.00	39.60	13,860.00
49 Obliterate Pavement Markings	SF	500.00	5.50	2,750.00
50 Paint Epoxy Message	SF	600.00	18.70	11,220.00
51 F&I Methacrylate 6" Wide	LF	72.00	42.00	3,024.00
52 F&I Methacrylate 16" Wide	LF	36.00	72.00	2,592.00
			Pavement Markings Total	76,494.00
Street Lighting				
53 F&I Luminaire Type A	EA	17.00	1,050.00	17,850.00
54 F&I Luminaire Type B	EA	5.00	1,000.00	5,000.00
			Street Lighting Total	22,850.00
Traffic Signals				
55 F&I Detection In-Ground Loop	EA	4.00	2,500.00	10,000.00
56 F&I Detection Preformed Loop	EA	11.00	900.00	9,900.00
			Traffic Signals Total	19,900.00
			Total Construction in \$	2,282,453.00
			Engineering	6.00 % 136,947.18
			Legal & Misc	3.00 % 68,473.59
			Contingencies	10.00 % 228,245.30
			Interest	4.00 % 91,298.12
			Total Estimated Costs	2,807,417.19
			Sales Tax Funds - Infrastructure - 420	2,807,417.19
			Unfunded Costs	0.00

IN WITNESS THEREOF, I have hereunto set my hand and seal

Date: 06/12/2019



Tom Knakmuhs

Assistant City Engineer





(11)

Fargo City Commission
225 4th Street North
Fargo, ND 58102

Commissioners:

The Fargo Dome Authority requests your approval of the piggyback procurement of using AVI Systems, Inc. to replace the arena public address sound system at FARGODOME. AVI Systems, Inc. is part of the state contract #110 STAGEnet Network Equipment / Audio / Visual / Video. They have provided a contract to replace all speakers, amplifiers and subwoofers for the arena. AVI Systems is using the agreed upon labor rates quoted in the state contract, along with providing a substantial discount on the Bose equipment being installed. The state contract calls for a minimum discount of 14% off of the list price, however AVI Systems is giving a 42% discount off of the listed price.

The Fargo Dome Authority has a \$250,000 line item already included, and approved, in the 2019 FARGODOME Capital Budget for this work. At their meeting on Tuesday, May 28, 2019, the Fargo Dome Authority also unanimously approved a motion to re-allocate an additional \$257,309 of funds in the existing 2019 FARGODOME Capital Budget and carryover projects to fully fund the total project cost of \$501,104.46 using existing budgeted, and approved, FARGODOME capital budget funding.

The City of Fargo Finance Committee, at their June 6, 2019 meeting, also reviewed, and approved, this request. The Report of Action from the City of Fargo Finance Committee is attached for reference.

Requested Motion: To approve the piggyback procurement request to contract with AVI Systems, Inc. to perform the work to replace the FARGODOME arena public address sound system through the State of North Dakota contract #110 – STAGEnet Network Equipment / Audio / Visual / Video.

Thank you for your consideration of this matter.

Very truly yours,

Rob Sobolik
General Manager, FARGODOME

City of Fargo Finance Committee Meeting

Report of Action

Meeting Date: June 6, 2019

Item Description: Sole Source Procurement for FargoDome Sound System Updates

Rob Sobolik presented a sole source procurement request to update the public address sound system at the FargoDome. This project includes replacement of speakers, amplifiers and subwoofers for the arena. He reported that AVI is the vendor recommended and that his request was a piggyback contract from the State of North Dakota bid listing. This work has been budgeted in the 2019 capital outlay plan for the Dome.

AVI installed the initial system in 2006 and are familiar with the existing configuration and will re-use cabling and software to run the system. The project cost is estimated at \$501,104.

Motion by: Piepkorn

Second by: Grubb

Vote: Yes No Absent

Mahoney x

Piepkorn x

Grubb x

Redlinger x

Sprague x

Costin x



Sole Source and Piggyback Procurement Form

Sole Source and Piggyback Justification for Procurement

The following information is offered for the sole source acquisition of goods or services described below. The purchase has been thoroughly researched and it has been determined that the vendor/brand is the only acceptable vendor/brand for the product or services that will fit the particular need.

Vendor Name:

AVI Systems Inc.

Estimated Dollar Amount of Purchase:

\$501,104.46

The project/service is required to:

Description of features or capabilities unique to the vendor/brand being requested as related to project requirements:

AVI installed the existing public address sound system when it was redone in 2006. They are the most familiar with the system and are able to re-use all of the cabling and the software used to run the system.

Provide a brief description of how your investigation was conducted. (Internet, publications, consultations) List all sources identified and investigated to determine that no other source exists for similar products capable of meeting requirements (Must be exhaustive of all sources for the commodity being purchased. **)

Using a Piggyback purchase utilizing the existing state agreement "STAGEnet Network Equipment / Audio / Visual / Video", contract #110 with State of North Dakota that AVI, Inc currently has in place. This was same contract used for completion of the audio/visual needs of the commission chambers with the completion of Fargo City Hall.

****If all sources are not investigated a competitive solicitation must be issued.**

Provide a side-by-side comparison of the features/service of all other vendors/brands considered. (List the features or capabilities required for your project and how each vendor investigated does or does not meet those requirements. A table format is recommended)

N/A

If the piggyback procurement method is being used, please provide a copy of the piggyback contract.

See Attached contract reference, contract amendment #1 for AVI Systems, Inc., professional services pricing, and the video conferencing equipment, software and maintenance documentation. Through the video conferencing discounting with AVI Systems, we would receive a minimum of 14% off the list price of products, however I have an email from AVI representatives stating we are receiving 42% off of the list price for Bose equipment, that email also attached.

Signature: 
(Requestor)

Printed Name: Rob Sobolik

Department: Fargodome

Title: General Manager

Date: May 29, 2019

I, hereby, certify that this justification for other than full and open competition is accurate and complete to the best of my knowledge and belief.

 (Requestor initials)

Retail Sales Agreement



AVI Systems Inc., 1930 E Century Ave Bismarck, ND, 58503-0640 | Phone: (701)258-6360, Fax: (701)258-2015

Proposal Number: 949473
 Prepared For: Fargodome
 Attn: Rob Sobolik

Proposal Date: May 28, 2019

Complete System

Prepared By: Kathy Skramstad
 Phone: (701)323-3064
 Email: Kathy.Skramstad@avisystems.com

BILL TO

Attn: Rob Sobolik
 Fargodome
 1800 N. University Drive
 Fargo, ND, 58102
 Phone: (701)241-9100
 Email: rsobolik@fargodome.com
 Customer Number: 27417

SITE

Attn: Rob Sobolik
 Fargodome
 1800 N. University Drive
 Fargo, ND, 58102
 Phone: (701)241-9100
 Email: rsobolik@fargodome.com

COMMENTS

PRODUCTS AND SERVICES SUMMARY

Equipment	\$338,410.46
Integration	\$153,912.00
PRO Support	\$0.00
Shipping & Handling	\$8,782.00
Tax	\$0.00
Grand Total	\$501,104.46

Unless otherwise specified. The prices quoted reflect a discount for a cash payment (i.e., check, wire transfer) made by Customer in full within the time stated for payment on each invoice. Discount only applies to new items included on the invoice, and only applies if the balance on the invoice is paid in full.

All returned equipment is subject to a restocking charge. The prices are valid for 30 days and may be locked in by signing this Retail Sales Agreement.

Overdue balances are subject to a finance charge of 1.5% per month, or interest at the highest rate permitted by applicable law. In the event AVI must pursue collection of unpaid invoices, Customer agrees to pay all of AVI's costs of collection, including its attorneys' fees.

INVOICING AND PAYMENT TERMS

Customer and AVI have agreed on the payment method of ON ACCOUNT. Payment must be remitted by stated method. To the extent Customer seeks to use of any payment methods other than stated, and that payment method results in an increased transaction cost to AVI, the new payment must be approved in writing, and the Customer shall be responsible for paying the increased transaction cost to AVI associated with the change in payment method. Payments shall be made 30 days from invoice date. So long as the invoice has been sent and the Customer's payment is made within the terms work will continue.

AVI will invoice per the estimated payment schedule noted below, subject to modification due to executed change orders. Unless otherwise specified, all items quoted (goods and services) as well as applicable out of pocket expenses (permits, licenses, etc.) are invoiced in summary.

Estimated Payment 1	\$200,441.78	40% Total Project Estimate Deposit, Due on Signature - No Tax Collected
Estimated Payment 2	\$200,441.78	80% Total Project Estimate (including any change orders) Paid by/Due on Equipment Delivery (plus tax on Payment 1 and 2)
Estimated Payment 3	\$100,220.89	Remaining 20% Total - On AVI Notice of substantial completion of original job as bid

Customer is to make payments to the following "Remit to" address:

AVI Systems
 NW8393 PO Box 1450
 Minneapolis, MN 55485-8393

If Payment Method is ACH: Customer must make all payments in the form of bank wire transfers or electronic funds transfers through an automated clearinghouse with electronic remittance detail, in accordance with the payment instructions AVI Systems provides on its invoice to Customer.

A monthly summary of detailed equipment received is available upon request. Equipment received may be different than equipment billed based on agreed billing method.

TAXES AND DELIVERY

Unless stated otherwise in the "Products and Services Summary" above, AVI will add and include all applicable taxes, permit fees, license fees, and delivery charges to the amount of each invoice. Taxes will be calculated according to the state law(s) in which the product(s) and/or service(s) are provided. Unless Customer provides a valid tax exemption certificate for any tax exemption(s) claimed, AVI shall invoice for and collect all applicable taxes in accordance with state law(s), and Customer will be responsible for seeking a tax credit/refund from the applicable taxing authority.

AGREEMENT TO QUOTE AND DOCUMENTS CONSTITUTING YOUR CONTRACT WITH AVI

Customer hereby accepts the above quote for goods and/or services from AVI. When duly executed and returned to AVI, AVI's Credit Department will check Customer's credit and approve the terms. After approval by AVI's Credit Department and signature by AVI, this Retail Sales Agreement will, together with the AVI General Terms & Conditions form a binding agreement between Customer and AVI. (This Retail Sales Agreement and the AVI General Terms & Conditions of Sale (the "T&Cs") are referred to collectively as the "Agreement"). If not defined in this Agreement, all capitalized terms shall have the meaning given to them in the T&Cs. Should AVI's

Credit Department determine at any point prior to AVI commencing work that Customer's credit is not adequate, or should it otherwise disapprove of the commercial terms, AVI reserves the right to terminate the Agreement without cause and without penalty to AVI.

AGREED AND ACCEPTED BY

Company

Signature

Printed Name

Date

AVI Systems, Inc.

Company
Kathy Skramstad

Signature
Kathy Skramstad

Printed Name
06/11/2019

Date

SERVICES TO BE PROVIDED

INTEGRATION SERVICES

In developing a comprehensive proposal for equipment and integration services AVI Systems' Sales Representatives and Engineering teams must make some assumptions regarding the physical construction of your facility, the availability of technical infrastructure and site conditions for installation. If any of the conditions we have indicated in the site survey form are incorrect or have changed for your project or project site, please let your Sales representative know as soon as possible. Conditions of the site found during integration effort which are different from those documented may influence the price of the system solution, integration or services. To ensure that you have an accurate proposal based on your facility and specific to the conditions of your project, please review all project documentation carefully.

INTEGRATION SCOPE OF WORK

1. SUMMARY:

- Remove all existing bowl speakers.
- Hand off existing speakers to owner for disposal.
- FargoDome will provide boom lift capable of reaching all speaker locations
- Install new Bose arena match speaker system.
- Reuse existing rigging.
- All rigging will be inspected and replaced if not serviceable.
- Adjust and commission system. Bose staff will be on site during commissioning to guaranty perform.
- New system average SPL is 100.5 db.
- All material in stock and complete system would be installed and commissioned before 8/01/2019.
- Savings for commissioning, and engineering time if amplifier and speaker package installed at same time.

Amplifiers and Subwoofers

- Remove add Bowl amplifiers from equipment racks on cat walk.
- Lower existing amplifiers and hand off to owner for recycling.
- Install 24 new Bose power match amplifiers.
- Connect amplifiers to existing cabling and DSP's.
- Connect amplifiers to existing network ports in rack for monitoring.
- Build Bose DSP file to amplifier monitoring.
- Test all existing speakers and note damaged or failed drivers.
- Adjust existing DSP file for new amplifiers.
- Test and Balance Bowl sound system.
- Train staff on Bose amplifier monitoring.

ArenaMatch AM40



PowerMatch PM8500 / PM8500N power amplifier



1.1.1. Audio Devices:

- 1.1.1.1. Bose PowerMatch PM 8500N Amplifiers
- 1.1.1.2. Bose ArenaMatch AM20 and AM40 loudspeakers
- 1.1.1.3. Bose RoomMatch RMS218 subwoofer

RoomMatch RMS218 subwoofer



2. PROJECT SPECIFIC INSTALLATION CONSIDERATIONS: (NOTE)

2.1. AVI will provide onsite integration services for defined phases of the construction project:

- 2.1.1. The prerequisite tasks that are shown for each phase must be completed before AVI can proceed with the integration process.
- 2.1.2. Return trips to the jobsite due to incomplete construction tasks that prevent AVI from completing scheduled work are not included in this bid response and will be assessed a Mobilization Fee and Travel Expenses as detailed below. (Section 7.5)

2.2. Installation phase 1: (NOTE)

- 2.2.1. Prerequisite 1 (ie. All conduit and cable path must be complete)
- 2.2.2. Prerequisite 2 (ie. Cable (installed by EC) must be in place and tested)
- 2.2.3. Add as needed.....
- 2.2.4. Timeframe prerequisite (ie. The installation process is expected to take 10 business days to complete and must be scheduled and planned for accordingly in the construction timeline.)
- 2.2.5. (ie. These days would be scheduled after completion of all prerequisite tasks shown above)

2.3. Installation phase 2: (NOTE)

- 2.3.1. Prerequisite 1 (ie. All conduit and cable path must be complete)
- 2.3.2. Prerequisite 2 (ie. Cable (installed by EC) must be in place and tested)
- 2.3.3. Add as needed.....
- 2.3.4. Timeframe prerequisite (ie. The installation process is expected to take 10 business days to complete and must be scheduled and planned for accordingly in the construction timeline.)
- 2.3.5. (ie. These days would be scheduled after completion of all prerequisite tasks shown above)

2.4. Testing/Commissioning: (NOTE)

- 2.4.1. Prerequisite 1 (ie. All previous phases must have been completed)
- 2.4.2. Prerequisite 2 (ie. AVI will require access to all spaces that include AV components for final testing)
- 2.4.3. Prerequisite 3 (ie. AV connection locations must be accessible in each area for testing)
- 2.4.4. Prerequisite 4 (ie. The areas must be available to perform acoustic testing without excessive construction noise)
- 2.4.5. Timeframe prerequisite (ie. The Testing/Commissioning process expected to take 5 business days to complete and must be scheduled and planned for accordingly in the construction timeline.)
- 2.4.6. (ie. These days would be after completion of all prerequisite tasks shown above)

3. KNOWLEDGE TRANSFER (TRAINING)

- 3.1. This is geared specifically towards the end-user / operator. The purpose of this knowledge transfer is to provide operators with the necessary knowledge to confidently and comfortably operate all aspects of the integrated system. Training is to be performed at the time of system completion unless specified below.
 - 3.1.1. -

4. EXCLUSIONS: The following work is **not included** in our Scope of Work:

- 4.1. All conduits, high voltage, wiring panels, breakers, relays, boxes, receptacles, etc.
- 4.2. Concrete saw cutting and/or core drilling
- 4.3. Fire wall, ceiling, roof and floor penetration
- 4.4. Necessary gypsum board replacement and/or repair
- 4.5. Necessary ceiling tile or T-bar modifications, replacements and/or repair
- 4.6. Installation of ceiling mounted projection screen
- 4.7. All millwork (moldings, trim, cut outs, etc.)
- 4.8. Patching and Painting
- 4.9. Permits (unless specifically provided for and identified within the contract)
- 4.10. Unless specifically noted lifts and scaffolding are not included

5. NOTICE: THIS SCOPE OF WORK IS DELIVERED ON THE BASIS OF THE FOLLOWING ASSUMPTIONS:

- 5.1. The room(s) match(es) the drawings provided
- 5.2. Site preparation by others includes electrical and data placement per specifications.
- 5.3. Site preparation will be verified by AVI Systems project manager or representative before scheduling of the installation. All work areas should be clean and dust free prior to the beginning of on-site integration of electronic equipment.
- 5.4. Customer communication of readiness will be considered accurate and executable by AVI Systems project manager.
- 5.5. In the event of any arrival to site that AVI Systems is not able to execute work and definable progress, the Customer will be charged a **\$250.00 Mobilization Fee & Travel Expenses** to offset the lost time due to the lack of readiness. The Mobilization

Fee & Travel Expenses will be presented as a Contract Change Order and will/may halt work until acceptance by the Customer and rescheduling of the integration effort is agreed upon.

- 5.6. Rescheduling and redeployment of AVI Systems technicians due to unacceptable site preparation may cause scheduling delays of up to 15 business days.
- 5.7. There is ready access to the building / facility and the room(s) for equipment and materials.
- 5.8. There is secure storage for equipment during a multi-day integration.
- 5.9. If Customer furnished equipment and existing cabling is to be used, AVI Systems assumes that these items are in good working condition at this time and will integrate into the designed solution. Any repair, replacement and/or configuration of these items that may be necessary will be made at an additional cost.
- 5.10. All Network configurations including IP addresses are to be provided, operational and functional before AVI Systems final integration begins. AVI Systems will not be responsible for testing the LAN connections.
- 5.11. Cable or Satellite drops must be in place with converter boxes operational before the completion of integration. Any delay resulting in extra work caused by late arrival of these items will result in a change order for time and materials.
- 5.12. Document review / feedback on drawings / correspondence will be completed by the Customer within two business days (unless otherwise noted).
- 5.13. The documented Change Control process will be used to the maximum extent possible – the Customer will have an assigned person with the authority to communicate/approve project Field Directed Change Orders and Contract Change Orders (see Appendix).

6. AVI SYSTEMS, INC. GENERAL INTEGRATION SERVICES RESPONSIBILITIES

- 6.1. AVI Systems, Inc. will provide services/work for the project as described above in the Scope of Work or per the attached separate Scope of Work document detailing the scope of work to be performed.
- 6.2. Provide equipment, materials and service items per the contract products and services detail.
- 6.3. Provide systems equipment integration and supervisory responsibility of the equipment integration.
- 6.4. Provide systems configuration, checkout and testing.
- 6.5. Provide project timeline schedules.
- 6.6. Coordinate with the owner/contractor or other parties involved with this project to insure that proper AC electrical power and cableways and/or conduits are provided to properly integrate the equipment within the facilities.
- 6.7. Provide manufacturer supplied equipment documentation.
- 6.8. Provide final documentation and "as built" system drawings
- 6.9. Provide system training following integration to the designated project leader or team as directed in the project specification documents.

7. GENERAL CUSTOMER INTEGRATION SERVICES RESPONSIBILITIES

- 7.1. Provide for the construction or modification of the facilities for soundproofing, lighting, electrical, HVAC, structural support of equipment, and decorating as appropriate.
- 7.2. Provide for the ordering, provisioning, installation, wiring and verification of any Data Network (LAN, WAN, T1, ISDN, etc.) and Telephone Line (Analog or Digital) equipment and services prior to on-site integration.
- 7.3. Provide all necessary cableways and/or conduits required to facilitate AV systems wiring.
- 7.4. Provide all necessary conduit, wiring and devices for technical power to the AV systems equipment.
- 7.5. Provide reasonable accesses of AVI Systems, Inc. personnel to the facilities during periods of integration, testing and training, including off hours and weekends.
- 7.6. Provide a secure area to house all integration materials and equipment.
- 7.7. Provide a project leader who will be available for consultation and meetings.
- 7.8. Provide timely review and approval of all documentation (Technical Reports, Drawings, Contracts, etc.).

PRODUCTS AND SERVICES DETAIL

PRODUCTS:

<u>Mfg</u>	<u>Description</u>	<u>Qty</u>	<u>Price</u>
Speakers			
BOSE	ArenaMatch AM10/80 Outdoor Loudspeaker	4	
BOSE	ArenaMatch AM20/80 Outdoor Loudspeaker	24	
BOSE	ArenaMatch AM40/80 Outdoor Loudspeaker	32	
BOSE	ArenaMatch AM20/100 Outdoor Loudspeaker	8	
BOSE	ArenaMatch AM40/100 Outdoor Loudspeaker	8	
BOSE	ArenaMatch AMWG2010 Waveguide	2	
BOSE	ArenaMatch AMWG4010 Waveguide	4	
BOSE	ArenaMatch AMMCPLAT Module Connect Plate	54	
BOSE	ArenaMatch AMAPLONG Array Plates Long Kit	18	
BOSE	ArenaMatch AMPULL Array Pullback Bracket	8	
BOSE	ArenaMatch AMAPSPRD Array Spreader Bar	8	
Sub-Total: Speakers			\$213,650.56
Subwoofers			
BOSE	RoomMatch Dual-18 VLF-Sub Loudspeaker Black	6	
Sub-Total: Subwoofers			\$18,747.42
Amplifiers			
BOSE	PowerMatch PM8500N Configurable Amplifier Network Model 120V NA	28	
BOSE	PowerMatch PM4500N Configurable Amplifier Network Model 120V NA	4	
Sub-Total: Amplifiers			\$89,915.08
Integration			
	Bean Clamps	44	
	Engineering & Drawings		
	Project Management		
	Programming		
	On Site Integration		
	Testing & Acceptance		
	Travel		
	Travel Expense		
Sub-Total: Integration			\$170,009.40
Total:			<u>\$492,322.46</u>

Refer to page 1 for the Grand Total that includes the Taxes, and Shipping & Handling

AVI Systems General Terms and Conditions of Sale

The following General Terms & Conditions of Sale (the "T&Cs") in combination with either (a) a signed Retail Sales Agreement or (b) Quote under which AVI Systems, Inc ("AVI") agrees to supply goods or services constitute a binding contract (the "Agreement") between AVI and the entity identified on page one of the Retail Sales Agreement or Quote (the "Customer"). In the absence of a separately negotiated "Master Services Agreement" between AVI and Customer signed in "wet ink" by the Chief Executive Officer or Chief Financial Officer of AVI, these T&C's shall apply. Any terms and conditions set forth in any correspondence, purchase order or Internet based form from Customer to AVI which purport to constitute terms and conditions which are in addition to those set forth in this Agreement or which attempt to establish conflicting terms and conditions to those set forth in this Agreement are expressly rejected by AVI unless the same has been manually countersigned in wet ink by an Officer of AVI.

1. **Changes In The Scope of Work** – Where a Scope of Work is included with this Agreement, costs resulting from changes in the scope of this project by the Customer, including any additional requirements or restrictions placed on AVI by the Customer or its representatives, will be added to the contract price. When AVI becomes aware of the nature and impact of the change, a contract Change Order will be submitted for review and approval by the Customer before work continues. AVI has the right to suspend the work on the project pending Customer's written approval of the Change Order.
2. **Proprietary Protection of Programs** - AVI and client will BOTH store current and up-to-date versions of all programs, source code, IP schemes, DSP files etc for the duration of the project and following the project completion provide AVI is retained under an SSA agreement.
3. **Shipping and Handling and Taxes** –City will not be responsible for any damage until the equipment is located inside the city facility during installation. Ie: city will not pay for damage caused by AVI or others outside their control. However, city will be responsible if one of their contractors or employees damages the equipment while product is in city hall during installation. AVI will be responsible for any damages caused by personnel responsible for installation. The city of Fargo will ensure equipment is secured after equipment has been delivered to prevent theft.
4. **Title** – Where applicable, title to the Equipment passes to the Customer on the earlier of: (a) the date of shipment from AVI to Customer, or (b) the date on which AVI transmits its invoice to Customer.
5. **Security Interest** – In addition to any mechanics' lien rights, the Customer, for value received, hereby grants to AVI a security interest under the North Dakota commercial code together with the a security interest under the law(s) of the state(s) in which work is performed or equipment is delivered. This security interest shall extend to all Equipment, plus any additions and replacements of such Equipment, and all accessories, parts and connecting Equipment now or hereafter affixed thereto. This security interest will be satisfied by payment in full unless otherwise provided for in an installment payment agreement. The security interest shall be security for all sums owed by Customer under this Agreement. A copy of this Agreement may be filed as a financing statement with the appropriate authority at any time after signature of the Customer. Such filing does not constitute acceptance of this Agreement by AVI
6. **Risk of Loss or Damage** – Notwithstanding Customer's payment of the purchase price for Equipment, all risk of loss or damage shall transfer from AVI to Customer upon transfer of Title to Customer. Customer shall be responsible for securing insurance on Equipment from this point forward.
7. **Receiving/Integration** – Unless the Agreement expressly includes integration services by AVI, the Customer agrees to furnish all services required for receiving, unpacking and placing Equipment in the desired location along with integration. Packaging materials shall be the property of the Customer.
8. **Equipment Warranties** – To the extent AVI receives any warranties from a manufacturer on Equipment; it will pass them through to Customer to the full extent permitted by the terms of each warranty. Factory warranties vary by manufacturer, and no additional warranties are expressed or implied.
9. **General Warranties** – Each Party represents and warrants to the other that: (i) it has full right, power and authority to enter into and fully perform its obligations under this Agreement, including without limitation the right to bind any party it purports to bind to this Agreement; (ii) the execution, delivery and performance of this Agreement by that Party does not conflict with any other agreement to which it is a Party or by which it is bound, and (iii) it will comply with all applicable laws in its discharge of its obligations under this Agreement. AVI warrants, for a period of 90 days from Substantial Completion, the systems integration to be free from defects in workmanship. EXCEPT AS SET FORTH IN THIS AGREEMENT, AVI DISCLAIMS ANY EXPRESS OR IMPLIED WARRANTIES WITH REGARD TO THE EQUIPMENT, MATERIALS AND SERVICES PROVIDED BY AVI, INCLUDING WITHOUT LIMITATION WARRANTIES OF MERCHANTABILITY, NON INFRINGEMENT AND TITLE. CITY HAS RELIED ON AVI CONSULTING TO IDENTIFY PRODUCT WILL MEET THEIR NEEDS.
10. **Indemnification** – Customer shall defend, indemnify and hold harmless AVI against all damages, claims, liabilities, losses and other expenses, including without limitation reasonable attorneys' fees and costs, (whether or not a lawsuit or other proceeding is commenced), that arise in whole or in part from: (a) any negligent act or omission of Customer, its agents, or subcontractors, (b) Customer's failure to fully conform to all laws, ordinances, rules and regulations which affect the Agreement,. If Customer fails to promptly indemnify and defend such claims and/or pay AVI's expenses, as provided above, AVI shall have the right to defend itself, and in that case, Customer shall reimburse AVI for all of its reasonable attorneys' fees, costs and damages incurred in settling or defending such claims within thirty (30) days of each of AVI's written requests. AVI shall indemnify and hold harmless Customer against all damages, claims, liabilities, losses and other expenses, including without limitation reasonable attorneys' fees and costs, (whether or not a lawsuit or other proceeding is commenced), to the extent that the same is finally determined to be the result of (a) any grossly negligence or willful misconduct of AVI , its agents, or subcontractors, (b) AVI's failure to fully conform to any material law, ordinance, rule or regulation which affects the Agreement.

11. Remedies – Upon default as provided herein, AVI shall have all the rights and remedies of a secured party under the Minnesota commercial code and under any other applicable laws. Any requirements of reasonable notice by AVI to Customer, or to any guarantors or sureties of Customer shall be met if such notice is mailed, postage prepaid, to the address of the party to be notified shown on the first page of this Agreement (or to such other mailing address as that party later furnishes in writing to AVI) at least ten calendar days before the time of the event or contemplated action by AVI set forth in said notice. The rights and remedies herein conferred upon AVI, shall be cumulative and not alternative and shall be in addition to and not in substitution of or in derogation of rights and remedies conferred by the North Dakota commercial code and other applicable laws.

12. Limitation on Liability – EXCEPT IN CIRCUMSTANCES INVOLVING ITS GROSS NEGLIGENCE OR WILLFUL MISCONDUCT, THE TOTAL LIABILITY OF AVI UNDER THIS AGREEMENT FOR ANY CAUSE SHALL NOT EXCEED (EITHER FOR ANY SINGLE LOSS OR ALL LOSSES IN THE AGGREGATE) THE GREATER OF THE NET AMOUNT ACTUALLY PAID BY CUSTOMER TO AVI UNDER THIS AGREEMENT DURING THE TWELVE (12) MONTH PERIOD PRIOR TO THE DATE ON WHICH AVI'S LIABILITY FOR THE FIRST SUCH LOSS FIRST AROSE OR \$1,000,000.

13. No Consequential Damages – AVI SHALL NOT HAVE ANY LIABILITY TO CUSTOMER OR TO ANY OTHER PERSON OR ORGANIZATION WHOSE RIGHT TO BRING A CLAIM, ACTION OR LAWSUIT ARISES OUT OF THIS AGREEMENT FOR ANY INDIRECT, INCIDENTAL, CONSEQUENTIAL, OR SPECIAL DAMAGES OF ANY DESCRIPTION (INCLUDING WITHOUT LIMITATION LOST PROFITS OR LOSS OR INTERRUPTION OF BUSINESS), WHETHER BASED ON CONTRACT, NEGLIGENCE, TORT, OR ANY OTHER LEGAL THEORY, REGARDLESS OF WHETHER ADVISED OF THE POSSIBILITY OF SUCH DAMAGES AND IRRESPECTIVE OF THE NUMBER OR NATURE OF CLAIMS

14. Acceleration of Obligations and Default – Payment in full for all "Equipment," which is defined as all goods identified in the section of the Agreement with the same title, as well for any and all other amounts due to AVI shall be due within the terms of the Agreement. Upon the occurrence of any event of default by Customer, AVI may, at its option, with or without notice, declare the whole unpaid balance of any obligation secured by this Agreement immediately due and payable and may declare Customer to be in default under this Agreement.

15. Choice of Law, Venue and Attorney's Fees – This Agreement shall be governed by the laws of the State of North Dakota in the United States of America without reference to or use of any conflicts of laws provisions therein. For the purpose of resolving conflicts related to or arising out of this Agreement, the Parties expressly agree that venue shall be in the State of North Dakota in the United States of America only, and, in addition, the Parties hereby consent to the exclusive jurisdiction of the federal and state courts located in Cass County, North Dakota in the United States of America and waive any right to assert in any such proceeding that Customer is not subject to the jurisdiction of such court or that the venue of such proceeding is improper or an inconvenient forum. The Parties specifically disclaim application (i) of the United Nations Convention on the International Sale of Goods, 1980, and (ii) of Article 2 of the Uniform Commercial Code as codified

16. General – Headings are for reference purposes only and shall not affect the meaning or interpretation of this Agreement. The Parties acknowledge and agree that the Agreement has been negotiated by the Parties and that each had the opportunity to consult with its respective counsel, and shall be interpreted fairly in accordance with its terms and without any strict construction in favor of or against either Party based on draftsmanship of the Agreement. This Agreement is not assignable by Customer without the prior written consent of AVI. Any attempt by Customer to assign any of the rights, duties, or obligations of this Agreement without such consent is void. AVI reserves the right to assign this Agreement to other parties in order to fulfill all warranties and obligations expressed herein, or upon the sale of all or substantially all of AVI's assets or business. This Agreement can only be modified by a written agreement duly signed by persons authorized to sign agreements on behalf of the Customer and of AVI, and variance from the terms and conditions of the Agreement in any order or other written notification from the Customer will be of no effect. If any provision or provisions of this Agreement shall be held to be invalid, illegal or unenforceable, the validity, legality and enforceability of the remaining provisions shall not in any way be affected or impaired thereby. AVI is not responsible for any delay in, or failure to, fulfill its obligations under this Agreement due to causes such as natural disaster, war, emergency conditions, labor strike, acts of terrorism, the substantial inoperability of the Internet, the inability to obtain supplies, or any other reason or any other cause or condition beyond AVI's reasonable control. Except as otherwise stated in the Agreement, AVI is not obliged to provide any services hereunder for Equipment located outside the United States or Puerto Rico. Scheduled completion dates are subject to change based on material shortages caused by shortages in cable and materials that are industry wide.

17. Confidentiality Each party acknowledges that certain material and information which has or will come into its possession or knowledge in connection with this Agreement may consist of confidential and proprietary information or data which is not readily ascertainable by proper means and which derives economic value, from not being generally known ("Confidential Information") and that the Customer, being a North Dakota political subdivision, is subject to the open records requirements of North Dakota law ((N.D.C.C. §44-04-17.1 *et seq.*). This includes certain computer software programs or source codes that meet the definition of "proprietary information" under said North Dakota law, including N.D.C.C. §44-04-18.4(7). Subject to applicable federal, state or local law, the Customer shall not disclose any Confidential Information concerning the company, unless required by law. If required to disclose any such information, Customer will give the company advance notice as soon as reasonably possible. This paragraph shall survive the termination of this Agreement for any reason.

18. Nonsolicitation - To the extent permitted by applicable law, during the term of this Agreement and for a period of one (1) year after the termination this Agreement, each Party agrees that it shall not knowingly solicit or attempt to solicit any of the other Party's executive employees or employees who are key to such Party's performance of its obligations under this Agreement ("Covered Employees"). Notwithstanding the foregoing, nothing herein shall prevent either Party from hiring as an employee any person who responds to an advertisement for employment placed in the ordinary course of business by that Party and/or who initiates contact with that party without any direct solicitation of that person by that Party or its agents.

19. Price Quotations and Time to Install – AVI often installs systems at the end of a construction project. The price quoted contemplates that AVI shall have access to the location for the time shown for AVI to complete its work after the work of all other contractors is substantially complete which means, generally, all other trades are no longer generating dust in the location, and final carpeting/flooring is installed (the "Prepared Area") Failure to

give AVI access to the Prepared Area for the amount of time shown for the installation may result in increased installation costs, typically in a manner proportionate to the reduction of time given to AVI to complete its work compared to the original schedule.

20. Price Quotations – Unless otherwise specified, all prices quoted reflect a discount for a cash payment (i.e., check, wire transfer) made by Customer in full within the terms of each invoice. Payment in other forms, including credit card, p-card, or other non-cash payments shall be subject to a convenience above the cash price. Please speak to your AVI representative if you have any questions in this regard.

View Contract

Contract

Name: STAGEnet Network Equipment / Audio / Visual / Video

Number: 110

Initial Contract Period: 01/01/2017 Thru: 12/31/2018

Renewed/Extended Through: 12/31/2019

Remaining Renewal Options: 3

Renewal Period: 12 Months

Remaining Extension Options: Up to 12 Months

Environmentally Preferable/Biobased: N

Cooperative Purchase: Y

Mandatory: N

Attachments

Title	Size	Action
Pricing - Discount off list - 12-2018	143 kb	View
Pricing - Discount off list - 7-2018	143 kb	View
SOW (Statement of Work) for any Stagenet Services	39 kb	View
Pricing - Discount off list - 11-2017	141 kb	View
Pricing - Discount off list - 5-2017	125 kb	View
Anixter - Renewal 1	77 kb	View
AVI Systems - Renewal 1	41 kb	View
Corporate Technologies - Renewal 1	271 kb	View
Hardware Group - Renewal 1	56 kb	View
High Point - Renewal 1	390 kb	View
Marco - Renewal 1	689 kb	View
Pinnaca - Renewal 1	419 kb	View
Renewal - Amendment 1 - Network Center	109 kb	View
Renewal - Amendment 1 - Signal Perfection	273 kb	View

Contractors

Contractor	Address	City	Contact	Title	Toll Free Telephone	Fax	Email

Anixter, Inc.	6055 Nathan Lane N., Suite 1400	Plymouth, MN 55442	Dean Nelson Joe Jacques	Contract Rep Contract Rep (backup)	763-656- 4004 763-559- 4422 2690	763- 559- 4422	dean.nelson@anixter.com joe.jacques@anixter.com
AVI Systems, Inc.	1930 E. Century Ave	Bismarck, ND 58503	Steve Butts Trent Slyter	Contract Rep	701-323- 3054 701-323- 3054	701- 258- 2015	steve.butts@avisystems.co Trent.slyter@avisystems.co
Corporate Technologies	2000 44th Street SW, Suite 100	Fargo, ND 58103	Brian Nelson	Contract Rep	701-893- 4014	701- 277- 0012	brian.nelson@gocorptech.c
Hardware Group	7667 Cahill Rd, Suite 400	Minneapolis, MN 55439	Reuben Adams	Global Account Manager	952-852- 3774		reuben.adams@hardware.c
High Points Networks	1207 Prairie Parkway, Suite A	West Fargo, ND 58078	Justin Fetch	Contract Rep	701-499- 5224	701- 499- 5224	justin@highpointnetworks.c
Marco Technologies	2625 41st St S	Fargo, ND 58104	Bryce Nelson	Contract Rep	701-282- 8195		bryce.nelson@marconet.co
Network Center Inc.	3487 S University Dr.	Fargo, ND 58104	Brad Gorder	Contract Rep	701-364- 2459		brad.gorder@netcenter.net
Pinnaca	3487 University Dr.	Fargo, ND 58103	Scott Deutsch Jon Brademeyer	Contract Rep Contract Rep	952-400- 2595 701-446- 8695	952- 931- 7425	sdeutsch@pinnaca.com jbrademeyer@pinnaca.com
Signal Perfection, Ltd.	2730 Arthur Street	Roseville, MN 55113	John Kast	Contract Rep	651-287- 7007		john.kast@avispl.com

Contract Administrator

Name: Peterson Brandy Scherbenske Angie**Telephone:** 701-328-1888**Fax:** 701-328-3000**Email:** blpeterson@nd.gov

CONTRACT AMENDMENT

CONTRACT NAME AND NUMBER: STAGENET NETWORK EQUIPMENT - #110

AMENDMENT NUMBER: 1

This amendment is made to #110 STAGEnet Network Equipment (Contract) between the State of North Dakota, acting through its Information Technology Department in cooperation with the Office of Management and Budget State Procurement Office (STATE), and AVI Systems, Inc. (CONTRACTOR).

The parties agree to the following terms and conditions and expressly agree that if any of the following terms and conditions conflict with any of the terms and conditions of the Contract, then, notwithstanding any term in the Contract, the following terms and conditions govern and control the rights and obligations of the parties.

The parties agree to amend the Contract as follows:



Renewal

Contract Section 5, Term of Contract. The Contract commenced on January 1, 2017 for a period of 24 months with an option to renew the contract for up to four (4) years.

The parties have agreed to renew or extend the Contract for an additional 12 months; therefore, the contract is amended to change the expiration date to December 31, 2019. The Contract has three (3) renewals remaining. The Contract can be extended for an additional 12 months.

All other terms of the Contract remain in effect. This Contract Amendment is not effective until fully executed by all parties.

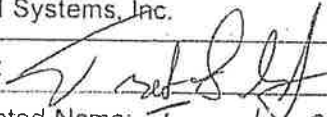
EXECUTION

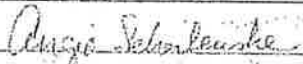
CONTRACTOR	STATE OF NORTH DAKOTA
AVI Systems, Inc.	Acting through its Information Technology Department
BY: 	BY: 
Printed Name: Trent Slyter	Printed Name: Greg Hoffman
Title: Area Vice President	Title: Director, Administrative Services
Date: 8-22-18	Date: 8-13-2018
STATE OF NORTH DAKOTA	
Acting through its ND State Procurement Office	
BY: 	
Printed Name: Angie Scherbenske	
Title: Procurement Officer II	
Date: 08-16-2018	

Professional Services	
AVI Systems	
AVI Systems Integration or Repair Service - Install/Service Tech	\$95/hour
AVI Systems Integration or Repair Service - Project Manager/Lead Tech	\$105/hour
AVI Systems Integration or Repair Service - Programmer/Design Engineer	\$136/hour
AVI Branded UC Support	20%
AVI Branded Pro Support	20%
Block of 40 Hours	
AVI Systems Integration or Repair - Install/Service Tech	\$3,610
AVI Systems Integration or Repair - Project Manager/Lead Tech	\$3,990
AVI Systems Integration or Repair Service - Programmer/Design Engineer	\$5,168
Corporate Technologies	
Networking - On Site	\$105/hour
Advanced Networking - On Site	\$120/hour
Advanced Networking/IPT - On Site	\$120/hour
Hardware Group	
On Site	\$150/hour
Remote - Low Level Design, Prestaging	\$125/hour
High Point	
Block of 10 Hours	\$1,567
Block of 25 Hours	\$3,712
Block of 50 Hours	\$7,012
Block of 100 Hours	\$13,200
Block of 200 Hours	\$24,750
Marco	
Pro AV	\$95/hour
Networking	\$110/hour
Advanced Networking - IP Telephony	\$125/hour
Advanced Networking	\$150/hour
Network Center	
Network Monitoring - Based on total network devices. Monthly monitoring fee is available.	
PC/Desktop Monitoring	\$5/mo/endpoint
AntiVirus	\$2-\$4/mo/endpoint
Technician	\$155/hour
Engineer	\$165/hour
Technician - Block of 100 Hours	\$145/hour
Engineer - Block of 100 Hours	\$155/hour

Pinnaca	
Pinnaca One Call Support	15%
Pinnaca One Call AV Support	15%
Pinnaca One Call Prime Support	15%
Pinnaca One Call Plus Support	15%
Pinnaca Cloud Based Services	15%
Pinnaca Video Infrastructure Labor Service	\$149/hour
Pinnaca General Labor Service	\$95/hour
Pinnaca A/V Phone Service	\$95/hour
Signal Perfection	
Installation	\$95/hour
Onsite Programming	\$125/hour
Onsite Field Technician	\$125/hour
Remote Services Support	\$105/hour

Video Conferencing Equipment, Software & Maintenance

For items not listed please contact the applicable vendor(s) for a percent off list discount

Description	AVI Systems	Corporate Technologies	High Point	Marco	Network Center	Pinnaca	Signal Perfection
Polycom Hardware			10%	30%			29%
Polycom Hardware - DC8	20%					23%	
Polycom Hardware - DC8						27%	
Polycom Hardware - DC10	33%					33%	
Polycom Hardware - DC12	40%					38%	
Polycom Hardware - DC14	48%					43%	
Polycom Hardware - DC16	52%					48%	
Polycom Hardware - RPG 500 & 700	40%						
Polycom Hardware - RPG 310	33%						
Polycom Hardware - Accessories	20%						
Polycom Hardware - RMX, DMA & MCU	48%						
Polycom Hardware - Infrastructure	52%						
Polycom Software	33%		10%	30%			10%
Polycom Software - DC6						23%	
Polycom Software - DC8						27%	
Polycom Software - DC10						33%	
Polycom Software - DC12						33%	
Polycom Maintenance	15%		5%	5%		5%	29%
Cisco/Tandberg - Hardware	38%	39%		39%	20%	36%	31%
Cisco/Tandberg - Software	38%	15%		39%		36%	31%
Cisco/Tandberg - Maintenance	20%	15%		30%		10%	31%
Lifesize - Hardware	10%		10%	20%		15%	15%
Lifesize - Software	10%		10%	20%		15%	15%
Lifesize - Maintenance	20%		5%	5%		15%	15%
Pexip Software	42%					10%	29%
Pexip Maintenance	20%					10%	15%
Sony Hardware	25%			20%	15%	15%	
Sony Software	20%			20%		15%	
Sony Maintenance	20%			5%		15%	
Minimum Percent Off List	14%	10%	5%	5%	5%	5%	15%

From: Kathy Skramstad <kathy.skramstad@avisystems.com>
Sent: Thursday, May 30, 2019 9:47 AM
To: Rob Sobolik
Subject: RE: AVI Quote

CAUTION: This email originated from an outside source. Do not click links or open attachments unless you know they are safe.

Not you are not missing it....it's confusing...

Bose is not spelled out directly. At the bottom of the Video Conferencing tab it shows a line item of Minimum % off list. Then at the top of the other tabs, it says for anything not listed contact the vendor for minimum percent off list. So you are guaranteed 14% off list. However you are getting 42% off list for the Bose equipment.

Minimum Percent Off List	14%
--------------------------	-----

From: Rob Sobolik <rsobolik@fargodome.com>
Sent: Thursday, May 30, 2019 9:34 AM
To: Kathy Skramstad <kathy.skramstad@avisystems.com>
Subject: RE: AVI Quote

Am I missing something? I do not see on any of the tabs, either the pricing sheet you attached or using the link to the contract, anywhere that it lists the BOSE equipment and the discount rate like it does for other items.

Rob Sobolik
General Manager
Fargodome
Telephone: 701-241-9100
Fax: 701-237-0987

From: Kathy Skramstad [<mailto:kathy.skramstad@avisystems.com>]
Sent: Thursday, May 30, 2019 9:00 AM
To: Rob Sobolik <rsobolik@fargodome.com>
Subject: RE: AVI Quote

CAUTION: This email originated from an outside source. Do not click links or open attachments unless you know they are safe.

Attached is the pricing. It is under the Stagenet Contract number 110 <https://apps.nd.gov/csd/spo/services/bidder/listCurrentContracts.do>

Is that what you are looking for?

Kathy

From: Rob Sobolik <rsobolik@fargodome.com>
Sent: Thursday, May 30, 2019 8:34 AM
To: Kathy Skramstad <kathy.skramstad@avisystems.com>
Subject: RE: AVI Quote

Kathy,

What are the chances that you have a copy of the contract/agreement between AVI and whichever government agency you have the agreement with that is being used for this project?

Rob Sobolik
General Manager
Fargodome
Telephone: 701-241-9100
Fax: 701-237-0987

From: Kathy Skramstad [<mailto:kathy.skramstad@avisystems.com>]
Sent: Tuesday, May 28, 2019 10:53 AM
To: Rob Sobolik <rsobolik@fargodome.com>; Matt Costello <mcostello@fargodome.com>
Subject: RE: AVI Quote

CAUTION: This email originated from an outside source. Do not click links or open attachments unless you know they are safe.

Rob, you are correct – My apologies. I also changed T&C's to match what COF attorney agreed to. There were some confidentiality statements that were eliminated and changed.

Kathy

From: Rob Sobolik <rsobolik@fargodome.com>
Sent: Tuesday, May 28, 2019 10:43 AM
To: Kathy Skramstad <kathy.skramstad@avisystems.com>; Matt Costello <mcostello@fargodome.com>
Subject: RE: AVI Quote

Kathy,

As I read through this agreement, I have a question for clarification. In section 2 of the agreement (Project Specific Installation Considerations), I notice in subsections 2.2 and 2.3 (Installation Phase 1 & 2), there are items listed as follows:

- 2.2.1 Prerequisite 1 (ie. All conduit and cable path must be complete)
- 2.2.2 Prerequisite 2 (ie. Cable (installed by EC) must be in place and tested)

And that is repeated for subsection 2.3.

It is my understanding that this will not be needed for this upgrade as all of the existing cabling and electrical will be re-used and will work for this project. This project only involves a component switch out of amps, subwoofers and speaker boxes & components.



12

FARGO CASS PUBLIC HEALTH
1240 25th Street South
Fargo, ND 58103-2367
Phone 701-241-1360
Fax 701-241-1366
FargoCassPublicHealth.com

M E M O R A N D U M

TO: BOARD OF CITY COMMISSIONERS

FROM: DESI FLEMING 
DIRECTOR OF PUBLIC HEALTH

DATE: JUNE 4, 2019

RE: CONTRACTS FOR SIGNATURE
FARGO PUBLIC SCHOOL DISTRICT \$510,597.71

The attached contract with Fargo Public Schools is for nursing services for the school year 2019-2020.

No budget adjustment is required for this contract.

If you have any questions, please contact me at 241-1380.

Suggested Motion: Move to approve the Service Agreement with Fargo Public Schools for nursing services.

DF/lls
Enclosure

**PURCHASE OF SERVICE AGREEMENT
FARGO PUBLIC SCHOOL DISTRICT**

Whereas the Fargo Public School District hereinafter referred to as District, has agreed to purchase the services described in the "Scope of Service" (Attachment A); and

Whereas, Fargo Cass Public Health, 1240 25th Street South, Fargo, North Dakota 58103-2367 hereinafter referred to as Provider desires to provide the services described in the "Scope of Services" (Attachment A):

Now, therefore the District and the Provider enter into the following:

I. TERMS OF CONTRACT

The term of this contract shall be for school year 2019-2020, beginning on July 1, 2019 and ending on June 30, 2020. This contract may be renewed for subsequent school years by written agreement of the parties. Provided, that either party may terminate this contract at any time upon thirty (30) days written notice to other.

II. TERMINATION

In the event the agreement is terminated, the termination shall be without prejudice to any obligations or liabilities of either party for services provided prior to such termination.

III. SCOPE OF SERVICE

The Provider agrees to provide services in accordance with documentation in this contract.

IV. COMPENSATION

1. The District agrees to reimbursement for service in accordance with the agreed upon charges in this contract (Attachment B). The billing will occur monthly, at the previously determined rate of 65 percent for the district and 35 percent for the provider. The hours to be billed will include the scheduled nursing time, any annual or sick leave taken by the nursing personnel and holiday pay as determined by the City of Fargo.
2. Fargo Public School District did request an increase in RN time for the secondary sites. An additional 2.5 hours per week for 35 weeks will be added to the contract to be provided over the five days in the week.
3. The provider will attempt to get substitute nursing coverage, when the regularly scheduled nurse is on an extended leave.
4. The provider will ensure all staff assigned to the District communicate absences and adjustments to scheduled hours in advance, as able, with the building principal or administrative assistant. Attendance concerns will be handled immediately by the provider upon notice from the district.

V. CHANGES

No change or amendment to this agreement may be made unless made in writing signed by the parties.

VI. NO GRANT OF AUTHORITY TO CONTRACT ON BEHALF OF THE DISTRICT

No part of this agreement shall be construed to grant to the Provider any authority to contract for on behalf of or incur obligations on behalf of the District.

VII. AUTHORITY TO SUBCONTRACT

The Provider may subcontract with qualified providers of services, provided that any subcontract must acknowledge the binding nature of this agreement and incorporate this agreement, together with its attachments. The Provider agrees to be solely responsible for the performance of any subcontractor.

VIII. INDEPENDENT CONTRACTOR

The Provider is performing the duties under this agreement as an independent contractor. No part of this agreement, or the arrangements made by the parties to perform this agreement, shall be construed as creating an employer/employee relationship.

IX. COPYRIGHT

The District reserves a right to copy or reproduce any materials created or produced, by the Provider, in performance of this agreement except with confidential health information.

X. AGREEMENT CONSTITUTES CONTRACT

This agreement shall constitute the entire contract, between the parties, for performance of the Scope of Service. There are no other agreements, either verbal or written, that alter or affect this agreement.

XI. PROVIDER ASSURANCES

The Provider agrees to comply with the applicable provider Assurances hereto attached, on Attachment C.

XII. INTEGRATION AND MODIFICATION

This contract constitutes the entire agreement between the Provider and the District. No alteration, amendment or modification in the provisions of this agreement shall be effective unless it is reduced to writing signed by the parties and attached hereto.

XIII. COLLATERAL CONTRACTS

Where there exists any inconsistency between this agreement and other provisions of collateral contractual agreements which are made a part of this agreement by reference or otherwise, the provisions of this agreement shall control.

XIV. ACCESS TO RECORDS

Fargo Cass Public Health and the North Dakota State Health Department, and their duly authorized representatives, shall have access to the books, documents, paper and records of the District, which are pertinent, as determined by Fargo Cass Public Health, to this contract for the purpose of making audit, examination, excerpts, and transcripts.

XV. RETENTION OF RECORDS

The Provider agrees to retain financial and program records. The District is responsible for student records including, all electronic health information, if applicable, and will follow their own retention policy.

XVI. CONFIDENTIALITY

The Provider will not, except upon the written consent of the recipient's or their responsible parent, guardian, or custodian, use or cause to be used any information concerning such individual for any purpose not directly connected with the District or the Provider's responsibilities with respect to services purchased hereunder. The District acknowledges their role in abiding by the adherence to FERPA regulations relative to educational records confidentiality in order to protect student privacy. The consequences of failing to comply with FERPA must be borne by the School District and not Fargo Cass Public Health.

XVII. APPLICABLE LAW

This agreement shall be governed by and construed in accordance with the laws of the State of North Dakota.

XVIII. CAPTIONS

The captions or heading in this agreement are for convenience only and in no way define, limit, or describe the scope of intent of any provisions of this agreement.

XIX. EXECUTION AND COUNTERPARTS

This agreement may be executed in several counterparts, each of which shall be an original, all of which shall constitute but one of the same instrument.

XX. AMENDMENTS

The terms of this agreement shall not be waived, altered, modified, supplemented, or amended, in any manner whatsoever, except by written instrument signed by the parties.

XXI. NOTICES

All notices, certificates or other communications shall be sufficiently given when delivered or mailed, postage prepaid, to the parties at their respective places of business as set forth in the preamble to this agreement or at a place designated hereafter in writing by the parties.

XXII. SUCCESSORS IN INTEREST

The provisions of this agreement shall be binding upon and shall insure to the benefit of the parties hereto, and their respective successors and assigns.

XXIII. SEVERABILITY

The parties agree that any term or provision of this contract is declared by a court of competent jurisdiction to be illegal or in conflict with any law, the validity of the remaining terms and provisions shall not be affected, and the rights and obligations of the parties shall be construed and enforced as if the contract did not contain the particular term or provision held to be invalid.

XXIV. WAIVER

The failure of the District to enforce any provisions of this contract shall not constitute a waiver by the District of that or any other provision.

XXV. MERGER CLAUSE

This agreement constitutes the entire agreement between the parties. No waiver, consent, modification or change of terms of this agreement shall bind either party unless in writing and signed by both parties. Such waiver, consent, modification or change, if made, shall be effective only in modification or change, if made, shall be effective only the specific instance and for the specific purpose given. There are no understandings, agreements, or representatives, oral or written, not specified herein regarding this agreement. Provider, by the signature below of its authorized representative, hereby acknowledges that the Provider has read this agreement, understands it and agrees to be bound by its terms and conditions.

XXVI. INDEMNIFICATION AND HOLD HARMLESS

The District hereby agrees to indemnify and hold the Provider, its officers, agents, employees, and members, harmless from any and all claims, demands and causes of action which may be asserted against the Provider as a result of

the rendering of any of the services by the Provider which are described in this Agreement. The obligation of the District under the terms of this provision shall include the duty to provide a legal defense of such claims; provided that this provision shall not be construed to require reimbursement of any legal expenses incurred by the District, without prior written approval of the District.

XXVII. COMPLIANCE WITH LAWS

The Provider shall comply with all federal, state, and local laws and ordinances applicable to the work to be done under this agreement.

XXVIII. NON-DISCRIMINATION

The Provider makes available all services and assistance without regard to race, color, national origin, religion, age, sex, or handicap, and is subject to Title VI of the Civil Rights Act of 1964. Section 504 of the Rehabilitation Act of 1975 as amended. Persons who contract with or receive funds to provide services for Provider are obligated to abide by the provisions of their federal laws. Questions concerning the contractor's or provider's obligations under these acts may be directed to the Provider's representative as set forth in the signature block of this agreement, at the address established in the agreement, or the Branch Chief, Officer for Civil Rights, Region VIII, Federal Office Building, 1961 Stout Street, Denver, Colorado 82094.

SERVICES PROVIDED: See Attachment A (Goals and Objectives)

REIMBURSEMENT: See Attachment B (Budget)

PROVIDER-FARGO CASS PUBLIC HEALTH

FARGO PUBLIC SCHOOL DISTRICT

TIMOTHY J. MAHONEY, MAYOR, CITY OF FARGO

JACKIE GAPP, CPA, SFO

DATE

Business Manager
TITLE

DESI FLEMING, DIRECTOR OF PUBLIC HEALTH

6/4/2019
DATE

6/5/19
DATE

ATTACHMENT A

SCHOOL HEALTH PROGRAM A COLLABORATIVE PROGRAM BETWEEN FARGO PUBLIC SCHOOL DISTRICT AND FARGO CASS PUBLIC HEALTH

PURPOSE: The purpose of this partnership is to share expertise, time, energy, and economic resources to coordinate and provide a comprehensive health program in our school community.

GOALS: The goal of this program is to provide Public Health School Nurse services and/or Nurse Aide services to all components of the Fargo Public School District health program: education, environment and services.

- A. Improve the student and family access to community health services.
- B. Improve the early identification, referral, and follow-up of students experiencing unresolved health problems.
- C. Determine the current compliance rate for follow-up on health screening results and on immunization requirements.
- D. Improve the students' access to basic health services at school for first aid symptom management and medications.

OBJECTIVES:

The Public Health School Nurse is a liaison between education and health care and will provide a link between the school, home and community. The nurse will:

- A. Manage health care in the school health program
The nurse will participate in planning, implementation, and evaluation of the program.
- B. Deliver health services
The nurse will deliver health services to the client system using systematic processes to assess needs, plan interventions, and evaluate outcomes so that high-level wellness can be achieved. The nurse will also monitor follow through related to health referrals. The nurse aide, if applicable, will deliver health services primarily focused on first aid, medication administration or emergencies. The nurse aide will work in conjunction with the nurse assigned to that building and will be supervised by that nurse.
- C. Advocate for the health rights of children
The nurse will act as an advocate for the health rights of children and their families both within the school and between the school and community.
- D. Provide health consult for individuals and groups
The nurse will provide health counseling and guidance for the client system on an individual basis or within a group setting.
- E. Provide health education
The nurse will participate in health education program activities for children, youth, school personnel, and the community.

**ATTACHMENT B
2019-2020**

SCHOOL HEALTH SERVICES BUDGET

FARGO SCHOOL DISTRICT PROPOSED FUNDING FOR SCHOOL HEALTH SERVICES	AMOUNT
260 RN HOURS /WEEK X 35 WEEKS AT \$42.00 /HOUR	\$382,200.00
+ 2.5 RN HOURS/WEEK X 35 WEEKS AT \$42.00/HOUR X 6 RN'S FOR SECONDARY	\$22,050.00
574 HOURS OF ADMINISTRATIVE NURSING SUPPORT AT \$50.29/HOUR	\$ 28,866.46
87.5 NURSE'S AIDE HOURS/WEEK X 35 WEEKS AT \$25.30/HOUR	\$77,481.25
TOTAL	<u>\$510,597.71</u>
DISTRICT PORTION AT 65 % OF \$510,597.71	\$331,888.51
PROVIDER PORTION AT 35% OF \$510,597.71	\$178,709.20
TOTAL FOR DISTRICT	\$331,888.51

ATTACHMENT C

PROVIDER ASSURANCES

- A. All licensing or other standards required by Federal and State Law and regulations and by ordinance of the City and county in which the services purchased hereunder are provided will be complied with in full for the duration of this contract.
- B. No qualified person(s) shall be denied services purchased hereunder, or be subjected to discrimination, because of face, religion, color, national origin, sex, age, or handicap.
- C. The Provider will abide by the provisions of Title VII of the Civil Rights Act of 1964 (42 USC 2000C) which prohibits discrimination against any employee or applicant for employment because of race, religion, color, national origin, sex, age, or handicap. In addition, the Provider agrees to abide by Executive Order 11246, as amended by Executive Order No. 11375, which prohibit discrimination because of sex.
- D. The Provider will comply with Section 504 of the Rehabilitation Act of 1973, as amended, and all requirements imposed by and pursuant to regulations promulgated thereunder to the end that no otherwise qualified handicapped individual shall, solely by reason of their handicap, be excluded from participation in, be denied benefits of or be subjected to discrimination under any program in the provision of services under this agreement.
- E. The Provider will not, except upon the written consent of the affected individual or their responsible parent, guardian or custodian, use or cause to be used, any information concerning such individual for any purpose not directly connected with Board or the Provider's responsibilities with respect to services purchased hereunder.
- F. Unless otherwise authorized by federal law, the charges to be made by the Provider do not include costs financed by federal monies other than those generated by this agreement.
- G. The Provider shall not assign this agreement.
- H. Provider assures that the sources from which it purchases goods and services used for the provision of the services described in the agreement will conform to applicable provisions of Executive Order 11346, Equal Opportunity.

13

M E M O R A N D U M

TO: BOARD OF CITY COMMISSIONERS

FROM: TIA BRASETH, COMMUNITY DEVELOPMENT PLANNING COORDINATOR TB.
NICOLE CRUTCHFIELD, PLANNING DIRECTOR

DATE: JUNE 13, 2019

RE: APPROVE SUBMISSION OF HUD 2019 COMMUNITY DEVELOPMENT BLOCK GRANT (CDBG) & HOME ACTION PLAN AND PRIOR YEAR AMENDMENTS

Following the Public Hearing at the May 20, 2019 City Commission meeting and the required public comment period, staff is seeking approval of the following HUD program actions:

- Submission of the 2019 Action Plan for Community Development Block Grant (CDBG) and HOME programming and expenditures
 - Details on specific activities are outlined in the attached public notice (*published in the May 13, 2019 Forum newspaper*)
- Submission of prior year amendments to 2018 Action Plan and 5-Year Plan
 - Cancelling two 2018 Action Plan projects that did not come to fruition
 - Slum & Blight Abatement/Hazardous Property Clearance: -\$250,000 CDBG budget
 - Affordable Housing Development: +\$284,049 CDBG budget

The 2019 Action Plan and amendments are in compliance with federal regulations and consistent with the approved 5-Year Consolidated Plan (2015-2019). The 2019 draft Action Plan is available on the City website (posted May 10). No public comments were received during the 30-day public comment period. The following timeline outlines actions required by the City's Citizen Participation Plan:

Timeline for 2019 Action Plan & Prior Year Amendments	Date	Status
<i>Advertisement for Public Meeting</i>	<i>Jan 7</i>	<i>Complete</i>
<i>Public Meeting</i>	<i>Jan 8</i>	<i>Complete</i>
<i>Approved by Community Development Committee</i>	<i>April 23</i>	<i>Complete</i>
<i>Approved by Planning Commission</i>	<i>May 7</i>	<i>Complete</i>
<i>Advertisement for Public Comment Period & Hearing</i>	<i>May 13</i>	<i>Complete</i>
<i>30-Day Public Comment Started</i>	<i>May 13</i>	<i>Complete</i>
<i>Public Hearing at City Commission Meeting (No Comments Received)</i>	<i>May 20</i>	<i>Complete</i>
<i>30-Day Public Comment Ends</i>	<i>June 12</i>	<i>Complete</i>
<i>Final City Commission Consideration/Approval (on consent)</i>	<i>June 17</i>	
<i>Submit Plan to US Department of Housing & Urban Development</i>	<i>June 18</i>	

Recommended Motion: Approve submission of 2019 Action Plan and prior year amendments to the US Department of Housing and Urban Development.



**Notice of Public Hearing & Public Comment Period
Community Development Block Grant (CDBG) & HOME Programs
2019 Action Plan and Budget
&**

**Amendments to:
2018 Action Plan Activities and Budget/5-Year Consolidated Plan Activity**

2019 Action Plan & Budget Proposal

The City of Fargo has prepared a draft version of the 2019 Annual Action Plan for Housing and Community Development for the Community Development Block Grant (CDBG) and HOME Programs. The priorities established within the draft plan result from citizen participation in the development of the 2015-2019 Consolidated Plan and a January 8, 2019 community meeting. The City's 5-Year priorities include affordable housing, activities to end homelessness, neighborhood revitalization, and poverty reduction.

Estimated Resources

During the 2019 program year, the City of Fargo estimates the following resources to be available:

- **\$760,623** – 2019 Community Development Block Grant (CDBG) allocation from HUD
- **\$82,000** – 2019 CDBG Program Income (estimated)
- **\$347,426** – 2018 Unobligated or Reallocated CDBG Funds at 2018 Year-End (estimated)
- **\$454,741** – 2019 HOME PJ allocation from HUD
- **\$43,800** – 2018 HOME PJ Program Income (actual)
- **\$331,944** – 2018 Unobligated HOME PJ Funds at 2018 Year-End (estimated)
- **\$127,501** – 2017 Unobligated HOME PJ Program Income at 2018 Year-End (estimated)
- **\$75,314** – 2017 Unobligated HOME PJ Funds at 2018 Year-End (estimated)

Total = \$2,223,349 (estimated)

Activity & Budget Summary Chart

Activity	Description	Budget
Planning, Administration, and Fair Housing	Staff support for planning, implementation, reporting, and monitoring of CDBG and HOME resources. <i>National Objective: Not applicable for administration. CDBG Matrix Code: 21A General Program Administration. Eligibility 24 CFR Part 570.206.</i> <u>High Plains Fair Housing Center</u> : Budget \$5,000. Part of requirement to affirmatively further fair housing under the Fair Housing Act (42 U.S.C. 3601-20). <i>CDBG Matrix Code: 21D Fair Housing Activities (subject to 20% Admin. Cap). Eligibility 24 CFR Part 570.206(c).</i>	\$152,000 CDBG \$45,474 HOME
Acquisition	<u>Beyond Shelter, Inc.</u> : Budget \$345,000. Acquisition for affordable housing development. <i>National Objective: Low-Mod Housing Benefit [24 CFR Part 570.208(a)(3)]. CDBG Matrix Code: 01 Acquisition of Real Property. Eligibility 24 CFR Part 570.201(a).</i> <u>Youthworks</u> : Budget \$350,000. Acquisition for a homeless youth runaway shelter (adds 2 homeless beds in Fargo). <i>National Objective: Low-Mod Clientele Benefit [24 CFR Part 570.208(a)(2)]. CDBG Matrix Code: 03C Homeless Facilities (not operating costs). Eligibility 24 CFR Part 570.201(c).</i>	\$695,000 CDBG
Affordable Housing Development	Activities resulting in affordable housing may include acquisition, demolition, rehabilitation, or relocation in partnership with Habitat for Humanity or other similar housing organizations. Funds for this activity would be reallocated from the Slum & Blight Abatement/Hazardous Property Clearance activity budget (\$620,585 reduced to \$370,585). For more information, see Summary of Proposed Amendments in this notice. <i>National Objective: Low-Mod Housing Benefit [24 CFR Part 570.208(a)(3)]. Associated CDBG Matrix Codes include: 01 Acquisition; 02 Disposition of Real Property; 04 Clearance and Demolition; 08 Relocation; most 14 rehabilitation codes including A, B, C, D, F, G, H, and I. Associated eligibility categories include: 24 CFR Part 570.201(a), (b), (d) and/or (i); 24 CFR Part 570.202(a)(1-5) and/or (f).</i>	\$284,049 CDBG
Public Services (Homelessness Prevention & Direct Care)	<u>Gladys Ray Shelter Homeless Initiatives</u> : Budget \$19,000. Operational support (e.g., homeless initiatives, outreach, harm reduction, etc.) <i>For both activities – National Objective: Low-Mod Clientele Benefit [24 CFR Part 570.208(a)(2)]. CDBG Matrix Code: 03T Operating Costs of Homeless/Aids Patient Programs. Eligibility 24 CFR Part 570.201(e).</i> <u>FM Coalition to End Homelessness</u> : Budget \$30,000. Operational support (e.g., homelessness prevention, coordinated entry, data collection, research, etc.).	\$49,000 CDBG
Housing Rehabilitation Loan Program (6 projects + emergency projects)	Citywide housing rehabilitation program assisting owner-occupants of single-family homes whose income falls below 80% of area median income, based upon income, assets, and family size. Homes must be at least 40 years old and have a value of less than \$175,000. Funds are provided in the form of a 0% interest, deferred payment loan up to \$25,000. The assistance must be repaid upon sale, title transfer, or owner vacancy of the	\$180,000 HOME

	property within 10-years of the mortgage date, following a 4-10 year forgiveness schedule. Applications from interested individuals are accepted by the City on a first come, first served basis with priority for life and major health safety emergencies. Emergency-related improvements may be done immediately based on inspection (e.g., furnace or water heater failure, major leaks or flooding, etc.). <i>National Objective: Low-Mod Housing Benefit [24 CFR Part 570.208(3)]. Eligibility 24 CFR 92.254(b)(1) and (2).</i>	
Community Development Housing Organization (CHDO) Project	HOME "set-aside" funds used for construction of affordable housing.	\$100,000 HOME
Affordable Senior Housing Development	Increase affordable senior housing within Fargo city limits (1-3 projects). Activities resulting in affordable housing may include acquisition, demolition, rehabilitation, or relocation in partnership with local housing developers (public or private).	\$697,826 HOME
Contingency Funds	Funds held in contingency for issues that may arise during the program year.	\$10,000 CDBG \$10,000 HOME

Contingency Provisions/Potential Adjustments to 2019 Activities & Budget:

- Budget adjustments transferring amounts greater than \$50,000 are considered substantial amendments and will be implemented in accordance with Fargo's Citizen Participation Plan
- Unanticipated program income may result in a substantial amendment to amend activities and budgets in accordance with Fargo's Citizen Participation Plan
- To match actual 2019 allocation amounts, any increase or decrease in funding will be applied to the Affordable Housing Development or Home Rehabilitation activities
- All funding levels indicated above are estimated amounts

Summary of Proposed Amendments

A. Amendments to 2018 Annual Action Plan

- 1. Canceled Activities:** Funds from canceled activities are reallocated to activities as described above in this notice.
 - **Special Assessments Assistance Program: \$15,000 budget (CDBG)**
Due to a City of Fargo Administration determination, this program was funded with non-CDBG dollars.
 - **Rape and Abuse Crisis Center Public Facilities Improvements Project: \$15,000 budget (CDBG)**
CDBG funds were designated to support a facility upgrade at the Rape and Abuse Crisis Center. Due to changes in the agency's needs from the time of application, the Rape and Abuse Crisis Center has declined the 2018 Annual Action Plan award.
- 2. Revised Activity**
 - **Slum & Blight Abatement/Hazardous Property Clearance: -\$250,000 budget (CDBG)**
This amendment to the 2018 Annual Action Plan would reduce the budget for the Slum & Blight Abatement/Hazardous Property Clearance activity by \$250,000 to be redirected to Affordable Housing Development project(s) within the 2019 Annual Action Plan. Amendment would revise 2018 Annual Action Plan.

B. Amendments to 5-Year Consolidated Plan

- 1. New Activity:**
 - **Affordable Housing Development: +\$284,049 budget (CDBG)**
This amendment to the 2015-2019 5-Year Consolidated Plan would create an Affordable Housing Development activity. This new activity will be funded with redirected dollars from the above-mentioned 2018 Annual Action Plan Slum & Blight Abatement/Hazardous Property Clearance activity.

PUBLISHED
5/13/19
FORUM

Comments & Suggestions

Comments and suggestions from the public are encouraged through a public comment period and/or at the public hearing (schedule below). The 2019 draft plan and activity amendment are available online at www.fargond.gov/planninganddevelopment/plansandstudies or by request through the Planning and Development Department. See contact information below.

The facility is accessible and can accommodate persons with disabilities. Alternative formats of this information or reasonable accommodations for persons with disabilities or limited English proficiency, including the availability of interpretation and translation services, will be made upon request (48 hours notice is required). Anyone who requires these services or an auxiliary aid to fully participate in the hearing should contact the Planning and Development Department at 701.241.1474/Planning@FargoND.gov, or the City of Fargo's Section 504/ADA Coordinator Brock Morrison at 701.476.4144 to arrange for services. To access TDD/Relay service dial 701.241.8258. It is the policy of the City of Fargo to provide services without regard to race, color, religion, sex, disability, familial status, national origin, age, marital status, veteran status, sexual orientation, gender identity, public assistance, domestic violence, lawful activity, or condition protected by applicable federal and state laws except where a Bona Fide Occupational Qualification (BFOQ) applies. The City is an equal employment/equal housing opportunity agency.

30-Day Public Comment period: May 13 through June 12, 2019

Send written comments or phone: City of Fargo
Planning and Development Department
Attn: Community Development Planning Coordinator
225 4th Street North, Fargo ND 58102
701.476.4144

Electronic Comments: planning@FargoND.gov

Public Hearing: Monday, May 20, 2019 - 5:15 pm
Fargo City Commission Chambers
225 4th Street North, Fargo, ND 58102

Final City Commission Consideration: Monday, June 17, 2019 – 5:15 pm

PUBLISHED
5/13/19
FORUM



14

MEMORANDUM

TO: BOARD OF CITY COMMISSIONERS

FROM: JIM GILMOUR, STRATEGIC PLANNING DIRECTOR 

DATE: JUNE 12, 2019

SUBJECT: CHANGE ORDER FOR PARKING FACILITY RESTORATION

Western Specialty Contractors has completed restoration on three parking facilities in downtown Fargo. The Engineer for the project has determined the final quantities for the project and final costs are based on those quantities.

Attached is a change order from Western Specialty Contractors to decrease the cost of the contract by \$9,801.00.

RECOMMENDED MOTION: Approve the Change Order #3 with Western Specialty Contractors to balance quantities and decrease the contract by \$9,801.00.

Attachment

AIA® Document G701™ – 2001

Change Order

PROJECT <i>(Name and address):</i> City of Fargo Parking Structures, Civic Center Ramp, GTC Parking Garage, Island Park Ramp	CHANGE ORDER NUMBER: 003 DATE: June 10, 2019	OWNER: <input type="checkbox"/> ARCHITECT: <input type="checkbox"/> CONTRACTOR: <input type="checkbox"/> FIELD: <input type="checkbox"/> OTHER: <input type="checkbox"/>
TO CONTRACTOR <i>(Name and address):</i> Western Specialty Contractor 111 Lowry Ave., NE Minneapolis, MN 55418	ARCHITECT'S PROJECT NUMBER: 2418 3164.00 CONTRACT DATE: August 6, 2018 CONTRACT FOR: General Construction	

THE CONTRACT IS CHANGED AS FOLLOWS:

(Include, where applicable, any undisputed amount attributable to previously executed Construction Change Directives)
 Balancing work item quantities to complete project. See attached adjusted schedule of values

The original Contract Sum was	\$ 486,077.00
The net change by previously authorized Change Orders	\$ 79,966.40
The Contract Sum prior to this Change Order was	\$ 566,043.40
The Contract Sum will be decreased by this Change Order in the amount of	\$ 9,801.00
The new Contract Sum including this Change Order will be	\$ 556,242.40

The Contract Time will be unchanged by zero (0) days.

The date of Substantial Completion as of the date of this Change Order therefore is October 23, 2018

NOTE: This Change Order does not include changes in the Contract Sum, Contract Time or Guaranteed Maximum Price which have been authorized by Construction Change Directive until the cost and time have been agreed upon by both the Owner and Contractor, in which case a Change Order is executed to supersede the Construction Change Directive.

NOT VALID UNTIL SIGNED BY THE ARCHITECT, CONTRACTOR AND OWNER.

Wantman Group Inc.	Western Specialty Contractors	City of Fargo
ARCHITECT <i>(Firm name)</i>	CONTRACTOR <i>(Firm name)</i>	OWNER <i>(Firm name)</i>
8910 Purdue Rd S #400, Indianapolis 46268	ADDRESS	ADDRESS
	BY <i>(Signature)</i>	BY <i>(Signature)</i>
Paul Just	<i>(Typed name)</i>	<i>(Typed name)</i>
6/10/2019	DATE	DATE

REPORT OF ACTION

(15)

UTILITY COMMITTEE

Project No. WA1863 Type: AE2S Task Order #21 – LSWTP
Disinfection Improvements

Location: Existing Water Treatment Plant (435 14th Avenue South)

Date of Hearing: 6/6/2019

<u>Routing</u>	<u>Date</u>
City Commission	6/17/2019
Project File	

Troy Hall, Water Utility Director, presented the attached proposed AE2S task order to improve Lime Softening Water Treatment Plant (LSWTP) disinfection credit to meet EPA requirements. This additional disinfection credit is the outcome of source water monitoring completed from 2015-2017. According to a draft Planning and Preliminary Design report, an Ultraviolet (UV) treatment system installed for LSWTP would provide the most cost effective solution to reliably meet the new EPA requirements. The results of this task order will be the Final Design and Bidding of an Ultraviolet (UV) treatment system for the LSWTP to meet EPA requirements.

Water Utility staff suggests that the following scope of service for Task Order #21 is important for successful design and bidding of an Ultraviolet (UV) disinfection treatment system for the LSWTP:

<u>Phase</u>	<u>Task Number and Task Name</u>	<u>Est. Hours</u>	<u>Amount</u>
Phase 031	Additional Preliminary Design Phase Services		
	01 Project Management and Administration	88	\$ 13,500
	02 30% Percent Design Submittal	102	\$ 16,900
Phase 040	Final Design Phase Services		
	01 Project Management and Administration	250	\$ 37,100
	02 Process Design	880	\$134,600
	03 Structural Design	160	\$ 22,300
	04 Electrical Design	320	\$ 50,000
Phase 050	Bidding or Negotiating Phase Services		
	01 Pre-Bidding Administration	260	\$ 36,600
	02 Post-Bidding Administration	40	\$ 4,300
	Total	2,100	\$315,300

Water Utility staff recommends funding the Ultraviolet (UV) treatment system through a State Revolving Fund (SRF) loan. This SRF loan is already approved with Ultraviolet (UV) treatment as a listed item. Ultraviolet (UV) treatment installation is the Water Utility financial model and a line item in the 2019 Water Utility budget.

MOTION:

On a motion by Scott Liudahl, seconded by Ben Dow, the Utility Committee voted to approve the proposed Task Order #21 with AE2S in the amount of \$315,300 for Final Design and Bidding or

Ultraviolet (UV) treatment installation at the lime softening water treatment plant.

<u>COMMITTEE:</u>	<u>Present</u>	<u>Yes</u>	<u>No</u>	<u>Unanimous</u>
				<u>X</u>
				<u>Proxy</u>
Anthony Gehrig, City Commissioner				
Kent Costin, Director of Finance				
Brian Ward, Water Plant Supt.	X			
Mark Miller, Wastewater Plant Supt.	X			
Bruce Grubb, City Administrator	X			
Scott Liudahl, City Forester	X			
Terry Ludlum, Solid Waste Utility Director	X			
James Hausauer, Wastewater Util. Director	X			
Troy Hall, Water Utility Director	X			
Ben Dow, Public Works Operations Director	X			
Brenda Derrig, City Engineer	X			

ATTEST:



Troy B. Hall
Water Utility Director

C: Tim Mahoney, Mayor
Commissioner Strand
Commissioner Piepkorn
Commissioner Grindberg



June 6, 2019

Troy B. Hall
Fargo Water Utility Director
435 14th Avenue South
Fargo, ND 58102

**RE: Fargo LSWTP Crypto Compliance Improvements
Design and Bidding Phase Services
Water Consulting Task Order No. 21**

Dear Troy:

Thank you for the opportunity to submit this letter proposal for professional engineering services for the Fargo LSWTP Crypto Compliance Improvements. This letter and the attached Water Consulting Task Order No. 21 provide the proposed scope of services for additional preliminary design, final design, and bidding phase services. The proposed fee for the design and bidding phase services is \$315,300.

The City of Fargo owns and operates a 30 million gallon per day (mgd) Lime Softening Water Treatment Plant (LSWTP) and is nearing the completion of a 15 mgd Membrane Water Treatment Plant (MWTP) expansion. Fargo utilizes both the Red River and the Sheyenne River as primary water supply sources and as a result, is required to comply with the Environmental Protection Agency's Long Term 2 Surface Water Treatment Rule (LT2SWTR), which establishes treatment requirements to reduce illnesses caused by pathogens in drinking water. Recent water source monitoring has placed the Fargo WTP in a new bin classification (bin 2), which requires an additional 1-log removal credit for *Cryptosporidium* (*Crypto*). While the MWTP will meet and exceed all *Crypto* inactivation/removal requirements, additional improvements are required at the LSWTP to achieve compliance.

Under a previous Task Order, AE2S evaluated *Crypto* inactivation/removal alternatives for the Fargo LSWTP to comply with the additional requirements set forth in the LT2SWTR and identified ultraviolet inactivation (UV) as the recommended treatment alternative. This Task Order provides for services to design and bid the necessary improvements to construct a UV *Crypto* treatment system at the Fargo LSWTP.

If you agree with the proposed scope of services and associated professional fees presented in the attached Water Consulting Task Order No. 21, please sign both copies in the spaces provided, retain one fully-executed copy for your records, and return the other fully-executed copy to AE2S. We are excited to assist the City of Fargo in completing this water treatment project.

Submitted in Service,

A handwritten signature in blue ink, appearing to read "Jacob D. Strombeck", is written over a horizontal line.

Jacob D. Strombeck
Project Manager

Enclosures

This is Water Consulting Task Order No. 21, consisting of 4 pages.

Water Consulting Task Order No. 21

In accordance with Paragraph 1.01 of the Agreement Between Owner and Engineer for Professional Water Consulting Services – Task Order Edition, dated January 1, 2018 ("Agreement"), Owner and Engineer agree as follows:

1. Background Data

- A. Effective Task Order Date: June 6, 2019
- B. Owner: City of Fargo (Water Utility)
- C. Engineer: Advanced Engineering and Environmental Services, Inc. (AE2S)
- D. Engineer Project No.: P00803-2018-021
- E. Specific Project (title): Fargo LSWTP Crypto Compliance Improvements – Design and Bidding Phase Services
- F. Specific Project (description):

Recent water source monitoring has placed the Fargo Water Treatment Plant into a new bin classification within the definition of the Environmental Protection Agency's Surface Water Treatment Rule, which increases the inactivation/removal requirements for *Cryptosporidium* (*Crypto*). While the new membrane plant expansion will meet and exceed all requirements, additional inactivation/removal requirements are necessary to comply with the Long Term 2 Enhanced Surface Water Treatment Rule (LT2 ESWTR) at the existing Lime Softening Water Treatment Plant (LSWTP). The purpose of this project is to construct improvements at the Fargo LSWTP necessary to comply with the additional *Crypto* requirements set forth in the LT2 ESWTR. The services included in this Task Order include preliminary design, final design, and bidding phase services for the Project.

2. Services of Engineer

- A. The specific services to be provided or furnished by Engineer under this Task Order are detailed in Attachment 1 and include the services (and related terms and conditions) set forth in the following sections of Exhibit A, as attached to the Agreement referred to above, such sections being hereby incorporated by reference:
 - Preliminary Design Phase (Exhibit A, Paragraph A1.02)
 - Final Design Phase (Exhibit A, Paragraph A1.03)
 - Bidding or Negotiating Services (Exhibit A, Paragraph A1.04)
- B. Resident Project Representative (RPR) Services: None.
- C. All of the services included above comprise Basic Services for purposes of Engineer's compensation under this Task Order.

3. Owner's Responsibilities

Owner shall have those responsibilities set forth in Article 2, Exhibit B of the Agreement.

4. Task Order Schedule

In addition to any schedule provisions provided in Exhibit A or elsewhere, the parties shall meet the following approximate tentative schedule:

- Task Order approval (Utility Committee) – June 6, 2019
- Task Order approval (City Commission) – June 17, 2019
- Preliminary Engineering Phase – June – August 2019
- Final Design Phase – October 2019 – February 2020
- Bidding Phase – March 2020

5. Payments to Engineer

A. Owner shall pay Engineer for services rendered under this Task Order as follows:

<i>Phase</i>	<i>Task Number and Task Name</i>	<i>Payment Method</i>	<i>Estimated Hours</i>	<i>Amount</i>
031	<i>Additional Preliminary Design Phase Services</i>	<i>Method A</i>		
01	<i>Project Management and Administration</i>		88	\$13,500
02	<i>30 Percent Design Submittal</i>		102	\$16,900
040	<i>Final Design Phase Services</i>	<i>Method A</i>		
01	<i>Project Management and Administration</i>		250	\$37,100
02	<i>Process Design</i>		880	\$134,600
03	<i>Structural Design</i>		160	\$22,300
04	<i>Electrical Design</i>		320	\$50,000
050	<i>Bidding or Negotiating Phase Services</i>	<i>Method A</i>		
01	<i>Pre-Bidding Administration</i>		260	\$36,600
02	<i>Post-Bidding Administration</i>		40	\$4,300
Total			2,100	\$315,300

Compensation items and totals based in whole or in part on Hourly Rates or Direct Labor are estimates only. Lump sum amounts and estimated totals included in the breakdown by phases incorporate Engineer's labor, overhead, profit, reimbursable expenses (if any), and Consultants' charges, if any. For lump sum items, Engineer may alter the distribution of compensation between individual phases (line items) to be consistent with services actually rendered, but shall not exceed the total lump sum compensation amount unless approved in writing by the Owner.

B. The terms of payment are set forth in Article 4 of the Agreement and in the applicable governing provisions of Exhibit C, where Method A is a Lump Sum payment and Method B is payment for Standard Hourly Rates.

6. Consultants retained as of the Effective Date of the Task Order: None.

7. Other Modifications to Agreement and Exhibits: None.

8. Attachments:

Attachment 1 – Scope of Services for Task Order

9. Other Documents Incorporated by Reference:

Fargo LSWTP *Crypto* Compliance Improvements – Planning and Preliminary Design Report – Draft May 2019, prepared by AE2S.

Task Order No. 8 – Fargo LSWTP *Crypto* Compliance Improvements (Planning and Preliminary Design Report)

10. Terms and Conditions

Execution of this Task Order by Owner and Engineer shall make it subject to the terms and conditions of the Agreement (as modified above), which Agreement is incorporated by this reference. Engineer is authorized to begin performance upon its receipt of a copy of this Task Order signed by Owner.

The Effective Date of this Task Order is June 6, 2019.

OWNER: City of Fargo (Water Utility)

ENGINEER: Advanced Engineering and Environmental Services, Inc. (AE2S)

By: _____

By: _____

Name: Troy B. Hall

Name: Brian R. Bergantine, PE

Title: Water Utility Director

Title: Operations Manager

DESIGNATED REPRESENTATIVE FOR TASK ORDER:

DESIGNATED REPRESENTATIVE FOR TASK ORDER:

Name: Troy B. Hall

Name: Ben Julson, PE

Title: Water Utility Director

Title: Project Manager

Address: 435 14th Ave S
Fargo, ND 58103

Address: 4170 28th Ave S
Fargo, ND 58104

E-Mail Address: THall@FargoND.gov

E-Mail Address: Ben.Julson@ae2s.com

Phone: (701) 476 - 6741

Phone: (701) 364 - 9111

Attachment 1 to Water Consulting Task Order No. 21***Fargo LSWTP Crypto Compliance Improvements - Design and Bidding Phase Services******June 6, 2019***

Scope of Services

The City of Fargo owns and operates a 30 million gallon per day (mgd) Lime Softening Water Treatment Plant (LSWTP), and a 15 mgd Membrane Water Treatment Plant (MWTP). Fargo utilizes both the Red River and the Sheyenne River as primary water supply sources and as a result, is required to comply with the Environmental Protection Agency's Surface Water Treatment Rule, which establishes treatment requirements to reduce illnesses caused by pathogens in drinking water. Recent water source monitoring has placed the Fargo WTP in a new bin classification (Bin 2), which requires an additional 1-log removal credit for *Cryptosporidium* (*Crypto*). While the MWTP meets and exceeds all *Crypto* inactivation/removal requirements, additional improvements are required at the LSWTP to achieve compliance. This Scope of Services provides for the continuation of Preliminary Design Phase Services, Final Design Phase Services, and Bidding or Negotiation Phase Services to design and bid the ultraviolet (UV) *Crypto* treatment system at the LSWTP necessary to comply with the additional *Crypto* removal inactivation/requirements set forth in the Long Term 2 Enhanced Surface Water Treatment Rule (LT2 ESWTR). In total, the project includes the following key improvements:

- UV *Crypto* treatment system and ancillary equipment (control panels, piping, valves, etc.)
- Transfer pump upgrades and wetwell reconfiguration
- Filter effluent pH adjustment improvements
- Post-treatment chemical mixing improvements
- Powdered activated carbon (PAC) feed system demolition and basin repurposing

The following is a detailed breakdown of this Scope of Services to Water Consulting Task Order No. 21.

Phase 031 – Additional Preliminary Design Phase Services

In accordance with Paragraphs A1.02 and A1.08 of Exhibit A of the Original Task Order Agreement, dated January 1, 2018, ENGINEER shall perform the following additional Preliminary Design Phase services under Water Consulting Task Order No. 21:

Under the previous Task Order No. 8, the ENGINEER provided Phase 030 – Preliminary Design Phase Services that included compiling preliminary drawings for the UV *Crypto* treatment system to the level of detail necessary to confirm spatial requirements of the system. Under this Phase 031, ENGINEER shall continue to develop UV *Crypto* treatment system major equipment and piping drawings, and develop a Basis of Design and preliminary drawings for additional improvements identified during the Study and Report Phase, including:

- Transfer pump upgrades and wetwell reconfiguration
- Filter effluent pH adjustment improvements
- Post-treatment chemical mixing improvements
- Powdered activated carbon (PAC) feed system demolition and basin repurposing

The detailed scope of services provided under Phase 031 – Additional Preliminary Design Phase Services is provided as follows:

Task 01 – Project Management and Administration

ENGINEER shall perform general Project administration activities including progress monitoring, scheduling, general correspondence, office administration, and invoicing. These activities include maintaining contact and liaison with the OWNER and Project staff; providing OWNER with monthly Project financial status updates; ensuring that the needs of the OWNER are met in a timely manner, and monitoring Project budgets and schedules.

Task 02 – 30 Percent Design Submittal

The ENGINEER shall prepare construction drawings and technical specifications which are to address not less than 30 percent completion design effort for the Fargo LSWTP Crypto Compliance Improvements. The tasks and deliverables anticipated are as follows:

- 30 Percent Design Deliverables
 - Prepare a Basis of Design Report (BDR) that will be updated throughout this Scope of Service. The BDR shall be incorporated into the Planning and Preliminary Design Report that was developed as part of the Study and Report
 - Preliminary equipment and process layouts
 - Piping and Instrumentation Diagram (P&ID) drawings
 - Preliminary equipment descriptions
 - Preliminary specifications for major process equipment
 - Structural review
 - Opinion of probable construction cost update
 - Project schedule update
- ENGINEER shall conduct internal quality control review and refinement before submittal to OWNER.
- ENGINEER shall submit three (3) hard copies and one (1) electronic copy, in PDF format, of the 30 Percent Design deliverables to OWNER for review at least one week prior to review meeting.
- ENGINEER shall conduct a 30 Percent Design Workshop with the OWNER to obtain OWNER'S comments on the submittal.
- ENGINEER shall revise the BDR, as necessary, to reflect decisions taken at this level.

Phase 040 – Final Design Phase Services

In accordance with Paragraphs A1.03 and A1.08 of Exhibit A of the Original Task Order Agreement, dated January 1, 2018, ENGINEER shall perform the following additional Final Design Phase services under Water Consulting Task Order No. 21:

The tasks or deliverables to be provided in the Final Design Phase will expand on the preliminary design concepts prepared for the Project and result in completion of final bidding documents for Water Consulting Services Task Order No. 21. One (1) independent set of bidding documents will be prepared for the Project. Throughout the Final Design Phase, design deliverables shall be prepared in the form of the following milestones:

- 60 Percent Design Submittal

- 90 Percent Design Submittal
- 100 Percent (Final) Bid Documents

The milestone design deliverables are anticipated to include the following key components:

60 Percent Design Submittal

The 60 percent design will expand on the preliminary and 30 percent design documents. The ENGINEER shall prepare construction drawings and technical specifications which are to address not less than 60 percent completion design effort for the Fargo LSWTP Crypto Compliance Improvements. The tasks and deliverables anticipated are as follows:

- 60 Percent Design Deliverables
 - Preliminary contract front-end documents (using Engineers Joint Contract Documents Committee (EJCDC) and Construction Specification Institute (CSI) format)
 - Process and structural specifications
 - 60 percent design drawings
 - Sections and details showing major process and sub process equipment
 - Structural framing and support plans and sections
 - Major electrical cabinets and gear
 - Power and lighting plans
 - UV system control panel layout
 - Major commodity specifications and equipment schedules
- Opinion of probable construction cost update
- Project schedule update
- Basis of Design Memorandum update
- ENGINEER shall conduct internal quality control review and refinement before submittal to OWNER.
- ENGINEER shall submit three (3) hard copies and one (1) electronic copy, in PDF format, of the 60 Percent Design deliverables to OWNER for review at least one (1) week prior to review meeting.
- A 60 Percent Design Review Workshop will be conducted with key City staff, including water utility operators, to thoroughly review the 60 percent design submittal. ENGINEER shall obtain OWNER'S comments on the submittal.
- ENGINEER shall revise the Basis of Design, as necessary, to reflect decisions taken at this level.

90 Percent Design Submittal

This task will consist of the work items continue to refine the project documents towards final completion. The OWNER's comments obtained during review of the 60 percent design documents will be incorporated into the design documents. ENGINEER shall refine the drawings, details, notes, and appurtenances during this task and the specifications will be completed in greater detail. ENGINEER shall submit the 90 percent design documents to the OWNER'S key project stakeholders for review. The tasks and deliverables anticipated are as follows:

- Final review set of contract drawings, which will now include:
 - Finalized contract front-end documents
 - All remaining discipline schedules and details
 - Electrical and Instrumentation and Controls (I&C) design details
- Final review set of technical specifications and construction contract documents, which shall include electrical and I&C specifications.

- Opinion of probable construction cost update.
- Project schedule update.
- ENGINEER shall conduct internal quality control review and refinement before submittal to OWNER.
- ENGINEER shall submit three (3) hard copies and one (1) electronic copy, in PDF format, of the 90 Percent Design deliverables to OWNER for review at least one week prior to review meeting.
- A design review workshop will be conducted with key City staff, including water utility operators to thoroughly review the 90 percent design submittal.
- ENGINEER shall refine documents according to mutual agreement between OWNER and ENGINEER.

100 Percent Bidding Document Submittal

These submittals will be used as the bidding documents and include or address 90 percent review comments, as appropriate. ENGINEER shall prepare and submit an electronic copy (PDF) and three (3) sets of final 100 Percent Bidding Documents the OWNER for review. ENGINEER shall also submit three (3) copies of the Bidding Documents to the North Dakota Department of Environmental Quality (NDDEQ) for review and approval. One (1) approved copy will be retained by the NDDEQ, one (1) approved copy will be retained by the OWNER, and one (1) approved copy will be retained by the ENGINEER. ENGINEER shall meet with the OWNER to discuss review comments, if any, from the regulatory agencies. The 100 Percent Bidding Documents deliverables are as follows:

- Final review set of drawings for the Fargo LSWTP Crypto Compliance Improvements, signed and sealed as appropriate.
- Final review set of technical specifications and construction contract documents for the Fargo LSWTP Crypto Compliance Improvements, signed and sealed as appropriate.
- Final opinion of probable construction cost update.
- Final updates to the Basis of Design. ENGINEER will provide OWNER with three (3) copies of the final Preliminary Planning and Design Report, which shall include the Basis of Design for all major project components.

For presentation of scope of services, the Fargo LSWTP Crypto Compliance Improvements Final Design Phase will be split into the following Tasks: (1) Project Management and Administration, (2) Process Design, (3) Structural Design, and (4) Electrical Design.

Task 01 – Project Management and Administration

ENGINEER shall perform general Project administration activities including progress monitoring, scheduling, general correspondence, office administration, and invoicing. These activities include maintaining contact and liaison with the OWNER and Project staff; providing OWNER with monthly Project financial status updates; ensuring that the needs of the OWNER are met in a timely manner, and monitoring Project budgets and schedules.

Task 02 – Process Design

Services to be provided under this Task shall include the tasks and deliverables as detailed in the milestone deliverable descriptions. More specifically, the Process Design is anticipated to include the following key components:

- UV *Crypto* treatment system:
 - UV vendor correspondence and equipment procurement (if determined necessary due to spatial restrictions and/or schedule constraints)
 - Process piping, flow control valves, and flow meters
 - UV reactors and associated control system
 - Off-spec recycle back to transfer pump wetwell
- Transfer pump system modifications:
 - Relocation of existing transfer pump to open pump bay
 - Modifications to common transfer pump 42-inch discharge piping
 - Evaluation and potential replacement of or modifications to existing transfer pumps to increase pumping capacity
 - Modifications to wetwell to improve hydraulic connection
 - Modifications to backwash supply line and valves to ensure off-spec water is not conveyed to the clearwell during filter backwashes
- Filter effluent pH adjustment improvements:
 - Sodium hydroxide chemical feed system sizing; metering pumps and storage
 - Sodium hydroxide chemical pump skid design
 - Chemical piping and injectors
- Post-treatment chemical mixing improvements:
 - Evaluate in-line and sampling line mixing options to improve mixing and dosing of chlorine and ammonia in finished water transfer line
- PAC system:
 - Demolition and repurposing of the existing PAC feed system and slurry storage basins

Task 03 – Structural Design

Services to be provided under this Task shall include the tasks and deliverables as detailed in the milestone deliverable descriptions. More specifically, the Structural Design is anticipated to include the following key components:

- Process piping and equipment support system
- Transfer pump floor modifications
- Grated system (floor, stairs, elevated platform, and railing) for accessing process equipment
- Transfer pump wetwell separation wall modifications

Task 04 – Electrical Design

Services to be provided under this Task shall include the tasks and deliverables as detailed in the milestone deliverable descriptions. More specifically, the Electrical Design is anticipated to include the following key components:

- Power and controls to UV system reactors, chemical feed systems, control panels, and other associated ancillary equipment
- Upgrades to existing transfer pump motor control centers and starters as necessary (to be determined during Phase 031)
- Integration of UV system and chemical systems into WTP Supervisory Control and Data Acquisition (SCADA) system
- UV system standalone uninterruptible power supply (UPS) if determined necessary by the NDDEQ
- Integration of UV system into existing WTP backup power generation system

Phase 050 – Bidding or Negotiating Phase Services

In accordance with Paragraphs A1.04 and A1.08 of Exhibit A of the Original Task Order Agreement, dated January 1, 2018, ENGINEER shall perform the following additional Bidding or Negotiating Phase services under Water Consulting Task Order No. 21:

Task 01 – Pre-Bidding Administration

Pre-bidding administration services will be provided to assist the OWNER in soliciting bids for construction, responding to plan holder questions, preparing and certifying addenda for distribution, and attending the bid opening for the Fargo LSWTP Crypto Compliance Improvements

Task 02 – Post-Bidding Administration

Post-bidding administration services will include reviewing the bids for errors and discrepancies, preparing a recommendation letter to the Utility Committee and City Commission, preparing the Notice of Award(s) to the successful contractor(s), and preparing the contract documents for the Fargo LSWTP Crypto Compliance Improvements.

REPORT OF ACTION

16

UTILITY COMMITTEE

Project No. SW 16-03 Phase II

Type: Change Orders – SW16-03 Phase II
Landfill Gas Expansion Project

Location: Solid Waste Division - Landfill

Date of Hearing: 6/6/19

<u>Routing</u>	<u>Date</u>
City Commission	6/17/19
Project File	

Terry Ludlum, Solid Waste Utility Director, presented the attached Change Orders for SW16-03 Phase II Landfill Gas Expansion Project.

On October 8, 2018, the Commission approved the award of Project SW16-03 Phase II in a *Multiple Prime Contractor* format. The landfill gas expansion project was awarded to *Gast Construction Company Inc., Robert Gibb & Sons, and Rickard Electric Inc.* Construction on the project began in October (2018) and is scheduled for completion and startup in July of 2019. Awarded contract bid prices, change orders, and adjusted contract prices are as follows:

Contractor	Contractor	Contract Price	Current Change Orders	Adjusted Contract Price
Gast Construction Co.	General Contractor (GC)	\$605,276.89	\$4,225.27	\$609,502.16
Robert Gibb & Sons	Mechanical Contractor (MC)	\$707,744.00	\$21,532	\$729,276.00
Rickard Electric	Electrical Contractor (EC)	\$535,740.07	\$3,470	\$539,210.07
		\$1,848,760.96	\$29,227.27	\$1,877,988.23

A detailed summary of each contractor recommended change order has been included in the memorandum to the Utility Committee for your review.

MOTION:

On a motion by Ben Dow, seconded by Brian Ward, the Utility Committee voted to approve the attached Change Orders for SW16-03 Phase II, Landfill Gas Compressor Station Expansion Project.

<u>COMMITTEE:</u>	<u>Present</u>	<u>Yes</u>	<u>No</u>	<u>Unanimous</u>
Anthony Gehrig, City Commissioner				X
Brenda Derrig, City Engineer	X	X		
Kent Costin, Director of Finance				
Brian Ward, Water Plant Supt.	X	X		
Mark Miller, Wastewater Plant Supt.	X	X		
Bruce Grubb, Enterprise Director	X	X		
Scott Liudahl, City Forester	X	X		
Terry Ludlum, Solid Waste Utility Director	X	X		
James Hausauer, Wastewater Util. Director	X	X		
Troy Hall, Water Utility Director	X	X		
Ben Dow, Public Works Operations Director	X	X		

ATTEST:



 Terry Ludlum
 Solid Waste Utility Director

C: Tim Mahoney, Mayor
 Commissioner Grindberg
 Commissioner Piepkorn
 Commissioner Strand



Division of Solid Waste

2301 8th Avenue North
 Fargo, North Dakota 58102
 Phone: 701-241-1449
 Fax: 701-241-8109

MEMORANDUM

To: Utility Committee

From: Terry Ludlum, Solid Waste Utility Director 

Date: May 31, 2019

Subject: Change Orders – SW 16-03 Phase II Landfill Gas Expansion Project

On October 8, 2018, the Commission approved the award of Project SW16-03 Phase II in a *Multiple Prime Contractor* format. The landfill gas expansion project was awarded to *Gast Construction Company Inc.*, *Robert Gibb & Sons*, and *Rickard Electric Inc.* Construction on the project began in October 2018, and is scheduled for completion and startup June 2019. Awarded contract bid prices are as follows:

Contract	Contractor	Bid Price
General Contractor (GC)	Gast Construction Co.	\$580,322.00
Mechanical Contractor (MC)	Robert Gibb & Sons	\$699,950.00
Electrical Contractor (EC)	Rickard Electric	\$534,830.00
	Total	\$1,815,102.00

With previous Change Order approval, the current contract amounts would be as follows:

Contract	Contractor	Bid Price
General Contractor (GC)	Gast Construction Co.	\$605,276.89
Mechanical Contractor	Robert Gibb & Sons	\$707,744.00
Electrical Contractor	Rickard Electric	\$535,740.07
	Total	\$1,848,760.96

The following table shows the overall cost summary of the recommended changes by the contractors during this approval period (monthly):

Change Order	Contractor	Change Order Cost
GC – No. 4	Gast Construction	\$4,225.27
MC – No. 6	Robert Gibb & Sons	\$13,394.00
MC – No. 7	Robert Gibb & Sons	\$5,019.00
MC – No. 8	Robert Gibb & Sons	\$1,341.00
MC – No. 9	Robert Gibb & Sons	\$1,778.00
EC – No. 4	Rickard Electric	\$1,075.00
EC – No. 5	Rickard Electric	\$2,395.00
	Total	\$29,227.27

With Change Order approval, the updated contract amounts would be as follows:

Contract	Contractor	Bid Price
General Contractor (GC)	Gast Construction Co.	\$609,502.16
Mechanical Contractor	Robert Gibb & Sons	\$729,276.00
Electrical Contractor	Rickard Electric	\$539,210.07
	Total	\$1,877,988.23

To date, change orders have totaled 3.5 % of total construction costs.

Detailed Summary of Change Orders

The project cost impact due to **General Contractor** recommended changes are as follow:

- No. 4:** Contractor asked to extend the Fire Riser / Compressor Room approximately 6'-6" due to maintenance restrictions recognized as air compressor and dryer equipment installed. Original plans showed equipment mounted on platforms, recognized that ongoing maintenance would be difficult to perform given the projected height. Room redesigned to place all equipment at floor level.
Cost: \$4,225.27 (Based on time & material.)

Reason: City requested

The project cost impact due to **Mechanical Contractor** recommended changes are as follow:

- No. 6:** Contractor asked to furnish and install compressed air driven condensate drain devise for all applicable pieces of landfill gas treatment equipment. Moisture separators originally designed to be maintained manually, modified design will allow for an automated control valve and actuator that opens on each piece of equipment when the high level switch is activated. Allows for moisture separator system and moisture removal pieces of equipment to be maintained automatically or remotely, which is consistent with the overall design and operational plan.

Cost: \$13,394.00

Reason: City requested.

- No. 7:** Contractor asked to delete fiberglass insulation and aluminum jacketing for the valves, flame arrestors, and flanges for outdoor piping and install removable insulation jackets for the same.

Cost: \$5,019.00

Reason: City requested.

- No. 8:** Contractor asked to furnish and install a 4-inch check valve in the discharge line of the existing Compressor #3 to prevent backflow. Was outside of original system design.

Cost: \$1,341.00

Reason: City requested

No. 9: Contractor asked to furnish and install isolation valve and underground copper line from propane tank discharge line to flare, per City Building Code

Cost: \$1,778.00

Reason: Building Code requirement

The project cost impact due to **Electrical Contractor** recommended changes are as follow:

No. 4: Contractor asked to furnish and install 110 VAC, single-phase power to existing valve building used to control flow to Cargill. Includes electric service cable and buried conduit.

Cost: \$1,075.00

Reason: City requested.

The project cost impact due to **Electrical Contractor** recommended changes are as follow:

No. 5: Contractor asked to furnish and install three-phase power to existing leachate pump lift stations located west of the compressor station. The purpose of the installation was the necessary upgrade of an existing electrical service. Includes electric service cable and buried conduit.

Cost: \$2,395.00

Reason: City requested.

Process for Amending the Contract Documents; Changes in the Work

As provided in **Article 11** of **Project SW16-03 Specifications**, and to avoid substantial construction schedule delays, *Work Change Directives (WCD)* were issued for the additional work. Acceptance of *WCDs* by Solid Waste (City) staff are provided after review and negotiation of contractor recommended work through contractor provided *Proposal Requests*. *WCDs* have been incorporated into subsequent *Change Orders* through formal Utility Committee and City Commission approval on this project.

Recommendation

Approve the contract *Change Orders* with Gast Construction (General Contractor), Robert Gibb & Sons (Mechanical Contractor), and Rickard Electric (Electrical Contractor) on Project SW16-03 Phase II Landfill Gas Expansion Project.

Date of Issuance: May 23, 2019	Effective Date: May 23, 2019
Owner: City of Fargo Division of Solid Waste	Owner's Contract No.: SW 16-03
Contractor: Gast Construction	Contractor's Project No.:
Engineer: Wenck Associates Inc.	Engineer's Project No.: 0208-0140
Project: Landfill Gas Compression System Expansion	Contract Name:

The Contract is modified as follows upon execution of this Change Order:

Description: Extend the Fire Riser/Compressor Room on the north side of the building approximately 6'-6" to the west. The scope of work for this change included the following:

- Remove existing gypsum board from the west wall of the room
- Support the existing ceiling of the room
- Remove the west wall of the room
- Furnish and install double 2" by 6" header from south wall of the room to the north wall at the location of the removed wall
- Install two 5/8" thick gypsum board panel on the ceiling and including a 2" by 4" stud between the gypsum board panels
- Furnish and install foamed in-place insulation system on the new ceiling area.
- Install 5/8" thick gypsum board on the inside and outside of the walls
- Mud and tape the new walls and ceiling
- Apply coatings to the new wall as surfaces in accordance with the contract documents

A conceptual plan of the room extension is attached to this change order.

This change order will be paid by the City of Fargo on a time and materials basis not to exceed \$4,225.27. The City will pay Gast Construction for the costs for materials, labor, and subcontractors fees required to perform the work will be in accordance with the Gast Proposal Request for Change Order No. 4 provided by Gast and attached to this change order. Gast shall submit time records and receipts to document the actual work performed.

CHANGE IN CONTRACT PRICE	CHANGE IN CONTRACT TIMES
Original Contract Price: \$ <u>580,322.00</u>	Original Contract Times: Substantial Completion: <u>June 30, 2019</u> Ready for Final Payment: _____ days or dates
[Increase] [Decrease] from previously approved Change Orders No. <u>0</u> to No. <u>3</u> : \$ <u>24,954.89</u>	[Increase] [Decrease] from previously approved Change Orders No. ___ to No. ___: Substantial Completion: <u>No Change</u> Ready for Final Payment: _____ days
Contract Price prior to this Change Order: \$ <u>605,276.89</u>	Contract Times prior to this Change Order: Substantial Completion: <u>June 30, 2019</u> Ready for Final Payment: _____ days or dates
[Increase] [Decrease] of this Change Order: \$ <u>4,225.27</u>	[Increase] [Decrease] of this Change Order: Substantial Completion: <u>No Change</u> Ready for Final Payment: <u>No Change</u> days or dates

Contract Price incorporating this Change Order: \$ <u>609,502.16</u>	Contract Times with all approved Change Orders: Substantial Completion: <u>No Change</u> Ready for Final Payment: <u>No Change</u> days or dates
---	---

RECOMMENDED:		ACCEPTED:		ACCEPTED:	
By: _____	By: _____	By: _____	By: _____	By: _____	By: _____
<u><i>M. W. Dady</i></u>				<u><i>Coely M. Hester</i></u>	
Engineer (if required)	Owner (Authorized Signature)			Contractor (Authorized Signature)	
Title: <u>Project Manager</u>	Title _____	Title _____	Title <u>Project Manager</u>	Title _____	Title _____
Date: <u>May 23, 2019</u>	Date _____	Date _____	Date <u>5/28/2019</u>	Date _____	Date _____

Approved by Funding Agency (if applicable)

By: _____ Date: _____
Title: _____



PROPOSAL REQUEST

Date: 4/19/2019 **Project:** Landfill Gas Compression Building
To: Wenck **Location:** Fargo, ND
Attn: Mark Deady **Architects PR #:**
Address: Fargo, ND **Description:** Add on to the riser room approx. 6.5'to the west.

Please review the following proposal.

Gast Construction:			
Add 6.5' of space to the riser room to the west			
Category	MH	Rate	Total
Materials	1	\$ 354.58	\$ 354.58
Labor	42	\$ 60.00	\$ 2,520.00
Misc. Consumables	1	\$ 60.00	\$ 60.00
Subtotal			\$ 2,934.58
OH/P	15%		\$ 440.19
Total #1			\$ 3,374.77

Subcontractor / Supplier:	
Foam Doctors	
Tony Eckert & Sons	
Quote	Total
Foam Doctors	\$ 535.00
T. Eckert and Sons	\$ 275.00
Subtotal	
	\$ 810.00
OH/P	5%
	\$ 40.50
Total #2	
	\$ 850.50

Total #1 \$ 3,374.77
Total #2 \$ 850.50

Grand Total for Proposal: \$ 4,225.27

From: Cody McLaren
 Project Manager

Acceptance Signature: _____
 Title: _____
 Owner/Architect: _____
 Date: _____

CC:



MENARDS - FARGO
1300 13th Avenue East
West Fargo, ND 58078

KEEP YOUR RECEIPT
 RETURN POLICY VARIES BY PRODUCT TYPE

Unless noted below allowable returns for items on this receipt will be in the form of an in store credit voucher if the return is done after 08/04/19

If you have questions regarding the charges on your receipt, please email us at:
 FARGfrontend@menards.com



Sale Transaction

Cust name: Gast Construction Co Inc
 3" EXT DECK 6 LOBE
 2303515 23.48
 ORDER 38848
 2X4-10' STUD/#2&BTR SPF -PICK
 1021114 24 @3.59 86.16
 2X6-8' STUD/#2&BTR SPF -PICK
 1021758 10 @4.99 49.90
 5/8X4X12 GYPS TYPE X -PICK
 1311303 7 @14.23 99.61
 R11 3.5X15X40' UNFACED -PICK
 1616020 9.49
 END OF ORDER

TOTAL 268.64
 TAX WEST FARGO-ND 7.5% 20.15
 TOTAL SALE 288.79
 Menard Contractor Card 2116 288.79
 060505

Swiped
 Job # or Name : landfill

TOTAL NUMBER OF ITEMS = 43

GUEST COPY

The Cardholder acknowledges receipt of goods/services in the total amount shown hereon and agrees to pay the card issuer according to its current terms.

THIS IS YOUR CREDIT CARD SALES SLIP
 PLEASE RETAIN FOR YOUR RECORDS.

Now Hiring!

Extra \$3/HR on Weekends

Please Apply in Person

at Menards.com/ND



MENARDS - FARGO
1300 13th Avenue East
West Fargo, ND 58078

KEEP YOUR RECEIPT
 RETURN POLICY VARIES BY PRODUCT TYPE

Unless noted below allowable returns for items on this receipt will be in the form of an in store credit voucher if the return is done after 08/05/19

If you have questions regarding the charges on your receipt, please email us at:
 FARGfrontend@menards.com



Sale Transaction

ORDER	38947	
5/8X4X12 GYPS TYPE X	-PICK	
1311303	4 @14.23	56.92
END OF ORDER		

TOTAL	56.92
TAX WEST FARGO-ND 7.5%	4.27
TOTAL SALE	61.19
Menard Contractor Card 2116	61.19

012970
 Swiped
 Job # or Name : landfill

TOTAL NUMBER OF ITEMS = 4

GUEST COPY

The Cardholder acknowledges receipt of goods/services in the total amount shown hereon and agrees to pay the card issuer according to its current terms.

THIS IS YOUR CREDIT CARD SALES SLIP
 PLEASE RETAIN FOR YOUR RECORDS.

Now Hiring!

Extra \$3/HR on Weekends

Please Apply in Person

or at Menards.com/Careers

THANK YOU, YOUR CASHIER, Edith

40466 07 3616 05/07/19 06:15AM 3036

Landfill Tand M

LOVE'S HOME CENTERS, LLC
5001 13TH AVE S
FARGO, ND 58103 (701) 433-2160

- SALE -

SALES#: S1650SS0 1944044 TRANS#: 10236206 05-07-19

10351 1LB DRYWALL NAIL COATED 1	4.20
SUBTOTAL: 4.20	
TAX: 0.32	
INVOICE 10308 TOTAL:	4.60
VISA:	4.60

VISA:XXXXXXXXXX0836 AMOUNT:4.60 AUTHCD:007783
CHIP REFID:165010159018 05/07/19 08:36:42
CUSTOMER CODE: landf111
APL: Visa Credit TUR: 0080008000
ATD: A000000031010 TSI: F800
STORE: 1650 TERMINAL: 10 05/07/19 08:37:08

OF ITEMS PURCHASED: 1
EXCLUDES FEES, SERVICES AND SPECIAL ORDER ITEMS



THANK YOU FOR SHOPPING LOVE'S.
SEE REVERSE SIDE FOR RETURN POLICY.
STORE MANAGER: JEN SCHUK

LOVE'S PRICE MATCH GUARANTEE
FOR MORE DETAILS, VISIT LOWES.COM/PRICEMATCH

* YOUR OPINIONS COUNT! *
* REGISTER FOR A CHANCE TO BE *
* ONE OF FIVE \$300 WINNERS DRAWN MONTHLY! *
* (REGISTRESE EN EL SORTEO MENSUAL *
* PARA SER UNO DE LOS CINCO GANADORES DE \$300! *
* REGISTER BY COMPLETING A GUEST SATISFACTION SURVEY *
* WITHIN ONE WEEK AT: www.lowes.com/survey *
* Y O U R I D # 10308 1650 127 *
* NO PURCHASE NECESSARY TO ENTER OR WIN. *
* VOID WHERE PROHIBITED. MUST BE 18 OR OLDER TO ENTER. *
* OFFICIAL RULES & WINNERS AT: www.lowes.com/survey *

STORE: 1650 TERMINAL: 10 05/07/19 08:37:08

The Foam Doctor's LLC
 3237 4th Ave S Suite 1
 Fargo, ND 58103
 701-526-1100

BID PROPOSAL

DATE	BID #
4/19/2019	3899

TO:
Gast Construction 3410 39th St S Fargo, ND 58104

TERMS
Due upon job completion

DESCRIPTION
<p>THE AREA FIGURED IS THE NEW CEILING AND TOUCHING UP WHERE THE OLD WALL IS REMOVED AND THE NEW WALL CONSTRUCTED (ALONG THE NORTH WALL) ON THE FARGO LANDFILL GAS PROJECT AS CALLED OUT IN SKETCH SK-05. IT IS ALL REGARDING THE ADDITION TO THE RISER ROOM.</p> <ol style="list-style-type: none"> 1. Furnish and install a 2" (R-13) closed cell foam to the new ceiling area and foam as needed to patch the walls areas. 2. Furnish and install DC315 to the foam as a thermal barrier. 3. Furnish and install a paint to match the existing finish. 4. The owner has the area cleaned out as needed. 5. The price includes all material and labor to complete the job. 6. The quote is good for 45 days. 7. This would take a portion of 2 days to complete.

Past due accounts will be charged a finance charge of 1.5% per month or 18% annually.	Total	\$535.00
---	--------------	----------

Owner or Buyer	SIGNED	 The Foam Doctor's LLC
----------------	---------------	--



P.O. Box 948 Fargo, ND 58107

Ph. 701-282-9225

Fax 701-277-1964

Gast Construction
P.O. Box 833
Wahpeton, ND 58074

April 18, 2019

Attention: Cody

PROJECT: Landfill Gas Compression

SECTION(S) BIDDING: Prime and Paint Additional Footage in Riser Room.

BASE BID: \$275.00.

ADDENDUM(S): None.

ALTERNATE(S): None.

All Prices are Valid for 30 Days and are FOB Jobsite: Labor, Materials, and Sales Tax Complete.

Scott Eckert
Cell 701-367-6822

Date of Issuance: April 23, 2019	Effective Date: April 23, 2019
Owner: City of Fargo Division of Solid Waste	Owner's Contract No.: SW 16-03
Contractor: Robert Gibb & Sons	Contractor's Project No.:
Engineer: Wenck Associates Inc.	Engineer's Project No.: 0208-0140
Project: Landfill Gas Compression System Expansion	Contract Name:

The Contract is modified as follows upon execution of this Change Order:

Description: Contractor shall furnish and install compressed air driven condensate drain devices for Moisture Separators V-114, V-118, and V-128. The condensate drain device is referred to as a WaterHog by the equipment manufacturer. Contractor shall furnish and install a Vacuum Handler condensate drain device for moisture separator V-101. Contractor shall furnish and install piping from the moisture separators to the condensate drain devices. Contractor shall provide manual bypass drains for Moisture Separators V-114, V-118, and V-128. Contractor shall incorporate the air diaphragm pump procured under the original scope of this contract into the manual drain system for Moisture Separator V-101. All drains systems shall be plumbed to the facility floor drains with pressure rated hose. Contractor shall provide compressed air lines to the WaterHogs and Vacuum Handler devices. Moisture Separator FLT-600 located on the Siloxane Removal Skid is equipped with an automatic control valve and actuator that opens when the high level switch in the moisture separator is activated. This drain will be connected to pressure-rated hose and routed to the nearest floor drain.

A scope of work, conceptual sketches, cost estimate, and WaterHog and Vacuum Handler quotes was prepared by Robert Gibb & Sons to describe the work. This information received from Robert Gibb & Sons is attached.

CHANGE IN CONTRACT PRICE	CHANGE IN CONTRACT TIMES
Original Contract Price: \$ <u>699,950.00</u>	Original Contract Times: Substantial Completion: <u>June 30, 2019</u> Ready for Final Payment: _____ days or dates
[Increase] [Decrease] from previously approved Change Orders No. <u>0</u> to No. <u>5</u> : \$ <u>7,794.00</u>	[Increase] [Decrease] from previously approved Change Orders No. ___ to No. ___ : Substantial Completion: <u>No Change</u> Ready for Final Payment: _____ days
Contract Price prior to this Change Order: \$ <u>707,744.00</u>	Contract Times prior to this Change Order: Substantial Completion: <u>June 30, 2019</u> Ready for Final Payment: _____ days or dates
[Increase] [Decrease] of this Change Order: \$ <u>13,394.00</u>	[Increase] [Decrease] of this Change Order: Substantial Completion: <u>No Change</u> Ready for Final Payment: <u>No Change</u> days or dates
Contract Price incorporating this Change Order: \$ <u>721,138.00</u>	Contract Times with all approved Change Orders: Substantial Completion: <u>No Change</u> Ready for Final Payment: <u>No Change</u> days or dates

RECOMMENDED:		ACCEPTED:		ACCEPTED:	
By:		By:		By:	
	Engineer (if required)		Owner (Authorized Signature)		Contractor (Authorized Signature)
Title:	Project Manager	Title		Title	Estimator/Project Manager
Date:	April 23, 2019	Date		Date	4/23/2019

Approved by Funding Agency (if applicable)

By: _____ Date: _____
Title: _____



2011 Great Northern Drive
Fargo, ND 58102
Phone: 701.282.5900
Fax: 701.281.0819

Automatic Drain Line Scope of Work

1. Providing 3 Waterhogs, 1 for the moisture separator V-114 and 2 for the exchanger skid moisture separators V-118 and V-128
2. Provide manual drains options for the moisture separator V-114 and for the exchanger skid moisture separators V-118 and V-128, see sketch for details
3. Provide a Vacuum Handler for the compressor skid moisture separator V-101, see sketch for details
4. Provide a manual drain for the compressor skid via the Sand Piper pump and manual valves, see sketch for details
5. Provide connections directly to the under slab PVC drainage system with pressure rated hose, see sketch for sizes
6. Providing compressed airlines to Waterhogs and the Vacuum Handler - run ½" ridged close to the connection point, install an isolation valve and then run tubing for the final connection
7. Drain connection points will be made to try and maintain roughly 4" of water in the bottom of the knock out tanks. This should allow sediment to settle to the bottom of the tank. The thought process behind this is creating an automated drain system that is as problem free as possible. It would be recommended that the manual drains be operated periodically to blowdown any sediment that might accumulate in the tanks. See sketch for details.
8. The moisture separator (FLT-600) drain line for the Siloxane removal skid appears to be equipped with a control valve and actuator that will open when the high level switch is activated in the moisture separator vessel. This drain line will be connected to a pressure rated hose that will be routed overhead either to the drain near Compressor #3 or the drain on the west side of the building near the heat exchanger skid (whichever is closest).

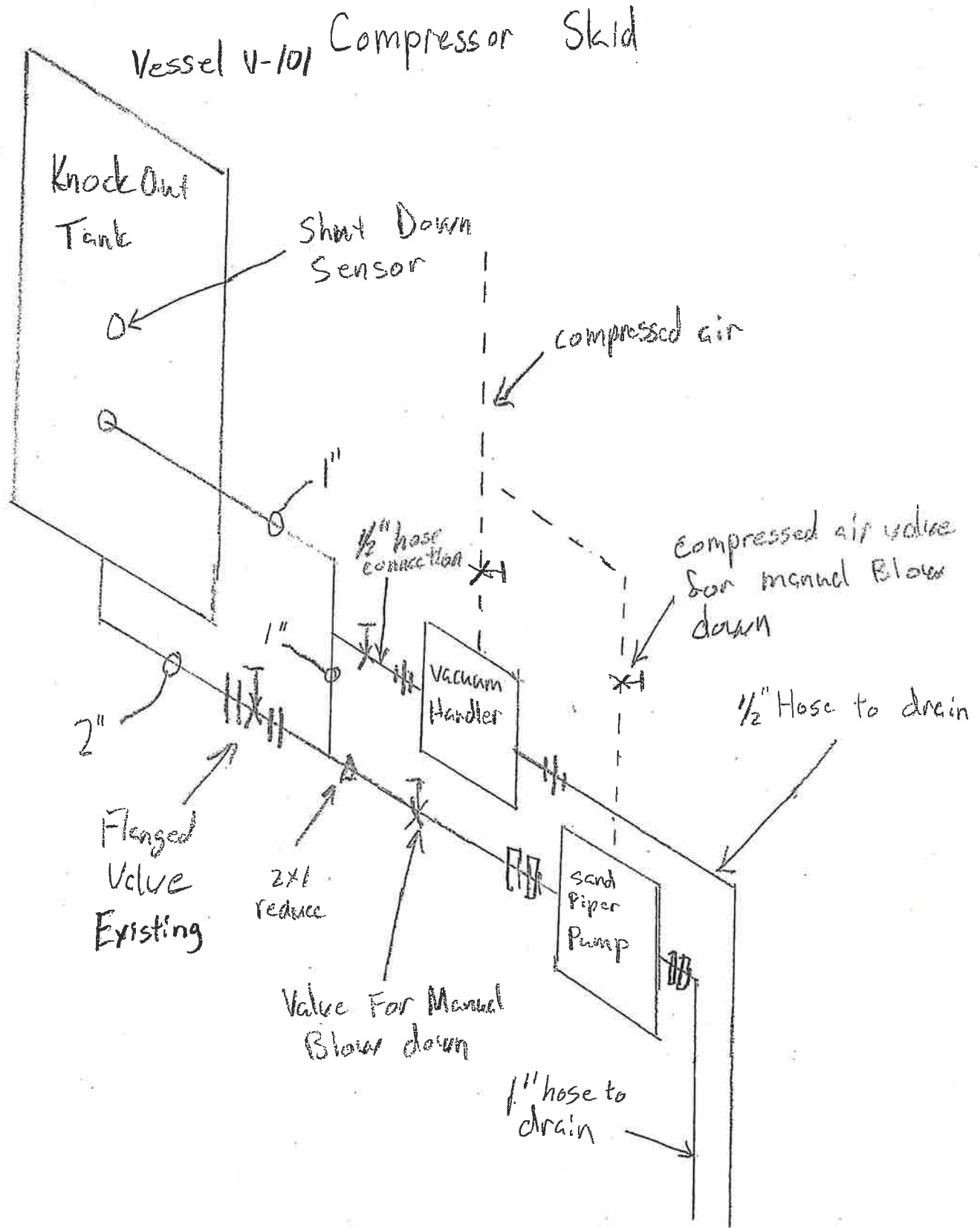

Exchanger Skid & Moisture Separator

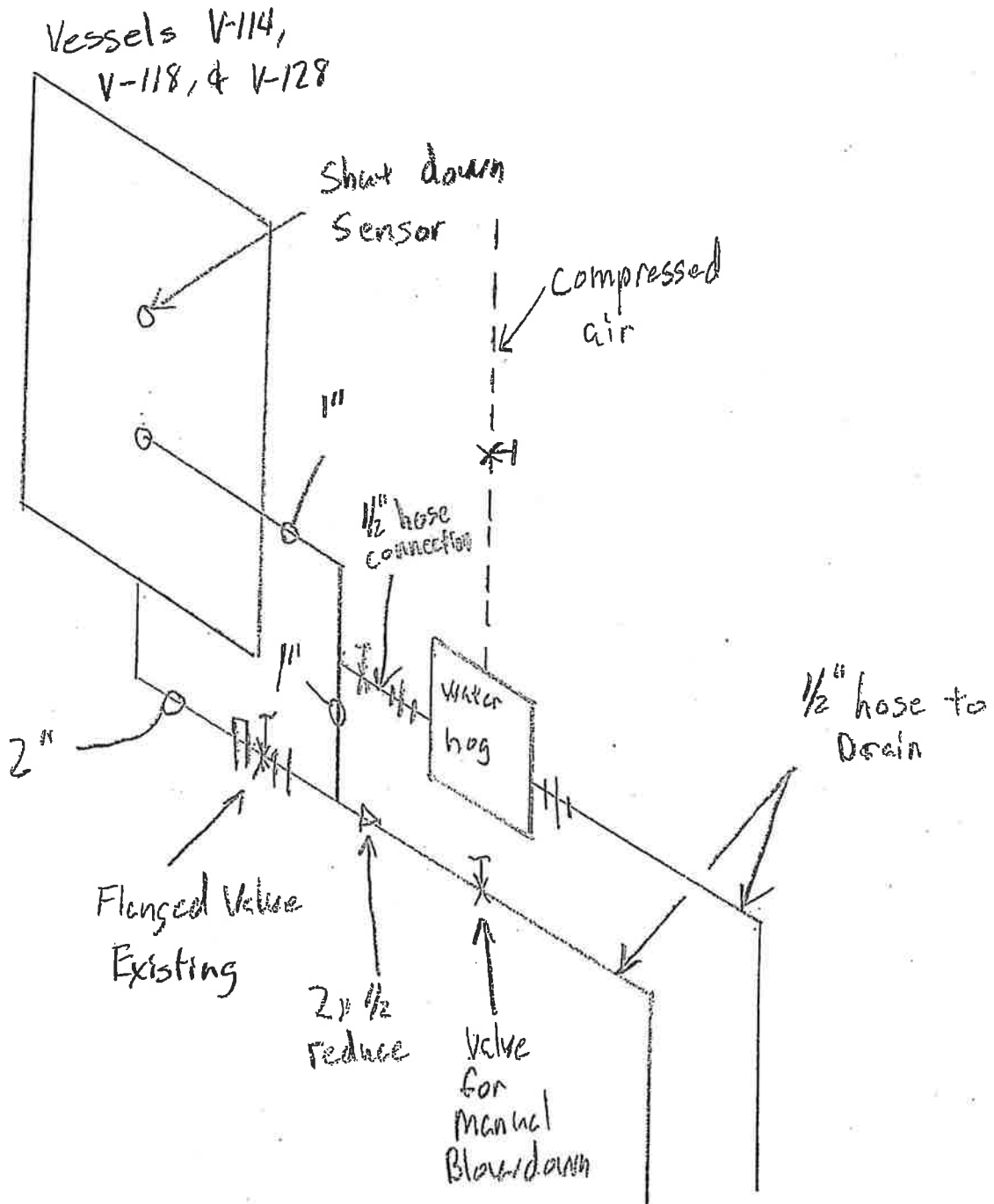



205 40th Street Southwest
PO Box 10188 (58106)
Fargo, North Dakota 58103
Phone: 701.282.5900
Fax: 701.281.0819

April 10, 2019

Mr. Randy Hanson
Project Manager
Wenck
1800 Pioneer Creek Center
Maple Plain, MN 55359

RE: Fargo Landfill Gas Compression System Expansion, Project NO. SW-16-03
Revised Piping for Drain Lines

Dear Randy,

Please find list below our cost associated with revising the drain lines on compressor 1 & 2 skid, the exchange skid and the moisture separator to provide automatic drains vs manual drains.

Material:

Pipe and Fittings Drain Lines:	\$ 1,097
Pipe and Fittings Air lines:	\$ 325
Drain Hoses:	\$ 601
Water Hogs and Vacuum Handler:	\$ 1,984
Miscellaneous Hardware:	\$ 200
Deduct for Drain Line Material Provided in Base Bid:	(\$ 323)

Tax: \$ 291

Labor:

Automated Installation:	\$ 8,823
Deduct for Drain Line Installation Provided in Base Bid:	<u>(\$ 822)</u>

Sub Total: \$ 12,176

Overhead/Profit \$ 1,218

Total: \$ 13,394

If you have any questions please feel free to contact our office at 701.282.5900.

Sincerely,
ROBERT GIBB & SONS

Tim Singelmann

Tim Singelmann



QUOTATION

Bill To:
 Dakota Fluid Power, Inc.
 2210 W Main Ave
 West Fargo, ND 58078
 US

Sales Location:
 Fargo

Order Number	
1744567	
Order Date	Page
4/10/2019 09:11:43	1 of 2

Quote Expires On 5/10/2019

Bill To:
 ROBERT GIBB & SON'S INC
 2011 GREAT NORTHERN DRIVE
 FARGO, ND 58102

Ship To:
 ROBERT GIBB & SON'S INC
 2011 GREAT NORTHERN DRIVE
 FARGO, ND 58102

Ship To Phone: 701-282-5900

Customer ID: 120860

PO Number	Required Date	Carrier Code	Taker / Salesman
DRAIN HOSE	4/10/2019	WILL ADVISE	DANIEL.HOLZHEIMER

Quantities					Item ID Item Description	Pricing UOM Unit Size	Unit Price	Extended Price
Ordered	Allocated	Remaining	UOM Unit Size	Disp.				

Order Note: 4-5 DAY LEAD TIME, FOB-POINT OF ORIGIN

100.00	0.00	100.00	FT		OH2486000	FT	2.1500	215.00
				1.0	8-LOLA 1/2IN LOL-PLUS(BLACK)	1.0		
<i>Ordered As:</i> LOLA								
3.00	0.00	3.00	EA		GA1609000	EA	64.9300	194.79
				1.0	16GMV Gates hose assembly 12" OAL 16GMV/ 16MP-16MP	1.0		
<i>Ordered As:</i> 16GMV								
22.00	0.00	22.00	EA		32-017	EA	2.3600	51.92
				1.0	1/2" x 1/2" brass barb x npt	1.0		
22.00	0.00	22.00	EA		32-510	EA	0.5171	11.38
				1.0	BRASS FERRULE	1.0		
1.00	0.00	1.00	EA		DFP ASSBY KIT	EA	127.7167	127.72
				1.0	DFP ASSEMBLED KIT	1.0		

Total Lines: 5

SUB-TOTAL: 600.81
TAX: 0.00
AMOUNT DUE: 600.81
 U.S. Dollars

ALL SALES SUBJECT TO OUR TERMS AND CONDITIONS LOCATED AT:
www.dakotafluidpower.com/terms-and-conditions



QUOTATION

Bill To:
 Dakota Fluid Power, Inc.
 2210 W Main Ave
 West Fargo, ND 58078
 US

Sales Location:
 Fargo

Order Number	
1743450	
Order Date	Page
4/5/2019 12:03:26	1 of 2

Quote Expires On 5/5/2019

Bill To:
 ROBERT GIBB & SON'S INC
 2011 GREAT NORTHERN DRIVE
 FARGO, ND 58102

Ship To:
 ROBERT GIBB & SON'S INC
 2011 GREAT NORTHERN DRIVE
 FARGO, ND 58102

Ship To Phone: 701-282-5900

Customer ID: 120860

PO Number	Required Date	Carrier Code	Taker / Salesman
FARGO LANDFILL	4/5/2019	WILL ADVISE	DANIEL.HOLZHEIMER

Quantities					Item ID Item Description	Pricing UOM Unit Size	Unit Price	Extended Price
Ordered	Allocated	Remaining	UOM Unit Size	Disp.				

Order Note: 6-8 DAY LEAD TIME, FOB-POINT OF ORIGIN

3.00	0.00	3.00	EA		LH50-0LAAA	EA	250.1374	750.41
				1.0	WATERHOG CONDENSATE TRAP	1.0		
					• POWERS THROUGH CONDENSATE BUILDUP			
					Ideal for compressor applications up to 100 hp. The WaterHog™ design avoids small passages			
					common on competitor designs, ensuring clog-free operation.			
					• Fully AUTOMATIC operation. No timer or manual settings.			
1.00	0.00	1.00	EA		UH50-0LD1	EA	1,233.4286	1,233.43
				1.0	VACUUM HANDLER PD1	1.0		

Total Lines: 2

SUB-TOTAL: 1,983.84
TAX: 0.00
AMOUNT DUE: 1,983.84
 U.S. Dollars

ALL SALES SUBJECT TO OUR TERMS AND CONDITIONS LOCATED AT:
www.dakotafluidpower.com/terms-and-conditions

Date of Issuance: April 30, 2019	Effective Date: April 30, 2019
Owner: City of Fargo Division of Solid Waste	Owner's Contract No.: SW 16-03
Contractor: Robert Gibb & Sons	Contractor's Project No.:
Engineer: Wenck Associates Inc.	Engineer's Project No.: 0208-0140
Project: Landfill Gas Compression System Expansion	Contract Name:

The Contract is modified as follows upon execution of this Change Order:

Description: Contractor shall delete the fiberglass insulation and aluminum jacketing for the valves, flame arrestors, and the flanges for the outdoor piping from its scope of work and install removeable insulation jackets for the valves, flame arrestors, and flanges.

This change order shall include all labor and materials required to for the installation of the removeable insulation jackets for the valves, flame arrestors, and flanges.

The quote provided by Robert Gibb & Sons is attached to this change order.

CHANGE IN CONTRACT PRICE	CHANGE IN CONTRACT TIMES
Original Contract Price: \$ <u>699,950.00</u>	Original Contract Times: Substantial Completion: <u>June 30, 2019</u> Ready for Final Payment: _____ days or dates
[Increase] [Decrease] from previously approved Change Orders No. <u>0</u> to No. <u>6</u> : \$ <u>21,188.00</u>	[Increase] [Decrease] from previously approved Change Orders No. ___ to No. ___ : Substantial Completion: <u>No Change</u> Ready for Final Payment: _____ days
Contract Price prior to this Change Order: \$ <u>721,138.00</u>	Contract Times prior to this Change Order: Substantial Completion: <u>June 30, 2019</u> Ready for Final Payment: _____ days or dates
[Increase] [Decrease] of this Change Order: \$ <u>5,019.00</u>	[Increase] [Decrease] of this Change Order: Substantial Completion: <u>No Change</u> Ready for Final Payment: <u>No Change</u> days or dates
Contract Price incorporating this Change Order: \$ <u>726,157.00</u>	Contract Times with all approved Change Orders: Substantial Completion: <u>No Change</u> Ready for Final Payment: <u>No Change</u> days or dates

RECOMMENDED:	ACCEPTED:	ACCEPTED:
By: <u><i>Matt Doady</i></u>	By: _____	By: <u><i>Tom Singhman</i></u>
Engineer (if required)	Owner (Authorized Signature)	Contractor (Authorized Signature)
Title: <u>Project Manager</u>	Title _____	Title <u>Estimator/Project Manager</u>
Date: <u>April 30, 2019</u>	Date _____	Date <u>4-30-2019</u>

Approved by Funding Agency (if applicable)

By: _____ Date: _____
Title: _____



205 40th Street Southwest
PO Box 10188 (58106)
Fargo, North Dakota 58103
Phone: 701.282.5900
Fax: 701.281.0819

April 30, 2019

Mr. Randy Hanson
Project Manager
Wenck
1800 Pioneer Creek Center
Maple Plain, MN 55359

RE: Fargo Landfill Gas Compression System Expansion, Project NO. SW-16-03
Revised Insulation

Dear Randy,

Please find list below our cost associated with providing removable blanket insulation on flanges, valves and the flame arrestors vs fiberglass insulation and aluminum jacketing.

Material:

Removable blankets:	\$ 7,190
Credit for base bid insulation:	(\$2,410)
Sub Total:	\$ 4,780
Subcontractor Overhead/Profit	\$ 239
Total:	<u>\$ 5,019</u>

If you have any questions please feel free to contact our office at 701.282.5900.

Sincerely,
ROBERT GIBB & SONS

Tim Singelmann

Tim Singelmann

Date of Issuance: May 16, 2019	Effective Date: May 16, 2019
Owner: City of Fargo Division of Solid Waste	Owner's Contract No.: SW 16-03
Contractor: Robert Gibb & Sons	Contractor's Project No.:
Engineer: Wenck Associates Inc.	Engineer's Project No.: 0208-0140
Project: Landfill Gas Compression System Expansion	Contract Name:

The Contract is modified as follows upon execution of this Change Order:

Description: Contractor shall furnish and install a 4-inch diameter wafer style check valve in the discharge line (LFG-108-4"-1S4) from the existing Compressor #3. The check Valve shall be installed downstream of the installed butterfly valve V-14002. Installation of the check valve will require cutting into the discharge line and installing two flanges and gaskets.

The proposal estimate provided by Robert Gibb & Sons for this work is attached to this change order.

CHANGE IN CONTRACT PRICE	CHANGE IN CONTRACT TIMES
Original Contract Price: \$ <u>699,950.00</u>	Original Contract Times: Substantial Completion: <u>June 30, 2019</u> Ready for Final Payment: _____ days or dates
[Increase] [Decrease] from previously approved Change Orders No. <u>0</u> to No. <u>7</u> : \$ <u>26,207.00</u>	[Increase] [Decrease] from previously approved Change Orders No. <u> </u> to No. <u> </u> : Substantial Completion: <u>No Change</u> Ready for Final Payment: _____ days
Contract Price prior to this Change Order: \$ <u>726,157.00</u>	Contract Times prior to this Change Order: Substantial Completion: <u>June 30, 2019</u> Ready for Final Payment: _____ days or dates
[Increase] [Decrease] of this Change Order: \$ <u>1,341.00</u>	[Increase] [Decrease] of this Change Order: Substantial Completion: <u>No Change</u> Ready for Final Payment: <u>No Change</u> days or dates
Contract Price incorporating this Change Order: \$ <u>727,498.00</u>	Contract Times with all approved Change Orders: Substantial Completion: <u>No Change</u> Ready for Final Payment: <u>No Change</u> days or dates

RECOMMENDED:	ACCEPTED:	ACCEPTED:
By: <u><i>Matt Dady</i></u>	By: _____	By: <u><i>Tom Singelman</i></u>
Engineer (if required)	Owner (Authorized Signature)	Contractor (Authorized Signature)
Title: <u>Project Manager</u>	Title _____	Title <u>Estimator/Project Manager</u>
Date: <u>May 16, 2019</u>	Date _____	Date <u>May 17, 2019</u>

Approved by Funding Agency (if applicable)

By: _____ Date: _____
Title: _____



205 40th Street Southwest
PO Box 10188 (58106)
Fargo, North Dakota 58103
Phone: 701.282.5900
Fax: 701.281.0819

May 8, 2019

Mr. Randy Hanson
Project Manager
Wenck
1800 Pioneer Creek Center
Maple Plain, MN 55359

RE: Fargo Landfill Gas Compression System Expansion, Project NO. SW-16-03
Check Valve Compressor 3

Dear Randy,

Please find list below our cost associated with installing a 4" check valve on the number 3 compressor gas discharge line.

Material:		
	Fittings & Check Valve:	\$ 483
	Tax:	\$ 36
Labor:		<u>\$ 700</u>
	Sub Total:	\$ 1,219
	Overhead/Profit	\$ 122
	Total:	<u>\$ 1,341</u>

If you have any questions please feel free to contact our office at 701.282.5900.

Sincerely,
ROBERT GIBB & SONS

Tim Singelmann
Tim Singelmann



Check Valve



We offer our wafer check valves in 3" through 10". These lightweight aluminum valves are designed for installation between two flanges in vertical or horizontal piping systems. For use in the pneumatic and bulk material handling industries to stop flow reversal in air and gas applications. Features a balanced disc where only 33% of the disc area is unbalanced. This is considerably less than conventional check valves. This feature tends to reduce back-flow and eliminate slamming (a major factor in valve failure), and permits the disc to open with a minimum of pressure differential.

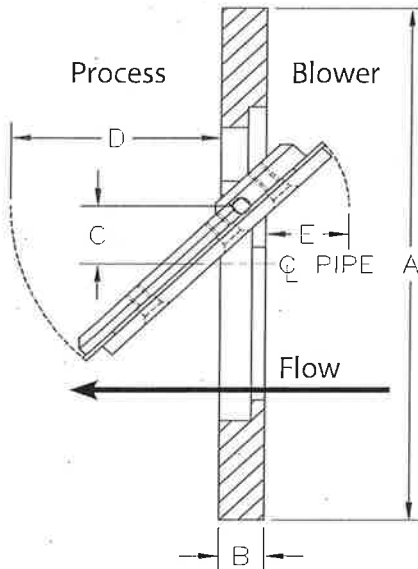
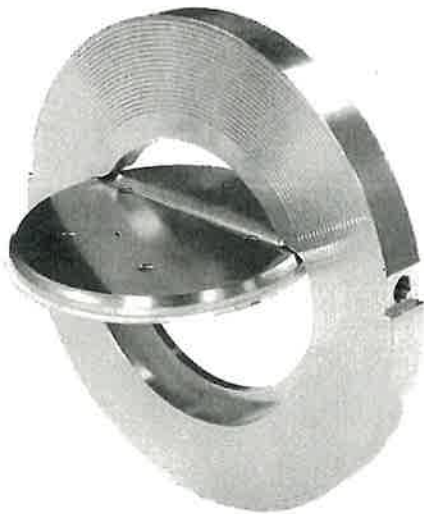

Approximate Dimensions in Inches

Valve Size	A	B	C	D	E
3"	5-3/8	5/8	9/16	1-5/8	3/8
4"	6-7/8	5/8	3/4	2-1/4	5/8
5"	7-3/4	5/8	7/8	2-7/8	1-1/8
6"	8-3/4	5/8	1-1/8	3-5/8	1-5/16
8"	11	3/4	1-3/8	4-1/2	2
10"	13-3/8	3/4	1-1/2	5-3/4	2-7/8

Features Include:

- **Minimum Pressure Drop**
Maximum flow due to the low profile, aerodynamic disc design;
- **Fast Delivery**
Immediate shipment from our large in-house STOCK;
- **Simple Design**
Only one moving part ensures long, trouble-free service;
- **One Piece thru Stem**
Stainless steel for strength and durability;
- **Low Maintenance Cost**
Seat is easily replaced;
- **Stem Bushings**
Teflon for an extended service life; rated to +500°F;
- **Aluminum Body and Disc**
Lightweight for easy installation. High strength aluminum alloy for strength and extended service life;
- **Teflon Seal**
Seal and stem bushings are standard with Teflon for a long service life;
- **Wafer Design**
Fits between 150# flanges. Minimal space required for lightweight piping applications.



**Pathfinder Systems Swing Check Valve
Pressure Drop versus Flow (SCFM)**

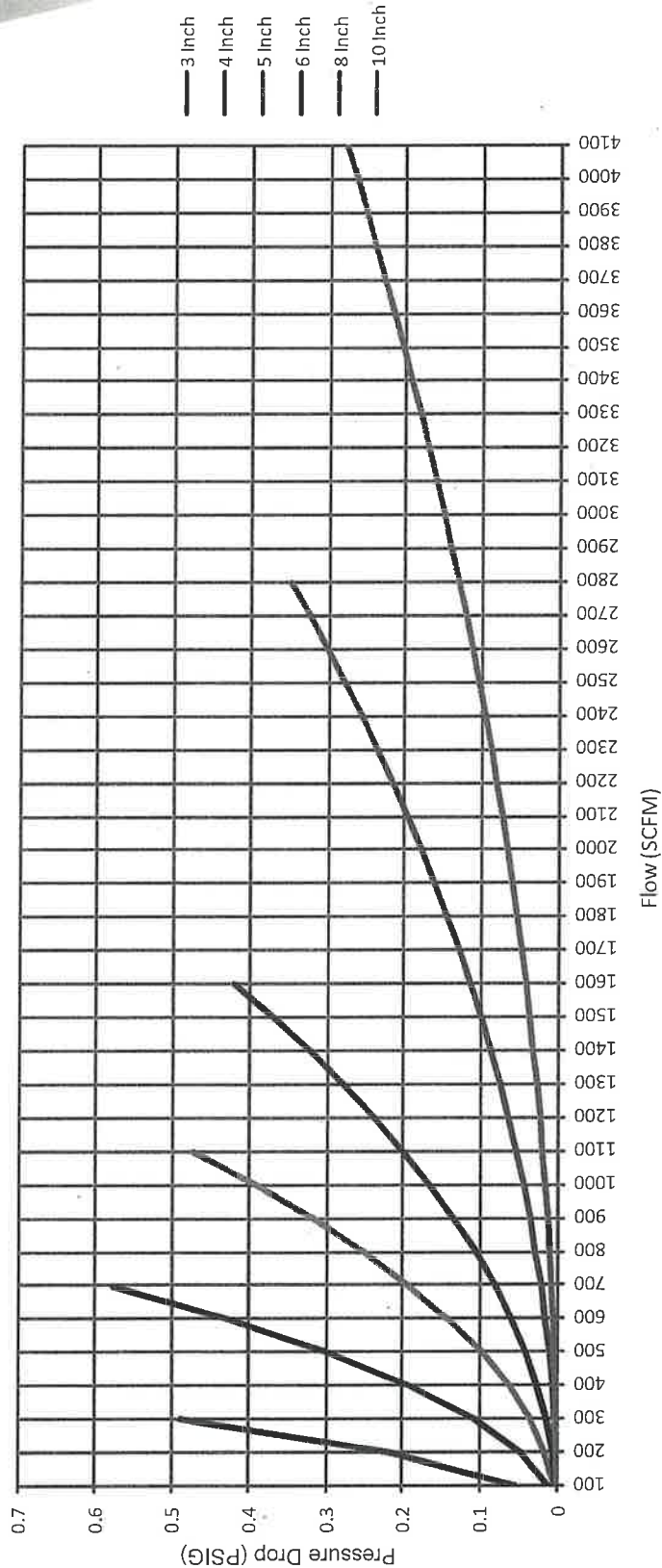

Date of Issuance: May 16, 2019	Effective Date: May 16, 2019
Owner: City of Fargo Division of Solid Waste	Owner's Contract No.: SW 16-03
Contractor: Robert Gibb & Sons	Contractor's Project No.:
Engineer: Wenck Associates Inc.	Engineer's Project No.: 0208-0140
Project: Landfill Gas Compression System Expansion	Contract Name:

The Contract is modified as follows upon execution of this Change Order:

Description: Contractor shall furnish and installing an isolation valve on the propane tank discharge line and installing a 1/2-inch diameter copper pipe line underground from the propane tank discharge line isolation valve to the flare spool piece provided by John Zink that includes a pressure regulator, solenoid valve, and pressure indicator. The contractor will install a pipeline from the Zink-provided spool piece to the flare ignitor under the existing contract.

The propane storage tank, discharge piping, pressure regulator, and other equipment associated with the propane tank shall be furnished and installed by others.

The proposal estimate and approximate routing plan for the buried propane line provided by Robert Gibb & Sons for this work is attached to this change order.

CHANGE IN CONTRACT PRICE	CHANGE IN CONTRACT TIMES
Original Contract Price: \$ <u>699,950.00</u>	Original Contract Times: Substantial Completion: <u>June 30, 2019</u> Ready for Final Payment: _____ days or dates
[Increase] [Decrease] from previously approved Change Orders No. <u>0</u> to No. <u>8</u> : \$ <u>27,548.00</u>	[Increase] [Decrease] from previously approved Change Orders No. ___ to No. ___ : Substantial Completion: <u>No Change</u> Ready for Final Payment: _____ days
Contract Price prior to this Change Order: \$ <u>727,498.00</u>	Contract Times prior to this Change Order: Substantial Completion: <u>June 30, 2019</u> Ready for Final Payment: _____ days or dates
[Increase] [Decrease] of this Change Order: \$ <u>1,778.00</u>	[Increase] [Decrease] of this Change Order: Substantial Completion: <u>No Change</u> Ready for Final Payment: <u>No Change</u> days or dates
Contract Price incorporating this Change Order: \$ <u>729,276.00</u>	Contract Times with all approved Change Orders: Substantial Completion: <u>No Change</u> Ready for Final Payment: <u>No Change</u> days or dates

RECOMMENDED:		ACCEPTED:		ACCEPTED:	
By:	<u><i>M. W. D. [Signature]</i></u>	By:	<u>_____</u>	By:	<u><i>[Signature]</i></u>
	Engineer (if required)		Owner (Authorized Signature)		Contractor (Authorized Signature)
Title:	<u>Project Manager</u>	Title	<u>_____</u>	Title	<u>Estimator/Project Manager</u>
Date:	<u>May 16, 2019</u>	Date	<u>_____</u>	Date	<u>May 17, 2019</u>

Approved by Funding Agency (if applicable)

By: _____ Date: _____
Title: _____



205 40th Street Southwest
PO Box 10188 (58106)
Fargo, North Dakota 58103
Phone: 701.282.5900
Fax: 701.281.0819

May 8, 2019

Mr. Randy Hanson
Project Manager
Wenck
1800 Pioneer Creek Center
Maple Plain, MN 55359

RE: Fargo Landfill Gas Compression System Expansion, Project NO. SW-16-03
Under Ground Propane Line

Dear Randy,

Please find list below our cost associated with installing an underground propane line from the propane tank to the flare stack.

Material:		
	Pipe & Fittings:	\$ 308
	Tax:	\$ 23
	Trencher Rental:	\$ 165
	Labor:	<u>\$ 1,120</u>
	Sub Total:	\$ 1,616
	Overhead/Profit	\$ 162
	Total:	<u>\$ 1,778</u>

Note: This is based on us providing an isolation valve after the tank supplier's equipment and hooking up to the ½ copper line that will run under ground to the flare stack. No information from the tank supplier was available at the time I prepared this quote. Propane tank and equipment by others.

If you have any questions please feel free to contact our office at 701.282.5900.

Sincerely,
ROBERT GIBB & SONS

Tim Singelmann
Tim Singelmann

INSTALL 6" - 45° BEND

4" PVC WATER SERVICE
5'-0" OF BUILDING AT
LOCATION SHOWN. MIN.
7'-0" BURIAL DEPTH

FLARE FOUNDATION
SLAB EL. = 901.00

PROPANE CYLINDER
SLAB EL. = 901.00

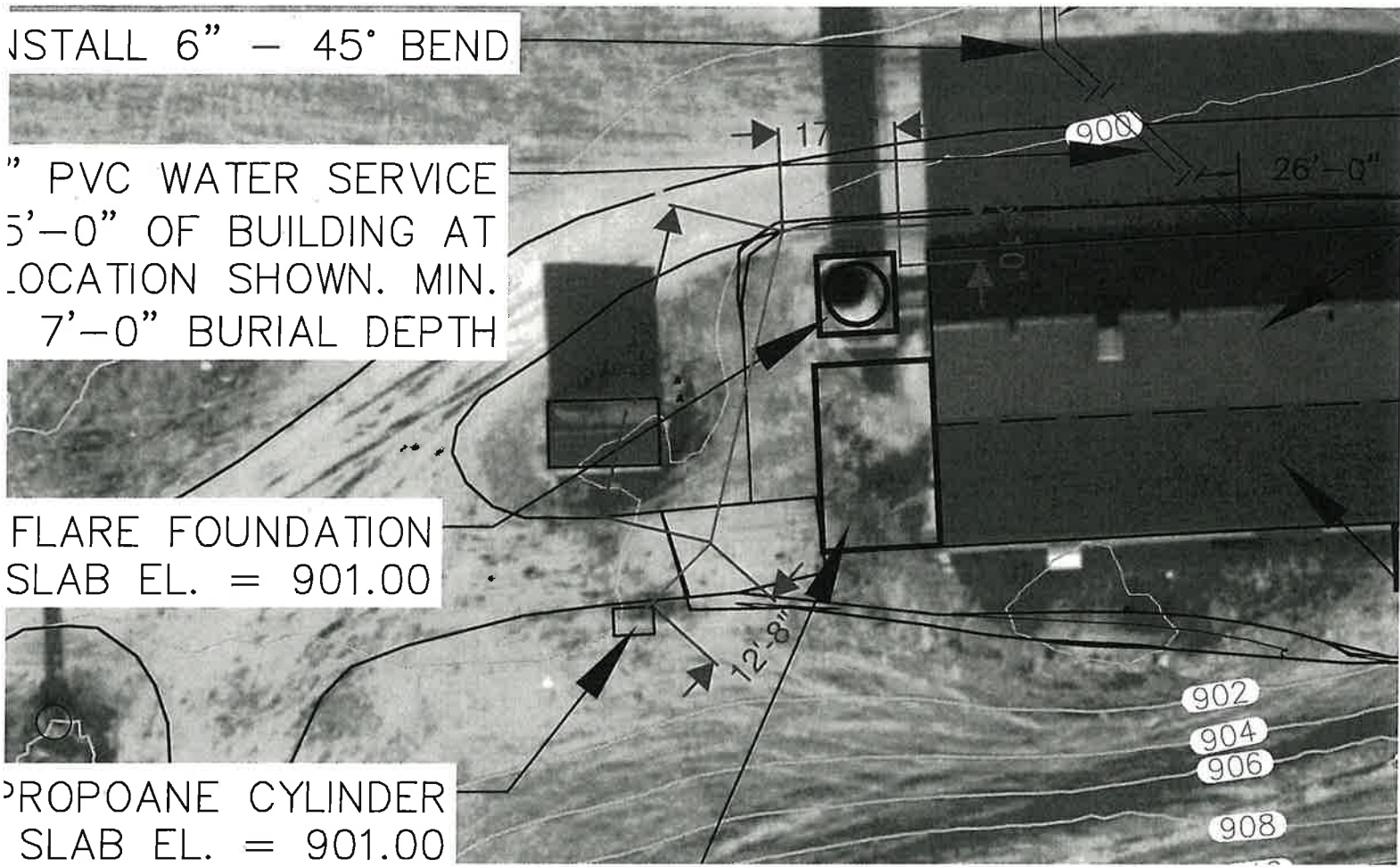

Date of Issuance: May 16, 2019

Effective Date:

May 16, 2019

Owner: City of Fargo Division of Solid Waste

Owner's Contract No.:

SW 16-03

Contractor: Rickard Electric

Contractor's Project No.:

Engineer: Wenck Associates Inc.

Engineer's Project No.: 0208-0140

Project: Landfill Gas Compression System Expansion

Contract Name:

The Contract is modified as follows upon execution of this Change Order:

Description: Electrical Work to provide 110 VAC, single phase power for lighting in the Cargill valve building located west of the Compression Building. Electrical work shall include using a spare 110 VAC circuit breaker in the low voltage panel LP-1, installing conduit from LP-1 to the south exterior of the building. Contractor shall install electrical service cable and buried conduit from the Main Building Electrical Room to the Cargill Valve building.

Contractor shall coordinate the buried conduit routing plan with the mechanical contractor, Robert Gibb & Sons.

The proposal estimate for this work provided by Rickard Electric, Inc. is attached to this change order.

CHANGE IN CONTRACT PRICE	CHANGE IN CONTRACT TIMES
Original Contract Price: \$ <u>534,830.00</u>	Original Contract Times: Substantial Completion: <u>June 30, 2019</u> Ready for Final Payment: _____ days or dates
[Increase] [Decrease] from previously approved Change Orders No. <u>0</u> to No. <u>3</u> : \$ <u>910.07</u>	[Increase] [Decrease] from previously approved Change Orders No. <u> </u> to No. <u> </u> : Substantial Completion: <u>No Change</u> Ready for Final Payment: _____ days
Contract Price prior to this Change Order: \$ <u>535,740.07</u>	Contract Times prior to this Change Order: Substantial Completion: <u>June 30, 2019</u> Ready for Final Payment: _____ days or dates
[Increase] [Decrease] of this Change Order: \$ <u>1,075.00</u>	[Increase] [Decrease] of this Change Order: Substantial Completion: <u>No Change</u> Ready for Final Payment: <u>No Change</u> days or dates
Contract Price incorporating this Change Order: \$ <u>536,815.07</u>	Contract Times with all approved Change Orders: Substantial Completion: <u>No Change</u> Ready for Final Payment: <u>No Change</u> days or dates

RECOMMENDED:		ACCEPTED:		ACCEPTED:	
By:	_____	By:	_____	By:	_____
	<i>M. D. Dandy</i>				<i>Andrew W. ...</i>
	_____		_____		_____
	Engineer (if required)		Owner (Authorized Signature)		Contractor (Authorized Signature)
Title:	Project Manager	Title	_____	Title	President
Date:	May 16, 2019	Date	_____	Date	05/17/2019

Approved by Funding Agency (if applicable)

By: _____ Date: _____
Title: _____

PROPOSAL

2968



RICKARD ELECTRIC, INC.

Electrical Contractors
1220 41st Street NW
Fargo, North Dakota 58102
(701) 281-0766 FAX (701) 282-3239

EMAIL ADDRESS: darrin@reifargo.com
WEB SITE: www.reifargo.com

TO: WENCK ASSOCIATES
3310 FIECHTNER DRIVE S
FARGO, ND 58103

PHONE:	DATE: 5/15/2019
JOB NAME/LOCATION LANDFILL CARGILL SHED CITY OF FARGO LANDFILL FARGO ND 58104	
JOB NUMBER:	JOB PHONE: (701) 297-9600

We hereby submit an estimate for:
ELECTRICAL WORK TO PROVIDE 110V POWER FOR LIGHTS IN THE CARGILL VALVE SHED

SCOPE OF WORK

- TRENCH FROM THE BUILDING TO THE ELECTRICAL ROOM ON THE SE SIDE OF THE BUILDING
- PROVIDE (1) 110V CIRCUIT FROM SPARE IN PANEL LP-1

WE PROPOSE hereby to furnish material and labor-complete in accordance with the above specifications, for the sum of:
ONE THOUSAND SEVENTY FIVE AND 00/100 dollars (\$1,075.00)

Payment to be made as follows: UPON INVOICE

All material is guaranteed to be as specified. All work to be completed in a professional manner according to standard practices. Any alteration or deviation from above specifications involving extra costs will be executed upon only upon written orders, and will become an extra charge over and above the estimate. All agreements contingent upon strikes, accidents or delays beyond our control. Owner to carry fire, tornado, and other necessary insurance. Our workers are fully covered by Worker's Compensation insurance.

Authorized
Signature

Darrin Dietrich

Note: This proposal may be withdrawn by us if not accepted within 30 days

ACCEPTANCE OF PROPOSAL

The above prices, specifications and conditions are satisfactory and are hereby accepted. You are authorized to do the work as specified. Payment to be made as outlined above.

Signature: _____

Signature: _____

Date of Acceptance: _____

Date of Issuance: May 16, 2019
 Owner: City of Fargo Division of Solid Waste
 Contractor: Rickard Electric
 Engineer: Wenck Associates Inc.
 Project: Landfill Gas Compression System Expansion

Effective Date:
 May 16, 2019
 Owner's Contract No.:
 SW 16-03
 Contractor's Project No.:
 Engineer's Project No.: 0208-0140
 Contract Name:

The Contract is modified as follows upon execution of this Change Order:

Description: Electrical Work to provide 480 VAC, 3 phase power to leachate pumps located west of the Compression Building. Electrical work shall include using a spare 30 amp circuit breaker in panel PP-1, installing conduit from PP-1 to the south exterior of the building. Contractor shall install electrical service cable and buried 1-inch diameter Schedule 80 PVC conduit from the Main Building Electrical Room to the east leachate pump and pull in one 480 VAC, 30 amp circuit. The east leachate pumping system then jumps over to feed the leachate pump located further to the west.

Contractor shall coordinate the buried conduit routing plan with the mechanical contractor, Robert Gibb & Sons.

The proposal estimate for this work provided by Rickard Electric, Inc. is attached to this change order.

CHANGE IN CONTRACT PRICE	CHANGE IN CONTRACT TIMES
Original Contract Price: \$ <u>534,830.00</u>	Original Contract Times: Substantial Completion: <u>June 30, 2019</u> Ready for Final Payment: _____ <div style="text-align: right;">days or dates</div>
[Increase] [Decrease] from previously approved Change Orders No. <u>0</u> to No. <u>4</u> : \$ <u>1,985.07</u>	[Increase] [Decrease] from previously approved Change Orders No. <u> </u> to No. <u> </u> : Substantial Completion: <u>No Change</u> Ready for Final Payment: _____ <div style="text-align: right;">days</div>
Contract Price prior to this Change Order: \$ <u>536,815.07</u>	Contract Times prior to this Change Order: Substantial Completion: <u>June 30, 2019</u> Ready for Final Payment: _____ <div style="text-align: right;">days or dates</div>
[Increase] [Decrease] of this Change Order: \$ <u>2,395.00</u>	[Increase] [Decrease] of this Change Order: Substantial Completion: <u>No Change</u> Ready for Final Payment: <u>No Change</u> <div style="text-align: right;">days or dates</div>
Contract Price incorporating this Change Order: \$ <u>539,210.07</u>	Contract Times with all approved Change Orders: Substantial Completion: <u>No Change</u> Ready for Final Payment: <u>No Change</u> <div style="text-align: right;">days or dates</div>

RECOMMENDED:		ACCEPTED:		ACCEPTED:	
By:	_____	By:	_____	By:	_____
	<i>Matt Dandy</i>				<i>Andrew White</i>
	_____		_____		_____
	Engineer (if required)		Owner (Authorized Signature)		Contractor (Authorized Signature)
Title:	Project Manager	Title	_____	Title	President
Date:	May 16, 2019	Date	_____	Date	05/17/2019

Approved by Funding Agency (if applicable)

By: _____ Date: _____
Title: _____

PROPOSAL 2967



RICKARD ELECTRIC, INC.

Electrical Contractors
1220 41st Street NW
Fargo, North Dakota 58102
(701) 281-0766 FAX (701) 282-3239

EMAIL ADDRESS: darrin@reifargo.com
WEB SITE: www.reifargo.com

TO: WENCK ASSOCIATES
3310 FIECHTNER DRIVE S
FARGO, ND 58103

PHONE:	DATE: 5/15/2019
JOB NAME/LOCATION LANDFILL LEACHATE PUMPS CITY OF FARGO LANDFILL FARGO ND 58104	
JOB NUMBER:	JOB PHONE: (701) 297-9600

We hereby submit an estimate for:
ELECTRICAL WORK TO PROVIDE 480V 3 PHASE POWER TO LEACHATE PUMPS WEST OF THE GAS COMPRESSION BUILDING

SCOPE OF WORK

- TRENCH (1) 1" SCH80 PVC UNDERGROUND TO THE EAST LEACHATE PUMP AND PULL IN (1) 3 PHASE 30 AMP CIRCUIT
- THE EAST PUMPING SYSTEM THEN JUMPS OVER TO FEED THE WEST

***WILL UTILIZE SPARE 30 AMP BREAKER IN PANEL PP-1

WE PROPOSE hereby to furnish material and labor-complete in accordance with the above specifications, for the sum of:
TWO THOUSAND THREE HUNDRED NINETY FIVE AND 00/100 dollars (\$2,395.00)

Payment to be made as follows: UPON INVOICE

All material is guaranteed to be as specified. All work to be completed in a professional manner according to standard practices. Any alteration or deviation from above specifications involving extra costs will be executed upon only upon written orders, and will become an extra charge over and above the estimate. All agreements contingent upon strikes, accidents or delays beyond our control. Owner to carry fire, tornado, and other necessary insurance. Our workers are fully covered by Worker's Compensation insurance.

Authorized
Signature

Darrin Dietrich

Note: This proposal may be withdrawn by us if not accepted within 30 days

ACCEPTANCE OF PROPOSAL

The above prices, specifications and conditions are satisfactory and are hereby accepted. You are authorized to do the work as specified. Payment to be made as outlined above.

Signature: _____

Signature: _____

Date of Acceptance: _____



PUBLIC WORKS/OPERATIONS



Fleet Management, Forestry,
Streets & Sewers, Watermeters,
Watermains & Hydrants
402 23rd STREET NORTH
FARGO, NORTH DAKOTA 58102
PHONE: (701) 241-1453
FAX: (701) 241-8100

June 11, 2019

The Honorable Board of City Commissioners
City of Fargo
225 North Fourth Street
Fargo, ND 58102

RE: RFP19086-Automated Side Load Refuse Truck

Commissioners:

On May 31st 2019, proposals were received and read for one (1) Automated Side-Load Refuse Truck (RFP19086). Seven proposals were submitted by four vendors.

The results are as follows:

<u>Firm</u>	<u>Price w/Trade</u>	<u>Conventional chassis</u>
Northern Truck (Heil)	\$231,001.00	\$205,855.00
Sanitation Products (Bridgeport)	\$225,111.00	\$206,742.00
Northern Truck (Curbtender)	\$232,591.00	\$207,453.00
Sanitation Products (Loadmaster)	\$228,869.00	\$210,500.00
Sanitation Products (Labrie)	\$236,159.00	\$217,790.00
Olympic Sales (New Way)	\$235,980.00	\$223,487.00
Bruckner Truck (G&H MFG)	\$273,613.00	N/A

The review committee consisting of Terry Ludlum, Dave Rheault, and Tanner Smedshammer determined that a Conventional Chassis option for the Automatic Side Loader would be best suited for the Solid Waste Department's needs. Six vendors met the required specifications and the prices were within expected parameters. Our recommendation is to award Northern Truck Equipment with the Heil Automatic Side Loader. Funding for this project has been included in the 2019 Solid Waste budget.

SUGGESTED MOTION:

Approve the recommendation to purchase one (1) Automatic Side Loader Refuse Truck to Northern Truck Equipment for the purchase price of \$205,855.00

Respectfully Submitted,

Tanner Smedshammer
Fleet Management Specialist



**Request for Proposals (RFP)
Auto side load**

5/31/19

Solid Waste Dept

Proposal Evaluation Summary

	Northern Truck	Northern Truck	Olympic Sales	Sanitation Products	Sanitation Products	Sanitation Products	Bruckner Truck
Body Manf.	Heil	Curbtender	Neway	Labrie	Bridgeport	Loadmaster	G&H MFG
Body Model	Rapid Rail	27 YD ASL	Sidewinder29	Automizer	Ranger	Eclipse	Scorpion
	Pete	Pete	Pete	Pete	Pete	Pete	Mack
Trade In (Unit 150)	\$5,000.00	\$5,000.00	\$0.00	\$2,500.00	\$2,500.00	\$2,500.00	\$0.00
Bid Price w/Trade	\$231,001.00	\$232,591.00	\$235,980.00	\$236,159.00	\$225,111.00	\$228,869.00	\$273,613.00
Conventional chassis option -w/Trade	\$205,855.00	\$207,453.00	\$223,487.00	\$217,790.00	\$206,742.00	\$210,500.00	N/A
Delivery(days)	250-280	250-280	240-270	270	270	270	240
Warranty	1	1	1	1	1	1	1
General	96"	>144"	144"	144"	144"	144"	96"
Arm Reach							

20

REPORT OF ACTION

PUBLIC WORKS PROJECTS EVALUATION COMMITTEE

Improvement District No. BN-19-A3 Type: Contract Amendment #2
 Location: 52nd Ave S, 45th St – 63rd St Date of Hearing: 6/10/2019

<u>Routing</u>	<u>Date</u>
City Commission	6/17/2019
PWPEC File	X
Project File	Kevin Gorder

The Committee reviewed the attached communication from Division Engineer, Kevin Gorder, regarding Contract Amendment #2 submitted by Houston Engineering in the amount of \$33,042.00, bringing the total contract amount to \$259,461.00. This Amendment is for the use of two additional Inspectors to assist with storm sewer and water main installation.

Staff is recommending approval of Contract Amendment #2 in the amount of \$33,042.00, bringing the total contract amount to \$259,461.00.

On a motion by Bruce Grubb, seconded by Kent Costin, the Committee voted to recommend approval of Contract Amendment #2 to Houston Engineering.

RECOMMENDED MOTION

Concur with the recommendations of PWPEC and approve Amendment #2 in the amount of \$33,042.00 to Houston Engineering.

PROJECT FINANCING INFORMATION:

Recommended source of funding for project: Sales Tax

Developer meets City policy for payment of delinquent specials
 Agreement for payment of specials required of developer
 Letter of Credit required (per policy approved 5-28-13)

Yes	No
<u>N/A</u>	<u>N/A</u>
<u>N/A</u>	<u>N/A</u>
<u>N/A</u>	<u>N/A</u>

COMMITTEE

Tim Mahoney, Mayor
 Nicole Crutchfield, Director of Planning
 Steve Dirksen, Fire Chief
 Bruce Grubb, City Administrator
 Ben Dow, Director of Operations
 Steve Sprague, City Auditor
 Brenda Derrig, City Engineer
 Kent Costin, Finance Director

Present	Yes	No	Unanimous
<u>Γ</u>	<u>Γ</u>	<u>Γ</u>	<u>Γ</u>
<u>✓</u>	<u>✓</u>	<u>Γ</u>	
<u>✓</u>	<u>✓</u>	<u>Γ</u>	
<u>✓</u>	<u>✓</u>	<u>Γ</u>	
<u>Γ</u>	<u>Γ</u>	<u>Γ</u>	
<u>Γ</u>	<u>Γ</u>	<u>Γ</u>	
<u>✓</u>	<u>✓</u>	<u>Γ</u>	
<u>✓</u>	<u>✓</u>	<u>Γ</u>	

ATTEST:

 Brenda E. Derrig, P.E.
 City Engineer

C: Kristi Olson

Memorandum

To: Members of PWPEC
From: Kevin Gorder, Division Engineer
Date: June 6, 2019
Re: Additional Inspection Staff on 52nd Avenue South Roadway – BN-19-A3
Amendment No. 2

Background

52nd Avenue is one of the largest projects under construction in the City of Fargo this summer. The project includes storm sewer, water mains, grading, base, concrete pavement, and two bridges over Drain 27. Current staffing on the project is two Fargo Engineering Staff, part-time Fargo Engineering survey crew, and Houston Engineering staff on the bridges. Current operations include grading, base, and concrete pavement between 45th Street and Drain 27. Scheduled work in about a week include continuing the work near 45th Street and adding two pipe crews to complete storm sewer and water main, west of Veterans Boulevard and a grading crew in this area as well. Current project staff is not sufficient to meet the demands of all this work and ensure the best possible product for the City of Fargo.

Engineering asked Houston Engineering for a quote to provide two inspectors to assist with storm sewer and water main installation. We estimate the need for one inspector for three weeks and another inspector for two weeks. Houston's estimate to provide this service is \$33,042. Their quote is attached.

Recommended Motion

Approve Amendment No. 2 to use Houston Engineering staff to assist in the contract administration on 52nd Avenue South as quoted.

KOG\jmg
Attachment

Fargo Corporate Office 701.237.5065 701.237.5101

1401 21st Avenue North Fargo ND 58102



PROFESSIONAL SERVICES

AMENDMENT No. 2 - FOR ADDITIONAL ENGINEERING SERVICES

Project: City of Fargo Project BN-19-A3 – 52nd Ave South form 45th Street to West of 63rd Street South
Amendment No. 2 – Underground Utility Inspection
HE Project No. 6059-0160

Client: City of Fargo
225 4th Street N.
Fargo, ND 58102
Phone (701) 241-1545
Attn: Kevin Gorder, Division Engineer

Location of Project: City of Fargo, Cass County, North Dakota

Description of Work: This contract amendment is for additional Professional Engineering services to assist the City of Fargo personnel inspect underground utilities along 52nd Ave S.

Basis of Proposal: This amendment covers the additional services as described above.

Fee: The total fee for the above described tasks is \$33,042. Additional work required beyond the scope listed above will be billed at our current hourly rates. Houston Engineering, Inc. will perform the services as outlined above. Tasks will be performed in accordance with our current hourly rates (Attachment 2).

Conditions: Services will be invoiced monthly and are due and payable upon receipt.

Limitation of Liability: Houston Engineering, Inc. agrees to indemnify and save the client harmless from any loss, cost, or expense including attorney fees, claimed by third parties for property damage or bodily injury, including death, caused by the negligence of Houston Engineering, Inc. or its employees in connection with Houston Engineering, Inc.'s services. The client agrees to indemnify and save Houston Engineering, Inc. harmless from any loss, cost, or expense, including attorney fees, claimed by third parties for property damage or bodily injury including death, caused by the negligence of the client or its employees in connection with the operations of the client. If the



Page 2

negligence of both Houston Engineering, Inc. and the client (or a person identified above for whom each is liable) is the cause of such damage or injury, the loss, cost, or expense shall be shared between Houston Engineering, Inc. and the client in proportion to their relative degrees of negligence and the right of indemnity shall apply for such proportion. Neither party hereto shall be liable to the other for incidental, special or indirect damages nor shall Houston Engineering, Inc. be liable for any cost or expense that provides betterment, upgrade or enhancement of the project.

Houston Engineering, Inc. hereby proposes, and the client hereby authorizes, the above described services to be performed by Houston Engineering, Inc. under the terms and conditions set forth.

Authorization:

Proposal: Houston Engineering, Inc.

Client: City of Fargo

Signature: _____

Signature: Rick R. St Germain

Title: _____

Title: Vice President

Date: _____

Date: 5/31/19

Quick Budget 2019 standard Rates
 Fargo 52nd Ave Underground Inspection

Name	Category	Rate	Hours	Cost	Notes
Adam W	Project Engineer	\$ 168.00	3	\$504	
Zach H	Engineer I	\$ 121.00	150	\$18,150	3 wks @ 50 hrs
John F	Const. Engineer	\$ 139.00	100	\$13,900	2 wks @ 50 hrs
			0	\$0	
Miles		\$ 0.78	625	\$488	25 miles per trip

	Total	\$33,042
--	-------	----------



2019 FEE SCHEDULE

The following is a schedule of hourly rates and charges for engineering and surveying services offered by Houston Engineering, Inc. These rates are subject to a modest increase on January 1st of each year (typically no more than 5%).

Category	2019 Rates
Engineer I	\$121
Engineer II	134
Engineer III	151
Project Engineer	168
Project Manager	184
Sr Project Manager	202
Scientist I	\$121
Scientist II	134
Scientist III	152
Project Mgr – Environmental	178
Sr Project Mgr – Environmental	202
Hydrogeologist I	\$121
Hydrogeologist II	134
Hydrogeologist III	152
Sr Hydrogeologist	190
Construction Engineer	\$139
Sr Construction Engineer	165
Land Surveyor I	\$121
Land Surveyor II	139
Land Surveyor III	153
Project Mgr – Land Surveying	165
Sr Project Manager – Land Surveying	184
Survey Crews:	
1-Person Crew (+ equipment)	\$147
2-Person Crew (+ equipment)	178
3-Person Crew (+ equipment)	222
4-Person Crew (+ equipment)	248
Landscape Architect	\$129
CAD Technician I	\$82
CAD Technician II	95
CAD Supervisor	108
Designer I	\$127
Designer II	136
Sr Designer	146
Engineering Specialist	155
Technician Intern (all areas)	\$82
Technician I	\$95
Technician II	108
Sr Technician	121

Category	2019 Rates
Right-of-Way Technician	\$110
Right-of-Way Specialist	184
GIS Analyst I	\$90
GIS Analyst II	105
GIS Analyst III	121
Sr GIS Analyst	139
Project Manager – GIS	152
Sr Project Manager – GIS	178
Software Engineer I	\$105
Software Engineer II	121
Software Engineer III	139
Sr Software Engineer	152
Computer Technician	\$146
Communications Specialist	\$82
Sr Communications Specialist	90
Administrative Assistant	\$77
Sr Administrative Assistant	82
Planner	\$133
Senior Planner	184
Legislative/Grant Specialist	\$171
Expert Witness	222
Drone Pilot	\$129
Drone Visual Observer	49

Chargeable Expenses	Rate
Subsistence	Actual Cost
Mileage-Vehicles:	
2-Wheel Drive	IRS Standard Rate
4-Wheel Drive	IRS Standard Rate + \$0.20/Mile
GPS Equipment	\$25/hour/unit
Robotic Total Station	\$40/hour
ATV/Snowmobile/Boat	\$15/hour
ATV with Tracks	\$30/hour
Hydrone RCV	\$50/hour
Small UAS	\$25/hour
Delivery, Postage, Printing	Actual Cost
Surveying Materials, Special Equipment, and other Materials required	Actual Cost
Subconsultants	Actual Cost + 10%

PUBLIC WORKS PROJECTS EVALUATION COMMITTEE

Improvement District No. BN-19-A2

Type: Change Orders #1 - 7

Location: 52nd Ave S, 45th St – 63rd St

Date of Hearing: 6/10/2019

Routing	Date
City Commission	6/17/2019
PWPEC File	X
Project File	Kevin Gorder

The Committee reviewed the accompanying correspondence from Division Engineer, Kevin Gorder, related to Change Orders #1 - 7 submitted by the NDDOT in the amount of \$35,323.89, bringing the total contract amount to \$12,395,666.89. The requested Change Orders can be summarized as follows:

1. No cost Change Order – change removals from tons to SY
2. No cost Change Order – change common excavation from a measured quantity to pay plan
3. Assist with snow removal on collector streets for better sight angles at intersections - \$5,255.00
4. Change in erosion control items to fit project better - \$1,320.00
5. Additional decorative form liners on bridge - \$15,101.89
6. Drainage improvements near U-Haul - \$13,647.00
7. No cost Change Order – String less paving

Staff is recommending approval of Change Orders #1 - 7 in the amount of \$35,323.89, bringing the total contract amount to \$12,395,666.89.

On a motion by Bruce Grubb, seconded by Kent Costin, the Committee voted to recommend approval of Change Orders #1 - 7.

RECOMMENDED MOTION

Concur with recommendations of PWPEC and approve Change Orders #1 - 7 in the amount of \$35,323.89 to NDDOT.

PROJECT FINANCING INFORMATION:

Recommended source of funding for project: Fed, SE Cass, Cass Cty Hwy, COF Sales Tax & Special Assessments

	Yes	No
Developer meets City policy for payment of delinquent specials	N/A	
Agreement for payment of specials required of developer	N/A	
Letter of Credit required (per policy approved 5-28-13)	N/A	

COMMITTEE

	Present	Yes	No	Unanimous
Tim Mahoney, Mayor	<input type="checkbox"/>	<input type="checkbox"/>	<input type="checkbox"/>	<input checked="" type="checkbox"/>
Nicole Crutchfield, Director of Planning	<input checked="" type="checkbox"/>	<input checked="" type="checkbox"/>	<input type="checkbox"/>	
Steve Dirksen, Fire Chief	<input checked="" type="checkbox"/>	<input checked="" type="checkbox"/>	<input type="checkbox"/>	
Bruce Grubb, City Administrator	<input checked="" type="checkbox"/>	<input checked="" type="checkbox"/>	<input type="checkbox"/>	
Ben Dow, Director of Operations	<input type="checkbox"/>	<input type="checkbox"/>	<input type="checkbox"/>	
Steve Sprague, City Auditor	<input type="checkbox"/>	<input type="checkbox"/>	<input type="checkbox"/>	
Brenda Derrig, City Engineer	<input checked="" type="checkbox"/>	<input checked="" type="checkbox"/>	<input type="checkbox"/>	
Kent Costin, Finance Director	<input checked="" type="checkbox"/>	<input checked="" type="checkbox"/>	<input type="checkbox"/>	

ATTEST:

C: Kristi Olson

 Brenda E. Derrig, P.E.
 City Engineer

Memorandum

To: Members of PWPEC
From: Kevin Gorder, Division Engineer
Date: June 6, 2019
Re: BN-19-A2 - 52nd Ave Project Change Orders #1-7

To date, seven change orders have been issued for Improvement District BN-19-A2 on 52nd Ave S. Many of them are specification changes at no cost to the project. The change orders are summarized below with copies attached.

1. No cost change order – change removals from tons to SY
2. No cost change order – change common excavation from a measured quantity to pay plan
3. Assist with snow removal on collector streets for better sight angles at intersections - \$5,255
4. Change in erosion control items to fit project better - \$1,320
5. Additional decorative form liners on bridge - \$15,101.89
6. Drainage improvements near U-Haul - \$13,647
7. No cost change order – String less paving

Recommended Motion

Approve Change Orders 1-7 for a total of \$35,323.89 for Improvement District BN-19-A2.

**North Dakota Department of Transportation
Change Order**

Change Order No: 1

Project: SU-8-984(164)

PCN: 22007

SubProject: 1 GRADING, SALVAGED BASE, PCC PAVEMENT, HMA, County: Cass

For: GRADING, SALVAGED BASE, PCC PAVEMENT, HMA, STORM DRAIN

Contractor: KPH INC
9530 39TH ST S
FARGO, ND 58104

Original Contract Amount:
\$19,197,385.45

Date Created: 03/07/2019

Date Approved: 04/23/2019

Spec No	Code No	Item of Work	Unit	Original Quantity	+ or - Quantity	Unit Price	Increase Amount	Decrease Amount
ADDED CONTRACT ITEM								
NON-PARTICIPATING (FEDERAL FUNDS)								
202	132	REMOVAL OF BITUMINOUS SURFACING	SY	0.00	52,021.00	5.216	271,341.54	
DECREASE TO BID ITEM								
PARTICIPATING (FEDERAL FUNDS)								
202	136	REMOVAL OF PAVEMENT	TON	38,763.00	-38,763.00	7.000		-271,341.00
Net Increase or Decrease to Date				-271,341.00	Part	271,341.54	Non-Part	TOTALS
							271,341.54	-271,341.00
							271,341.54	
								-271,341.00

Due to This Change, the Contract Time:
NO CHANGE.

Classification

Administrative Change

EXPLANATION OF CHANGE IN PLAN RECOMMENDED

If the federal funds authorized in the cost participation agreement with the local agency is exceeded and federal funds are not available for this change, the local agency will assume the total cost of this change order.

The contractor has requested a couple pay items changes. The first is to change the method of measurement of the removal of pavement from tons to SY. The contractor bid the project to haul in virgin aggregate and blend that with the asphalt paving removal to create an asphalt blended base. NDDOT specifications allow 100% millings under concrete, the city specifications require a 50/50 blend so that is preferred by the city. This change will use the basis of estimate in the contract documents for conversion. The contractor has accepted the possible risk of the current roadway being thicker than shown in the plans and waives any request for additional payment for thicker pavement. The City of Fargo reserves their right to ask for a price adjustment if the existing pavement is not as thick as the contract documents show.

KPH INC
Prime Contractor

04/16/2019
DATE

Kevin Gorder
Project Engineer

04/23/2019
DATE

**North Dakota Department of Transportation
Change Order**

Change Order No: 2

Project: SU-8-984(164)

PCN: 22007

SubProject: 1 GRADING, SALVAGED BASE, PCC PAVEMENT, HMA, County: Cass

For: GRADING, SALVAGED BASE, PCC PAVEMENT, HMA, STORM DRAIN

Contractor: KPH INC
9530 39TH ST S
FARGO, ND 58104

Original Contract Amount:
\$19,197,385.45

Date Created: 03/11/2019

Date Approved: 04/23/2019

Spec No	Code No	Item of Work	Unit	Original Quantity	+ or - Quantity	Unit Price	Increase Amount	Decrease Amount
DECREASE TO BID ITEM								
PARTICIPATING (FEDERAL FUNDS)								
203	101	COMMON EXCAVATION-TYPE A	CY	11,169.00	-11,169.00	6.750		-75,390.75
INCREASE TO BID ITEM								
NON-PARTICIPATING (FEDERAL FUNDS)								
203	101	COMMON EXCAVATION-TYPE A	CY	11,169.00	11,169.00	6.750	75,390.75	
Net Increase or Decrease to Date				-346,731.75	Part	346,732.29	Non-Part	TOTALS
							75,390.75	-75,390.75
							75,390.75	
							NON-PARTICIPATING	
							PARTICIPATING	-75,390.75

Due to This Change, the Contract Time:
NO CHANGE.

Classification

Administrative Change

EXPLANATION OF CHANGE IN PLAN RECOMMENDED

If the federal funds authorized in the cost participation agreement with the local agency is exceeded and federal funds are not available for this change, the local agency will assume the total cost of this change order.

The contractor has also requested common excavation be paid as lump sum. NDDOT specifications allow this bid item to be bid as lump sum so this change is part of the NDDOT specifications. The specifications require deducting pipe cuts, water main cuts, etc be deducted from the common excavation quantity. By changing to lump sum, this allows the contractor to build the project without having to keep this separate. If any changes are made to areas changing plan quantity, the quantity will change accordingly. This change benefits the City of Fargo by not having to provide a survey crew to measure the entire project before and after the common excavation.

NDDOT specifications allow topsoil be paid as plan quantity if the contractor and engineer agree. The contractor has asked for this option and the city of Fargo agrees with this change.

KPH INC
Prime Contractor

04/16/2019
DATE

Kevin Gorder
Project Engineer

04/23/2019
DATE

**North Dakota Department of Transportation
Change Order**

Change Order No: 3

Project: SU-8-984(164)

PCN: 22007

SubProject: 1 GRADING, SALVAGED BASE, PCC PAVEMENT, HMA, County: Cass

For: GRADING, SALVAGED BASE, PCC PAVEMENT, HMA, STORM DRAIN

Contractor: KPH INC
9530 39TH ST S
FARGO, ND 58104

Original Contract Amount:
\$19,197,385.45

Date Created: 04/23/2019

Date Approved: 05/03/2019

Spec No	Code No	Item of Work	Unit	Original Quantity	+ or - Quantity	Unit Price	Increase Amount	Decrease Amount
ADDED CONTRACT ITEM								
NON-PARTICIPATING (FEDERAL FUNDS)								
930	9699	CLEANING	L SUM	0.00	1.00	5,255.000	5,255.00	
Net Increase or Decrease to Date				-346,731.75	Part	351,987.29	Non-Part	TOTALS
							5,255.00	
							NON-PARTICIPATING	5,255.00
							PARTICIPATING	

Due to This Change, the Contract Time:
NO CHANGE.

Classification

Change Approved In Field by P.E.

EXPLANATION OF CHANGE IN PLAN RECOMMENDED

If the federal funds authorized in the cost participation agreement with the local agency is exceeded and federal funds are not available for this change, the local agency will assume the total cost of this change order.

The project started March 1 with the closure of the bridge between 45th St and Veterans. The detour was posted as per plan and all requirements in the contract were met. Traffic patterns changed and caused some safety concerns on the collectors in the area of the detour and how it impacted traffic volumes and dropoff at the neighborhood school. Due to the amount of snow this winter, the City of Fargo asked the contractor to haul snow away from the collector streets in an effort to improve sight distance. City crews were overloaded removing snow from the arterials so this work was added to the contract. Force account methods were used to keep track of this cost.

NA

KPH INC 04/23/2019

Prime Contractor

DATE

Kevin Gorder 05/03/2019

Project Engineer

DATE

**North Dakota Department of Transportation
Change Order**

Change Order No: 4

Project: SU-8-984(164)

PCN: 22007

SubProject: 1 GRADING, SALVAGED BASE, PCC PAVEMENT, HMA, County: Cass

For: GRADING, SALVAGED BASE, PCC PAVEMENT, HMA, STORM DRAIN

Contractor: KPH INC
9530 39TH ST S
FARGO, ND 58104

Original Contract Amount:
\$19,197,385.45

Date Created: 05/02/2019

Date Approved:

Spec No	Code No	Item of Work	Unit	Original Quantity	+ or - Quantity	Unit Price	Increase Amount	Decrease Amount
ADDED CONTRACT ITEM								
PARTICIPATING (FEDERAL FUNDS)								
261	106	FIBER ROLLS 9IN	LF	0.00	600.00	2.200	1,320.00	
Net Increase or Decrease to Date				-345,411.75	Part	351,987.29	Non-Part	TOTALS
							1,320.00	
								NON-PARTICIPATING
								PARTICIPATING
							1,320.00	

Due to This Change, the Contract Time:
NO CHANGE.

Classification

Change Approved In Field by P.E.

EXPLANATION OF CHANGE IN PLAN RECOMMENDED

If the federal funds authorized in the cost participation agreement with the local agency is exceeded and federal funds are not available for this change, the local agency will assume the total cost of this change order.

The plans call for silt fence for erosion control but in some areas, fiber rolls would be a better option. 9" Fiber rolls will be added to the contract but we will use 6" spec and code. The price quoted for 9" Fiber rolls is very similar to the 2018 average bid price for 6" Fiber rolls.

 5-8-19

CONTRACTOR DATE

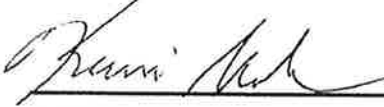

 Approval Recommended Approved
PROJECT ENGINEER DATE

CITY/COUNTY/OTHER OFFICIAL DATE

 Approval Recommended Approved
DISTRICT ENGINEER DATE

REPRESENTING DATE

 Approval Recommended Approved
OFFICE OF OPERATIONS DATE

North Dakota Department of Transportation
Change Order

Change Order No: 5
SubProject: 3 STRUCTURE REPLACEMENT- RIGHT

Project: SU-8-984(164)
County: Cass

PCN: 22007

For: GRADING, SALVAGED BASE, PCC PAVEMENT, HMA, STORM DRAIN

Contractor: KPH INC
9530 39TH ST S
FARGO, ND 58104

Original Contract Amount:
\$19,197,385.45

Date Created: 06/03/2019

Date Approved:

Spec No	Code No	Item of Work	Unit	Original Quantity	+ or - Quantity	Unit Price	Increase Amount	Decrease Amount
ADDED CONTRACT ITEM								
PARTICIPATING (FEDERAL FUNDS)								
602	9998	Additional Form Liner	L SUM	0.00	1.00	10,816.890	10,816.89	
INCREASE TO BID ITEM								
PARTICIPATING (FEDERAL FUNDS)								
602	1130	CLASS AE-3 CONCRETE	CY	194.80	2.80	1,450.000	4,060.00	
612	116	REINFORCING STEEL-GRADE 60-EPOXY COATED	LBS	46,583.00	250.00	1.700	425.00	
Net Increase or Decrease to Date			-330,309.86	Part	351,987.29	Non-Part	TOTALS	15,101.89
							NON-PARTICIPATING	
							PARTICIPATING	15,101.89

Due to This Change, the Contract Time:
NO CHANGE.

Classification

Change Approved In Field by P.E.

EXPLANATION OF CHANGE IN PLAN RECOMMENDED

If the federal funds authorized in the cost participation agreement with the local agency is exceeded and federal funds are not available for this change, the local agency will assume the total cost of this change order.

The plans were not clear on the areas that would receive form liner impressions. The City would like to include the barriers on both sides of both bridges and to add detail on additional areas of the posts for the railing connections.

 6-3-19

CONTRACTOR DATE



 Approval Recommended () Approved
PROJECT ENGINEER DATE

CITY/COUNTY/OTHER OFFICIAL DATE

 Approval Recommended () Approved
DISTRICT ENGINEER DATE

REPRESENTING DATE

 Approval Recommended () Approved
OFFICE OF OPERATIONS DATE

**North Dakota Department of Transportation
Change Order**

Change Order No: 6

Project: SU-8-984(164)

PCN: 22007

SubProject: 1 GRADING, SALVAGED BASE, PCC PAVEMENT, HMA, County: Cass

For: GRADING, SALVAGED BASE, PCC PAVEMENT, HMA, STORM DRAIN

Contractor: KPH INC
9530 39TH ST S
FARGO, ND 58104

Original Contract Amount:
\$19,197,385.45

Date Created: 06/03/2019

Date Approved:

Spec No	Code No	Item of Work	Unit	Original Quantity	+ or - Quantity	Unit Price	Increase Amount	Decrease Amount
ADDED CONTRACT ITEM								
PARTICIPATING (FEDERAL FUNDS)								
714	7030	PIPE PVC 12IN	LF	0.00	171.00	57.000	9,747.00	
INCREASE TO BID ITEM								
PARTICIPATING (FEDERAL FUNDS)								
722	3510	INLET-TYPE 2	EA	19.00	1.00	2,400.000	2,400.00	
722	2490	MANHOLE STORM CONNECTION	EA	3.00	1.00	1,500.000	1,500.00	
Net Increase or Decrease to Date			-316,662.86	Part	351,987.29	Non-Part	TOTALS	13,647.00
							NON-PARTICIPATING	
							PARTICIPATING	13,647.00

Due to This Change, the Contract Time:
NO CHANGE.

Classification

Change Approved In Field by P.E.

EXPLANATION OF CHANGE IN PLAN RECOMMENDED

If the federal funds authorized in the cost participation agreement with the local agency is exceeded and federal funds are not available for this change, the local agency will assume the total cost of this change order.

During construction, two underground pipes were found near the U Haul property on the south side of 52nd, east of Veterans. Various options were considered and it was determined the best option was to connect these pipes into the storm sewer system. This would eliminate water discharging from the pipes onto the sidewalk and freezing on a pedestrian path.

City bids for 12" SDR pipe range from \$48/LF to \$60/LF in bids taken on City projects.

North Dakota Department of Transportation
Change Order

Change Order No: 6

Project: SU-8-984(164)

PCN: 22007

SubProject: 1 GRADING, SALVAGED BASE, PCC PAVEMENT, HMA, County: Cass

For: GRADING, SALVAGED BASE, PCC PAVEMENT, HMA, STORM DRAIN

Contractor: KPH INC
9530 39TH ST S
FARGO, ND 58104

Original Contract Amount:
\$19,197,385.45

Date Created: 06/03/2019

Date Approved:

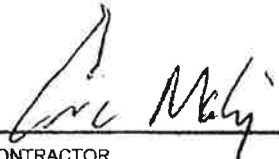

CONTRACTOR

0-3-19

DATE

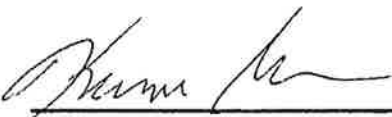

 Approval Recommended
PROJECT ENGINEER

Approved

DATE

CITY/COUNTY/OTHER OFFICIAL

DATE

 Approval Recommended
DISTRICT ENGINEER

Approved

DATE

REPRESENTING

DATE

 Approval Recommended
OFFICE OF OPERATIONS

Approved

DATE

**North Dakota Department of Transportation
Change Order**

Change Order No: 7

Project: SU-8-984(164)

PCN: 22007

SubProject: 1 GRADING, SALVAGED BASE, PCC PAVEMENT, HMA, County: Cass

For: GRADING, SALVAGED BASE, PCC PAVEMENT, HMA, STORM DRAIN

Contractor: KPH INC
9530 39TH ST S
FARGO, ND 58104

Original Contract Amount:
\$19,197,385.45

Date Created: 06/03/2019

Date Approved:

Spec No	Code No	Item of Work	Unit	Original Quantity	+ or - Quantity	Unit Price	Increase Amount	Decrease Amount
------------	------------	--------------	------	----------------------	--------------------	---------------	--------------------	--------------------

Net Increase or Decrease to Date	-316,662.86	Part	351,987.29	Non-Part	TOTALS
					NON-PARTICIPATING
					PARTICIPATING

Due to This Change, the Contract Time:
NO CHANGE.

Classification

Administrative Change

EXPLANATION OF CHANGE IN PLAN RECOMMENDED

If the federal funds authorized in the cost participation agreement with the local agency is exceeded and federal funds are not available for this change, the local agency will assume the total cost of this change order.

This change order will remove the requirement of using a string line to pave. See attached explanation.

<u>KPH INC</u>	<u>06/03/2019</u>
Prime Contractor	DATE
<u>Joe Peyerl</u>	<u>06/04/2019</u>
District 8	DATE

<u>Kevin Gorder</u>	<u>06/03/2019</u>
Project Engineer	DATE
<u>Wayde Swenson</u>	<u>06/04/2019</u>
Office of Operations	DATE

REPORT OF ACTION

PUBLIC WORKS PROJECTS EVALUATION COMMITTEE

22

Improvement District No. BN-18-K1

Type: Change Order #4

Location: Sheyenne Loop

Date of Hearing: 6/10/2019

<u>Routing</u>	<u>Date</u>
City Commission	<u>6/17/2019</u>
PWPEC File	<u>X</u>
Project File	<u>Jason Leonard</u>

The Committee reviewed the accompanying correspondence from Project Manager, Jason Leonard, regarding Change Order #4 in the amount of \$4,905.00 for an additional 900 cubic yards of fill required to meet boulevard plan grades.

Staff is recommending approval of Change Order #4 in the amount of \$4,905.00, bringing the total contract amount to \$345,141.31.

On a motion by Bruce Grubb, seconded by Kent Costin, the Committee voted to recommend approval of Change Order #4 to Fox Underground, Inc.

RECOMMENDED MOTION

Approve Change Order #4 in the amount of \$4,905.00 to Fox Underground, Inc.

PROJECT FINANCING INFORMATION:

Recommended source of funding for project: Special Assessments

Developer meets City policy for payment of delinquent specials
 Agreement for payment of specials required of developer
 Letter of Credit required (per policy approved 5-28-13)

<u>Yes</u>	<u>No</u>
<u>N/A</u>	<u>N/A</u>
<u>N/A</u>	<u>N/A</u>
<u>N/A</u>	<u>N/A</u>

COMMITTEE

- Tim Mahoney, Mayor
- Nicole Crutchfield, Director of Planning
- Steve Dirksen, Fire Chief
- Bruce Grubb, City Administrator
- Ben Dow, Director of Operations
- Steve Sprague, City Auditor
- Brenda Derrig, City Engineer
- Kent Costin, Finance Director

<u>Present</u>	<u>Yes</u>	<u>No</u>	<u>Unanimous</u>
<input type="checkbox"/>	<input type="checkbox"/>	<input type="checkbox"/>	<input checked="" type="checkbox"/>
<input checked="" type="checkbox"/>	<input checked="" type="checkbox"/>	<input type="checkbox"/>	
<input checked="" type="checkbox"/>	<input checked="" type="checkbox"/>	<input type="checkbox"/>	
<input checked="" type="checkbox"/>	<input checked="" type="checkbox"/>	<input type="checkbox"/>	
<input type="checkbox"/>	<input type="checkbox"/>	<input type="checkbox"/>	
<input type="checkbox"/>	<input type="checkbox"/>	<input type="checkbox"/>	
<input checked="" type="checkbox"/>	<input checked="" type="checkbox"/>	<input type="checkbox"/>	
<input checked="" type="checkbox"/>	<input checked="" type="checkbox"/>	<input type="checkbox"/>	

ATTEST:

C: Kristi Olson

 Brenda E. Derrig, P.E.
 Division Engineer

Memorandum

To: Members of PWPEC
From: Jason Leonard, Project Engineer
Date: May 31, 2019
Re: Improvement District No. BN-18-K1 – Change Order #4

Background:

Improvement District No. BN-18-K1 is for the new construction of underground utilities, concrete pavement, street lights and incidentals on Sheyenne Loop North.

Fox Underground Inc. is the Contractor for this project and they are requesting a Change Order for 900 cubic yards of fill that was required to meet boulevard plan grades. Engineering staff feels the Change Order price was comparable to this year's average bid prices and supports approval of Change Order #4.

Recommended Motion:

Approve Change Order #4 in the amount of \$4,905.00 to Fox Underground Inc.

JTL\klb
Attachments



PO Box 739 - West Fargo, ND 58078 - 701.361.1919

Extra Work 1

900 CY Embankment

PROJECT: City of Fargo BN-18-K1

LOCATION: Sheyenne Loop N.

Date 1/2/2019

No.	Price Breakdown	QUAN	UNIT	PRICE	EXTENSION
Equipment					
					-
					-
					-
					-
				Equipment Total	-
Labor					
					-
					-
					-
				Sub-Total	-
				Payroll Taxes at 20%	-
				Sub-Total	-
				25% Overhead and Profit	-
				Labor Total	-
Material					
	Clay Material	900.00	CY	1.50	1,350.00
				Sub-Total	1,350.00
				25% Overhead and Profit	337.50
				Material Total	1,687.50
Subcontractor					
	Valley Grading - Embankment	900.00	CY	3.25	2,925.00
				Sub-Total	2,925.00
				10% Subcontractor Allowance	292.50
				Subcontractor Total	3,217.50
				Equip Total	-
				Labor Total	-
				Material Total	1,687.50
				Subcontractor Total	3,217.50
				Extra Work Total	4,905.00



CITY OF FARGO
ENGINEERING DEPARTMENT
CHANGE ORDER REPORT

Improvement District No BN-18-K1 Change Order No 4
 Project Name Storm Sewer, PC Concrete Paving, Street Lights & Incidentals
 Date Entered 5/31/2019 For Fox Underground

This change is made under the terms of or is supplemental to your present contract, if and when approved, you are ordered to perform the work in accordance with the additions, changes, or alterations hereinafter described.

EXPLANATION OF CHANGE: Change Order # 4 - Fill -Haul

During the grading of the boulevard 900 cubic yards of fill was required to meet plan grades.

Section	Line No	Item Description	Unit	Orig Cont Qty	Prev C/O Qty	Prev Cont Qty	Curr C/O Qty	Tot Cont Qty	Unit Price (\$)	C/O Ext Price (\$)
Paving	43	Fill - Haul	CY	0.00	0.00	0.00	900.00	900.00	5.45	4,905.00
									Paving Sub Total (\$)	4,905.00

Summary

Source Of Funding Special Assessments
 Net Amount Change Order # 4 (\$) 4,905.00
 Previous Change Orders (\$) 37,845.00
 Original Contract Amount (\$) 302,391.31
 Total Contract Amount (\$) 345,141.31

I hereby accept this order both as to work to be performed and prices on which payment shall be based.

CONTRACT TIME

Current Substantial Completion Date	Current Final Completion Date	Additional Days Substantial Completion	Additional Days Final Completion	New Substantial Completion Date	New Final Completion Date
10/26/2018	05/08/2019	0.00	0.00	10/26/2018	05/08/2019

APPROVED

Fox Underground

APPROVED DATE

John S. Sals

5-31-19

Department Head

1-000 6/12/19



CITY OF FARGO
ENGINEERING DEPARTMENT
CHANGE ORDER REPORT

Title

Mayor

Attest

23

REPORT OF ACTION

PUBLIC WORKS PROJECTS EVALUATION COMMITTEE

Improvement District No. BR-18-E1 Type: Change Order #4
Location: Great Northern Drive Date of Hearing: 6/10/2019

Routing Date
City Commission 6/17/2019
PWPEC File X
Project File Roger Kluck

The Committee reviewed the accompanying correspondence from Project Manager, Roger Kluck, for Change Order #4 in the amount of \$368.08 for additional work, bringing the total contract amount to \$2,275,092.30. XCEL Energy will reimburse the City for costs relating to Change Order #4.

Staff is recommending approval of Change Order #4.

On a motion by Bruce Grubb, seconded by Kent Costin, the Committee voted to recommend approval of Change Order #4 in the amount of \$368.08 to Dakota Underground.

RECOMMENDED MOTION

Approve Change Order #4 in the amount of \$368.08 to Dakota Underground.

PROJECT FINANCING INFORMATION:

Recommended source of funding for project: Infrastructure Sales Tax/XCEL Reimbursement

Table with 2 columns: Question, Yes/No. Rows include Developer meets City policy for payment of delinquent specials, Agreement for payment of specials required of developer, 50% escrow deposit required.

COMMITTEE

Table with 5 columns: Name, Present, Yes, No, Unanimous. Lists committee members and their voting status.

ATTEST:

Handwritten signature of Brenda E. Derrig, P.E.
Brenda E. Derrig, P.E.
City Engineer

C: Kristi Olson

Memorandum

To: Members of PWPEC

From: Roger E. Kluck, PE, CFM Civil Engineer II

Date: June 6, 2019

Re: Improvement District No. BR-18-E1 – Change Order #4
Water Main Replacement, Storm Sewer Replacement, Street Reconstruction & Incidentals

Background:

Improvement District No. BR-18-E1 was bid on April 18, 2018, and was awarded to Dakota Underground by City Commission. Construction began on May 7, 2018. This project consists of storm sewer relocation on Great Northern Drive from 25th Street North to 17th Street North and water main relocation on 17th Street North from Great Northern Drive/8th Avenue North to 7th Avenue North. The storm sewer along the north side of Great Northern Drive is being moved from the boulevard into the street. On 17th Street, the water main in the west boulevard is also being moved into the street. This work is being done to clear a path for XCEL Energy to bring a new high voltage power line to Fargo. XCEL Energy will reimburse the City for the costs relating to clearing the boulevards of utilities and restoring the street. In addition to reconstructing the north half of Great Northern Drive for the storm sewer relocation, the south half of the street will be reconstructed and sidewalk will be added from 25th Street to 21st Street.

This Change Order #4 (attached) covers the costs associated with replacing two inlet grates that were damaged over the winter by snow removal. Last fall it froze in before the Contractor could complete the punchlist items. The project was held over until this spring and these two inlets were found to be damaged. The summarized cost is \$368.08. XCEL Energy will be reimbursing the City for this Change Order #4 because the inlets were installed as part of the XCEL requested relocation of the storm water main line from the north boulevard into the street. Engineering feels the price requested is reasonable.

Recommended Motion:

Approve Change Order #4 in the amount of \$368.08 to Dakota Underground Co., Inc.

JTS/klb
Attachment

C: Brenda Derrig, City Engineer
Tom Knakmuhs, Assistant City Engineer
Jody Bertrand, Division Engineer

FERGUSON
WATERWORKS
 1917 1ST AVE N
 FARGO, ND 58102-4118

Please contact with Questions: 888-873-5685

INVOICE NUMBER	TOTAL DUE	CUSTOMER	PAGE
0326657	\$294.46	376	1 of 1

PLEASE REFER TO INVOICE NUMBER WHEN
 MAKING PAYMENT AND REMIT TO:

FERGUSON WATERWORKS #2516
 PO BOX 802817
 CHICAGO, IL 60680-2817

SHIP TO:

DAKOTA UNDERGROUND CO
 4001 15TH AVENUE NW
 WEST FARGO, ND 58078

COUNTER PICK UP
 1917 1ST AVE N
 FARGO, ND 58102-4118

SHIP WHSE.	SELL WHSE.	TAX CODE	CUSTOMER ORDER NUMBER	SALESMAN	JOB NAME	INVOICE DATE	BATCH
2516	2516	ND105	GREAT NORTHERN DR	LR	DAVID	05/20/19	IO 19265
ORDERED	SHIPPED	ITEM NUMBER	DESCRIPTION	UNIT PRICE	UM	AMOUNT	
2	2	E007030031	Thank you for your business! 7030M7 BD VANE GRATE	136.960	EA	273.92	
			INVOICE SUB-TOTAL			273.92	
			TAX	Fargo		20.54	
LEAD LAW WARNING: IT IS ILLEGAL TO INSTALL PRODUCTS THAT ARE NOT "LEAD FREE" IN ACCORDANCE WITH US FEDERAL OR OTHER APPLICABLE LAW IN POTABLE WATER SYSTEMS ANTICIPATED FOR HUMAN CONSUMPTION PRODUCTS WITH *NP IN THE DESCRIPTION ARE NOT LEAD FREE AND CAN ONLY BE INSTALLED IN NON-POTABLE APPLICATIONS. BUYER IS SOLELY RESPONSIBLE FOR PRODUCT SELECTION.							294.46
							+ 25% Markup
							\$368.98

Thank you for your business 

TERMS: NET 10TH PROX	ORIGINAL INVOICE	TOTAL DUE	\$294.46
----------------------	------------------	-----------	----------

All past due amounts are subject to a service charge of 1.5% per month, or the maximum allowed by law, if lower. If Buyer fails to pay within terms, then in addition to other remedies, Buyer agrees to pay Seller all costs of collection, including reasonable attorney fees. Complete terms and conditions are available upon request or at <https://www.ferguson.com/content/website-info/terms-of-sale>, incorporated by reference. Seller may convert checks to ACH.



**CITY OF FARGO
ENGINEERING DEPARTMENT
CHANGE ORDER REPORT**

Improvement District No BR-18-E1 Change Order No 4
 Project Name Water Main Replacement, Storm Sewer Replacement, Street Reconstruction & Incidentals
 Date Entered 6/6/2019 For Dakota Underground Co Inc

This change is made under the terms of or is supplemental to your present contract, if and when approved, you are ordered to perform the work in accordance with the additions, changes, or alterations hereinafter described.

EXPLANATION OF CHANGE: Replace damaged inlet grates
 It was found over the winter that two of the new inlet grates were damaged by snow traffic removal. With the project still open and uncompleted it made sense to have the grates replaced.

Section	Line No	Item Description	Unit	Orig Cont Qty	Prev C/O Qty	Prev Cont Qty	Curr C/O Qty	Tot Cont Qty	Unit Price (\$)	C/O Ext Price (\$)
Storm Sewer	127	Repair Inlet	EA	0.00	0.00	0.00	2.00	2.00	184.04	368.08
Storm Sewer Sub Total (\$)										
368.08										

Summary
 Source Of Funding General Infrastructure Funds - 401
 Net Amount Change Order # 4 (\$) 368.08
 PreVIOUS Change Orders (\$) 93,099.42
 Original Contract Amount (\$) 2,181,624.80
 Total Contract Amount (\$) 2,275,092.30

I hereby accept this order both as to work to be performed and prices on which payment shall be based.

CONTRACT TIME

Current Substantial Completion Date	Current Final Completion Date	Additional Days Substantial Completion	Additional Days Final Completion	New Substantial Completion Date	New Final Completion Date
10/15/2018		0.00	240.00	10/15/2018	

Description

APPROVED

Bob Johnson 6/6/19
 For Contractor Dakota Underground Company

APPROVED DATE

Department Head
 [Signature] 6/12/19



CITY OF FARGO
ENGINEERING DEPARTMENT
CHANGE ORDER REPORT

Title

Project Manager

Mayor

Attest

REPORT OF ACTION

PUBLIC WORKS PROJECTS EVALUATION COMMITTEE

Improvement District No. BN-18-B1 Type: Final Balancing Change Order #2

Location: Grayland First Addition Date of Hearing: 6/10/2019

<u>Routing</u>	<u>Date</u>
City Commission	<u>6/17/2019</u>
PWPEC File	<u>X</u>
Project File	<u>Jason Satterlund</u>

The Committee reviewed the accompanying correspondence from Project Manager, Jason Satterlund, for Final Balancing Change Order #2 in the amount of \$8,161.81, bringing the total contract amount to \$1,401,987.41.

Staff is recommending approval of Final Balancing Change Order #2, in the amount of \$8,161.81.

On a motion by Bruce Grubb, seconded by Kent Costin, the Committee voted to recommend approval of Final Balancing Change Order #2.

RECOMMENDED MOTION

Concur with the recommendations of PWPEC and approve Final Balancing Change Order #2 in the amount of \$8,161.81 bringing the total contract amount to \$1,401,987.41.

PROJECT FINANCING INFORMATION:

Recommended source of funding for project: Special Assessments

	<u>Yes</u>	<u>No</u>
Developer meets City policy for payment of delinquent specials	<u>N/A</u>	<u> </u>
Agreement for payment of specials required of developer	<u>N/A</u>	<u> </u>
Letter of Credit required (per policy approved 5-28-13)	<u>N/A</u>	<u> </u>

COMMITTEE

	<u>Present</u>	<u>Yes</u>	<u>No</u>	<u>Unanimous</u>
Tim Mahoney, Mayor	<u> </u>	<u> </u>	<u> </u>	<u> </u>
Nicole Crutchfield, Director of Planning	<u> </u>	<u> </u>	<u> </u>	<u> </u>
Steve Dirksen, Fire Chief	<u> </u>	<u> </u>	<u> </u>	<u> </u>
Bruce Grubb, City Administrator	<u> </u>	<u> </u>	<u> </u>	<u> </u>
Ben Dow, Director of Operations	<u> </u>	<u> </u>	<u> </u>	<u> </u>
Steve Sprague, City Auditor	<u> </u>	<u> </u>	<u> </u>	<u> </u>
Brenda Derrig, City Engineer	<u> </u>	<u> </u>	<u> </u>	<u> </u>
Kent Costin, Finance Director	<u> </u>	<u> </u>	<u> </u>	<u> </u>

ATTEST:

C: Kristi Olson

Brenda E. Derrig
 Brenda E. Derrig, P.E.
 Division Engineer

Memorandum

To: Members of PWPEC
From: Jason Satterlund, Project Manager
Date: June 4, 2019
Re: Improvement District No. BN-18-B1 – Final Balancing Change Order #2

Background:

Improvement District No. BN-18-B1 is to provide underground utilities, asphalt paving, and street lights for Grayland 1st Addition and for the West Fargo Elementary School in Deer Creek.

Attached is Final Balancing Change Order #2 in the amount of \$8,161.81 for Improvement District No. BN-18-B1 that reconciles the estimated quantities used in the contract with the final quantities as measured in the field.

The original contract bid price for this project was \$1,379,595.60. Change Order #1 was for additional rear yard storm sewer in the amount of \$14,230.00 for a revised contract amount of \$1,393,825.60. This FBCO will bring the project final amount to \$1,401,987.41 (1.01% increase). Improvement District BN-18-B1 is funded by 100% special assessments.

Recommended Motion:

Approve Final Balancing Change Order #2 in the amount of \$8,161.81 to Dakota Underground Co., Inc.

JTS/jmg
Attachment

C: Thomas Knakmuhs



CITY OF FARGO
ENGINEERING DEPARTMENT
CHANGE ORDER REPORT

Improvement District No	BN-18-B1	Change Order No	2
Project Name	Sanitary Sewer, Water Main, Storm Sewer, Paving, Street Lights & Incidentals		
Date Entered	6/4/2019	For	Dakota Underground Co Inc

This change is made under the terms of or is supplemental to your present contract, if and when approved, you are ordered to perform the work in accordance with the additions, changes, or alterations hereinafter described.

EXPLANATION OF CHANGE: Final Balancing

This change order reconciles the estimated quantities used in the contract with the final quantities as measured in the field.

Section	Line No	Item Description	Unit	Orig Cont Qty	Prev C/O Qty	Prev Cont Qty	Curr C/O Qty	Tot Cont Qty	Unit Price (\$)	C/O Ext Price (\$)
Miscellaneous	2	Mulching Type 2 - Straw	SY	13,000.00	0.00	13,000.00	-3,500.00	9,500.00	0.10	-350.00
	3	Seeding Type C	SY	13,000.00	0.00	13,000.00	-13,000.00	0.00	0.20	-2,600.00
	4	Sediment Control Log 10" to 15" Dia	LF	65.00	0.00	65.00	-65.00	0.00	5.00	-325.00
Miscellaneous Sub Total (\$)										
	8	F&I 1-1/4" Trench Found Rock 4" thru 12" Dia	LF	2,240.00	0.00	2,240.00	-2,240.00	0.00	0.01	-22.40
Sanitary Sewer	13	F&I Pipe SDR 26 - 6" Dia PVC	LF	1,750.00	0.00	1,750.00	-25.00	1,725.00	15.00	-375.00
	14	F&I Pipe SDR 26 - 8" Dia PVC	LF	930.00	0.00	930.00	-2.32	927.68	30.00	-69.60
	15	F&I Pipe SDR 26 - 12" Dia PVC	LF	115.00	0.00	115.00	0.60	115.60	65.00	39.00
	16	F&I Pipe SDR 35 - 12" Dia PVC	LF	1,265.00	0.00	1,265.00	-1.34	1,263.66	35.00	-46.90
	18	Bore Pipe SDR 26 - 12" Dia PVC	LF	80.00	0.00	80.00	5.00	85.00	100.00	500.00
Sanitary Sewer Sub Total (\$)										
	21	F&I Hydrant	EA	6.00	0.00	6.00	1.00	7.00	4,000.00	28,000.00
	22	Relocate Hydrant	EA	1.00	0.00	1.00	-0.50	0.50	1,500.00	-750.00
	23	F&I Pipe C900 DR 18 - 6" Dia PVC	LF	145.00	0.00	145.00	-10.00	135.00	21.00	-2,835.00
	24	F&I Pipe w/GB C900 DR 18 - 6" Dia PVC	LF	33.00	0.00	33.00	2.00	35.00	30.00	60.00
	25	F&I Pipe C900 DR 18 - 8" Dia PVC	LF	2,305.00	0.00	2,305.00	-11.51	2,293.49	21.00	-47,171.00
	26	F&I Restr Joint Pipe C900 DR 18 - 8" Dia PVC	LF	285.00	0.00	285.00	5.41	290.41	42.00	12,242.20



**CITY OF FARGO
ENGINEERING DEPARTMENT
CHANGE ORDER REPORT**

Item #	Description	Unit	QTY	Unit Price	Amount	Change	Sub Total	Sub Total (\$)
28	F&I Pipe w/GB C900 DR 18 - 12" Dia PVC	LF	13.00	0.00	13.00	-5.50	7.50	70.00
30	F&I Gate Valve 8" Dia	EA	6.00	0.00	6.00	-1.00	5.00	1,450.00
33	F&I Pipe 1" Dia Copper	LF	1,415.00	0.00	1,415.00	-2.00	1,413.00	15.00
Cass Rural Water Sub Total (\$)								
								1,220.51
38	F&I Manhole 4' Dia Reinf Conc	EA	5.00	1.00	6.00	-1.00	5.00	2,450.00
41	F&I Manhole 7' Dia Reinf Conc	EA	3.00	0.00	3.00	1.00	4.00	8,500.00
44	F&I Pipe 12" Dia	LF	320.00	290.00	610.00	-6.92	603.08	22.00
45	F&I Pipe 12" Dia Reinf Conc	LF	55.00	0.00	55.00	-2.80	52.20	38.00
46	F&I Pipe w/GB 12" Dia Reinf Conc	LF	340.00	0.00	340.00	-3.00	337.00	45.00
47	F&I Pipe 15" Dia Reinf Conc	LF	370.00	0.00	370.00	-4.11	365.89	40.00
48	F&I Pipe 21" Dia Reinf Conc	LF	120.00	0.00	120.00	-1.57	118.43	48.00
49	F&I Pipe 24" Dia Reinf Conc	LF	335.00	0.00	335.00	-14.00	321.00	51.00
50	F&I Pipe 30" Dia Reinf Conc	LF	245.00	0.00	245.00	-2.00	243.00	75.00
51	F&I Pipe 36" Dia	LF	440.00	0.00	440.00	-2.53	437.47	95.00
52	F&I Pipe 36" Dia Reinf Conc	LF	535.00	0.00	535.00	0.29	535.29	95.00
53	F&I Pipe w/GB 36" Dia Reinf Conc	LF	100.00	0.00	100.00	-2.00	98.00	115.00
54	F&I Pipe 42" Dia Reinf Conc	LF	140.00	0.00	140.00	-1.00	139.00	149.00
96	* Relocate Tree	LS	0.00	0.00	0.00	1.00	1.00	412.50
Storm Sewer Sub Total (\$)								
								4,373.30
57	Excavation	CY	20,500.00	0.00	20,500.00	2,884.00	23,384.00	4.00
58	Subcut	CY	3,200.00	0.00	3,200.00	-3,200.00	0.00	0.01
63	F&I Edge Drain 4" Dia PVC	LF	4,555.00	0.00	4,555.00	-39.10	4,515.90	6.00
64	F&I Curb & Gutter Mountable (Type I)	LF	3,385.00	0.00	3,385.00	38.50	3,423.50	12.00
65	F&I Curb & Gutter Standard (Type II)	LF	1,170.00	0.00	1,170.00	-139.60	1,030.40	14.00
67	F&I Valley Gutter Reinf Conc	SY	52.00	0.00	52.00	12.81	64.81	70.00
68	F&I Shared Use Path 4" Thick Reinf Conc	SY	1,970.00	0.00	1,970.00	-126.78	1,843.22	36.00
69	F&I Shared Use Path 6" Thick Reinf Conc	SY	65.00	0.00	65.00	-5.45	59.55	40.00
Paving								
57	Excavation	CY	20,500.00	0.00	20,500.00	2,884.00	23,384.00	4.00
58	Subcut	CY	3,200.00	0.00	3,200.00	-3,200.00	0.00	0.01
63	F&I Edge Drain 4" Dia PVC	LF	4,555.00	0.00	4,555.00	-39.10	4,515.90	6.00
64	F&I Curb & Gutter Mountable (Type I)	LF	3,385.00	0.00	3,385.00	38.50	3,423.50	12.00
65	F&I Curb & Gutter Standard (Type II)	LF	1,170.00	0.00	1,170.00	-139.60	1,030.40	14.00
67	F&I Valley Gutter Reinf Conc	SY	52.00	0.00	52.00	12.81	64.81	70.00
68	F&I Shared Use Path 4" Thick Reinf Conc	SY	1,970.00	0.00	1,970.00	-126.78	1,843.22	36.00
69	F&I Shared Use Path 6" Thick Reinf Conc	SY	65.00	0.00	65.00	-5.45	59.55	40.00



**CITY OF FARGO
ENGINEERING DEPARTMENT
CHANGE ORDER REPORT**

Item #	Description	SY	410.00	0.00	410.00	7.81	417.81	38.00	296.78
70	F&I Sidewalk 4" Thick Reinf Conc	SY	410.00	0.00	410.00	7.81	417.81	38.00	296.78
71	F&I Sidewalk 6" Thick Reinf Conc	SY	35.00	0.00	35.00	2.05	37.05	40.00	82.00
72	F&I Det Warn Panels Cast Iron	SF	194.00	0.00	194.00	-7.50	186.50	35.00	-262.50
73	F&I Driveway 7" Thick Reinf Conc	SY	240.00	0.00	240.00	4.03	244.03	50.00	201.50
74	F&I Aggregate for Asph Pavement FAA 43	TON	3,070.00	0.00	3,070.00	25.94	3,095.94	36.00	933.84
75	F&I Asphalt Cement PG 58-34	GAL	40,120.00	0.00	40,120.00	-121.46	39,998.54	2.10	-255.07
80	Mulching Type 1 - Hydro	SY	13,600.00	0.00	13,600.00	-8,556.00	5,044.00	0.30	-2,566.80
81	Seeding Type C	SY	13,600.00	0.00	13,600.00	-8,556.00	5,044.00	0.20	-1,711.20
99	* Grade new rear yards	LS	0.00	0.00	0.00	1.00	1.00	1,734.38	1,734.38
							Paving Sub Total (\$)		4,344.55
84	F&I Sign Assembly & Anchor	EA	10.00	0.00	10.00	1.00	11.00	155.00	155.00
86	F&I Diamond Grade Cubed	SF	37.20	0.00	37.20	6.00	43.20	20.00	120.00
							Signing Sub Total (\$)		275.00
90	F&I Innerduct 1.5" Dia	LF	3,526.00	0.00	3,526.00	102.00	3,628.00	7.50	765.00
93	F&I Conductor #6 USE Cu	LF	9,282.00	0.00	9,282.00	321.00	9,603.00	1.35	433.35
							Street Lighting Sub Total (\$)		1,198.35
							Grand Total (\$)		8,161.81

* NC Items

Summary

Source Of Funding

Net Amount Change Order # 2 (\$)	8,161.81
Previous Change Orders (\$)	14,230.00
Original Contract Amount (\$)	1,379,595.60
Total Contract Amount (\$)	1,401,987.41

I hereby accept this order both as to work to be performed and prices on which payment shall be based.

CONTRACT TIME

Current Substantial Completion Date	Current Final Completion Date	Additional Days Substantial Completion	Additional Days Final Completion	New Substantial Completion Date	New Final Completion Date



CITY OF FARGO
ENGINEERING DEPARTMENT
CHANGE ORDER REPORT

09/24/2018

0.00

0.00

09/24/2018

Description

APPROVED

Bob Johnson
For Contractor
Dakota Underground Company
Title *Project Manager*

6/4/19

APPROVED DATE

Department Head
F. Cole
Mayor *6/12/19*

Attest

25

REPORT OF ACTION

PUBLIC WORKS PROJECTS EVALUATION COMMITTEE

Improvement District No. BN-18-J1 Type: Final Balancing Change Order #3

Location: Rocking Horse Farms 5th Addition Date of Hearing: 6/10/2019

<u>Routing</u>	<u>Date</u>
City Commission	<u>6/17/2019</u>
PWPEC File	<u>X</u>
Project File	<u>Jason Leonard</u>

The Committee reviewed the accompanying correspondence from Project Manager, Jason Leonard, for Final Balancing Change Order #3 in the amount of \$784.87, bringing the total contract amount to \$1,091,601.42.

Staff is recommending approval of Final Balancing Change Order #3, in the amount of \$784.87.

On a motion by Bruce Grubb, seconded by Kent Costin, the Committee voted to recommend approval of Final Balancing Change Order #3.

RECOMMENDED MOTION

Concur with the recommendations of PWPEC and approve Final Balancing Change Order #3 in the amount of \$784.87 bringing the total contract amount to \$1,091,601.42.

PROJECT FINANCING INFORMATION:

Recommended source of funding for project: Cass Rural WUD Funds & Special Assessments

	<u>Yes</u>	<u>No</u>
Developer meets City policy for payment of delinquent specials	<u>N/A</u>	<u> </u>
Agreement for payment of specials required of developer	<u>N/A</u>	<u> </u>
Letter of Credit required (per policy approved 5-28-13)	<u>N/A</u>	<u> </u>

COMMITTEE

	<u>Present</u>	<u>Yes</u>	<u>No</u>	<u>Unanimous</u>
				<u> <input checked="" type="checkbox"/> </u>
Tim Mahoney, Mayor	<u> <input type="checkbox"/> </u>	<u> <input type="checkbox"/> </u>	<u> <input type="checkbox"/> </u>	
Nicole Crutchfield, Director of Planning	<u> <input checked="" type="checkbox"/> </u>	<u> <input checked="" type="checkbox"/> </u>	<u> <input type="checkbox"/> </u>	
Steve Dirksen, Fire Chief	<u> <input checked="" type="checkbox"/> </u>	<u> <input checked="" type="checkbox"/> </u>	<u> <input type="checkbox"/> </u>	
Bruce Grubb, City Administrator	<u> <input checked="" type="checkbox"/> </u>	<u> <input checked="" type="checkbox"/> </u>	<u> <input type="checkbox"/> </u>	
Ben Dow, Director of Operations	<u> <input type="checkbox"/> </u>	<u> <input type="checkbox"/> </u>	<u> <input type="checkbox"/> </u>	
Steve Sprague, City Auditor	<u> <input type="checkbox"/> </u>	<u> <input type="checkbox"/> </u>	<u> <input type="checkbox"/> </u>	
Brenda Derrig, City Engineer	<u> <input checked="" type="checkbox"/> </u>	<u> <input checked="" type="checkbox"/> </u>	<u> <input type="checkbox"/> </u>	
Kent Costin, Finance Director	<u> <input checked="" type="checkbox"/> </u>	<u> <input checked="" type="checkbox"/> </u>	<u> <input type="checkbox"/> </u>	

ATTEST:

C: Kristi Olson

B. E. D.
 Brenda E. Derrig, P.E.
 Division Engineer

Memorandum

To: PWPEC

From: Jason Leonard, Civil Engineer II

Date: June 3, 2019

Re: Improvement District No. BN-18-J1 – Final Balancing Change Order #3

Background:

Improvement District BN-18-J1 is an underground utility and asphalt paving project located within the Rocking Horse Farms 5th Addition.

The attached Final Balancing Change Order #3 in the amount of \$784.87, reconciles the estimated quantities used in the contract with the final quantities as measured in the field.

The original contract bid price for this project was \$1,075,688.62 and this FBCO will bring the project final amount to \$1,091,601.42 (1.48% Increase). This Improvement District is 100% Special Assessed.

Recommended Motion:

Approve Final Balancing Change Order #3 in the amount of \$784.87 to Dakota Underground.

Attachment

Improvement District No	BN-18-J1	Change Order No	3
Project Name	Sanitary Sewer, Water Main, Storm Sewer, Concrete Curb & Gutter, Asphalt Pavement, Lighting & Incide		
Date Entered	5/28/2019	For	Dakota Underground Co Inc

This change is made under the terms of or is supplemental to your present contract, if and when approved, you are ordered to perform the work in accordance with the additions, changes, or alterations hereinafter described.

EXPLANATION OF CHANGE: FINAL BALANCING CHANGE ORDER

This change order reconciles the estimated quantities used in the contract with the final quantities as measured in the field.

Section	Line No	Item Description	Unit	Orig Cont Qty	Prev C/O Qty	Prev Cont Qty	Curr C/O Qty	Tot Cont Qty	Unit Price (\$)	C/O Ext Price (\$)
Miscellaneous	1	Mulching Type 1 - Hydro	SY	23,716.00	0.00	23,716.00	6,139.69	29,855.69	0.30	1,841.91
	2	Seeding Type B	SY	23,716.00	0.00	23,716.00	-5,960.31	17,755.69	0.20	-1,192.06
	5	Silt Fence - Standard	LF	3,140.00	0.00	3,140.00	361.00	3,501.00	1.90	685.90
								Miscellaneous Sub Total (\$)		1,335.75
Sanitary Sewer	8	F&I 1-1/4" Trench Found Rock 4" thru 12" Dia	LF	1,590.00	0.00	1,590.00	-1,490.00	100.00	0.01	-14.90
	11	F&I Pipe SDR 26 - 6" Dia PVC	LF	2,220.00	0.00	2,220.00	48.00	2,268.00	20.00	960.00
								Sanitary Sewer Sub Total (\$)		945.10
Cass Rural Water District Water Main	15	F&I Fittings C153 Ductile Iron	LB	658.00	0.00	658.00	-84.00	574.00	4.00	-336.00
	17	F&I Pipe C900 DR 18 - 6" Dia PVC	LF	17.00	0.00	17.00	2.00	19.00	25.00	50.00
	18	F&I Pipe C900 DR 18 - 8" Dia PVC	LF	1,736.00	0.00	1,736.00	24.00	1,760.00	25.00	600.00
	24	F&I Pipe 1" Dia Copper	LF	2,244.00	0.00	2,244.00	-3.00	2,241.00	15.50	-46.50
								Cass Rural Water District Water Main Sub Total (\$)		267.50
Storm Sewer	27	F&I 1-1/4" Trench Found Rock 14" thru 24" Dia	LF	1,434.00	0.00	1,434.00	-1,434.00	0.00	0.01	-14.34
	28	F&I 1-1/4" Trench Found Rock 27" thru 36" Dia	LF	362.00	0.00	362.00	-362.00	0.00	0.01	-3.62
	29	F&I 1-1/4" Trench Found Rock 42" thru 54" Dia	LF	41.00	0.00	41.00	-41.00	0.00	0.01	-0.41
	38	Connect Pipe to Exist Structure	EA	2.00	0.00	2.00	1.00	3.00	500.00	500.00
	39	F&I Pipe SDR 26 - 12" Dia PVC	LF	945.00	0.00	945.00	0.16	945.16	28.00	4.48

CITY OF FARGO
ENGINEERING DEPARTMENT
CHANGE ORDER REPORT

Storm Sewer	42	F&I Pipe 18" Dia Reinf Conc	LF	188.00	0.00	188.00	-0.10	187.90	40.00	-4.00
	44	F&I Pipe 36" Dia Reinf Conc	LF	362.00	0.00	362.00	0.42	362.42	110.00	46.20
	45	F&I Pipe 48" Dia Reinf Conc	LF	41.00	0.00	41.00	0.19	41.19	155.00	29.45
	47	F&I Pipe w/GB 15" Dia Reinf Conc	LF	138.00	0.00	138.00	-0.59	137.41	45.00	-26.55
									Storm Sewer Sub Total (\$)	531.21
									20,000.00	4,000.00
Paving	52	Topsoil - Strip	LS	1.00	0.00	1.00	0.20	1.20	3.50	1,750.00
	53	Excavation	CY	18,821.00	0.00	18,821.00	500.00	19,321.00	5.00	185.00
	54	Subcut	CY	2,138.00	0.00	2,138.00	33.00	2,171.00	1.50	144.00
	55	Subgrade Preparation	SY	6,415.00	0.00	6,415.00	96.00	6,511.00	1.65	158.40
	56	F&I Woven Geotextile	SY	6,415.00	0.00	6,415.00	96.00	6,511.00	6.00	576.00
	57	F&I Class 5 Agg - 7" Thick	SY	6,415.00	0.00	6,415.00	-2.00	3,457.00	6.00	-12.00
	58	F&I Edge Drain 4" Dia PVC	LF	3,459.00	0.00	3,459.00	-2.00	3,504.00	14.00	-28.00
	59	F&I Curb & Gutter Mountable (Type I)	LF	3,506.00	0.00	3,506.00	15.00	307.00	5.00	75.00
	60	Remove Curb & Gutter	LF	292.00	0.00	292.00	-5.00	1,114.00	36.00	-180.00
	61	F&I Sidewalk 4" Thick Reinf Conc	SY	1,119.00	0.00	1,119.00	-27.50	87.50	45.00	-1,237.50
	62	F&I Sidewalk 6" Thick Reinf Conc	SY	115.00	0.00	115.00	36.67	249.67	10.00	366.70
	63	Remove Sidewalk 4" Thick Conc	SY	213.00	0.00	213.00	-23.00	188.00	40.00	-920.00
	64	F&I Det Warn. Panels Cast Iron	SF	211.00	0.00	211.00	-101.92	1,709.08	40.00	-4,076.80
	65	F&I Aggregate for Asph Pavement FAA 43	TON	1,811.00	0.00	1,811.00	-3,805.66	22,244.34	1.80	-6,850.19
	66	F&I Asphalt Cement PG 58-34	GAL	26,050.00	0.00	26,050.00	500.00	1,204.00	6.50	3,250.00
	76	Fill - Impervious	CY	704.00	0.00	704.00				
								Paving Sub Total (\$)		-2,819.39
Street Lighting	77	F&I Pull Box	EA	2.00	0.00	2.00	-1.00	1.00	1,500.00	-1,500.00
	78	F&I Conductor #6 USE Cu	LF	5,082.00	0.00	5,082.00	549.00	5,631.00	1.30	713.70
	79	F&I Innerduct 1.5" Dia	LF	1,574.00	0.00	1,574.00	138.00	1,712.00	9.50	1,311.00
									Street Lighting Sub Total (\$)	524.70

Summary



CITY OF FARGO
ENGINEERING DEPARTMENT
CHANGE ORDER REPORT

Source Of Funding	
Net Amount Change Order # 3 (\$)	784.87
Previous Change Orders (\$)	15,127.93
Original Contract Amount (\$)	1,075,688.62
Total Contract Amount (\$)	1,091,601.42

I hereby accept this order both as to work to be performed and prices on which payment shall be based.

CONTRACT TIME

Current Substantial Completion Date	Current Final Completion Date	Additional Days Substantial Completion	Additional Days Final Completion	New Substantial Completion Date	New Final Completion Date
09/01/2018		0.00	0.00	09/01/2018	

Description

APPROVED

APPROVED DATE

For Contract Officer
[Signature]

Department Head
[Signature]

Title
PRESIDENT

Mayor

Attest

26

REPORT OF ACTION

PUBLIC WORKS PROJECTS EVALUATION COMMITTEE

Improvement District No. PN-19-A1

Type: Design Decisions

Location: 64 Ave S, 25 to 45 St

Date of Hearing: 5/28/2019 6/10/2019

<u>Routing</u>	<u>Date</u>
City Commission	<u>6/17/2019</u>
PWPEC File	<u>X</u>
Project File	<u>Jeremy Gorden</u>

The Committee reviewed a communication from Division Engineer, Jeremy Gorden, regarding the design of 64th Ave S and the recommendation of a preferred design alternative.

Engineering recommended selection of Alternative B1 with Option B. This alternative is a 3-lane roadway, with 10' shared use paths on both sides of the avenue, and a 4-span bridge crossing over I-29 using lightweight fill (geoform). The estimated cost for this alternative is \$27,067,392. We also plan to construct this in a way that can be widened in the future if a decision to add ramps for full interchange is desired, pending approval from NDDOT and Federal Highway Administration for interstate access.

On a motion by Nicole Crutchfield, seconded by Steve Dirksen, the Committee voted to recommend selection of Alternative B1 with Option B.

RECOMMENDED MOTION

Concur with the recommendations of PWPEC and select Alternative B1 with Option B for the design of 64th Ave S.

PROJECT FINANCING INFORMATION:

Recommended source of funding for project: N/A

	<u>Yes</u>	<u>No</u>
Developer meets City policy for payment of delinquent specials		<u>N/A</u>
Agreement for payment of specials required of developer		<u>N/A</u>
Letter of Credit required (per policy approved 5-28-13)		<u>N/A</u>

COMMITTEE

	<u>Present</u>	<u>Yes</u>	<u>No</u>	<u>Unanimous</u>
Tim Mahoney, Mayor	<input type="checkbox"/>	<input type="checkbox"/>	<input type="checkbox"/>	<input checked="" type="checkbox"/>
Nicole Crutchfield, Director of Planning	<input checked="" type="checkbox"/>	<input checked="" type="checkbox"/>	<input type="checkbox"/>	
Steve Dirksen, Fire Chief	<input checked="" type="checkbox"/>	<input checked="" type="checkbox"/>	<input type="checkbox"/>	
Bruce Grubb, City Administrator	<input checked="" type="checkbox"/>	<input checked="" type="checkbox"/>	<input type="checkbox"/>	
Ben Dow, Director of Operations	<input type="checkbox"/>	<input type="checkbox"/>	<input type="checkbox"/>	
Steve Sprague, City Auditor	<input type="checkbox"/>	<input type="checkbox"/>	<input type="checkbox"/>	
Brenda Derrig, City Engineer	<input checked="" type="checkbox"/>	<input checked="" type="checkbox"/>	<input type="checkbox"/>	
Kent Costin, Finance Director	<input checked="" type="checkbox"/>	<input checked="" type="checkbox"/>	<input type="checkbox"/>	

ATTEST:

 Brenda E. Derrig, PE
 City Engineer

May 23, 2019

To: Members of PWPEC

From: Jeremy M. Gorden, PE, PTOE
Division Engineer - Transportation

Subject: Design Decisions for 64th Avenue S Construction Project
City of Fargo Improvement District No. PN-19-A1
64th Avenue S – 25th Street to 45th Street

I've attached the relevant portions of the environmental document and the 'City Decision' page for this project and it's time for staff to recommend a preferred design alternative to the City Commission for review and approval. The Engineering Department is recommending the following for consideration to PWPEC:

Selection of Alternative #1 for the alternative to construct. This Alternative is a 3-lane roadway, with 10' shared use paths on both sides of the avenue, and a 4-span bridge crossing over I-29 using lightweight fill (geoform). Due to the nature of our soils in the Red River Valley, this bridge design is the most conservative of the three noted in the environmental document. The estimated cost for this alternative is **\$27,067,392**.

We also plan on constructing this in a way so that it can be widened in the future if a decision to add ramps for a full interchange is desired, pending approval from NDDOT and Federal Highway Administration for interstate access.

Staff believes this avenue once built will be a livable street, conducive to slower speeds, and making walking and biking more comfortable. We envision it to be very similar to how 40th Ave S functions in south Fargo.

Recommended Motion

Select Alternative #1 for this project using a 4-span bridge with lightweight fill as the bridge design.

Attachment

H. City Decisions

1. Do you concur with the project concepts as proposed?

Yes

No

2. Which alternative and which option (if any) should proceed with the project?

Alternative A: No-Build Alternative (\$0)

Alternative B1 (Base Design): Three-lane Roadway Section; Two-span Geofoam Embankment Bridge (\$27,371,922.56)

Alternative B1 with Option A: Four-span Earthen Embankment Bridge (\$25,683,429.60 = Base Design - \$1,688,492.96)

Alternative B1 with Option B: Four-span Geofoam Embankment Bridge (\$27,262,892.60 = Base Design - \$109,029.96)

Alternative B2 (Base Design): Three-lane Roadway Section with Bike Lanes; Two-span Geofoam Embankment Bridge (\$29,568,195.80)

Alternative B2 with Option A: Four-span Earthen Embankment Bridge (\$27,810,037.40 = Base Design - \$1,758,158.40)

Alternative B2 with Option B: Four-span Geofoam Embankment Bridge (\$29,123,921.40 = Base Design - \$444,274.40)

Alternative B3 (Base Design): Three-lane Section with Cycle Track; Two-span Geofoam Embankment Bridge (\$29,832,346.80)

Alternative B3 with Option A: Four-span Earthen Embankment Bridge (\$27,699,579.37 = Base Design - \$2,132,767.43)

Alternative B3 with Option B: Four-span Geofoam Embankment Bridge (\$29,879,256.80 = Base Design + \$46,910.00)

Amendments/Comments for Project No. SU-8-984(153)156:

The sidewalk on the south side should be a 10' wide.

Dr. Tim Mahoney, Mayor

6-17-19

Date

DRAFT DOCUMENTED CATEX

ROADWAY AND STRUCTURE CONSTRUCTION

Project No.
SU-8-984(153)156

PCN
21564

64th Avenue South
From 25th Street South to 45th Street South
Fargo, North Dakota

Prepared by

CITY OF FARGO
FARGO, NORTH DAKOTA

<https://fargond.gov/>

MAYOR
Dr. Tim Mahoney

Principal Author: KLJ
Environmental Reviewer: Seng Marohl, LGD
March 2019

ROADWAY AND STRUCTURE CONSTRUCTION

FARGO, NORTH DAKOTA

CERTIFICATION

I hereby certify that this report was prepared by me or under my direct supervision and that I am a duly registered professional engineer under the laws of the State of North Dakota. This document was originally issued and sealed by Scott Middaugh, Registration number PE-NUMBER on MM/DD/YY and the original document is stored at the North Dakota Department of Transportation.

This document
is preliminary
and not for
construction or
implementation
purposes.

PRELIMINARY

Scott Middaugh, P.E.

Date

Table of Contents

A.	Project Description	1
	Figure 1 – Project Location Map	1
	Table 1 - Traffic Data	2
B.	Project Schedule	2
C.	Purpose of Project	2
D.	Need for Project	2
	Figure 2 – Existing Typical Section	3
E.	Scope of Work	3
F.	Description of Alternatives	3
	a. Alternative A: No Build	3
	b. Alternative B: Build Alternative(s)	4
	Figure 3 – Alternative B Proposed Typical Sections	6
	Figure 4 – Alternative B1 Proposed Typical Sections	6
	Figure 5 – Alternative B1 Proposed Typical Sections	6
	c. Traffic Control Work Zone Safety and Mobility	7
	d. Work Zone Traffic Control	7
	e. Maintenance Responsibility Discussion	7
	f. Summary of Engineering Issues	7
	g. Summary of Environmental Issues	8
	Table 2 - Right of Way Summary	8
	Table 3 – Summary of Estimated Costs	8
G.	Comments from the Programmatic/Documented CATEX	9
H.	Public Concerns / Need for Public Input	9
	Table 4 – Summary of Comments/Responses	9
	Table 5 – Comparison of Alternatives	10
	Table 6 – Recommendations	11
I.	Executive Decisions	12
II.	Environmental Impact Checklist	13

Appendices

Appendix A	Solicitation of Views
Appendix B	Endangered Species Act
Appendix C	Wetland Information
Appendix D	Comments from the Documented CATEX

Supporting Documents

Public Involvement Report
Aquatic Resources Delineation Report
Noise Report
Cultural Resources Report

A. Project Description

Highway: 64th Avenue South, Interstate 29
District: Fargo District
Limits: 64th Avenue South: 45th Street S to 25th Street S

Associated Project PCN(s) and Description(s): PCN 21494, 21495, 21496: Interstate 29 Reconstruction

Figure 1 – Project Location Map

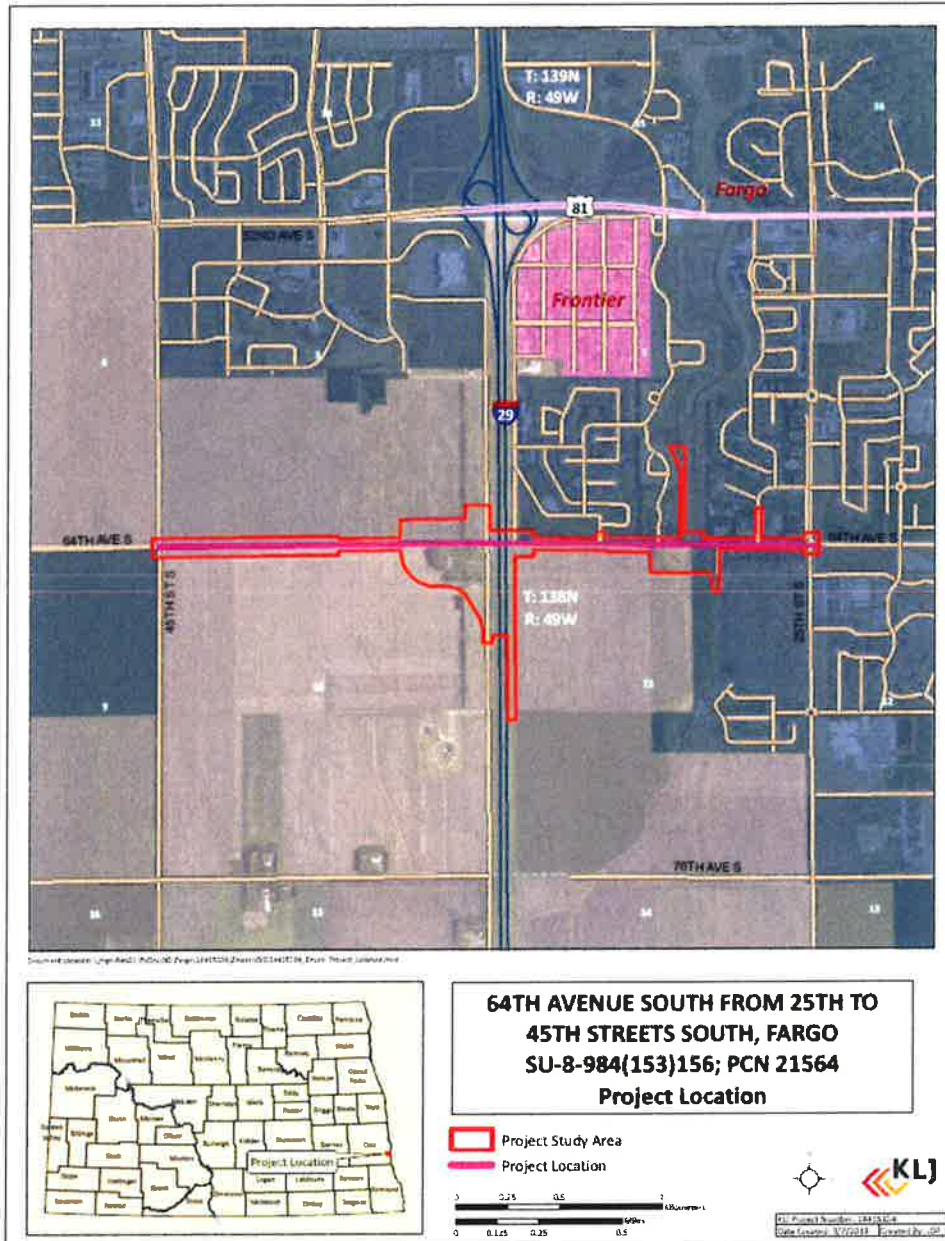

Table 1 - Traffic Data

	Year	Passengers	Trucks	Totals
64th Ave S 45th Street South to 38th Street South				
Existing ADT	2019	230	10	240
No Build ADT	2040	6,190	130	6,320
Build ADT	2040	20,780	430	21,210
64th Ave S 38th Street South to Interstate 29				
Existing ADT	2019	230	10	240
No Build ADT	2040	12,250	250	12,500
Build ADT	2040	17,240	360	17,600
64th Ave S Interstate 29 to 31st Street South				
Existing ADT	2019	400	10	410
No Build ADT	2040	3,210	70	3,280
Build ADT	2040	16,850	350	17,200
64th Ave S 31st Street South to 25th Street South				
Existing ADT	2019	540	20	560
No Build ADT	2040	3,210	70	3,280
Build ADT	2040	13,250	280	13,530

B. Project Schedule

Project: SU-8-984(153)156
Plans Complete: November 2019
Bid Opening: February 2020

C. Purpose of Project

The purpose of the project is to improve system linkage to allow for the safe and efficient movement of people and goods.

D. Need for Project

The need for the project is driven by a lack of system linkage and projected growth of the City of Fargo to the south.

Existing Conditions:

The existing 64th Avenue South between 33rd Street South and 25th Street South is a rural 2-lane gravel roadway providing access to adjacent properties and developments. The remainder of the corridor is a minimum maintenance 2-track section line roadway providing access to adjacent farmland. Existing pedestrian/bicycle facilities along 64th Avenue South consist of approximately 300 feet of shared-use path east of 31st Street South. There is no

existing connection across Interstate 29 along 64th Avenue South for motorized or non-motorized traffic. The nearest crossings are located approximately 1 mile north along 52nd Avenue South and approximately 3 miles south along 100th Avenue South (Cass County Highway 14).

Figure 2 – Existing Typical Section

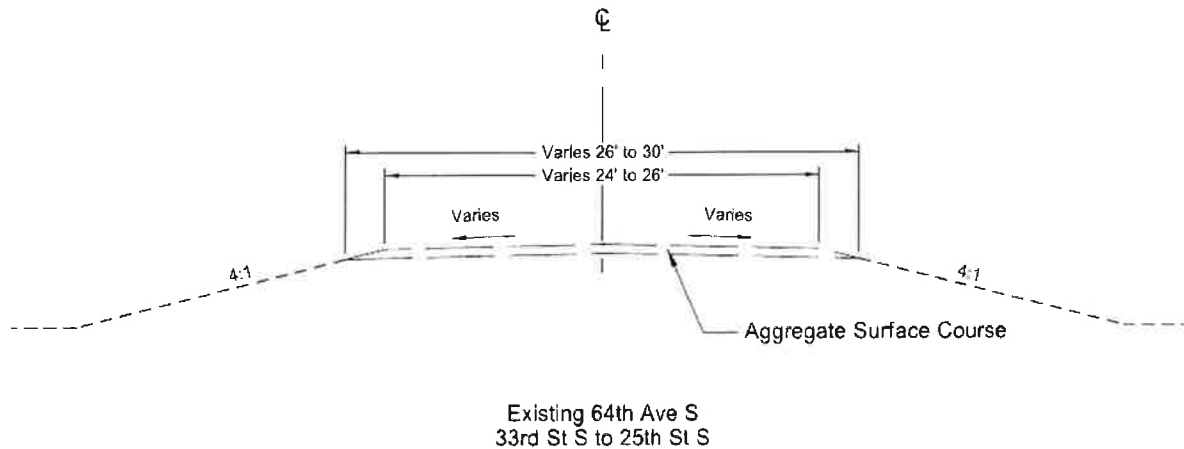

Deficiencies:

Construction of 45th Street South between 64th Avenue South and 52nd Avenue South is planned for 2020, and growth of the City of Fargo is anticipated to continue south into the future. An east-west connection between 25th Street and 45th Street along 64th Avenue South for motorized and non-motorized traffic is lacking. The project is identified in transportation planning documents, whereby 64th Avenue South is anticipated to become a minor arterial roadway. The project is needed to provide a connection along 64th Avenue South between 25th Street South and 45th Street South and to improve the corridor to an urban section with bicycle/pedestrian facilities in order to accommodate future growth of the City of Fargo.

E. Scope of Work

2019 - 2022 STIP:	\$12,416,134
2019 Documented CATEX:	\$28.7 to 30.6 million

F. Description of Alternatives

a. Alternative A: No Build

The No-Build Alternative would leave 64th Avenue South as-is, with the continuation of current maintenance practices. Under this alternative, the roadway, new overpass, and bicycle and pedestrian facilities would not be constructed/reconstructed, nor would associated improvements to City infrastructure occur (i.e., Drain 53 structure, storm drain, sanitary sewer, water

main). The No-Build alternative would not meet the defined purpose and need for the project.

b. Alternative B: Build Alternatives

The proposed project includes three build alternatives. Please refer to the discussions below and Figures 3, 4, and 5 for proposed typical sections.

Alternative B1 – Three Lane Section

Construct three lanes between 45th Street South and 25th Street South

- Construct three 11-foot driving lanes (one lane in each direction and a center turn lane), including curb and gutter
- Construct a new overpass bridge over Interstate 29 to accommodate a 12-foot shared-use path, two driving lanes (one lane in each direction), and an 8-foot sidewalk.

Alternative B2 – Three Lane Section with Bike Lanes

Construct three lanes between 45th Street South and 25th Street South with two 6-foot bike lanes

- Construct three 11-foot driving lanes (one lane in each direction and a center turn lane) and two 5-foot bike lanes with 2-foot buffer, including curb and gutter
- Construct a new overpass bridge over Interstate 29 to accommodate a 12-foot shared-use path, two driving lanes (one lane in each direction) two 5-foot bike lanes (one lane in each direction), and an 8-foot sidewalk.

Alternative B3 – Three Lane Section with Cycle Track

Construct three lanes between 45th Street South and 25th Street South

- Construct three 11-foot driving lanes (one lane in each direction and a center turn lane) with cycle track facilities at intersections, including curb and gutter
- Construct 12-foot cycle track on the south side of 64th Avenue South from 45th Street South to the east pedestrian underpass.
- Construction 10-foot shared-use path from the east pedestrian underpass to 25th Street South
- Construct a new overpass bridge over Interstate 29 to accommodate a 12-foot shared-use path, two driving lanes (one lane in each direction), and an 18-foot combined cycle track / pedestrian path.

Figure 3 – Alternative B1 Proposed Typical Section

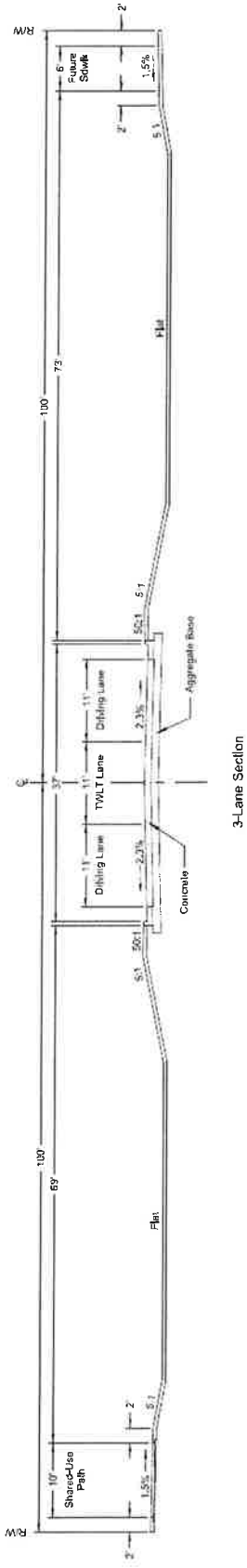

Figure 4 – Alternative B2 Proposed Typical Section

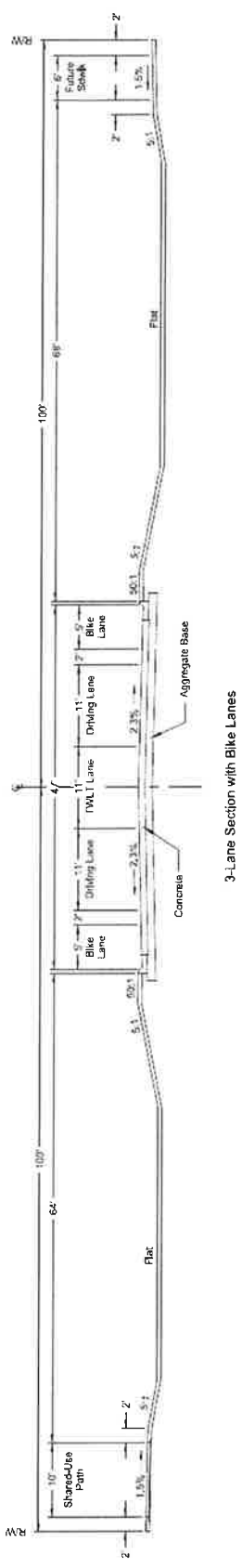
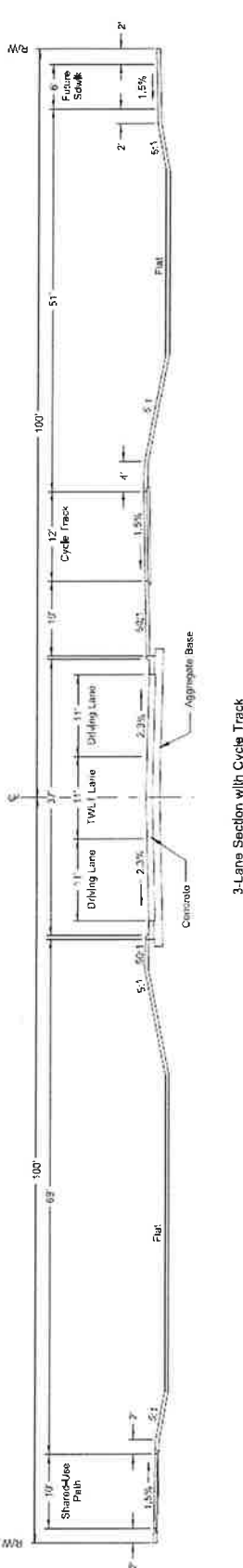

Figure 5 – Alternative B3 Proposed Typical Section



c. Traffic Control Work Zone Safety and Mobility

Project No. SU-8-984(153)156 is not designated as a significant project in the 2019-2022 STIP. The work zone traffic control plan for this project is summarized within this environmental document, in accordance with the processes outlined in the Work Zone Safety and Mobility program for non-significant projects.

d. Work Zone Traffic Control

Due to the size of the project and some geotechnical constraints, the project will be constructed in two construction seasons, 2020 and 2021. During the 2020 Construction Season, the following items will be completed:

- Completion of 64th Avenue South including pedestrian facilities, underground utilities, and Drain 53 structure from 33rd Street South to 25th Street South
- Construction of the overpass embankment surcharge on the east and west sides of Interstate 29.
- Relocation of the existing DMS sign.
- Permanent realignment of the west Interstate 29 frontage road south of 64th Avenue South
- Temporary realignment of the west Interstate 29 frontage road north of 64th Avenue South

The project corridor between 33rd Street South and 25th Street South would be closed to thru traffic during construction. Access to adjacent properties would be maintained. Detours would not be provided for this closure of 64th Avenue South.

During the 2021 Construction Season, the following items will be completed:

- Completion of 64th Avenue South including pedestrian facilities, underground utilities, and Interstate 29 overpass structure from 45th Street South to 33rd Street South
- Removal of the temporary realignment of the west Interstate 29 frontage road north of 64th Avenue South
- Removal of the overpass embankment surcharge

The project corridor between 45th Street South and 33rd Street South would be closed to thru traffic during construction. Access to adjacent properties would be maintained. Detours would not be provided for 64th Avenue South between 45th Street South to 33rd Street South. During the construction of the Interstate 29 overpass structure, the northbound and southbound lanes will have to be independently closed and detoured to perform the following tasks:

- Installation of bridge beams (two-night closure per direction of travel)
- Installation of roadway canopy (one-night closure per direction of travel)
- Removal of roadway canopy (one-night closure per direction of travel)

In total, eight closures will be required, four for northbound Interstate 29 traffic and four for southbound Interstate 29 traffic. During the Interstate 29 closures, traffic will be detoured onto 100th Avenue South (Exit 54, Cass County Highway 14), to University Drive/Cass County Highway 81, to 52nd Avenue South (Exit 60). The closure will only be allowed from 9:00 PM to 5:00 AM. The City of Fargo, NDDOT Fargo District, and Cass County Highway Department have all approved of the detour route. A Memorandum of Agreement (MOA) for the closure/detour will be

required between all parties prior to final plans. The MOA must include language stating that NDDOT is not responsible for maintenance or damages off of the state system due to the detour. Coordination regarding the closure will take place with local emergency services, schools, and the public prior to closure going into effect.

e. Maintenance Responsibility Discussion

The City of Fargo would retain ownership and maintenance of 64th Avenue South.

f. Summary of Engineering Issues

- There are several utilities within the 64th Avenue South corridor. As the design progresses, one-on-one utility meetings and coordination would be completed to determine if any impacts would occur. Mitigation for impacts would be discussed at that time.
- The embankment fill heights required for the overpass structure over Interstate 29 would be considered for geotechnical issues. A geotechnical report would be completed as part of this project to provide recommendations on surcharge requirements.
- The project is proposing the installation of two pedestrian underpass structures. Consideration for alignment, profile, drainage and geotechnical concerns would be considered.
- Connectivity of the west Interstate 29 frontage road north of 64th will be removed as part of the project. Connectivity will be re-established via 45th Street South once completed in 2020 or 2021.

g. Summary of Environmental Issues

- Tree Impacts: The projects would result in the removal of 31 trees. Tree removal would be mitigated at a 2:1 ratio according to City of Fargo standards. It is proposed that tree mitigation would take place in the new boulevard of the proposed roadway.
- Permanent aquatic resource impacts could not be avoided due to the location of aquatic resources immediately adjacent to the existing roadway. Impacts would occur due to the construction of a new overpass, widening/construction along 64th Avenue South, and installation of new sidewalk/bike/cycle path(s). Please refer to the attached aquatic resource impact tables for a breakdown of permanent and temporary impacts to aquatic resources. To ensure compliance with Section 404 of the Clean Water Act, a US Army Corps of Engineers (USACE) permit would be obtained for impacts to aquatic resources under USACE jurisdiction. Compensatory mitigation would be required for both Section 404 and EO 11990. Location and type of mitigation is pending.
- The proposed work is classified as a Type 1 Project and as such, a traffic noise analysis was conducted. No receptors associated with the project are predicted to have traffic noise impacts, as none of the calculated noise levels at the receptors approach, meet, or exceed the Noise Abatement Criteria, and no receptors are predicted to have a noise increase of at least 15 dBA over existing conditions.
- The project would require the acquisition of USACE Section 404, NDDH NDPDES, and City of Fargo Non-Building Floodplain Development permits.

Table 2 - Right of Way Summary

Alternatives	Temporary ROW Needed	Permanent ROW Needed	US Fish & Wildlife Property Interest?	US Forest Service Property Interest?
Alternative A	0.00 Acres	0.00 Acres	No	No
Alternative B1	2.95 Acres	51.71 Acres	No	No
Alternative B2	2.95 Acres	51.71 Acres	No	No
Alternative B3	2.95 Acres	51.71 Acres	No	No

Table 3 – Summary of Estimated Costs

Alternative	Estimated Cost
Alternative A – No build	\$0
Alternative B1 – 3 Lane Section	\$28,693,744.59
Alternative B2 – 3 Lane Section with Bike Lanes	\$30,649,983.70
Alternative B3 – 3 Lane Section with Cycle Track	\$30,211,778.26

G. Comments from the Documented CATEX
 PENDING - TO BE COMPLETED PRIOR TO FINAL DCE.

H. Public Concerns / Need for Public Input

In order to inform the project stakeholders and local and federal agencies of the proposed project, a Solicitation of Views package was sent to the applicable jurisdictions and public agencies on September 11, 2018. There were 16 total responses received, 15 received prior to October 11, 2018, the end of the 30-day comment period and one received after. Please refer to Appendix A, Solicitation of Views. In addition, a public input meeting for the proposed project was held on January 10, 2019 in Fargo, North Dakota.

Table 4 – Summary of Comments/Responses

Topic	Comments	Responses
Special Assessment	What will my special assessments be once project is complete?	Estimates were provided to residents who requested this information.
Interstate Access	Will an on/off ramp be included with this project?	This project does not include on and off ramps to I-29.
Property Impacts	How will access be maintained/constructed?	All private access points would be maintained at their current locations.
Property Impacts	How will the project affect drainage?	The project would maintain existing drainage patterns.

Property Impacts	How will my property be valued?	An appraiser would be involved in the project during the final design phase to assess the value of property required to be acquired by the project.
Bike Lane/sidewalk	I support a combined pedestrian/bike path.	Comment noted.
Bike Lane/sidewalk	How will the sidewalks affect my property?	ROW would be acquired as part of the project, a portion of which would be used for construction/maintenance of sidewalks. Snow removal of the sidewalks and mowing of the boulevard is the responsibility of the adjacent property owner.
Safety	Please include curves, medians or something else to slow unsafe traffic.	The alignment would follow existing travel routes and would be designed to current city, state, and federal standards.

Table 5 – Comparison of Alternatives

Alternative	Advantages	Disadvantages
Alternative A	No direct environmental impacts; no economic costs.	Does not meet the defined purpose and need; persistence of deficient conditions.
Alternative B1 – 3 Lane Alt	Meets purpose and need of the project; remediation of deficiencies.	Temporary ground disturbance; approximately 1.28 acre of permanent and 0.32 acre of temporary impacts to wetlands and 0.03 acre/113 linear feet of permanent and 0.02 acre/30 linear feet of temporary impacts to Other Waters; potential temporary water quality impacts; tree removal; requires 51.71 acres permanent and 2.95 acres temporary ROW; lowest cost build alternative.
Alternative B2 – W/Bike Lane	Meets purpose and need of the project; remediation of deficiencies; includes additional bike lane.	Temporary ground disturbance; approximately 1.30 acre of permanent and 0.32 acre of temporary impacts to wetlands and 0.03 acre/113 linear feet of permanent and 0.02 acre/30 linear feet of temporary impacts to Other Waters; potential temporary water quality impacts; tree removal; requires 51.71 acres permanent and 2.95 acres temporary ROW; highest cost build alternative.

Alternative B3 – W/Cycle Track	Meets purpose and need of the project; remediation of deficiencies; includes additional cycle track.	Temporary ground disturbance; approximately 1.33 acre of permanent and 0.32 acre of temporary impacts to wetlands and 0.03 acre/113 linear feet of permanent and 0.02 acre/30 linear feet of temporary impacts to Other Waters; potential temporary water quality impacts; tree removal; requires 51.71 acres permanent and 2.95 acres temporary ROW; lower cost than build alternative B2, but higher cost than build alternative B1.
--------------------------------	--	--

Table 6 – Recommendations

	1. Do you concur with the project concepts as proposed?	2. Which alternative(s) should proceed with the project?
Office of Project Development		
Office of Transportation Programs		
Office of Operations		
Bridge Division		
Construction Services Division		
Design Division		
District		
Environmental and Transportation Services Division		
Local Government Division		
Maintenance Division		
Materials and Research Division		
Programming Division		
Planning/Asset Management Division		
City		
FHWA		

H. City Decisions

1. Do you concur with the project concepts as proposed?

Yes

No

2. Which alternative and which option (if any) should proceed with the project?

Alternative A: No-Build Alternative (\$0)

Alternative B1 (Base Design): Three-lane Roadway Section; Two-span Geofoam Embankment Bridge (\$27,227,022.56)

Alternative B1 with Option A: Four-span Earthen Embankment Bridge (\$25,487,929.60 = Base Design - \$1,739,092.96)

Alternative B1 with Option B: Four-span Geofoam Embankment Bridge (\$27,067,392.60 = Base Design - \$159,629.96)

Alternative B2 (Base Design): Three-lane Roadway Section with Bike Lanes; Two-span Geofoam Embankment Bridge (\$29,423,295.80)

Alternative B2 with Option A: Four-span Earthen Embankment Bridge (\$27,490,337.40 = Base Design - \$1,932,958.40)

Alternative B2 with Option B: Four-span Geofoam Embankment Bridge (\$28,930,721.40 = Base Design - \$492,574.40)

Alternative B3 (Base Design): Three-lane Section with Cycle Track; Two-span Geofoam Embankment Bridge (\$29,496,546.80)

Alternative B3 with Option A: Four-span Earthen Embankment Bridge (\$27,113,079.37 = Base Design - \$2,383,467.43)

Alternative B3 with Option B: Four-span Geofoam Embankment Bridge (\$29,419,256.80 = Base Design - \$77,290.00)

Amendments/Comments for Project No. SU-8-984(153)156:

Dr. Tim Mahoney, Mayor

Date

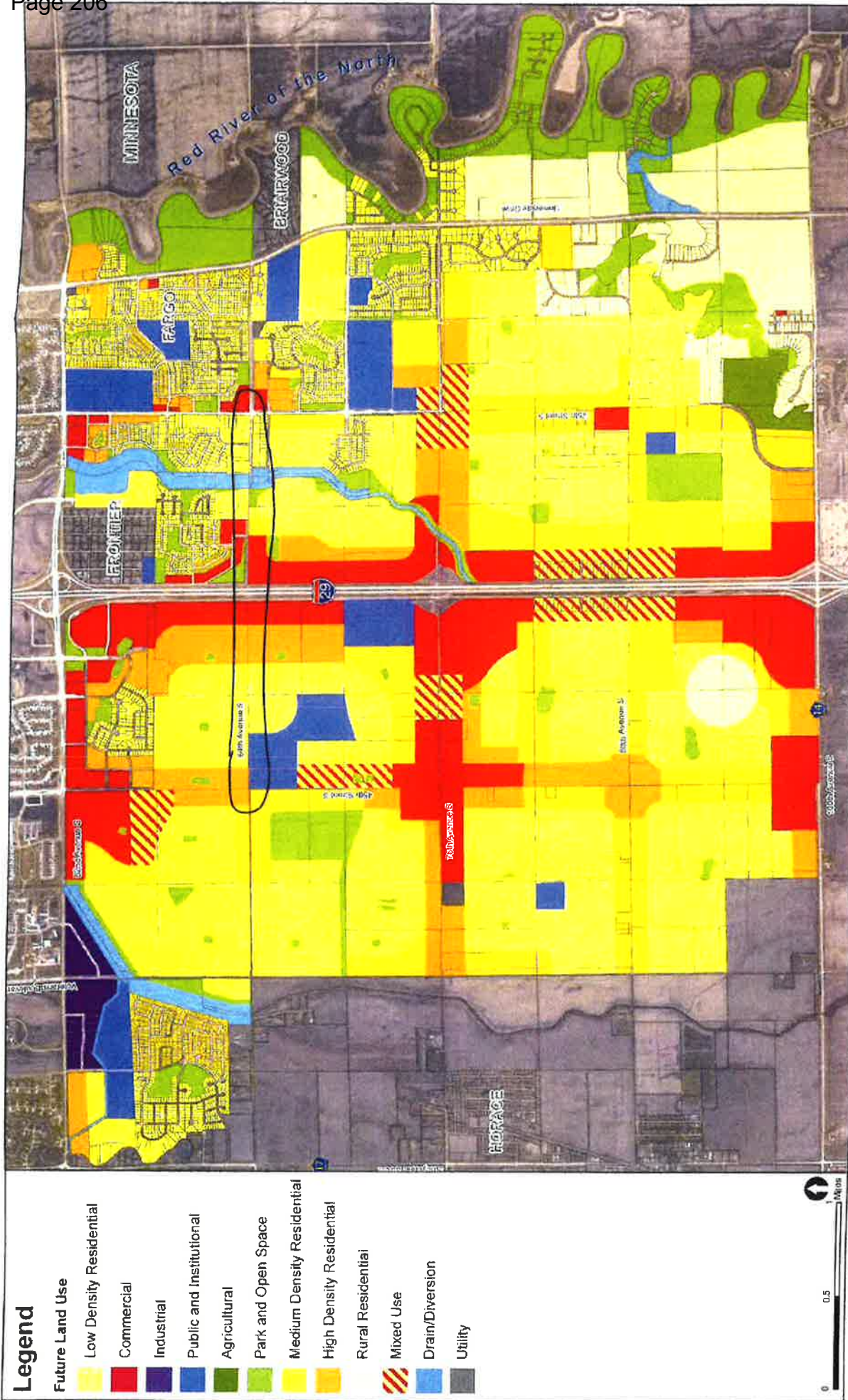
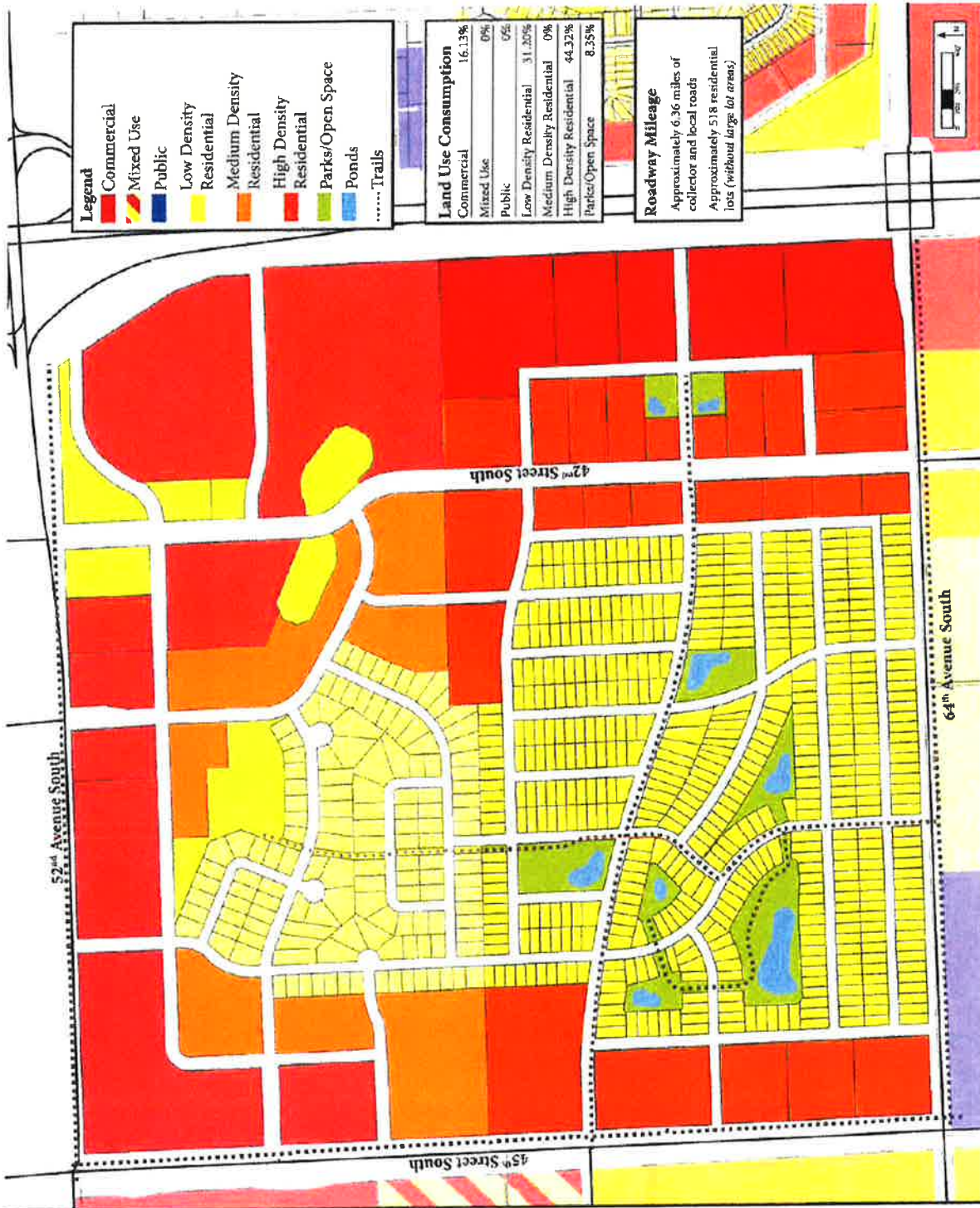

Figure 5.1
Fargo Preferred Future Land Use Plan Update
 Southwest Metro Transportation Plan • • • • FARGO-MOORHEAD METROPOLITAN COUNCIL OF GOVERNMENTS

**Section 3 Township 138 Range 49
Conceptual Master Plan**

- Critical Planning Elements**
 - Grade Separation Right of Way (ROW) Preservation
 - 64th Avenue Grade Separation
 - Preservation of Right of Way for functionally classified roadways
 - Minor Arterial
 - 42nd Street - 120 feet
 - 64th Avenue - 200 feet
 - Mid-Section Collector - 80 feet
 - Local Streets - 62 to 70 feet
 - Connectivity
 - Development of a minor collector system through the section
 - Multiple streets that provide ingress and egress to destinations within the section
 - Elimination of cul-de-sacs for ease of maintenance activities
 - Commercial Block Depth
 - Commercial depths range from 300 to 600 feet
 - Access Management
 - Functionally classified roadways follow access guidelines according to the Fargo Land Development Code
 - Residential Block Depth
 - Low Density Residential - 300 feet
 - Medium Density Residential - 100 feet
 - High Density Residential - 230 to 300 feet
 - Open Space/Storm Water Retention
 - 7-11% open space through development area.
 - Provide on-site retention as needed to meet floodplain development regulations.
 - Utilize existing low lying areas for development of ponds.
 - Land Use Transitions
 - Maintain transitions and buffering between higher and lower intensity land uses with the use of streets, medium intensity uses or landscape buffers.
 - Trail Network
 - Develop a trail network with connectivity within and outside of the section.



**Section 10 Township 138 Range
49 Conceptual Master Plan**

Critical Planning Elements

- **Grade Separation Right of Way (ROW) Preservation**
 - 64th Avenue Grade Separation
 - 76th Avenue Interchange
- **Preservation of Right of Way for functionally classified roadways**
 - **Principal Arterial**
 - 76th Avenue - 200 feet
 - **Minor Arterial**
 - 42nd Street - 120 feet
 - 64th Avenue - 200 feet
 - **Mid-Section Collector** - 80 feet
 - **Local Streets** - 62 to 70 feet
- **Connectivity**
 - Development of a minor collector system through the section
 - Multiple streets that provide ingress and egress to destinations within the section
 - Elimination of cul-de-sacs for ease of maintenance activities
- **Commercial Block Depth**
 - Commercial depths range from 300 to 600 feet
- **Access Management**
 - Functionally classified roadways follow access guidelines according to the Fargo Land Development Code
- **Residential Block Depth**
 - Low Density Residential - 300 feet
 - Medium Density Residential - 100 feet
 - High Density Residential - 236 to 300 feet
- **Open Space/Storm Water Retention**
 - 7-11% open space through development area.
 - Provide on-site retention as needed to meet floodplain development regulations.
 - Utilize existing low lying areas for development of ponds.
- **Land Use Transitions**
 - Maintain transitions and buffering between higher and lower intensity land uses with the use of streets, medium intensity uses or landscape buffers.
- **Trail Network**
 - Develop a trail network with connectivity within and outside of the section.

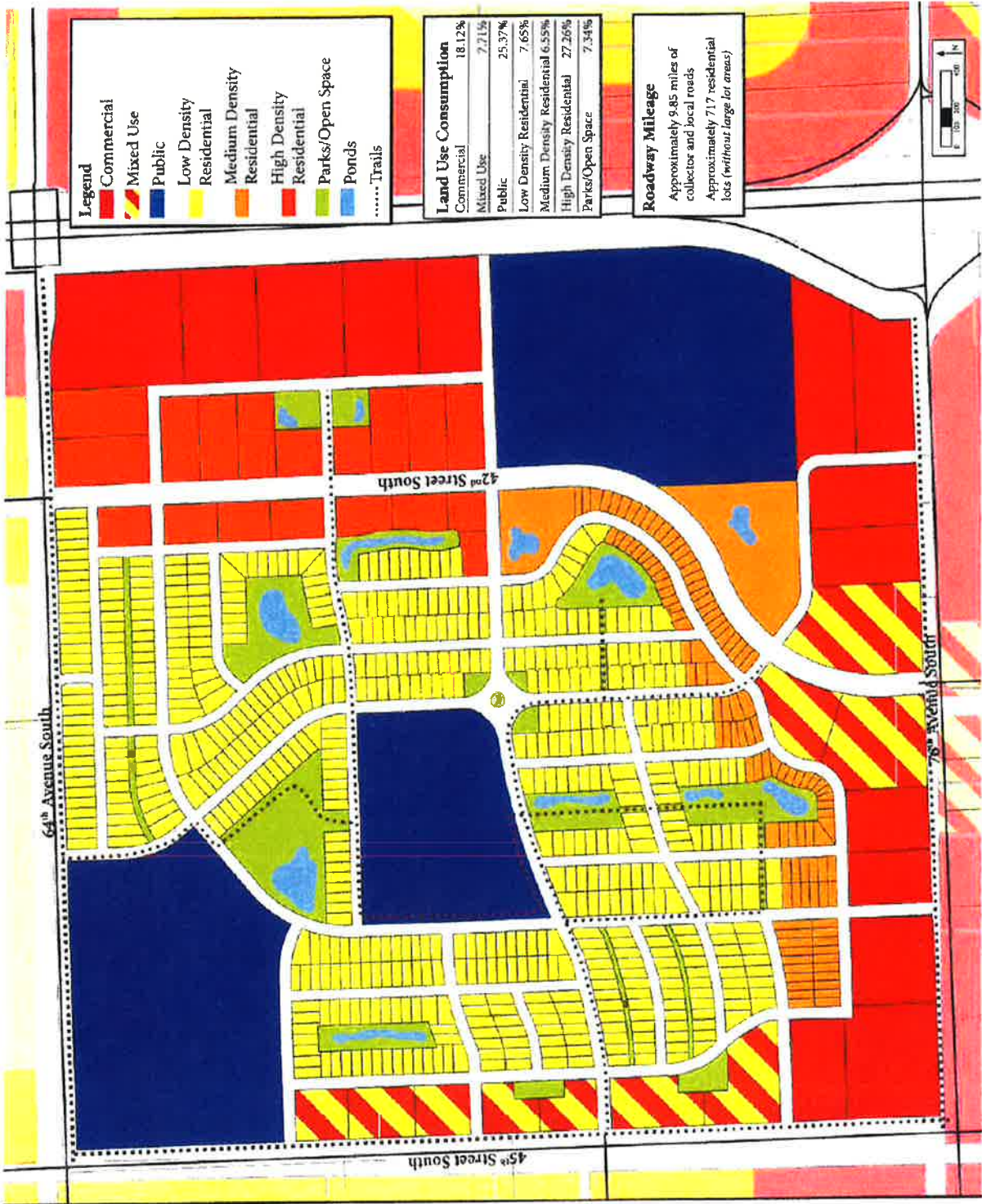

Build Alternatives



> 3 Lane

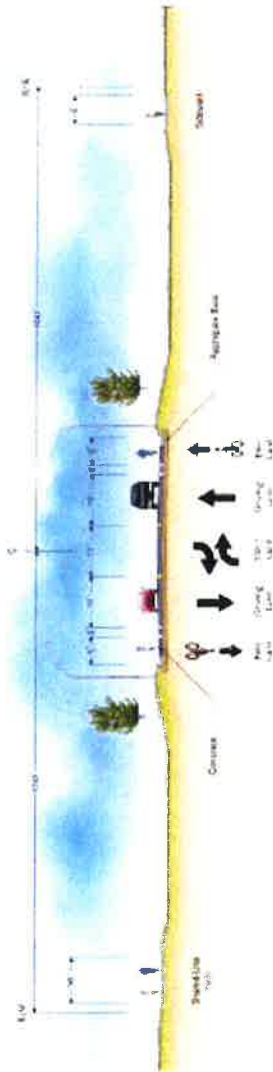

> 3 Lane with Bike Lanes



> 3 Lane with Cycle Track

3 Lane Section with Cycle Track

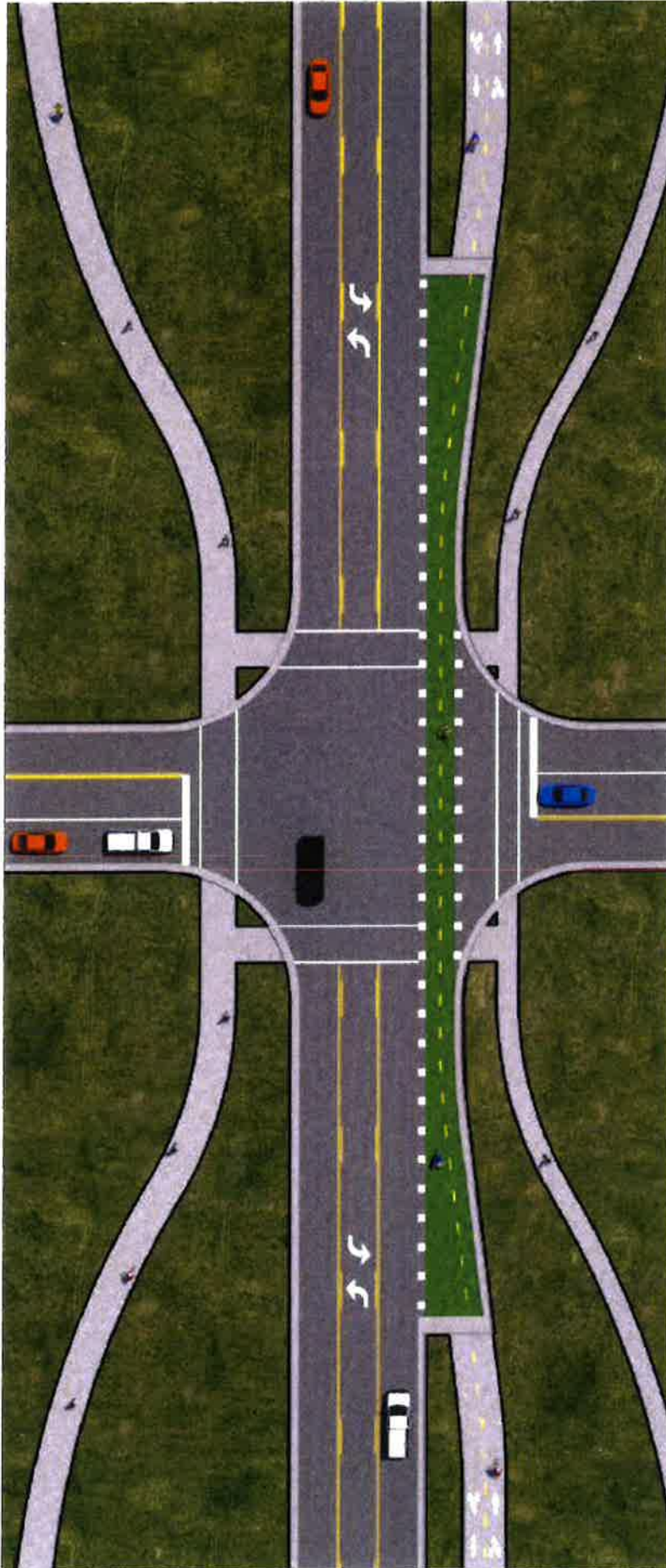

3 Lane Section

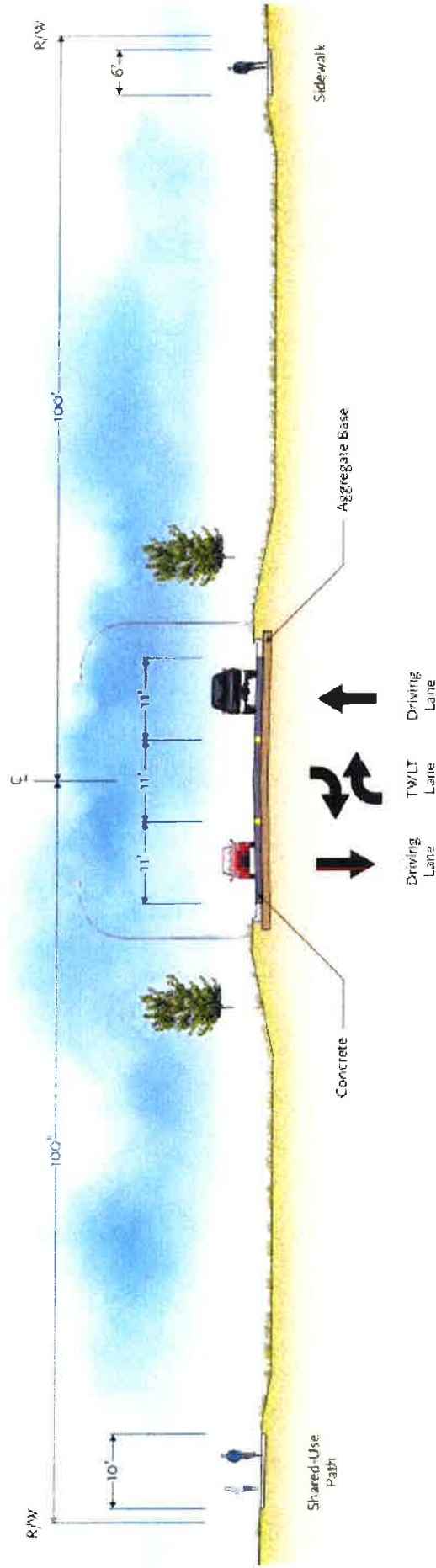

Estimated Construction Cost

25.5M – 27.2M

3 Lane Section with Bike Lanes

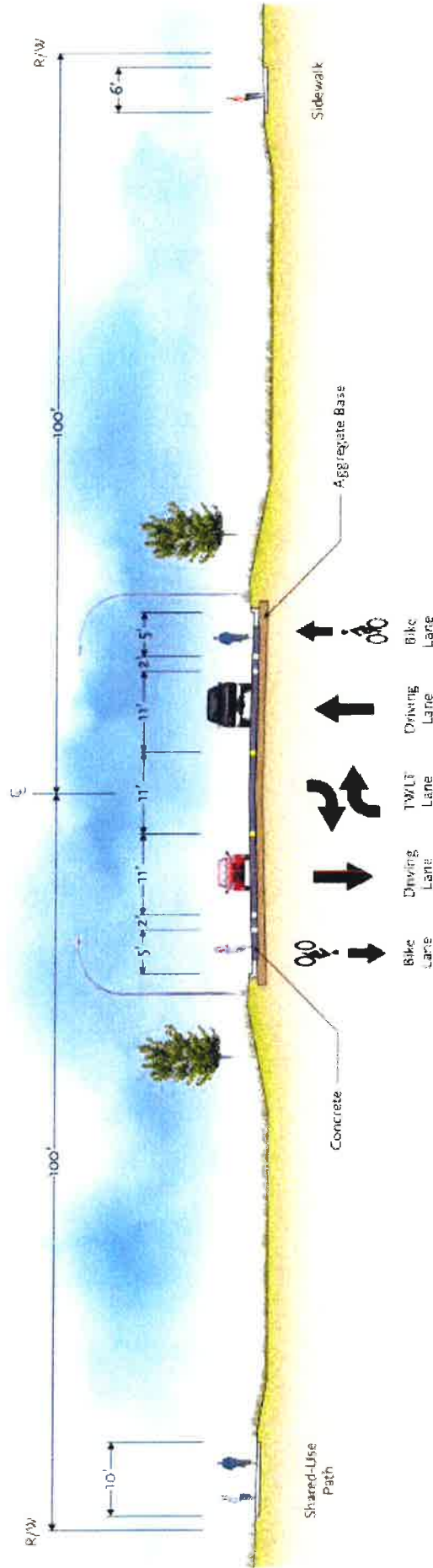

Estimated Construction Cost

27.5M – 29.4M

3 Lane Section with Cycle Track

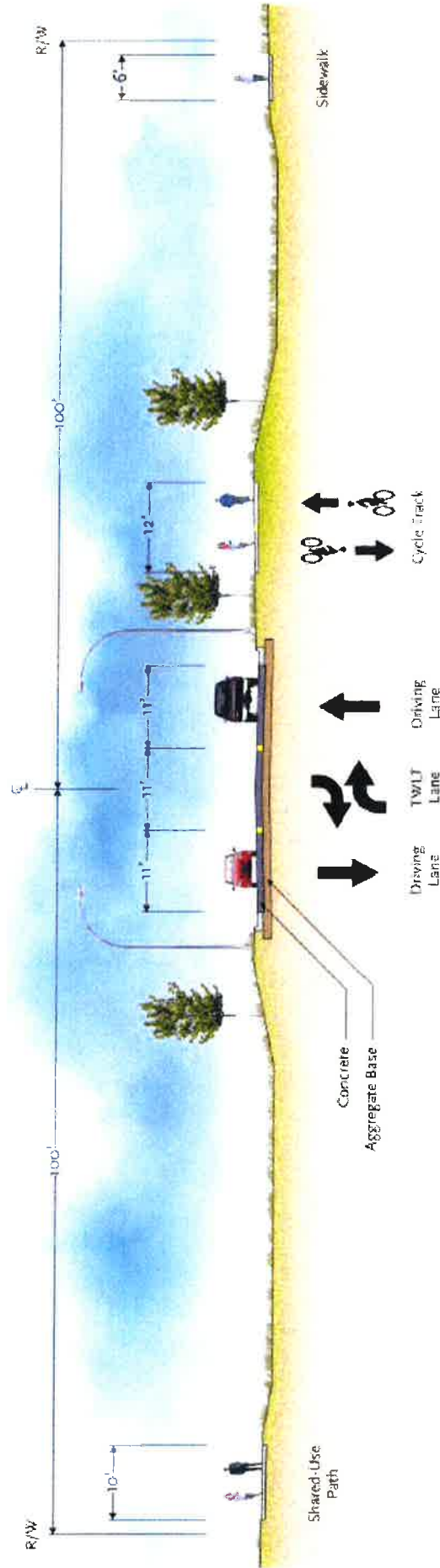

Estimated Construction Cost

27.1M – 29.5M

Funding

- \$10M Federal
- ~\$12M Special Assessments
- Balance City Funds

3-Lane roadway

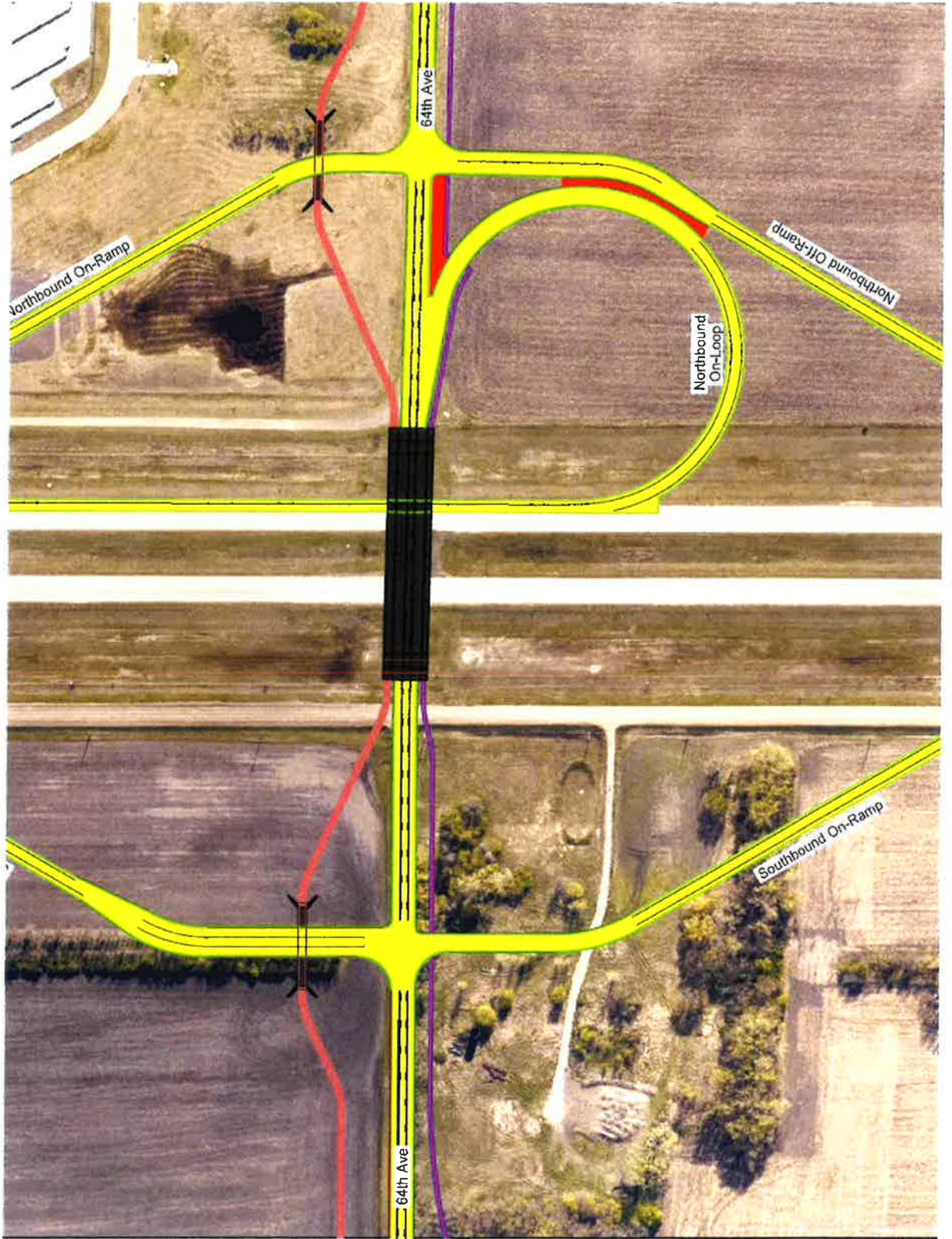

**Engineers Opinion of Probable Cost
 Fargo, North Dakota - 64th Ave Construction
 Interchange Cost Estimate (Additional Cost) (Earthen Embankment, 3 Lane Roadway, 2 Span Bridge)**

SPEC	CODE	ITEM DESCRIPTION	UNIT	Total	UNIT PRICE	TOTAL PRICE
103	0100	CONTRACT BOND	L SUM	1	\$ 110,000.00	\$ 110,000.00
202		REMOVALS	L SUM	1	\$ 61,100.00	\$ 61,100.00
203	0101	COMMON EXCAVATION-TYPE A	CY	6,100	\$ 6.00	\$ 36,600.00
203	0109	TOPSOIL	CY	33,800	\$ 6.00	\$ 202,800.00
203	0140	BORROW-EXCAVATION	CY	319,000	\$ 9.19	\$ 2,930,400.00
251		EROSION CONTROL	L SUM	1	\$ 212,600.00	\$ 212,600.00
302	0121	AGGREGATE BASE COURSE CL 5	CY	13,700	\$ 35.00	\$ 479,500.00
550	0310	10IN NON REINF CONCRETE PVMT CL AE-DOWELED	SY	33,000	\$ 65.00	\$ 2,145,000.00
606		PED UNDERPASS EAST	LSUM	1	\$ 170,000.00	\$ 170,000.00
606	0001	PED UNDERPASS WEST	LSUM	1	\$ 220,000.00	\$ 220,000.00
702	0100	MOBILIZATION	L SUM	1	\$ 1,100,000.00	\$ 1,100,000.00
714		CULVERTS	L SUM	1	\$ 172,500.00	\$ 172,500.00
748	0140	CURB & GUTTER-TYPE I	LF	4,800	\$ 24.00	\$ 115,200.00
750	0030	PIGMENTED IMPRINTED CONCRETE	SY	1,000	\$ 95.00	\$ 95,000.00
750	0115	SIDEWALK CONCRETE 4IN	SY	3,300	\$ 35.00	\$ 115,500.00
754		SIGNING	L SUM	1	\$ 578,200.00	\$ 578,200.00
762		PAVEMENT MARKING	L SUM	1	\$ 87,800.00	\$ 87,800.00
770		LIGHTING	L SUM	1	\$ 1,208,200.00	\$ 1,208,200.00
772		TRAFFIC SIGNALS	L SUM	1	\$ 550,000.00	\$ 550,000.00
920		GEOTECH AND SURCHARGE	L SUM	1	\$ 3,600,000.00	\$ 3,600,000.00
930		BRIDGE	L SUM	1	\$ 578,000.00	\$ 578,000.00
					Additional Interchange Subtotal	\$ 14,768,400.00
					Adtl Contingencies & Engineering (20%)	\$ 2,953,680.00
					Additional Interchange Costs	\$ 17,722,080.00

5-lane roadway west of 33rd Street

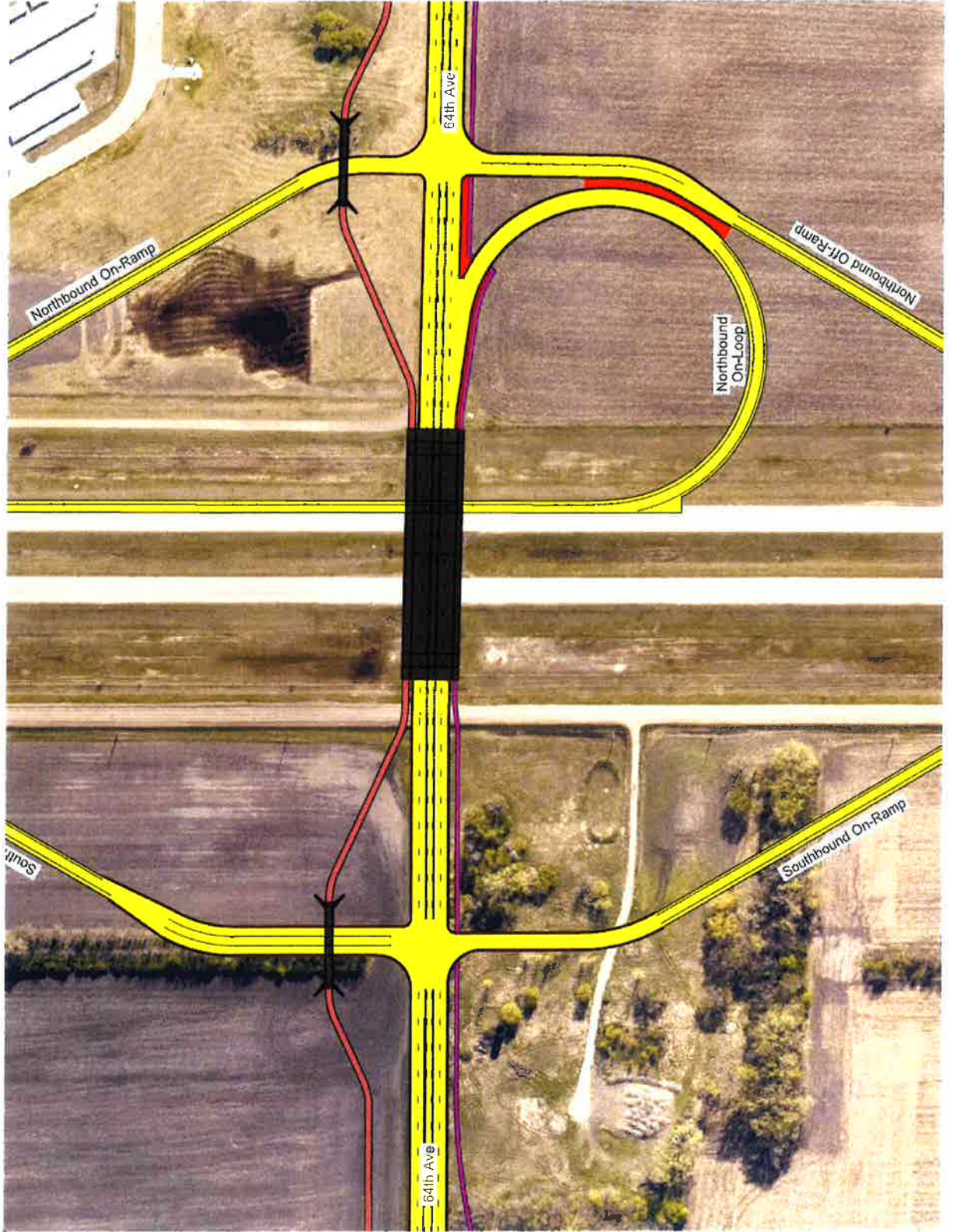

**Engineers Opinion of Probable Cost
 Fargo, North Dakota - 64th Ave Construction
 Interchange Cost Estimate (Additional Cost) (Earthen Embankment, 5 Lane Roadway, 2 Span Bridge)**

SPEC	CODE	ITEM DESCRIPTION	UNIT	Total	UNIT PRICE	TOTAL PRICE
103	0100	CONTRACT BOND	L SUM	1	\$ 130,000.00	\$ 130,000.00
202		REMOVALS	L SUM	1	\$ 61,100.00	\$ 61,100.00
203	0101	COMMON EXCAVATION-TYPE A	CY	6,600	\$ 6.00	\$ 39,600.00
203	0109	TOPSOIL	CY	33,800	\$ 6.00	\$ 202,800.00
203	0140	BORROW-EXCAVATION	CY	403,400	\$ 9.01	\$ 3,636,000.00
251		EROSION CONTROL	L SUM	1	\$ 212,600.00	\$ 212,600.00
302	0121	AGGREGATE BASE COURSE CL 5	CY	19,400	\$ 35.00	\$ 679,000.00
550	0310	10IN NON REINF CONCRETE PYMT CL AE-DOWELED	SY	50,400	\$ 65.00	\$ 3,276,000.00
606		PED UNDERPASS EAST	L SUM	1	\$ 170,000.00	\$ 170,000.00
606	0001	PED UNDERPASS WEST	L SUM	1	\$ 220,000.00	\$ 220,000.00
702	0100	MOBILIZATION	L SUM	1	\$ 1,300,000.00	\$ 1,300,000.00
714		CULVERTS	L SUM	1	\$ 172,500.00	\$ 172,500.00
748	0140	CURB & GUTTER-TYPE I	LF	4,800	\$ 24.00	\$ 115,200.00
750	0030	PIGMENTED IMPRINTED CONCRETE	SY	1,000	\$ 95.00	\$ 95,000.00
750	0115	SIDEWALK CONCRETE 4IN	SY	3,300	\$ 35.00	\$ 115,500.00
754		SIGNING	L SUM	1	\$ 578,200.00	\$ 578,200.00
762		PAVEMENT MARKING	L SUM	1	\$ 101,000.00	\$ 101,000.00
770		LIGHTING	L SUM	1	\$ 1,208,200.00	\$ 1,208,200.00
772		TRAFFIC SIGNALS	L SUM	1	\$ 550,000.00	\$ 550,000.00
920		GEOTECH AND SURCHARGE	L SUM	1	\$ 3,600,000.00	\$ 3,600,000.00
930		BRIDGE	L SUM	1	\$ 1,616,000.00	\$ 1,616,000.00
					Additional Interchange Subtotal	\$ 18,078,700.00
					Addl Contingencies & Engineering (20%)	\$ 3,615,740.00
					Additional Interchange Costs	\$ 21,694,440.00

27

June 12, 2019

Honorable Board of City
Commissioners
City of Fargo
Fargo, ND

Re: Improvement District No. SL-19-B1

Dear Commissioners:

Bids were opened at 11:30 AM on Wednesday, June 12, 2019, for Street Lighting & Incidentals, Improvement District No. SL-19-B1, located at 19th Avenue North to 29th Avenue North and between Broadway North to Evergreen Road North.

The bids were as follows:

Strata Corporation	\$ 747,390.75
Sun Electric	\$ 785,540.75
Moorhead Electric	\$ 850,995.55
Scott's Electric, Inc.	\$ 881,248.15
Engineer's Estimate	\$ 909,006.15

The special assessment escrow is not required.

This office recommends award of the contract to Strata Corporation in the amount of \$747,390.75 as the lowest and best bid. No protests have been received.

Sincerely,



Tom Knakmuhs
Assistant City Engineer

TAK/klb

ENGINEER'S STATEMENT OF ESTIMATED COST

IMPROVEMENT DISTRICT # SL-19-B1

Street Lighting & Incidentals

19th Ave N to 29th Ave N and between Broadway N and Evergreen Road N.

WHEREAS, bids have been opened and filed for the above described Improvement District for City of Fargo, North Dakota; and
 WHEREAS, an estimate of the cost of work is required by the engineer for the City of Fargo, North Dakota;

NOW THEREFORE Tom Knakmuhs, do hereby certify as follows:

That I am the Assistant City Engineer for the City of Fargo, North Dakota;

That the following is detailed statement of the estimated cost of the job described as:

Street Lighting & Incidentals Improvement District # SL-19-B1 of the City of Fargo, North Dakota.

Line Description	Unit	Quantity	Unit Price (\$)	Amount (\$)
Miscellaneous/Street Lighting				
1 Remove Street Light	EA	5.00	250.00	1,250.00
2 F&I Feed Point	EA	3.00	8,500.00	25,500.00
3 Remove Feed Point	EA	3.00	100.00	300.00
4 F&I Base 5' Deep Reinf Conc	EA	181.00	600.00	108,600.00
5 Remove Base	EA	5.00	800.00	4,000.00
6 F&I Conductor #6 USE Cu	LF	86,499.00	1.25	108,123.75
7 F&I Innerduct 1.5" Dia	LF	29,231.00	7.00	204,617.00
8 F&I Luminaire Type A	EA	181.00	200.00	36,200.00
9 F&I Pull Box	EA	17.00	800.00	13,600.00
10 Remove Pull Box	EA	1.00	200.00	200.00
11 F&I Light Standard Type A	EA	181.00	1,250.00	226,250.00
12 Rem & Repl Sidewalk 4" Thick Reinf Conc	SY	100.00	105.00	10,500.00
13 Rem & Repl Sidewalk 6" Thick Reinf Conc	SY	50.00	125.00	6,250.00
14 Traffic Control - Minor	LS	1.00	2,000.00	2,000.00
			Miscellaneous/Street Lighting Total	747,390.75
			Total Construction in \$	747,390.75
			Engineering	11.00 %
			Legal & Misc	3.00 %
			Contingencies	10.00 %
			Administration	6.00 %
			Interest	4.00 %
			Total Estimated Costs	1,001,503.60
			Special Assessments	1,001,503.61
			Unfunded Costs	-0.01

IN WITNESS THEREOF, I have hereunto set my hand and seal

Date: 06/12/2019



Tom Knakmuhs

Assistant City Engineer

